

Technical University of Denmark



ACCUWIND - Accurate wind speed measurements in wind energy - Summary report

Friis Pedersen, Troels; Dahlberg, J.-Å.; Cuerva, A.; Mouzakis, F.; Busche, P.; Eecen, P.; Sanz-Andres, A.; Franchini, S.; Markkilde Petersen, Søren

Publication date:
2006

Document Version
Publisher's PDF, also known as Version of record

[Link back to DTU Orbit](#)

Citation (APA):
Friis Pedersen, T., Dahlberg, J.-Å., Cuerva, A., Mouzakis, F., Busche, P., Eecen, P., ... Markkilde Petersen, S. (2006). ACCUWIND - Accurate wind speed measurements in wind energy - Summary report. (Denmark. Forskningscenter Risoe. Risoe-R; No. 1563(EN)).

DTU Library

Technical Information Center of Denmark

General rights

Copyright and moral rights for the publications made accessible in the public portal are retained by the authors and/or other copyright owners and it is a condition of accessing publications that users recognise and abide by the legal requirements associated with these rights.

- Users may download and print one copy of any publication from the public portal for the purpose of private study or research.
- You may not further distribute the material or use it for any profit-making activity or commercial gain
- You may freely distribute the URL identifying the publication in the public portal

If you believe that this document breaches copyright please contact us providing details, and we will remove access to the work immediately and investigate your claim.

ACCUWIND - Accurate Wind Speed Measurements in Wind Energy

Summary Report

Troels Friis Pedersen
Jan-Åke Dahlberg
Alvaro Cuerva
Fragiskos Mouzakis
Peter Busche
Peter Eecen
Angel Sanz-Andres
S Franchini
Søren Markkilde Petersen



Author: Troels Friis Pedersen (RISØ), Jan-Åke Dahlberg (FOI), Alvaro Cuerva (UPM), Fragiskos Mouzakis (CRES), Peter Busche (DEWI), Peter Eecen (ECN), Angel Sanz-Andres (UPM), S Franchini (UPM), Søren Markkilde Petersen (RISØ)
Title: ACCUWIND – Accurate Wind Speed Measurements in Wind Energy – Summary Report
Department: Wind Energy Department

Abstract (max. 2000 char.):

The cup anemometer is at present the standard instrument used for mean wind speed measurement in wind energy. It is being applied in high numbers around the world for wind energy assessments. It is also applied exclusively for accredited power performance measurements for certification and verification purposes, and for purposes of optimisation in research and development. The revised IEC standard on power performance measurements has now included requirements for classification of cup anemometers. The basis for setting up such requirements of cup anemometers is two EU projects SITEPARIDEN and CLASSCUP from which the proposed classification method for cup anemometers was developed for the IEC standard. While cup anemometers at present are the standard anemometer being used for average wind speed measurements, sonic anemometers have been developed significantly over the last years, and prices have come down. The application of sonic anemometers may increase in wind energy if they prove to have comparable or better operational characteristics compared to cup anemometers, and if similar requirements to sonic anemometers are established as for cup anemometers. Sonic anemometers have historically been used by meteorologists for turbulence measurements, but have also found a role on wind turbine nacelles for wind speed and yaw control purposes. The report on cup and sonic anemometry deals with establishment of robustness in assessment and classification by focus on methods and procedures for analysis of characteristics of cup and sonic anemometers. The methods and procedures provide a platform, hopefully for use in meeting the requirements of the IEC standard on power performance measurements, as well as for development of improved instruments.

Risø-R-1563(EN)
July 2006

ISSN 0106-2840
ISBN 87-550-3526-4

Contract no.:
NNE5-2001-00831

Group's own reg. no.:

Sponsorship:
European Commission

Cover :

Pages: 25
Tables: 19
References:13

Risø National Laboratory
Information Service Department
P.O.Box 49
DK-4000 Roskilde
Denmark
Telephone +45 46774004
bibl@risoe.dk
Fax +45 46774013
www.risoe.dk

Contents

Preface 4

Introduction 5

1 Objectives 5

2 Project Reports Summary 7

3 Project Results Summary 7

3.1 Task 1 Cup anemometry 7

3.2 Task 1 Wind Tunnel Blockage 12

3.3 Task 2 Sonic Anemometry 14

3.4 Task 3 Definition of Wind Speed 18

4 General Conclusions 21

5 References 23

Preface

This report presents summary results of the European research project “ACCUWIND - Accurate Wind Speed Measurements in Wind Energy”. The project focuses on improvement of evaluation and classification methods of cup and sonic anemometry. The project partners of the ACCUWIND project were:

- Risø National Laboratory, RISØ, Denmark, Coordinator*
- Deutsches Windenergie Institut GmbH, DEWI, Germany*
- Swedish Defence Research Agency, FOI, Sweden*
- Centre for Renewable Energy Sources, CRES, Greece*
- Energy Research Centre of the Netherlands, ECN, the Netherlands*
- Universidad Politecnica de Madrid, UPM, Spain*

The work was made under contract with the European Commission, project number NNE5-2001-00831.

1 Introduction

The cup anemometer is at present the standard instrument used for mean wind speed measurement in wind energy. It is being applied in high numbers around the world for wind energy assessments. It is also applied exclusively for accredited power performance measurements for certification and verification purposes, and for purposes of optimisation in research and development. The revised IEC standard on power performance measurements [7] has now included requirements for classification of cup anemometers. The basis for setting up such requirements of cup anemometers is two EU projects. The SITEPARIDEN project [1,2,3,4] showed measured differences between various types of cup anemometers up to 4%, which is significant when the limits of power performance acceptance is 95% of guaranteed. The CLASSCUP project [5,6] proved that these differences were due to angular response, dynamic effects and bearing friction characteristics, which differs on various types of cup anemometers, and the project also proposed a classification method for cup anemometers [8], which was the basis for the classification system now implemented in the IEC standard [7].

While cup anemometers at present are the standard anemometer being used for average wind speed measurements, sonic anemometers have been developed significantly over the last years, and prices have come down. The application of sonic anemometers may increase in wind energy if they prove to have comparable or better operational characteristics compared to cup anemometers, and if similar requirements to sonic anemometers are established as for cup anemometers. Sonic anemometers have historically been used by meteorologists for turbulence measurements, but have also found a role on wind turbine nacelles for wind speed and yaw control purposes.

This report on assessment methods of cup and sonic anemometry deals with establishment of robustness in assessment and classification by focus on methods and procedures for analysis of characteristics of these instruments. The methods and procedures provide a platform, that a user hopefully could apply to meet the requirements of the IEC standard on power performance measurements [7], as well as for development of improved instruments.

2 Objectives

The objective of the project was to provide basis for accurate wind speed measurements using cup and sonic anemometers. A part of the objective was to improve tools and methods to assess the accuracy of cup and sonic anemometers in wind energy measurements by development and implementation of procedures for calibration, field comparison, benchmark tests and classification. Another part of the objective was to define measured wind speed for power performance measurements in a consistent way, so that uncertainties of wind speed sensors can be reduced.

A part of the objective was to improve basis for accuracy of cup anemometers. The influence of longitudinal and vertical inflow turbulence on cup anemometers should be detected and quantified by wind tunnel and field tests. Blockage effects in open and closed wind tunnels should be detected and quantified, and improved correction procedures be implemented for anemometer calibrations. Robust procedures for classification of cup

anemometers should be made and a range of sensors benchmark tested and put into the classification scheme.

Another part of the objective is to improve accuracy of sonic anemometers. Influence parameters on sonic anemometers with respect to calibration and classification should be detected and quantified. Wind tunnel calibration procedures and field comparison methods for sonic anemometers (average wind speeds) should be developed and implemented. A procedure for classification of sonic anemometers (average wind speeds) should be proposed and a range of sensors benchmark tested and put into the classification scheme.

Another part of the objective is to define measured wind speed in a consistent way. The response of the turbulence and inclined flow on the performance of a wind turbine should be analysed to determine the most appropriate measured wind speed definition to use in power performance measurements.

Specifically, the technical and scientific objectives of the project were:

Task 1) To improve tools and methods to assess the accuracy of cup anemometers in wind energy measurements:

- To develop and implement robust procedures for measurement of torque characteristics of cup anemometers
- To develop advanced wind tunnel calibration procedures to measure response of longitudinal and vertical dynamic inflow
- To develop and implement more accurate blockage correction factors in cup anemometer calibrations to be adopted in MEASNET calibration procedures
- To demonstrate that simulations of cup anemometers on the basis of wind tunnel and laboratory tests can explain free field measurements
- To demonstrate robustness of classification demands of cup anemometers in order to accept/reject instruments (to be adopted by the MEASNET organisation)
- To classify a number of commercial cup anemometers with robust procedures
- To investigate and quantify the influence of rain and deflections and vibrations of booms on tall masts

Task 2) To assess the accuracy of sonic anemometers in wind energy measurements

- To quantify influence parameters on sonic anemometers over a range of applications and range of climatic conditions
- To quantify directivity of sonic anemometers by wind tunnel measurements and quantify their mutual deviations in field comparisons
- To propose calibration procedures for sonic anemometers
- To propose classification procedures for sonic anemometers
- To compare sonic anemometers with cup anemometers in average wind speed measurements

Task 3) To define measured wind speed for power performance measurements

- To quantify the sensitivity of wind turbines to turbulence components and flow inclination angle
- To analyse different types of definitions and to compare their outcome
- To arrive at an agreement of one definition of measured wind speed to be used for power performance measurements

3 Project Reports Summary

The project has been reported in a number of public reports. Task 1 on cup anemometry was basically reported in three public reports [9,10,11]. Task 1 on assessment and classification methods for cup anemometers in [9]. Task 1 on classification of five commercial cup anemometers in [10]. Task 1 on wind tunnel blockage effects in cup anemometer calibration in [11]. Task 2 on assessment and classification methods for sonic anemometers in [12]. Task 3 on definition of measured wind speed in [13]. Each report should be consulted for detailed information on the subject. The project reports can be requested from the lead authors. A seminar for manufacturers of cup and sonic anemometers was held at CRES in Greece 24 February 2006, where the project results were presented.

4 Project Results Summary

4.1 Task 1 Cup anemometry

The reports [9,10] covers the work on assessment of cup anemometry. The report [9] addresses cup anemometer assessment and classification methods, based on the requirements in the IEC61400-12-1 standard on power performance measurements [7]. An introduction of the ideas behind the classification procedure is outlined, and the requirements for external operational conditions are examined in detail. A chapter presents a range of different testing methods that all support robust assessment of the cup anemometers. Some basic testing methods are used to provide data to be fitted to cup anemometer models. The models, that are used are the IFTC model (Inclined Flow Torque Coefficient model) and the TRTC model (the Tilt Response Torque Coefficient model), and other testing methods are used for verification of the tuned models to “check” that they are able to simulate operational conditions realistically. The basic testing methods are: normal calibration, angular response measurements, static torque coefficient measurements, and measurement of friction.

An additional new dynamic torque coefficient test method was developed. It involves exposure of the anemometers to wind gusts in a wind tunnel together with accurate measurements of the instantaneous wind speed and of the rotational speed of the cup-anemometer. The method requires no attachment of a rod to the rotor as for the static torque coefficient measurement, but requires on the other hand a high angular sensitivity of the tooth wheel of the cup anemometer, i.e. many pulses per revolution, and also that the pulses are unequal in length. Each pulse length is measured with a high sample rate to detect the tooth wheel signature. Figure 4-1 shows a tooth wheel signature for a cup anemometer with 44 pulses per revolution in still air (no wind). The method uses the tooth wheel signature for an average correction of the rotational speed. In a constant wind a regular angular speed pattern is revealed due to the pulsations from the cups, see Figure 4-2.

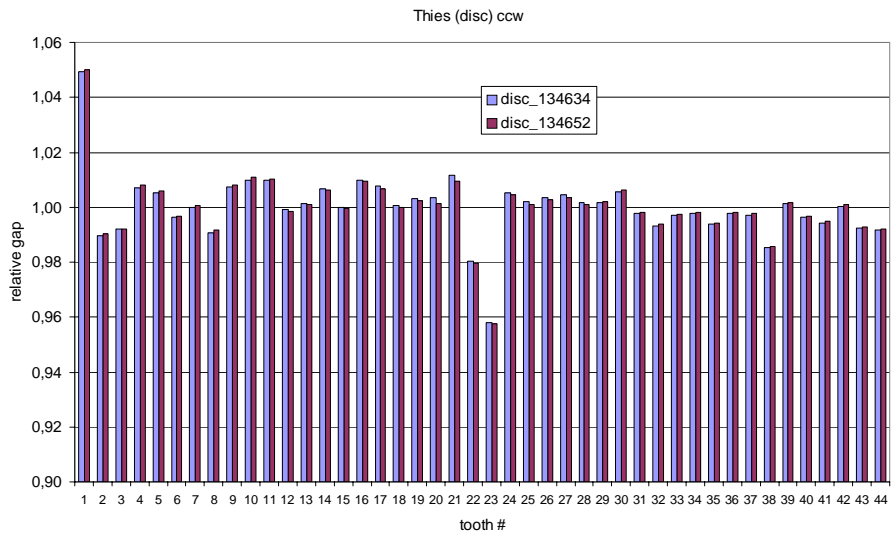

Figure 4-1 Absolute measure of the tooth wheel signature by means of disc rotation in still air. Two 10-second measurements with 100 kHz clock pulse frequency for the timing of the pulses. Difference between the smallest and widest gap is about 10%.

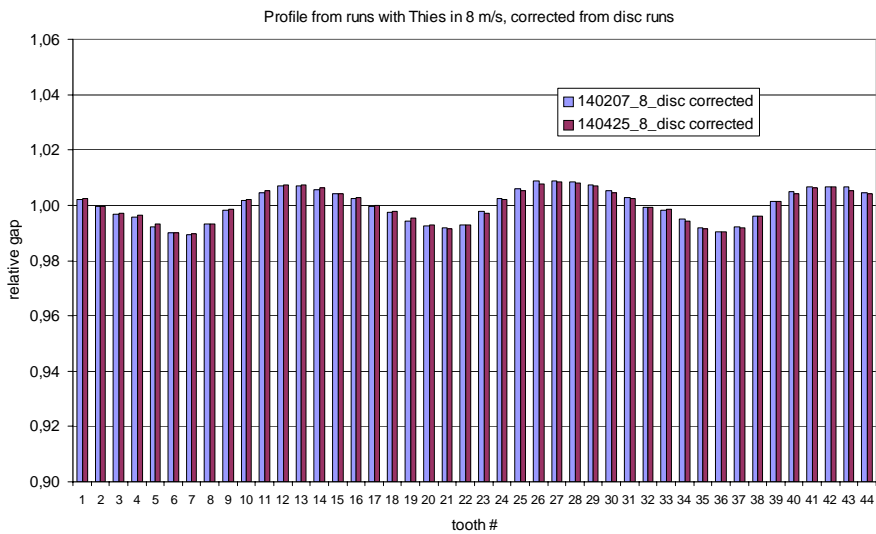

Figure 4-2 Determination of detailed rotational speed by use of the tooth wheel signature. The three per rev variation due to each cup appears very clearly.

This new method was compared to the more traditional static torque coefficient measurement procedure, and very good agreement was found between the two methods. The new dynamic torque coefficient test method has the advantage that torque can be measured under inclined flow by tilting the cup anemometer in the wind tunnel. This has given rise to the new cup anemometer model, the IFTC model, which bases the aerodynamic torque on dynamic torque coefficient measurements for all tilt angles, and do not include traditional angular response measurements in the model.

The robustness of the IFTC model was verified by comparing simulations with ordinary gust runs in the wind tunnel, and very good agreement was found. Figure 4-3 shows a comparison of torque measurements on a Risø P2546 cup anemometer with the two different methods.

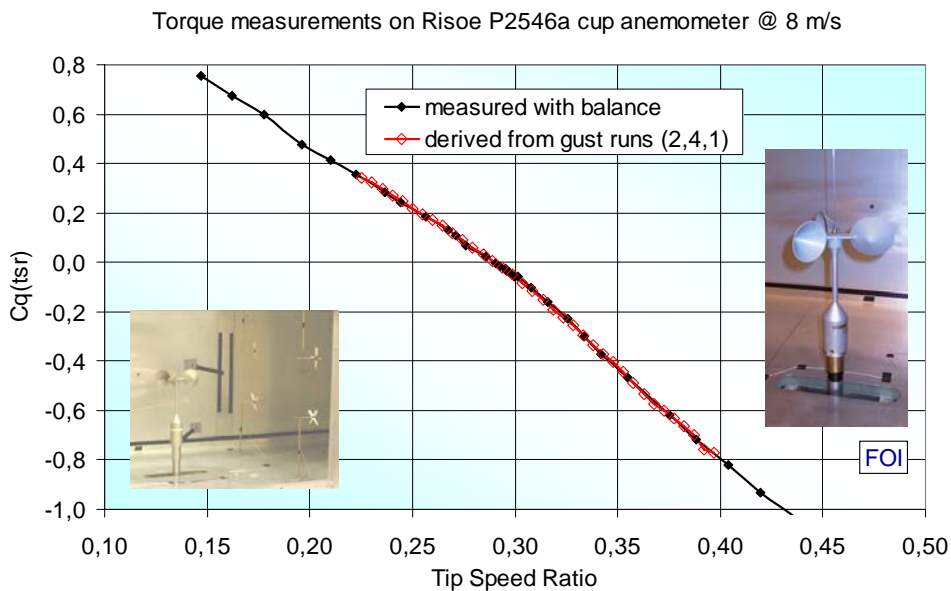

Figure 4-3 The graph shows a comparison of C_q in vertical position for the Risø P2546 cup anemometer measured with the static and the dynamic torque measurement methods. Speed ratio from dynamic measurement has been offset by -0.006 and C_q scaled up by 7% (rotation around $C_q=0$)

Simulations were also compared with step response measurements with good result. The inclined flow torque coefficient curves of the IFTC model was used to compare static angular response measurements. This comparison showed no deviations between the data. This verifies that angular response data obtained by static measurements are similar to data obtained by dynamic measurements. Figure 4-4 shows a typical comparison for a Vector cup anemometer.

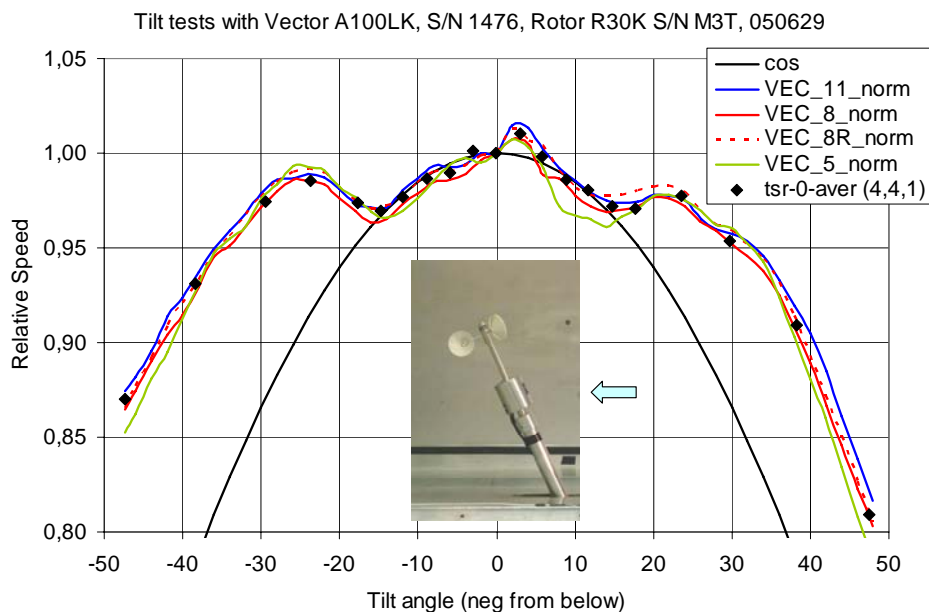

Figure 4-4 Comparison of the results from the tilt tests and the torque interception points (black diamond symbols) from the ramp-gust tests for the Vector A 100LK cup anemometer.

The application of the test procedures has been examined in classification. The robustness of the classification process depends on robustness of the calibration procedures, robustness of the models, and general robustness of application. The calibration of angular response was compared with measurements of FOI and DEWI. Significant differences

were found in these measured data. The causes for the deviations in the calibrations have not been examined in detail. FOI is using a closed test section and the anemometer is moved back and forth in the test section to obtain different tilted positions. The wind tunnel used by DEWI is an open test section and the anemometer rotor centre is kept fixed for all tilted positions. The differences influence significantly on the results of classification, and are the main reason for spreading of classification index data.

The robustness of the models was demonstrated with the IFTC model by verification of simulations to a step response and to response from gust runs. An example of verification of the TRTC model was made for a normal calibration.

The robustness of classification was exemplified by a comparison of four classifications made with both the TRTC and IFTC models on one type of cup anemometer. The results showed variations of Class A index of 1.3-1.9 and of Class B index of 5.0-8.0. The main reason for these deviations was found in angular response differences measured at DEWI and FOI.

Another classification example of five simulations on another cup anemometer type was made with inclusion and exclusion of friction. The result showed variations of Class A index of 0.6-2.4 and of Class B index of 7.5-8.3. The large variations in Class A index was found to be due to measured friction variations at 40°C. Reduction of the temperature variation to 30°C reduced the Class A index from 2.4 to 1.1.

The two cup anemometer models were used to make classification of five different commercial cup anemometers [10].

Table 4-1 to Table 4-5 summarize the classification indices by the use of the two cup anemometer models IFTC and TRTC.

Table 4-1 Classification of five cup anemometers according to IEC51400-12-1 using the IFTC model (without influence of friction)

Cup anemometer	Classification IEC61400-12-1			
	Model: Inclined-Flow-Torque-Coefficient (IFTC)		Vector	
	Horizontal wsp definition		wsp definition	
	Class A	Class B	Class A	Class B
NRG max 40	0.6	7.5	0.5	2.6
Risø P2546	1.3	5.0	1.7	9.2
Thies FC	2.0	3.6	2.1	5.1
Vaisala WAA151	2.4	11.9	2.0	6.6
Vector L100	1.3	4.0	1.1	3.6

Table 4-2 Classification of five cup anemometers according to IEC51400-12-1 using the TRTC model with FOI tilt data and with influence of friction

Classification IEC61400-12-1				
Model: TRTC +FOI tilt response +with friction				
Cup anemometer	Horizontal		Vector	
	wsp definition		wsp definition	
	Class A	Class B	Class A	Class B
NRG max 40	2.4	8.3	2.7	3.0
Risø P2546	1.4	5.1	1.7	9.2
Thies FC	1.8	3.8	1.6	4.4
Vaisala WAA151	2.2	11.9	1.7	6.1
Vector L100	1.8	4.5	1.6	4.0

Table 4-3 Classification of five cup anemometers according to IEC51400-12-1 using the TRTC model with FOI tilt data and without influence of friction

Classification IEC61400-12-1				
Model: TRTC +FOI tilt response +without friction				
Cup anemometer	Horizontal		Vector	
	wsp definition		wsp definition	
	Class A	Class B	Class A	Class B
NRG max 40	1.0	8.3	0.8	2.2
Risø P2546	1.4	5.1	1.7	9.2
Thies FC	1.8	3.8	1.6	4.4
Vaisala WAA151	2.0	11.8	1.5	5.9
Vector L100	1.7	4.4	1.5	3.4

Table 4-4 Classification of five cup anemometers according to IEC51400-12-1 using the TRTC model with DEWI tilt data and with influence of friction

Classification IEC61400-12-1				
Model: TRTC +DEWI tilt response +with friction				
Cup anemometer	Horizontal		Vector	
	wsp definition		wsp definition	
	Class A	Class B	Class A	Class B
NRG max 40	2.4	7.7	2.8	4.8
Risø P2546	1.9	8.0	2.4	12.0
Thies FC	1.5	2.9	1.9	6.3
Vaisala WAA151	1.7	11.1	1.2	5.5
Vector L100	1.8	4.5	1.7	4.0

Table 4-5 Classification of five cup anemometers according to IEC51400-12-1 using the TRTC model with DEWI tilt data and without influence of friction

Classification IEC61400-12-1				
Model: TRTC +DEWI tilt response +without friction				
	Horizontal		Vector	
	wsp definition		wsp definition	
Cup anemometer	Class A	Class B	Class A	Class B
NRG max 40	1.9	7.7	2.1	4.4
Risø P2546	1.9	7.9	2.4	12.0
Thies FC	1.5	2.9	1.9	6.3
Vaisala WAA151	1.6	11.0	1.1	5.4
Vector L100	1.7	4.4	1.6	3.4

In summary, the classifications with the different models and the use of different test data results in some variation as shown in Table 4-6. The results according to the horizontal wind speed definition were:

Table 4-6 Classification ranges of five cup anemometers according to IEC51400-12-1 using the IFTC and TRTC models with various input data

Classification IEC61400-12-1		
All simulations		
	Horizontal	
	wsp definition	
Cup anemometer	Class A	Class B
NRG max 40	0.6 to 2.4	7.5 to 8.3
Risø P2546	1.3 to 1.9	5.0 to 8.0
Thies FC	1.5 to 1.8	2.9 to 3.8
Vaisala WAA151	1.6 to 2.4	11.0 to 11.9
Vector L100	1.3 to 1.8	4.0 to 4.5

The classifications of the five cup anemometers show quite some variation. The variations are explained by the exemplifications made for assessment of robustness. The most important factors are due to variations in tilt characteristics from different wind tunnels and inclusion or exclusion of friction. With respect to these variations there do not exist any standards or recommendations on how to perform these types of tests. The results are based on single examples of the type of cup anemometer. The IEC61400-12-1 standard requires at least two examples of a type of cup anemometer to be tested.

4.2 Task 1 Wind Tunnel Blockage

An investigation of wind tunnel blockage effects on cup anemometer calibrations was carried out and reported in [11]. The objective was to quantify blockage effects in wind tunnels and if possible to verify or improve correction methods when calibrating cup anemometers.

A slender anemometer body in combination with three rotors of different sizes was calibrated in five different wind tunnels. The smallest rotor was so small that blockage effects were negligible in the tunnels used and the large rotor so large that blockage effects were significant. Four wind tunnels were of the closed-test-section type and one wind tunnel of the open jet type. One of the closed tunnels had a significantly larger test section than the others and was used as a reference.

From each calibration of the three rotors the pulse frequency at 8 m/s was determined. The frequencies were normalised with the frequency for the smallest cup anemometer. The normalised frequencies were also normalised with the three frequencies from the largest wind tunnel in order to relate the frequencies to the “true” answer. These normalised figures were compared between the four tunnels, see Figure 4-5.

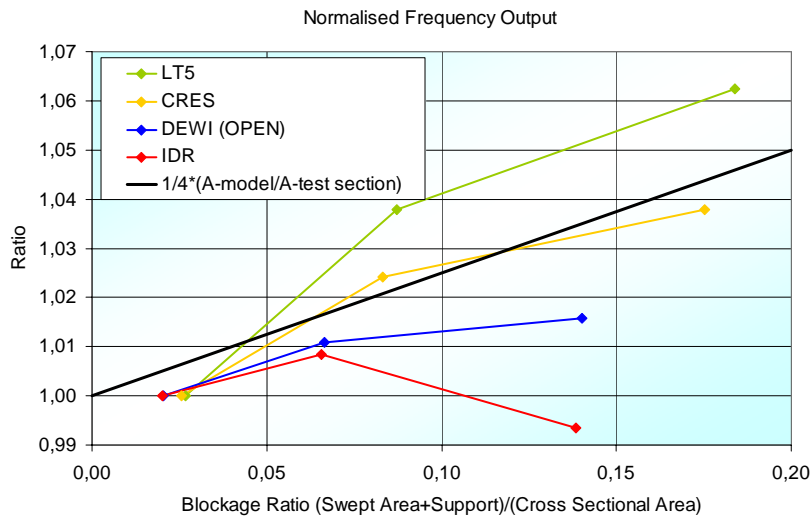

Figure 4-5 A graphical representation of the comparison of results from the four wind tunnels. The black line represents a theoretical recommended formula.

The results were not as expected. The blockage effects in the three closed test sections were expected to be of similar magnitude and follow a common trend. The blockage effects in the open test section were expected to be lower in magnitude and of opposite sign.

The unexpected results could be explained by the test conditions. An important pre-requisite for a successful outcome of a test was that the flow influence from the presence of the test object should not influence the measurement of the reference wind speed. However due to budgetary limitations in the project it was not possible to use other set-ups than the standard set-up normally used. Significant influences, from the test object on the measurement of the tunnel reference wind speed, could therefore not be excluded.

Consequently, no general conclusions about blockage could be drawn. Provided that the frequency values from each tunnel are reliable, individual correction recommendations for each tunnel could be given.

The method is straight forward and easy to use. In spite of the fact that no general conclusions about blockage effects could be drawn, it can be assumed that the method works well provided that more efforts are put on the localization of the position to measure the undisturbed wind tunnel wind speed.

4.3 Task 2 Sonic Anemometry

The work on sonic anemometry is reported in [12]. A brief review of the state-of-the-art of sonic anemometry concerning wind engineering applications has been presented, underlining the advantages of this kind of anemometers with regard to other types (mainly cup anemometers) and also the difficulties that sonic anemometers should overcome to be considered as the suitable sensor for wind energy applications. In fact, there exists a lack of experimental background in sonic anemometer characterization, carried out in high quality wind tunnels, which the industrial users can trust. The other situation to be solved is the lack of a standard calibration procedure which helps to the industrial application. Both tasks have been evidenced within COST 14 EU actions and have been studied within the ACCUWIND project framework where, additionally, some procedures to define cost effective calibration processes have been explored.

A range of sonic anemometers have been calibrated in wind tunnel by DEWI and IDR in two different wind tunnels with different tilting mechanisms, see Figure 4-6.



Figure 4-6 Gill Wind Master sonic during calibration at DEWI wind tunnel with tilting mechanism (left) and at IDR wind tunnel with tilted mounting on turn table (right), both methods keeping sensor centre at same position in wind tunnel during calibrations

The analysis of the test results of different sonic anemometers (both 2D and 3D units) in the two different wind tunnels have revealed the existence of non-negligible differences in the way the different sensors measure the magnitude of the wind speed vector, the wind direction and the wind speed inclination angle. These differences appear mainly for large inclination angles of the sensors, see for example measurements on the Gill Wind Master in the IDR wind tunnel in Figure 4-7, and measurements on three different 3D sonics in the DEWI wind tunnel in Figure 4-8.

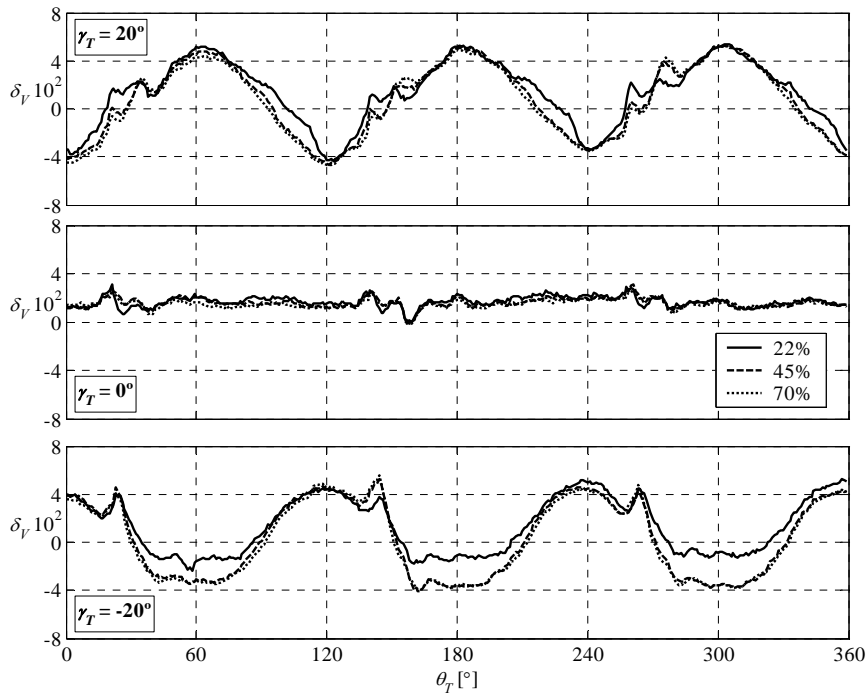

Figure 4-7 Results for the percentage deviation in the measurement of the total wind speed as function of the true wind direction relative to the sensor for three different inclination angles. Percentages indicating wind speed (22%≐4.34 m/s; 45%≐9.89 m/s and 70%≐15.99 m/s). Gill Wind Master at IDR wind tunnel

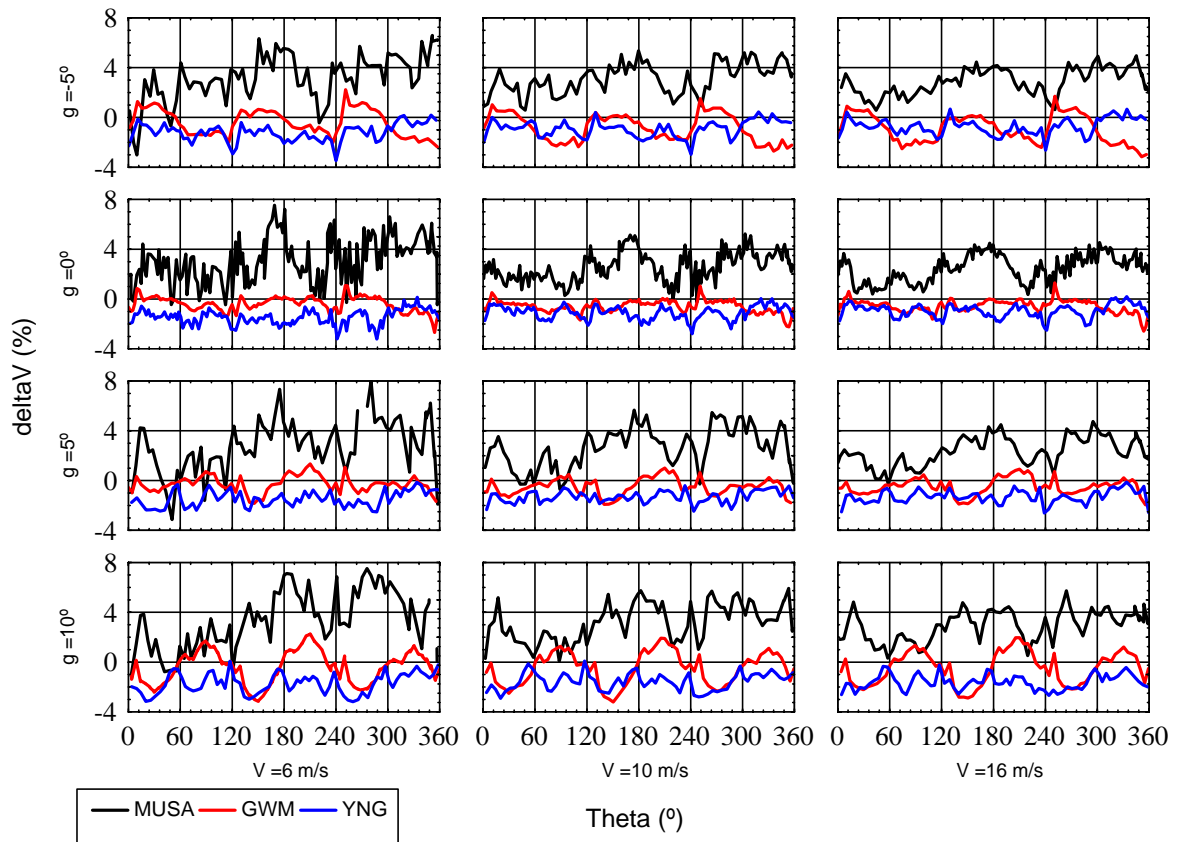

Figure 4-8 Results for the percentage deviation in the measurement of the total wind speed as function of the true wind direction relative to the sensor for four inclination angles and three wind speeds. DEWI wind tunnel.

The wind speeds measured over almost the full year of 2005 with 3D Gill Wind Master sonic anemometers have been compared to wind speeds measured with calibrated Risø cup anemometers on a mast at ECN Wind Turbine Test Station Wieringermeer. Comparisons has been carried out for anemometers at 52m height and at 80m height, see Figure 4-9.

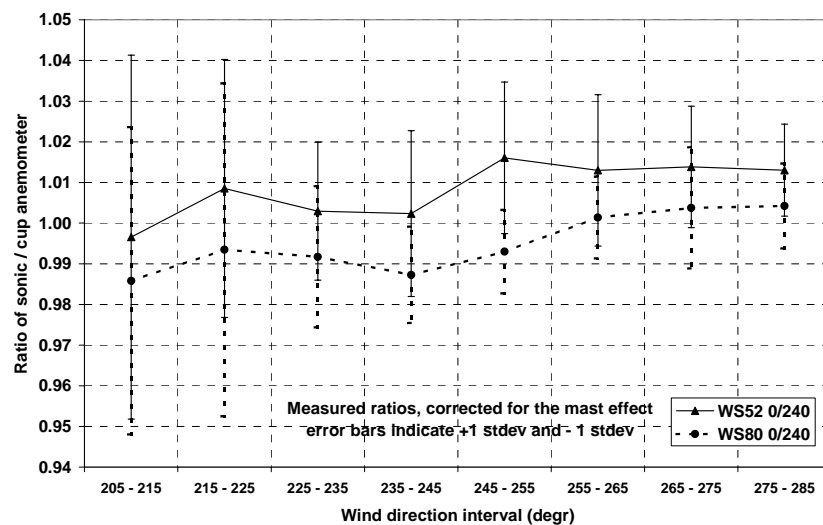

Figure 4-9 Ratios (corrected for mast and boom effects) between the Gill Wind Master sonic anemometer (0° boom direction) and the cup anemometer (240° boom direction) at 52m and at 80m, including the $+1\sigma$ and -1σ error bars.

The average ratios of the wind speeds measured with the sonic anemometer over the wind speeds measured with the cup anemometer averaged over the undisturbed wind direction range and all wind speeds above 4 m/s, is 1.009 at 52m height and 0.996 at 80m height. Taking into account the uncertainty of the cup anemometers and the applied corrections for the mast disturbance effects it is concluded that no significant differences could be observed between the results from the two types of anemometers.

Some methods for reducing the calibration time of sonic anemometers in wind tunnel have been explored. Algorithms for azimuth change by steps and for continuous azimuth change were developed.

A classification procedure for sonic anemometers have been proposed and applied to two different sonics. Both sonic units are not calibrated in wind tunnel. Even in this situation the k values are comparable to cup anemometers [7]. It is observed that if the deviation in a calibration process can be reduced remarkable the same would occur with the k values. The results correspond to two units tested in one wind tunnel. It must be assessed if a single sonic unit is representative of the certain model type. It has also been evidenced that some differences exist in the characterization of different units of the same sonic model in two different wind tunnels. Therefore the verification of the robustness of the method is still pendant. In spite of the previous comments, the results are quite promising.

A test rig for comparison of anemometers has been established, which compares a test anemometer with a reference Solent R3A sonic anemometer and a reference Risø cup anemometer.

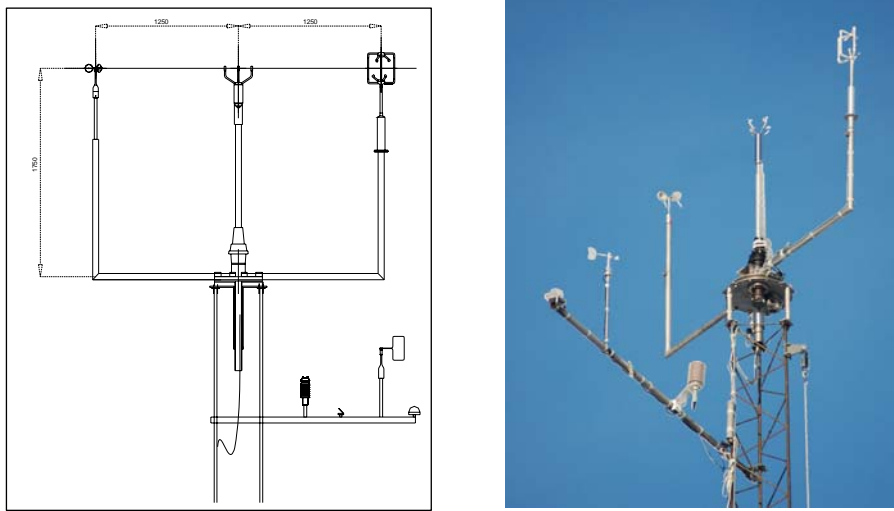

Figure 4-10 The sonic field comparison test rig with a Solent R3A sonic and a Risø cup anemometer as reference and the test sonic in the middle and influence parameter sensors on a boom below

The test rig boom on the 30m mast orients itself to the wind. On another stationary boom, below the rotating boom, sensors for measurement of atmospheric parameters, such as temperature, humidity and radiation are mounted. Additionally, rain and pressure are measured at 2m level. A large database of data has been gathered from testing of five commercial sonic anemometers: WindMaster, WindObserver II, METEK USA-1, Vaisala WAS425 and Young 81000. Data have been filtered and analysed for dependency of the atmospheric parameters. The measured relative differences to the Solent R3A are shown in Figure 4-11.

Very few data were left after filtering of the METEK and Young data, and too few for determination of significant dependencies. A relatively high spreading of deviations was found on the Vaisala sonic below 7m/s. These data seemed to depend substantially on the temperature. Otherwise, no significant dependencies of atmospheric parameters were found. Icing or hoar frost deposit conditions were observed at temperatures close to 0°C, but data were filtered out in the analysis. Wind turbine wake conditions were analysed and it was found that such wake conditions have a significant influence on the comparison measurements due to a significant horizontal wind shear. Wind turbine wakes should therefore always be excluded in field comparisons. The deviations of the test sonics and the reference cup anemometer to a “calibrated” R3A were plotted in a graph indicating classes according to the IEC standard on power performance measurements. The graph indicates Class A categories for flat terrain of the sonics, although this analysis does not fulfil the criteria for a classification.

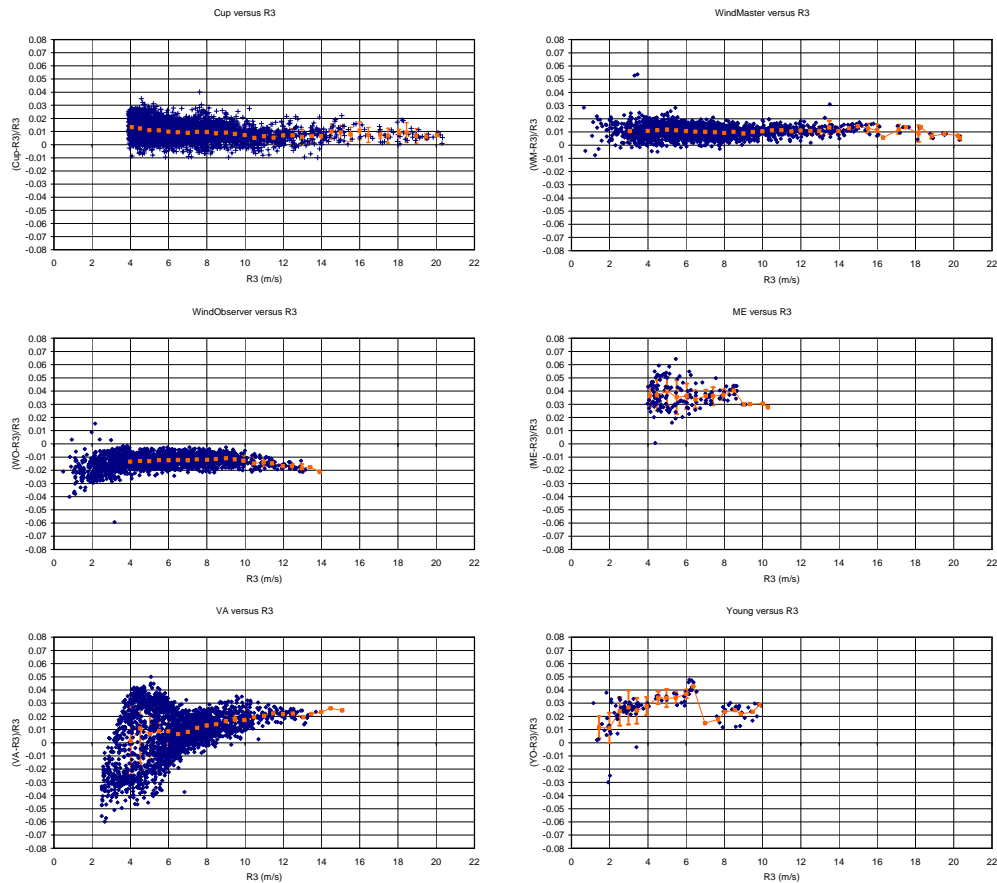

Figure 4-11 Relative difference of cup and test sonic anemometers to Solent R3A sonic measured on sonic field comparison test rig

4.4 Task 3 Definition of Wind Speed

The work on a better definition of wind speed for a power curve is reported in [13].

The better knowledge of wind turbine behaviour in the atmosphere and assessment of power performance of wind turbines under various atmospheric conditions is pushing for increased accuracy in wind speed measurements. It is recognised that power production of the turbine depends on vertical inflow angle, turbulence intensity and other parameters.

The effects of vertical inflow and turbulence intensity on the power performance was investigated using advanced aero elastic codes PHATAS and GAST. The results show that the power is reduced significantly with inclined inflow and the dependency is significantly larger than a cosine relationship. Note that the results are not symmetrical around zero vertical inflow angle, since the rotor plane has an angle with the vertical. Normalised results are summarised in Figure 4-12 where, in addition, powers of the cosine dependency are indicated. The dependency on the vertical inflow angle is stronger than the \cos^2 dependency, for the Vestas turbine more likely the \cos^3 dependency. The stall regulated NKT turbine even has a stronger dependency than the \cos^4 dependency for the lowest wind speeds.

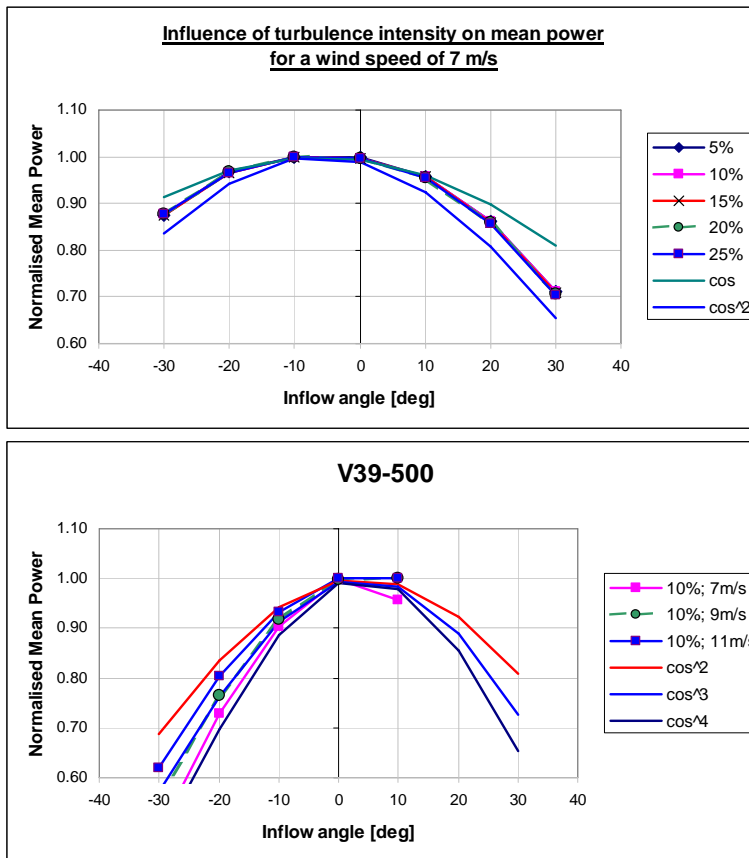

Figure 4-12. Normalised power of pitch regulated wind turbines simulated with PHATAS (upper) or GAST (lower) as function of inflow angle. The powers of the cosine dependency on the inflow angle are indicated additionally.

The other parameter of interest is the turbulence intensity. The dependency of the generated power on turbulence intensity as shown in the simulations is significant. For the PHATAS simulations, the power is normalized to the level at 5% turbulence intensity at zero inclined flow which is summarized in Figure 4-13. For the GAST simulations, the normalized results are also summarised in Figure 4-13.

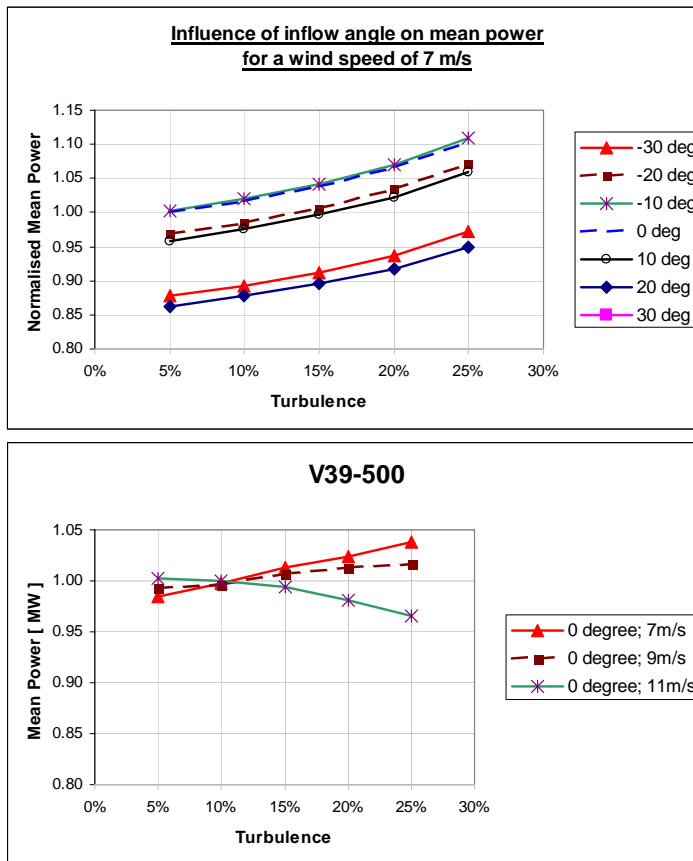

Figure 4-13. Normalised power simulated with PHATAS (upper) and GAST (lower) as function of turbulence intensity for pitch regulated turbines.

Basic theoretical analyses of wind turbine behaviour as well as several experimental evidences show that the averaged and standard deviation values of electrical power of a wind turbine during a certain period (10 minutes) are correlated with different statistical parameters associated with the wind speed and air density characteristics during that period. This has been shown based on data from existing databases. Usually, the power curve of a wind turbine is obtained experimentally as the relationship $P_{10}=f(u_{10})$. This definition implies that the variability induced on P_{10} by other statistical wind descriptors are treated as natural variability of the test leading to scattering in the relationship $P_{10}=f(u_{10})$ and, therefore, uncertainties in the annual energy production (AEP) calculations. In wind energy studies, there is a frequent need to reduce AEP uncertainties. In some cases even site-specific power curves are supplied.

One way to achieve better and more reliable power curves is to introduce the influence of secondary parameters in power performance analyses through the definition of generalised power curves. However, the definition of a generalised power curve as a relationship $P_{10}=f(u_{10},\rho_{10},\dots)$ presents difficulties from a technical points of view, but also need to be accepted from a marketing or economical point of view. The analytical search for generalised power curve explored the idea to include wind shear and the three wind speed component variances in the power performance analyses.

Using neural networking to determine the sensitivity of the power performance on a large set of parameters showed that the captured effects of turbulence intensity and air density are qualitatively in accordance with what was expected. The magnitude of the air density effect deviates from what is expected from the current linear normalization practices. The effects of wind shear are significant, because they reveal the effect of the rotor average wind speed on power curve.

The developed procedure enables the exploitation of experimental power curve data in order to define multiple power curves, each one corresponding to specific wind inflow characteristics. Thus, the known effects of turbulence, air density, shear and/or wind inclination can be quantified and expressed with the multiple power curves. In order to capture the corresponding wind inflow characteristics information, higher demands for the reference mast instrumentation have to be met:

- wind shear information should be captured using anemometers at different heights;
- wind inclination should be captured using sonic anemometers and
- turbulence characteristics need to be assessed using sonic anemometers.

All the theoretical and experimental investigation performed within the framework of the ACCUWIND project, along with relevant bibliographic data lead to the conclusion that the effects of wind characteristics to wind turbine power output are qualitatively comparable but when it comes to the quantification of the effects then it is seen that these effects depend strongly on turbine size and type. As such, the only way to enhance the accuracy of the power curve is to introduce more wind structure parameters and use analysis procedures in order to define generalised power curves.

5 General Conclusions

The ACCUWIND project on improvement of assessment and classification methods have given some significant results, which are valuable for the wind energy sector for assessment of the accuracy of cup and sonic anemometers, and also for improvement of the design of cup and sonic anemometers.

An innovative new approach on measurement of torque characteristics of cup anemometers by the use of a wind tunnel gust generator for vertical as well as tilted conditions have been demonstrated to give good results that compare well to measurements with static torque sensors and traditional tilt response measurements. The new approach have given rise to a new cup anemometer model, the IFTC model, which has been used in classification of five cup anemometers, and compares satisfactorily with another model using static torque and tilt response measurements, the TRTC model. The use of two different cup anemometer models, two different tilt response measurements, with and without friction, was supposed to demonstrate a significant robustness of the classification method described in the IEC 61400-12-1 standard, but the results were not fully satisfactory. The tilt response measurements from different wind tunnels, for instance, showed significant variations in classification indices, which indicate the need of more consistent procedures for tilt response measurements of cup anemometers. Especially the tilt response characteristics around the vertical position are extremely sensitive to the class index results.

The problems of wind tunnel blockage in cup anemometer calibration was investigated by running three significantly different sizes of cup anemometers in five different wind tunnels of various cross section sizes. The results did show the influence of blockage in the different wind tunnels, but the results are not fully consistent, and in some cases it was contradictory. On this background, unfortunately, the blockage correction factor problems evidenced by the MEASNET organization were not resolved in general.

The interest in the wind energy community to use sonic anemometers for average wind speed measurements as alternatives to cup anemometers was the basis for the significant activities on the assessment of this type of sensor. Contrary to the cup anemometer, the characteristics of this type of sensor are not very well understood in the wind energy sector. Better assessment methods, calibration and field application procedures may give enough

confidence for inclusion of this type of sensor in the next revision of the IEC61400-12-1 standard. The most important issues focused on in this work were the wind tunnel calibrations and field application influence parameters. Sonics are not used to be calibrated traceably in accredited wind tunnels, for instance as within the MEASNET organization. Sonic manufacturers often claim their instruments to be calibrated once and for all, and customers do not need regular calibrations of the instruments. The wind tunnel calibrations and field tests showed that there are significant measurement differences between the instruments, which is quite unsatisfactory within the wind energy community. A procedure for regular calibrations (or check of calibration) in accredited wind tunnels is needed for sonics. Recommendations were given in the project for calibration and applications in the field. The field comparison tests did not reveal significant influence parameters, such as temperature, humidity, pressure and rain. Only in one case a temperature dependency was found significantly influential. The field test results indicate that the most important influences on sonics are the sensor head and support structure flow deviations, which are detected during wind tunnel calibrations with full azimuthal and tilt angle variation, and implemented either as internal correction values or within a general classification based on systematic errors. The investigations showed in general very promising characteristics of the sonic anemometers, which should lead to a broader acceptance for average wind speed measurements when the common basic procedures that are described are implemented.

The investigations wind turbines of the influence of turbulence, flow inclination angle and wind shear indicate that the simple power curve definition with the electric power and single point hub height wind speed measurement is insufficient on the larger wind turbines. The analysis clearly shows that wind inflow characteristics over the swept area are significantly dependent on the inflow angle, the turbulence and wind shear. There seem to be significant advantages in the provision of more detailed information on the power curve, which as a consequence will show less scatter in data. A revised power curve definition is recommended for the next revision of the IEC61400-12-1 standard, including a revised reference mast instrumentation that comprises anemometers at different heights to capture wind shear information and sonic anemometers to capture wind flow inclination and turbulence characteristics.

6 References

- [1] Albers A., “SiteParIden; Relative Power Curve Measurements in Flat Terrain, Final report of Task 6”, report JOR3-CT98-0257-DEWI07, 13 June 2001-12-07
- [2] Curvers A.P.W.M., van der Werff P.A., “SiteParIden; Relative Power Curve Measurements in Complex Terrain, Final report of Task 7”, report ECN-C-01-102, October 2001
- [3] Albers A., Klug H., Westermann D. ”Outdoor Comparison of Cup Anemometers”, DEWEK 2000
- [4] Albers A., Klug H., ”Open Field Cup Anemometry”, EWEC 2000
- [5] Dahlberg J.-Å., Gustavsson J., Ronsten G., Pedersen T.F., Paulsen U.S., Westermann D., “Development of a Standardised Cup Anemometer suited to Wind Energy Applications”, Contract JOR3-CT98-0263, Publishable Final Report; June 2001
- [6] Dahlberg J.-Å., Pedersen T.F., Westermann D., “Development of a Standardised Cup Anemometer suited to Wind Energy Applications, CLASSCUP”, EWEC 2000
- [7] IEC 61400-12-1, first edition 2005-12, Wind turbines – Part 12-1: “Power performance measurements of electricity producing wind turbines”
- [8] Pedersen T.F. “Development of a Classification System for Cup Anemometers – CLASSCUP”, Risø-R-1348(EN), December 2002
- [9] Dahlberg J.-Å., Pedersen T.F., Busche P., “ACCUWIND – Methods for Classification of Cup Anemometers”, Risø-R-1555(EN), May 2006
- [10] Pedersen T.F., Dahlberg J.-Å., Busche P., “ACCUWIND – Classification of Five Cup Anemometers According to IEC61400-12-1”, Risø-R-1556(EN), May 2006
- [11] Dahlberg J.-Å. ‘An investigation of wind tunnel blockage effects on cup anemometer calibrations’, FOI-R-2006-SE, June 2006
- [12] Cuerva A., Sanz-Andrés A., Franchini S., Eecen P., Busche P., Pedersen T.F., Mouzakis F., “ACCUWIND – Accurate Wind Measurements in Wind Energy, Task 2. Improve the Accuracy of Sonic Anemometers, Final Report”, UPM/IDR Madrid June 2006
- [13] Eecen P.J., Mouzakis F., Cuerva, A “ACCUWIND, Work Package 3 Final Report”, ECN-C-06-047, May 2006

Mission

To promote an innovative and environmentally sustainable technological development within the areas of energy, industrial technology and bioproduction through research, innovation and advisory services.

Vision

Risø's research **shall extend the boundaries** for the understanding of nature's processes and interactions right down to the molecular nanoscale.

The results obtained shall **set new trends** for the development of sustainable technologies within the fields of energy, industrial technology and biotechnology.

The efforts made **shall benefit** Danish society and lead to the development of new multi-billion industries.