

## Wind atlas analysis and application program (WAsP)

**Mortensen, Niels Gylling; Landberg, Lars; Rathmann, Ole Steen; Frank, Helmut Paul; Troen, I.; Petersen, E.L.**

*Published in:*

Wind Energy Department: Scientific and technical progress 1999-2000

*Publication date:*

2001

*Document Version*

Publisher's PDF, also known as Version of record

[Link back to DTU Orbit](#)

*Citation (APA):*

Mortensen, N. G., Landberg, L., Rathmann, O., Frank, H. P., Troen, I., & Petersen, E. L. (2001). Wind atlas analysis and application program (WAsP). In B. Skrumsager, & G. C. Larsen (Eds.), Wind Energy Department: Scientific and technical progress 1999-2000 (Vol. Risø-R-1239(EN))

## DTU Library

Technical Information Center of Denmark

---

### General rights

Copyright and moral rights for the publications made accessible in the public portal are retained by the authors and/or other copyright owners and it is a condition of accessing publications that users recognise and abide by the legal requirements associated with these rights.

- Users may download and print one copy of any publication from the public portal for the purpose of private study or research.
- You may not further distribute the material or use it for any profit-making activity or commercial gain
- You may freely distribute the URL identifying the publication in the public portal

If you believe that this document breaches copyright please contact us providing details, and we will remove access to the work immediately and investigate your claim.

**Wind Energy Department:  
Scientific and Technical Progress  
1999 - 2000**

**Birthe Skrumsager and Gunner Chr. Larsen (eds)**

**Abstract**

The activities of the Wind Energy Department fall within boundary layer meteorology, atmospheric turbulence, aerodynamics, aero-acoustics, structural dynamics, machine and construction technology and design of power systems and power system controls. The objective is to develop methods for design; test and siting of wind turbines; prediction of wind loads and wind resources as well as methods to determine the dispersion, transformation and effect of air pollution.

The present report describes the organisation of the department and presents selected scientific highlights and results from the two-year period 1999-2000. Additional information on the department and its activities can be found on World Wide Web (WWW) on the address <http://www.risoe.dk/vea/>. The department's web pages are constantly updated.

ISBN 87-550-2818-7  
ISBN 87-550-2819-5(internet)  
ISSN 0106-2840

Print: Danka Services International A/S, 2001

## Contents

<b>1</b>	<b>Introduction</b>	<b>5</b>
<b>2</b>	<b>The Department of Wind Energy and Atmospheric Physics</b>	<b>5</b>
<b>3</b>	<b>Aeroelastic Design</b>	<b>7</b>
3.1	Determination of damping for edgewise blade vibrations	8
3.2	Airfoil design	9
3.3	Numerical wind tunnel	10
3.4	Modal analysis of wind turbine blades	11
3.5	Aeroelastic stability	12
<b>4</b>	<b>Atmospheric Transport and Exchange (ATU)</b>	<b>13</b>
4.1	Air-sea exchange of gases	14
4.2	Atmospheric dispersion - nuclear safety applications	15
4.3	Atmospheric dispersion	16
4.4	Air-vegetation exchange	17
4.5	Satellite remote sensing for surface fluxes and winds	18
4.6	A simple model for the boundary-layer height and its application	19
<b>5</b>	<b>Electric Design and Control</b>	<b>20</b>
5.1	Advanced control of wind turbines	21
5.2	Simulation of wind power plants	22
5.3	Power quality	23
<b>6</b>	<b>Wind Power Meteorology</b>	<b>24</b>
6.1	Wind Atlas Analysis and Application Program (WAsP)	25
6.2	WAsP engineering	26
6.3	Short-term prediction	27
6.4	CleverFarm	28
6.5	Measurements and modelling of offshore wind	29
<b>7</b>	<b>Wind Turbines</b>	<b>30</b>
7.1	Contract with the Danish Energy Agency	31
7.2	Design basis for offshore wind turbines	32
7.3	Guidelines for Design of Wind Turbines	33
<b>8</b>	<b>Wind Turbine Diagnostics</b>	<b>34</b>
8.1	High quality measurements	35
8.2	Power curve measurements in complex terrain	36
<b>9</b>	<b>Measuring and Data Technology</b>	<b>37</b>
9.1	Development of data acquisition equipment	38
9.2	Monitoring atmospheric climate variables	39
<b>10</b>	<b>Risø International Wind Power Consulting</b>	<b>40</b>
10.1	National wind turbine test station in India	41
<b>11</b>	<b>Wind turbine testing</b>	<b>42</b>
11.1	Experimental investigation of ultimate loads	43
<b>12</b>	<b>The Wind Turbine Blade Testing Centre (Sparkær Centre)</b>	<b>44</b>
12.1	Fatigue blade tests	45
12.2	Static blade test	46
<b>13</b>	<b>Exploratory Projects</b>	<b>47</b>
13.1	Laser anemometry for control and performance measurements on wind turbines	48
13.2	The atmospheric boundary of Mars from the Pathfinder data	49

13.3 A turbulent diffusion experiment	50
13.4 Hybrid power systems with photovoltaics and wind power	51

## 1 Introduction

This report contains a description of the research programmes and tasks of the department as well as selected highlights and results from the two-year period 1999-2000.

The purpose of the report is to supplement the obligatory annual reports, which for this department focuses on factual information. Thus the report aims to illustrate the scientific and technical achievements of the period in a more readily accessible manner. In addition to the central results of the research programmes and special tasks, a number of exploratory projects are presented.

Additional information on the department and its activities can be found on World Wide Web (WWW) on the address <http://www.risoe.dk/amv/>. The departments web pages are constantly updated.

## 2 The Department of Wind Energy and Atmospheric Physics

The departments research activities on wind energy and atmospheric processes have the overall objective to advance

- the competitiveness of the Danish wind power industry, setting the scene for implementation of the national energy policy in the area of wind energy and furthering the global application of wind power, and
- the atmospheric physics basis of assessment and forecast of wind effects, transport, conversion and exchange of atmospheric gases and particles in relation to climate studies, air pollution and accidents.

Hence the department aims to meet the need for new knowledge and consultancy assistance on wind turbine technology and the exploitation of wind energy, as well as to map atmospheric processes and alleviate airborne pollution. The research is carried out in co-operation with industry and other users of the research results and in close collaboration and in alliances with national and foreign universities and research organisations.

The activities of the department fall within the Risø program area *Wind Energy and Atmospheric Processes*. It has the objective to develop methods for design; test and siting of wind turbines; prediction of wind loads and wind resources as well as methods to determine the dispersion, transformation and effect of air pollution. The department is organised in programs and special tasks according to its main research and technical activities.

Research programmes:

- Aeroelastic Design
- Atmospheric Transport and Exchange
- Electrical Design and Control
- Wind Power Meteorology
- Wind Turbines
- Wind Turbine Diagnostics

Special tasks:

- Experimental Meteorology
- International Wind Power Consulting
- Wind Turbine Testing
- Wind Turbine Blade Testing Centre, Sparkær

The "Aeroelastic Design" programme involves the key issue development and use of aeroelastic codes, computational fluid dynamics (CFD) codes and design tools for wind turbine blades and airfoils as well as wind tunnel measurements of airfoil section flows. The codes are used for establishment of design load basis for wind turbines, further development of the three-bladed horizontal axis wind turbine concept and development of new wind turbine concepts.

In the "Atmospheric Transport & Exchange Programme" basic research into boundary-layer meteorology and atmospheric turbulence is carried out. In addition we study environmental problems related to transport of air-borne pollutants and turbulent exchange of matter in the interaction between the atmosphere and terrestrial or sea surfaces.

The programme “Electrical Design and Control” aims to lower the cost of wind energy by optimising the wind turbine as well as the grid interface and operation of the power system. The research involves topics such as control concepts for wind turbines; electrical components; grid connection and large-scale wind energy penetration; hybrid power supply systems and energy storage Combined with renewable energy sources. Since spring 2000 the research programme has been implemented in a strategic alliance with the Institute of Energy Technologies at Aalborg University.

The “Wind Power Meteorology” programme is aimed at assessments of wind resources for power production and wind loads on wind turbines and other wind sensitive structures. The programme comprises development of models and software, field measurements and in-house as well as commissioned assessment studies.

The “Wind Turbine” program conducts strategic and applied research in load and safety, experimental verification, technical/economical analysis of wind energy’s utilisation in grids and in hybrid energy systems. Our research within this program supports our consultancy activities for Danish and international authorities, organisations, banks and investors regarding wind energy projects. It also supports our participation in international standardisation. The programme hosts the wind turbine type approval and certification activities, which are performed in an alliance with Det Norske Veritas.

The “Wind Turbine Diagnostics” program conducts strategic research to develop method for experimental determination of wind turbine characteristics, including test methods aimed for use by the wind turbine industry.

The special task “Experimental Meteorology” serves as a departmental expert in organising and conducting field meteorological measurements, providing instruments, data systems, data management and organisation. It serves the research programs of the department and also external customers. In year 2000 the name was change to Measurements and Data Technologies as a consequence of the re-structuring of Risø’s support departments.

The special task “International Wind Power Consulting” aims to utilise the knowledge and state-of-the-art tools available at Risø to provide consulting and technical advice concerning international projects on the development and application of wind power technology.

The special task “Wind turbine Testing” offers its expertise in measuring techniques for wind turbine testing at Risø and from field measurements.

The special task “ Wind Turbine Blade Testing Centre, Sparkær” is accredited for static and dynamic fatigue test of wind turbine blades and it is offering this to Danish blade producers at the test centre in Sparkær. By the end of 2000 the Sparkær Centre is able to test blades with a length of up to 42m, both statically and dynamically.

In 2000 the department engaged 105 man-years, 7 of which involved PhD students and post-doctoral researchers. The departmental structure by the end of 2000 is illustrated in the block diagram below.

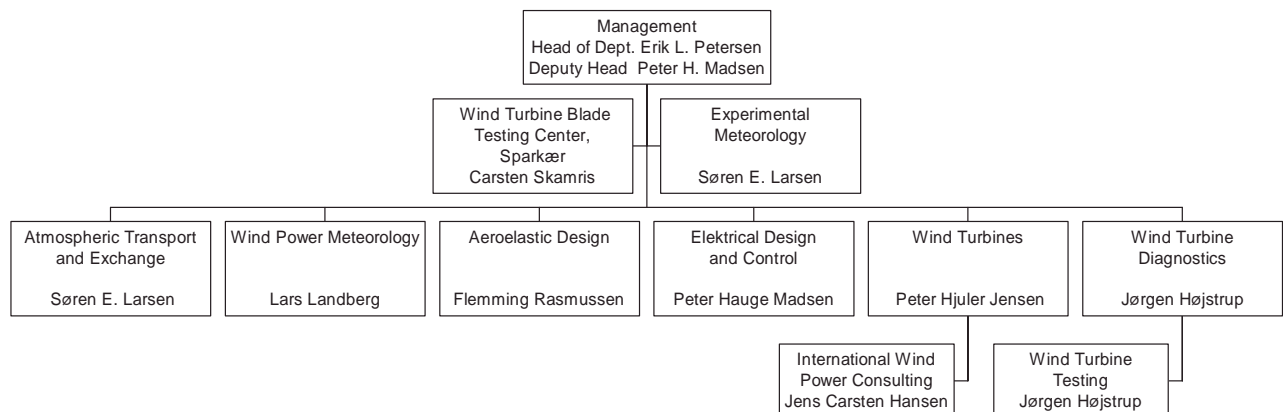

The key areas of scientific expertise in the department are boundary layer meteorology, atmospheric turbulence, aerodynamics, aero-acoustics, structural dynamics, machine and construction technology and design of power systems and power system controls. The fields are advanced exploiting full-scale field tests, laboratory tests and advanced numerical simulation.

### 3 Aeroelastic Design

*Flemming Rasmussen*

The programme Aeroelastic Design is aiming at the development and use of advanced computational tools in combination with experimental verification to establish the relevant design, load basis and assist in finding the optimal design, of both wind turbine components and complete wind turbines.

**Aerodynamics** Two- and three- dimensional Navier-stokes computations of the air flow forms the basis for the continuous developments of the "Numerical Wind tunnel" and are very useful in the development of simpler and computationally inexpensive engineering models. In combination with numerical optimisation, aerodynamic engineering models are used to design new wind turbine airfoils followed by experimental verification in the wind tunnel.

**Structural dynamics** Finite element analysis and experiments (both full scale and in test stand) give information on strength, mode shapes, eigenfrequencies, stability and damping of the different components composing a wind turbine.

**Aeroelasticity** Aeroelasticity describes the interaction between the elastic deformation of the wind turbine structure and the aerodynamic forces. The research within Aeroelasticity is aimed at developing and improving the aeroelastic models for wind turbines. Many results of this research are implemented in the aeroelastic code HawC. Besides acting as a "test stand" for improved aeroelastic modeling, this code is used in the wind turbine industry for the development of new MW-size wind turbines.

**New concepts** The traditional three-bladed concept is continuously improved as part of the programme's work, but also new concepts are examined. An example is the two-bladed, dynamically flexible wind turbine.

#### **Development and results 1999-2000**

**Aeroelasticity and wind turbine design.** Aeroelastic factors are of major practical importance in the design of wind turbines. In co-operation with a manufacturer, Risø has developed and tested a method for experimentally determination of the damping of blade vibrations for an operating turbine. This allows improvements in aeroelastic calculation models, leading to more accurate predictions of loads and dynamics. In addition, it can be used for documentation of the characteristics of an existing turbine in connection with certification. In the same context, the aeroelastic code HawC has been expanded to allow modelling of mechanical vibration dampers in the turbine nacelle and tower, so that optimisation can be carried out by means of aeroelastic calculation. In addition, a method has been developed for experimental determination of the oscillation modes of a wind turbine blade. The oscillation modes measured are compared with existing aeroelastic models, in which the blade modes shapes are of major significance to the dynamic stability of the entire wind turbine. The methods that have been developed are now being implemented in industry. Much effort has been on the determination of stability of blades and the entire wind turbine structure. Stall-induced vibrations is one type of instability which has been analysed with the above described methods including detailed Finite Element modelling of the blades, which has led to formulation of design guidelines. However, with the increasing size and flexibility of wind turbine blades, another type of instability, called classical flutter, could emerge. A model for the prediction of flutter has been developed, and HawC has been extended to estimate the limit to flutter for existing blades, and is as well suitable also for design of new blades against flutter.

**The numerical wind tunnel.** "The numerical wind tunnel" has been continuously developed and applied for analysis of flow phenomena related to the design and operation of wind turbines. Extreme wind conditions for a blade during stand still has been modelled using CFD. This has revealed a characteristic three-dimensional flow pattern that causes a load distribution deviating from previous assumptions. The verification of this is being done by comparisons to measurements on wind turbines at extreme wind conditions. The verification of "The numerical wind tunnel" predictions for an entire operating turbine represents a great challenge due to the high complexity of the problem and the large number of parameters. An important step forward is expected on this point by comparisons to a wind tunnel experiment with a full-scale 10-m wind turbine performed by NREL in the NASA Ames large wind tunnel. Predictions of the different test cases have been performed in advance and have subsequently been compared to the test results showing excellent agreement. The CFD tools have also been developed and applied for analysis of the complex flow interaction by the blade passing the tower. This represents a highly unsteady flow condition, which affects the flow on the whole blade for quite some azimuth angles of the blade rotation, and thus the dynamic response of the blade. The analysis leads to a better formulation and tuning of the engineering sub-model for blade-tower interaction, that is part of the aeroelastic simulation code. A modification to the leading edge of the existing stall-regulated wind turbine blades has been designed, ensuring a more stable stall. Thus, it is possible to avoid several different power levels occurring at high winds, as is the case with some wind turbines today. At the same time, the modification makes the blades a little more aerodynamically efficient and ensures that the performance of the blade is less sensitive to dirt on the leading edge. The modified airfoil section has been tested in wind tunnel, which showed excellent accordance with predicted characteristics.



### 3.1 Determination of damping for edgewise blade vibrations

*Kenneth Thomsen*

Violent edgewise blade vibrations have in recent years been a large problem for some stall regulated wind turbines. Due to the complexity of the phenomenon it has been difficult to predict the risk of these vibrations with aeroelastic load prediction tools. One of the problems regards the choice of parameters in the aeroelastic model, e.g. structural damping and aerodynamic airfoil characteristics. In many cases a high degree of uncertainty exists and the need of experimental verification methods is large.

In this project, a new method to identify the effective damping for the edgewise blade mode shape for wind turbines has been developed. The method consists of an exciter mechanism which makes it possible to excite the edgewise blade mode shapes from the wind turbine nacelle, and furthermore it consists of an analysis method which enables a straightforward determination of the damping. The analysis method is based on a local blade whirl description of the edgewise blade vibrations.

The method has been verified on a Bonus wind turbine, and for this specific turbine the effective damping for edgewise blade vibrations has been determined.

The potential of the method is that the results can support the further development of aeroelastic models and fine tuning of parameters of importance for the edgewise blade vibration problem and thus improve the reliability of the predicted risk of vibrations.

Furthermore, the method can be used for experimental investigation of the risk for edgewise blade vibrations for a specific turbine.

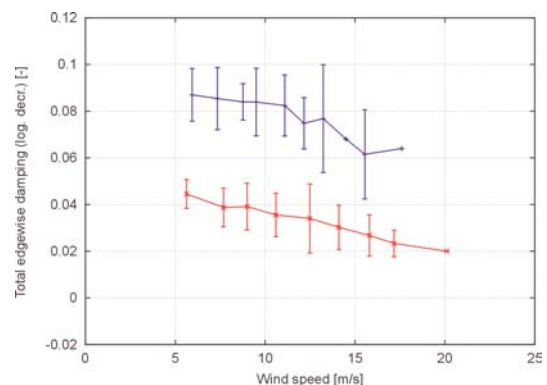

The work has been funded by the Danish Energy Agency under the contracts Danish Energy Agency ENS 1363/98-0006 and ENS 1363/00-0006. Bonus Energy A/S designed the excitation mechanism and carried out the measurements. Other project partners were LM Glasfiber A/S and the Technical University of Denmark.

## 3.2 Airfoil design

Christian Bak

Desirable characteristics for wind turbine airfoils differ significant from traditional aviation airfoils. This was the motivation for the development of the airfoil design tool, *AIRFOIL*, at Risø in the past five years. This tool uses the flow solver *XFOIL* in combination with numerical optimisation. Changing the airfoil shape fulfils the design objectives. Constraints on the airfoil shape, aerodynamic forces and flow parameters can be set to control the resulting characteristics.

Using the design tool we have designed several airfoil families tailored for wind turbines to achieve improved stalling characteristics, greater aerodynamic conversion efficiency and elimination of the double-stalling tendency. Two examples of such airfoils developed and tested in the past two years, will be presented in the following.

The first example is the design of the Risø-A1 airfoil family composed of seven airfoils ranging in thickness from 12% to 30%, Figure 1.

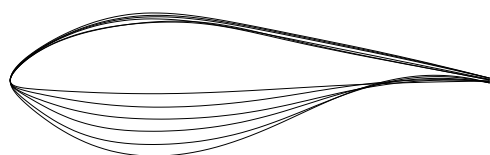

Figure 1 The contours of the Risø-A1 airfoil family.

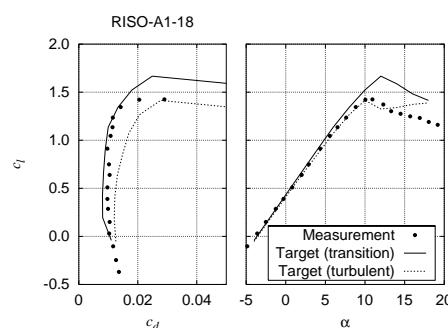

Figure 2 Measured and computed airfoil characteristics for Risø-A1-18.

The design is based on Reynolds and Mach numbers representative of a 600 kW wind turbine. The airfoils are designed to have maximum lift-drag ratio until just below stall, a design lift coefficient of about 1.55 at an angle of attack of  $10^\circ$  and a maximum lift coefficient of 1.65. Furthermore, the airfoils are insensitive to leading edge roughness such as bugs and dust, which is important to maintain peak power in dirty environments. Wind tunnel tests in the VELUX wind tunnel, Denmark, verified the design method as shown in figure 2. Measured lift and drag coefficients agree well with the computed aerodynamic characteristics. The airfoils are at the moment being tested on a full-scale 600 kW active stall regulated wind turbine in Denmark.

The second example is the design of a new leading edge for the commonly used wind turbine airfoil NACA 63-415, Figure 3, to avoid double stall and thereby loss of power.



Figure 3 The NACA 63-415 airfoil with modified leading edge.

The design tool was developed so that only a small part of the airfoil shape changed in the numerical optimisation. The limited change of the airfoil ensured that the mounting of the new leading edge on existing blades was feasible. Apart from avoiding double stall the new leading edge was designed to increase lift-drag ratio until just below stall, to reduce roughness sensitivity and to have the same maximum lift coefficient compared to the NACA 63-415 airfoil. As for the Risø-A1 airfoil family wind tunnel tests in the VELUX wind tunnel verified the design method. Double stall was avoided, the airfoil efficiency increased with 8% at angles of attack corresponding to 8m/s without leading-edge roughness and with leading-edge roughness the efficiency increased with up to 40% at angles of attack corresponding to peak power. Furthermore, the aerodynamic damping and the dynamic stall characteristics were unchanged. Thus, all design objectives were fulfilled also for real flows.

### 3.3 Numerical wind tunnel

Niels N. Sørensen

The numerical wind tunnel, is a collection of numerical tools related to aerodynamics and aeroelasticity, centred around the parallel EllipSys general purpose Navier-Stokes solver. The EllipSys solver is developed in co-operation between The Department of Energy Engineering at DTU and the Wind Energy and Atmospheric Physics Department at Risø. As the use of a numerical tool typically is much less expensive and faster than carrying out an experiment, it allows evaluation of different designs before validating the final design with measurements.

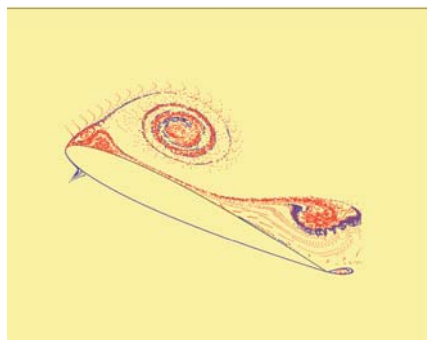

Figure 1 Dynamic stall vortex on a NACA-0015 airfoil

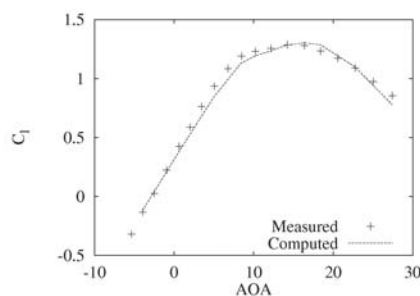

Figure 2 Comparison of measured and computed  $C_l/\alpha$  curve for the Risø-1 profile at  $Re=1.6 \times 10^6$

Steady and transient two-dimensional airfoil flows are areas, where the EllipSys program is intensively used. The capability of the code to compute laminar/turbulent transition is extremely important for these applications, as the precise location of the transition point is essential for predicting the correct airfoil characteristics, see Figure 1. In connection with unsteady airfoil characteristics, the code is being used to compute dynamic stall flows, see Figure 2. As an extension to this the EllipSys program has recently been coupled to a simple three degrees of freedom elastic model, which allows direct computations of the aeroelastic behaviour of airfoil sections. Computations of the flow around rotors have for the last few years been investigated in the numerical wind tunnel. This type of work is extremely demanding regarding both CPU time and mesh generation. The 3D mesh generated by the in-house HypGrid2D/HypGrid3D programs are shown in Figure 3.

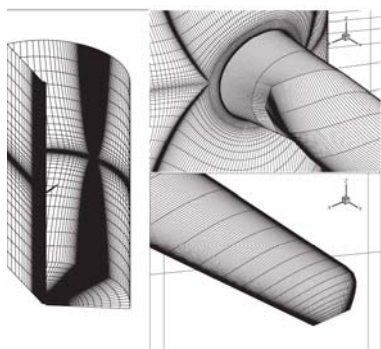

Figure 3 Mesh for rotor computation showing a total view of the mesh and details near the root and the tip.

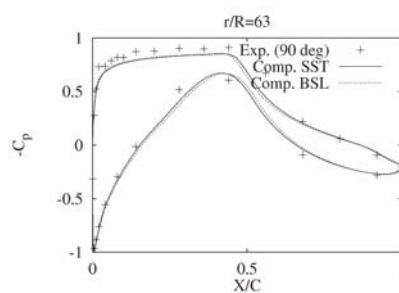

Figure 4 Predicted and experimental pressure distributions at the  $r/R=0.63$  section for the NREL Phase-II rotor at 7 m/s wind speed.

These computations provide detailed informations about the flow, e.g. pressure distributions (Figure 4), skin friction distributions and limiting stream lines on the surface, which usually are not available from full scale measurements on wind turbines. At the moment the numerical wind tunnel is used to perform blind computations of the NREL/-NASA AMES 180x120 wind tunnel experiment of the NREL Phase 6 rotor. The Danish Energy Agency under contract ENS-1363 funded the work with the numerical wind tunnel.

### 3.4 Modal analysis of wind turbine blades

Morten H. Hansen

The stability analyses of the interaction of blade and airflow (cf. “Aeroelastic Stability” by M.H. Hansen & J.T. Petersen) have shown the need of accurate knowledge of the mode shapes of the blades of wind turbines. Today this knowledge is obtained from finite element methods with only little experimental verification. With the aim of improving the standards of blade testing and the verification of numerical models, a method for estimating the mode shapes of blades based on modal analysis has been developed and tested on the LM 19.1 meter blade.

The chosen modal analysis method is called *Impact Modal Testing* (Figure 1). A specially designed hammer excites the blade and a force transducer mounted on the hammer tip measures the excitation force. Three accelerometers are mounted on the blade to capture its flapwise, edgewise, and torsional vibration in a particular cross-section. Then, using frequency response analysis, the modal deflections in this cross-section of the modes in the considered frequency band are calculated from the measured responses and force. By measuring the responses in many cross-sections, the mode shapes can be estimated in the whole length of the blade.

The results are high accuracy estimations of natural frequencies and damping (Figure 2) and estimations of the mode shapes (e.g. 1<sup>st</sup> edgewise mode in Figure 3). Accurate estimations of flapwise and edgewise deflections were obtained, but this particular experiment shows some difficulty in the estimation of torsion. Further improvements of the setup (e.g. measurement of geometry and signal quality) are needed in the future to solve this problem.

The comparison of the estimated mode shapes to mode shapes computed by the aeroelastic code HawC has helped the verification of the aeroelastic calculations performed with HawC. This was one aim for the development of a modal analysis procedure. In the future modal analysis is expected to become part of the standard blade-testing program and to play a vital role in the development and verification of numerical models of blades as well as complete wind turbines. The Danish Energy Agency under contract ENS 51171/97-0043 funded this work.

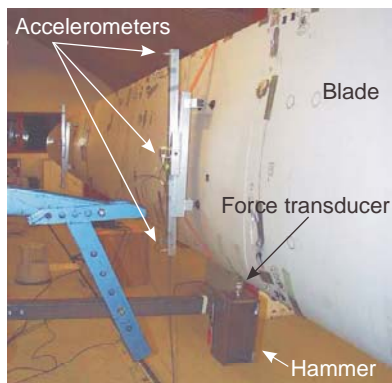

Figure 1: Part of the experimental setup.

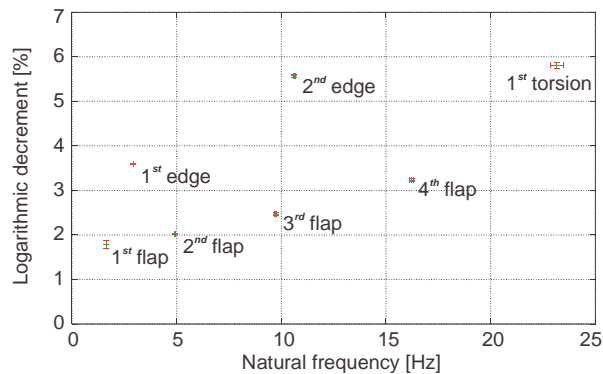

Figure 2: Estimated natural frequencies and damping of LM 19.1.

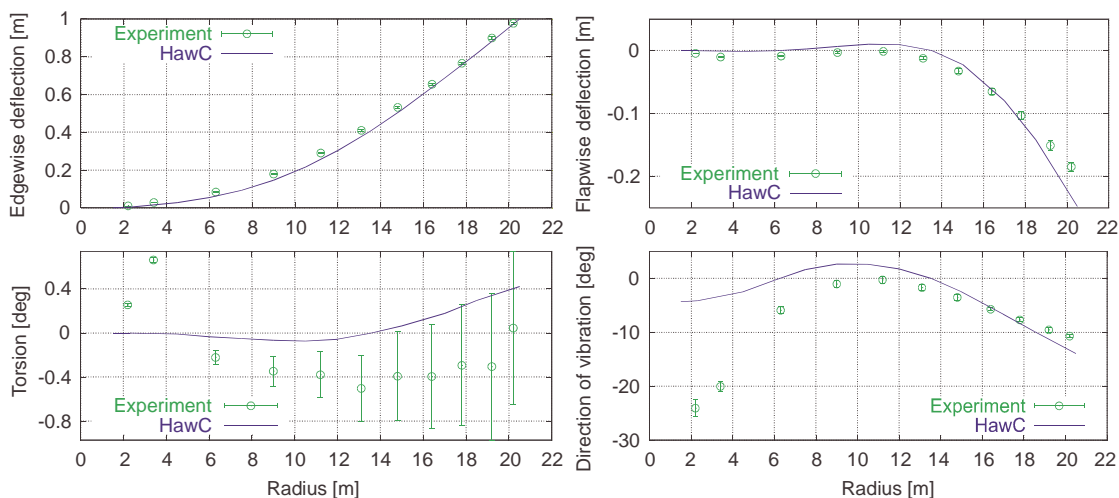

Figure 3 Estimated 1<sup>st</sup> edgewise mode shape of LM 19.1 compared to a calculation with the aeroelastic code HawC.

### 3.5 Aeroelastic stability

Morten H. Hansen and Jørgen Thirstrup Petersen

A part of the research in the Aeroelastic Design Program deals with the development of a tool for predicting the stability of a wind turbine. To understand the tasks ahead, the problem has been simplified by studying the stability of only a section of the blade. Through these studies it has become clear that rotor-blade interactions through the dynamics of the nacelle and tower are important phenomena (cf. “Determination of Damping for Edgewise Blade Vibrations” by K. Thomsen). However a fundamental understanding of certain instabilities have also been obtained from these studies. Two types of instabilities related to the aeroelastic coupling of blade section and airflow are considered to be important for a wind turbine: *Stall induced vibrations* (Figure 1) and *classical flutter* (Figure 2).

Stall induced vibrations can occur at wind speeds where the airflow is separated from the surface of the blades. The studies show that the combination of negative slope of the lift curve and low drag coefficient may result in negative aerodynamic damping of blade vibration. Edgewise vibrations are most critical, but even small changes in the direction of vibration are important. To predict the risk of stall induced vibrations the mode shapes must therefore be known (cf. “Modal Analysis of Wind Turbine Blades” by M.H. Hansen). The instability is avoided by carefully choosing the aerodynamic properties of the blades (cf. “Profile Design” by P. Fuglsang & C. Bak).

Classical flutter can occur at low angles of attack where the airflow is attached to the blade surface (the case for pitch regulated wind turbines). The studies have shown that blades with the natural frequencies of the first torsion and first flapwise mode relative close to each other can experience flutter. When a blade with such properties encounters a high airspeed, the frequencies of its torsion and flap vibration nearly merge and the modes may interact in a violent instability. The only way to avoid this instability is to change the structural properties of the blade.

These fundamental understandings of aeroelastic instabilities for blade sections have been used directly in the analysis of real wind turbines. Furthermore, the studies have shown the way in the development of the aeroelastic stability tool for the complete wind turbine. This tool will lead to a greater understanding of these instabilities under influences of rotor-blade interactions through the dynamics of the nacelle and tower. The Danish Energy Agency under the contracts ENS 1363/98-0006 funded the work and ENS 1363/99-0011 and the Technical University of Denmark were partners.

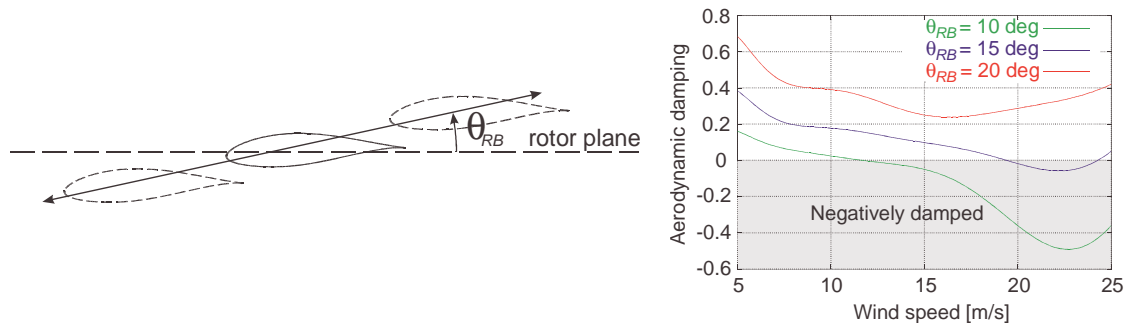

Figure 1 The risk of stall induced blade vibration depends on the direction of vibration  $\theta_{RB}$  and the aerodynamic properties of the blade. The calculation of aerodynamic damping is here based on quasi-steady aerodynamics.

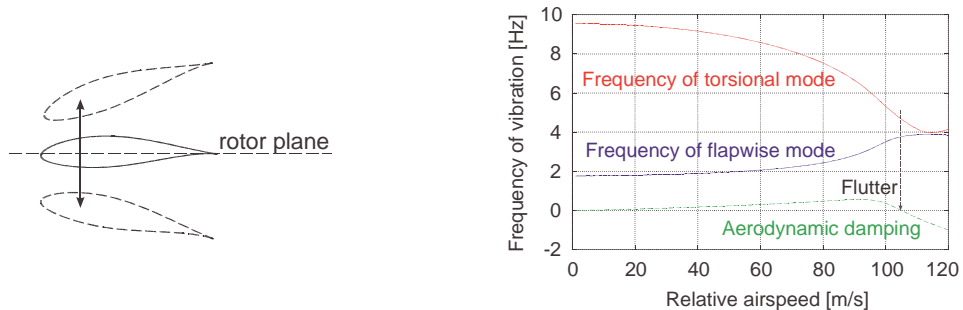

Figure 2 The risk of a flutter instability at low angles of attack depends on the frequency separation of first flapwise and torsion modes of the blade. They must be close for flutter to occur. The frequencies of vibration and the aerodynamic damping for the critical vibration mode are here calculated from an aeroelastic eigenvalue problem based on Theodorsen’s unsteady potential flow solution.

## 4 Atmospheric Transport and Exchange (ATU)

*Søren E. Larsen*

### Objective

To contribute with new knowledge about 1) atmospheric motion and transport, and 2) atmospheric exchange with terrestrial and aquatic ecosystems aiming at environmental evaluations and recommendations, or emergency preparedness.

### Mid-term goals

Through long-term research effort within boundary-layer meteorology, climatology, atmospheric turbulence, experimental meteorology and surface characterisation, to:

- 1: Develop boundary-layer meteorological models for dispersion, transport, exchange of natural and anthropogenic substances, in order to forecast, describe and reduce environmental effects of airborne material.
- 2: Develop, utilise and improve sensor and data systems for atmospheric measurements and surface characterisation for model validation and documentation of atmospheric transport, dispersion and exchange.
- 3: To develop multi-scale dispersion models for airborne pollution from point sources with extended use of meteorological and geographical information systems and databases, and to integrate these systems in computer-based emergency preparedness systems.
- 4: To develop and systematise knowledge about climatology and surface characteristics for use in connection with the climate aspects of the research of the department, especially climate observations and wind climatology.
- 5: Participate in development of a national centre for atmospheric research.

### Selected developments and results from 1999-2000

The effort within boundary layer meteorology, climatology and atmospheric turbulence is one of the oldest on-going activities at Risø going back to the dispersion climatological measurements initiated at the start of Risø in 1957. Within the report period there has been continuing development across all mid-term goals, as listed above:

- 1: A wide variety of activities and projects have focused on dispersion. The activities have ranged from a laboratory experiment presenting new results on isotropic diffusion, to series of boundary layer diffusion experiments on dispersion of odours around pig-farms and on accidentally released industrial gases, most recently HF. The study of surface fluxes over different types of surfaces has mainly focused on the exchange of CO<sub>2</sub> and Nitrogen compounds between the atmosphere and both the ocean and terrestrial ecosystems, aiming to establish local and regional scale budgets, as well as better understanding of key processes. In co-operation with national and international partners, ATU have contributed the improved knowledge about both processes and budgets in the reporting period. Part of the output from the forest activity is validation of a Soil Vegetation Atmosphere Transfer (SVAT)-model that is also a milestone within the contract between the Danish Ministry of Research and Information Technology and Risø.
- 2: The experimental work and instrument development has always been an important part of the Risø meteorology work. Within the reporting period the RISØ LIDAR has been improved and utilised for series of experiments for measuring dispersion and concentration fluctuations. It is presently being tested for measurements of the boundary layer height. The Risø Relaxed Eddy Accumulation system (REA) has been extensively used and improved as tool for flux measurements of different species, such as HNO<sub>3</sub> and CO<sub>2</sub>, VOC and NH<sub>3</sub>. Application of satellite and other remote sensing data together with Geographical Information Systems (GIS) have been developed to a practical tool for surface characterisation in connection with wind modelling and surface flux aggregation.
- 3: This goal reflects a continuing participation in emergency preparedness systems developed for nuclear emergencies, where a Risø local scale flow model and puff dispersion model is integrated both in the Nordic system, ARGOS-NT, and the system developed by the European Commission, RODOS. The RODOS system delivery by the end of 1999 has been a milestone in the contract between Risø and the Danish Ministry of Research and Information Technology. The same systems are being used for minimising the effects of airborne spreading of Aujeszky's disease.
- 4: Modified and improved boundary layer closure relations have been obtained for use in numerical atmospheric models. They are presently being implemented in climate models and weather forecast models. New results have been obtained on surface flux and roughness aggregation (specifying the relations between large scale and small-scale roughness), implementation of roughness for scalars, and improved flux parameterisation for boreal conditions.
- 5: Danish Society for Atmospheric Research (DSAR) has been defined primarily in co-operation with The Danish National Environmental Research Institute and the Danish Meteorological Institute, but with substantial contributions from Universities and other institutions as well. In parallel, scientists from ATU serve in a wide variety of collegiate bodies; notably as President of Ocean and Atmosphere within the European Geophysical Society, and as chair of the Scientific and Organising Committee for the NATO/CCMS International Technical Meetings on Air Pollution Modelling and its Application (ITM).

#### 4.1 Air-sea exchange of gases

Lise Lotte Sørensen, Søren Larsen, Hans E. Jørgensen and Morten Nielsen

The air-sea gas exchange projects of the department are focused mainly on the greenhouse gas CO<sub>2</sub>, or on the exchange of nitrogen compounds to establish eutrophication load from the atmosphere to the sea, or on both to study the links between CO<sub>2</sub> exchange and nitrogen exchange through the biological importance of both. EC is a key sponsor for many of the CO<sub>2</sub> exchange projects: 1) The OMEX-project to determine the Carbon budget at the European Atlantic Ocean margin; 2) Two process studies, the ASGAMAGE-project conducting field measurement over the North Sea, and the Luminy-project, utilising laboratory experiments in the air-sea facility in Marseilles; 3) An instrument project, the AutoFlux-project, aiming to develop and test an autonomous flux monitoring system for unattended use on buoys or ships (the system aims also to measure fluxes of CO<sub>2</sub>). In addition a Danish Research Council project, aiming at investigating the atmospheric transport and air-sea exchange of particulates and CO<sub>2</sub> in the North East Atlantic Region, was initiated in 1997 (Atlantic CO<sub>2</sub> and Particulates, NEAREX).

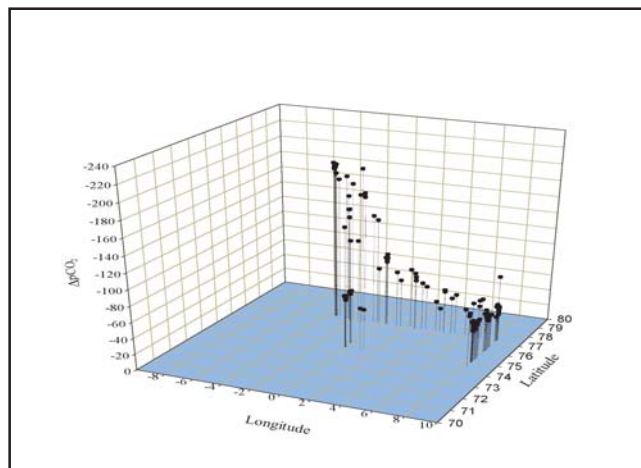

Most existing parameterisations of the air-sea flux of CO<sub>2</sub> are based on the CO<sub>2</sub> partial pressure difference between the atmosphere and the ocean and an exchange coefficient depending on wind speed and solubility of CO<sub>2</sub> (the ΔpCO<sub>2</sub> method). Recently also micrometeorological flux estimation has become possible. Model calculations of CO<sub>2</sub> exchange in oceanic areas are based on the assumption of an average pCO<sub>2</sub> difference and a mean wind speed. However, measurements carried out during a cruise in the Greenland Sea in the project NEAREX show large differences in ΔpCO<sub>2</sub> even within short distances, see figure. For homogeneous conditions we have generally found good agreement between the two methods. However in horizontal inhomogeneous areas, as coastal regions or the NEAREX area, shown on the figure, we have found systematic disagree-

ments between the micrometeorological measurements and the measurements carried out by the ΔpCO<sub>2</sub> method, consistent with the estimates of the importance of advection for such areas.

The department also participates in several international projects on air-sea exchange of nitrogen species where the main task for the department is to measure and parameterise the air sea exchange of the gaseous Nitrogen species. The air-sea flux process has been studied in the EU-MAST project BASYS. In this project measurements have been conducted at a small island west of Gotland in the Baltic Sea. The measurements have shown that typically about half of the HNO<sub>3</sub> scavenging is related to exchange between the gases and the wet marine aerosols, so a smaller amount of HNO<sub>3</sub> than first expected is deposited into the marine waters in gas phase. This means that the fraction transported on the aerosol is larger than expected. A main conclusion from this work is that the deposition of nitrogen into the marine water is very much depending on the wind speed while deposition velocities for aerosols are smaller than for gases at low wind speeds but larger at high wind speeds (>10 ms<sup>-1</sup>) (Pryor and Sørensen, 2000). New parameterisation of nitrogen fluxes is being implemented in atmospheric models based on the results from the BASYS project. The model is validated within the Nordic Council (NMR) project: Air-sea Exchange, which is co-ordinated by the department.

In the EC project ANICE, fluxes of HNO<sub>3</sub> and NH<sub>3</sub> to the North Sea has been measured from a platform (Meetpost Noordwijk) 10 km from the Dutch coast. The surface exchange of NH<sub>3</sub> is more difficult to measure than HNO<sub>3</sub> since NH<sub>3</sub> is not as soluble as HNO<sub>3</sub>. Therefore the exchange of NH<sub>3</sub> is partly controlled by the concentration in the water. Also the surface concentration was found to be horizontally heterogeneous, so the classical flux equations need some adjustment, similar to the situation for CO<sub>2</sub> during NEAREX as discussed above. During ANICE it was found that NH<sub>3</sub> at times is emitted from the marine waters. The emission was found mainly to take place during night, during on shore winds and in the end of the growth season when the algae are not taking up nutrients.

The air-sea exchange projects have been conducted as extensive national and international co-operative projects, with NERI, University of Copenhagen and DMI as the main Danish partners.

Pryor, S. and Sørensen L.L., 2000, Nitric Acid- Sea salt reactions: Implications for nitrogen deposition to water surfaces. *Journal of Applied Meteorology*, **39**, 725-731.

## 4.2 Atmospheric dispersion - nuclear safety applications

Torben Mikkelsen

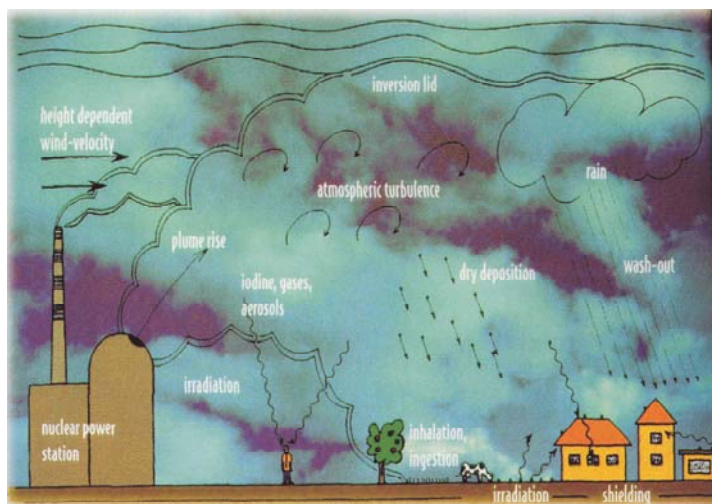

### Advising government

In Risø's terms of references, as given by the Danish Government, advisory support in nuclear matters is stipulated. As national centre, Risø support the Danish Emergency Management Agency (Beredskabsstyrelsen) with expertise and decision support tool for use during nuclear emergencies. Our departments role (within VEA/ATM) has in this connection traditionally been concerned with prediction and assessment on atmospheric dispersion and deposition of radioactive material. This activity started at Risø some 40 years ago, with the establishment of the Risø meteorological tower (123 m). It continued with consequence assessments for potential Danish and foreign nuclear power plants in cooperation with the Danish Authorities.

Risø's nuclear atmospheric dispersion surveillance and prediction activities were boosted by the 1986 Chernobyl accident. In collaboration with Nordic and European sister organisations, and aided by Nordic and European Funding agencies (NKS, European Commission) new real-time decision support systems have been designed (RODOS, ARGOS-NT) to assist emergency management with decision support during nuclear accidents. The departments role has been to design and implement comprehensive atmospheric dispersion forecast systems for radionuclides dispersion in nuclear emergency support systems.

### Dispersion model RIMPUFF

A central computer code in most of the departments dispersion and deposition work is the RIMPUFF local scale puff diffusion simulation tool. When connected to numerical weather forecast centres via the Internet, it provides national forecasts of air concentration, deposition, and gamma dose rate for airborne and ground deposited radionuclides. RIMPUFF provides local scale diffusion and atmospheric deposition parameters as well as local scale wind fields for plume and puff transport. It integrates local scale turbulence and transport models and micro-meteorological pre-processing algorithms.

### Wind model LINCOM

Models for the wind and turbulence field is important for prediction of the puff trajectory, exposure, and the clouds time of arrival. Our LINCOM local scale model system provides RIMPUFF with winds and turbulence data for 1) local hills; 2) thermal stratification; and 3) the surface roughness changes. In addition, a Sea breeze wind model is presently being developed for coastal dispersion assessment (and for coastal wind resource estimation as well).

### Nuclear research programme activities

A new Fifth Framework joint EU research activity ENSEMBLE addresses the problem of achieving a common coherent strategy across European national emergency management for national Long-range dispersion. Another new EU research project DAONEM seeks to improve the predictive capabilities of decision support systems by developing and implementing data assimilation tools. The department participates also in a European exercise network DSSNET for better communication and understanding between the decision support systems operational community. The department has engaged in several experimental campaigns (MADONA) and experimental studies with the purpose to evaluate the modules.

### Related activities (animal interspersed, malodour, virus)

Animal farm inter-spread by airborne pathogenic virus and bacteria is a concern, which can be assessed and mitigated by atmospheric dispersion modelling. The department is engaged in animal welfare related projects with RIMPUFF, with the purpose to assess and minimise inter-spread, it being Aujeszky's disease, odour nuisance for the surrounding neighbours, and studies of airborne disease transmission between stables.



### 4.3 Atmospheric dispersion

Hans E. Jørgensen, Torben Mikkelsen, Morten Nielsen & Søren Ott<sup>1</sup>

The modern society does not accept massive air pollution and regulates the emissions from industrial production. The health and general wellbeing of neighbours and employees need to be protected, both during normal operation and in the case of accidental gas releases. This often calls for technical solutions or safety strategies of considerable cost for the manufacturer, so decisions on improvement are usually based on a consequence analyses. Atmospheric dispersion plays a central role in these calculations and it is an active research area at Risø.

The problems of practical interest are sometimes complex, e.g. malodour is mainly caused by short-term peaks. A person in the neighbourhood of a stack release may feel uncomfortable in turbulent airflow with occasional downdrafts, even when the average concentration is acceptable. Similar conclusions may be drawn in relation to toxic effects or the risk of gas ignition. Hazardous chemicals stored in pressurised or refrigerated containers pose another assessment challenge, since accidental gas releases from these sources will have temperature and buoyancy different from those of air, and the resulting density effect influences the dispersion process.

The Risø research in the area of atmospheric dispersion is significantly supported by field experiments. To ease the data analysis and the comparison with models we generally conduct experiments in flat terrain. This enables accurate detection of upstream profiles of wind, turbulence and other meteorological parameters. We prefer a simple source with well-defined release properties like emission rate, buoyancy, jet momentum, and the geometry of possible buildings and obstacles is kept reasonably simple. Most often the choice has been neutrally buoyant smoke or a high momentum two-phase jet. The gas detection depends on the objectives and technical possibilities of the specific experiment, e.g. availability of sensors for a particular gas. The overall dimensions of the gas field are detected by arrays of sensors deployed in arcs across the plume or mounted in masts near the centreline. In experiments with thermal buoyancy effects thermocouples supplement the gas detectors. For detection of concentration fluctuations we adopt a remote sensing LIDAR (light detection and ranging) instrument developed at the department. This instrument detects the instantaneous concentration distribution along a laser beam either oriented in a fixed direction or swiftly scanning a two-dimensional plane.

Our research in atmospheric dispersion has led to important new results. Turbulence was measured inside the gas clouds of our cold heavy-gas experiments. We observed turbulence damping by density stratification, though not as much as expected from previous isothermal heavy-gas dispersion experiments. This difference is explained by turbulence production from heat transfer from the warm ground to the cold gas cloud, a process, which also modifies the cloud density. Both factors are mitigating effects in the perspective of risk analysis. The data from the LIDAR instruments have an excellent spatial resolution and sequential LIDAR profiles reveal that large-scale turbulent motions sweeping the plume from side to side mainly cause the concentration fluctuations. When we analyse the concentration fluctuations in a moving-frame of reference following the instantaneous plume centreline, the in-plume fluctuations are separated from the plume-sweeping effect. With a limited sample period, i.e. a few hours, these moving-frame analyses produce much more accurate statistics than fixed frame analyses. These statistics are used to construct a semi-empirical model for concentration fluctuations in industrial gas releases. Our smoke plume experiments further suggest that the correct scaling parameter for the two-particle distance-neighbour function in the surface layer should be the friction velocity, not the energy dissipation, as often assumed in the literature. This result has implications for particle diffusion and wind loads on structures.

Public research programmes have sponsored most of the work on atmospheric dispersion, in particular the ENVIRONMENT & CLIMATE and RADIATION PROTECTION programmes of the Commission of the European Communities. The typical project partners are wind-tunnel laboratories and experts on computational fluid dynamics. The overall objective is to promote industrial and nuclear safety and our general role is to provide the knowledge for other parties to implement in useful models. We also acknowledge the support of the Danish Pig Farmers Association, who have supported work concerning the airborne spread of Aujeszky's disease and has an interest in minimising malodour related to ventilation of large pig stables.



*Experimental release of hydrogen fluoride (HF) within the URAHFREP EU project. It is tested whether cloud buoyancy, produced by a reaction between HF and atmospheric humidity, would be sufficient to lift the toxic plume off the ground.*

<sup>1</sup>Systems Analysis Department

#### 4.4 Air-vegetation exchange

Niels Otto Jensen, Ebba Dellwik and Kim Pilegaard (PBK)

Our micrometeorological expertise has over the recent years been utilised in the measurements of fluxes of contaminants (air pollution) as well as water vapour and CO<sub>2</sub> between terrestrial ecosystems and the atmosphere. The methods used are the classical mean profile method, the eddy co-variance method and various forms of the relaxed eddy-accumulation technique. For air pollution compounds such as NO<sub>x</sub> and ozone the main objective is to determine the so-called deposition velocity  $v_d = F/C$  where  $F$  is the flux of the compound and  $C$  is the air concentration. Often this parameter is found not to be a constant but varies according to the plant's photosynthetic activity. Other studies in the same family are concerned with emissions of hydrocarbons from the plants (e.g. isoprene,  $\alpha$ - and  $\beta$ -pinene, etc.) and hence the contribution by the terrestrial ecosystems to the general level of air pollution. Estimates are that these "natural emissions" contribute more than half of the background level of aerosol particles in the air.

List of projects	Ecosystem	Compounds of major interest
RIMI	Grass land	NO <sub>x</sub> , CO <sub>2</sub> , ozone, evaporation
GEFOS	Agriculture (grass, barley)	CO <sub>2</sub> , N <sub>2</sub> O, CH <sub>4</sub>
BEMA	Orange plantation	Biogenic hydrocarbon emissions
FOREXNOX / SMP II	Beech forest	Deposition of NO <sub>x</sub> and ozone
EUROFLUX / SMP II	Beech forest	CO <sub>2</sub> and evaporation

Another example of these air-vegetation exchange studies is the long-term measurements of CO<sub>2</sub> sequestration by forest ecosystems. We participate in two such studies, in a spruce plantation in Western Jutland and in a beech forest in Sorø (56°N) on the island of Zealand. The latter is part of the EUROFLUX project comprised of about 30 similar flux stations in Europe which again are part of a world wide network called FLUXNET. Measurements of the carbon exchange between the Sorø forest and the atmosphere has shown that the net uptake (the sequestration which consists of a balance between the photosynthetic uptake and the respiratory losses) is about 150 gC/m<sup>2</sup> per year, but with relatively large variations from year to year. Over four years of measurements it ranges from 71gC/m<sup>2</sup> in 1998 to 227 gC/m<sup>2</sup> in 1999 which is about ±53%. The measurements have shown that especially the temperature and the soil water content are determining factors for the observed variations. It is a challenge, on the basis of these measurements, to improve the physical parameterisation in the so-called SVAT (Soil Vegetation Atmosphere Transfer) models.

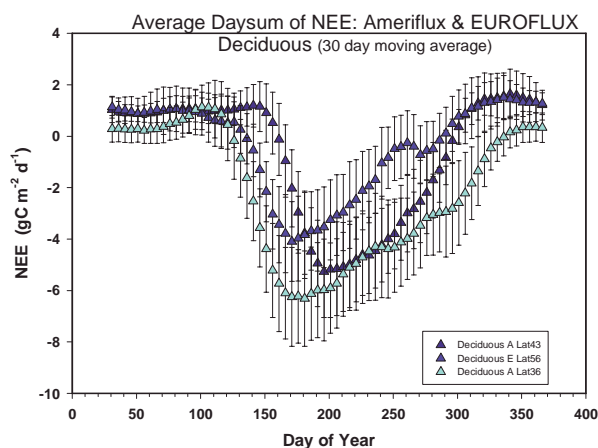

The figure (taken from Baldocchi *et al*, 2000<sup>\*)</sup> shows the annual pattern in 1997 of daily CO<sub>2</sub> exchange at Sorø (net ecosystem exchange, NEE, in grams of carbon per m<sup>2</sup> per day) compared to two other deciduous forests, Oak Ridge, TN (36°N) and Harvard Forest, Petersham, MA (43°N), both USA. Negative values mean a flux downward, or uptake. Forests lose carbon during the winter because of respiration from the system. During the summer growing season the photosynthesis dominates and results in a net uptake. There is some difference in the maximum rate of uptake with increasing tendency towards the south. However, what differs most among sites is the timing of the transition between gaining and losing carbon. The northerly site at Sorø becomes a net carbon sink later in the spring, and respire earlier in the autumn

than the southerly site Oak Ridge in Tennessee. This reflects the length of the growing season. Harvard forest is sort of in between the two other results except that it starts its activity at the latest stage (40 days after Oak Ridge) probably due the influence of the continent towards the north east and hence a very late spring.

\*)Baldocchi *et al*. "FLUXNET: A New Tool to Study the Temporal and Spatial Variability of Ecosystem-Scale Carbon Dioxide, Water Vapour and Energy Flux Densities". Submitted to *Bulletin of the American Meteorological Society*, October 2000.

#### 4.5 Satellite remote sensing for surface fluxes and winds

Charlotte Bay Hasager and Niels Otto Jensen

Satellite remote sensing of land surface parameters has been combined with aggregation modelling and air pollution transport models. Surface flux aggregation modelling describes the non-linear turbulent atmospheric processes in the microscale range, i.e. 10 m – 10 km. In heterogeneous terrain the individual land surface patches may vary in aerodynamic roughness, surface temperature and surface humidity. The horizontal variations cause local effects on the vertical transport of momentum, heat, water vapour and other scalars such as CO<sub>2</sub>, nitrogen or radioactive deposits. The horizontal length scale of the surface variations is a key parameter in the atmospheric modelling. For very large patches, i.e. > 10-20 km, the surface flow will be in equilibrium with the underlying surface, for smaller patches non-equilibrium flow conditions exists. The atmospheric flow does not “forget” the upwind conditions. The aggregation model is two-dimensional in the horizontal domain and Fast Fourier Transforms solve the linearised flow equations. The so-called microscale aggregation model is applicable in real terrain and is computationally fast. The model is validated by surface flux measurements from tall meteorological masts as well as model results derived from detailed models on idealised forms of terrain. The aggregation values are useful for validation of hydrological modelling at small catchment scale. Furthermore does the aggregated model output provide “effective” roughness values useful in large-scale atmospheric models. Currently the “effective” aggregation values are being tested at Danish national level for weather forecasting and regional climate prediction modelling in Northern Europe.

List of projects	Applied satellite information
RS-model	land surface flux, aggregation, hydrological cycle and CO <sub>2</sub>
SAT-MAP-CLIMATE	land surface flux, aggregation, operational weather forecasting and regional climate modelling
WATERMED	land surface flux, aggregation, hydrological cycle in dry Mediterranean area
SFINCS	land surface flux, aggregation at regional scale for climate system modelling
ARGOS-NT	land surface parameters for real-time air pollution deposition modelling
Wind atlas for Egypt	land surface parameter mapping for wind energy
Tanzania	coastal surface wind mapping for wind energy
WEMSAR	ocean surface wind mapping for off-shore wind energy
MEAD	ocean surface parameter mapping for alga blooms caused by atmospheric nitrogen deposition

The figure shows a map of the calculated surface momentum flux for the Rhine Valley<sup>2</sup>. The wind comes from North. The momentum flux is very high at the leading edge of the forests and gradually decreases downwind from the smooth to more rough land surfaces. The momentum flux is low for the river. The aggregation consists of averaging these pixel values of surface fluxes.

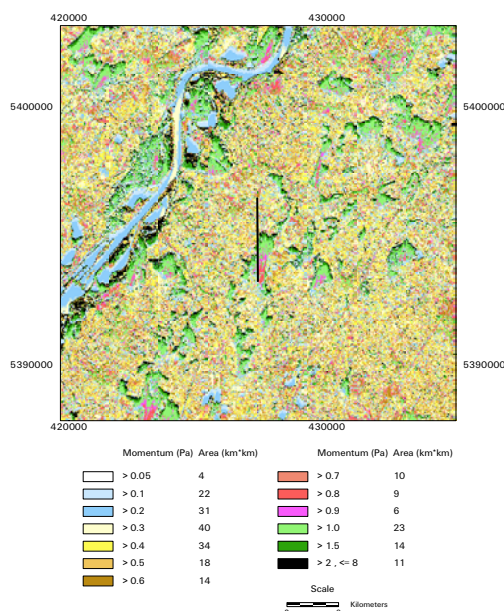

Momentum flux map for a wind speed of 5 m/s from North at 4 m height for summer 1993 based on Landsat TM.

The satellite remote sensing data for land surface studies comes from the optical wavebands from medium- and high resolution satellite sensors such as NOAA AVHRR, ERS ATSR, IRS-1C LISS, Landsat TM and SPOT HRV. The scenes contain spectral information that enables the land cover types, the vegetation types and status as well as the radiant surface temperatures to be mapped. Satellite-based land surface roughness maps are derived from classification analysis into land cover classes and combined with meteorological observations on roughness in each of the relevant classes. For ocean studies of phytoplankton concentration and alga blooms, the SeaWiFS satellite data are useful. Scatterometer data provide maps of the ocean wind speed and wind direction at low resolution operationally. The empirical scatterometer algorithms are used also for radar satellite data to retrieve high-resolution (400 m pixel) maps of the off-shore wind speed. The wind speed maps from ERS SAR satellite data are being validated with off-shore and coastal meteorological observation. Satellite-based wind speed maps may be used for future offshore wind power prediction.

<sup>2</sup> Hasager, C.B. and Jensen, N.O. 1999 Surface-flux aggregation in heterogeneous terrain. *Quarterly Journal of the Royall Meteorological Society*, **125**:2075-2102

#### 4.6 A simple model for the boundary-layer height and its application

*Sven-Erik Gryning and Ekaterina Batchvarova*

The mixing in the atmospheric boundary layer is limited upwards by a temperature inversion and decrease of turbulence, acting as top of the boundary layer. It is called the mixing or boundary-layer height. Because the top of the boundary layer to a high degree acts as a lid, its height is an important parameter in many practical applications such as the prediction of pollutant concentration and its removal by dry deposition, environmental monitoring, forecasting of surface temperature and scaling profiles of atmospheric turbulence. Over the sea it is one of the parameters that controls the water content in the atmosphere and consequently feed back on evaporation from the sea surface.

A simple model that describes the development of internal boundary layers and the growth of the daytime mixing layer was proposed. The model can be applied in a very simple met-processor model over homogeneous terrain. The model is also applicable over complex terrain. It runs on a PC. With a grid resolution of 0.5 km the models runs easily on a 200 km model domain.

In the model formulation it is assumed that the air is well mixed in temperature within the boundary layer and is capped by a infinitesimally thin entrainment layer, a so-called slab model. The model takes into account the main physical processes that govern the development of the atmospheric boundary layer, being mechanically and thermally generated turbulent kinetic energy within the layer, entrainment and subsidence aloft, and in coastal and other types of inhomogeneous areas mesoscale advection through the layer.

The model has been successfully validated in a large range of conditions. It has been used to simulate the development of the internal boundary layer over Athens, Greece during sea-breeze conditions, over Vancouver (Lower Fraser Valley), Canada and at the Swedish coast. It is presently used in an investigation of structure of the boundary layer over Kuala Lumpur in Malaysia, and in a study of the internal boundary layer over the Baltic Sea. Figure 1 shows an example of a simulation of the boundary layer over Vancouver, Canada.

A novel application of the model is connected to the problem of aggregating fluxes over inhomogeneous terrain. The mixed layer grows in response to the regional fluxes including aggregation of small-scale processes. When knowing the evolution of the boundary-layer height, the model can be solved for the (aggregated) heat flux. The required information on the evolution of the boundary layer for use of the method can be derived from wind speed and temperature profiles obtained from radio soundings. Alternatively data from remote sensing systems technique, like combined wind profiler and radio acoustic sounding systems, can be used. Applications over the NOPEX area near Uppsala, Sweden, Sodankylä in Finnish Lapland and Lindenberg in Germany suggest that the tile approach is a feasible concept for heat flux averaging in typical European agricultural-forest-lake landscapes.

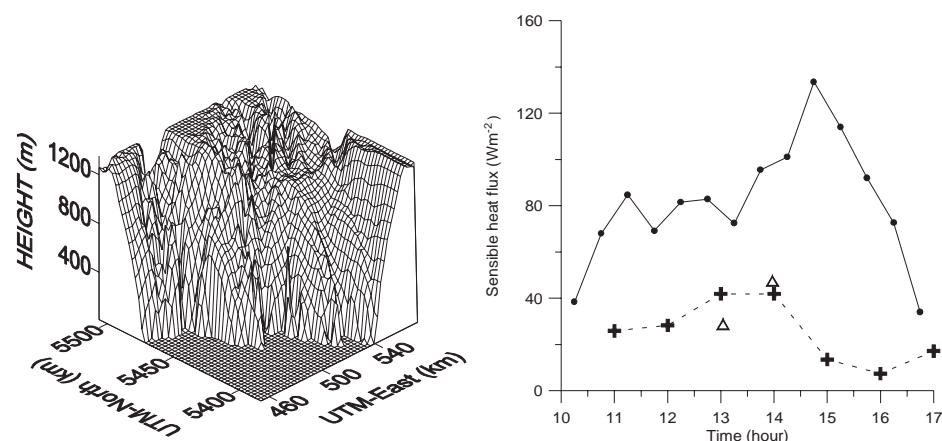

Figure 1 The left panel shows a perspective view of the modelled internal boundary layer height (1400 PST, 5 August 1993) over the Lower Fraser Valley, Canada. The right panel shows measured local sensible heat flux over the forest at the Sodankylä Meteorological Observatory in Finnish Lapland (• connected by a full line), the derived regional (aggregated) sensible heat flux (+ connected by a broken line), and flight-track mean values (Δ) from air craft measurements (14 March 1997).

## 5 Electric Design and Control

*Peter Hauge Madsen*

### **Objective**

The purpose of the research programme is to contribute with new knowledge and computational models for analysis and development of wind turbines with respect to electric and control characteristics as well as grid integration. The aim is to develop new control methods and principles, to optimise the application of electrical machines and power electronics and to improve the wind turbine influence on power quality. Finally, to develop concepts and methods for electrical integration of wind turbines in centralised and decentralised power systems in order to increase their energy production and capacity values.

### **Medium term goals**

Through a long-term strategic and applied research and development effort directed towards control principles for the operation and application of wind turbines, their electromechanical components and integration in power systems, to:

- Develop new control concepts for optimisation of wind turbine loads, production and power quality;
- Assess and test applications of alternative electromechanical components for wind turbines including new advanced generators and power electronics;
- Develop methods and concepts for electrical integration of large shares of renewable energy, especially wind energy, in centralised and decentralised energy systems.

### **Developments and results 1999-2000**

In order to develop the research programme to support the industry and the power utility sector with research of high quality and relevance in an internationally competitive manner, a strategic alliance has been formed in May 2000 with Aalborg University, Institute of Energy Technology. The alliance aims to strengthen the programme, both scientifically and with respect to qualified staff resources, in order to meet the research challenges with respect to a rapid international development of power electronics, electromechanical components and methods for control and regulation. The joint programme has developed satisfactorily, and the first joint projects have been implemented in collaboration with industry and power companies.

### **Control and power electronics**

Active control of wind turbines with induction generators connected to the grid through full-scale static frequency converters have been investigated in projects with both a pitch-controlled and a stall-controlled wind turbine type. The projects have demonstrated that loads can be reduced, control of the reactive power flow, improved power limitation and reduced flicker limitation. A patent on the control strategy has been applied for. In 2000 a survey of generator concepts and power electronic topologies for wind turbines has been carried out to support the industry's design considerations and form the basis for future R&D.

### **Grid integration**

The influence on grid power quality from wind turbines installed in weak grids or in large number is of high importance. We have contributed to international standardisation in IEC of power quality requirements and measurement and test procedures for wind turbines, and a draft document is now available. Wind farms connected to weak rural grids have been studied in India, where both the influences of wind farms on power quality as well as the influence from the grid on the wind turbines have been assessed. In 2000 a project started on the development of models for wind farms and their interaction with power systems in order to support the development of wind farms with improved power plant characteristics such as control capability, influence on grid stability and power quality. The 12 MW wind farm in Hageholm is modelled and the model verified for normal operation conditions.

## 5.1 Advanced control of wind turbines

Lars Henrik Hansen and Henrik Bindner

There is currently a strong drive to lower the cost of wind turbines by reducing the amount of material used. Also, the power system operators require an easier integration of the wind turbines into the power system. There is also a trend towards automatic adaptation to local conditions and to ensure that the wind turbine is not operating in conditions that will consume a large amount of the life time of the components or with components that are beginning to fail. Active control can play a very important role in all these issues in order to achieve the goals in a cost effective way.

In 1999 and 2000 Risø has been involved in two similar projects with wind turbines applying induction generators connected to the grid through a full scale static frequency converter. In the first project a pitched controlled wind turbine was used and in the other the wind turbine was a fixed pitch stall controlled type. Both the projects established full scale prototypes in order to verify the theoretical work

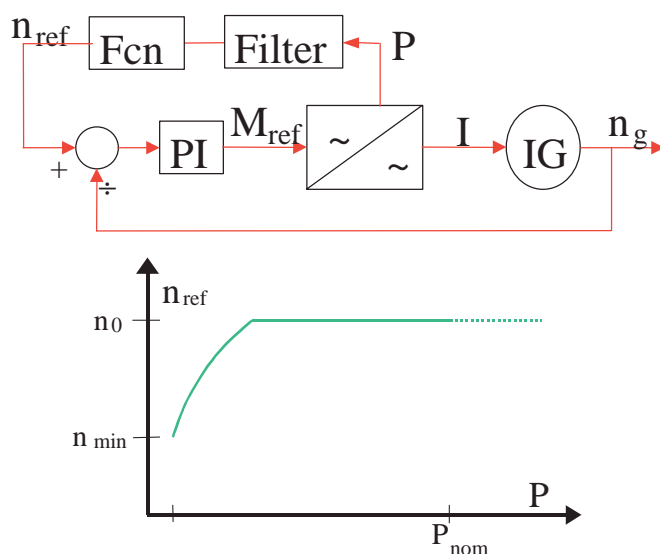

Figure 1 A model reference control strategy for variable speed. Above is the control loop with the feedback of the produced power in order to set the rotational speed of the turbine according to the graph below.

This relationship is then used to control the actual rotational speed of the wind turbine in a closed loop control scheme as shown in the upper part in the figure. This will optimise the power production at low wind speeds and limit the power at high wind speeds.

The perspectives of advanced control are many. It can be used to further control the loads on the wind turbine. It can be used to adapt the wind turbine to the actual operating conditions and through advanced condition monitoring to implement preventive maintenance and other measures to improve the availability and reduce maintenance cost. In order to obtain this the inclusion of the features and possibilities that comes by applying active control and condition monitoring has to be included in the wind turbine design from scratch in a concurrent design procedure that includes aerodynamics, structural dynamics and controls in a common framework.

Partners: Vestas, ABB Energi, NEG Micon, Siemens, Elkraft.

- [1] B. Wortman & L.H. Hansen, Multi-pole generator wind energy converter. January 2000, NEG Micon, Denmark
- [2] H. Bindner & A. Hansen, Double Controlled Wind Turbine: Comparison between pitch controlled wind turbine and pitch controlled wind turbine with variable speed (in Danish). Risø-R-1072(DA), Risø, Roskilde December 1998

The results of the projects show that loads can be reduced when compared to directly grid connected wind turbines. The loads include gearbox loads, peak loads in the drive train and load fluctuations especially at 3 times the rotational speed. This is obtained through the decoupling of the rotational speed of the generator from the grid frequency. The torque is then controlled on the generator shaft and the wind turbine rotor acts as a short term energy storage that is used to filter the power fluctuations of the wind input to the grid and to reduce the peak torque on the gear box. Another very important improvement is the power quality improvement. This includes control of the reactive power flow, improved maximum power limitation and reduced flicker emission. This is obtained because of the self-commutated inverter on the grid side of the frequency converter.

As an output of one of the projects a patent concerning the control strategy has been applied for. The main principle is shown in Figure 1. Based on the aerodynamics the optimal relationship between power and rotational speed is

## 5.2 Simulation of wind power plants

*Poul Sørensen*

The objective of this activity is to develop models for wind farms and their interaction with the power systems. The application of the models is intended to support the development of wind farms with improved power plant characteristics such as control capabilities and influence on stability and power quality. Besides, the models are intended to provide documentation for wind farms and their interaction with the power system.

The background for installation of wind turbines in power systems has developed rapidly through the last 20 years. Therefore, wind energy is becoming a significant part of the power supply, which strongly influences the dynamic behaviour of the power systems. E.g. in Denmark, more than 10 % of the electricity is already supplied by wind power, and the targets in the Danish Government's Action Plan "Energy 21" is to reach 50 % by 2030.

As a first step of developing models for wind farms, the 12 MW wind farm in Hagesholm is modelled in the EFP 2000 project "Simulation of wind power plants". The wind farm in Hagesholm consists of six 2MW NEG-Micon wind turbines with active stall control. The project is accomplished with Aalborg University and Dancontrol Engineering A/S as partners, and in a close co-operation with the utility NVE who owns three of the wind turbines. A simplified single line diagram of the model is shown below.

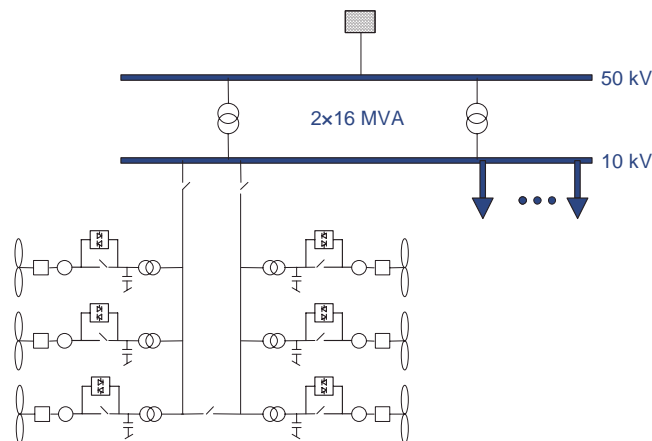

The grid model consists of standard components for external grid, substation bus bars and transformers, and lines to the wind turbines. The wind turbines are electrically modelled with transformers, shunt capacitors, soft starters and induction generators. Besides the electrical components, the wind turbine models also include mechanical models for the drive trains, aero-dynamical models and wind models.

All of the six wind turbines are modelled independently, which ensures that the interaction between the wind turbines is also included in the model. The individual wind turbine models also makes it possible to use models for the wind speed variations in the wind farm as input to the simulations.

In the EFP-2000 project, the model will be verified against electrical measurements on a single wind turbine and in the substation during normal operation conditions. The measurements and simulations will be used as input to power quality calculation tools, and the simulated power quality will be compared to the measured.

The verification of the models during normal operation conditions provides a good basis for the model development. However, to use the models to simulate transient stability connected to grid faults will require further verification of the models, using measurements of transient events, which are comparable to grid faults in the effect. The strongest transient event in normal operation conditions is the switching of a wind turbine to the grid, and switching between generator speeds.

Partners: Aalborg University, Dancontrol Engineering A/S and NVE. Sponsor: Danish Energy Agency 1363/00-0003 (NVE participation not sponsored).

### 5.3 Power quality

*Poul Sørensen*

The general objective of the power quality activities is to study and demonstrate how to quantify, measure and improve the impact of wind turbines on the power quality of the grids, where the wind turbines are connected. The background for the power quality activities is that wind turbines are often connected to distribution systems in rural areas. The grids in these rural areas are typically weak, as they are designed to distribute a relatively small power to the customers connected to the distribution grid. Tools to analyse the influence of wind turbines on the power quality help the distribution system utilities to design the grid connection of wind turbines at a minimum of costs for grid reinforcement, and at the same time ensure sufficient power quality for the other customers.

An important power quality activity is the work with international standardisation. Traditionally, power quality requirements for grid connection of wind turbines have been based on national standards, not only for requirements but also for the measurement and test procedures for the wind turbines. Risø has participated in the IEC working group IEC/TC88/WG10, which has now prepared a CDV (Committee Draft for Voting) of a standard IEC 61400 "Measurement and assessment of power quality of grid connected wind turbines". This document is an important step to obtain an agreed international definition on power quality characteristics of wind turbines, including specification of measurement procedures and a description on, how these characteristics can be used to assess the influence of one or more wind turbines on the power quality.

Another activity is the EFP 98 project "Power quality and integration of wind farms in weak grids". In this project, the power quality is studied in India, where large wind farms are connected to very weak grids. Both the influence of the wind farms on the power quality and the influence of the power quality on the wind turbines have been studied in this project.

Concerning influence of wind turbines on power quality, the focus in India is on reactive power consumption. Reactive power consumption is already high in the rural regions due to agricultural pumping with uncompensated induction machines. The wind turbines with directly connected induction generators add to that consumption. Power quality measurements done in the project has shown that the capacitors for reactive power compensation are not working in approximately half of the wind turbines in the Lamba region in Gujarat state, whereas in the Muppandal region in Tamil Nadu state, the majority of the capacitors work. This is an interesting result, especially as there are no incentives in Gujarat for maintaining the capacitor banks, whereas wind turbine owners pay for reactive power in Tamil Nadu.

The power quality in India also has a significant effect on the operation and lifetime of the wind turbines. Outages, excessive voltages and voltage unbalance cause the wind turbines to trip. Moreover, the frequency variations strongly influence the performance of the stall controlled wind turbines. The left graph below shows how the frequency varies during the day between 48 and 51 Hz. The consequence of this variation is illustrated in the power curves to the right, showing that the maximum point of the 51 Hz power curve is almost 20 % higher than the maximum of the 48 Hz power curve.

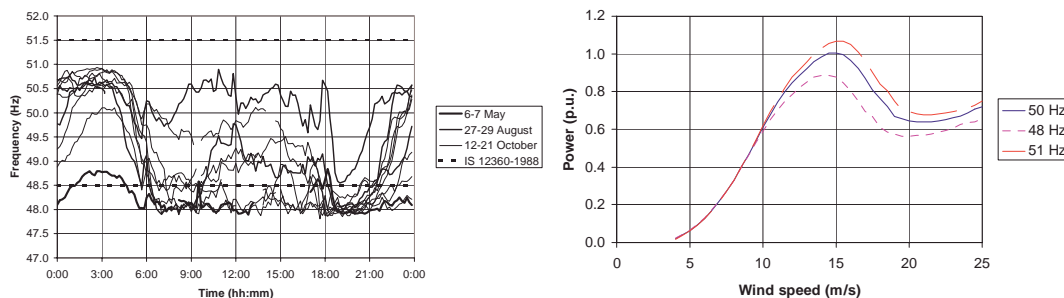

Partners: DEFU (Danish Utilities Research Institute) and ER&DCI(T) (Electronic Research and Development Institute of India). Sponsor: Danish Energy Agency 1363/98-0024 and the Indian Ministry of Non-Conventional Energy Sources (MNES) ref: 52/164/97/WE/PG dated 7/10/98



## 6 Wind Power Meteorology

*Lars Landberg*

### **Purpose**

To contribute with new knowledge on wind climatology, atmospheric flow and turbulence as a basis for development and application of methods and models to predict wind resources as well as wind loads on wind turbines and structures in all kinds of natural terrain.

### **Medium-term goals**

Through a long-term research effort within boundary-layer meteorology including wind climatology, atmospheric flow on meso- and micro scale, atmospheric turbulence and experimental meteorology to

- further develop models and to extend the area of geographical application of the wind atlas method for wind resource studies and models for short-term prediction of wind farm production;
- develop and combine the wind atlas method and models for atmospheric turbulence and extreme events with regard to wind load calculations and an estimation of extreme wind conditions in natural terrain;
- develop models for off-shore wind flow including resources and extreme winds and to support these models by measurements.

### **Selected results 1999-2000**

- WAsP version 6.0 launched in 1999 and 7.0 in 2000;
- Wind Atlas for Egypt and Wind Atlas for Russia published;
- Short-term prediction models implemented or to be implemented in: Denmark, Germany, Ireland, Spain, USA;
- The KAMM/WAsP wind resource estimation method finished;
- Models in WAsP Engineering verified (planned launch in 2001);
- A total re-instrumentation of off-shore masts, (Omø, Gedser Rev and Rødsand), improved data recovery rate;
- Development of a 2D IBL model, with stability change, to determine changes of the wind speed profile with regard to fetch.

### **Web-sites**

- [www.wasp.dk](http://www.wasp.dk): the home of the WAsP program;
- [www.windatlas.dk](http://www.windatlas.dk): information about the European Wind Atlas and the wind atlas methodology;
- [www.prediktor.dk](http://www.prediktor.dk): the home of the Prediktor forecasting system;
- [www.waspenengineering.dk](http://www.waspenengineering.dk): the home of the WAsP Engineering program and project;
- [www.cleverfarm.com.de](http://www.cleverfarm.com.de): the home of the CleverFarm system and project;
- [www.mesoscale.dk](http://www.mesoscale.dk): information about meso-scale modelling and research and the KAMM/WAsP method.

## 6.1 Wind Atlas Analysis and Application Program (WAsP)

*Niels Gylling Mortensen, Lars Landberg, Ole Rathmann, Helmut P. Frank, Ib Troen, Erik L. Petersen*

### Introduction

The WAsP project is synonymous with a suite of software programs intended for wind data analysis, map editing and digitisation, wind atlas generation, wind climate estimation, power production prediction, micro-siting of wind turbines, wind farm production calculations, wind farm efficiency evaluation as well as wind climate and wind resource mapping. WAsP is then essentially a software implementation of much of the knowledge and research efforts of Risø's Wind Energy and Atmospheric Physics Department within the discipline of wind power meteorology. The project furthermore includes software support, courses, training, consultancy work and second opinion studies.

### Project development

The WAsP project is the longest ongoing project in the Wind Power Meteorology Programme. The purpose of the project is to make the wind atlas methodology used for the European Wind Atlas generally available, as a collection of models and engineering software tools. The project began formally in 1987 with the launch of the first version of the software. Since then, WAsP has gained widespread recognition as the industry-standard tool for wind resource assessment and estimation of the power production from single wind turbines and wind farms. The WAsP methodology has been applied by about 650 institutions and companies in more than 70 countries all over the world; for wind resource assessment on a national, regional and local scale.

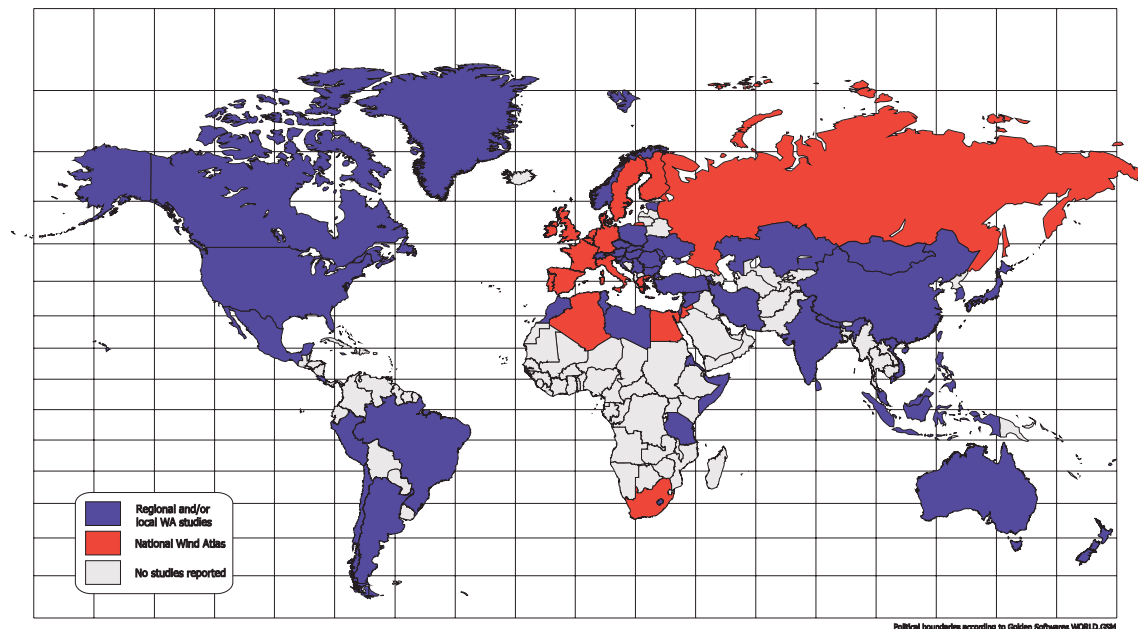

### Present status

A Windows version of WAsP was released in March of 1999; more than half of the users now have a license for this version. In addition, more than 125 users have acquired a licence for the WAsP Utility Programs. In 1999-2000, WAsP courses and training sessions were held in Denmark, Poland, the Czech Republic, Spain, Egypt, South Africa and Japan. These courses and training activities, as well as the WAsP software support and hot line, probably represent one of the most comprehensive educational efforts of a research program or research institution anywhere in the world. The methodology is continuously being developed and a detailed and verified Wind Resource Atlas for Denmark was published on CD-ROM in 1999.

The WAsP team may be contacted through [wasp@risoe.dk](mailto:wasp@risoe.dk) (general information, sales support, shipping and invoicing), [wasp.support@risoe.dk](mailto:wasp.support@risoe.dk) (technical support), or [wasp.licence@risoe.dk](mailto:wasp.licence@risoe.dk) (licence applications). The home page for the WAsP project is [www.WAsP.dk](http://www.WAsP.dk).

## 6.2 WAsP engineering

Jakob Mann

WAsP Engineering is measurements, analysis and theories concerning properties of the wind which are relevant for the estimation of loads on wind turbines and other civil engineering structures situated in all types of terrain. The project and its currently running continuation are funded by EFP. Most of the results of these activities are unified in the computer program called WAsP Engineering, version 1 Prototype.

The wind properties treated in the computer program are:

- Extreme wind speeds, e.g. the 50 year wind. If a wind turbine is well situated on a hill the mean wind speed and thereby the energy production can be increased significantly compared to that over flat terrain. Unfortunately, the 50 year wind will increase correspondingly, maybe calling for increased strength of the wings or other parts of the turbine;
- Wind shears and wind profiles. Strong mean wind shears (large differences of the mean wind speed over the rotor) give large fluctuating loads and consequently fatigue on wind turbine blades, because the blades move through areas of varying wind speed;
- Turbulence (gusts of all sizes and shapes) causes dynamic loads on various civil engineering structures, including wind turbines. The strength of the turbulence varies from place to place. Over land the turbulence is more intense than over the sea. Also hills affect the structure of turbulence. We model various terrain dependent properties of turbulence.

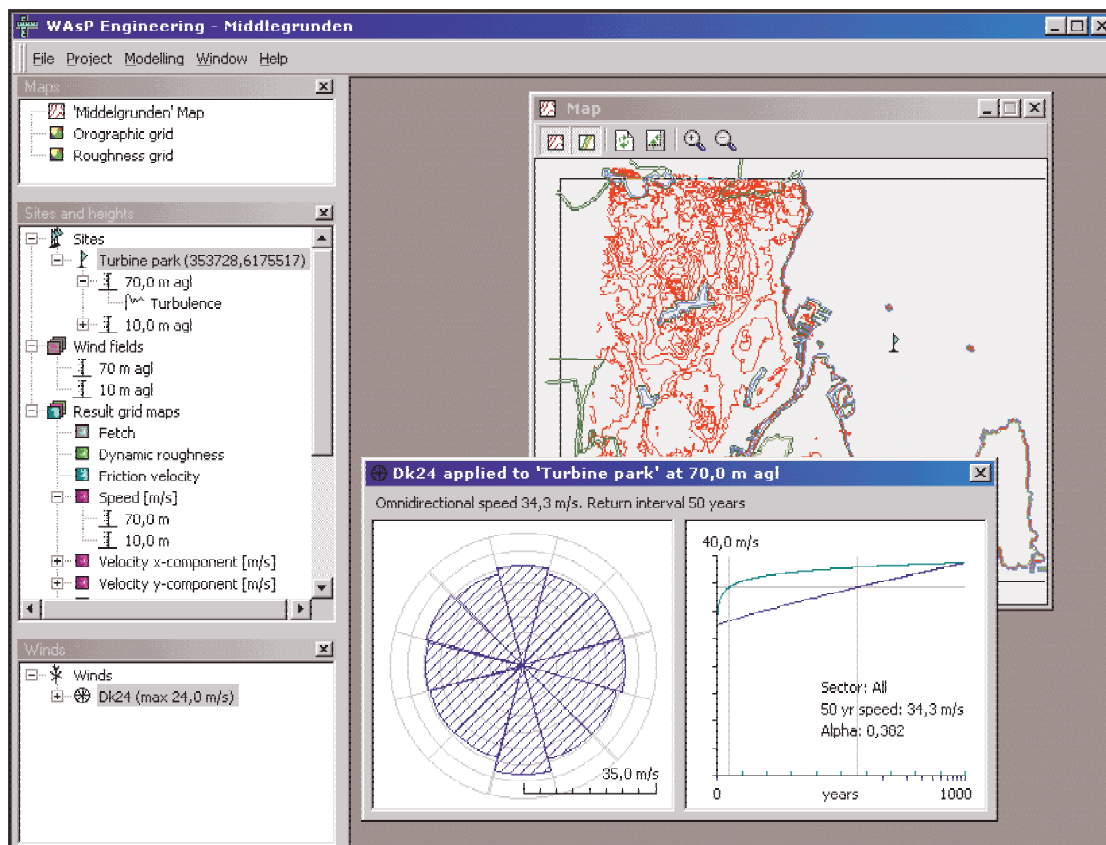

Figure 1 The graphical user interface of WAsP Engineering prototype showing a calculation of the extreme wind climate at the Middlegrunden wind turbine park off the shore of Copenhagen.

### 6.3 Short-term prediction

Lars Landberg and Gregor Giebel

#### Introduction

It is well known that the wind is a highly volatile resource. Significant changes are found on time-scales of less than a few hours. To fully benefit from a large fraction of wind energy in an electrical grid, it is therefore necessary to know in advance the electricity production generated by the wind. To be of use to utilities a prediction window of up to two days is required. This will enable the utility to control the conventionally fuelled plants in such a way that fossil fuel will in fact be saved. Furthermore, this will enable the utility to trade wind-power-produced electricity. With the abilities of present day numerical weather prediction (NWP) models it is now possible to accomplish the aforementioned task; this has been shown in several studies.

#### Project development

Since 1990 Risø has been developing models and systems for short-term prediction. In the beginning off-line (i.e. basically research tools) were developed, but due to the interest from the electric utilities on-line systems were developed. The on-line systems are automated running on the Internet. The idea is to use physical models to as great an extent as possible. This is done such that the large-scale flow is modelled by a Numerical Weather Prediction model, here HIRLAM; as we zoom in on the site - using the geostrophic drag law and the logarithmic wind profile - more and more detail is required, this detail is provided by the WASP program. To calculate the power production of the wind farm and to take the shadowing effects of turbines into account, the PARK program is used. Finally, to take any effects not modelled by the physical model and general errors of the method into account, a model output statistics (MOS) module is used. An example of the models ability to predict storms accurately is given below.

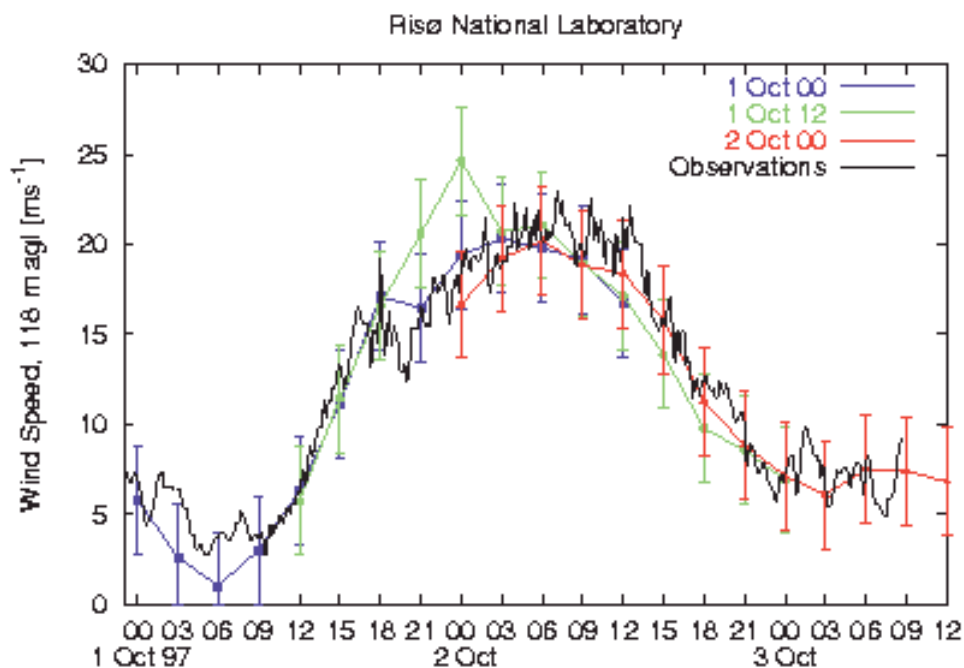

#### Present status

Two things are happening now: one is the commercialisation of the model described above, and the other is a further development of the models. Offering the Prediktor ([www.prediktor.dk](http://www.prediktor.dk)) system on commercial terms does the commercialisation. Presently, Prediktor has been sold to Spain, Ireland and two places in the US. The further development line is a project, where Risø in co-operation with IMM (Institute of Mathematical Modelling) at the Danish Technical University are developing a new model, Zephyr. This model combines the mainly physical model of Risø with the mainly statistical model of IMM.

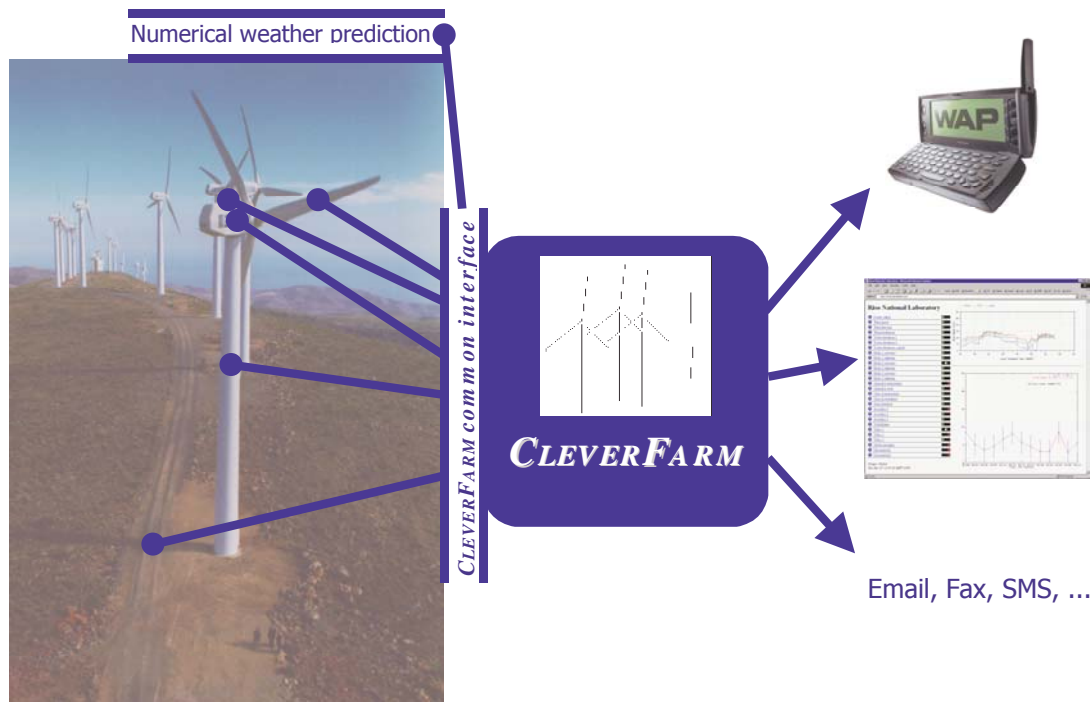

*The idea of CleverFarm: Measurements of turbine and wind parameters and control of the wind farm can be effected via the internet, using clever new control algorithms.*

#### 6.4 CleverFarm

*Gregor Giebel and Lars Landberg*

The large success of wind energy has led to a large grid penetration in some areas of Europe. In these areas, the prime sites for turbines with a high resource and good accessibility are often already used for wind energy generation. This means that new turbines are to be built in more remote areas or offshore. These sites are by their nature less accessible than most of the turbine sites so far. This leads to new challenges in the monitoring, remote control and fault prediction of the machinery.

The EU-funded project CleverFarm tries to address some of the issues involved, such as a common interface for data from wind farms, raising an alarm in the case of an emergency. It tries to use the previously disjoint measurements for better fault prediction, and to give operators and maintenance personnel on-line access to the status of the wind farm. Additionally, the value of the generated electricity will be improved by implementing short-term predictions of the power output on a scale of 0-48 hours (and potentially more) in advance using Risø's Prediktor forecasting system. The goal of the project is to prepare a modular platform for the integration of various data sources into one common interface.

The CleverFarm system would comprise controllable video cameras, also giving access to the noise levels and audio signature. Measurements of grid power quality and lightning strikes will be integrated, together with corrosion and gearbox oil analyses (when available). The simultaneous availability of all these measurements could be used for automatic condition monitoring for preventive maintenance. Ideally, the remaining lifetime of single components should be predicted. At the very least, some ways of fault prediction should be available. In that event, the wind farm calls the maintenance crew due to the imminent fault in a major subsystem of the turbine. Using the weather prediction module it also could give a prediction of the accessibility and expected weather for the next days. The cost saving potential for maintenance is quite large – one just has to think of the costs involved in not having the right spare part on the boat (or helicopter) for far offshore servicing.

The project has started in April 2000. The first implementation should be ready for testing in summer 2001. The final version is expected during 2003.

## 6.5 Measurements and modelling of offshore wind

Rebecca Barthelmie

### Introduction

Benefits of locating wind farms offshore include lower turbulence, greater persistence of winds and higher wind resources. To quantify these effects, and hence to support development and planning of offshore wind farms in Denmark, meteorological measurements at the prospective sites at Gedser Rev, Rødsand, Omø Stålgrunde and Middelgrunden are continuing together with ongoing measurements at Vindeby and a land-based mast at Gedser. This database is proving an invaluable resource in a number of related projects including assessment of wind-wave interactions, analysis of the storm of December 1999, Prediction of Offshore Wind Energy Resources (POWER) and in a new project aimed at evaluating and improving offshore wake models (ENDOW).

### Project development

During 1999, Rødsand, Gedser Rev and Omø Stålgrunde were re-instrumented using satellite-linked Aanderaa systems increasing data recovery to over 95%. An overhaul of the wave monitor at Rødsand was also undertaken together with detailed analysis of the wave database.

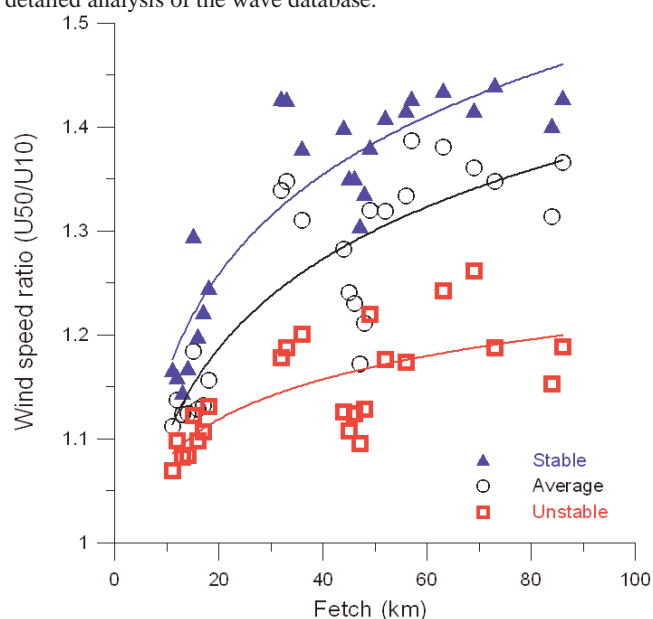

The figure illustrates the variation of the ratio of wind speeds at 50m height at Rødsand to those at 10 m with fetch (distance to the coast) in three stability classes. In stable conditions the ratio comes to equilibrium over longer distances (approximately 50 km) than in unstable conditions.

In addition to comprehensive wind resource assessment at Rødsand and Middelgrunden, the data have been analysed to illustrate the impact of stability on the offshore wind profiles and wind speed distributions. These findings are supported by development of the Coastal Discontinuity Model which is being linked to the WAsP model to predict offshore wind resources in coastal regions of Europe. There is evidence that the mean (scale) and variance or form (shape) of the wind speed distribution are modified at different rates as flow moves offshore. This indicates that the descriptive parameters of wind speed distributions from offshore locations may substantially differ from those at onshore locations and hence that adjustments for stability are necessary when interpolating wind speed climatologies offshore. Data from the Danish offshore monitoring program have also been used to investigate the persistence of flow in the coastal zone. The results indicate the temporal auto-correlation of wind speeds measured at, or above, 40 m in the offshore near-coastal zone is not significantly higher than that from land sites. However, the persistence of wind speeds above typical turbine cut-in speeds is higher at sites over water surfaces. These results are being extended to quantify the frequency distributions of electricity generation at prospective wind farm development sites in Denmark.

### Acknowledgements

These projects are supported by the European Commission Fifth Framework Non-Nuclear Energy and Joule Programs and SEAS/Elkraft.

## 7 Wind Turbines

*Peter Hjulær Jensen*

### **Objective**

The objective is to contribute to achieve a more reliable basis for development and utilisation of wind turbine technology and to support the energy politic objectives for an increased international application of Danish wind turbine technology. Among the initiatives are development of new knowledge and methods to verify loads and safety for wind turbines, experimental verification of the strength of wind turbine components, new components for wind turbines, methods to assess the technical and economic consequences of investing in different wind turbine applications and new opportunities with regard to electric grids and hybrid energy systems.

### **Mid-term goals**

Through a long-term strategic and applied research and development effort within the scientific areas loads and safety, structural design and verification as well as application and integration of wind turbines in the energy systems, to:

1. Develop new and more realistic assumptions for the load and safety design of WT, technical requirements for design of WT, site studies and evaluation, certification and standardisation;
2. Develop new methods for establishing the background for decisions to increase the use of centralised and decentralised energy systems (large-scale integration and hybrid energy systems);
3. Develop and establish methods to technical/economic modeling/estimations/assessment of the development in the wind turbine field;
4. Develop new methods for experimental determination of wind turbine characteristics and their components, including testing methods for industrial application;
5. Conduct test-station tasks for the Danish Energy Council.

### **Selected results from 1999-2000**

1. Establishment of an offshore wind farm research project in co-operation with the electric utilities as to establish the design basis for offshore wind farms and in the project to develop the technical tender documents for The Electric Utilities first off shore call for tender;
2. Development of calibration methods for partial coefficients related to design of offshore wind farms;
3. Testing of prototype laser instrument;
4. Development of methods for structural modeling of wind-turbine blades;
5. Development of a model to calculate the technical/economic lifetime of a wind turbine;
6. Start of project to verify the site-calibration method in connection with "performance measurements";
7. Formulation of a proposal for standard measurements of the energy output in wind farms;
8. Start development of a method to determine modal shapes for wind turbine blades;
9. Start of project to evaluate Doppler SODAR in preparation for performance and load measurements of wind turbines on land and sea (this activity is now in Wind Turbine Diagnostics, c.f. p. 34);
10. Start of project to optimise cup anemometers for wind energy application (this activity is now in Wind Turbine Diagnostics, c.f. p. 34);
11. Issue a revised recommendation for The Technical basis for the Danish Approval System for Wind Turbines.

WEP-sites:

Design basis for offshore wind turbines: <http://www.risoe.dk/vea/offdes>

The Danish Approval System for Wind Turbines: <http://www.vindmoellegodkendelse.dk/>

Guidelines for design of wind turbines: <http://www.risoe.dk/vea-dnv>

## 7.1 Contract with the Danish Energy Agency

*Egon T.D. Bjerregaard*

Under a standing agreement with the Danish Energy Agency (DEA) the department enters a yearly contract describing the activities with work plan, budgets and goals for the coming 1-year period. The general purpose of the standing agreement is to support the department in maintaining its' status as the national knowledge centre in the field of wind energy, and to assist DEA in managing the Danish Approval Scheme for Wind Turbines.

The activities and services carried out under each 1-year contract are planned and followed up in close co-operation with DEA. At the end of each plan period a report is presented to DEA describing the activities and the achieved results.

Each years activities are described in sub items under the following three main items, which are kept the same from year to year for the sake of continuity:

- Knowledge centre for wind energy;
- Approval Scheme for Wind Turbines;
- Test methods for type approval of wind turbines.

1999: Budget 7.5 million DKK. For 1999 the activities was defined in 14 sub programmes under the above mentioned main groups. A significant part of the knowledge centre activities has been devoted to information and knowledge building and to international standardisation which is regarded as a main area of activity under the contract. Specialists from Risø have participated in different groups and committees under IEC and CENELEC. This work is an ongoing long-term process. The resulting standards are important for the industry and also for the development of the Danish Approval Scheme for Wind Turbines. A new set of rules for approval of small wind turbines have been completed in 1999, and work has been initiated on the revision of "Teknisk Grundlag" and some of the recommendations that form the documents for the type approval.

Preparatory work has been carried out for a new test site in Jutland for testing of large wind turbines. Also some of the resources have been devoted to development of methods and equipment for testing of large rotor blades.

2000: Budget 6.35 million DKK. For the year 2000 the activities have been defined in 15 sub programmes which only differ slightly in content from 1999. From the list of activities can be mentioned the continuing work with international standardisation and the work related to the Approval Scheme for Wind Turbines. A new technical criterion for approval of wind turbines has been completed and issued both in Danish and English. A recommendation for generators to wind turbines and a preliminary recommendation for approval of offshore wind farms has been issued. Committees dealing with design and testing of rotor blades and implementation of IEC standards in the Danish approval scheme have been established and are planned to complete the work in 2001. Also a committee dealing with gear box approval has been established and is expected to continue the work in 2001. A number of international meetings have been carried out under the contract. Investigation and development of new test methods for measurements on wind turbines is being carried out. Information about the approval scheme can be found on the web site: [www.vindmoellegodkendelse.dk](http://www.vindmoellegodkendelse.dk)



## 7.2 Design basis for offshore wind turbines

Sten Frandsen

### Description

For the immediate future, 700 MW of offshore wind farms are planned for the relatively shallow waters around Denmark. In preparation of the first demonstration projects of each approx. 100 units it was proposed to conduct an investigation of the needs as to revision of the design basis for wind turbines and subsequently prepare such revision. The work comprised the following:

The existing Danish standard on loads and safety for wind turbines, DS 472, was critically reviewed. This included analyses of load cases, extension of “external conditions” to the offshore environment, specification of hydraulic conditions (waves, current and ice), safety level to be chosen, soil investigations, issues regarding operation and maintenance, risk of ship collision and increased turbulence in wind farms causing fatigue. At project mid-term, a recommendation for design of offshore wind turbines was issued in time to be applied in the tendering for the mentioned demonstration projects.

And further, resulting from the work, an amendment to the DS 472 regarding extreme wind speed, safety and wind farm turbulence was proposed and accepted by the standard committee. These immediate results of the project were adapted by the office for the Danish type approval system that further refined the document.

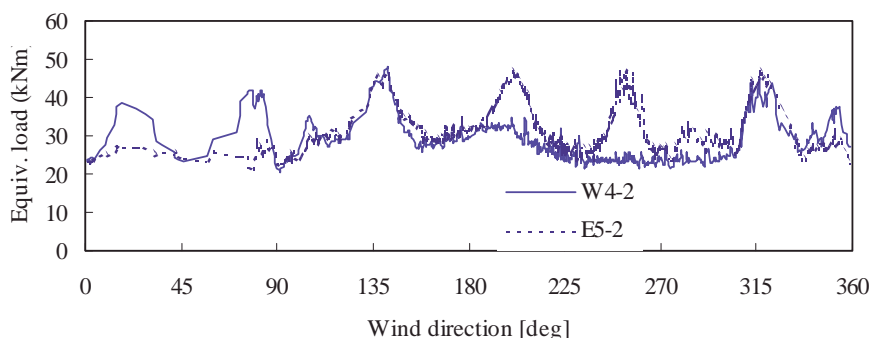

*In offshore wind farms fatigue loading generated by neighbouring wind turbines is a major problem that has to be dealt with. The fatigue-load measure “equivalent load” for two wind turbine units, 4W and 5E, is shown as function of wind direction,  $8 < U < 9$  m/s. It is seen that under wake conditions, the fatigue loading is nearly doubled. A model for the integrated fatigue loading in wind farms has been established and implemented in standards.*

After this initial effort, the project has focussed on the combination of wind load and hydraulic loads, the problem being that the partial safety factors of e.g. wind and wave loads are different, and a method for deduction of the integrated safety factor must therefore be devised.

Another issue, which is being dealt with, is the impact of very large wind farms on the local wind climate. For large wind farms, the wind speed will be reduced in the downstream end, possibly resulting in disappointing production. The project will not be able to produce explicit results, but merely to point to future experiments that can support theoretical considerations.

Results from the project are compiled and reported on the web-page: <http://www.risoe.dk/vea/offdes>.

Partners: SEAS, Elsamprojekt, Rambøll, Niras, DNV Sponsor: EFP-1999

### 7.3 Guidelines for Design of Wind Turbines

Morten Lybech Thøgersen and Knut Olav Ronold (Det Norske Veritas)

#### Description

The knowledge in wind turbine design gained within the last decades is immense and often only available in the form of scattered publications and various notes. The project ‘*Guidelines for the Design of Wind Turbines*’ was initiated in order to collect and compile this knowledge and present it in a clear and easily accessible publication.

The publication is produced through a co-operation between Risø National Laboratory and Det Norske Veritas, parties which are both involved in wind turbine certification. Thus, an important part of the guidelines is to outline current design requirements, which a new turbine must satisfy in order to achieve a type approval. The guidelines deal with methods for design of various structural and mechanical wind turbine components, and the relationship to current codes and design requirements is outlined. The guidelines are structured in a manner, which makes the material on a specific topic easily accessible. Useful introductions to each individual structural or mechanical component are included and form a valuable help to new and inexperienced designers. Examples of the content are listed below:

1. *Safety and Reliability*: A brief introduction to the probabilistic background for design codes and standards is given. An introduction to system safety and operation is also given, as well as methods for evaluation of the safety and reliability of a wind turbine and its components;
2. *External Conditions*: A description of the environmental impact wind, temperature, earthquakes and sea-waves is given. Basic formulae for representing the environmental loading are given. Guidelines for dealing with special stability issues, e.g. wind shear and transient wind conditions, are also given;
3. *Loads*: The calculation of design loads according to different design methods is specified. In particular, both simplified and advanced tools for calculation of extreme and fatigue wind loads are described. Special emphasis is laid on a practical approach to aeroelastic modelling. A brief description of hydrodynamic load types for offshore wind turbines is included;
4. *Yaw System*: A description of the design process, including: determination of design loads, description of yaw drive, yaw ring, yaw bearing etc.;
5. *Foundations*: Design methods for wind turbine foundations, including soil investigations, gravity, plate and pile foundations.

Other topics included in the guidelines are: Design of *rotor blades* and *hub*. Design of the *nacelle* including the main components such as main shaft, main bearings, main gear, couplings and generator. Design of *towers* and *electrical installations*.

Valuable references are included, with hyperlinks to electronic versions of the references when available. It is the intention that the guidelines are published as an interactive publication, where the references are available on-line, either from a CD-Rom or directly through the Internet. The audience for the ‘*Guidelines for Design of Wind Turbines*’ is intended to be new wind turbine engineers employed at the wind turbine manufacturers and at research institutions, and also students may find it useful. However, also experienced engineers may find valuable information in the guideline and may find it useful as a handy book of reference.

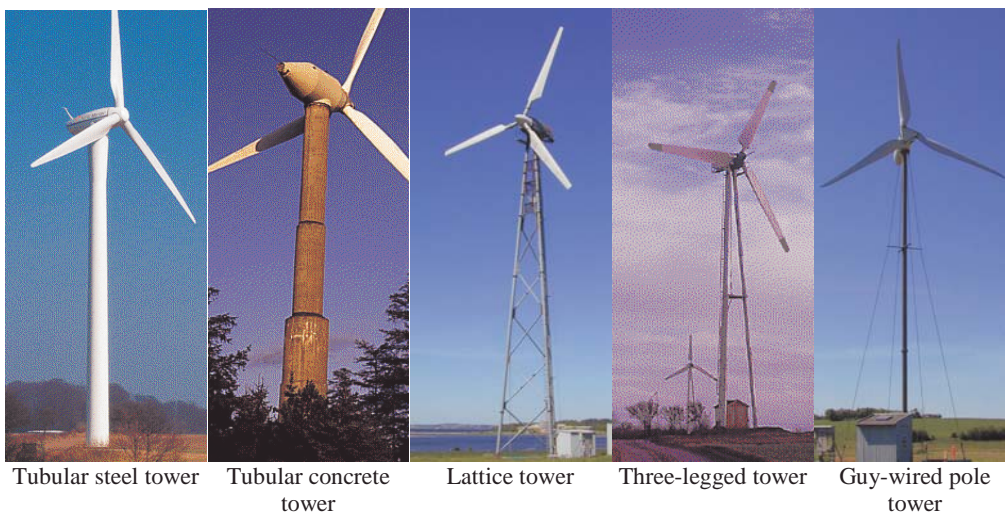

Illustration from the guideline pictures from [www.windpower.dk](http://www.windpower.dk) and by Risø.

## 8 Wind Turbine Diagnostics

*Jørgen Højstrup*

### **Objective**

Research based, internationally accredited testing of wind turbines in relation to certification, general documentation and support of the industrial development of wind turbines. The testing is generally performed as field testing on a commercial basis.

### **Mid-term goals**

Maintain or increase the high quality of the test measurements and at the same time perform cost optimisations to be able to do well in the ever increasing competition in this field. The medium-term goals are:

- To optimise the use of our technicians in field measurements. With the start of 2001 all of the technicians in the department that are involved in field measurements on wind turbines and in general boundary layer experiments will be available in one group, making it possible to use this part of the staff more efficiently, especially since there is a negative correlation between the timing of wind turbine measurements (generally high activity in autumn and winter with high wind speeds) and the boundary layer experiments (highest activity in spring and summer, where conditions for general field experiments tend to be more favourable);
- To start operation on the planned test station for MW sized wind turbines in the high-wind climate on the West Coast of Jutland (Høvsøre);
- Finalise development, test and document the new front end to our data acquisition system. A general front end to the measurement system has been developed, greatly simplifying the setting up and operations of the measurements, and at the same time increasing the reliability;
- Finalise development, test and document new software for the data acquisition system. The existing software which is highly specialised, lacks documentation and is DOS-based, and therefore it was decided to start developing new simpler WINDOWS based software founded on commercially available components;
- Obtain accreditation for the measurement of power quality;
- Obtain accreditation for general wind measurements.

### **Selected results 1999-2000** (programme initiated in 2000)

- Improved methods for the measurements of power performance in complex terrain. Using much more detailed measurements than usually available, uncertainties in measurements could be determined more accurately, and improvements suggested;
- Improved method for the inclusion of flow inhomogeneities into power curve measurements. The so-called site calibration that must be used because even in slightly complex terrain the wind speed at the measurement mast and at the turbine position can be significantly different, and would also be influenced by the atmospheric stability (heating/cooling of the ground);
- Design of optimised cup anemometer with emphasis on the properties necessary for high-quality wind energy measurements in different terrain types. Design considerations for the clarification of factors influencing the sensitivity of the cup anemometer to vertical components of the wind speed as well as the influence of turbulence;
- Evaluation of SODAR (acoustic radar) for the measurement of wind as a replacement for high towers. The SODAR could be an attractive alternative to expensive tall towers, but so far the comparisons available in the literature are insufficient in the sense that they demonstrate to which accuracy the SODAR can measure wind speeds when it works correctly, but the present study concentrated on also to identify the situations in which the instrument did not work with sufficient accuracy;
- Analysis of power performance of a stall regulated wind turbine in very cold climate and recommendations of subsequent adjustments of turbines. In climates with very large variations in temperature between summer and winter, special care must be taken such that the turbines are adjusted correctly to stay below the max. allowable power production in winter and at the same time not produce too little in the summer time. The unusual turbulence conditions associated with snow cover in the winter time was also shown to have a serious influence on the stall levels of the turbines.

## 8.1 High quality measurements

Troels Friis Pedersen

Wind farm developers and wind turbine manufacturers use power performance testing of wind turbines to document performance characteristics of wind turbine prototypes and wind farm installations for certification and warranty purposes. The present international standard for power performance testing is the IEC 61400-12, which is under revision these years. Some of the revision points in the standard concern measurement of wind speed. Field testing of cup anemometers in the CLASSCUP project has shown, see Figure 1, that there are systematic differences between different makes of cup anemometers of more than five percent for high turbulence conditions. This has a substantial influence on power curve measurement. Warranties are seen to be going to the one or the other side dependent on the type of wind speed sensor being used. There is therefore an urgent need to improve the accuracy of wind speed measurements.

Some of the problems of cup anemometer measurements are that the average measured wind speed is not well defined, and that cup anemometers behave very differently in turbulent wind than in a constant speed wind tunnel, where they are normally calibrated. The reasons for the differences, shown in Figure 1, are known to be due to both angular characteristics and dynamic over-speeding.

The CLASSCUP project is developing a classification system for cup anemometers that takes all known cup anemometer factors into account, and that can classify cup anemometers the same way as power transducers are classified in IEC standards. Some of the criteria for such a classification are to

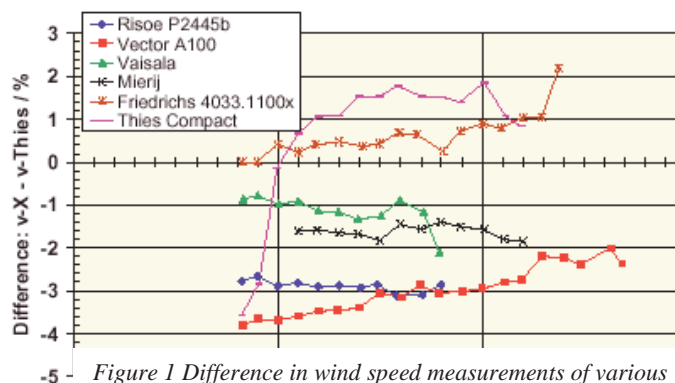

Figure 1 Difference in wind speed measurements of various cup anemometers compared to the Thies 4.3303.22.000 cup anemometer in flat terrain measured 8m above ground, from 1)

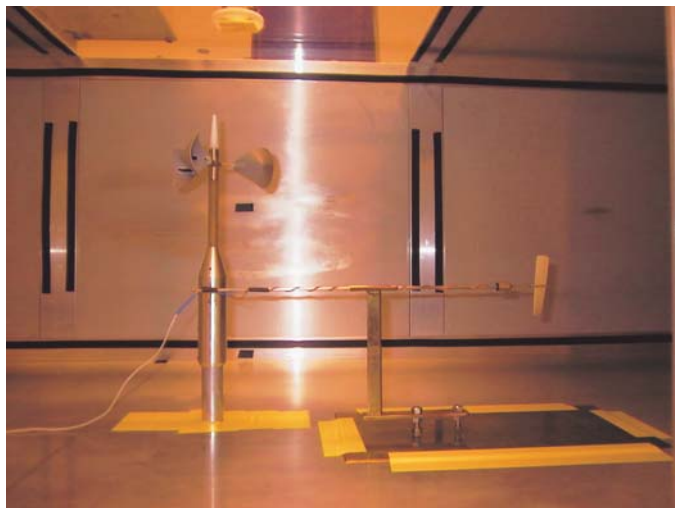

Figure 2 CLASSCUP anemometer being tested in the wind tunnel

define environmental conditions under which cup anemometers are normally operated. There seem to be two relevant classes, one for reasonably flat sites and one for complex sites with steep slopes. The CLASSCUP project is also aiming at producing an optimized design that within such a classification system has a class 0.5, which corresponds to only 0.5% systematic difference from the wind tunnel calibration. Such a design has been produced as a prototype, see Figure 2, which is being tested in the field in the autumn of this year.

The output of the CLASSCUP project, carried out by RISØ in co-operation with FFA in Sweden and DEWI in Germany, is being used to encourage new cup anemometer designs and to enhance the requirements of wind speed measurements directly in the revision of the IEC power performance standard.

1) Outdoor comparison of Cup Anemometers, A. Albers, H. Klug, D. Westermann, DEWEK 2000

## 8.2 Power curve measurements in complex terrain

*Ioannis Antoniou*

Measurements of power curves in flat terrain is quite straightforward and well documented in recommendations and standards, but a very large number of wind turbines are being erected in complex terrain, where the flat terrain methods only have very limited use. In the standards this is only covered informatively and only by a few sentences (e.g. [1], [2]). However for many wind energy projects, it is a contractual obligation to verify the warranted power curve of the turbine and it is important to establish methods to perform these measurements with a documented accuracy. One of the most important issues in complex terrain is that the wind must be measured at a different position than that of the turbine. The measured wind speed will be different from the wind at the position of the turbine because of terrain induced horizontal inhomogeneities and vertical distortion of the wind field. This issue is being resolved by making simultaneous measurements at the mast position and the turbine position before erection of the turbine, a so-called site calibration.

The objective of the project is to make power curve measurements on the same turbine in both flat terrain (in Denmark) and complex terrain (in the USA). The instrumentation gives a much more detailed picture of the wind field than would ordinarily be the case. This makes it possible to pinpoint the significant sources of error in the complex terrain situation and enabling us to develop improvements to existing methods such with the aim of improving the accuracy of the measurements.

The experimental set-up consists of four heavily instrumented meteorological masts with instrumentation including among others wind speed measurements with cup and sonic anemometers, wind direction, absolute and differential temperatures, barometric pressure and precipitation measurements. The reference mast M1, is placed at the slope of a ridge while the two masts (M2, M3) are situated at the top of the ridge at the turbine position. The slope of the ridge is of the order of 25-30%.

The wind accelerates moving from the slope to the top of the ridge and the degree of acceleration depends on the terrain slope. The shear of the wind profile is larger in the case of the complex terrain as compared to the flat terrain. The inclination of the wind in complex terrain is both a function of the local terrain slope and the distance from the ground. Finally the wind speed measurements at the ridge top show a flat wind profile with zero inclination to the horizontal .



In general these results confirm that the measurement of the wind speed at hub height is not necessarily representative of the wind speed over the whole rotor plain. Another aspect of the site calibration measurements in complex terrain concerns the behaviour of the cup anemometers. Earlier work has shown that the response of cup anemometers depends on their inclination to the wind. Sonic anemometer measurements reveal large variations of the inclination angle at the reference mast and at hub height, especially at lower wind speeds where atmospheric stability influences are larger. The site calibration takes care of the acceleration between the two locations but cannot solve the problem of the different response levels, which will eventually affect the power curve measurement exhibiting faulty large spreading of the values. There are thus more uncertainty sources than those described in the present standards and recommendations. Some of them will be addressed in the

present project. The result is expected to be: a) a new and more concise site calibration method; b) new recommendations on the site calibration and power curve assessment issue in complex terrain

Acknowledgements: EU financing contract JOR3-CT98-0257, co-financing Danish Energy Ministry, NEG Micon financed the costs associated with the overseas activities.

References:

- [1] "Wind turbine generator systems – Part 12: Wind turbine power performance testing", IEC 61400-1
- [2] "Power performance measurement procedure", MEASNET, ver. 2, 2000

## 9 Measuring and Data Technology

*Søren E. Larsen*

### Objective

Selected Development and implementation of meteorological and wind power measuring and data management systems for use in the departments' experimental and monitoring tasks. The activity is mainly performed in connection with the departments research programmes but also directly for external customers. Specifically is included in this task the delivery and service of the instruments and systems to external users. The activities of the tasks are performed on programme research or commercial terms dependent on the specific task.

### Selected developments and results for 1999-2000

During 1999 the task was named Experimental Meteorology (EME) with basically the same objectives, as listed above. However during the 1999-2000 reporting period fairly large changes took place within the activity. Out of the department, a small private company, MetSupport, was formed with three persons from EME and one from the programme Atmospheric Transport and Exchange (ATU). With the department as a main customer this company set out develop the market for implementing meteorological measurement tasks with associated data handling and organisation. In the beginning of 2000 the task, now named MDT, was strengthened by receiving a group working with instrumentation and data system development from another Risø department. As a consequence, during the period 1999-2000, the task was weakened considerably with respect to field operations and strengthened on the instrument system and data system development. Therefore, a fairly large fraction of the normal field operations and data handling has been sub-contracted to the company, MetSupport. On the other hand many new demands for instrumentation and measuring systems, especially within wind energy activities, have expanded this part of the activity.

The instrumental development has mainly been characterised by a continuing gradual improvement and perfection of basic instruments like cup-anemometers, wind-vanes and Pt-thermometers. This gradual improvement has occurred throughout the history of the department and benefits from that MDT is both an instrument builder and an instrument user, ensuring optimal communications demands to instruments as well as experienced shortcomings. As a consequence these basically very simple instruments continues to become better documented, robust against damage, while calibrations become more robust against long term drift.

During the reporting period, MDT has however also been involved in instrument development undertaken by the other programs of the Department, such as the Relaxed Eddy Accumulation (REA), the boundary layer LIDAR and equilibrators for measurement of air-sea exchange.

An important improvement for the set-up of experiments and monitoring activities has been achieved through the development of a multipurpose data acquisition unit. This allows for simplified interface between the data sampling and storing system and the wide variety of different instruments in use in modern meteorological and /or wind energy measuring activities.

Many of the monitoring activities of the department take places at locations that are not easily accessible from Risø. Either because the location is remote, as e.g. a wind climate station in Kazakhstan in Central Asia, or at sea, as is the case for the off-shore wind energy evaluation sites in the Danish waters. To facilitate the data monitoring and hence speed-up the necessary instrumentation service, several systems for real-time data monitoring from Risø have been adapted, including as the most normal transmission through normal telephone lines, but also communication lines through mobile telephones and satellite communication is being employed. Aside from data inspection the system make possible diagnostic analysis of the remote data system from Risø. These have vastly improved the data quality from such measurement. As a side benefit such procedures have made it possible to display real-time data on the Web-site of the department, for the benefit of the department and other interested partners.

Additional to the monitoring activities for internal and external partners, MDT as well is charged with continuation of long term measurements from meteorological stations, where it is deemed important that the data collection continues, in spite of absence of specific partner a any given time. At present five such stations are in operation, of which the Risø Meteorology Mast is the largest. These monitoring station are maintained by the same organisation within MDT, that run and supervise a number of monitoring stations that are established for specific projects.

## 9.1 Development of data acquisition equipment

*Ole Frost Hansen*

### Wind measurement stations

A number of wind measurement stations have been developed and delivered as part of the department's international consultancy activities. They have been deployed in several countries such as Kazakhstan, Lesotho, Tanzania, Denmark including the Faroe Islands, and in Egypt. A total of approximately 30 stations are now in operation. The stations are based on a commercial data logger furnished with commercial as well as Risø developed sensors and signal conditioning units.

The stations operate very reliable, and they provide very accurate wind data adequate for wind energy resource assessments and wind power feasibility studies. Power consumption is extremely low, which enables the stations to operate unattended for up to a year on a standard battery pack.

To enhance the performance of the stations a wind speed processor, based on a digital signal processor, has been developed. Two times per revolution of the cup anemometer, this device measures the time for a complete revolution, and calculates wind speed statistics, i.e. mean, standard deviation, gust and lull, for each scan interval of the data logger. This information is transferred to the data logger at the end of the scan interval.

Data is stored locally, and in addition data may be downloaded from a station via a modem and a telephone connection. However, especially at remote locations where a telephone connection is not available, there is an even more pronounced need for supervising the operation of the station as well as for fetching data, in order to save service visits. To fulfil that requirement, a satellite link is being developed. This link will utilise a new system based on several Low Earth Orbiting satellites, which will provide continuous world-wide coverage. The satellite link will be controlled by a user-program downloaded in a satellite transceiver. Communication parameters such as data transmission interval, number of records, number of channels etc. will have to be set up via a menu driven program before deployment. Data are received in e-mails a few seconds after transmission from the station.

### Data acquisition unit

Often the research activity conducted by the department involves implementation of measurement systems on wind turbines and on meteorology masts. During the past years these measurement systems have become more and more modular in order to increase the flexibility and decrease the complexity of installing the systems. Recently the P2858a Data Acquisition Unit has been developed to extend this modularity and simplify the task of setting up a measurement system. Along with our existing and constantly evolving sensors and signal conditioning units the P2858a Data Acquisition Unit makes up a simple but yet powerful 'Plug & Play' data acquisition equipment.

The P2858a Data Acquisition Unit is based on an embedded microprocessor system and provides 16 high-resolution analogue input channels and 6 general-purpose digital input channels. Two serial ports are provided for configuration and for transmission of measurement data. A number of functions may be selected for the digital input channels including:

- Simple status detection;
- Measurement of frequency modulated sensors such as cup anemometers;
- Measurement of rotor speed and rotor position on wind turbines.

Compared to other data acquisition units the P2858a Data Acquisition Unit provides extensive built-in transient protecting enabling the unit to be used in outdoor environments without the need for an external and complex circuit protection. For use over long distances the unit is prepared for an extension with fibre optic communication interfaces.

In order to make the P2858a Data Acquisition Unit more flexible, it has been designed to accept a wide supply voltage range and to operate in an industrial temperature range.

## 9.2 Monitoring atmospheric climate variables

*Gunnar Jensen, Arent Hansen and Søren Larsen*

From the start of Risø an important part of the obligations for the meteorologists have been to monitor the local climate from Risø's Meteorology Mast and from the data to compute dispersion meteorological statistics, used when estimating environmental loads from the nuclear reactors at the site. This activity is continued today, but has since been joined and superseded by extensive climate monitoring activities aimed at more diverse areas as: Wind energy resource estimation, wind load statistics, dispersion climatology, general climatology and other long term meteorological monitoring. Today the climate measurements associated with wind energy by far dominates the activity.

Because of the long experience with climate measurements of the key personnel in the department, the data survey methodology is based on long continuous experience with the ways faulty meteorological data can be diagnosed. Simple and characteristic errors are detected by many partly automatic methods. The less obvious errors, such as slow changes in instrument or data system characteristics, are mainly detected from inspection of the simultaneous time traces of the different measurements, both from the same station and from different stations. In the reporting period most of the work, involving a wide variety of quality assurance, quality control and service and repair work, both at Risø and at the sites of the various measurements, has been organised within the task of Measuring and Data Technique (MDT). Mostly only the work at Risø has actually been carried out by MDT personnel, while most on-site activities are carried out by local people, or by the project people erecting the stations, and last but not least in co-operation with a private company MetSupport Aps, a company that developed from MDT in 1999 as a commercial branching out of MDT activities.

The group responsible for operating the monitoring stations are also strongly involved in development and calibrations of some of the key instruments. This ensures that all instrument problems showing up in the field operations are integrated in the evaluation and modification of these instruments.



A typical climate monitoring station is based on a mast, between 10 and 50 m tall; the 127 m Risø tower is presently somewhat extreme. The measurements include typically wind directions and wind speed and temperature in several heights, followed often by other data as radiation, humidity and certain turbulence statistics. For a few stations the turbulence statistics is based on sonic anemometers, but mostly it derives from cup anemometers and wind vanes. The data are typically presented as 10 minute averages of both mean values and turbulence statistics. The data are transmitted back to Risø by various means, from the most simple of mailing the data storage units, to various direct data transmission methods, such as direct telephone links that are used when possible, satellites or mobile phones that are used when necessary and possible.

At present the group manages about 55 meteorological measuring stations, of which more than 35 are aimed at wind power resource evaluation. A few are aimed at dispersion climatology or general climatology, and a number serves different applications.

*The Geographical distributions and use of climate stations are presently:*

Denmark: 13 stations with applications within wind energy, dispersion climatology, general climatology;

Greenland: 1 station aimed primarily at continuation of a long data series on general climatology;

Kazakhstan: 4 station for wind energy applications at Djungar Gate, one of the most windy places in the world;

Egypt: 27 stations aimed at mapping of the wind power resources as basis for an Egyptian Wind Atlas;

Africa (outside Egypt): 3 stations aimed at wind power resource evaluation.

Additional to these stations the group is partially involved in data quality assessment for a number of measuring stations on the Faro Islands and in Sweden. The map above shows the Danish Risø measuring stations publicly available with real time data from the Web site of the department of Wind Energy and Atmospheric Physics.

As "Measuring and Data Technology" to a large extent service the research programs of the department, these of course constitute the main partners and sponsors of the activity. The external sponsors responsible for most of the measuring stations, therefore reflect the profile funding of the department with respect to experimental projects. Although most of the stations in operation reflects ongoing projects, the department continues to operate a few of the measuring stations after the initial projects have ceded, to ensure that long time series become available, for selected locations.



## 10 Risø International Wind Power Consulting

*Jens Carsten Hansen*

Risø offers consulting services to clients world-wide. Since 1980 Risø has participated in numerous international wind energy projects and technology transfer activities. The staff has extensive experience and knowledge in wind power, developed through decades of research. Risø acts on contract as *Consultant* and *Technical Advisor* offering various kinds of *Technical Assistance* in different types of projects. Services are provided to many kinds of national and international project stakeholders such as authorities, industry, developers, investors, banks, donor agencies, and development organisations. Products and services are being provided in more than 70 countries.

### **Mission**

Risø International Wind Power Consulting aims at utilising available know-how and state-of-the-art tools interacting with research to contribute to:

- Development of wind power technology and applications;
- Promotion of sustainable wind power solutions and products;
- Development and implementation of international projects;
- Development of methods and tools for project studies and project implementation.

### **Wind farms**

Services may include project design, planning, monitoring and co-ordination, involving issues related to wind turbine and wind farm design and standards, siting, sizing, layout, energy production estimation, impact on power quality, environment as well as project implementation, testing and performance verification measurements.

### **Decentralised power systems**

The services involve project and system design with power system modelling for integration of wind power and other renewable energies, including supervisory control systems, operational strategies, power mix, grid design, power quality and impact on power system components. Risø acted as principal adviser in the Cape Verde project, which since 1995 has supplied 15% of Cape Verde's electricity. Risø studied the further expansion to 35% penetration.

### **Measurements and tests**

Since 1995, Risø has been accredited to perform measurements according to the European Standard EN 45001 "General Criteria for the Operation of Testing Laboratories". Risø offers wind turbine tests and measurements of Power Curves, Performance Verification, Safety Systems, Noise, Grid Interface, Yaw Efficiency, Structural loads, System Function. Wind turbine testing and measurement programmes are often carried out as separate projects, including supply, installation and operation of measurement equipment as well as data analysis, evaluation and presentation of results and recommendations.

### **Technology centres**

Risø interacts in the international network of wind energy technology centres, and is as such engaged in design and supply of equipment for technology centres and in establishing type approval and certification schemes. The Egyptian national centre at Hurghada is a result of an institutional twinning project between The Egyptian New and Renewable Energy Authority (NREA) and Risø with funding support from Danida. A similar co-operation exists with the Indian Centre of Wind Energy Technology (C-WET).

### **Wind resources**

Risø developed the de-facto world standard for wind resource assessment (the Wind Atlas method) and the computer software for the necessary calculations and modelling – WAsP. The team of wind power meteorologists offers a complete set of consulting services for any type of wind study.

### **Feasibility studies**

Risø has studied the feasibility of various types of wind power projects, including pilot and demonstration projects, small and large wind farms, wind turbines in isolated power systems, and wind energy technology centres. A wide range of expertise is employed from the Risø research staff as well as from co-operation in teams with external Danish or international consulting firms and experts.

### **Training and courses**

International projects and services are provided through institutional collaboration with capacity building and dedicated training based on training needs assessment. Courses in specific scientific topics within wind energy are often included. Dedicated training programmes may be carried out either at Risø or on location.

## 10.1 National wind turbine test station in India

### *Per Lundsager*

In order to support the manufacturing industry, investors, developers and utilities in the wind energy sector the Government of India has established a Centre for Wind Energy Technology C-WET in Chennai(Madras), which will serve as the technical focal point for wind power development in India, for promoting and accelerating the pace of utilisation of wind energy and for support of the growing wind power sector in India.

In accordance with a government to government agreement between India and Denmark, Danida is providing technical assistance for the development of the capabilities of C-WET in the period 1999 to 2003. Danida has contracted Risø National Laboratory of Denmark as the Technical Consultant to be responsible for the technical assistance.

On this background the main objective of the project is to promote and accelerate wind utilisation in India by establishing national facilities for testing and certification of wind turbines, preparation of standards and certification rules and monitoring of the technical performance of wind turbines in India. The strategy is to establish an independent organisation, which has the organisational and technical capability to perform the above activities, and the strategy is implemented in 2 phases.

During phase 1 of the project, covered by the existing contract for 1999 and 2000, a core professional organisation and facilities for stationary and field power performance measurements have been established and a preliminary type approval system has been developed. Major components in the project include institutional development, training in the form of workshops as well as on-the-job training during testing and certification, and technical assistance with equipment and facilities. During phase 1 Risø National Laboratory has worked in a Project Implementation Plan with the following main activities:

**Project management and institutional development:** In addition to the necessary planning, follow-up and reporting inherent in the project management, institutional development activities during phase 1 have encompassed a marketing strategy and a marketing plan for year 2000-2003, a financial management system for budgeting and financial management of projects and a quality management action plan. In addition to this a Plan for Network Building and an Information and Communication Strategy has been drafted. An extended Training Needs Assessment was carried out in a participatory approach at the end of phase 1, and an extensive Training Plan for Phase 2 was established.

**Human resource development:** A number of training activities has been carried out during phase 1 for both academic and technical core staff at C-WET in India and in Denmark. Courses in India included a basic course in wind energy technology and certification as well as courses in installation, use and maintenance of wind turbine test equipment. Courses in Denmark included training in strain gauge installation, safety of climbing and installation, and standards and certification issues.

**Equipment and facilities:** A range of office and computing equipment was supplied during phase 1 as well as a comprehensive set of workshop equipment. Furthermore, on separate Contract with Danida, two sets of test equipment for field power curve measurements were supplied and, at the end of Phase 1, two sets of a stationary basic system test equipment were provided for the Kayathar test field.

**Procedures and standards:** A quality management system including procedures and instructions for testing and certification was drafted during phase 1, and a Type Approval Provisional System TAPS2000 has been formulated and implemented. In the process a survey of Danish, Indian and international standards were made.

**Operation and on-the-job training:** This has mainly been done on missions to India as part of the ongoing activities at C-WET. During phase 1 two field power performance tests and two basic type tests at Kayathar have been carried out, and reports are in the process of being finalised. Certification based on TAPS2000 has been initiated. On-the-job training has been carried out in the context of these activities in the form of workshops, courses and participatory interaction.

The second phase is scheduled to be completed in year 2003 with outputs that include a fully developed core organisation, a QMS system ready for accreditation as well as test facilities in Kayathar for full system testing programmes. Proven capabilities for field load testing, extended power quality testing and full system testing will be established as well as criteria and procedures for certification and monitoring, the latter including guidelines and standards for safety requirements, design and tests for Indian conditions

## 11 Wind turbine testing

*Jørgen Højstrup*

### **Objective**

Research based, internationally accredited testing of wind turbines in relation to certification, general documentation and support of the industrial development of wind turbines. The testing is generally performed as field testing on a commercial basis.

### **Mid-term goals**

Maintain or increase the high quality of the test measurements and at the same time perform cost optimisations to be able to do well in the ever increasing competition in this field. The medium-term goals are:

- To optimise the use of our technicians in field measurements. From the start of 2001 all of the technicians in the department that are involved in field measurements on wind turbines and in general boundary layer experiments will be available in one group. This will make it possible to use this part of the staff more efficiently, especially since there is a negative correlation between the timing of wind turbine measurements (generally high activity in autumn and winter with high wind speeds) and the boundary layer experiments (highest activity in spring and summer, where conditions for general field experiments tend to be more favourable);
- To start operation on the planned test station for MW sized wind turbines in the high-wind climate on the West Coast of Jutland (Høvsøre);
- Finalise development, test and document the new front end to our data acquisition system. A general front end to the measurement system has been developed, greatly simplifying the setting up and operations of the measurements, and at the same time increasing the reliability;
- Finalise development, test and document new software for the data acquisition system. The existing software which is highly specialised, lacks documentation and is DOS-based, and therefore it was decided to start developing new simpler WINDOWS based software founded on commercially available components;
- Obtain accreditation for the measurement of power quality;
- Obtain accreditation for general wind measurements.

### **Selected results 1999-2000**

In general results of the commercial measurements are confidential, and therefore no selected results are shown here.

## 11.1 Experimental investigation of ultimate loads

*Søren Markkilde Petersen*

The verification of structural integrity of a wind turbine involves analysis of fatigue loading as well as extreme loading. As the turbines increase in size the ultimate loads seem to be relatively more important. Within VEA several projects have focused on this topic during the recent years. One of them, "Experimental investigation of ultimate loads", was initiated in order to increase the database for extreme events. The database will be used in verification and improvement of the design basis for wind turbines and for verification of aeroelastic codes.

It is encumbered with some uncertainty to set-up an experiment and expect to measure something extreme during short periods. Nevertheless, December 3, 1999 a hurricane hit Denmark. The measured wind speed during the storm was the highest ever-observed in Denmark. Selected load measurements from that incidence are seen here.

The specific objective of the project was to perform measurement campaigns at selected sites with high wind. Moreover, to collect special events from ongoing/earlier measurement campaigns, where extremes have been observed. The project is performed in co-operation with NEG Micon and sponsored by The Danish Energy Agency.

### Estimation of ultimate loads

The ultimate design condition is normally defined as the one-year extreme, which on average occurs once in a fifty-year period. Obviously, it is not possible to estimate these extremes based only on measurements. Therefore, statistical methods have to be applied in combination with measurements and simulations. One method is first to categorise the structural loads according to the inflow turbulence condition and to the operational condition and next establish the corresponding extreme load distribution for these conditions. When an extreme distribution, associated with a certain recurrence period is known, extreme distributions with longer recurrence periods, for example one or fifty years, can be calculated. This has been done on a very intensive wind and load measurement campaign carried out in Oak Creek. Oak Creek is located near Tehachapi in California US. The conditional extreme distributions from this measurement campaign have been shown to follow an Extreme Value 1 (EV1) distribution. The EV1 distribution is shown to become valid both for loads parameters which are mainly stochastic and for loads parameter which are mainly deterministic. The synthesis of the conditioned distributions and the unconditional distribution has been performed by means of a Monte Carlo simulation assuming the wind climate model proposed in the IEC standard. The method is universal and can be used if the relevant conditioned distributions can be derived either from measurements or from calculations.

### The hurricane on 3 December 1999

The third of December 1999 a hurricane hit Denmark. The strongest winds were observed in the southern part of Jutland close to the coastline. Fortunately an intensive load measurement programme on a large NEG Micon wind turbine was going on in this area. The measurements during the passing of the storm were kindly provided by NEG-Micon. The maximum 10 minutes average was observed at 18:22. The actual mean wind speed was 38.4m/s and the corresponding maximum value was 56.0m/s. This is the highest wind speed ever observed in Denmark. This value should be exceeded once per 300 years according to the Danish code. The 10 minutes average wind speed during the incident is shown in the Figure above.

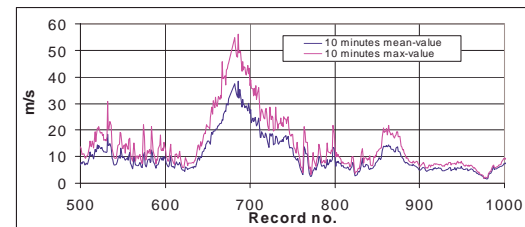

Some examples of the load response (flapwise bending) during the storm are seen in the Figure to the right. These measurements are unique and will be used further in verification and improvement of the estimation of extreme loads. The observed (stand still) loads, during the extreme hurricane, were smaller than the loads associated with normal operation.

### Summary

During the project more than 2 years of intensive wind and load measurements have been carried out in Oak Creek, and, in addition, data from the most severe storm ever observed in Denmark have been made available for the project. The high wind speed data is available at <http://www.winddata.com> in *Database on Wind Characteristics*. The extreme estimation method is described in the Proceedings from the European Wind Energy Conference in Nice, 1999. The concluding analysis of the data has not been performed yet. The final report will be available mid 2001.

The strongest winds were observed in the southern part of Jutland close to the coastline. Fortunately an intensive load measurement programme on a large NEG Micon wind turbine was going on in this area. The measurements during the passing of the storm were kindly provided by NEG-Micon. The maximum 10 minutes average was observed at 18:22. The actual mean wind speed was 38.4m/s and the corresponding maximum value was 56.0m/s. This is the highest wind speed ever observed in Denmark. This value should be exceeded once per 300 years according to the Danish code. The 10 minutes average

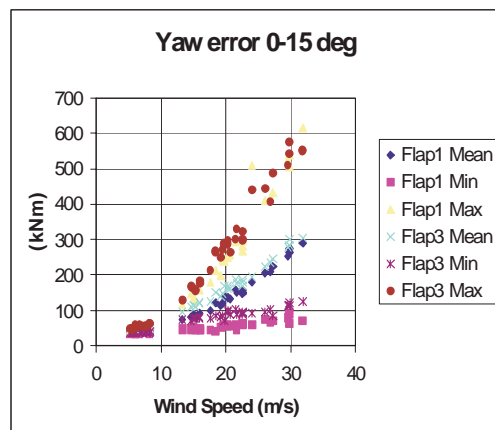

## 12 The Wind Turbine Blade Testing Centre (Sparkær Centre)

### *Carsten Skamris*

Wind turbines with a rotor diameter exceeding 2 metres have to have a type approval in accordance with the Danish approval system. The Sparkær Blade Test Centre situated in Sparkær near Viborg in Jutland is able to perform blade tests with the aim of certifying the above approval.

Since 1981 Risø has tested rotor blades. The original blade test facilities at Risø became gradually too small for the fast growing wind turbine blades. Therefore, in 1991 Risø made a major step forward, by taking over the Sparkær Blade Test Centre, which has carried out blade tests since 1984 on private basis.



Now the Sparkær Blade Test Centre is an integrated part of the Wind Energy Department at Risø National Laboratory.

In 1997 the test facilities at Sparkær were substantially extended with a new test hall equipped with test rigs allowing tests of rotor blades up to 42 meter in length.

The most critical parts of a wind turbine are the rotor blades. Failure of a rotor blade in service often involves damage of the entire turbine. The economical consequences of a rotor failure can be devastating to a wind turbine project wherever situated on the globe. Although most blade designs and calculations are now performed on computers there is a strong need to verify these calculations by full-scale blade tests. Full-scale static and fatigue tests normally cost relatively little compared to the price of one single rotor blade.

Static blade tests are performed in order to determine the structural properties of a blade including natural frequencies, stiffness data and strain distribution. The reported data enables certifying bodies to compare measured data to the calculated data of the design criteria. Thus full-scale blade tests are an essential part of the approval process. Design engineers in the process of enhancing structural design concepts also use test results.

Fatigue blade tests are performed in order to determine the fatigue properties of a blade, which means to verify that the blade has an adequate durability (fatigue resistance). The reported data enables certifying bodies to compare measured data to the calculated data of the design criteria. Thus full-scale blade fatigue tests are often an essential part of the approval process. Design engineers in the process of verifying enhanced structural design concepts also use test results. Blade failures observed in the field can also be duplicated at a fatigue test.

Having tested rotor blades since 1984 the Sparkær Blade Test Centre, as part of the Wind Energy Department, was in 1998 accredited according to the European Standard EN 45001 "General Criteria for the Operation of Testing Laboratories". The accredited measurements are:

- Static blade tests;
- Fatigue blade tests;
- Determination of natural frequencies.

In 2000 the Sparkær Blade Test Centre became independently accredited by DANAK.



Reg. nr. 427

## 12.1 Fatigue blade tests

*Erik Grove-Nielsen*

Fatigue blade tests are performed in order to determine the fatigue properties of a blade. The reported data enables certifying bodies to compare measured data to the calculated data of the design criteria. Thus full-scale blade fatigue tests are often an essential part of the approval process. Design engineers in the process of verifying enhanced structural design concepts also use test results. Blade failures observed in the field can also be duplicated at a fatigue test.

Accredited fatigue tests performed at the Sparkær Centre normally consists of the following standard parts:

- Edgewise fatigue test of 5 million cycles;
- Flapwise fatigue test of 5 million. Cycles;
- Final static proof test.

A typical fatigue blade test includes the following. The blade is bolted to the test rig with vertical tip chord. A static test is performed to obtain strain- and stiffness information for the blade. For each test direction up to app. 60 strain gauges measures strain in the blade skin or blade internal structure. The edgewise test of 5 million cycles is then performed. A frequency converter, controlled by a computer, power the electric motor exciter mounted on the blade. The blade oscillates at a frequency close to its natural frequency. The control system ensures that the peak-peak root bending moment of the test is kept constant. In some edgewise tests a flapwise constant load is applied to the blade, simulating an average wind load.

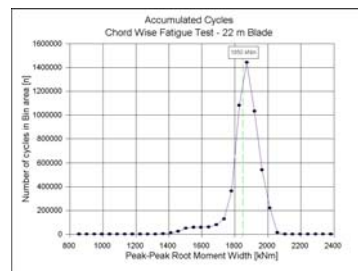

The load spectrum of the test is obtained from information stored in bins on the computer hard disk. For each cycle, the root bending moment width (peak-peak) is determined and stored, to give the moment width spectrum. For each 10.000 cycles a scan of all strain gauges are performed automatically, to give the strain width at every gauge position. At regular intervals of one million cycles a static test is performed.

After the edgewise test, the blade is turned, to have the tip chord in a horizontal position for the flapwise test. The main exciter is mounted at approximately 75 % blade length. A mass pre-load is mounted on the main exciter to give the desired average root bending moment. A dead load exciter is placed near the tip to give the correct bending moment distribution. The blade is now subject to 5 million cycles at a constant root bending moment width.

As the blade interior is accessible through the blade root, design engineers can study movements of the internal blade structure, while the fatigue test is running.

Following the fatigue test, a final proof test is performed to verify that the remaining strength of the blade is sufficient for safe operation of the blade.

## 12.2 Static blade test

Erik Grove-Nielsen

Static blade tests are performed in order to determine the structural properties of a blade including natural frequencies, stiffness data and strain distribution. The reported data enables certifying bodies to compare measured data to the calculated data of the design criteria. Thus full-scale blade tests are an essential part of the approval process. Design engineers in the process of enhancing structural design concepts also use test results.

Accredited static load tests performed at the Sparkær Blade Test Centre consist of the following standard parts:

- Determination of physical properties;
- Determination of natural frequencies;
- Flapwise proof test;
- Edgewise proof test.

A typical blade test includes: After receipt of the blade the blade length, mass, own weight moment and centre of gravity are determined. Strain gauges in a number of 60 – 150 are applied to the blade skin and internal blade structure. The blade is bolted to the test rig. Structural damping and natural frequencies are measured.



At the flapwise proof test 6 or 7 loading clamps are attached to the blade. Loads are introduced in all points simultaneously. The bending moment distribution of the test can be compared to see if it match the design load distribution calculated by the blade designer. The shear forces introduced with multiple point loading are more realistic, compared to the single point loading procedure. Remote controlled electric hoists or hydraulic systems introduce the loads. Load cells measure the imposed forces.

Electric remote sensors measure the deflections at 6 or 7 positions. A strain gauge scanner processes strain gauge signals. All measured values are stored. The edgewise test as well as the flapwise test is normally performed in two directions: in the rotor thrust direction and opposite to that. Again, simultaneous multiple point loading can be introduced.

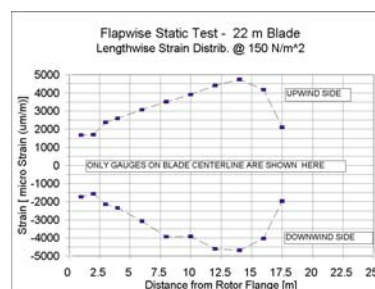
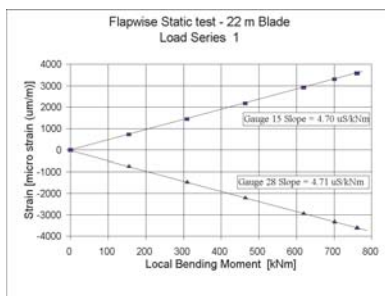

The most essential data obtained at the test are the strain values measured on the blade surface. Non-linearity of the graphs often indicates that structural buckling in the blade skin is building up, although difficult to spot at an early stage. The slope of the strain graph is essential information for the verification of the structural blade design. The length-wise presentation of the strain distribution can reveal high strain gradients that could reduce the fatigue life of the blade.

Failure of megawatt size turbine blades can represent a significant safety risk to engineers and technicians involved in the test, and therefore a special designed impact resistant mobile shelter has been developed and manufactured. All personnel and data acquisition equipment are situated here throughout the test loading, and measurement equipment is remote controlled.

### 13 Exploratory Projects

*Erik Lundtang Petersen*

The research in the Department of Wind Energy is disciplined, supervised and constrained by Risø as well as external sponsors, through well-defined objectives and expectations to the department.

Additional to the disciplined research the department is encouraging some scientific freedom manifesting itself as projects and activities that go beyond current plans and strategies. For the individual scientist such projects serve as breeding ground for new ideas besides being new, funny and interesting. For the department these special projects serve as sources of possible new approaches. They also broaden the profile of the department in relation to many of the professional groupings represented in the staff of the department.

For the reporting period, four representative projects have been selected. The first project concerns application of laser anemometry to monitor the wind in front of a wind turbine, within an area where such intriguing measurements are demanded to be simple, robust, and cheap. The second project describes atmospheric field experiments on the planet Mars, measurements that will not obviously be directly applicable to support the strategic objectives of the department. The third project is a fundamental laboratory tank experiment to study isotropic small-scale turbulence diffusion in a department where most activity involves either field measurements and/or computer modelling. The final example describes a hybrid system of photovoltaics and wind power, thus relaxing a bit the strong focus of the department on conversion of the momentum of atmospheric flows to wind energy.

Finally it should be mentioned that although these projects go beyond the current mid-term goals of the department, they are financially "main-stream" in the department as they have been initiated only after support from external sponsors.



### 13.1 Laser anemometry for control and performance measurements on wind turbines

Sten Frandsen

The general objective of the project is to improve the market position of wind power by reducing cost of the energy produced and by enhancing the credibility by more accurate performance assessment. The project carried out at the Optics and Fluid Dynamics Department deals with the construction of a flexible and portable instrument that remotely measures wind velocities in front of the wind turbine. These measurements would be attractive in order to gain the energy production coming from wind power. A laser anemometer is found to constitute the most flexible instrument for performing remote measurements of the wind speed.

The laser anemometer shall be mounted on top of the nacelle and focus a single laser beam in front of the wind turbine. The velocity of the wind is determined by measuring the introduced Doppler shift of the laser light, scattered backwards from the aerosols in the beam waist. The measurement should be done so far away that the measured wind is unobstructed by the turbine and a 'feed forward' control, which compensates for the response time of the turbine itself, could be applied. These two requirements have led to a target measuring distance of 150 m. Based on the properties of available lasers the CO<sub>2</sub> laser with an optical wavelength of 10.6 μm has been selected. We do not find that it is likely that solid-state lasers will be advantageous for this application within the foreseeable future.

It is well known that feedback into a laser may perturb the power level. In fact, if the backscattered light is fed into the laser, the optical power of the laser will be modulated at the Doppler shift frequency. An autodyne detection system based on this concept would intrinsically be much simpler and more robust than a heterodyne system with external mixing. Also, the alignment of this set-up is much simpler than for the heterodyne system. Investigations on whether such an autodyne system is suitable for the anemometer and the design criteria's for the laser to be employed are under progress. In the autodyne scheme considered here, the light received from the measuring volume returns back through the same telescope as the transmitted beam and enters the laser whereby the laser is perturbed. The modulations on the laser power are measured by extracting approx. 80 mW of the power from the rear laser output to the detector. The telescope, planned for the anemometer, consists of two off-axis parabolic mirrors, a small convex mirror in front of the laser and a large concave output mirror focusing the output beam. Simulations predict that the system is capable of giving diffraction limited focusing of the output beam. The cost price of the mechanics to fix the optical components is high, but especially the cost of turning of the mirrors in metal is extremely high. A method to obtain a minimum price of the laser anemometer in volume production is to use a casting technique of especially the mirrors for the telescope and the mechanics for the fixing of the optical components. When comparing the elastic modulus of composite materials made of carbon fibres,  $E \approx 9300 \text{ N/mm}^2$ , with most metals, these materials seem feasible for the production of both the mirror surfaces and the whole optical assembly. A further investigation of the usefulness of these materials is in progress. Building the mechanics for the laser anemometer in composite materials combined with the telescope configuration chosen enables a compact and low-weight construction of the laser anemometer

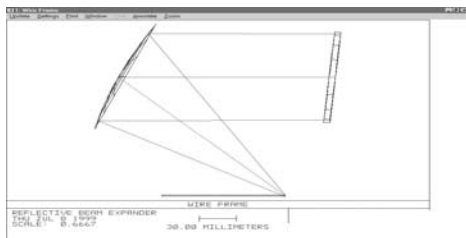

Figure 1 The telescope planned for the laser anemometer. The telescope consists of two off-axis parabolic mirrors. The output from the laser is incident on the small mirror at the bottom of the figure. The window at the output is for protecting the whole optical system.

### 13.2 The atmospheric boundary of Mars from the Pathfinder data

Søren E. Larsen and Hans E. Jørgensen

The Martian atmosphere is the first atmosphere outside Earth, where the formulas and relations derived and tested for the Earth atmosphere can be tested. The universality of many of these relations is not a trivial matter for which reason the similarity and differences between the atmospheres of the two planets will show light on our understanding of both.



The structures of mean flow and turbulence of the atmospheric surface boundary layer have been extensively studied on Earth, and some but less so on Mars, where only the Viking missions and the Pathfinder mission have delivered useful data. The department has contributed to the analysis of data from both missions. We participated as part of the science team in the Pathfinder mission, and are presently involved in the planning of the future Netlander mission.

Largely the behaviour of the turbulence and mean flow in the surface boundary layer of both planets is found to obey the Monin-Obukhov and Kolmogorov similarity hypotheses to a similar extent. The largest meteorological difference between the two atmospheres derives from the low air density of the Martian atmosphere. Together with the absence of water vapour this reduces the importance of the atmospheric heat flux in the surface heat budget. On the other hand the low air density forces the kinematic heat fluxes, and associated parameters to higher values than typical on the Earth. The midday boundary layer height is typically 3-10 Km, against 0.3 –1 Km on Earth. The Rayleigh numbers are typically 5 to 10 larger than on Earth. Similarly the higher kinematic viscosity results in that the Kolmogorov scale typical becomes of the order of 30 times larger than on Earth. Also the Martian boundary layers are described by Reynolds numbers of the order of  $10^7$  being in between the characteristic value for Earth boundary layer,  $10^9$ , and the boundary layer in a wind tunnel being around  $10^5$ .

The air temperature data of the Pathfinder meteorology station are superior to the earlier Viking temperature data with respect both to sampling rates and number of measuring heights: Pathfinder generally sampled faster for longer periods than Viking, allowing for a better turbulence analysis. Also the Pathfinder meteorology mast sampled at three levels as opposed to only one level on the Viking Landers. On the other hand the wind speed instruments at the Viking missions were generally of higher quality, and it is only now that wind speed data from Pathfinder is being recovered.

Our approach has generally been to evaluate to what extent the turbulence structure in the lowest part of the atmospheric surface boundary layer as derived from the Pathfinder data, with similar results obtained from Earthly experiments. The comparison is made in terms of profiles, turbulence moments and spectra. Generally we find that atmospheric surface layer is well described by our boundary layer formulations also on Mars, although some of the characteristic parameters can be quite different on the two planets. The figure below shows how the parameterised spectral function fit the variance spectral data very well, indeed. Indeed some aspects of these parameterised functions have now been more thoroughly tested on Mars than on Earth, specifically concerning data at low measuring heights.

At present continuation of the activity is planned with participation in the European led Netlander project aiming to place four landers simultaneously on Mars in 2007.

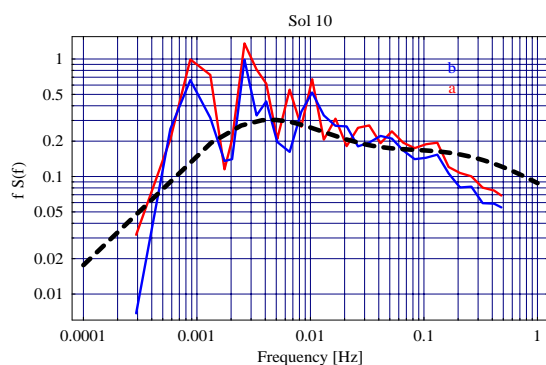

Variance spectrum for two estimates of wind speed fluctuations (a,b) measured at the Pathfinder meteorology station, shown above. Also shown is the parameterised spectral function (the broken line) determined from simultaneous measured mean temperatures and mean wind speeds.

The Danish Research Council has supported the Mars activities. The main partners have been Jet Propulsion Laboratory, Pasadena, California, University of Washington., Seattle and the Finnish Meteorological Office, Helsinki.

### 13.3 A turbulent diffusion experiment

Jakob Mann and Søren Ott

The Particle Tracking project is an experimental study of turbulent diffusion sponsored by the Danish Technical Research Council. The purpose is to conduct controlled experiments, which test turbulent diffusion models. Turbulent diffusion has important applications, in particular within atmospheric dispersion. The need for fundamental turbulent diffusion experiments has been recognised for almost a century, but for a long time direct measurements have been overwhelmed by technical difficulties. The difficulty is to measure so-called Lagrangian statistics, which describes the behaviour of the fluid 'seen' from points that follow the flow. The Particle Tracking project takes up this challenge.

Figure 1 Water tank with oscillating grids, four video cameras and 400 tracks measured simultaneously during one second.

A water tank was constructed for the experiments. Turbulence is generated by means of two oscillating grids, and the water is seeded with neutrally buoyant particles that follow the water flow. Four synchronised video cameras are used to take stereoscopic images, which are digitised and stored on-line by two computers. Software has been developed that reconstructs the three-dimensional positions and identifies particle trajectories in a time sequence. The method allows co-ordinates to be determined with an accuracy of 60  $\mu\text{m}$  within a cube about 15 cm wide.

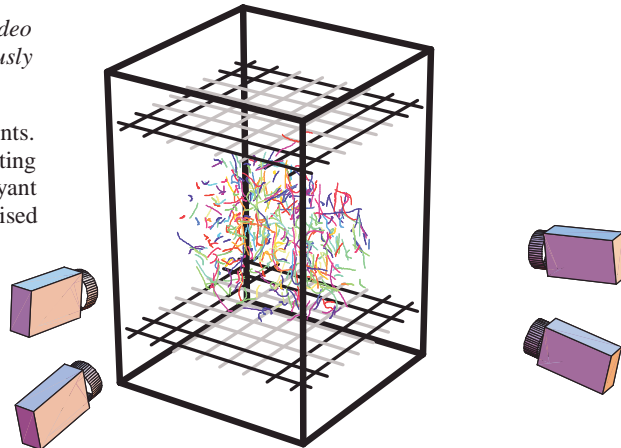

Figure 1 shows the experiment and reconstructed particle trajectories from a 1 second sequence (the whole sequence is much longer). When two particles come within a short distance of each other they have a strong tendency to stay together afterwards. This is because only a small 'eddy' can catch one of the particles without catching the other one also, and in turbulence small eddies are generally rarer than larger ones. Therefore, the particles break away faster as they become further apart where larger eddies can become effective. The term 'anomalous diffusion' is sometimes used to underline the accelerating nature of the process. Investigating the anomalous diffusion was the primary objective.

It is generally accepted that in the anomalous regime the average of the square separation,  $\sigma^2$ , follows the simple law  $\sigma^2 = C \epsilon t^3$ . Here  $\epsilon$  is the rate of energy dissipation per unit mass,  $t$  is time counted from the moment the two particles were close together.  $C$  is the Richardson-Obukhov constant, which is a dimensionless number. Since the formulation of the law, more than fifty years ago, there has been a lack of consensus about the value of the constant  $C$ . Experimental values of  $C$  are scarce, and they scatter over a wide range, roughly between 0.01 and 1. Our measurements, now published in *Journal of Fluid Mechanics* (422, pp. 207-223), narrow this range to  $C=0.4-0.6$ . This interval rules out the majority of the theoretical predictions of  $C$ , many of which are a factor ten too large.

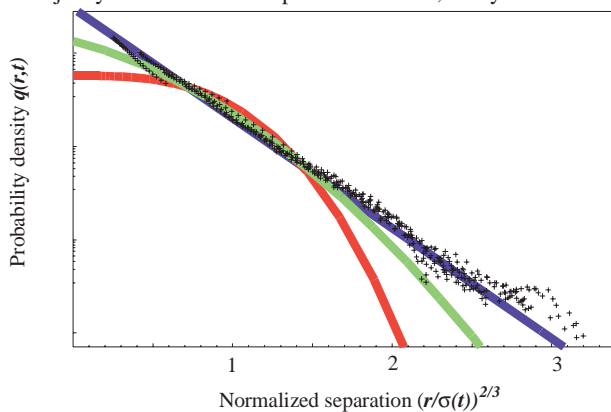

Figure 2 Separation probabilities compared with three theoretical predictions: red Batchelor (1952), blue Richardson (1926) and green Kraichnan (1966).

Results include details about the so-called stance-neighbour function  $q(r,t)$ , a measure of the probability of separation  $r$  at time  $t$ . In Figure 2 experimental results have been plotted along with curves based on three different theories. The experimental data cluster around a single curve, a straight line in this plot, and apparently only one of the theories is consistent with data. This theory is, in fact, the oldest of them all. It is due to Richardson, who invented the concept of relative turbulent diffusion in 1926 and offered the first model for  $q$ . Hopefully, this work will contribute to a fruitful interplay between theory and experiment in his area.

### 13.4 Hybrid power systems with photovoltaics and wind power

Henrik Bindner and Anca Hansen

Currently there are many projects world wide concerned with rural electrification. Due to both economic and environmental issues there is an interest from local decision makers, as well as international financiers (World Bank, Regional development banks etc.), to utilise local energy resources primarily solar energy and wind energy. This interest has not yet developed into a real market for renewable energy based village power systems, mainly due to a lack of proven and documented products as well as lack of a common set of recommended practices and international standards for the implementation of projects.

The recent effort at Risø has been focussing on the development of control concepts for hybrid systems and establishment of tools analysis of pv/battery systems including the test facility. In 2000 a PhD study with the objective of developing a modular framework for control of hybrid systems has been finalised. The reasoning behind the desire for such a framework is that there is a requirement for flexibility due to changes in consumption, outages etc. Risø has participated in Solar Energy Centre Denmark since its establishment in 1998. The role of Risø has been work in the field of stand-alone pv systems and hybrid systems. During 1999 and 2000 Risø has, as a part of the effort in the Centre, established a test facility for stand-alone pv/battery systems and has worked on developing models for such systems.

The PhD study, ref. 1, succeeded in developing of modular control framework for hybrid systems. The framework includes a modular object oriented supervisory controller without principle constrains in the number of pv-generators, wind turbines, diesel generator sets. The object structure is illustrated in the lower part of Figure 1. It can perform the basic control (reading measurements, determine the state of the system, start/stop components), and it can execute different system operating strategies without reprogramming (upper part of Figure 1). Also implementation issues were dealt with and as a part of that, a standard communication protocol was defined in order to ensure that the necessary information is available for the supervisory controller to control the system and to be able to optimise operation. The last main result of that project was a so-called dispatch model that allows detailed modelling of the supervisory control of hybrid systems.

For the further development of pv/battery systems, and in order to better be able to include batteries on a sound basis in hybrid systems, an effort has been made to develop a library of component models in the simulation framework MATLAB/SIMULINK, ref. 2. The models are implemented as standard models in SIMULINK allowing graphical building of systems. The models include pv-panels, batteries, charge controllers, inverters and loads. Special emphasis has been on the battery model, and in order to verify the model and also to gain deeper knowledge of batteries, a battery tester has been built. The tester will be used to investigate how batteries behave when subjected to a load pattern, where the direction of the power changes often and rapidly as it does in hybrid power systems with wind power.

The long-term perspective is the development of an economic and robust hybrid system concept based entirely on renewable energy sources - a system concept that can deliver power of adequate quality for the different and changing loads in locations with a difficult infrastructure.

- [1] A. de Lemos Pereira, Modular supervisory controller for hybrid power systems. Risø-R-1202(EN), IAU 00-A-891, June 2000, Risø Denmark.
- [2] A.D. Hansen, Modelling and control of stand-alone pv/battery systems. Risø-R-XXXX(EN), December 2000, Risø, Denmark.

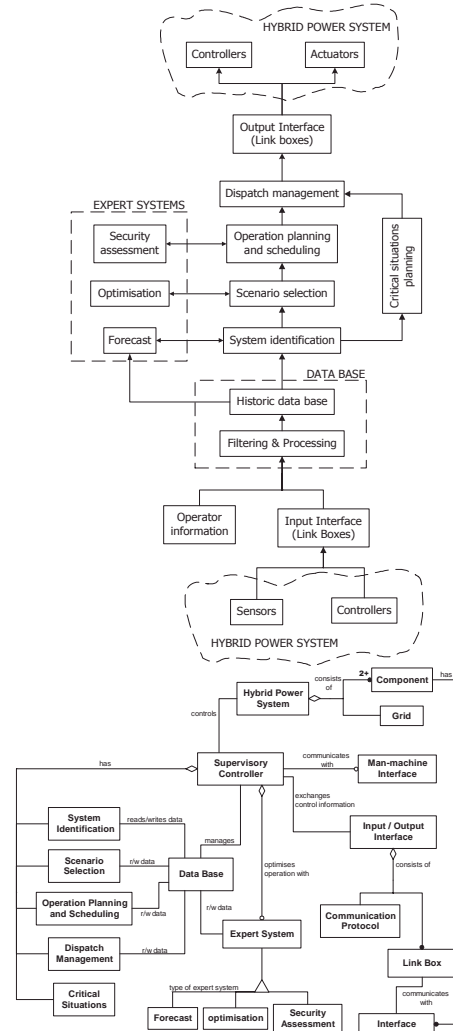

Figure 1 Modular supervisory controller

Title and authors

Wind Energy and Atmospheric Physics Department:  
Scientific and Technical Progress 1999-2000

Birthe Skrumsager and Gunner Larsen (eds)

---

ISBN	ISSN
87-550-2818-7	
87-550-2819 (internet)	0106-2840

---

Department or group	Date
Wind Energy	January 2001

---

Groups own reg. number(s)	Project/contract No(s)

---

Sponsorship

---

Pages	Tables	Illustrations	References
51	3	51	10

---

Abstract (max. 2000 characters)

The activities of the Wind Energy Department fall within boundary layer meteorology, atmospheric turbulence, aerodynamics, aero-acoustics, structural dynamics, machine and construction technology and design of power systems and power system controls. The objective is to develop methods for design; test and siting of wind turbines; prediction of wind loads and wind resources as well as methods to determine the dispersion, transformation and effect of air pollution.

The present report describes the organisation of the department and presents selected scientific highlights and results from the two-year period 1999-2000. Additional information on the department and its activities can be found on World Wide Web (WWW) on the address <http://www.risoe.dk/vea/>. The department's web pages are constantly updated.

Descriptors INIS/EDB

---

Available on request from Information Service Department, Risø National Laboratory,  
(Afdelingen for Informationsservice, Forskningscenter Risø), P.O.Box 49, DK-4000 Roskilde, Denmark.  
Telephone +45 4677 4004, Telefax +45 4677 4013