

Technical University of Denmark



## Investigation of measuring strategies in computed tomography

Müller, Pavel; Hiller, Jochen; Cantatore, Angela; De Chiffre, Leonardo

*Published in:*  
NEWTECH 2011

*Publication date:*  
2011

[Link back to DTU Orbit](#)

*Citation (APA):*

Müller, P., Hiller, J., Cantatore, A., & De Chiffre, L. (2011). Investigation of measuring strategies in computed tomography. In NEWTECH 2011: New Technologies in Manufacturing (pp. 31-42)

## DTU Library

Technical Information Center of Denmark

---

### General rights

Copyright and moral rights for the publications made accessible in the public portal are retained by the authors and/or other copyright owners and it is a condition of accessing publications that users recognise and abide by the legal requirements associated with these rights.

- Users may download and print one copy of any publication from the public portal for the purpose of private study or research.
- You may not further distribute the material or use it for any profit-making activity or commercial gain
- You may freely distribute the URL identifying the publication in the public portal

If you believe that this document breaches copyright please contact us providing details, and we will remove access to the work immediately and investigate your claim.

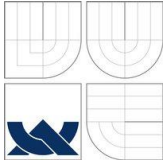

NEWTECH 2011

NEW TECHNOLOGIES IN MANUFACTURING  
ISBN 978-80-214-4267-2



# INVESTIGATION OF MEASURING STRATEGIES IN COMPUTED TOMOGRAPHY

Pavel Müller, Jochen Hiller, Angela Cantatore, Leonardo De Chiffre

Technical University of Denmark, Department of Mechanical Engineering, Kgs. Lyngby,  
Denmark  
pavm@mek.dtu.dk

## ABSTRACT

*Computed tomography has entered the industrial world in 1980's as a technique for non-destructive testing and has nowadays become a revolutionary tool for dimensional metrology, suitable for actual/nominal comparison and verification of geometrical and dimensional tolerances. This paper evaluates measuring results using different measuring strategies applied in different inspection software. The strategy influence is determined by calculating the measuring uncertainty. This investigation includes measurements of two industrial items, an aluminum pipe connector and a plastic toggle, a hearing aid component. These are measured using a CT scanner and compared with reference measurements on tactile coordinate measuring machine (TCMM) and optical CMM (OCMM), to obtain traceability of measurement. Results have shown that diameter measurements of cylindrical features for both parts resulted in small bias (difference between measurements using CT scanner and reference instruments) compared to distance and height measurements. It was found that bias values as well and uncertainties of all measurands calculated in ATOS for the pipe connector were generally bigger compared to measurements in Calypso CT and VGStudio MAX. Bias values of all measurands for the toggle were in the same range for all the three software and uncertainties were in the range of calibration uncertainties. Uncertainties connected with measurement of the distance between two surfaces on the inner flange of the pipe connector from CT scanner were found bigger compared to uncertainties obtained from reference measurements performed on tactile CMM. Uncertainties for measurements of the pillar height on the toggle from CT scanner were found to be in the same range as uncertainties obtained from reference measurements performed on optical CMM.*

**KEYWORDS:** Computed tomography, measuring strategy, dimensional metrology

## 1. INTRODUCTION

Computed tomography (CT), also called CT scanning, is a non-destructive measuring technique, allowing inspection of internal and external geometries of a workpiece. CT is used in many industrial fields (material science, electronics, military, medical, food, security, aerospace and automotive). Some industrial applications when using CT scanning have been reported in [3, 8, 9, 10]. Few years ago CT has become an important player in the field of coordinate metrology. CT is in a relatively short time capable to produce a complete three-dimensional model of the scanned part. One of

the biggest advantages of using CT compared to other measuring techniques, e.g. tactile measuring techniques, is the high density of points acquired on the scanned part. A key issue in using CT scanning is that CT systems are not traceable to the unit of meter and evidence of many influence quantities due to which assessment of uncertainty is rather a challenge. Several studies have been done concerning the problem of uncertainty calculation [2, 11, 13, 15]. An overview of different methods for uncertainty calculation is reported in [8].

A CT system consists of an X-ray source, a rotary table, an X-ray detector and a data processing unit (see fig. 1). A process chain of a typical CT measurement is presented in fig. 2 and

can be shortly described as follows: 1. Scanning of the object (setting up the scanning parameters), 2. Obtaining the volumetric model (voxel data), 3. Surface determination (threshold application), 4. Generation of surface or volume data, 5. Dimensional measurement (e.g. fitting of geometrical primitives, nominal/actual comparison etc.), 6. Result evaluation. Detailed description of the process flow can be found in [6, 8, 10]. There are numerous influence factors in CT scanning which have strong effect on measuring uncertainty and can be categorized into groups, i.e. factors connected to the hardware, software/data processing, environment, measured object and operator [1, 13, 14].

The objective of the present work is to perform geometrical measurements on selected industrial parts using CT scanning. The specific aims are to:

- a) Compare available evaluation software for 3D inspection with respect to measuring strategies
- b) Calculate measuring uncertainty through the assessment of uncertainty budgeting

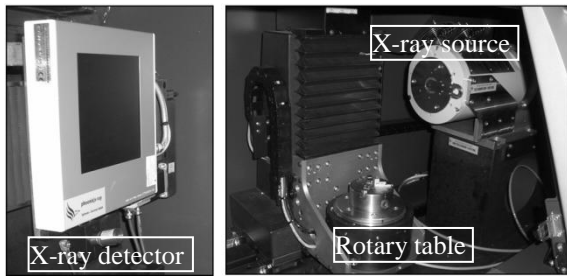

Fig.1. CT system components: X-ray detector (left), rotary table and X-ray source (right).

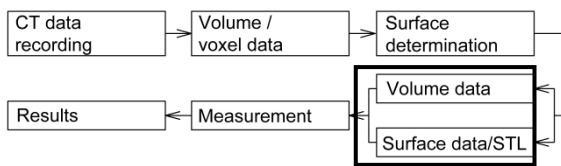

Fig.2. A process chain for dimensional measurement by means of CT.

Table 1. An overview of software packages used throughout the investigation.

Software name and version	Software producer	Measurement performed on
Calypso CT 4.8.10.16	Zeiss	Volume data
VGStudio MAX 2.1	Volume Graphics	Volume data
ATOS Professional V7 SR2	GOM Inspect	Polygonal mesh

Dimensional and geometrical measurements were performed both on volume and surface data (polygonal mesh), which is a process after surface determination, as is highlighted in fig. 2. Three commercial software packages for CT analysis of results were used and are summarized in Table 1.

## 2. CASE DESCRIPTION

Two objects were selected for the present investigation. The first one is a polymer micro component used for a hearing aid application. Particularly, it is a toggle produced by polymer injection molding and is made of liquid crystal polymer (LPC) with a part weight of 35 g. Four measurands (three dimensions and one geometrical) were defined according to [4, 12]. These are: outer diameter ( $D_T$ ), inner diameter of the hole in the middle of the part ( $d_T$ ), concentricity of the two circles ( $C_T$ ), and the height ( $H_T$ ) of the pillar (fig. 3 (left)). The second object is an aluminum alloy pipe connector, manufactured by cold forging and subsequently machined to desired dimensions. This part is used in automotive industry. Five measurands (three dimensions and two geometrical) were defined: inner diameter ( $d_p$ ), angle between the holes placed on the inner flange ( $\alpha_p$ ), distance between the two parallel surfaces of the inner flange ( $L_p$ ), parallelism between the two surfaces ( $P_p$ ) and cylindricity ( $C_p$ ) of the inner hole (fig. 3 (right)).

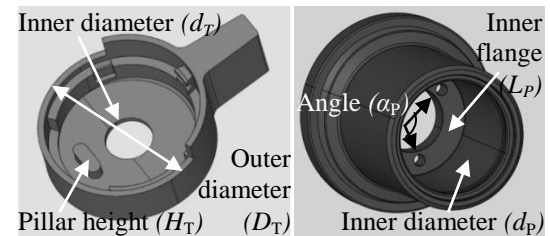

Fig.3. Toggle (left) and pipe connector (right). The measurands are indicated.

## 3. MEASURING SETUP FOR TACTILE, OPTICAL AND CT MEASUREMENTS

### 3.1. Tactile reference measurements

The pipe connector was measured using a tactile CMM (TCMM) OMC 850, with stated  $MPE_{TCMM} = (2.5+L/300) \mu m$  ( $L$  in mm). Measurements performed on the CMM were considered to be reference measurements. This is due to the fact that measurements performed using contact technology generally speaking result in better precision, higher repeatability and ensures traceability of the measurement.

Measurements were performed in a temperature controlled laboratory with temperature of  $20 \pm 0.5^\circ\text{C}$ . Measurements performed on the CMM were realized using three styli with corresponding number of probes. The nominal dimensions (diameter,  $\varnothing$  and length,  $l$ , of styli) are: 1)  $\varnothing 3.0\text{mm}$ ,  $l = 58\text{ mm}$  (axial), 2)  $\varnothing 1.5\text{ mm}$ ,  $l=56\text{mm}$  (horizontal) and 3)  $\varnothing 5.0\text{ mm}$ ,  $l = 53\text{ mm}$  (horizontal), configured so that measurement in all directions was possible without repositioning of the workpiece. All the measurements were repeated three times.

### 3.2. Optical reference measurements

The toggle was calibrated using an optical CMM (OCMM) DeMeet 220, according to procedures described in [4, 12]. The accuracy of this measuring instrument in  $x$  and  $y$  direction is  $\text{MPE}_{\text{OCMM}} = (4+L/150)\text{ }\mu\text{m}$  ( $L$  in mm) and  $3.5\text{ }\mu\text{m}$  in  $z$  direction. These measurements are used as reference measurements.

Table 2. An overview of the parameters which have been used for the Metrotom 1500 CT scanner.

Parameter	Unit	Toggle	Pipe connector
Voltage	kV	130	210
Current	$\mu\text{A}$	150	500
Magnification	-	20.8	3.7
Voxel size	$\mu\text{m}$	19	108
Focal spot size	$\mu\text{m}$	19	105
Integration time	ms	1000	400
No.of projections	-	720	720
X-ray filter	-	-	Cu 0.25 mm
Detector matrix	pixel	1024 x 1024	1024 x 1024
Pixel size	$\mu\text{m}$	400	400

### 3.3. CT measurements

Both parts were then scanned using a Metrotom 1500 cone beam CT scanner. Measurements performed on the CT scanner were reproduced three times. The reproducibility was assessed by scanning the parts in different days and repositioning of parts from the fixture. Scanning parameters are shown in Table 2.

Measuring instruments used in this investigation are shown in fig. 4.

## 4. UNCERTAINTY ASSESSMENT

Measuring uncertainties were calculated for all three measuring instruments, which are in compliance with GUM procedures [7]. All the CT measurements were compensated for systematic error - bias,  $b$ , as follows:

$$b = \bar{y}_{CT} - \bar{y}_{ref} \quad (1)$$

where  $\bar{y}_{CT}$  is an average of three reproduced measurements performed on the CT scanner for each measurand,  $\bar{y}_{ref}$  is an average of three repeated measurements performed on the reference instrument for each measurand.

### 4.1. Uncertainty estimation for tactile measurements

The measuring uncertainty for the pipe connector was calculated as follows:

$$U_{ref,TCMM} = k \cdot \sqrt{u_i^2 + u_p^2 + u_e^2} \quad (2)$$

where  $U_{ref,TCMM}$  is expanded combined uncertainty of the pipe connector measurements by TCMM,  $k$  is coverage factor ( $k = 2$  for a confidence interval of 95%),  $u_i$  is standard calibration uncertainty of the measuring instrument, taking into account maximum permissible error of the machine ( $\text{MPE}_{\text{TCMM}}$ ),  $u_p$  is standard uncertainty of the measuring procedure, calculated as  $u_p = h \cdot (s/\sqrt{n})$ , where  $h$  is safety factor ( $h = 2.3$  for three reproduced measurements),  $s$  is standard deviation of three repeated measurements and  $n$  is number of measurements (3),  $u_e$  is temperature-related standard uncertainty calculated for a deviation of  $\pm 0.5^\circ\text{C}$  and using a coefficient of linear expansion for aluminum of  $23 \times 10^{-6}^\circ\text{C}^{-1}$ .

### 4.2. Uncertainty estimation for optical measurements

The measuring uncertainty for the toggle was in details assessed in [12] and therefore will not be described here.

### 4.3. Uncertainty estimation for CT measurements

The measuring uncertainty of both parts measured using the CT scanner was calculated as follows:

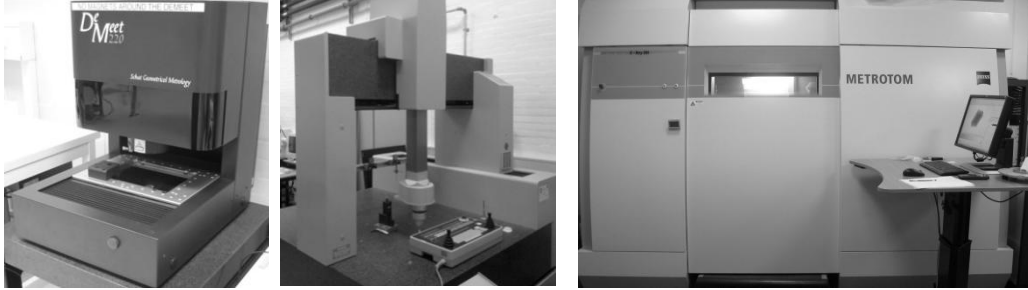

Fig.4. Measuring instruments: Optical CMM - DeMeet 220 (left), tactile CMM – OMC 850 (middle), CT scanner – Metrotom 1500 (right).

$$U_{CT} = k \cdot \sqrt{u_{ref}^2 + u_p^2 + u_e^2} \quad (3)$$

where  $U_{CT}$  is expanded combined uncertainty for both parts under investigation measured by the CT scanner for each measurand,  $u_{ref}$  is standard uncertainty as previously calculated for TCMM and OCMM,  $k$  is coverage factor ( $k = 2$  for a confidence interval of 95%),  $u_p$  is standard uncertainty of the measuring procedure for each measurand, calculated as  $u_p = h \cdot (s/\sqrt{n})$ , where  $h$  is safety factor ( $h = 2.3$ ),  $s$  is standard deviation of three reproduced measurements and  $n$  is number of measurements (3),  $u_e$  is temperature-related standard uncertainty calculated for a deviation of  $\pm 0.5$  °C and using a coefficient of linear expansion for aluminum of  $23 \times 10^{-6} \text{ °C}^{-1}$  and  $49 \times 10^{-6} \text{ °C}^{-1}$  for LPC.

## 5. PROCESS CHAIN FOR DATA EVALUATION AND DEFINITION OF MEASURING STRATEGIES

The focus of this investigation was to perform measurements on simple features, i.e. cylinders, circles, planes, etc. These are features where a single outlier, measured point outside the specified range, will not influence the overall measuring result. This might for example happen if one measures a form error.

A process chain for measurements of both parts using three software packages is schematically shown in fig. 5. The evaluation method for fitting geometrical primitives is least square method (also called Gaussian best fit).

Different measuring strategies for diameter, height, distance and angle measurements for both parts under study were applied in each of the software. Table 3 presents an overview of measuring strategies used for above mentioned measurands. It can be noticed that some measuring strategies are common to all software packages and some are different. This is due to various fitting algorithms which individual software packages are equipped with.

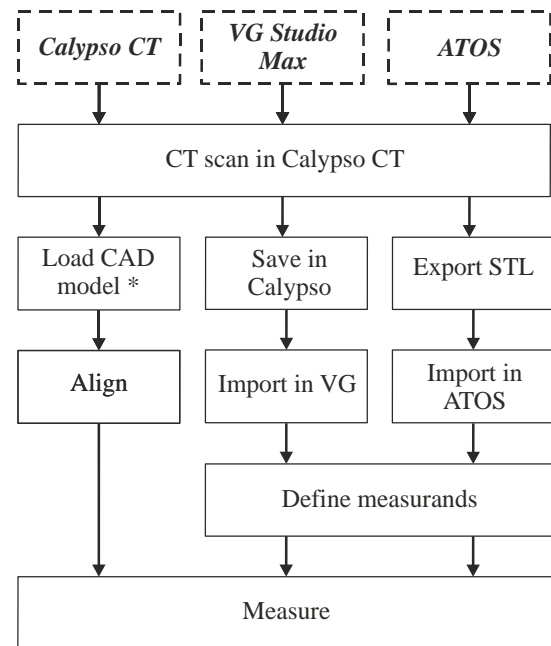

Fig.5. Measuring procedure for selected software.

\*CAD model with already programmed measurement plan.

Table 3. An overview of measuring strategies.

Measurand	Calypso CT	VGStudio MAX	ATOS
Diameter ( $d_p, D_T$ )	Circle	Circle	Circle
	Spiral	Feature fit	Feature fit
	Recall	Cylinder circle	Cylinder circle
Distance ( $L_p$ ) and Height ( $H_T$ )	Plane-Plane	Plane-Plane	Plane-Plane
	Point-Plane	Point-Plane	Point-Plane
Angle ( $\alpha_p$ )	Circle	Circle	Circle
		Cylinder	Cylinder

Diameter (Pipe connector and Toggle):

- **Circle:** measurement is performed at different levels with respect to the position of a reference plane by fitting respective number of circles. Diameter is then calculated as an average value for each of the fitted circles.
- **Spiral:** a spiral is fitted on the cylinder with defined number of revolutions and number of points. Diameter is then calculated as an average value of all fitted points on the helix.
- **Recall:** recalls previously created features (in our case - circles). Diameter is then calculated as an average value of both recalled circles.
- **Feature fit:** by selecting a feature (in our case a cylindrical surface), a best fit cylinder is created on the surface of a respective 3D feature. Diameter is then calculated as an average value of all fitted points.
- **Cylinder circle:** by selecting points in circular cross-sections (in planes perpendicular to the axis of a cylinder) at two levels with respect to the position of a reference plane, the cylinder is fitted in between these levels. Diameter is then calculated as an average value of all fitted points in specified range.

Distance (Pipe connector) and Height (Toggle):

- **Plane - Plane:** by selecting surfaces, best fit planes are fitted. The distance is then calculated by projecting the center point of the fitted plane onto the other plane in normal direction.
- **Point - Plane:** by selecting single points on one surface and fitting a plane on the other surface with respect to which the distance/height is to be calculated, the distance is calculated by projecting each of the fitted points onto the plane in normal direction.

Angle (Pipe connector):

- **Circle:** by fitting circles in the middle height of the three holes of diameter 3.5 mm placed in the inner flange, the angle is calculated between each two holes with respect to the rotational axis of the part.
- **Cylinder:** by fitting cylinders in the three holes of diameter 3.5 mm, the angle is calculated between each two holes with respect to the rotational axis of the part.

### 5.1. Calypso CT

In Calypso CT, the assessment of measurands is programmed on a CAD model (see example applied on the toggle in fig. 6), including positions and number of measured points. When scanning of a part is finished, a surface is defined on the voxel model by applying an optimum threshold. This is however only done to visualize the CT model offering easy rendering the data. The actual measurements are therefore performed on geometrical features, e.g. diameters, planes, without transformation of voxel data to surface data [5]. The CT model is then aligned with the CAD model using a best fit method (see example applied on the pipe connector in fig. 7). The alignment is run five times to ensure a stable fit result. Then, the “CMM” program is run and results are obtained.

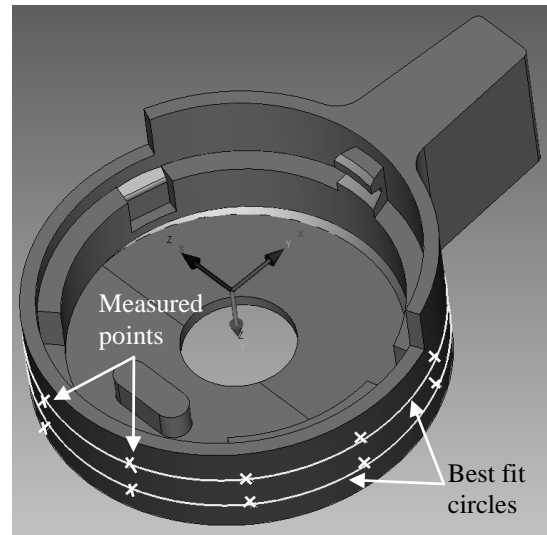

Fig.6. Definition of measurands by selecting features on the CAD model in Calypso CT software. Two best fit circles are defined on the outer part of the toggle by equally distributed measuring points around the circumference.

Measuring strategies for the toggle:

- Diameter ( $D_T$ ): a) **Circle:** measurements at two levels (at 0.5 mm and 1.0 mm from reference plane); b) **Spiral**; c) **Recall:** Recalls previously created features (in our case two circles).
- Diameter ( $d_T$ ): **Circle:** measurement at a level with the smallest diameter (this is due to the poor quality the hole where measurement was taken) by fitting a circle.
- Height ( $H_T$ ): a) **Plane - Plane:** fitting of planes (plane in Calypso CT is defined by creating a poly-line with specified amount of points) on the top surface of the pillar and on

the surface in the vicinity of the pillar; b) **Point - Plane**: three points are randomly selected on the top surface of the pillar and a plane is fitted on the surface in the vicinity of the pillar.

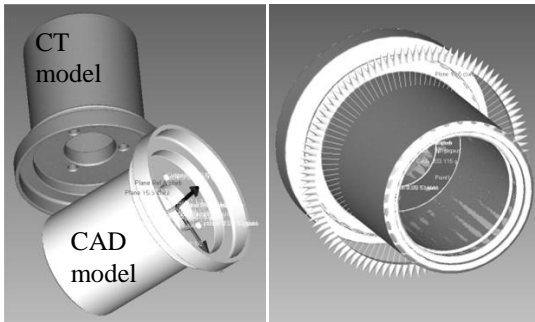

Fig.7. Registration of the CT voxel model with the CAD model. The registration is run five times before it is finished.

Measuring strategies for the pipe connector:

- Diameter ( $d_p$ ): a) **Circle**: measurements at three levels (at 15, 25 and 35 mm from reference plane); b) **Spiral**; c) **Recall**: Recalls previously created features (in our case three circles).
- Angle ( $\alpha_T$ ): **Circle based**.
- Distance ( $L_p$ ): a) **Plane - Plane**: fitting of planes on both parallel surfaces; b) **Point - Plane**: three points are randomly selected on the surface of the flange (each of the points is defined in between two holes of diameter 3.5mm) and a plane is fitted on the surface on the opposite side.

### 5.2. VGStudio MAX

Measurements in VGStudio MAX are performed, once the original CT model is saved in Calypso CT as a volume data. Then, the definition of measurands is done directly on a volume model.

Measuring strategies for the toggle:

- Diameter ( $D_T$ ): a) **Circle**: the same strategy as in Calypso CT; b) **Feature fit**; c) **Cylinder circle**: the selection of points is realized in between two levels, at 0.5 mm and 1.0 mm from reference plane.
- Diameter ( $d_T$ ): the same strategy as in Calypso CT (see fig.8).
- Height ( $H_T$ ): the same strategies as in Calypso CT (see fig.9).

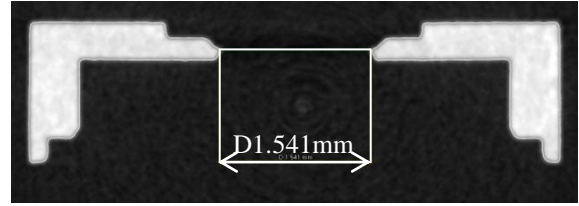

Fig.8. Measurement of  $d_T = 1.55$  mm in the cross-sectional view in VGStudio MAX software.

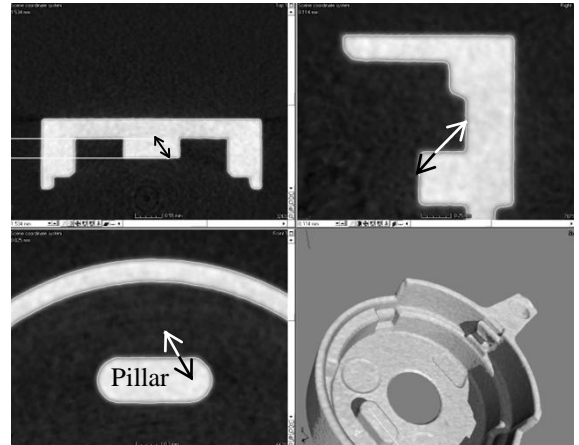

Fig.9. Selection areas for height measurements on the toggle. The arrow indicates positions where the actual measurement of pillar height was taken. The height is measured by projecting fitted points from the top surface of the pillar down on the fitted surface around the pillar.

Measuring strategies for the pipe connector:

- Diameter ( $d_p$ ): a) **Circle**: the same strategy as in Calypso CT; b) **Feature fit**; c) **Cylinder circle**: the selection of points is realized in between two levels, at 15 mm and 35 mm from reference plane.
- Angle ( $\alpha_T$ ): a) **Circle based**; b) **Cylinder based**.
- Distance ( $L_p$ ): the same strategies as in Calypso CT.

### 5.3. ATOS

An STL file is imported into ATOS, after it was exported from the original volume data in Calypso CT.

Measuring strategies for the toggle:

- Diameter ( $D_T$ ): the same strategies as in VGStudio MAX.
- Diameter ( $d_T$ ): the same strategy as in Calypso CT.
- Height ( $H_T$ ): the same strategies as in Calypso CT.

Measuring strategies for the pipe connector:

- Diameter ( $d_p$ ): the same strategies as in VGStudio MAX.
- Angle ( $\alpha_T$ ): the same strategies as in VGStudio MAX.
- Distance ( $L_p$ ): the same measuring strategies as in Calypso CT.

## 6. RESULTS AND DISCUSSIONS

### 6.1. Pipe connector

Results of the uncertainty calculation are presented in fig. 10 - 14 and are summarized in Table 4. Table 4 also presents calculation of the bias, which was however not taken into consideration for uncertainty assessment. The dashed lines in the graphs show uncertainties which were obtained through the reference measurements, calculated according to Equation 2. Generally, one can observe that bigger uncertainties are associated with measurements in ATOS. Uncertainty contributor connected to the reproducibility of scanning is a dominating contributor for calculation of expanded combined uncertainty. Big uncertainties are also linked with the bias, which is highlighted in Table 4. The bias is not small, especially for measurements in ATOS, and if one does not correct for systematic effect and add this contributor to the uncertainty, as it is possible to do so according to [7], the uncertainty would in our case increase rapidly.

One of the reasons for bigger uncertainties and bigger bias values calculated and measured in ATOS software may be the fact that measurements in ATOS were done on a polygonal mesh. The surface accuracy is in general connected to the number of triangles used to approximate the surface. This is further connected to the existence of noise which is present at some parts of the volume model. The presence of noise is most likely due to bigger length which the X-rays travel through the aluminum matter. This is a common problem when using CT scanning. To eliminate this noise, it is always advisable to position the workpiece on the rotary table so that the length the X-rays travel through the matter is minimized. To avoid image artefacts, like beam hardening, it is also important to minimize the radiographic length through the object [8]. The bigger is the length, the more X-rays are attenuated (absorbed by the matter and scattered) and therefore smaller amount of X-rays is detected on the X-ray detector, resulting in worsened quality of the projection and thereafter of the whole 3D voxel model. Our part was positioned at approximately  $45^\circ$ ; however the length was big enough to cause noise. Generally,

STL data is very sensitive regarding image noise. So, when a polygonal mesh (triangles) is created on the voxel model with noise, this noise will then become a part of the mesh (see fig. 15).

For diameter measurements the uncertainties calculated in Calypso CT and VGStudio MAX are low and in good agreement with uncertainties from reference measurements. This is probably due to more robust fitting algorithms for diameter evaluation (fig. 10) rather than for measurements of distance between planes (fig. 12) and the presence of noise is more sensitive for bidirectional measurement. Uncertainties from ATOS are approximately twice bigger compared to uncertainties obtained in Calypso CT and VGStudio MAX, which only confirms the problematic concerning measurements on the polygonal mesh. Figure 11 shows result of angle measurement between couple of holes. Here again, uncertainties calculated for measurements in Calypso CT and VGStudio MAX are smaller by factor of three compared to measurements in ATOS software. Uncertainties related to geometrical tolerances (cylindricity and parallelism) result in random manner in different software and it is therefore difficult to give a clear explanation. High values are associated with scanning and measuring reproducibility.

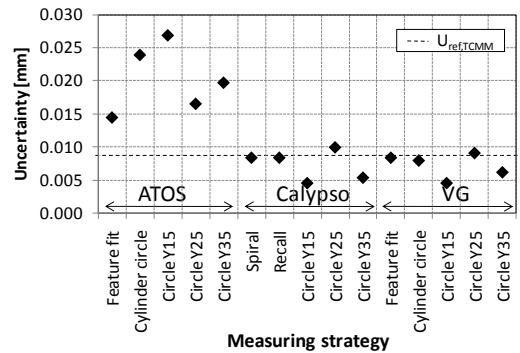

Fig.10. Expanded combined uncertainties for diameter measurement ( $d_p$ ) performed on the pipe connector.



Table 4. Uncertainty results for the pipe connector. All values for dimensions and geometrical tolerances are in mm, angle is in °.

PIPE CONNECTOR		ATOS				CALYPSO CT				VGSTUDIO MAX			
		$u_{ref}$	$u_p$	$b$	$U$	$u_{cal}$	$u_p$	$b$	$U$	$u_{cal}$	$u_p$	$b$	$U$
$D_p$	Feature fit	0.004	0.006	-0.015	0.014					0.004	0.002	-0.002	0.008
	Cylinder circle	0.004	0.011	-0.010	0.024					0.004	0.001	-0.002	0.008
	Spiral					0.004	0.002	-0.001	0.008				
	Recall					0.004	0.002	0.000	0.008				
$L_p$	Plane-Plane	0.000	0.019	0.027	0.038	0.000	0.005	-0.004	0.011	0.000	0.004	-0.004	0.009
	P1-Plane	0.000	0.014	0.029	0.028	0.000	0.008	0.000	0.017	0.000	0.009	0.002	0.019
	P2-Plane	0.000	0.021	0.029	0.043	0.000	0.008	-0.003	0.017	0.000	0.005	-0.005	0.011
	P3-Plane	0.000	0.016	0.016	0.032	0.000	0.009	-0.009	0.019	0.000	0.010	-0.006	0.020
$\alpha_p$	Cylinder 1-2	0.013	0.175	0.140	0.350					0.013	0.020	0.250	0.048
	Cylinder 2-3	0.004	0.192	0.227	0.385					0.004	0.008	0.120	0.018
	Cylinder 1-3	0.015	0.019	-0.368	0.048					0.015	0.015	-0.371	0.043
	Circle 1-2	0.007	0.239	0.232	0.478	0.007	0.010	0.298	0.024	0.007	0.035	0.308	0.072
	Circle 2-3	0.008	0.085	0.104	0.171	0.008	0.010	0.139	0.026	0.008	0.020	0.115	0.044
	Circle 1-3	0.003	0.323	-0.336	0.647	0.003	0.010	-0.437	0.021	0.003	0.013	-0.420	0.027
$P_p$		0.002	0.007	0.069	0.015	0.002	0.012	0.037	0.024	0.002	0.020	0.063	0.041
$C_p$	Feature fit	0.002	0.022	0.087	0.043					0.002	0.002	0.030	0.005
	Cylinder circle	0.002	0.030	0.073	0.052					0.002	0.002	0.030	0.005
	Spiral					0.002	0.009	0.048	0.019				
	Recall					0.002	0.001	0.040	0.004				

Uncertainty contributor  $u_c$  is not included in the table as this has no effect on expanded uncertainty and is therefore neglected. Symbols P1, P2 and P3 stand for three randomly selected points on the surface of the inner flange.

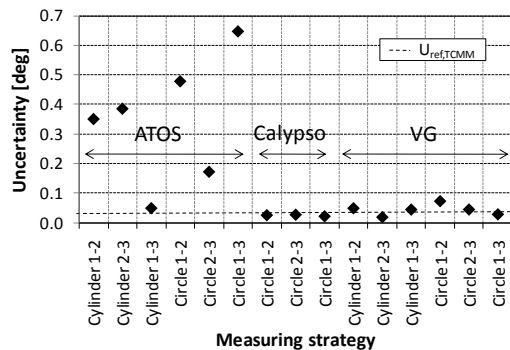

Fig.11. Expanded combined uncertainties for angle measurement ( $\alpha_p$ ) performed on the pipe connector. The numbers behind the strategy (e.g. Cylinder 1-2) represent corresponding couple of holes in between which the angle was measured with respect to the rotational axis of the part.

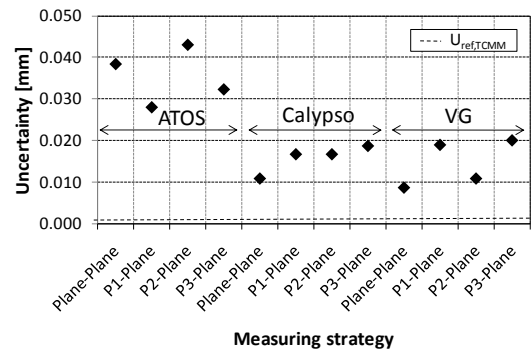

Fig.12. Expanded combined uncertainties for distance ( $L_p$ ) performed on the pipe connector. Symbols P1, P2 and P3 represent three randomly selected points on the surface of the inner flange.

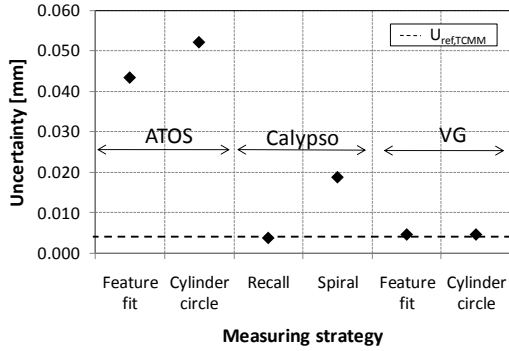

Fig.13. Expanded combined uncertainties for cylindricity ( $C_p$ ) measurement performed on the pipe connector.

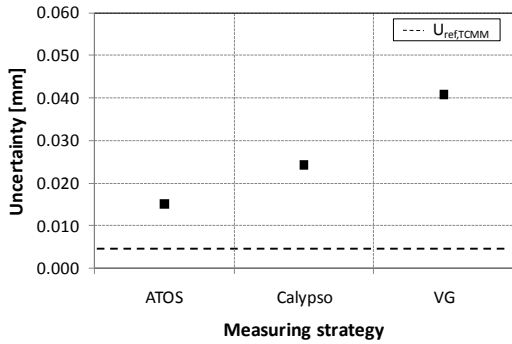

Fig.14. Expanded combined uncertainties for parallelism ( $P_p$ ) measurement performed on the pipe connector.

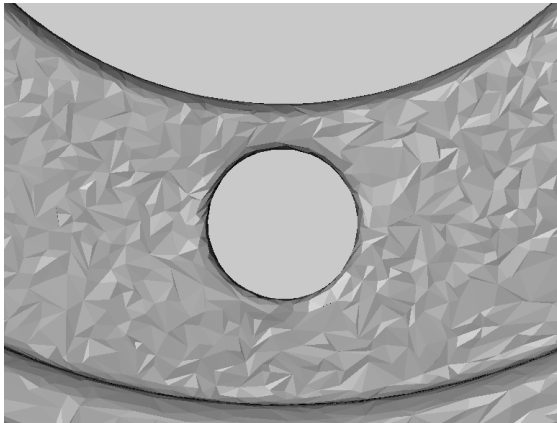

Fig.15. A polygonal mesh (surface from triangles) created out of the voxel data, resulting in many cases in loss of accuracy for dimensional measurement. Particularly image noise leads to a “pseudo” roughness of the surface.

## 6.2. Toggle

Results of the uncertainty calculation are presented in fig. 16 - 19 and are summarized in Table 5. Big bias values can be noticed for measurements of inner diameter  $d_T$ , height of the pillar  $H_T$  and concentricity  $C_T$ , being in the range from 12 to 32  $\mu\text{m}$ . This is the same in all the three

software packages. The situation is however different for measurements of the outer diameter  $D_T$ , where maximum bias value is 4  $\mu\text{m}$  for measurements in ATOS (see fig. 16). Small bias values for outer diameter measurements on the toggle are in agreement with measurements of the pipe connector as discussed in section 6.1. Uncertainties obtained from measurements in all software packages are low and in good agreement with uncertainties from reference measurements.

Uncertainties from measurements of the inner diameter  $d_T$  are low for measurements in ATOS and Calypso CT and are in the same range as calibration uncertainty (see fig. 17). On the other hand uncertainty calculated in VG software is big which may be due to difficulties with measurements of poor quality hole edge, as is shown in fig. 8. Measurement of diameter  $d_T$  was done in different ways with respect to the software packages. It can be noticed from Table 5 that all CT measures are found bigger than reference values (positive bias values), resulting in possible instability of the polymeric micro part due to time elapsed from the last reference measurements.

Results of height measurement of the pillar are similar for all three software packages (see fig. 18). The main uncertainty contributor is in this case from the reference instrument. It is shown that both measuring strategies applied for height measurement (Plane – Plane and Point - Plane) are comparable being in the same range as calibration uncertainty. Some uncertainty values are however bigger for Point – Plane measuring strategy. This behavior is quite obvious because the selected single points on the surface may be some outliers of the volume data set.

High scanning and measuring reproducibility is generally obtained for the toggle.

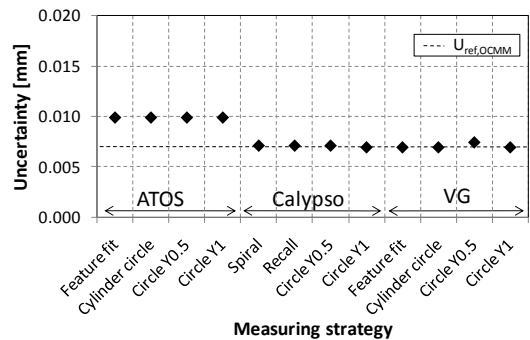

Fig.16. Expanded combined uncertainties for diameter measurement ( $D_T$ ) performed on the toggle.

Table 5. Uncertainty results for the toggle. All values are in mm.

TOGGLE		ATOS				CALYPSO CT				VGSTUDIO MAX			
		$u_{ref}$	$u_p$	$b$	$U$	$u_{cal}$	$u_p$	$b$	$U$	$u_{cal}$	$u_p$	$b$	$U$
$D_T$	Feature fit	0.003	0.004	0.004	0.010					0.003	0.000	0.001	0.007
	Cylinder circle	0.004	0.004	-0.007	0.010					0.003	0.000	-0.001	0.007
	Spiral					0.003	0.001	0.001	0.007				
	Recall					0.003	0.001	0.000	0.007				
$d_T$	Circle	0.002	0.003	0.032	0.008	0.002	0.001	0.030	0.005	0.002	0.010	0.013	0.020
$H_T$	Plane-Plane	0.005	0.001	-0.015	0.010	0.005	0.003	-0.017	0.011	0.005	0.000	-0.013	0.010
	P1-Plane	0.005	0.002	-0.015	0.011	0.005	0.004	-0.019	0.013	0.005	0.000	-0.014	0.010
	P2-Plane	0.005	0.003	-0.014	0.011	0.005	0.006	-0.020	0.016	0.005	0.002	-0.012	0.010
	P3-Plane	0.005	0.002	-0.013	0.011	0.005	0.005	-0.017	0.014	0.005	0.001	-0.014	0.010
$C_T$	Feature fit	0.002	0.006	0.016	0.012					0.004	0.004	0.016	0.011
	Cylinder circle									0.002	0.004	0.014	0.008
	Spiral					0.002	0.000	0.016	0.003				
	Recall					0.002	0.001	0.015	0.004				

Uncertainty contributor  $u_e$  is not included in the table as this has no effect on expanded uncertainty and is therefore neglected.

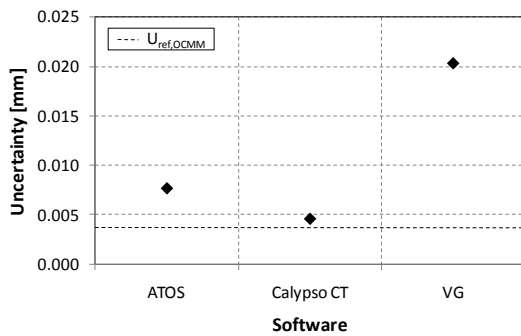

Fig.17. Expanded combined uncertainties for diameter measurement ( $d_T$ ) performed on the toggle.

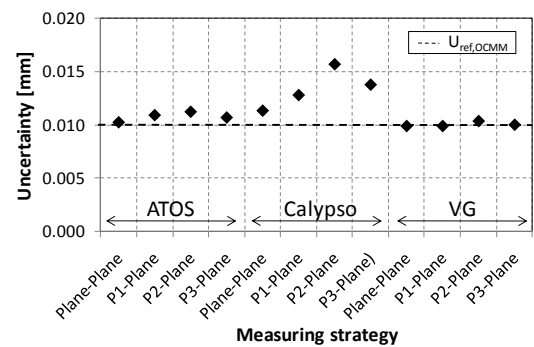

Fig.18. Expanded combined uncertainties for height measurement ( $H_T$ ) performed on the toggle. Symbols P1, P2 and P3 represent three randomly selected points on the top surface of the pillar.

## 7. CONCLUSIONS

This paper evaluates measuring results obtained by CT scanning using different measuring strategies applied in different inspection software. The strategy influence is determined by calculating the measuring uncertainty. Two industrial parts were measured, an aluminum pipe connector and a plastic toggle, a hearing aid component. These items are measured using a CT scanner and compared with measurements on tactile CMM and optical CMM. Some conclusions from this investigation can be drawn:

- Diameter measurements of cylindrical features for both aluminum and plastic parts resulted in small bias (difference between measurements using CT scanner and reference instruments) compared to distance and height measurements. This was due to a robust fitting algorithm and well defined geometrical features.
- Bias values calculated for measurements in ATOS for the pipe connector were generally bigger compared to measurements in Calypso

CT and VGStudio MAX. Bias values of all measurands for the toggle were in the same range for all the three software.

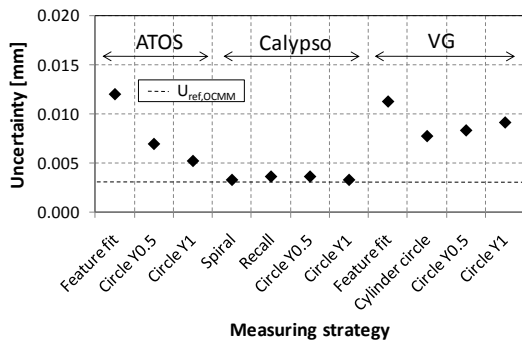

Fig.19. Expanded combined uncertainties for concentricity measurement ( $C_T$ ) performed on the toggle.

- The same was for uncertainties calculated for measurements in ATOS for the pipe connector which were generally bigger compared to uncertainties obtained for measurements in Calypso CT and VGStudio MAX. Uncertainties of all measurands for the toggle were found in the range of calibration uncertainties and not bigger than 16  $\mu\text{m}$  in all the three software.
- Uncertainties connected with measurement of the distance between two surfaces on the inner flange of the pipe connector from CT scanner were found bigger compared to uncertainties obtained from reference measurements performed on tactile CMM. On the other hand, uncertainties for measurements of the pillar height on the toggle from CT scanner were found to be in the same range as uncertainties obtained from reference measurements performed on optical CMM. This can be directly connected with the reference instrument itself, since tactile CMMs are more accurate compared to optical machines. Other reason can be the existence of the noise when scanning aluminum part which occurs due to the thickness of material and consequent absorption of X-rays or due to beam hardening artefacts.
- By CT scanning a part with high density of points is obtained. This is one of the biggest advantages when using CT scanning compared to other measuring techniques. Special inspection softwares are developed to handle these CT data sets (both volume and surface) enabling to fit geometrical primitives like cylinders, planes, etc. on the

reconstructed 3D models and calculate the desired geometrical feature. VGStudio MAX (volume model) and ATOS (STL model) have the possibility to fit geometrical primitives on the volume/STL model compared to Calypso CT, where other fitting algorithms are used.

- In the case of a presence of image noise on the CT data set, one can filter these data before applying the surface (STL). One should however be careful since this may lead to degradation of the original data set and therefore significantly change shape of a part and therefore obtain different measuring result. Another possibility how to avoid noise is to change the scanning parameters (e.g. integration time, current), which is in many cases rather difficult task.

## ACKNOWLEDGEMENT

This paper discusses investigation which was undertaken in the context of the Danish project “CIA-CT – Center for Industrial Application of CT scanning”. The authors would like to thank Danish Technological Institut for kindly providing the CT scanner, namely to Mr. Peder Pedersen for making the scans. Novo Nordisk A/S is acknowledged for kindly providing use of one of the software. Thanks to Mr. Jakob Rasmussen (Technical University of Denmark) in connection with CMM measurements

## REFERENCES

- [1] Bartscher, M., Hilpert, U., Goebbels, J. and Weidemann, G. (2007). Enhancement and Proof of Accuracy of Industrial Computed Tomography (CT) Measurements, *Annals of CIRP*, Vol. 56/1, pp. 495-498.
- [2] Bartscher, M. Neukamm, M., Hilpert, U., Neuschaefer-Rube, U., Härtig, F., Kniel, K., Ehrig, K., Staude, A. and Goebbels, J. (2010). Achieving traceability of industrial computed tomography, *Key Engineering Materials*, Vol. 437, pp. 79-83.
- [3] Bergmann, R.B., Bessler, F.T. and Bauer, W. (2004). Computer tomography for nondestructive testing in the automotive industry, *Proceedings of SPIE*, Vol. 5535/1, pp. 464-472.
- [4] Gasparin, S., Tosello, G., Hansen, H.N. and Jørgensen, M.B. (2009). Quality control of injection moulded micro mechanical parts, *Proceedings of the 5th International*

- Conference on Multi-Material Micro Manufacture (4M/ICOMM 2009)*, pp. 175-178.
- [5] Heinzl, Ch., Kastner, J., Georgi, B. and Lettenbauer, H. (2007). Comparison of surface detection methods to evaluate cone beam computed tomography data for three dimensional metrology, *International Symposium on Digital industrial Radiology and Computed Tomography*.
- [6] Hilpert, U., Bartscher, M., Neugebauer, M., Goebbels, J., Weidemann, G. and Bellon, C. (2007). Simulation-aided computed tomography (CT) for dimensional measurements, *International Symposium on Digital industrial Radiology and Computed Tomography*.
- [7] ISO/IEC Guide 98-3:2008 - Uncertainty of measurement -- Part 3: Guide to the expression of uncertainty in measurement (GUM:1995).
- [8] Kruth, J.P., Bartscher, M., Carmignato, S., Schmitt, R., De Chiffre, L. and Weckenmann, A. (2011). Computed Tomography for Dimensional Metrology, *CIRP Annals – Manufacturing Technology*, **Vol. 60/2** (In Press).
- [9] Müller, P., Pacurar, R.A., De Chiffre, L., Cantatore, A. and Berce, P. (2011). Geometrical metrology on silicone rubber by computed tomography, *Proceedings of 11th euspen International Conference*, pp. 243-246.
- [10] Reinhart, Ch., (2008). Industrial computer tomography – a universal inspection tool, *17th World Conference on Nondestructive Testing*.
- [11] Schmitt, R. and Niggemann, Ch. (2010). Uncertainty in measurement for x-ray-computed tomography using calibrated workpieces, *Measurement Science and Technology*, **Vol. 21**, pp. 1-9.
- [12] Tosello, G., Hansen, H.N. and Gasparin, S. (2009). Applications of dimensional micro metrology to the product and process quality control in manufacturing of precision polymer micro components, *CIRP Annals – Manufacturing Technology*, **Vol. 58**, pp. 467-472.
- [13] Weckenmann, A. and Krämer, P. (2009). Predetermination of measurement uncertainty in the application of computed tomography, *11th CIRP International Conference on Computer Aided Tolerancing*.
- [14] Welkenhuyzen, F., Kiekens, K., Pierlet, M., Dewulf, W., Bleys, P., Kruth, J.P. and Voet, A. (2009). Industrial Computer Tomography for Dimensional Metrology: Overview of Influence Factors and Improvement Strategies, *4th International Conference on Optical Measurement Techniques for Structures and Systems (OPTIMESS2009)*.
- [15] Wenig, P. and Kasperl, S. (2006). Examination of the Measurement Uncertainty on Dimensional Measurements by X-ray Computed Tomography, *Proceedings of 9th European Congress on Non-Destructive Testing (ECNDT 2006)*.