



University of Warwick institutional repository: <http://go.warwick.ac.uk/wrap>

This paper is made available online in accordance with publisher policies. Please scroll down to view the document itself. Please refer to the repository record for this item and our policy information available from the repository home page for further information.

To see the final version of this paper please visit the publisher's website. Access to the published version may require a subscription.

Author(s): Z. Tamainot-Telto, , S.J. Metcalf, R.E. Critoph

Article Title: Novel compact sorption generators for car air conditioning

Year of publication: 2009

Link to published article:

<http://dx.doi.org/10.1016/j.ijrefrig.2008.11.010>

Publisher statement: "NOTICE: this is the author's version of a work that was accepted for publication in International Journal of Refrigeration. Changes resulting from the publishing process, such as peer review, editing, corrections, structural formatting, and other quality control mechanisms may not be reflected in this document. Changes may have been made to this work since it was submitted for publication. A definitive version was subsequently published in International Journal of Refrigeration, [VOL:32, ISSUE:4, June 2009, DOI: 10.1016/j.ijrefrig.2008.11.010"]

Novel compact sorption generators for car air conditioning

Nouveau générateur compact à sorption pour la climatisation automobile

Z. Tamainot-Telto⁽¹⁾, S.J. Metcalf and R.E. Critoph

School of Engineering - University of Warwick

Coventry CV4 7AL – United Kingdom (UK)

Abstract

A prototype compact generator using the activated carbon - ammonia pair based on the plate heat exchanger concept has been designed and built at Warwick University. The novel generator has low thermal mass and good heat transfer. The heat exchanger uses nickel-brazed shims and spacers to create adsorbent layers only 4 mm thick between pairs of liquid flow channels of very low thermal mass. The prototype sorption generator manufactured was evaluated under EU car air conditioning test conditions.

The prototype sorption generator is described and its experimental performance reported. While driven with waste heat from the engine coolant water (at 90°C), a pair of the current prototype generators (loaded with about 1 kg of activated carbon) operating out of phase has produced an average cooling power 1.6 kW with about 2 kW peaks. The typical average COP obtained is 0.22.

Keywords: Activated carbon, Air conditioning, Ammonia, COP, Heat exchanger, Generator, Sorption.

Résumé

Un prototype du générateur compact, basé sur le concept des échangeurs de chaleur à plaques et utilisant la paire charbon actif-ammoniac, a été conçu et construit à l'Université

⁽¹⁾ Corresponding author: E-mail es2071@eng.warwick.ac.uk - Tel. +44 24 76522108 – Fax +44 24 76418922

de Warwick. Le nouveau générateur a une faible inertie thermique et un excellent transfert de chaleur. L' échangeur utilise des plaques ayant des micro-canaux et des intercalaires brasés au Nickel pour créer des couches d'adsorbant de 4 mm d'épaisseur entre les paires de plaques à l'intérieur desquelles circule le fluide liquide. Le prototype du générateur à sorption ainsi fabriqué a été testé suivant des conditions prescrites par la Norme Européenne de la Climatisation Automobile.

Le prototype du générateur à sorption est décrit et ses performances expérimentales présentées. Une paire dudit prototype (contenant chacun 1 kg de charbon actif), opérant avec déphasage et utilisant des pertes thermiques en provenance de l'eau de refroidissement de moteur (à 90°C), a produit une puissance frigorifique moyenne de 1.6 kW avec une valeur maximum de 2 kW. La valeur typique du COP moyen est de l'ordre de 0.22.

Mot clés: Charbon actif, Conditionnement d'air, Ammoniac, COP, Echangeur de chaleur, Générateur, Sorption.

Nomenclature

Abbreviations

COP	Coefficient of performance in cooling
MACS	Mobile air conditioning system
NH ₃	Ammoniac
PLATEX	Plate type heat exchanger
SCP	Specific cooling power
SOPLATEX	Sorption plate heat exchanger

Symbols

A	Surface area (m ²)
K-value	Flow rate corresponding to a pressure drop of 1 bar (m ³ h ⁻¹)

MACS Mobile Air Conditioning System

T Temperature ($^{\circ}\text{C}$)

TEV Thermostatic expansion valve

U Overall heat transfer coefficient ($\text{W m}^{-2}\text{K}^{-1}$)

Subscripts

A Adsorption

C Condensation, Condenser

E Evaporation, Evaporator

G Generation, Generator

Introduction

In 2005, the first experimental prototype of a compact generator using the monolithic carbon-ammonia pair was developed at Warwick University. The compact generator was based on the concept of a plate heat exchanger (PLATEX) as illustrated in **Figure 1**. The main objectives were to demonstrate the manufacturing feasibility of a compact generator based on PLATEX and to evaluate its thermal performance when mounted on a full cooling machine. The mechanical and thermal behaviour of the prototype were satisfactory but the cooling performance obtained ($SCP \sim 0.150 \text{ kW kg}^{-1}$ carbon and $COP \sim 0.120$) were poor but predicted well by a theoretical model [1]. The performance limitations were mainly due to the design and manufacturing process of the prototype [2]. Design improvements were later carried out on the configuration, reducing the thermal mass and enhancing the heat transfer [3]. A new manufacturing process for a fully welded compact generator that withstands both high pressure (up to 30 bar) and high temperature (up to 200°C) is now established.

Novel sorption generator

The novel sorption generator is a nickel-brazed stainless steel design with 29 layers of active carbon adsorbent each 4 mm thick. By incorporating the carbon adsorbent in thin layers, conduction path lengths through the material are reduced and the area for fluid heat transfer is increased which enables rapid temperature cycling and thus a high SCP. The separating stainless steel plates are constructed from chemically etched shims with 0.5 mm square water flow channels on a 1 mm pitch. These channels give a high heat transfer coefficient and a large heat transfer area, further improving heat transfer performance. The square design ensures equal flow path lengths in every channel and therefore even heating and cooling of the adsorbent. The internal pressure (up to 20 bar when condensing at 50°C) is withheld by the stainless steel shims which act as supporting webs to the outer wall, which only needs to

be 3 mm thick despite being straight. The open end of the front face as shown in **Figure 2** is used to insert and remove the adsorbent in order that a range of adsorbents can be tested. **Figure 3** shows both a conceptual drawing and a photograph of the unit fitted with water manifolds and pressure flanges prior to testing. The top and bottom ‘ammonia flanges’ are necessary due to the open face and would be unnecessary in an eventual completely enclosed unit. The end pressure flanges are necessary to prevent deformation of the ends of the unit, but could be replaced by lighter domed ends.

After a preliminary test designed to evaluate the heat transfer performance, the full characteristics of the generator were established and are summarized in **Table 1**.

Laboratory cooling system description

The laboratory cooling system is designed to simulate a mobile air conditioning system (MACS) for a Class C passenger vehicle (such as a Ford Focus or Fiat Bravo) with a 1.9 litre turbo diesel engine. This choice is very challenging due to the high engine efficiency and therefore low waste heat availability. The engine coolant is to be used to provide the heat input at a temperature of 90°C and a nominal flow rate of 24 litre min⁻¹. The cooling power required has been determined from collaboration between two of the project partners, Energy Research Centre of the Netherlands (ECN) and Centro Ricerche Fiat (CRF), to be 2 kW and, although it is highly variable during the driving cycle, the nominal heat input available is 5 kW - thereby necessitating a nominal COP 0.4. A schematic diagram of the system is shown in **Figure 4**. The engine coolant is alternately passed through the two generator beds in order to heat them. A second pumped coolant loop is used to recover heat between the two beds. An air-to-water heat exchanger placed in front of the vehicle radiator (labelled adsorption heat exchanger) is used to cool the generator beds to ambient temperature. An interconnecting pipe with a valve is also incorporated which enables the ammonia side of the

two generators to be connected for mass recovery purposes. In this process, the heated high pressure bed is connected to the cooled low pressure bed and ammonia is transferred from the high pressure to the low. This increases the concentration change in the adsorbent during the cycle, thereby increasing SCP and COP. Check valves are used to control the flow of ammonia between the generators and the condenser and evaporator, which are as per a conventional system. One key difference however is the use of an indirect evaporator with an intermediate chilled water glycol loop – this prevents leakage of toxic ammonia into the cabin, which could occur with a direct evaporator. **Figure 5** and **Figure 6** show photographs of various views of the laboratory scale MACS. For the purposes of controlling both the condensing and evaporating temperatures during the experimental tests, an indirect condenser (ammonia/water) and a temperature controlled bath linked to the evaporator (ammonia/water) are utilised.

Experimental results and discussions

Test were carried out under the Normal European Summer Conditions that are summarized in **Table 2**. With an operating driving temperature of 80°C and 1.3 m³/h flow on each coolant (source and sink) and with mass recovery, the system met the cooling power target: 1.3 kW vs. 1.2 kW target. However the COP was below the target: 0.23 vs. 0.52. The cooling power achieved corresponds to a power density (the cooling power per unit volume) of 93 W/litre based on generator volume and 62 W/litre based on the total system volume. The specific cooling power (the cooling power per unit mass of carbon) SCP is about 0.650 kW kg⁻¹. With increased driving temperature up to 90°C, the cooling power increased to 1.6 kW (**Figure 7**), exceeding the 1.2 kW target by 33%. The COP was 0.22, which is close to the target value of 0.24. The decreased COP obtained with higher driving temperature is due to the fact that the cycle time was not optimised for each condition. The power density was 114 W/litre based on

generator volume and 77 W litre^{-1} based on total system volume. The SCP is about 0.800 kW kg^{-1} . The effect of coolant flow rates through the generator from 0.46 to $1.25 \text{ m}^3 \text{ h}^{-1}$ is presented in **Figure 8**. It can be seen that the effect of the flow rate on performance over the range tested is minimal. The system should therefore not be significantly affected by the variation in the coolant water flow rate from the engine during the driving cycle.

The current preliminary performance will be improved when operating the system with both mass and heat recovery and with an optimised control strategy (cycle time).

Conclusions

A pair of prototype compact generators using activated carbon - ammonia and a plate heat exchanger concept could be used to drive a MACS. With an operating driving temperature of 90°C and about $1.3 \text{ m}^3/\text{h}$ flow on each coolant (source and sink) and with mass recovery, the system met the cooling power target: 1.6 kW vs. 1.2 kW target (33% excess). The COP was 0.22 , which is close to the target value of 0.24 . However with a lower driving temperature of 80°C , although the machine meets the cooling power target (1.3 kW vs. 1.2 kW target), the COP is still below the specification (0.23 vs. 0.52). The specific cooling power (the cooling power per unit mass of carbon) ranges from about 0.650 kW/kg up to 0.800 kW/kg . Performance improvements are expected when the system operates with an optimised cycle time.

Further developments

A second version of the laboratory MACS prototype, that will include the cabin cooler and a direct condenser (ammonia-air) as illustrated in **Figure 9**, is under construction. The complete chiller unit design is shown in **Figure 10**. The new generators are made with 12 mm slots aimed at reducing the thermal mass (**Figure 11**). However a minimum effective

thermal conductivity of 4 to 5 W m⁻¹K⁻¹ is needed in the bed, to equal the performance of the previous 4 mm slot design. This will be achieved by means of thermal enhancement with aluminium fins or use of a carbon mixture with Expanded Natural Graphite (ENG). The management of the four streams of water (two on the heat source and two on the heat sink), previously achieved by using eight distinct solenoid valves, will be now be carried out by an electrical 8-way valve that has already been developed (**Figure 12**). This 8-way valve operates with a ¼ fast turn and low power electrical actuator (1 second, power rate 26 W under 24 Vdc) and is not permanently powered. It is designed for a maximum operating temperature of 100°C and maximum operating pressure of 6 bar; the K-value on each port is approximately 1 m³ h⁻¹. A CAD picture of the lab package is shown in **Figure 13** with a single fan extractor designed to operate both condenser and cooler: the two pipes located on top are for IN/OUT to the heat source; the two pipes located in front are for IN/OUT to the cabin coil.

This version will also be tested with a TEV (trials ongoing) at the latest stage in order to reflect further the mobile air conditioning application.

Acknowledgements

- This research is supported by the EU-TOPMACS project under the grant TST4-CT-2005-012394.
- The authors express their gratitude to Chemviron Carbons Ltd (Lockett Road, Lancashire WN4 8DE, UK) for the long standing collaboration in developing activated carbon applied to heat pump and refrigeration systems.

References

- 1 R. E. Critoph and S. J. Metcalf, Specific cooling power intensification limits in carbon-ammonia adsorption refrigeration systems, *Applied Thermal Engineering*, 24 (5-6), 661-679 (2004).
- 2 Z. Tamainot-Telto, Compact sorption generator Prototype, *Proc. International Sorption Heat Pump Conference (ISHPC)*, Denver (USA), Paper No.ISHPC-065, 8 pages, (2005)
- 3 R.E. Critoph, Heat Exchanger, *UK Patent Application* No 0617721.6 (2006)
- 4 R.E. Critoph, Z. Tamainot-Telto and S.J. Metcalf, "Carbon-Ammonia adsorption cycle machine plate sorption generator", *Proc. IIR - International Congress of Refrigeration*, Beijing (China), Paper ICR07-B1-622, 8 pages, (2007)

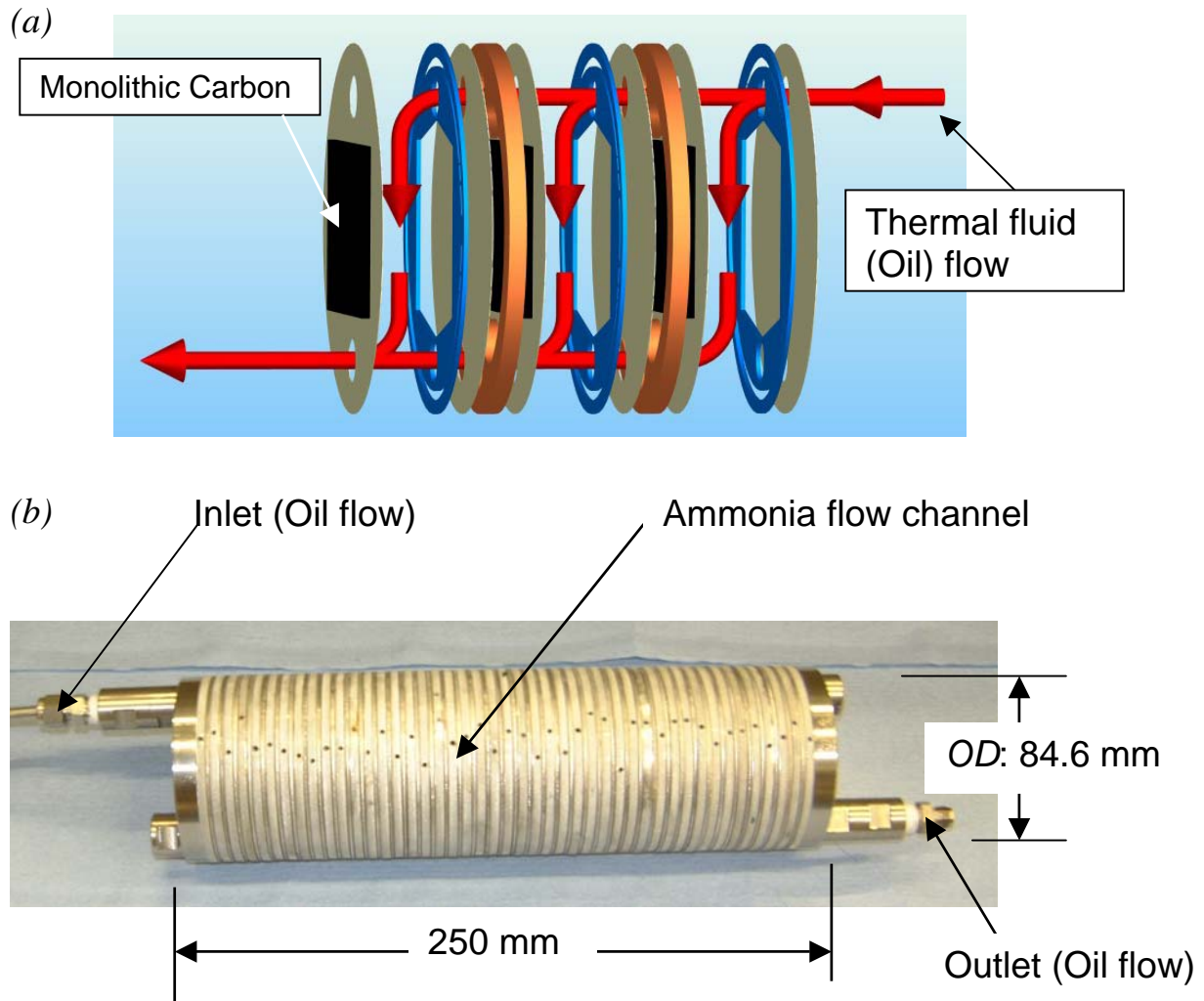

Figure 1: Compact sorption generator – (a) Concept based on plate heat exchanger (PLATEX) – (b) First experimental prototype (SOPLATEX) [2]

Figure 1: Générateur compact à sorption – (a) Concept basé sur l'échangeur de chaleur à plaques (PLATEX) – (b) Premier prototype expérimental (SOPLATEX) [2]

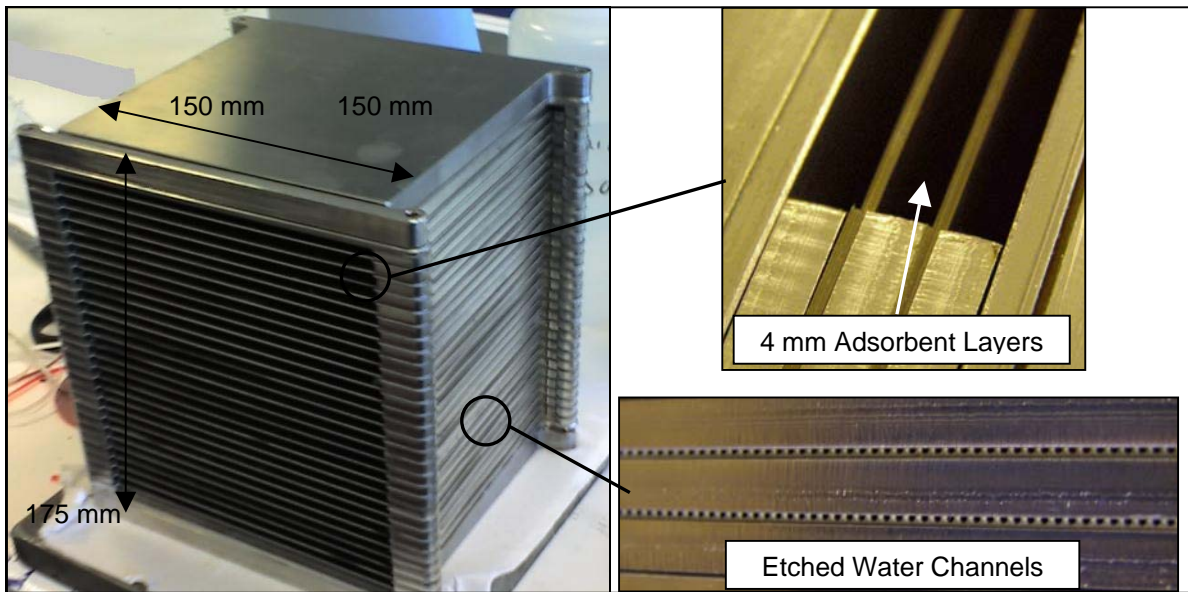

Figure 2: Plate heat exchanger generator design

Figure 2: Design du générateur-échangeur de chaleur à plaques

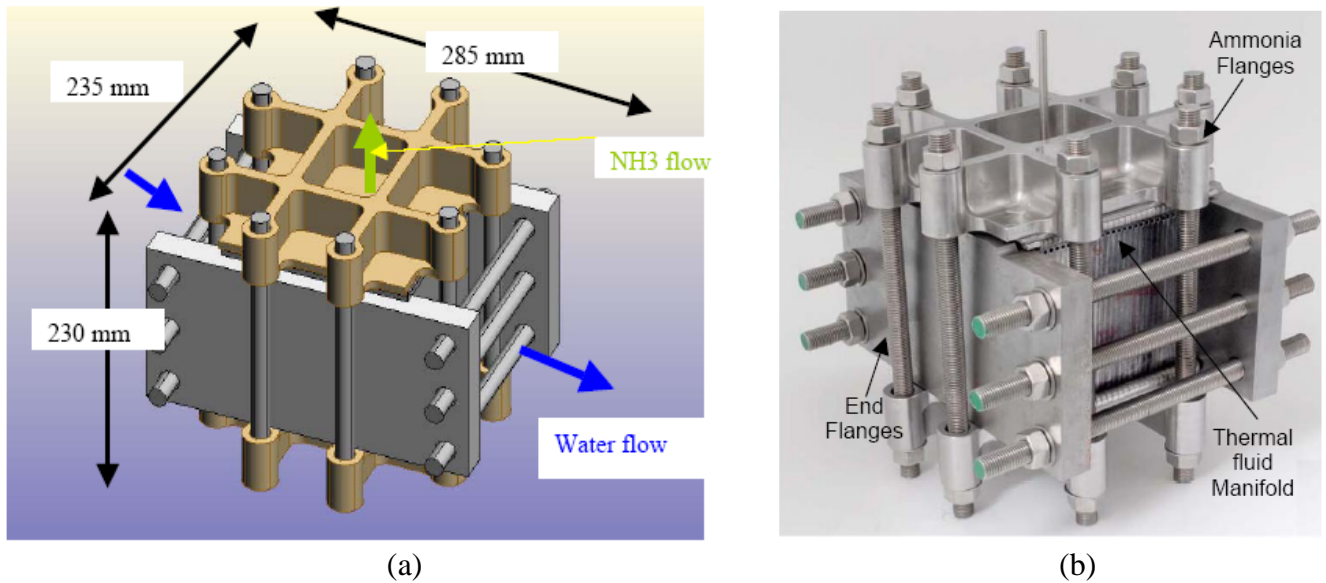

Figure 3: Novel compact sorption generator – (a) Concept design – (b) Experimental prototype

Figure 3: Nouveau générateur compact à sorption – (a) Concept du design – (b) Prototype expérimental

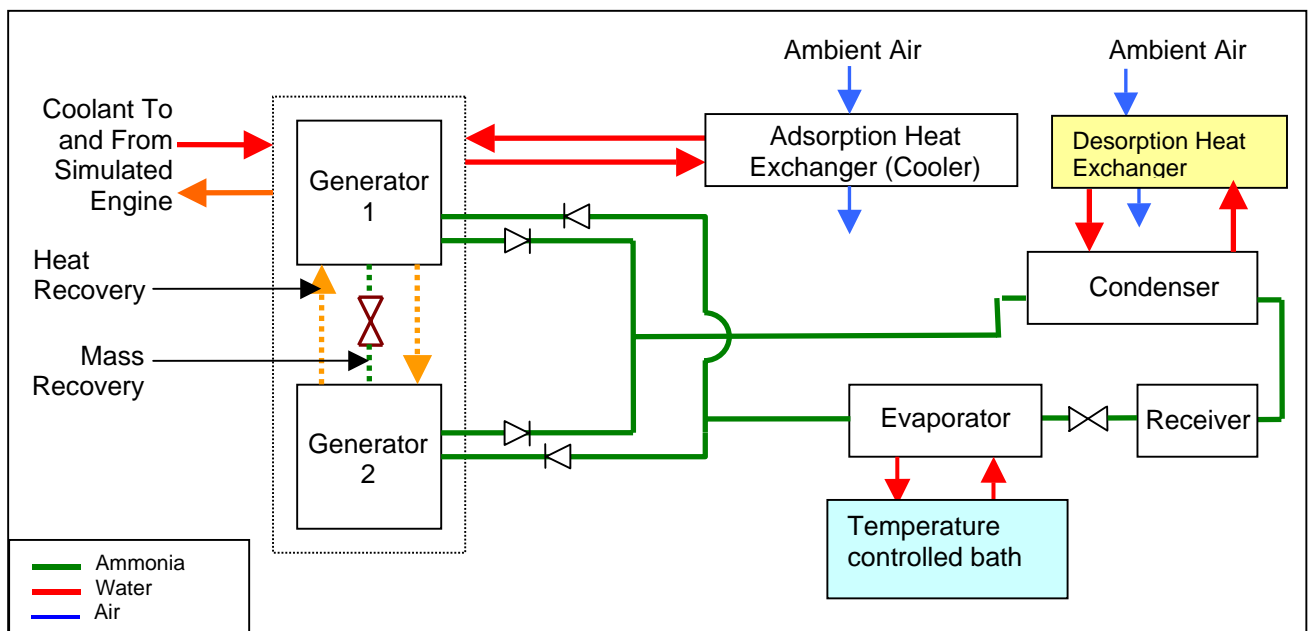

Figure 4: Schematic diagram of Laboratory MACS

Figure 4: Schéma de la MACS en laboratoire

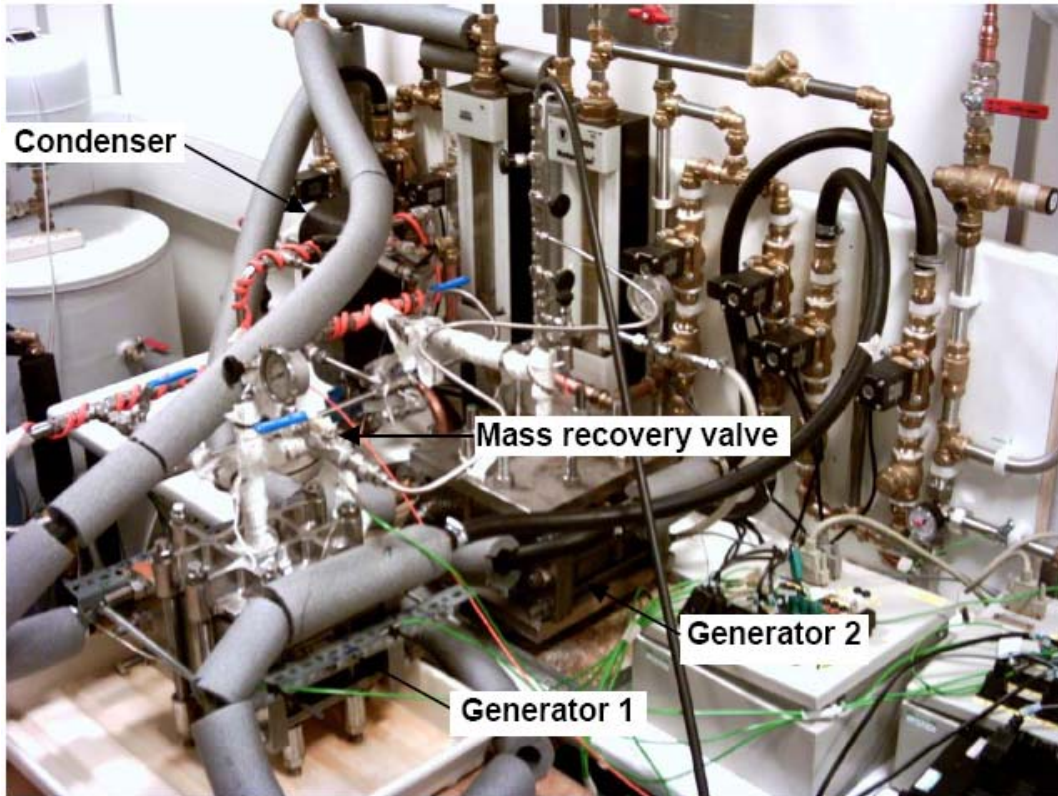

Figure 5: Lab MACS: Generators and condenser view

Figure 5: MACS en laboratoire: vue des générateurs et du condenseur

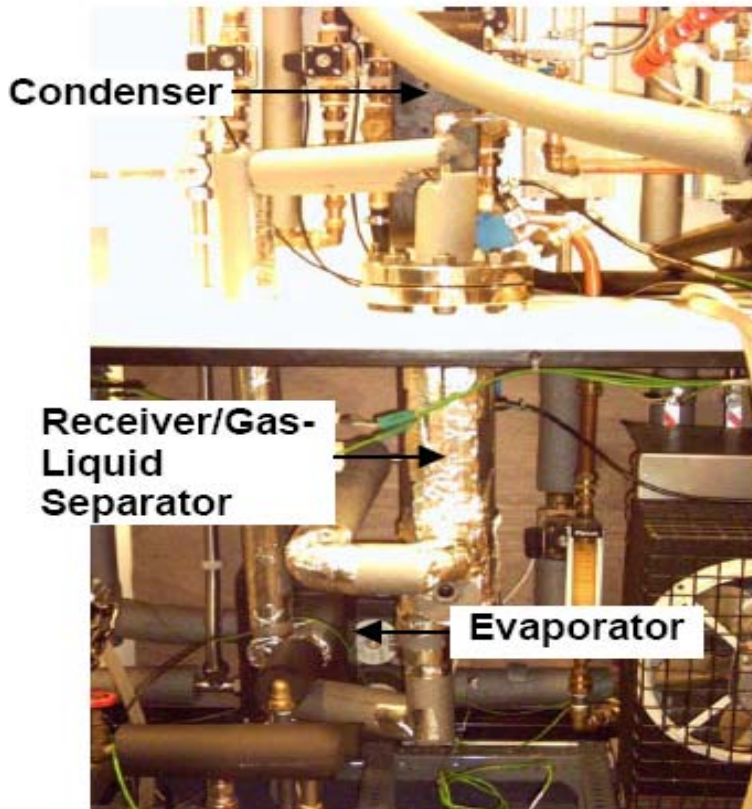

Figure 6: Laboratory MACS: Evaporator and condenser view

Figure 6: MACS en laboratoire: vue de l'évaporateur et du condenseur

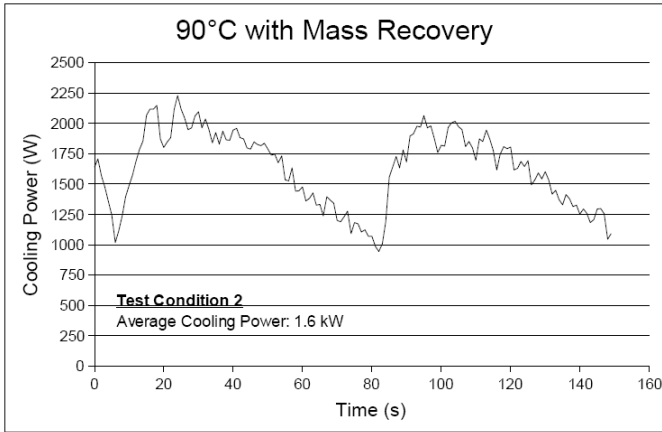

Figure 7: Variation of cooling production
Figure 7: Variation de la production frigorifique

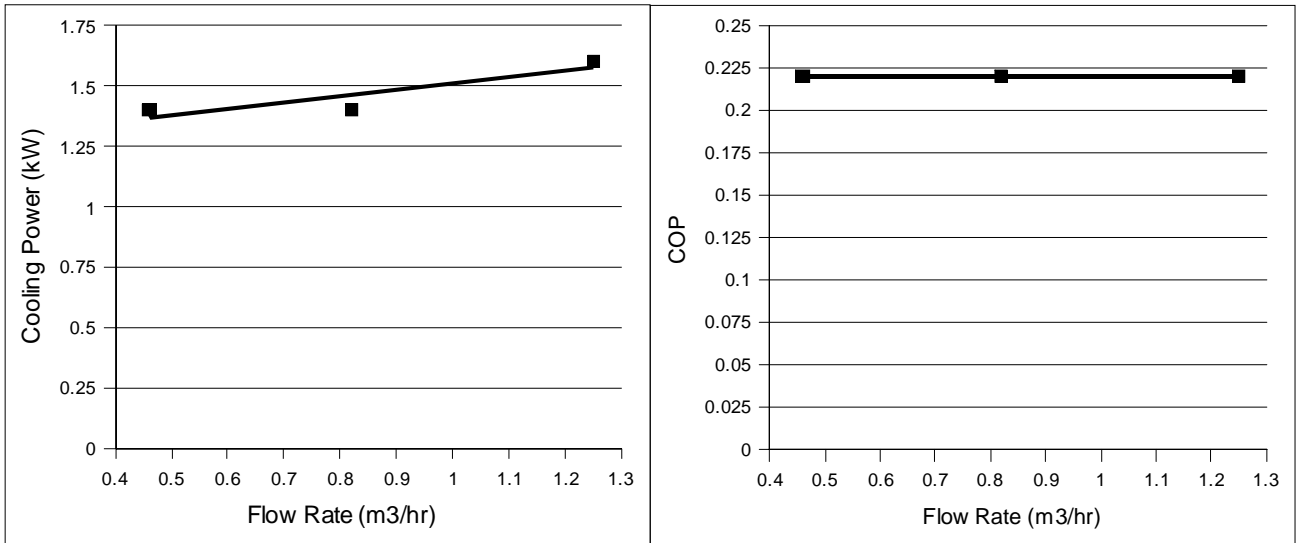

Figure 8: Effect of coolant flow rate on the system performance
Figure 8: Influence du débit d'eau de refroidissement sur les performances du système

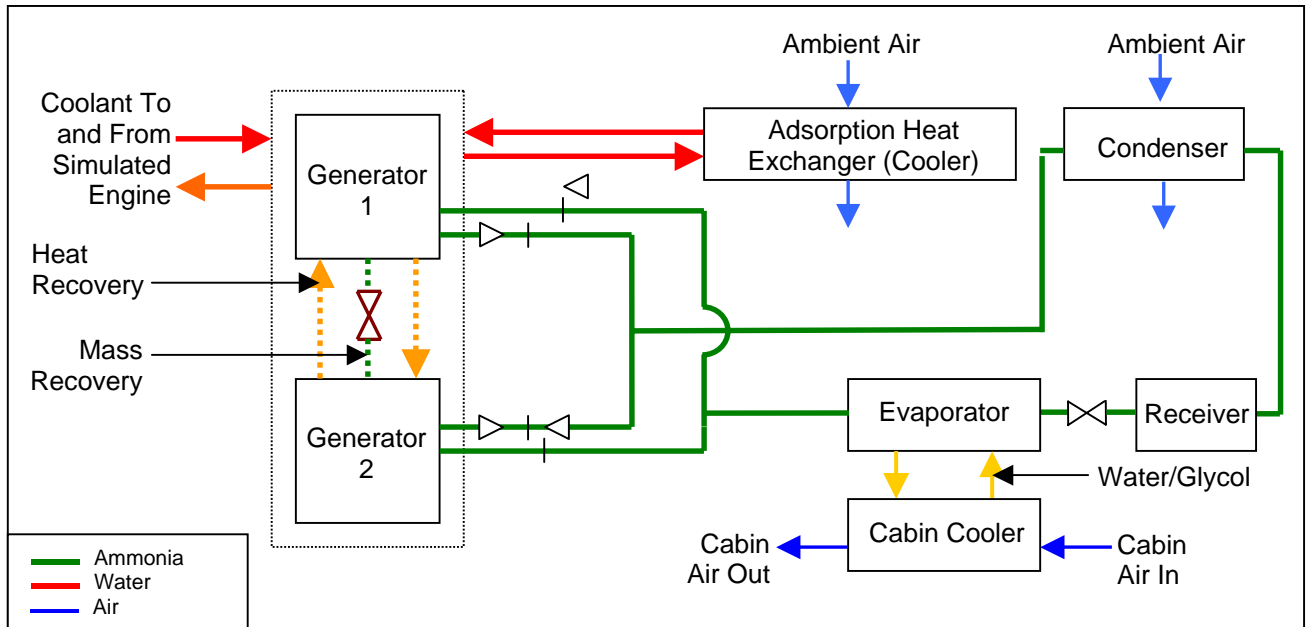

Figure 9: Laboratory MACS – Version 2
Figure 9: MACS en laboratoire – Version 2

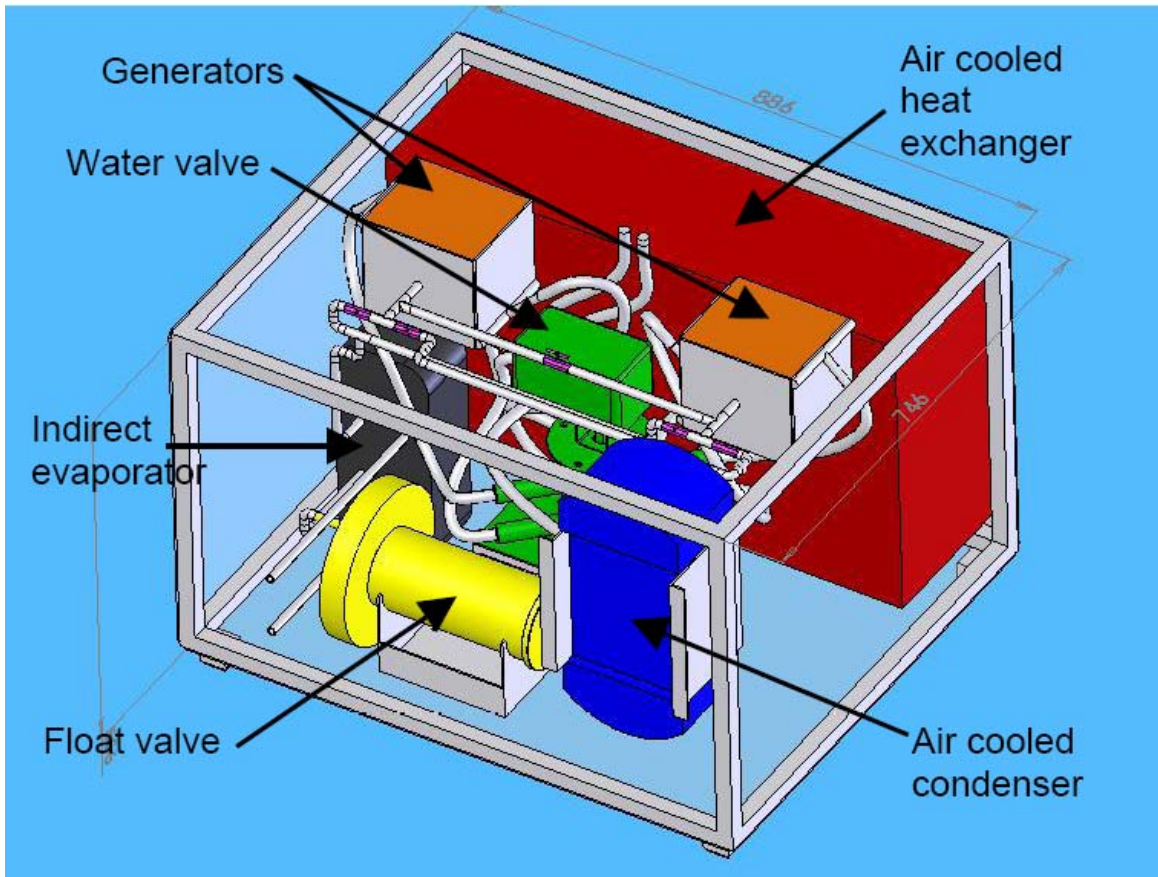
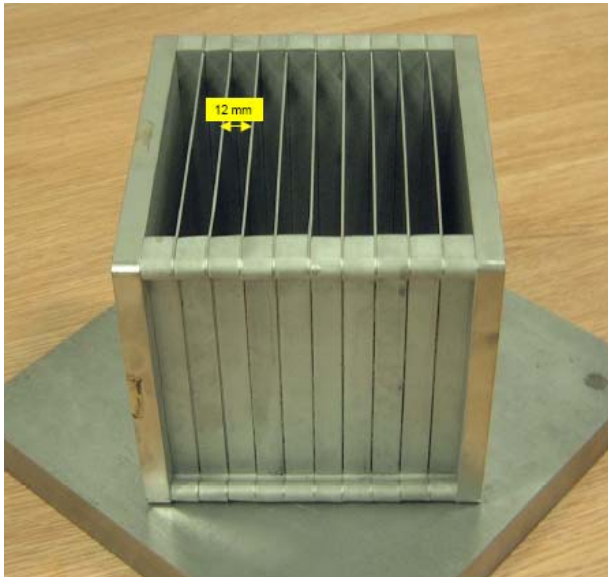

Figure 10: New MACS laboratory prototype – Version 2
Figure 10: Nouveau prototype de laboratoire de la MACS – Version 2



(a) View without water manifold



(b) View with water manifold

Figure 11: Photographs of the 2nd version of new generator under construction (12 mm slot)
Figure 11: Photographies de la 2^{de} version du nouveau générateur en construction (espace de 12 mm)



Figure 12: Prototype of 8-way valve operating with a $\frac{1}{4}$ turn fast electrical actuator (1 second)

Figure 12: Prototypé de la vanne à 8 portes opérant à $\frac{1}{4}$ de tour avec un rapide actuateur électrique (1 seconde)

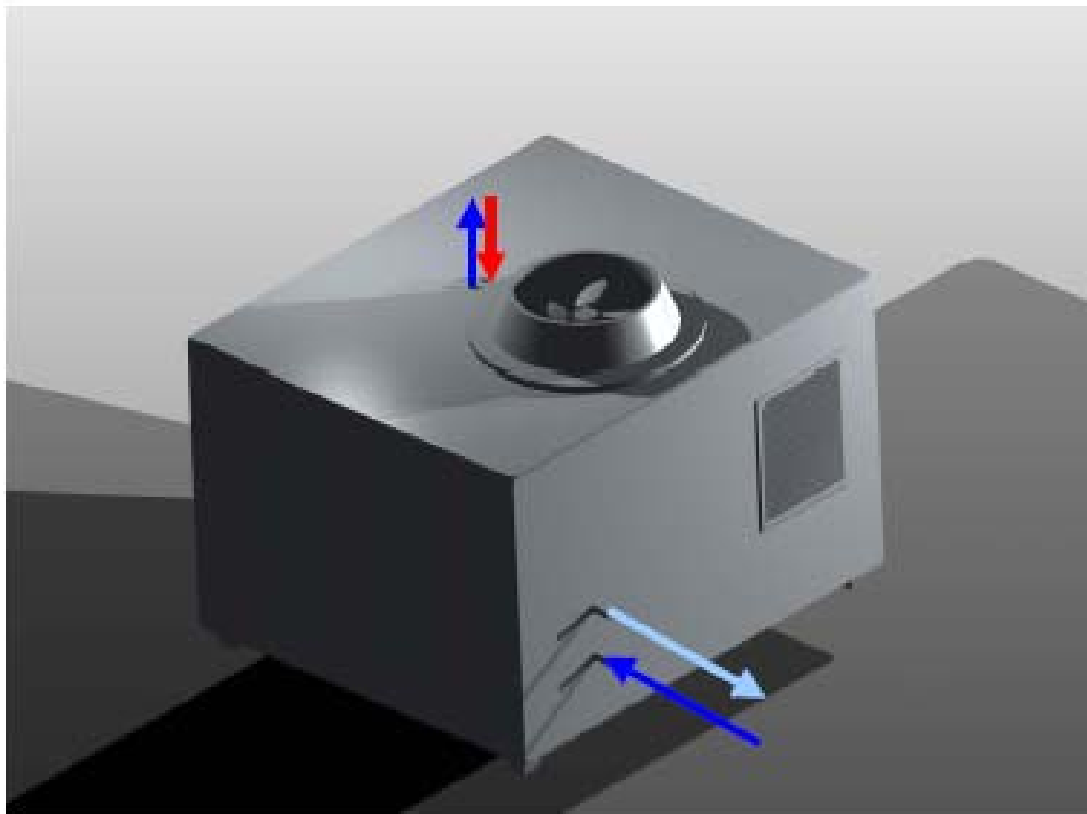

Fig 13: Simulated picture of the new Laboratory MACS Package – Version 2

Figure 13: Image simulée du nouveau prototype de laboratoire de la MACS – Version 2

Table 1: Novel generator specifications [4]**Tableau 1:** Specifications du nouveau generateur [4]

Type of carbon	Chemviron SRD1352/3 (compacted)
Filter	SS Mesh (grade 180)
Thermal enhancement additives	None
Sorbent density	435 kg m ⁻³
Mass of carbon	1 kg
Maximum concentration	0.37 kg NH ₃ kg ⁻¹ carbon
Total weight of reactor	9 kg
Operating temperature	200°C (maximum)
Operating pressure	20 bar (maximum)
Operating cycle time	60 seconds
UA value (water channels)	4150 W K ⁻¹
UA value carbon-NH ₃	420 W K ⁻¹
Bed thermal conductivity	0.42 W m ⁻¹ K ⁻¹
Overall bed UA value	380 W K ⁻¹

Table 2: Typical test of Normal European Summer Conditions and target performance**Tableau 2:** Norme Europeenne d'Essais en Eté et performances requises

<i>Normal European Summer Conditions</i>		
T _G – Generation inlet (°C)	80	90
T _A – Adsorption inlet (liquid) (°C)	32	
T _C – Condenser inlet (liquid) (°C)	32	
T _E –Evaporator inlet (liquid) (°C)	20	
Heat source flow rate (Maximum) (m ³ h ⁻¹)	1.44	
Heat sink flow rate (Maximum) (m ³ h ⁻¹)	1.44	
Flow rate – Condenser (liquid) (m ³ h ⁻¹)	0.30	
Flow rate–Evaporator (liquid) (m ³ h ⁻¹)	0.30	
<i>Target performance</i>		
Cooling power (kW)	1.2	
COP	0.52	0.24