

Technical University of Denmark



Determination of Fission Products in Irradiated Fuel by X-Ray Fluorescence

Mogensen, Mogens Bjerg; Als-Nielsen, Jens Aage; Andersen, Niels Hessel

Publication date:
1986

Document Version
Publisher's PDF, also known as Version of record

[Link back to DTU Orbit](#)

Citation (APA):
Mogensen, M. B., Als-Nielsen, J. A., & Andersen, N. H. (1986). Determination of Fission Products in Irradiated Fuel by X-Ray Fluorescence. Roskilde: Risø National Laboratory. (Risø-M; No. 2599).

DTU Library

Technical Information Center of Denmark

General rights

Copyright and moral rights for the publications made accessible in the public portal are retained by the authors and/or other copyright owners and it is a condition of accessing publications that users recognise and abide by the legal requirements associated with these rights.

- Users may download and print one copy of any publication from the public portal for the purpose of private study or research.
- You may not further distribute the material or use it for any profit-making activity or commercial gain
- You may freely distribute the URL identifying the publication in the public portal

If you believe that this document breaches copyright please contact us providing details, and we will remove access to the work immediately and investigate your claim.

RISØ-M-2599

DETERMINATION OF FISSION PRODUCTS IN IRRADIATED FUEL BY X-RAY
FLUORESCENCE

Mogens Mogensen*, Jens Als-Nielsen** and Niels Hessel Andersen**

* Metallurgy Department, ** Physics Department

Abstract. X-ray fluorescence is a well established analytical tool for measuring elemental composition of fairly large ($\sim 5 \text{ cm}^2$) "cold" samples. A version of this technique has been developed for analysis of radial distribution of fission products Xe, Cs and Ba in irradiated UO_2 fuel samples. About 0.1 mm thin slices of fuel pellets (full cross sections) are irradiated by 50 keV X-rays. The intensity of the Xe (Cs, Ba) $K\alpha$ fluorescence radiation generated is measured by means of a Ge detector fitted with a collimator. The slit is 0.5 mm wide in the scanning direction and 2 mm long. The measured Xe $K\alpha$ X-ray intensities are converted to absolute concentrations by comparing to the intensity from a Xe gas standard. In the case of Cs and Ba solid standards may be used. The X-ray fluorescence analysis is compared to other techniques used to obtain radial fission product profiles. It is shown how a combination of X-ray fluorescence and electron probe micro analysis is able to reveal the amount of Xe in the grain boundary porosities.

August 1986

Risø National Laboratory, DK-4000 Roskilde, Denmark.

**Paper presented at the EEC Hot Laboratories Meeting in Brasi-
mone, Italy, 21-23 May 1986.**

ISBN 87-550-1261-2

ISSN 0106-2840

Grafisk Service, Risø 1986

CONTENTS	Page
1. INTRODUCTION	4
2. EXPERIMENTAL	4
2.1 Sample Preparation	5
2.2 Experimental Set-up	5
3. RESULTS AND DISCUSSION	7
ACKNOWLEDGEMENT	8
REFERENCES	8
Table	9
Figures	10-20
DOCUMENT DATA PAGE	21

1. INTRODUCTION

Fission product release is probably the most important factor influencing the performance of water reactor fuel during a power transient. The mechanisms by which the volatile fission products are set free are still a matter for discussion, although fission product release from nuclear fuel has been studied for more than 20 years. Of the volatile fission products the fission gases Kr and especially Xe have drawn most attention. Consequently this paper is focussed on the fission gas Xe.

Post irradiation examinations (PIE) provide data on both integral and local levels of release. Volumetric analysis of the gas collected in the plenum is still the main source of integral release data. Local data have until now been provided by micro-coring (Refs. 1, 2), electron probe micro analysis (EPMA) (Refs. 3, 4) and laser sampling (Ref. 5). The limitations and advantages of these techniques are compared in Table 1 which also includes the new X-ray fluorescence (XRF) technique. The paper gives a description of the XRF method employed and some examples of Xe, Cs and Ba radial concentration profiles. The Xe profiles obtained are compared to Xe profiles measured by EPMA on adjacent fuel samples.

2. EXPERIMENTAL

A rotating anode high intensity X-ray generator (Trademark: RI-GACU) is used as the X-ray source. In order to obtain as high an X-ray intensity on the sample surface as possible the sample should be placed as close to the X-ray source as possible. This prevented a construction of a massive lead shield for irradiation protection, and consequently it is necessary to minimize the sample size.

2.1. Sample Preparation

A sample sufficiently long to contain a full pellet is cut from the fuel pin. This sample is impregnated with araldite and cut longitudinally close to the pellet center. Afterwards the half pellet is imbedded in perspex together with a thin metal ring as shown in Fig. 1. The sample surface is ground on 600 grit paper. Next, the perspex and the sample is cut in the plane A-A (see Fig. 1). Then the sample is further ground from the "A-A" side after a remounting. Because it is impossible to cut the A-A-plane exactly parallel to the surface (Fig. 1) the ring will be grounded away in a single spot before all the sample is removed. Thus, when the ring has disappeared at one location an approximately 0.1 mm thick fuel sample containing a full longitudinal pellet cross section is prepared. For such a sample of fuel with a burnup of 4% FIMA (fissions of initial metal atoms) and a cooling time of one year the radiation level is less than 5 R/h in 10 cm distance and below 50 mR/h when shielded with a 5 cm lead.

2.2. Experimental Set-up

Fig. 2 shows a horizontal section through the spectrometer developed by the Physics Department at Risø. The fuel sample is placed in a lead shielded container (7 cm lead). The sample is irradiated with an X-ray beam which is 4 mm wide and sufficiently long to cover the full width of the sample. The X-ray beam hits the sample surface at an angle of 45° .

The intensity of the characteristic fluorescent $K\alpha$ X-ray radiation is measured by a germanium solid state detector. In order to avoid a saturation of the detector because of the β and γ radiation from the sample, the $K\alpha$ lines of Xe, Cs and Ba are deflected by a graphite crystal. Then only a narrow range of radiation energies around the wanted $K\alpha$ lines reaches the detector. Around 30 keV (Xe, $K\alpha = 29.8$ keV) the energy interval which can be measured through the graphite crystal is about 5 keV. The deflected angle (the Bragg angle) is 3.5° .

The fluorescent radiation intensity measurement is by a collimator confined to a small area of the sample. The collimator slit is 0.5 mm wide in the scanning direction and 2 mm long. The collimator line is perpendicular to the incoming excitation radiation beam. This gives the lowest Compton background. Thus the collimator line makes a 45° angle to the sample surface, and an area of 0.5 mm x 2 mm of the surface is seen through the collimator. By scanning with step lengths of 0.25 mm a radial resolution of about 0.5 mm is obtained.

Fig. 3 shows a vertical section in the plane of the sample surface through the experimental set-up, and through the container used for the transportation of samples from the hot cells in the Metallurgy Department to the Physics Department. The location of the sample relative to the incoming and leaving radiation beams is controlled by means of two translation devices.

The position of the sample relative to the collimator line is determined by measuring the intensity of the U-L α line at 13.55 keV during a scan. The result of a horizontal scan is shown in Fig. 4. Such a scan also reveals the presence of possible cracks and loss of fuel, and makes it possible to correct the measured concentration for cases where the collimated area is only partly filled with fuel.

As calibration a standard material (gaseous, liquid or solid) with known elemental concentration and X-ray absorption coefficient may be used in order to convert count rates into concentrations. For Xe gaseous standards are used.

The data acquisition is carried out by means of a CANBERRA multichannel analyzer and a PDP11 computer.

3. RESULTS AND DISCUSSION

Fig. 5 gives a spectrum obtained from a sample irradiated to a burnup of 3.4% FIMA together with the background spectrum measured on unirradiated UO_2 . The areas of the peaks above the background is taken as representing the Xe, Cs and Ba concentrations, respectively.

Fig. 6 shows a plot of Xe concentrations as measured by XRF versus the Xe concentration calculated from burnup and fission yields. All the measurements were made at a radial position of the samples of about 0.8 where the concentration is close to the average Xe generation in the sample, and where the fuel has been cold enough to retain all Xe generated. Taking into account the uncertainties on the fission yields and on the burnup a relative uncertainty of 10% (one standard deviation) is estimated from Fig. 6. Often the uncertainty on the relative radial distribution of Xe is more important than on the absolute concentrations. In such a case where calibration is not necessary, the uncertainty on the determination of the relative Xe concentration is estimated to be 5% of the Xe concentration in the cold fuel close to the rim. This is valid for fuel in the burnup range of 3-5% FIMA.

Figs. 7 and 8 show examples of radial Cs and Ba profiles for the same sample. It is seen that the central part is depleted in Cs (Fig. 7) but almost all Ba is retained (Fig. 8). In both cases a full diameter was measured. Good symmetry was observed and therefore both radii were plotted together. The larger scatter on the barium results is due to the lower absolute concentration of Ba as compared to Cs, and because the detector was focused on Xe giving a lower counting efficiency on the Ba line.

Figs. 9 and 10 show radial Xe distribution as measured by XRF together with the Xe profiles measured by EPMA on adjacent fuel samples. The point here is that all Xe including the gas in grain boundary porosities is measured by XRF whereas EPMA only measures the Xe in the fuel matrix and in bubbles smaller than

0.1 μm inside the grains. Thus the difference between the two curves gives the amount of Xe situated in the grain boundary porosities. In both cases of Figs. 9 and 10 the fuel was submitted to a power transient in the range of 300-400 W/cm for about 24 h.

The release of Xe from a full cross section can be determined by integratic of the radial distribution curve. In 4 cases samples from fuel pins without significant axial power variation have been measured by XRF. In such cases the integral Xe release determined by XRF may be compared directly to the integral release measured by puncture. The two sets of data for the four samples are shown in Fig. 11. A reasonable agreement is observed.

ACKNOWLEDGEMENTS

The authors would like to thank C. T. Walker, Institute of Transuranium Elements for providing the EPMA data shown in Figs. 9 and 10.

REFERENCES

1. W. W. Morgan et al., " A Preliminary Report on Radial Distribution of Fission Product Xe and Cs in UO_2 Fuel Elements", Report AECL-1249, 1961.
2. D. D. Lanning and E. R. Bradley, "Irradiation History and Interim Post-Irradiation Data for IFA432", Report NUREG/CR-3071, 1984.
3. C. T. Walker, J. Nucl. Mater. 80 (1979) 190.
4. C. Ronchi and C. T. Walker, J. Phys. D: Appl. Phys., 13 (1980) 2175.
5. D. G. Graczyk et al., " A Laser Microsampling Method for Determination of Retained Fission Gas in Irradiated Nuclear Fuels", Report ANL-79-86 (1979).

Table 1. Overview of Methods for the Local Measurement of Retained Fission Gas.

Method	Advantages	Disadvantages
Micro-coring	<p>(a) Measures total gas (Xe+Kr) with dissolution</p> <p>(b) Possibility of measuring "pore gas" with crushing.</p>	<p>(a) Coarse radial resolution, $\sim 1^+$ mm.</p> <p>(b) The least abundant isotope Kr-85 is sometimes the one analysed.</p> <p>(c) Uncertainty as to which extent the "pore gas" is grain boundary gas.</p>
EPMA	<p>(a) Very fine radial resolution, $\sim 2.5 \mu\text{m}$.</p>	<p>(a) Very small depth of analysis, $\sim 0.5 \mu\text{m}$</p> <p>(b) Only Xe in matrix and in bubbles smaller than $0.1 \mu\text{m}$ is analysed</p>
Laser sampling	<p>(a) Fine radial resolution $\sim 10 \mu\text{m}$</p>	<p>(a) Only Kr-85 is measured.</p> <p>(b) Difficult to quantify the amount of fuel from which the gas comes.</p>
XRF	<p>(a) Depth of analysis $\sim 30 \mu\text{m}$, using the Xe-Kα line.</p> <p>(b) Measures total Xe.</p> <p>(c) Radial resolution $\sim 0.5 \text{ mm}$</p>	<p>(a) Only Xe is measured</p>

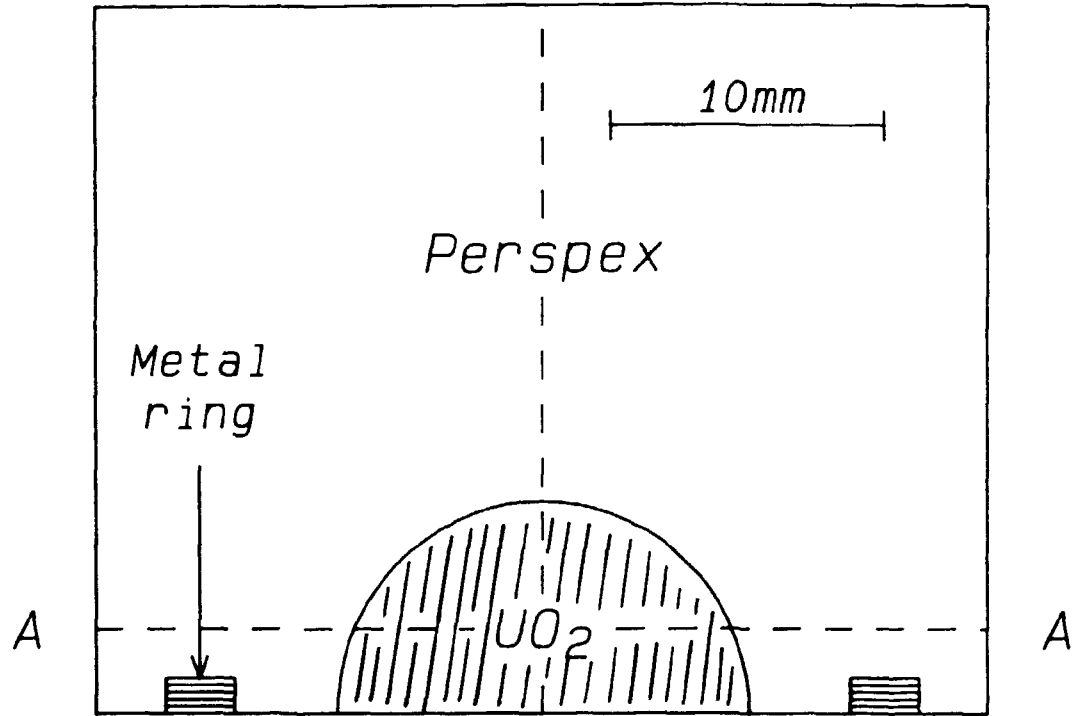

Fig. 1. Sketch of the sample preparation principle. After grinding of the surface a cut is made in plane A-A. After remounting the grinding (from plane A-A side) is continued until the metal ring is removed in just one location. This procedure gives a sample thickness of about 0.1 mm.

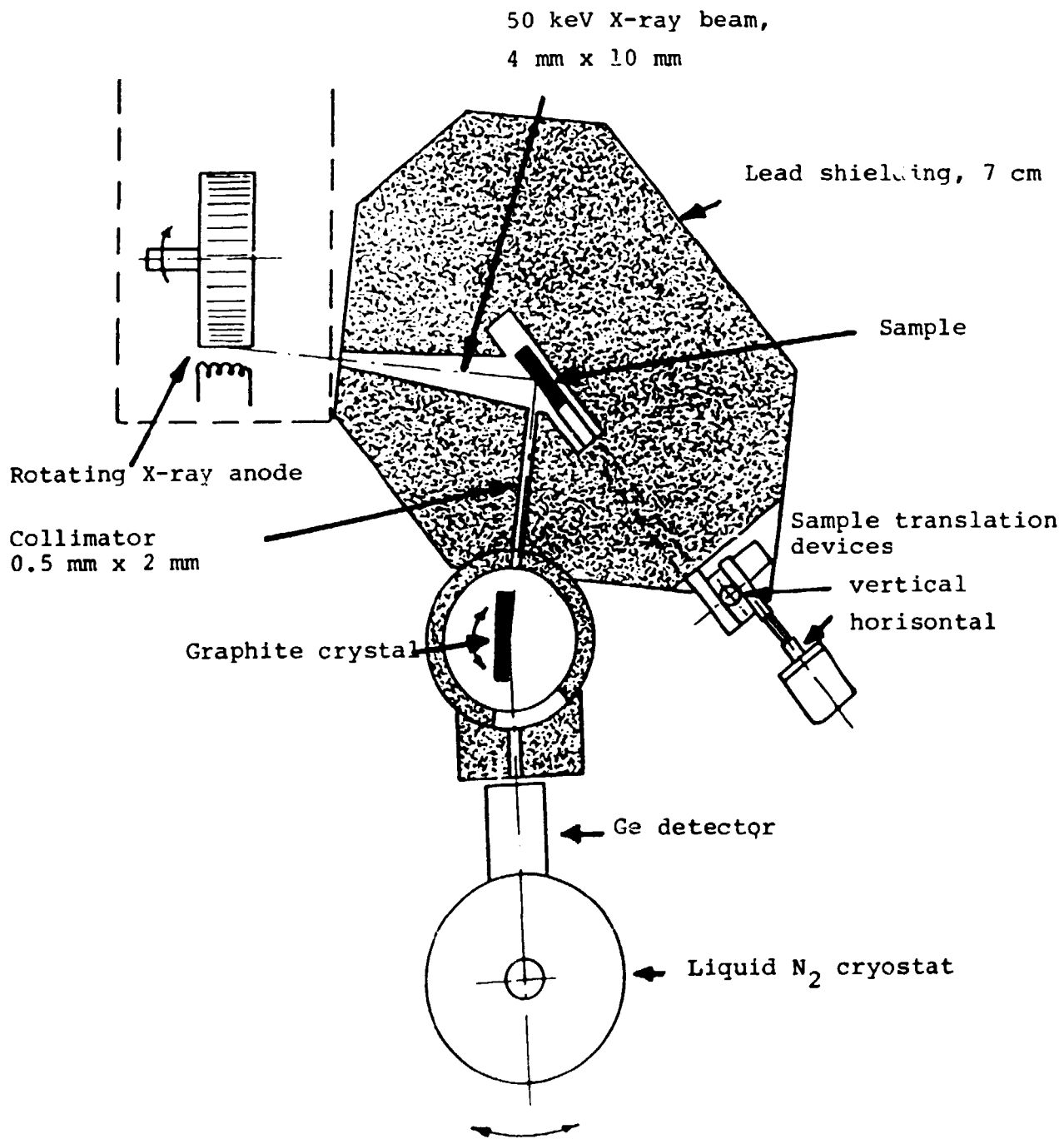

Fig. 2. Horizontal section through the experimental set-up.

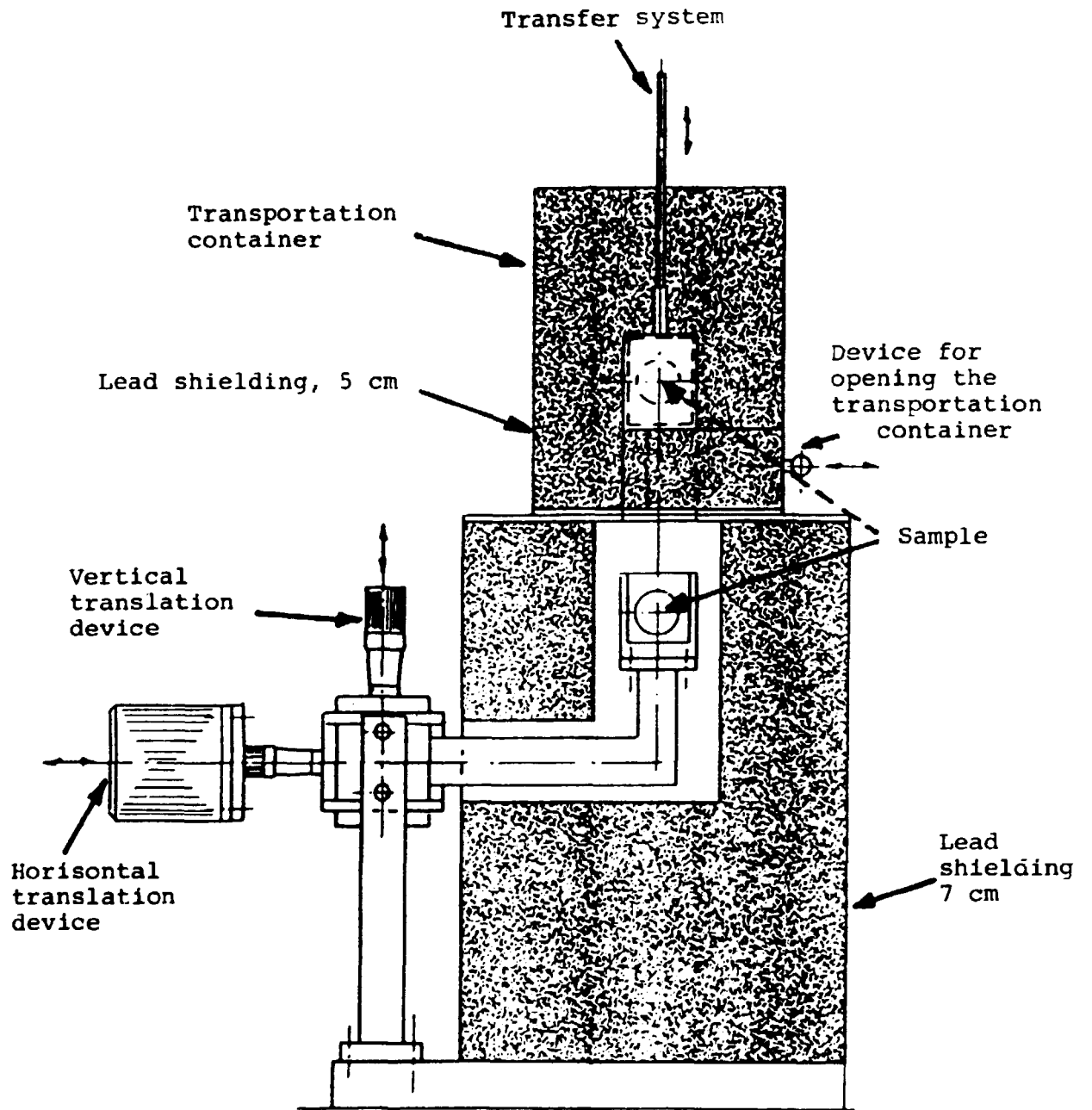

Fig. 3. Vertical section through the experimental set-up.

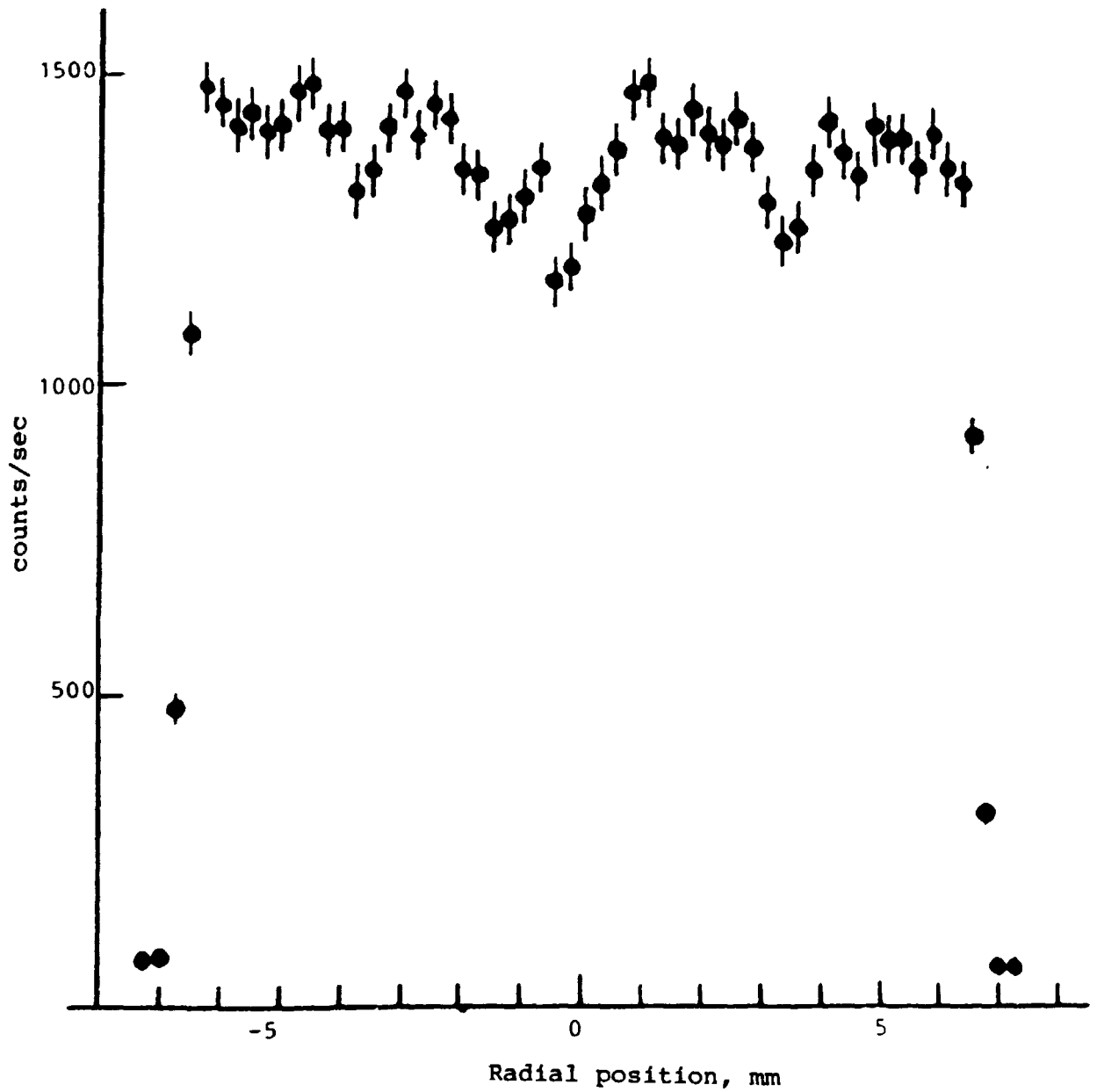

Fig. 4. Radial variation of the U-La fluorescence (13.55 keV) from a fuel sample. This scan is used for the determination of the sample edge position in the X-Y stage and for determination of the extent of cracks in the fuel.

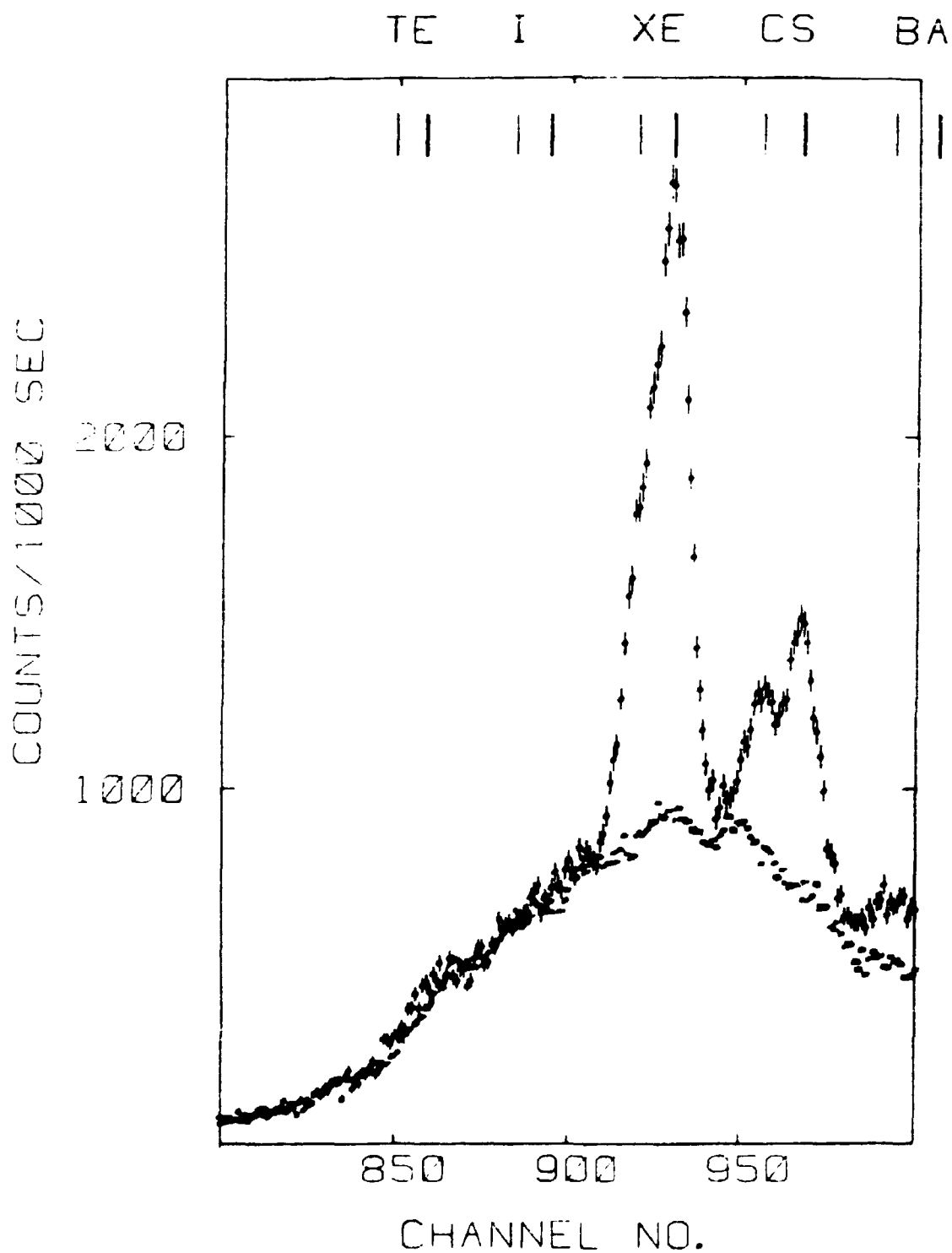

Fig. 5. Spectrum and background spectrum measured on UO_2 fuel with a burnup of 3.4% FIMA. The background spectrum is measured on an unirradiated fuel sample. The $K\alpha_1$ (thick) and $K\alpha_2$ (thin) line positions are indicated at the top of the Figure for the elements Te to Ba. Only Xe, Cs and Ba is detected.

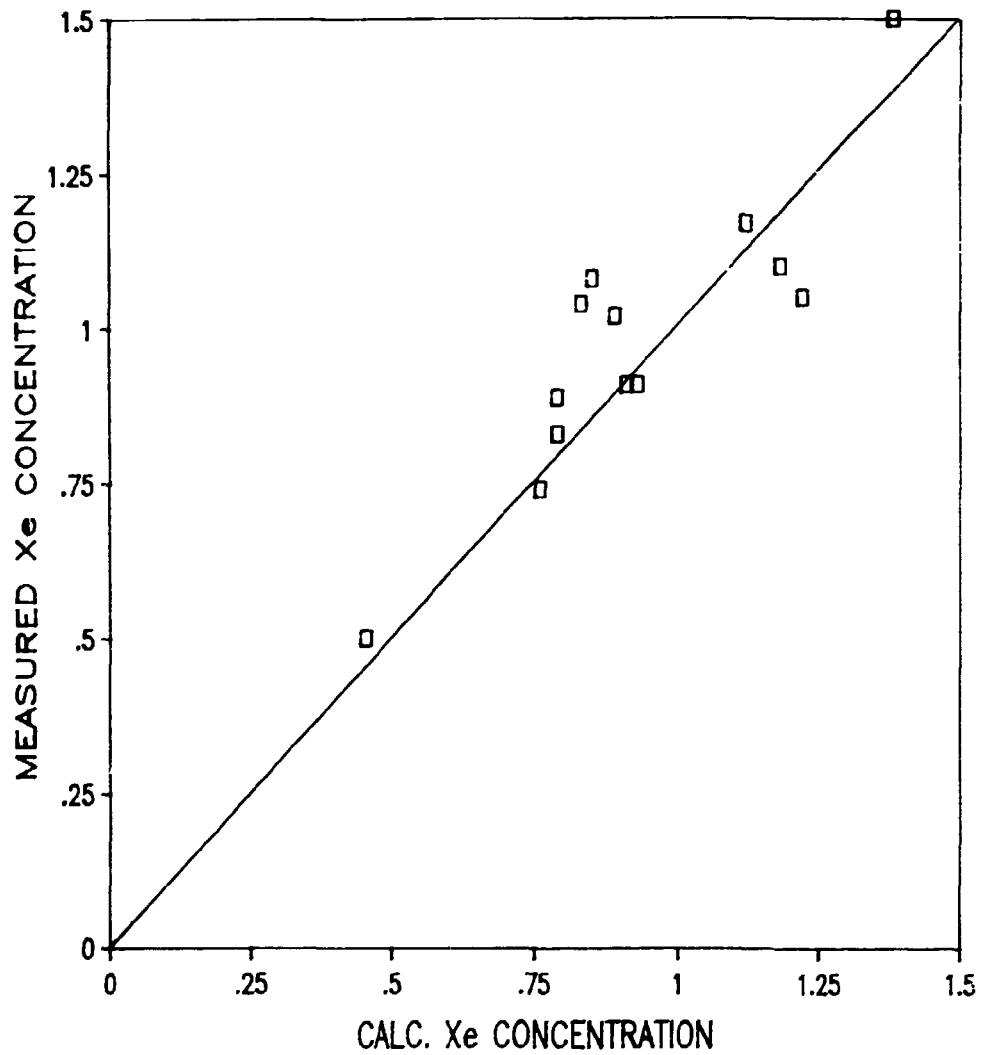

Fig. 6. Plot of measured (by XRF) vs. calculated Xe concentrations (in % of initial metal atoms). The calculated concentrations are found from measured burnups and literature values of fission yields.

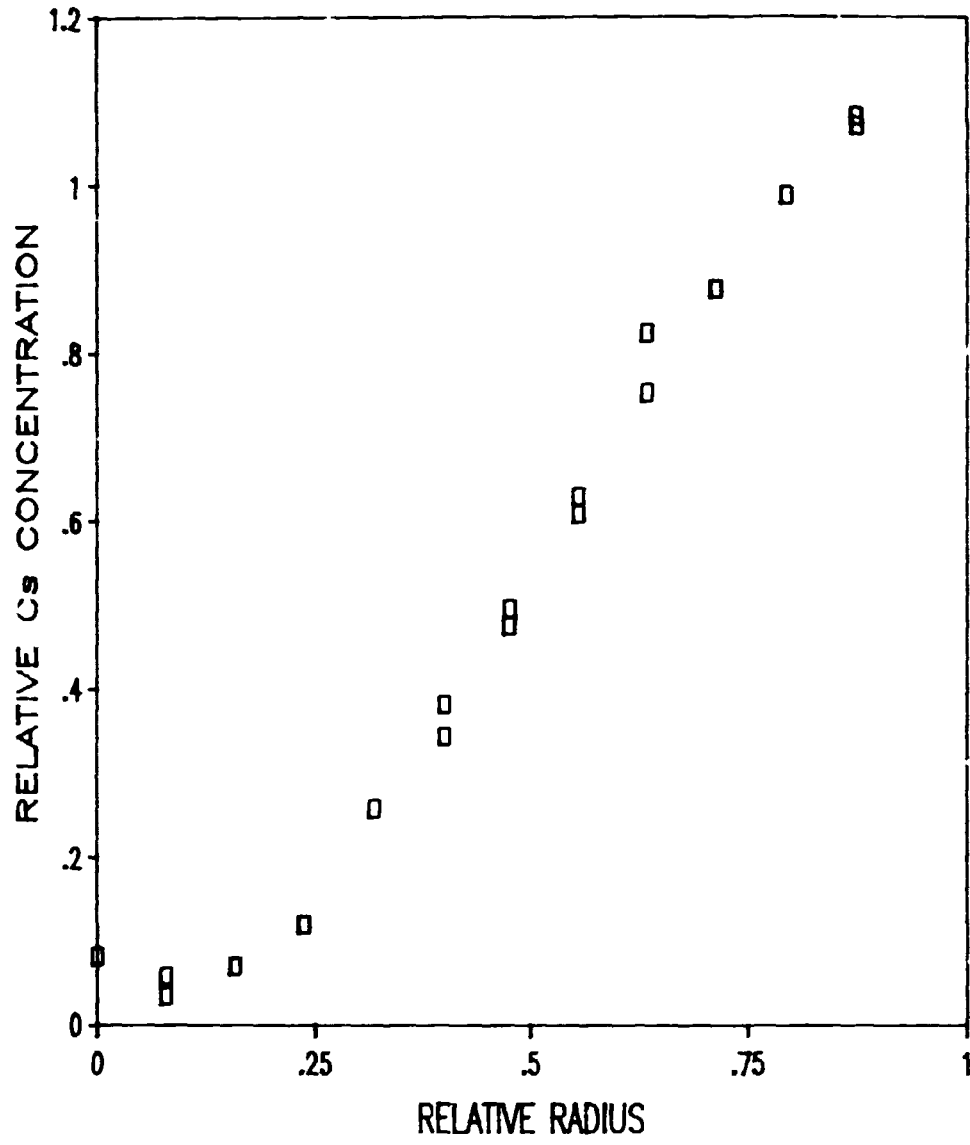

Fig. 7. Cs concentration profile.

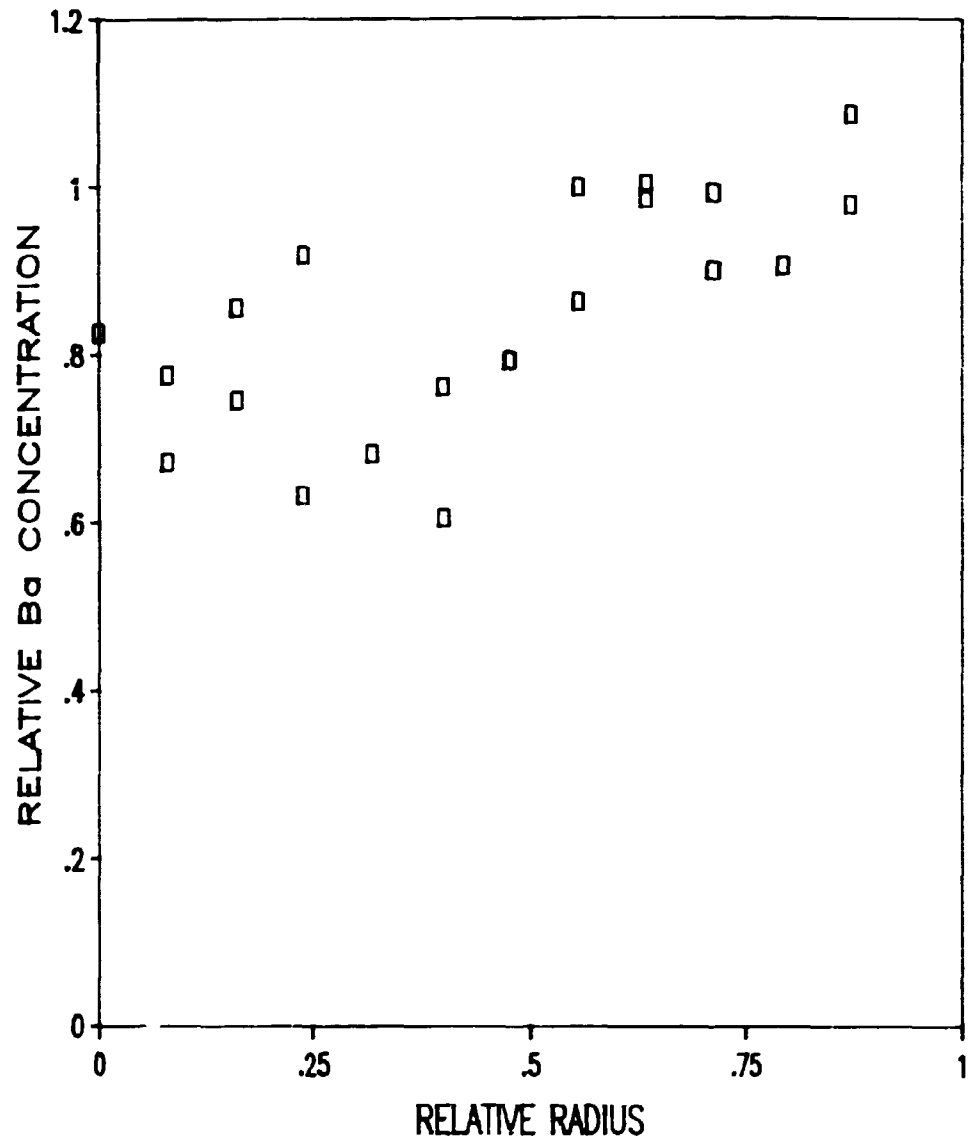

Fig. 8. Ba concentration profile.

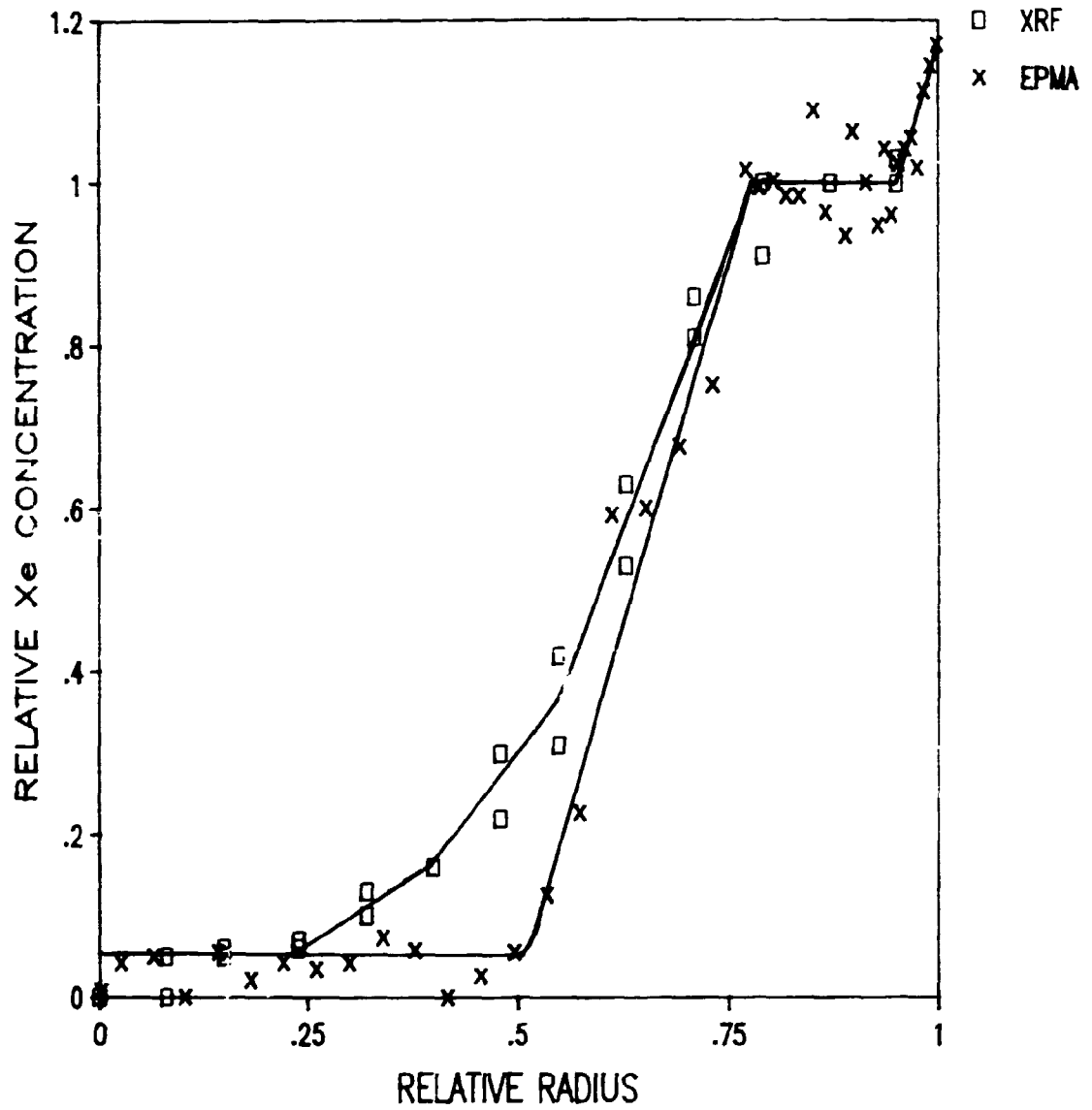

Fig. 9. Radial concentration profiles of Xe measured by XRF (total Xe) and by EPMA (Xe inside grains). The difference gives the gas in the grain boundary porosities. The fuel was bump tested at 42 kW/m for 24 h. Burnup 4.3% PIMA.

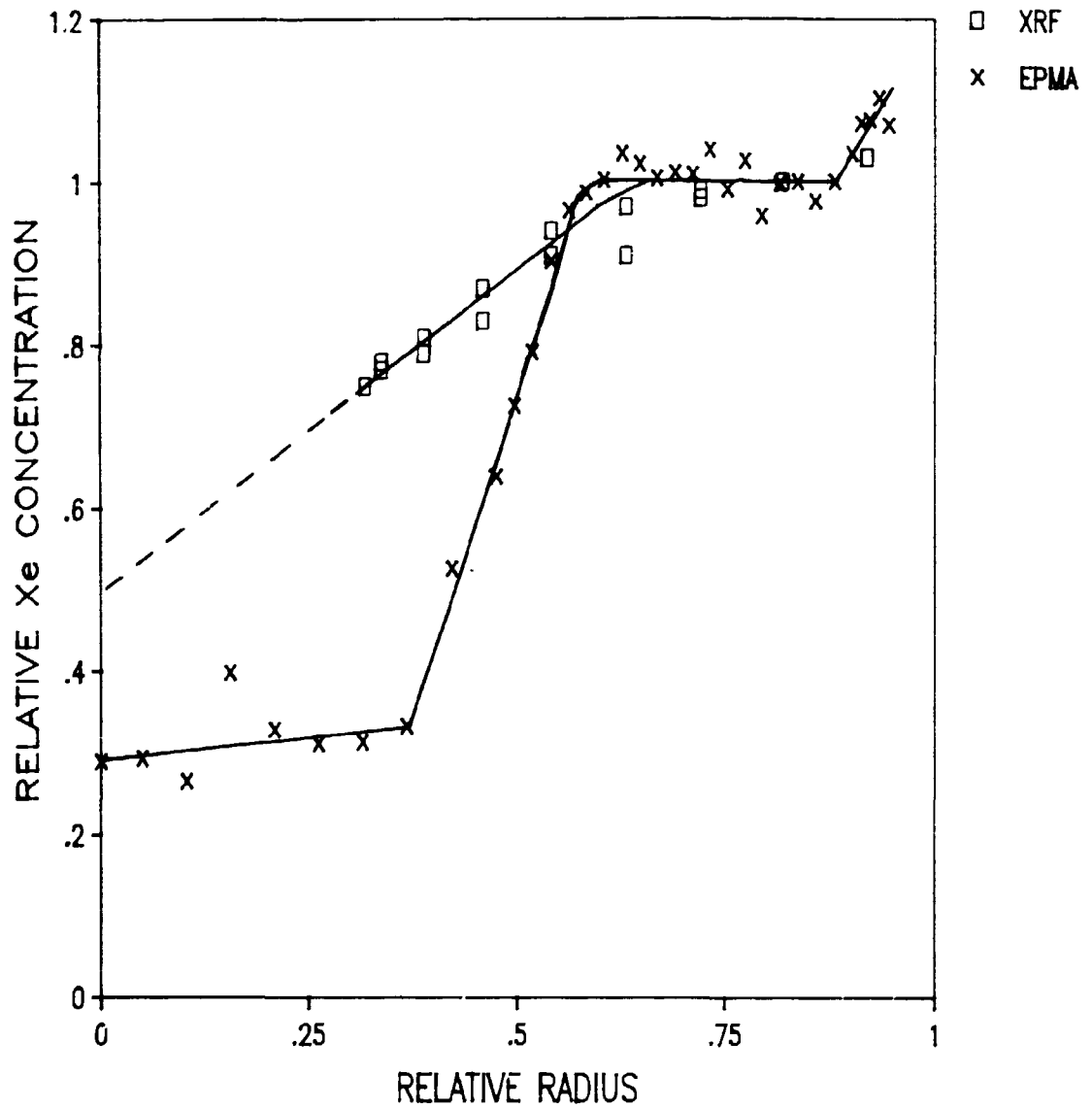

Fig.10. Radial concentration profiles of Xe measured by XRF (total Xe) and by EPMA (Xe inside grains). The difference gives the gas in the grain boundary porosities. Unfortunately the central part of the fuel in the XRF sample was lost during preparation. The fuel was bump tested at 32 kW/m for 28 h. Burnup 3.4% FIMA.

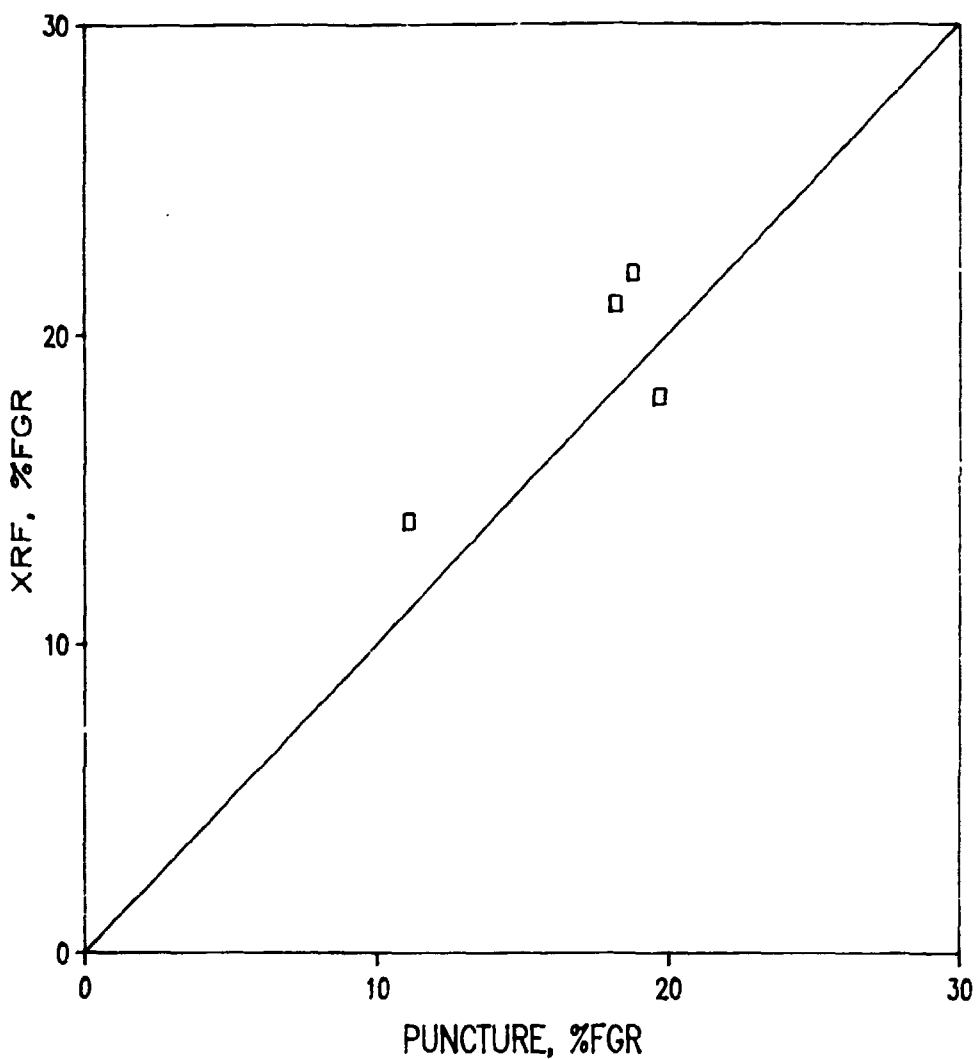

Fig. 11. Comparison of intergral release results obtained by integration of XRF measured Xe radial profiles and puncture results.

<p>Title and author(s)</p> <p>Determination of Fission Products in Irradiated Fuel by X-ray Fluorescence</p> <p>Mogens Mogensen, Jens Als-Nielsen, Niels Hessel Andersen</p>	<p>Date August 1986</p> <p>Department or group Metallurgy Department Physics Department</p> <p>Groups own registration number(s)</p> <p>Project/contract no.</p>
<p>Pages 21 Tables 1 Illustrations 11 References 5</p>	<p>ISBN 87-550-1261-2</p>
<p>Abstract (Max. 2000 char.)</p> <p>X-ray fluorescence is a well established analytical tool for measuring elemental composition of fairly large ($\sim 5 \text{ cm}^2$) "cold" samples. A version of this technique has been developed for analysis of radial distribution of fission products Xe, Cs and Ba in irradiated UO_2 fuel samples. About 0.1 mm thin slices of fuel pellets (full cross sections) are irradiated by 50 keV X-rays. The intensity of the Xe (Cs, Ba) $K\alpha$ fluorescence radiation generated is measured by means of a Ge detector fitted with a collimator. The slit is 0.5 mm wide in the scanning direction and 2 mm long. The measured Xe $K\alpha$ X-ray intensities are converted to absolute concentrations by comparing to the intensity from a Xe gas standard. In the case of Cs and Ba solid standards may be used. The X-ray fluorescence analysis is compared to other techniques used to obtain radial fission product profiles. It is shown how a combination of X-ray fluorescence and electron probe micro analysis is able to reveal the amount of Xe in the grain boundary porosities.</p>	
<p>Descriptors - INIS:</p> <p>BARIUM; CESIUM; COMPARATIVE EVALUATIONS; ELECTRON MICROPROBE ANALYSIS; FISSION PRODUCT RELEASE; MULTI-ELEMENT ANALYSIS; SPENT FUELS; X-RAY FLUORESCENCE ANALYSIS; XENON</p> <p>Available on request from Risø Library, Risø National Laboratory, (Risø Bibliotek, Forsøgsanlæg Risø), P.O. Box 49, DK-4000 Roskilde, Denmark. Telephone (02) 37 12 12, ext. 2267. Telex: 43115, Telefax: (02) 36 00 09</p>	