

Technical University of Denmark



Integrated Approach to Computer Aided Process Synthesis

Hostrup, Martin; Gani, Rafiqul

Publication date:
2002

Document Version
Publisher's PDF, also known as Version of record

[Link back to DTU Orbit](#)

Citation (APA):
Hostrup, M., & Gani, R. (2002). Integrated Approach to Computer Aided Process Synthesis.

DTU Library

Technical Information Center of Denmark

General rights

Copyright and moral rights for the publications made accessible in the public portal are retained by the authors and/or other copyright owners and it is a condition of accessing publications that users recognise and abide by the legal requirements associated with these rights.

- Users may download and print one copy of any publication from the public portal for the purpose of private study or research.
- You may not further distribute the material or use it for any profit-making activity or commercial gain
- You may freely distribute the URL identifying the publication in the public portal

If you believe that this document breaches copyright please contact us providing details, and we will remove access to the work immediately and investigate your claim.

Integrated Approach to Computer Aided Process Synthesis

Ph.D. Thesis

Martin Hostrup
CAPEC

Department of Chemical Engineering
Technical University of Denmark

December 2001

Preface

This thesis is submitted as partial fulfillment of the requirements for the Ph.D.-degree at Danmarks Tekniske Universitet (Technical University of Denmark). The work has been carried out at Institut for Kemiteknik (Department of Chemical Engineering) from October 1997 to December 2001 under the supervision of Professor Rafiqul Gani. I am grateful for the funding for this work, which has been partially financed by the Nordic Energy Research Programme (Petroleums teknologi programmet) and by the Global CAPE Open (GCO) project, which was funded by the European Commission (Contract No.: BRPR-CT96-0293).

I would like to thank all the students and coworkers at the Computer Aided Process Engineering Center (CAPEC) at the Department of Chemical Engineering, Technical University of Denmark for making the center a fun and inspiring place to work and do research. I am grateful to Peter Harper for the long time collaboration which is continuously bringing new inspiration to the development of tools and solution approaches. Special thanks should go to him and other current and former coworkers at CAPEC with whom I have had particularly close and good collaboration.

Special thanks go to Dr. Rafiqul Gani for good collaboration and inspiration, but especially for giving me extraordinary opportunities that not only has helped my research for this thesis but which I'm sure will also help in my future professional life.

Finally I would like to thank my family and friends for their support and understanding even if finishing the thesis was a long process. I would like to thank my wife, Astrid, for her help but especially for being there the many times when moral support was needed.

Ishøj, December 2001

Martin Hostrup

Abstract

This thesis describes the development of an integrated framework for process synthesis of chemical and pharmaceutical processes. The developed framework addresses the problem of generation and solution of flowsheets and superstructures in order to determine the optimal configuration. This is achieved by dividing the task into 3 phases: pre-analysis, flowsheet/superstructure generation and flowsheet/superstructure simulation and optimization. In the pre-design phase the problem is identified and an initial problem formulation is made. Also knowledge bases as well as tools are consulted to gather the information needed for the flowsheet generation phase. In the flowsheet generation phase the process is divided into reaction and separation blocks. The individual blocks are processed one by one, thereby generating superstructure fragments. After processing of all blocks the fragments are combined. Also in the flowsheet generation phase, a new algorithm for design of distillation columns is used in order to determine the column specifications. Furthermore, this algorithm also generates initialization values for later use in simulation and optimization. In the simulation and optimization phase the feasibility of the initial flowsheet is validated and an optimization problem for determination of the optimal flowsheet configuration is solved. In the case where alternatives exist (in the form a superstructure), a structural optimization technique based on an interactive MINLP solver, is employed. The developed framework and associated methods have been tested using a series of case studies and application examples.

Resumé på dansk

Mange aktiviteter indenfor procesudviklings området bliver kaldt 'Proces Syntese'. I denne afhandling referer proces syntese til generering af præliminært proces design, primært for kemiske og farmaceutiske processer. Præliminært proces design udføres når der opstår et ønske fra firmaledelsen om at undersøge hvorvidt en investering skal foretages eller ikke, det være sig tilpasning af en eksisterende proces eller opbygning af en helt ny proces.

Den computer baserede integrerede metodik for proces syntese, som er præsenteret i denne afhandling, kan lette proces ingeniørens job i udarbejdelsen af præliminært proces design. Den opgave som proces ingeniøren udfører i forbindelse hermed, kan karakteriseres som kvalificeret udvælgelse blandt de mange mulige designs, der kan overvejes for processen. Ideen er ikke at dette nu kan udføres fuldautomatisk ved brug af den integrerede metodik. Den integrerede metodik skal i stedet, ved bruger interaktion, hjælpe med generere beskrivelser af muligheder og screene blandt disse, således at den bedste løsning 'overlever' til den endelige evaluering.

Den integrerede metodik adresserer ovenstående problem ved at opdele det i tre faser: pre-analyse, flowsheet/superstruktur generering og flowsheet/superstruktur simulering og optimering. I pre-analyse fasen bliver problemet identificeret og en første problem formulering bliver lavet. Derudover bliver vidensbaser og computer baserede værktøjer brugt til at samle den information der er påkrævet i næste fase. I flowsheet genererings fasen bliver processen først delt op i reaktions og separations blokke. For hver blok bliver der så genereret (superstruktur) fragmenter. Efter behandling af alle blokke bliver fragmenterne samlet til et stort flowsheet eller en superstruktur. En nyudviklet algoritme til design af destillationskolonner kan herefter anvendes. Resultater fra denne algoritme er design parametre og initialiseringsværdier, der kan anvendes ved simulering af destillationskolonner i flowsheetet. I simulering og optimerings fasen bliver det først valideret at genererede flowsheet opfylder målet med processen. Derefter kan et optimeringsproblem til bestemmelse af den optimale flowsheet konfiguration løses. I det tilfælde hvor der eksisterer alternativer for nogle af flowsheetets komponenter kan en strukturel optimeringsteknik, kaldet 'den interaktive MINLP solver', anvendes. Brugen af den integrerede metodik og de tilhørende algoritmer er belyst ved en række eksempler.

Contents

Preface	iii
Abstract	v
Resumé på dansk	vii
1 INTRODUCTION	1
2 THEORETICAL BACKGROUND	3
2.1 Introduction	3
2.2 Flowsheets	4
2.2.1 Representation of superstructures	5
2.3 Process synthesis	6
2.3.1 Synthesis of reactors and reactor networks	7
2.3.2 Separation system synthesis	8
2.3.3 Synthesis of Heat Exchanger Networks and Process Integration	10
2.3.4 Flowsheet synthesis	12
2.3.5 Integrated approach	13
2.4 Tools and resources for Process Synthesis	14
2.4.1 Compound properties	14
2.4.2 Simulation and optimization	17
2.4.3 Integrated environment	19
3 ALGORITHMS AND TOOLS	21
3.1 Introduction	21
3.2 Problem formulation	21
3.2.1 Design problems including selection of solvents	25
3.3 Algorithms and tools for process synthesis	27
3.3.1 Reaction analysis tool	27
3.3.2 Separation synthesis	32
3.3.3 Process design tool (separation processes)	33
3.3.4 Other methods/tools in the integrated framework	40
3.3.5 Structural optimization tool	41
4 INTEGRATED PROCESS SYNTHESIS FRAMEWORK	45
4.1 Introduction	45
4.2 Pre-analysis	46
4.2.1 Problem type and formulation	46
4.2.2 Collection of property knowledge	48

4.2.3	Reaction knowledge	50
4.2.4	Information on external media based separations	50
4.3	Flowsheet and superstructure generation	51
4.3.1	Algorithm for generation of initial flowsheets and superstructure	51
4.3.2	Solvent based separation	60
4.4	Simulation and optimization	65
5	APPLICATION EXAMPLES	69
5.1	Introduction	69
5.2	Reaction kinetics estimation	69
5.2.1	Ethylene glycol	70
5.2.2	Multiple reactions	73
5.3	Distillation design	74
5.3.1	Separations in methyl-acetate production	74
5.4	Hybrid approach to process synthesis	78
5.4.1	Production of Cyclohexane	78
5.4.2	Generation of superstructure	80
5.4.3	Structural optimization	84
5.4.4	Separation of acetone from chloroform	88
5.5	Methanol synthesis	97
5.5.1	Pre-analysis phase	99
5.5.2	Flowsheet generation phase	102
5.5.3	Simulation and optimization	103
6	CONCLUSIONS	105
6.1	Achievements	105
6.2	Future work	107
6.2.1	Structural optimization	107
6.2.2	Process design	107

Appendices

A	Property - separation techniques relationship	111
B	Methodology for synthesis and design of separation processes	115
C	Application of reaction analysis studio	117
D	Reaction data – for example in section 5.2.2	123
E	Additional results from Distillation design	127
F	Input file example for a MILP master problem	129

G Result file for the acetone - chloroform CAMD problem	133
H Stream summary for the methanol production	141
List of definitions	145
Nomenclature	149
References	151

List of Figures

2.1	Unit symbols	4
2.2	Two different representations of a connection	5
2.3	Use of logical splitters	6
2.4	Flowsheet synthesis problem	13
3.1	Activity diagram for the synthesis of a preliminary design	24
3.2	Reaction analysis tool – overview	27
3.3	Reaction database structure	29
3.4	Triangular diagram of liquid compositions for n-Butane, n-Pentane and n-Octane	38
3.5	Equilibrium based algorithm	38
3.6	Equilibrium based algorithm, cont.	39
3.7	Role of ICAS in the integrated framework for process synthesis	40
3.8	Information flow in the interactive MINLP algorithm	41
4.1	The main components in the phases	47
4.2	Generic superstructure for removal of liquid species from a liquid mixture	61
4.3	Flow diagram for the CAMD algorithm of Harper <i>et al.</i> (1999)	64
5.1	Parity plots	72
5.2	Tray vs composition plot	77
5.3	Original flowsheet	79
5.4	Txy diagram for cyclohexane/benzene	82
5.5	xy and Sep. Eff. diagrams for cyclohexane/benzene	82
5.6	Residue curve map for cyclohexane/benzene separation	83
5.7	The superstructure fragment for the separation block.	84
5.8	Complete superstructure	85
5.9	T-xy diagrams for the system acetone-chloroform at 0.5, 1.0, 5.0 and 40 Bar.	89
5.10	Reduced superstructure after step 4.D.	90
5.11	Solve summary solvent design problem.	93
5.12	VLE diagram (solvent free basis).	94
5.13	Residue curve maps for the selected solvents.	94
5.14	Reduced superstructure after step 4.D.	95
5.15	Parity plots for methanol kinetics	101
5.16	Flowsheet generated for methanol production	103
A.1	Property - separation techniques relationship	112

A.2 Property - separation techniques relationship, continued	113
--	-----

List of Tables

2.1	Number of possible sequences to separate NC components by NT potential separation techniques	10
4.1	List of pure component properties required for screening of feasible separation techniques	49
4.2	List of separation techniques suitable for the removal of a chemical species from a mixture	53
4.3	Separation superstructure alternative (complete enumeration) .	62
5.1	Ethylene glycol formation as function of time	70
5.2	Composition of reactor effluent	75
5.3	Column design details for the methanol/water split	76
5.4	Simulation results for the MeOH / Water split column.	78
5.5	Feedstocks available for cyclohexane production.	79
5.6	Specification values used	85
5.7	Values of cost constants.	86
5.8	Solution summary for cyclohexane production	87
5.9	Reduced separation superstructure	91
5.10	Optimization results using the interactive MINLP-algorithm . .	98
5.11	Synthesis gas for Methanol production	99
5.12	Exaperimental vs. calculated values.	101
5.13	Column design details for methanol production.	103
5.14	Costs used in the objective function	104
5.15	Optimal values for design values.	104

INTRODUCTION

Many activities in the area of process development are labeled 'Process Synthesis'. In the context of this thesis the term process synthesis refers to the generation of a preliminary design for primarily chemical and pharmaceutical manufacturing processes. The preliminary design task is carried out whenever corporate management wants to investigate if an investment should be made, either in alteration of an existing process or in the start up of a new process.

The computer aided framework presented in this thesis can ease the job of the process engineer (or engineers) actually carrying out the preliminary design task on request from management. The task the engineers is performing can be described as the qualified selection among the many options for designing the process. The idea is not that this can be done in a completely automatic manner with the framework. Rather, the framework will assist, through user interactions, in generating designs and after that, in screening among the alternatives, so that only the feasible candidates are considered in the final evaluation.

The following chapter (chapter 2), presents the theoretical basis for the process synthesis framework along with the current state of the art. In chapter 3 the individual components that provide the building blocks for the integrated framework are described and details on an algorithm which was developed as part of this thesis, for the design of distillation columns, is given. Chapter 4 provides the full picture of the integrated framework for process synthesis. In doing this, it also presents a detailed algorithm for the generation of process flowsheets and superstructures. In chapter 5 the use of the developed framework is illustrated via a series of application examples. Finally chapter 6 presents conclusions and directions for future developments of the framework.

THEORETICAL BACKGROUND

2.1 Introduction

Process synthesis can be categorized into a number of different areas that are all part of synthesizing a manufacturing process and can be looked at individually or simultaneously. The common objective is to determine feasible (and preferably optimal) configurations in terms of selection of equipment and conditions of operation for the parts or aspects of the process, which are being considered. A chemical or pharmaceutical manufacturing process can be divided in terms of the different types of operations to be performed, for example, into reaction, separation and utility operations. Browsing through literature in the process synthesis area, it can be noted that this division is also the basis for the different research areas in process synthesis. These areas can be listed as:

- Synthesis of reactors and reactor networks
- Synthesis of separation schemes
- Synthesis of Heat exchanger networks (HEN). This field has evolved into the more general process integration, primarily initiated by the work of Papoulias and Grossmann (1983) and El-Halwagi and Manousiouthakis (1989).

Note that utility operations is not limited to heat exchange but also includes compressing, pumping and others. Finally, in the area of flowsheet synthesis some or all of the above process synthesis areas are treated either sequentially or simultaneously.

Common to all of the synthesis areas is that the first task would be gathering of information, for example, knowledge about properties of the compounds involved, even though the type of properties and the accuracy needed may differ for the different applications. Also, in order to carry out a selection of the equipment to be used in a process and to model the consequences of such a selection, knowledge about the function of the equipment, how to size it and the normal operation are needed.

Biegler *et al.* (1997) lists the basic steps in flowsheet synthesis as:

1. Gathering information
2. Representation of alternatives
3. Assessment of preliminary design
4. Generating and searching among alternatives

The following sections aim at giving an overview with respect to the available methods and algorithms within process synthesis and present the current state of the art. Furthermore the knowledge and tools needed in other to accomplish the above listed steps for process synthesis is described.

2.2 Flowsheets

Diagrams or figures of flowsheets are used in many areas of science for different applications (for example, to illustrate the flow of data in computer science). In this thesis flowsheets are used to represent manufacturing processes, typically chemical or pharmaceutical processes. The basic objects in a flowsheet are units (unit operations), represented by symbols as shown in figure 2.1 and connections (stream flows) represented by lines usually with arrows indicating the flow direction.

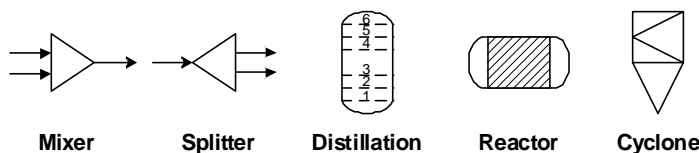

Figure 2.1: Example of unit symbols representing unit operations (equipment)

The connections can either connect two units, thereby indicating a mass flow or energy flow or both between the units. If only connected in either their endpoint or starting point, an inlet stream or an exit stream, respectively, is indicated. A dashed line is often used to indicate information flow in the flowsheet. Furthermore a connection is implicitly representing a state. The definition of state includes quantitative intensive and extensive properties, i.e., temperature, pressure, heat content and mass flow. The state, however, is not limited to quantitative information but can also be used to include qualitative information as proposed by Papalexandri and Pistikopoulos (1996). The qualitative information usually includes the name of the components that are present in the stream, but may also include, for example, a heat exchange label (hot or cold stream). If desired, the state associated to the stream, can be highlighted by a circle (see figure 2.2).



Figure 2.2: Two different representations of a connection, to the right the state associated to the stream is indicated by the number '3', which can then be used for reference for example in a table.

A major part of this thesis deals with computer aided tools and algorithms for flowsheet (or superstructure) generation, which involves more than just creating a flow diagram consisting of stream and unit objects. Rather, the tools assist in selecting the objects (equipment) for the flowsheet and for deriving the specifications for these objects.

2.2.1 Representation of superstructures

A flowsheet superstructure is an 'extended flowsheet', where compared to conventional flowsheets, the extension is the ability to represent different flowsheet alternatives for the process in the same figure. Consider for example, the case where for a given process, the best selection has to be made among two different reactors. By the use of logical (or virtual) splitters, the superstructure is able to represent two flowsheets each including one of the two reactor alternatives. Logical splitters exist only in the context of the superstructure model not physically in the process. In the model, the splitters have one or more integer (usually binary) variables assigned to them, these variables are used to indicate which connection from the splitter is part of the current flowsheet. When a value is assigned to all the logical splitter variables of the superstructure, the superstructure model represents one (current) flowsheet. The principle of logical splitters is illustrated in figure 2.3(a) where it is seen that when the binary variable y_i is true the corresponding connection is open. In figure 2.3(b) a logical splitter is used in the superstructure with two reactors described above.

Often, process flowsheets and superstructures are represented by the use of either a state task network (STN) or a state equipment network (SEN). While a SEN is similar to the flowsheets consisting of unit symbols and connections as described in the previous section, the STNs show the individual tasks to be performed in the process as part of the flowsheet. A task is for example a reaction of chemical A and B in order to produce C or separation of chemical C from a mixture of A, B and C. In addition to the network an assignment of task to equipment is needed. Often, when mathematical problems for optimization are to be formulated and solved in a purely equation oriented manner, the STN and SEN representations are particularly useful in order to define the process flowsheet in the mathematical problem formulation. A comparison between the STN and SEN representation and transforming these into mathematical problems are given by Yeomans and Grossmann (1999). Here the authors conclude that for large sequences of distillation columns, using STNs result

in the most efficient problem formulations, especially when considering heat integrated systems.

2.3 Process synthesis

In section 2.1 it was suggested that a chemical or pharmaceutical manufacturing process can be divided into reactions, separations and utility operations. This division corresponds closely to the lower three levels in the decision hierarchy proposed by Douglas (Douglas, 1985), where the decisions to be made in process synthesis is decomposed into 5 levels, starting with the decisions with the biggest influence on the design:

Level 1 Batch versus continuous

Level 2 Input-output structure of the flowsheet

Level 3 Reactor and recycle structure of flowsheet

Level 4 Separation system synthesis

a Vapor recovery

b Liquid recovery

Level 5 Heat recovery network

Reviewing a wide range of the available literature in process synthesis clearly shows that the three research areas in synthesis (listed in section 2.1) has formed

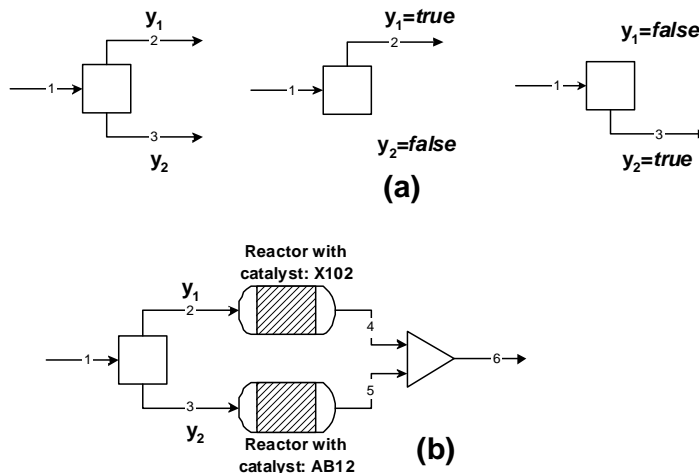

Figure 2.3: (a) Principle of logical splitters. (b) Use of logical splitters to select between two reactors using different catalysts.

the basis for different disciplines or fields in the process synthesis literature. The following subsections reviews literature within these fields. Parts of this literature, which has evolved over the past two decades is interdisciplinary, often leading towards a focus on process integration. Furthermore, methodologies capable of considering more than one of these fields has been presented as frameworks for flowsheet synthesis.

2.3.1 Synthesis of reactors and reactor networks

The design and operation of the reactor (network) has a huge impact on the design of the entire process, since the reactor effluent determines if recycle of raw materials are needed and what downstream processing is necessary in order to separate products from byproducts etc. Note that the important starting point for reactor synthesis and determination of reactor effluent is the chemistry (stoichiometrics and kinetics) of the involved reactions. Biegler *et al.* (1997) states the reactor synthesis problem as:

For given reaction stoichiometry, rate laws, a desired objective, and system constraints, what is the optimal reactor network structure and its flow pattern? Where should mixing, heating, and cooling be introduced into the network?

Research in the reactor synthesis area ranges from heuristics often incorporated in expert systems for reactor selection and sizing (as for example in the system described below by Schembecker *et al.* (1995)) to algorithms for the synthesis of reactor networks by structural optimization, for example by Balakrishna and Biegler (1992).

A method used often in reactor synthesis is the attainable region analysis, which is the calculation of a region in the composition space which is attainable for the specific type of reactors considered, introduced by Horn (1964). Methods for construction of attainable regions have been presented by, among others, a geometric approach by Glasser *et al.* (1987) and an algorithm by Hildebrandt and Biegler (1995). A valuable feature of attainable regions are that they are convex and that an optimal reactor network (consisting of the reactor families analysed) must lie within the region. Therefore, the analysis can be used to identify optimal solutions for simple systems where the dimensionality allows for graphical representation and it can provide useful bounds for the solution of mathematical optimization problems for the synthesis of reactor networks. This concept was used among others by Balakrishna and Biegler (1992) in mathematical programming formulations for solving reactor synthesis problems of varying difficulty. Kokossis and Floudas (1994) presents a very comprehensive superstructure approach used for solving a number of different reactor synthesis problems.

Examples of expert systems for reactor selections are those developed by Krishna and Sie (1994) and Schembecker *et al.* (1995). The former presenting a very comprehensive study divided into three strategy levels (catalyst design,

injection and dispersion strategy and choice of flow regime), the latter presenting a computer tool (READPERT) consisting of four modules, where the level of detail for the designed reactor builds up gradually. The methodologies presented in both these papers are a combination of heuristics and some numerical calculation. It seems, however, that both could have benefitted from integration with the mathematical programming approaches of Balakrishna and Biegler (1992) or Kokossis and Floudas (1994).

2.3.2 Separation system synthesis

The separation synthesis problem can be stated as:

Given: a) Specification of the mixture to be separated. b) Desired products and purities. c) List of potential separation techniques.

Determine: A) Separation tasks and techniques. B) Sequence of tasks. C) Appropriate conditions of operation.

So that the desired product purities are met and the cost of separation are minimum.

Similar formulations are given by Jaksland *et al.* (1995) and Barnicki and Fair (1990).

The well known hierarchical decision framework for process synthesis presented by Douglas (1985) is also including a separation synthesis level. This level consists of two parts, namely, vapor and liquid recovery, where heuristics and rules guide the selection and sequencing of the appropriate separation techniques and tasks. The flowsheet generated is not claimed to be the best design. A similar knowledge-based approach is presented by Barnicki and Fair (1990, 1992), where the mixture to be separated is characterized in terms of identity groups and selector/designer modules identify the favored separation methods out of the list of potential techniques. A heuristic approach for non-sharp distillation sequences is presented by Bamapoulos *et al.* (1988). Jaksland *et al.* (1995), Jaksland (1996) uses thermodynamic insights and rules rather than heuristics for selecting and sequencing the separation techniques. This method consists of two main levels. In level 1 differences in component properties are calculated as ratios for a wide range of properties, these ratios are used for initial screening among a large portfolio of separation techniques and to identify feasible separation techniques. In the second level a more detailed mixture analysis is applied for further screening. Also for separation techniques using solvents (for example extractive distillation, where an entrainer is needed), these solvents are identified using a molecular design framework adapted from Gani *et al.* (1991). After this, the second level also includes sequencing of the separation tasks and techniques.

Malone and Doherty (1995) have presented a conceptual framework primarily based on graphical tools (i.e. plotting of residue curves) and heuristics. The separation techniques considered in this framework are limited to various distillation configurations and liquid extraction. The framework consists of 6 steps

including a step for estimation of design parameters for distillation columns (for example, number of stages and reflux ratio) and a step for generating cost estimates. Similar separation synthesis frameworks, using residue curves have also been presented by other groups, for example, by Wahnschafft *et al.* (1993), Westerberg and Wahnschafft (1996) and by Bekiaris and Morari (1996). A comprehensive review of the area is given by Widagdo and Seider (1996). The application of residue curves in separation synthesis becomes difficult for systems with more than 3 to 4 compounds, due to difficulty of representing the system graphically. An approach for handling mixtures where the number of compounds makes graphical representation difficult is presented by Ahmad and Barton (1996). Recently, commercial computer aided tools have emerged and an industrial perspective to the use of graphical tools in distillation synthesis is given by Wahnschafft (1997).

As in the case of reactor synthesis, structural optimization frameworks has also been developed for separation synthesis, and the common focus has been primarily towards distillation sequences. Also, since the structural optimization approach relies on the proposal of a superstructure, use of heuristic approaches is often preceding the optimization. An example of such structural optimization frameworks is the MILP model for the synthesis of heat-integrated distillation column sequences, presented by Andrecovich and Westerberg (1985). More complex and non-linear models has been presented by among others Aggarwal and Floudas (1990). A common factor, however, is that the distillation column model and the thermodynamic model used are often not rigorous. A framework for the generation of distillation superstructures based on the decomposition idea of Douglas and the use of graphical tools is presented by Sargent (1998).

The size of the task/techniques selection and sequencing problem is determined by the number of compounds (NC) in the mixture to be separated and the number of potential separation techniques (NT). For a separation synthesis problem where all components need to be separated from each other, Thompson and King (1972) proposed the following formula to calculate the number of possible sequences:

$$NS = \frac{(2(NC - 1))!}{NC!(NC - 1)!} NT^{NC-1} \quad (2.1)$$

From Table 2.1, generated with equation 2.1, it is clear that the separation synthesis problem has a potential danger of combinatorial explosion that needs to be addressed. The problem is of special concern when the portfolio of separation techniques are large, and this is why it is an advantage to decompose the problem, as for example in the method of Douglas (1985) where the separation synthesis level has a vapor and a liquid sublevel. In the framework by Barnicki and Fair (1990), 10 different separation techniques are considered. However by grouping these into techniques suitable for vapor recovery and techniques suitable for liquid recovery, and by the use of a 'Phase separation selector' the problem size is reduced. The authors report the following example: When considering 10 separation techniques at the same time for a 6 component mixture,

NC\NT	2	4	7	10
2	2	4	7	10
3	8	32	98	200
4	40	320	1715	5000
7	8448	540672	15529668	$1.320 * 10^8$
10	2489344	$1.275 * 10^9$	$1.962 * 10^{11}$	$4.862 * 10^{12}$

Table 2.1: Number of possible sequences to separate NC components by NT potential separation techniques

there are 4200000 possible sequences (using equation 2.1). The 10 separation techniques can be grouped into 4 vapor recovery and 6 liquid recovery techniques. Now, if only the 2 intermediate boiling components are to be considered for both groups of separation techniques, the problem size reduces to 320 possible sequences for the vapor recovery and 2560 for the liquid recovery. Also, if either heuristics or property insights are used to screen out infeasible techniques the number of possible sequences decreases, as it is clearly seen in Table 2.1.

2.3.3 Synthesis of Heat Exchanger Networks and Process Integration

The task of selecting and sizing the equipment for utility operations (like heating or increasing the pressure of a stream) is quite straight forward compared to the same task for reaction and separation operations. This is at least true as long as the utility operations are treated one by one, but it becomes a different matter if one wants to integrate the utility operations with each other. Consider the case where a feed must be preheated prior to entering a reactor, and the reactor effluent must be cooled in order to perform a separation using a TP-flash (separation of vapor and liquid at constant temperature and pressure). Common sense tells us that we could exchange some of the heat removed after the reactor to preheat the feed. However, as soon as the process becomes more complex and more sources and sinks for heat becomes available in the flowsheet, the number of possible combinations for exchanging heat increases drastically, and using common sense can no longer guarantee the determination of optimal (or even near optimal) solutions to these problems. The synthesis of heat exchanger networks (HENs) is concerned with this problem, El-Halwagi (1997) states the synthesis of HENs problem as answering the following questions:

- Which heating/cooling utilities should be employed?
- What is the optimal heat load to be removed/added by each utility?
- How should the hot and cold streams be matched (i.e., stream pairings)?

- What is the optimal system configuration (e.g., how should the heat exchangers be arranged?, is there any stream splitting and mixing?, etc.)?

It was Hohmann (1971) who first showed (during his PhD under guidance of Lockhart) that determination of the minimum external utility requirements can be carried out through the use of composite heat curves (a plot of temperature versus the amount of heat to be added or removed for the combined cold or hot streams respectively). The approach leads to easy identification of the thermal pinch point and cascade diagrams which is also used in algorithms for developing effective HEN layouts. The methodology was developed further by primarily Linnhoff and co-workers (Linnhoff and Hindmarsh, 1983). Since this development many commercial tools using pinch analysis has become available and have been used for achieving energy savings. A useful industrial perspective is given by Gundersen and Naess (1988).

Designing HENs with the pinch point design approach will result in a network with the minimum utility cost, but this is not necessarily optimal when the equipment cost of the network is also taken into account. The design of HENs using cascade diagrams can be generalized through optimization techniques. A valuable starting point for this approach is the LP and MILP transshipment problems proposed by Papoulias and Grossmann (1983) for the sequential determination of minimum utility loads and minimum number of exchanger units. Furthermore, the minimum investment cost for the network can be determined through the formulation of a NLP problem, as proposed by Floudas *et al.* (1986). In order to avoid the trade-off situation of the sequential approach (minimum utility cost doesn't necessarily mean minimum investment cost) a simultaneous approach can also be employed. Examples of this are numerous, e.g., by Yee and Grossmann (1990), Ciric and Floudas (1991) and Briones and Kokossis (1999). However, many of these are still assuming constant heat-capacities, ideal thermodynamics etc, which are not valid assumptions for all systems. Attempts to eliminate some of these assumptions by introducing correlations and detailed thermodynamics, have been presented by Nielsen *et al.* (1996) who used simulated annealing. An expert system based approach for the synthesis of HENs is presented by Li and Hua (2000).

The synthesis of HENs is an example of process integration where different parts of the process is exchanging heat with each other. Another example of this could be a single distillation column where the heat removed in the condenser is exploited in the reboiler through a heat-pump (Koggersbøl, 1995). Practically all chemical processes are integrated and the integration is not at all limited to heat transfer aspects, mass transfer aspects can also be considered for process integration.

As an analogy to the pinch design method for HENs, El-Halwagi and Manousiouthakis (1989) developed the pinch design method for synthesis of Mass Exchange Networks (MENs). Instead of plotting temperature and amount of heat to be exchanged between hot and cold streams, composition and the amount of mass to be exchanged between rich and lean streams are plotted. This type of plots

provides visual identification of pinch points and is used together with algorithms for the design of MENs, in a very similar fashion as for the design of HENs. The method has been used with great success especially in waste recovery i.e. of volatile organic compounds (VOCs) and for plant-wide reduction of water consumption.

One very efficient example of process integration is reactive separation, where the reaction and separation (which is usually proceeding the reaction) is carried out together in the same column. The column would usually consist of reactive and non-reactive zone(s) and if the reaction is exothermic the heat generated can be used for the separation, thereby, reducing the heating requirements in the reboiler. Synthesis and design algorithms for reactive separation are available, often in the form of graphical tools, e.g. Barbosa and Doherty (1988); Ung and Doherty (1995), Pérez-Cisneros *et al.* (1997); Pérez-Cisneros and Daza (2000) and Hauan and Lien (1998); Hauan *et al.* (1999). Finally, Pistikopoulos and coworkers (Papalexandri and Pistikopoulos (1995, 1996); Ismail *et al.* (1999)) have presented a general framework that combines modelling and synthesis/design tasks and is particularly suitable for optimal integration of heat and mass exchange networks.

2.3.4 Flowsheet synthesis

The flowsheet synthesis problem can be described as:

Given the feed and product specifications in the process, determine a flowsheet including the required tasks, appropriate equipment and solvents needed, as illustrated in figure 2.4. The flowsheet must be capable of converting input (feed streams) to output (product streams). Furthermore, determine the design of the equipment in the flowsheet and the appropriate conditions of operation. Finally, the identified solution must be analyzed for verification.

Two groups of flowsheet synthesis problems exist: grassroot design (where the process is designed from scratch) and retrofit design. In the second type an existing process flowsheet has to be changed in order to match new objectives. In some cases the operation of the existing flowsheet is changed to satisfy the new objectives, in other cases, parts of the flowsheet must be substituted to meet the new objectives, while the rest remains fixed.

In order to provide a framework for flowsheet synthesis, the areas described in the previous sections (reactions, separation or heat-integration) are considered either sequentially or simultaneously within the same framework. Such a framework is the topic for this thesis, other examples of flowsheet synthesis frameworks are reported by, among others: Siirola *et al.* (1971), Douglas (1985), Duran and Grossmann (1986b), Balakrishna and Biegler (1993), Srinivas and El-Halwagi (1994), Schembecker and Simmrock (1995) and Papalexandri and Pistikopoulos (1996).

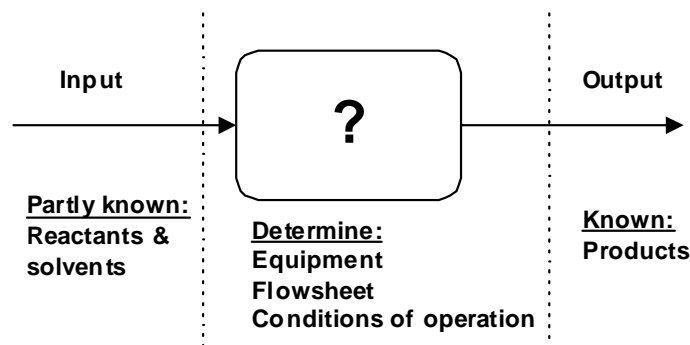

Figure 2.4: In the flowsheet synthesis problem the input and output is known, the rest is to be determined.

2.3.5 Integrated approach

Jaksland (Jaksland, 1996) classified the existing methodologies for process synthesis into three categories:

- a) Those that employ heuristics or rules of thumb from an experienced engineer
- b) Those that employ mathematical or optimization techniques
- c) Those that employ thermodynamic/physical insight

This corresponds also to the divisions of the reported literature in sections 2.3.1-2.3.3. While application of typical frameworks of type a) and c) or a combination do not seek to report optimal flowsheets, mathematical (structural optimization) techniques that claim to determine optimal flowsheet are limited by the availability and application range of the model and/or the superstructure.

If methodologies of the three types can be integrated into one framework, their combined use allows for exploitation of the strengths of each methodology, while compensating for the weaknesses, for example, a designed flowsheet which is a result from a methodology of type c) and which is not necessarily optimal can be used as a good initial estimate for a method of type b). It can be argued that this can also be achieved by first applying method c) and then using the result to set up the problem for a method b) type framework. However, by providing an integrated environment for these techniques, data does not need to be transferred manually, thereby eliminating some tedious work and reducing the overall time used to solve the problem.

Some examples, other than this thesis, of flowsheet synthesis frameworks incorporating multiple techniques are Daichendt and Grossmann (1997) who combined hierarchical decomposition with mathematical programming, while

Kravanja and Glavic (1997) integrated pinch analysis with mathematical programming for the synthesis of HENs. Also, as mentioned earlier, Papalexandri and Pistikopoulos (1996) also employ combined methodologies.

2.4 Tools and resources for Process Synthesis

The success of effectively solving process synthesis problems in an integrated manner depends on the availability of certain tools and knowledge resources. This section describes the type of knowledge needed and some of the tools available, which are used in the integrated framework for process synthesis developed in this thesis.

2.4.1 Compound properties

The need for pure component properties as well as modeling of mixture behavior are widespread in process synthesis, examples are:

- Starting with a list of separation techniques that may be applicable for a specified separation problem, thermodynamic insights in the form of analysis of pure component properties, binary mixture properties and multicomponent mixture properties can be used in order to eliminate infeasible (or obviously inefficient) separation techniques for the specified separation problem.
- The generation of residue curve maps, which may be used in the synthesis of separation systems, depends on the availability of a valid model for prediction of phase-equilibria.
- For the simulation and optimization of chemical processes pure compound and mixture property data is needed.

Generally, there are two ways of obtaining knowledge about properties, namely through property databases (containing experimental data) or through various types of property prediction models (which are applying parameters derived from data or other properties in correlations).

Databases and literature (only a selection are mentioned below):

- The DIPPR databank (Daubert and Danner, 1989) contains pure component data for more than 1500 compounds, the type of data ranges from critical properties, phase transition properties to molecular size data. Part of the data are available in correlations as a function of temperature.
- Environmental health and safety (EH&S) data for pure compounds are available through the CHRIS (Silver Platter Information Inc., 1998a), HSDB (Silver Platter Information Inc., 1998b) and RTECS (Silver Platter Information Inc., 1998c) databases.

- Journal of Chemical and Engineering Data publish primarily experimental pure component and mixture properties data.
- The CAPEC database (Nielsen *et al.*, 2000) has a wide range of pure and mixture data available.

Property prediction, pure component properties:

Methods for prediction of pure component properties can generally be classified into two types: 1) Primary properties – predicted only from the molecular structure information and 2) Secondary properties – where other properties are used in a correlation. Methods which have been used for this thesis are:

- Methods based on the group contribution approach (GCA). The compounds are expressed as functions of number of occurrences of predefined fragments (groups) in the molecule, i.e.:

$$T_b = f\left(\sum_i c_i C_i\right) \quad (2.2)$$

where T_b is the normal boiling point and c_i , C_i are the number and contribution of group i respectively. GCA methods have been developed by among others: Joback and Reid (1987), van Krevelen (1990) and Constantinou and Gani (1994). The predicted properties are typically critical properties, phase transition properties, formation energies and molar volumes. Contrary to most other GCA methods, the method of Constantinou and Gani (1994) is capable of distinguishing between some forms of isomers.

- A wide range of methods based on correlations of other properties (usually properties like the critical properties, the normal boiling point and the molar volume) are available. Good sources for correlations are Poling *et al.* (2000) and Lyman *et al.* (1990).

A computer program called ProPred (Nielsen *et al.*, 1999) for easy utilization of some of the prediction methods described above has been developed at CAPEC, located at the Department of Chemical Engineering, Technical University of Denmark.

Property prediction, mixture properties:

Models for prediction/calculation of mixture properties can be classified into:

- Equation of state (EOS) and activity coefficient models. These models consist of equation(s) which contains parameters, and the value of these parameters are estimated from experimental mixture property data. Examples of such methods are the Soave / Redlich / Kwong (SRK) EOS (Soave, 1972) and activity coefficient models as: Wilson (Wilson, 1964), NRTL (Renon and Prausnitz, 1968) and UNIQUAC (Abrams and Prausnitz, 1975).

- Methods based on the GCA. The most well known example of these methods are the UNIFAC method (Fredenslund *et al.*, 1977), where the interaction among the compounds in the mixture is accounted for by structural fragment contributions. These contributions are also based on experimental data but not necessarily for the compounds in question.

In order to guide the selection of an appropriate mixture property model, a computer program called TMS (Gani and O'Connell, 1989) can be used. Furthermore, for the estimation of the interaction parameters in mixture models TML-EST (Nielsen and Gani, 2000) has been developed.

2.4.1.1 Molecular design

Separation techniques based on the use of mass separating agents (solvents) are often part of the solution to separation synthesis problems. Therefore, a tool for finding or designing potential solvents is needed, so that these solutions can be explored. Tools implementing Computer Aided Molecular Design (CAMD) techniques is often used in design of solvents. The basic problem solved with such techniques can be stated as:

Given: Desired properties of the molecules to be designed and a selection of molecular fragments to be used as building blocks.

Determine: Feasible molecular descriptions with the desired properties.

Molecular design techniques can be divided into three categories:

- Mathematical programming techniques, presented by among others, Odele and Macchietto (1993), Vaidyanathan and El-Halwagi (1994), Duvedi and Achenie (1996) and Pistikopoulos and Stefanis (1998).
- Stochastic optimization techniques, reported by Marcoulaki and Kokossis (1998) and Venkatasubramanian *et al.* (1995).
- Enumeration (generate and test) techniques, are by presented by Gani *et al.* (1991), Pretel *et al.* (1994) and by Friedler *et al.* (1998).

A review of molecular design techniques is provided by Harper and Gani (2001). The molecular design technique used in this thesis is the multi level generate and test type method of Harper *et al.* (1999). Molecules are generated from fragments (groups) using a rule based combinatorial approach guaranteeing that only feasible compounds are formed. The lower levels generate simple molecular representations (e.g. group vectors) while the higher levels use the results from the previous levels to generate molecule descriptions with a high level of detail (e.g. 3-dimensional structures). Between each level, the design constraints are evaluated and only compounds fulfilling the property constraints are allowed to continue to higher levels. This methodology allows for the use of the generate and test approach without suffering from combinatorial explosion

but obtaining additional structural information in the generated structures. The methodology has been implemented in a computer tool called ProCAMD (Harper and Hostrup, 1998).

2.4.2 Simulation and optimization

Simulation of unit operations and process flowsheets, has been carried out ever since computers became available to chemical engineers. One might argue that calculations were performed even before computers became available, but all practical process simulation problems are solved with the aid of computers today. Simulation of process flowsheets is carried out by solving mathematical models of the process. Flowsheet simulation can be performed with either a steady-state approach (calculating a steady operation point of the process) or a dynamic approach (process behavior as a function of time). Furthermore different strategies can be applied to solve the model equations, for example, for steady-state simulation the sequential modular approach or equation oriented approach may be used. In the former the calculation of each unit and the task of converging the overall balance equations by using tear stream(s) are done separately, while for the latter equations for all units and the overall balances are solved simultaneously with one common solver.

Computer tools for flowsheet simulation have been available for many years, most commonly used are commercial simulators like HYSYS (Hyprotech Ltd.), ASPEN-PLUS (Aspen Technology Inc.), gPROMS (Process Systems Enterprise Ltd.) and PRO-II (Simulation Sciences Inc.). However, many chemical manufacturing companies as well as academic research groups still use their own in-house simulators. The flowsheet simulator primarily used in this thesis is a steady-state simulator called ICASSim, which has been developed by CAPEC. An NLP-optimizer has been integrated into this simulator, furthermore, customization is possible since the source code is available within CAPEC.

2.4.2.1 Optimization

The problem solved with optimization can be described as (Biegler *et al.*, 1997):

Given a system or process, find the best solution to this process within a specified set of constraints.

To solve a problem like this, a measure of what is the best solution is needed. Therefore an objective function is defined for the problem, usually a mathematical expression, related to the yearly cost or profit for the process. The outcome of solving an optimization problem is the optimal value for certain (decision) variables, some of them (dependent variables) may however be bounded to lie within the defined constraints of the problem. A general mathematical form of

the process optimization problems can be written as:

$$\begin{aligned}
 & \min f(\bar{x}) \\
 \text{s.t.:} & \\
 & g(\bar{x}) \leq 0 \\
 & h(\bar{x}) = 0
 \end{aligned} \tag{2.3}$$

where \bar{x} is a vector of continuous variables (the decision and dependent variables), $f(\bar{x})$ is the objective function, $g(\bar{x})$ and $h(\bar{x})$ are vector of inequality and equality constraint functions respectively.

If the equations are all of linear type, the resulting optimization problem is called a Linear Program (LP), and methods for solving LPs effectively are readily available (i.e. the simplex method). Usually, however optimization problems for process flowsheets contains non-linear equations, thereby resulting in non-linear programs (NLPs). In order to solve NLPs certain techniques must be applied, for example reduced gradient approaches or a Successive Quadratic Programming (SQP) method (see Biegler *et al.* (1997)). Solutions to NLPs must satisfy certain conditions, developed by Karush (1939) and further by Kuhn and Tucker (1951), known as the first and second order Karush-Kuhn-Tucker (KKT) conditions. However, the methods for solving NLP's cannot guarantee that the solution found is globally optimal, unless the objective function and the feasible region is convex. The NLP-optimization method used in this thesis is a modified SQP algorithm by Bossen (1995), which has been implemented in ICASSim (Henriksen and Støyt, 1999).

2.4.2.2 Optimization with discrete decisions

Part of solving a process synthesis problem is to determine which equipment should be used in the process. If more than one alternative exists for a particular operation in the process a decision of which alternative to use must be made. Such decisions/selections among alternatives can be included in the optimization problems, the general problem form can be written as:

$$\begin{aligned}
 & \min f(\bar{x}, \bar{y}) \\
 \text{s.t.:} & \\
 & g(\bar{x}, \bar{y}) \leq 0 \\
 & h(\bar{x}, \bar{y}) = 0
 \end{aligned} \tag{2.4}$$

where \bar{y} is a vector of integer (often boolean) variables and the other symbols are the same as in equation 2.3. Graphical representation of flowsheets with decision variables are possible through the use of superstructures (see 2.2.1).

In the case where the optimization problem consists of only linear equations the resulting problem is a Mixed Integer Linear Program (MILP). A MILP can be seen as a number of LPs, one for each feasible combination of the integer \bar{y} variables. MILPs are effectively solved with branch and bound methods, where

the solution space of integer variables is scanned through *search trees*. The optimal solution in the tree is found by comparing the objective function from the solution of the LPs that comes from fixing the integer variables. There are different strategies available for solution of MILPs and complete enumeration of all LP solutions can generally be avoided.

If the optimization problem contains non-linear equations and discrete variables the resulting problems are called Mixed Integer Non Linear Programs (MINLPs). The solution of such problems involve the solution of MILPs and NLPs sequentially. Two available methods for this are the Generalized Benders Decomposition (GBD) and the outer-approximation method. To improve the robustness of solving MINLP flowsheet problems, Grossmann and Kocis (1989) introduced the Modeling and Decomposition (M/D) strategy by which, at each NLP step only the existing units are optimized rather than the entire superstructure. This way, all NLPs become smaller and effects of non-convexities and singularities are significantly reduced.

Grossmann and Daichendt (1996) provided a review on the use of optimization approaches in process synthesis.

2.4.3 Integrated environment

In order to have the proper frame for the integrated computer aided process synthesis framework an integrated environment, that allows for easy and effective data transfer and sharing among the different tools used, is needed. Gani *et al.* (1997) has presented an Integrated Computer Aided System (ICAS), and the concepts of this system fits very well to the needs for the process synthesis framework. ICAS is being developed at CAPEC, the various features available at the present state are:

- Central user interface. Here the problem is defined and the flow of data is controlled from here. This means, that the various tools and algorithms that are part of ICAS are called from here and data is passed to and received from them.
- Database, DBEngine and DBManager. The relational database contains a variety of data, including: Pure compound properties, binary interaction coefficients, structural group descriptions of molecules and experimental equilibrium data. The DBEngine module handles communication between the database and all other tools of ICAS, thereby making sure that the same thermodynamic data is used everywhere. DBManager is used mainly for maintaining (updating) the database.
- TMLLib – is module for thermodynamic calculations (fugacities, activity coefficients, flash calculations etc.). Other tools of ICAS use this module for their thermodynamic calculations.
- Utility calculations. This tool takes as input the identity of the selected compounds, composition, temperature and pressure. It provides a num-

ber of useful calculations through an user interface, among which are: Flash calculations, calculation of pH, physical equilibrium diagrams, separation efficiency diagram and others.

- Tools for property prediction and estimation. ProPred is used for drawing molecules and prediction of a number of pure compound properties. The predicted values can be exported to the database, thereby ProPred is providing a useful way of introducing new compounds into the database. TML is a tool for estimation of binary interaction coefficients.
- MoT – Modeling Testbed. This tool provides an easy way of entering equation based models. The models, which may contain differential equations, can be analysed and solved and also exported, so that they can be called from other tools.
- ICASSim – is a steady-state simulation engine and which have a NLP-optimizer build in.
- Dynsim – is the dynamic simulation engine and which have certain control features build in.
- The control toolbox can be used for obtaining a linear model of a dynamic model. The linear model can then be used in analysis and tuning of controllers.
- The synthesis and design tools is the framework developed in this thesis. ProCAMD, a tool for computer aided molecular design, is also part of the design tools. ProCAMD was not developed as part this thesis.

ALGORITHMS AND TOOLS

3.1 Introduction

The complete task of planning and of designing a chemical or pharmaceutical process is in most cases, either of the grassroot type or the retrofit type. A number of steps and activities need to be performed, involving many people who needs to collaborate.

In this chapter, the general problem to be solved with the developed integrated process synthesis framework is formulated and the use of the framework in various design tasks is highlighted.

The main idea behind the developed framework is the utilization of a number of different algorithms and tools in an integrated manner. The algorithms and tools which have been developed in this thesis as part of the integrated framework are:

- Reaction analysis.
- Separation synthesis algorithm, a further development of the algorithm by Jaksland *et al.* (1995).
- Process design, an algorithm for the design of distillation columns.
- Flowsheet generation
- Structural optimization

These are described in detail in section 3.3 together with integration aspects highlighting the data-flow and work-flow. The complete picture of the integrated process synthesis framework is given in chapter 4.

3.2 Problem formulation

Biegler *et al.* (1997) labels the process of converting an abstract description into a more refined description a synthesis activity. This could be the process of going from the simple desire to produce a certain product to the goal

of having a preliminary design ready. Several synthesis activities need to be carried out in the life cycle of a chemical manufacturing process. One such activity is the creation of a preliminary process design which typically follows immediately after a decision from executive management to investigate the potential of a specific project. For example, create a preliminary process design to increase the production capacity at one of the existing sites of production of the company. Another synthesis activity takes the result from the preliminary process design as input and creates a much more detailed design, i.e. in the form of a piping and instrumentation diagram (P&ID). In this thesis the focus is on an integrated framework that can be used for preliminary process design, and when the term synthesis is used, it is generally the activity of creating a preliminary process design that is referred to.

If the preliminary process design task was initiated from company management, the ultimate goal for the employees carrying out the design task is to produce a report that will allow the management to evaluate whether the project should be continued. The report typically includes a financial analysis, possibly with scenarios to illustrate the flexibility (i.e. to meet changes in raw material and product prices). Furthermore it may include operational, maintenance, environmental, health and safety aspects. In addition to such a report there may be several other issues that will be addressed, and which is needed at later stages of the project and in other projects, such as:

- A process flowsheet diagram (PFD) with stream summary.
- Preliminary design for the equipment, i.e., equipment design and sizing parameters.
- Operating parameters - i.e. operating temperature and pressure, reflux ratios for distillation columns, purge fractions, utility (heating and cooling) requirements.
- Constraints or requirements for equipment that must be considered when making detailed equipment design.
- Operational constraints, which may be due to a number of different reasons such as feasibility of the process, thermal decomposition of compounds and many more. Such constraints must be taken into account when designing the control system and developing the operating instructions.
- Various data, for example property data which, if archived properly, can be used if the process has to undergo a retrofit design later as well as in other projects involving the same or similar compounds. Another example is EH&S data which must be available when working out operator instructions and training.

The preliminary process design task involves a number of steps, starting with transforming the expressed desire from management into a problem formula-

tion. This is followed by a conceptual design phase (often involving brainstorming sessions) where the basic concepts for the process are established. Next step is to create a base case design for the process and in extension to this generate alternatives. Further steps involve analysis, comparison of alternatives (to the base case) and optimization. Typically, a synthesis group with a responsible leader carries out the preliminary process design task. The group may be a fixed team or more likely put together for the specific project, based on the former experience of the team members. The team may use experts to handle specific design aspects. Both the synthesis group as well as the experts typically use a number of different computer aided tools in order to accomplish the steps of the design task. If the tools are integrated with each other so that the design task becomes one project where data is shared, collaboration becomes easier and a significant amount of project time is saved. Figure 3.1 highlights the links between the activities to be carried out for the design task, the roles of the different people involved and the possible application of computer aided tools.

The problem formulation, of course, depends heavily on the objective for the design task given by the business unit who initiated the task. However, most problem formulations for preliminary design tasks will have common parts and subtasks. Therefore, a general framework for handling problems formulated in this way, would be useful for solving all the preliminary design tasks. A typical problem formulation for a grassroots type of design task could be:

Goal: Develop an optimal process design for producing m kilograms of product X per year.

Start by developing the general concepts for the production: Find possible reaction routes – if not already fixed/discovered by the company's chemist(s); consider the general principles to be used for separations (i.e. should they only be based on distillation); consider recycle issues; heat/mass integration; pollution issues.

Find and explore existing and similar solutions in literature and other sources.

Along with the reported optimal design, other promising alternatives should also be presented, if found.

The reported solution(s) must be analyzed subject to standard company procedure.

The work-flow illustrated by the activity diagram in figure 3.1 fits well to this type of problem formulations, and design problems are solved when a corresponding set of algorithms and tools are available. Once a base case design is developed, the next step typically involves solving an optimization problem. The type of the optimization problem, depends on the complexity of the models used and whether discrete decisions are included in the formulation

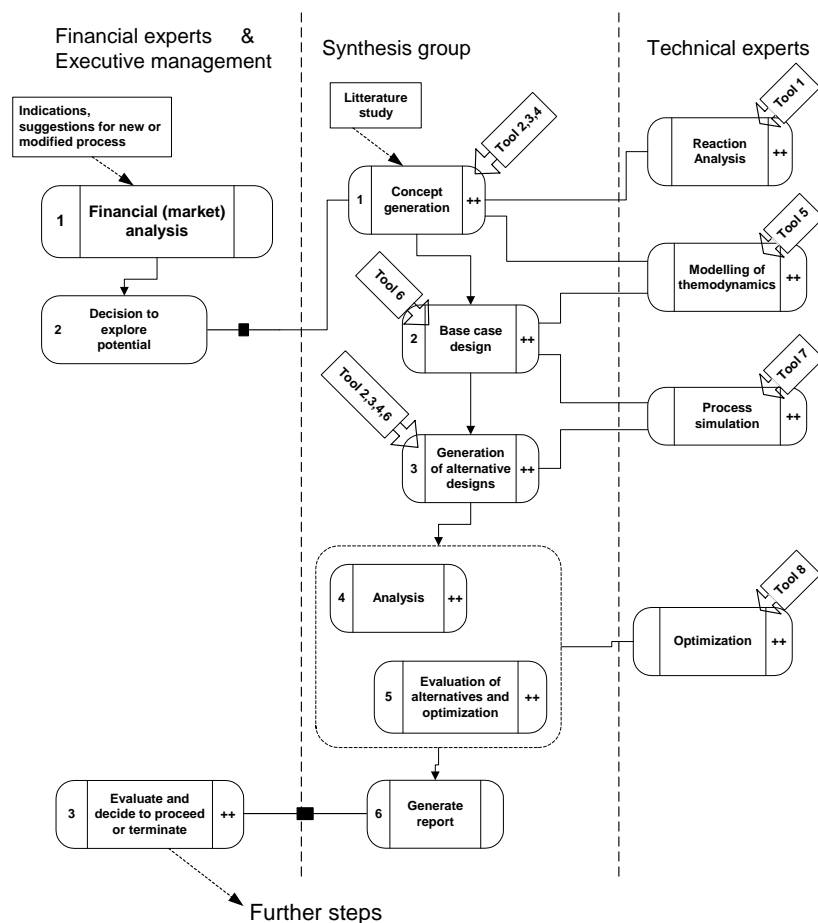

Figure 3.1: Activity diagram for the synthesis of a preliminary design. The computer aided tools, have the following functions: 1. Reaction analysis; 2. Process synthesis (guidance in equipment selection); 3. Utility tools - calculation of phase behavior; 4. Calculation of residue curves; 5. Thermodynamic model estimation; 6. Process design - tool for column design etc.; 7. Process simulator; 8. Continuous and structural optimization facility

of the optimization problem. The optimization problem may be formulated as a mathematical programming problem, where for the most complicated case, the problem may include non-linear elements as well as discrete decisions:

$$F_{OBJ} = \min \{C^T \mathbf{y} + f(\mathbf{x})\} \quad (3.1)$$

s.t.

$$h_1(\mathbf{x}) = 0 \quad (3.2)$$

$$h_2(\mathbf{x}) = 0 \quad (3.3)$$

$$l_1 \leq g_1(\mathbf{x}) \leq u_1 \quad (3.4)$$

$$l_2 \leq \mathbf{B} \mathbf{y} + \mathbf{C} \mathbf{x} \leq u_2 \quad (3.5)$$

In the above equations, \mathbf{x} represents the vector of continuous variables (such as flowrates, condition of operation, design variables, etc.), \mathbf{y} represents the vector of binary (integer) variables, $h_1(\mathbf{x})$ represents the set of equality constraints related to continuous process design specifications (i.e., column pressure), $h_2(\mathbf{x})$ represents the set of equality constraints related to the process model equations (i.e., mass and energy balance equations), $g_1(\mathbf{x})$ represents the set of inequality constraints (process design specifications). The binary variables typically appear linearly as they are included in the objective function term and in the constraints (Eq. 3.5) to enforce logical conditions. The term $f(\mathbf{x})$ represents a vector of objective functions that may be linear or non-linear depending on the definition of the optimization problem.

3.2.1 Design problems including selection of solvents

In the mathematical problem formulation, equations related to solvent design and selection can be added to the existing set of equations:

$$h_3(\mathbf{x}) = 0 \quad (3.6)$$

$$l_3 \leq g_2(\mathbf{x}) \leq u_3 \quad (3.7)$$

Often, separation techniques using solvents (MSAs) need to be considered for the process design solution, and therefore, a suitable solvent has to be found as part of the design task. For some design tasks, even the main objective can be to consider retrofit design of part of a process with a solvent based separation only. For example, a common problem in process industry, is the removal of a chemical species from an azeotropic (or close boiling) mixture. The need to solve problems of this type can be a consequence of environmental restrictions such as removal of a pollutant prior to discharge. When this is the case, the solutions of the problem also need to consider environmental constraints. An example of this type is described by Hodel (1993), where toluene was used as solvent for the removal of phenol from water by liquid-liquid extraction. Due to environmental restrictions towards toluene the process had to be modified

and the solution was to replace toluene with a more environmentally benign solvent. Generally, two different approaches can be applied for finding solvents, solvent database lookup or molecular design (see 2.4.1.1).

In the above equations (3.6 and 3.7) $h_3(\mathbf{x})$ represents the set of equality constraints related to solvent design and $g_2(\mathbf{x})$ represents the set of inequality constraints with respect to property constraints related to solvent design and environmental constraints. Two different approaches can be applied in order to incorporate solvent design related equations into the optimization problem. They can either be treated separately (Harper *et al.*, 2000) or they can be included as part of the overall synthesis and design of the process and solved simultaneously as an integrated design problem where the whole life cycle of the system and the environmental impacts incurred in different stages are considered (Pistikopoulos and Stefanis, 1998).

Obtaining properties related to environmental considerations often involves use of databases that are currently not at a state where automatic lookup is possible. Therefore, for this problem type, it may be an advantage to treat the solvent design related problems separately. These can be studied separately from the overall design problem if they do not affect other parts of the process flowsheet and/or if the objectives are only to satisfy the environmental constraints and not to minimize the environmental impact. Since the removal of a chemical species from a process stream satisfy this criteria, such a separation problem becomes an additional sub-problem that may be solved separately. As an additional sub-problem, it contributes with additional operational and investment costs to the total process. Therefore, there is an incentive to find an optimal solution to this sub-problem even though better results may be obtained through the solution of an integrated design problem because the optimal solution from the sub-problem serves as a good initial estimate for the more complex integrated design problem.

The problem being solved in the above scenario is usually classified as pollution prevention by substitution. Consider the following – phenol needs to be removed from the waste water because of environmental reasons. However, because of environmental reasons, toluene which is used, as the solvent must be substituted by another environmentally more benign solvent. Note that the above scenario did not question how phenol (chemical A) came in the waste water stream. There could be many reasons for its presence in the waste water stream. For example, it could have come in with the raw material as an impurity, it could have been produced as a by-product in a reactor, or it could have been introduced as a solvent. If one identifies the reason why chemical A is present in the stream, the problem formulated to remove it could be different. For example, pre-treatment of the raw material or choice of another reaction path are alternatives that could be considered for the synthesis of the optimal total process flowsheet. Synthesis and design of the total process flowsheet, may however, recommend the removal of chemical A from the waste water stream. In this case, typical pollution prevention/cure problems is solved as a sub-problem of the larger synthesis and design problem involving the total

process flowsheet.

3.3 Algorithms and tools for process synthesis

3.3.1 Reaction analysis tool

Since chemical reactions play a central role in process flowsheets, a reaction analysis tool has been developed as part of the integrated process synthesis framework. Knowledge about chemical reactions and especially their kinetics is essential when it comes to reactor optimization but also in flowsheet synthesis and optimization in general. In fact, efforts in new process development are often centered on the chemical reaction system. The tool developed here concentrates mainly on obtaining the kinetic model rather than the synthesis/development of specialized reactors for the specific process. It therefore provides the necessary entry point (the kinetic model) for working with process synthesis problems including reactions. Optimization of configurations with standard reactor models (batch, CSTRs, PFR) is possible within the tool, however if reactors within a flowsheet or reactors with specialized models are to be studied, the tool must be used in an integrated environment with modeling and optimization facilities.

Figure 3.2 provides an overview of the different components related to the reaction analysis tool.

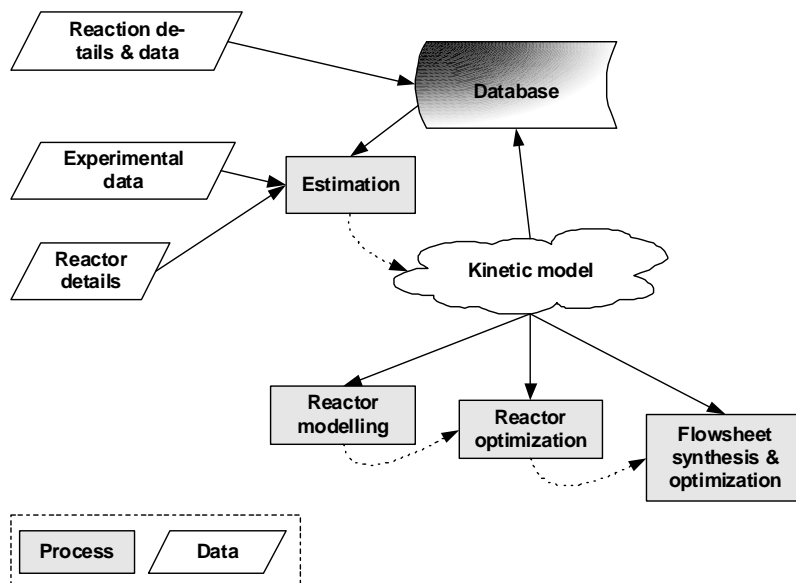

Figure 3.2: Reaction analysis tool – overview.

As can be seen (figure 3.2) the kinetic model is obtained from estimation. Before estimation can be carried out, the following information must be available:

- Reaction data and details – Primarily stoichiometric coefficients but also thermo physical data (for example if some reactions are to be considered at equilibrium).
- Experimental setup – Characteristics for the experiments carried out. Details for: The reactor where the experiments were conducted, the measurements (for example, are some concentrations measured together?), is there more than one phase?
- Experimental data. The actual measured values but also the weighting of the experiments.

Furthermore, a hierarchically structured relational database has also been developed as part of the reaction analysis tool, the format is open and can easily be used from other tools (a description is given in the next subsection). Once a satisfactory kinetic model has been obtained it can be used for other activities (reactor modeling and optimization as well as flowsheet synthesis and optimization).

3.3.1.1 Reaction database structure

The reaction database has been designed with generality in mind, so that it can serve as a common knowledge base for reaction related knowledge. The implementation was carried out in a relational database environment with open standard interfaces. This makes it easy for any tool to access the database. The reaction database has a very detailed representation of reaction chemistry and in order to facilitate communication between different types of users (for example the chemist conducting the experiments and the optimization expert) for almost every type of data stored, extra information (i.e. a text note) can be stored with it. This also helps in preserving company knowledge. In the reaction analysis tool, the database is used to store all general reaction data. Another obvious use for the database is as a server of knowledge for a reaction browser, where the user could browse for pathways to a specific product etc.

The knowledge representation is based on fundamental and derived information as shown in figure 3.3. The fundamental objects are the compounds, reactions, catalysts and conditions. The compound object contains information about the chemical species, this can be the same type of information as a compound object in a typical compound database or it can share the identification key as is the case here. The reaction object contains information about the reaction and its properties including thermodynamics, but also categorization of the reaction type. The catalyst object contains catalyst properties and finally the conditions object stores the conditions under which the system is

being studied, including the temperature and pressure limits, the phase behavior at reaction conditions and so on. The properties for the objects have been organized in a hierarchy where the degree of detail increases as one moves to the lower levels of the hierarchy. Each of the fundamental objects also has link tables, which are a mapping between the objects. For example, a catalyst is a mixture of compounds located in the compound object, and the reaction object has a stoichiometric entry which describes the transformation of compounds.

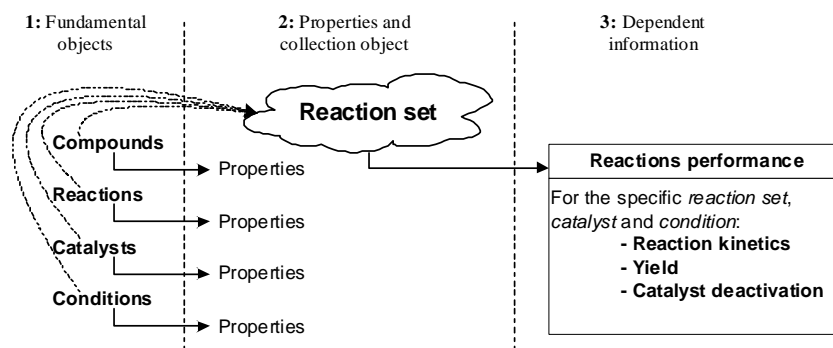

Figure 3.3: Reaction database structure.

A reaction system is a logical collection of the fundamental objects. Therefore, a "Reaction set" object is introduced which acts as an aggregator of all the information in the fundamental objects, thereby grouping all information relevant to the reactions for the system studied. Furthermore, the catalyst and condition together with the reaction set defines a common identification key which groups data like kinetics, yield and catalyst deactivation, for the specific criteria where this information is valid. This approach makes it possible to store simultaneously the yield and kinetics information for different conditions and catalysts, without having to duplicate all reaction data which are in common.

The tables for the kinetic parameters in the database are general arrays and are designed to provide flexibility for any variety of kinetic expressions, either empirical or derived from fundamental molecular or micro-kinetic considerations. A software application that uses the database simply maps the array into its custom kinetic framework. The reaction analysis tool developed here for kinetic estimation for example, allows for both simple mass action expression as well as a generalized Langmuir-Hinshelwood-Hougen-Watson (LHHW) expression. For the specific rate only the Arrhenius equation has been used (rate and specific rate expressions are found in standard text books on chemical reaction kinetics, e.g. Laidler (1987)), but again the database structure is not limited to this equation.

3.3.1.2 Analysis toolkit

In addition to the knowledge in the database, the reaction analysis tool has modules for:

- Estimation of reaction kinetics
- Reactor simulation
- Reactor optimization

In using these modules, additional information is required, for example: reactor data and experimental data (see figure 3.2). Therefore data relevant to the specific project is stored in a project file. Also data for the current reaction set from the database being used for the project is stored in the project files, thereby making the project files independent of the database and easy to share among coworkers. A typical situation initiating use of the tool can be described as follows:

A chemist has found a candidate reaction route to a target compound. On starting the experimentation, he/she discovers several undesired events such as catalyst deactivation, parallel or successive byproducts. In order to proceed now with the experimental plan, the chemist must reconcile his/her observations with his/her hypothesis of the reaction mechanism.

The kinetic estimation module provides the logical computational framework to easily represent and solve this problem. Here, given the current experimental data, one can quickly and conveniently reason with several reaction hypotheses. The most likely reaction mechanism and kinetics is then used to develop the next experimental plan. The next experiment can be designed at the point of maximum productivity (conditions at which the model predicts the best yield, found by the optimization module) or at points for model discrimination. The cycle of experimentation and model-based reasoning continues until the chemist is satisfied that the observations support the chemical reaction hypothesis. At this point the model is considered to be validated and ready to be used in reactor or flowsheet synthesis problems.

Regardless, of what module in the reaction analysis tool is currently used, the central equations remains the same, instead it is the identity of the unknowns which are different for the problem solved. For example for a batch reactor the central equations are:

Mass balance for compound j:

$$\frac{dC_j}{dt} = R_j^{net} \cdot V \quad (3.8)$$

where,

$$R_j^{net} = \sum_{i=1}^{NC} r_i \cdot SC_{j,i} - \sum_{i=1}^{NC} r_i^{rev} \cdot SC_{j,i} \quad (3.9)$$

$$r_i = k_i \prod_{j=1}^{NC} C_j^{\alpha_{i,j}} \quad (3.10)$$

$$k_i = A e^{(-E/RT)} \quad (3.11)$$

In the above equations, equation 3.9 represents the reaction rate term, equation 3.10 the rate expression in terms of standard mass action kinetics, equation 3.11 the Arrhenius equation for the specific rate and $\alpha_{i,j}$ is the reaction order of compound j in reaction i .

When solving the estimation problem the unknowns are the kinetic parameters – the pre-exponential factor (A), the activation energy (E) and the reaction order (α). Known from experiments are the measured concentration at time t and reactor sizing variables, the stoichiometric coefficients are known from the database. Once the estimation problem is solved and kinetic parameters are obtained it is possible to solve the simulation and optimization problems. For the simulation problem the unknown would be the concentration with time for batch reactors. For the reactor optimization problem the unknown can be one or more among: reactor sizing, starting concentration, feed rate and concentration and/or total time, also depending on the reactor type.

In the method of solution currently used in the tool, for batch and plug flow reactors the differential equations system is converted to an algebraic equations system by orthogonal collocation on finite elements. For the estimation and optimization cases, the resulting mathematical problem is a nonlinear optimization problem, whereas in the simulation case, the differential equations system or the converted algebraic equations system may be solved.

The above description gives an overview of the type of problems and how these are solved with the reaction analysis tool. Extra features have been put into the tool, which makes it possible to handle special or more complex problems. General options are:

- Choice of rate expression (mass action or LHHW expression).
- Choice among standard type reactors with the option for modelling of 2 phases (equilibrium is calculated from specified distribution coefficients). Furthermore, the batch reactor can be simulated in fed-batch mode.
- Definition of product-reactant pairs in order to calculate yields.

Options and features for the estimation module are:

- Due to the uncertainty at this stage (the reaction mechanism is unknown), significant modeling flexibility is provided to the user in terms of

providing guesses on the reaction mechanism, kinetic expressions, quasi-equilibrium reactions etc.

- Bounds on the kinetic parameters and reaction orders along with any special weighting options.
- Kinetic parameters can be marked as validated already and therefore left out when solving the estimation problem.
- The optimal estimates and several diagnostic graphs are presented to the user to test the validity of the mechanism, given the experimental observations.

The simulation component allows the user to perform what-if scenarios and to design the next experiment, given the current reaction mechanism and kinetics. Here, the user provides the reaction conditions and the simulation component presents the reactor profiles and conversions to the user. The optimization component allows for the graphical formulation of reactor optimization scenarios. Here, the user is provided with rich options for dynamic optimization. For example, in batch systems, the user can request the best fed batch addition and temperature profiles while imposing state constraints.

3.3.2 Separation synthesis

The algorithm presented in Jaksland *et al.* (1995) is used as a basis for the steps in the integrated framework considering separation synthesis aspects. This algorithm is based on thermodynamic insights, where the knowledge of which type of differences in properties are exploited as the driving force in each type of separation techniques. The algorithm consists of two levels, each of them divided into 6 subalgorithms.

The first level calculates differences in pure component properties for each binary pair that can be combined from the compounds in the mixture (called binary property ratios). For each of the pairs the algorithm identifies the largest property ratio, thereby the most feasible separation technique for the pair is identified. After a screening step, the largest ratio (which remains) after screening is identified, this indicates the first separation task to be performed and the corresponding separation technique for the flowsheet.

In the second level both pure compound and mixture properties are considered in order to simultaneously sequence and select the separation tasks and techniques. By including mixture properties the second level is able to consider, more easily, separation techniques requiring MSA's (Mass Separating Agents) and to give improved estimates for condition of operation. At the end of the second level a physically feasible separation flowsheet is produced together with feasible alternatives for each separation task. This feature is especially useful in combination with structural optimization techniques.

In this PhD-project, the above algorithm was further developed to include two important aspects – inclusion of reactions and identification of possible

recycle streams. This was needed in order for the algorithm to handle complete process flowsheets, which is considered in this thesis. The following features were added:

- An extra label is added with each compound. The label identifies the function of the compound in the flowsheet or part of the flowsheet considered (i.e. reactant, product, inert or solvent).
- Reactions and reactors are added to the algorithm, along with a mapping of which compounds are entering as reactants in which reactors.
- Each time the algorithm places a separation technique at least two new (product) streams are introduced in the flowsheet. These streams are scanned for reactants that could be recycled to a reactor in the flowsheet. If reactants are identified it is suggested to recycle the stream. If the stream contains other compounds than reactants (for example, inert compounds, solvents, etc.) it is suggested to add a purge, in order to avoid build up – or accumulation.

3.3.3 Process design tool (separation processes)

In order to arrive from the stage of having an initial flowsheet with feasible alternatives to a stage where optimization techniques can be applied to search for the optimal flowsheet, equipment design parameters and initial values for the operating conditions (for each equipment) need to be determined. A tool in the integrated framework for process synthesis that can be used for obtaining some of the necessary information has been developed as part of this thesis. The main features of this tool are:

- For non-reactive systems:
 - Calculation of ternary diagrams with residue curves and heterogeneous liquid boiling surface.
 - Distillation column design by the driving force based approach, developed by Gani and Bek-Pedersen (2000).
 - Distillation column design by the equilibrium based approach, developed in this thesis, see section 3.3.3.1.
- For reactive systems:
 - Reactive bubble-point calculation.
 - Reactive binary and ternary phase diagrams.
 - Reactive residue curve maps.
 - Reactive distillation column design by the equilibrium based approach.

The reactive system algorithms were developed by Pérez-Cisneros (1997) see also Pérez-Cisneros *et al.* (1997) and Pérez-Cisneros and Daza (2000).

3.3.3.1 Equilibrium based algorithm

An algorithm for the determination of distillation column design variables has been developed. The following variables can be obtained from the algorithm:

- The number of equilibrium stages (trays)
- Feed tray location
- Reflux ratio (requires an extra iteration loop)
- Estimates of temperature, liquid and vapor composition on each tray
- Estimates of liquid and vapor flowrates throughout the column.

The following specifications are required to use the algorithm:

- Single feed to the column: Total flowrate F , composition \overline{z}_F , temperature T_f and pressure P_f .
- Two desired products: Compositions in the top \overline{y}_D and the bottom \overline{x}_B .
- If the mixture contains four compounds or more, identification of the light and heavy key compounds are required.
- Estimate on reflux ratio (R).

The following assumptions were made for the algorithm:

- Zero pressure drop throughout the column.
- Ideal plates.
- Vapor and Liquid flowrates only change at feed plate(s), that is, constant molal overflow.
- Effects from possible sub cooled or superheated feed(s) are neglected.

Before the algorithm is presented (as a graphical flowchart), the sub steps are first described. These steps are primarily equations to be solved as part of the algorithm, either once or repeatedly within a loop. Note that in the following, plates in top and bottom sections are counted with different conventions, the condenser is assigned plate number 1 ($M=1$) and plates below have increasing numbers, the reboiler is also assigned plate number 1 ($N=1$) and plates above have increasing numbers. This is because calculations start at the two ends and proceed towards the feed plate. Furthermore the terms DewT and BubbleT calculations refer to the dew and bubble point calculations for temperatures at given pressures (Smith and Van Ness, 1987).

Substep 1: Overall column mass balance

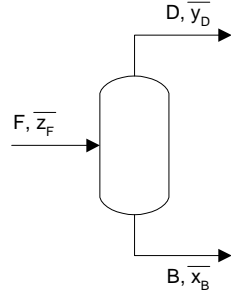

$$B = F - D \quad (3.12)$$

$$Fz_{F,1} = Dy_{D,1} + Bx_{B,1}$$

$$\Downarrow$$

$$D = F \cdot \frac{(z_{F,1} - x_{B,1})}{(y_{D,1} - x_{B,1})} \quad (3.13)$$

Substep 2: Calculation of column flowrates

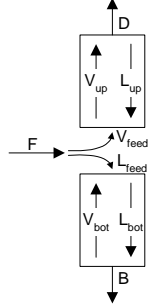

$$L_{up} = L_0 = R \cdot D \quad (3.14)$$

$$L_{bot} = L_{up} + L_{feed} \quad (3.15)$$

$$V_{bot} = L_{bot} - B \quad (3.16)$$

$$V_{up} = V_{bot} + V_{feed} \quad (3.17)$$

Substep 3: Top section

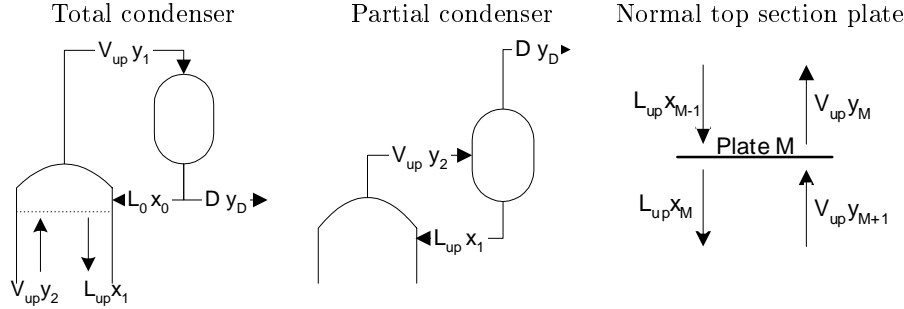

A common characteristic for condensers (independent of type) and a plate M in the top (rectifying) section is that the net number of moles on a compound basis which is going to the plates above or leaving as a distillate, is given by $\overline{y_D}D$. Thus, the composition of the liquid leaving the plate and the vapor entering from the plate below, can be calculated by:

a. Perform a DewT calculation at P , $\overline{y_M}$ obtain $\overline{x_M}$ and T_M .

b. Mass balance on plate M to calculate $y_{M+1,i}$:

$$y_{M+1,i} = \frac{y_{D,i}D + x_{M,i}L_{up}}{V_{up}} \quad (3.18)$$

Note: $M = 1$ for the condenser and for total condensers: $\overline{x_0} = \overline{y_1} = \overline{y_D}$

Substep 4: Bottom section

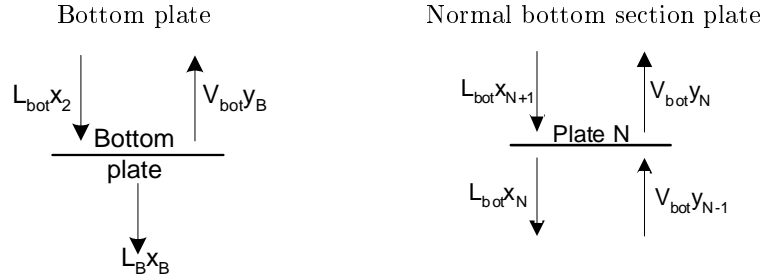

A common characteristic for reboilers and a plate N in the bottom (stripping) section is that the net number of moles on a compound basis which is going to the plates below or leaving as a bottoms product, is given by $\overline{x_B}B$. Thus, the composition of the vapor leaving the plate and the liquid entering from the plate above, can be calculated by:

- Perform a BubbleT calculation at P , $\overline{x_N}$ obtain $\overline{y_N}$ and T_N .
- Mass balance on plate N to calculate $x_{N+1,i}$:

$$x_{N+1,i} = \frac{x_{B,i}B + y_{N,i}V_{bot}}{L_{bot}} \quad (3.19)$$

Note: $N = 1$ for the reboiler.

Substep 5: Heavy key identification

For binary mixtures and mixtures with more than three compounds the identity of the light and heavy key compound is needed for the stop criteria for the algorithm. For binary mixtures the identity of the heavy key (IDHK) can easily be determined from the product specifications:

$$\begin{aligned} &\text{If } x_{B,1} > x_{D,1} \text{ Then} \\ &\quad IDHK = 1 \\ &\text{Else} \\ &\quad IDHK = 2 \end{aligned}$$

For mixtures with more than three compounds the identity of the heavy key compound is a specification to the algorithm.

Substep 6: Stop criteria

The stop criteria used, is dependent on the number of compounds in the mixture to be separated.

Binary mixtures and mixtures with more than 3 compounds:

For binary mixtures and mixtures with 4 or more compounds the criteria is based on conditions for the light and heavy key compounds. Setting up a mass balance for the feed plate FP yields:

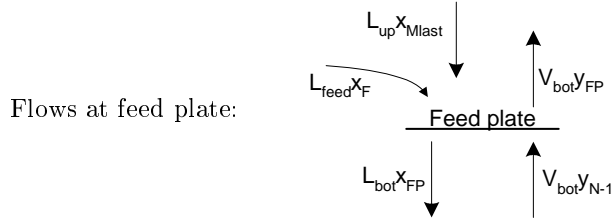

$$x_{B,i}B + y_{N_{FP},i}V_{bot} = x_{M_{last},i}L_{up} + x_{F,i}L_{feed} \quad (3.20)$$

Where $x_{M_{last},i}$ is the mole fraction of compound i on the last plate (the plate just above the feed plate) in the top section. While the net flowrate of heavy key compound downwards for the column section remains constant (for example, $x_{B,IDHK}B$ for the bottom section) this is not the case for the liquid flow of heavy key. The liquid flow of heavy key will typically increase from plate to plate downwards, around the feed plate the following inequalities are valid:

$$l_{M_{last},IDHK} + l_{feed,IDHK} \leq l_{N_{FP},IDHK} \leq l_{N_{FP-1},IDHK} \quad (3.21)$$

where:

$$l_{N_{FP},IDHK} = x_{N_{FP},IDHK}L_{bot} = x_{B,i}B + y_{N_{FP},i}V_{bot}$$

Substituting 3.21 into 3.20 yields the following inequality for plates below the feed plate:

$$x_{B,IDHK} \geq \frac{x_{M_{last},IDHK}L_{up} + x_{F,IDHK}L_{feed} - y_{N,i}V_{bot}}{B} \quad (3.22)$$

A good stop criterion (identification of the feed plate location) for the algorithm is when 3.22 no longer holds. The algorithm consists of one part calculating the top section plates and of one part calculating the bottom section plates. Depending on whether a top or bottom plate were calculated most recently the inequality criterion (equation 3.22) should be checked against all of the plates in the other section.

Mixtures with 3 compounds:

If the calculated plate compositions are plotted in a triangular diagram, a curve connecting liquid compositions in the top section and corresponding curve for the bottom section will intersect each other if the reflux ratio is sufficient. This is illustrated in figure 3.4 for a system of n-Butane, n-Pentane and n-Octane. The intersection property is used as identification of the feed plate for mixtures

with 3 compounds. The intersection can also be determined algebraically by setting up the expressions for linear lines for both top and bottom, based on two adjacent plate composition points, and then checking if the two lines intersect within the valid composition range. Again, depending on whether a top or bottom plate were calculated most recently this should be checked against all of the plates in the other section.

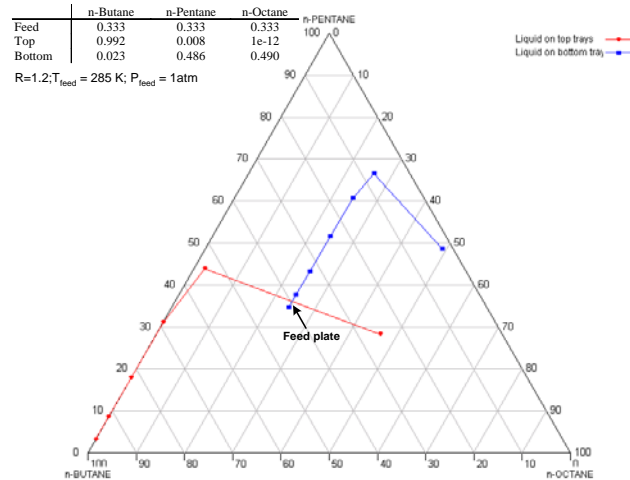

Figure 3.4: Triangular diagram of liquid compositions for n-Butane, n-Pentane and n-Octane. Feed plate location is identified at the intersection of the two curves.

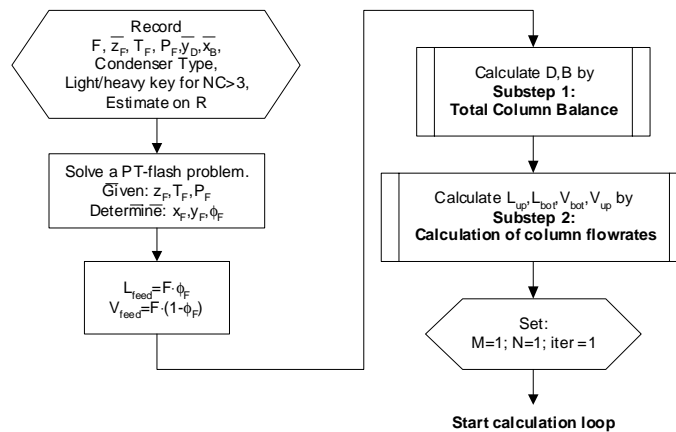

Figure 3.5: Preparation steps for the equilibrium based column design algorithm.

Algorithm flowchart

In the following the algorithm is presented for a fixed reflux ratio. If the reflux ratio is to be determined also, an extra iteration loop is required. The algorithm is shown as a flowchart in figures 3.5 (preparation steps) and 3.6 (calculation loops). As can be seen the calculation loop (3.6) will continue until 100 top and bottom stages are calculated or the stop criterion is fulfilled. If the former situation occurs, then in this case it is recommended to increase the reflux as a "pinch" condition is encountered. If the loop terminates through the stop criterion instead, the bottom stages are renumbered and a common feed plate composition is calculated.

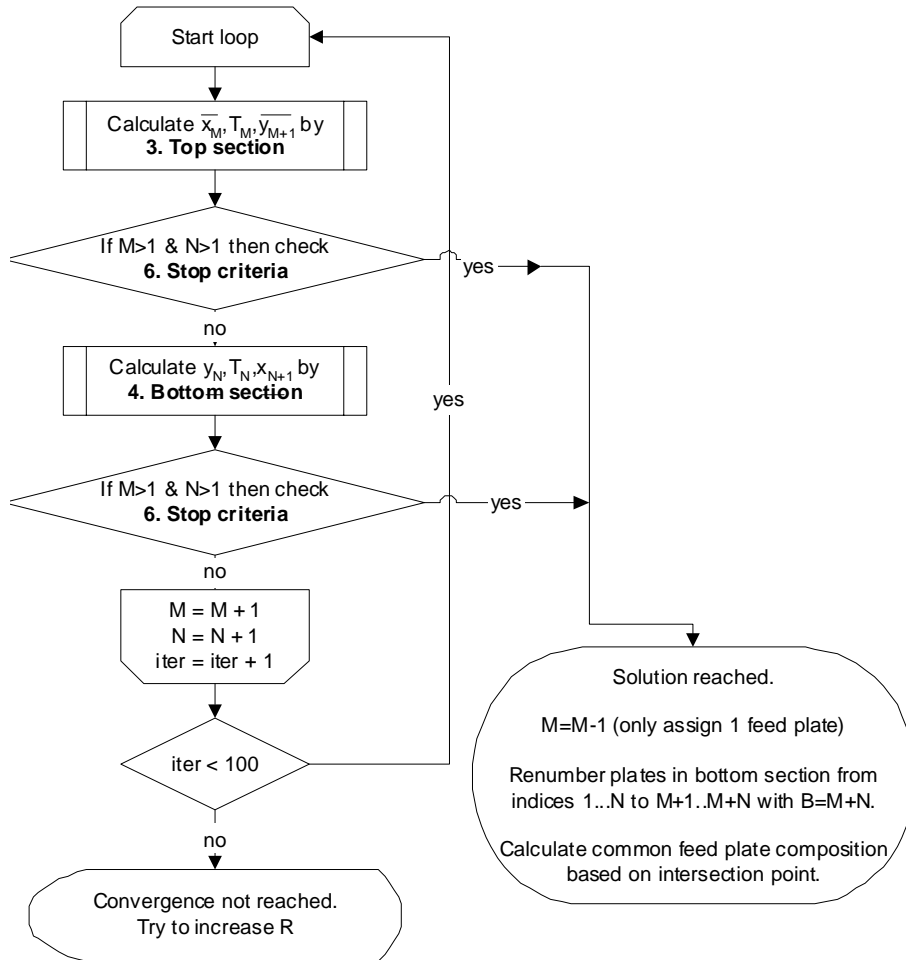

Figure 3.6: Calculation loop for the equilibrium based column design algorithm.

3.3.4 Other methods/tools in the integrated framework

In the previous sections tools and algorithms that can be used when generating flowsheets and superstructures for process synthesis problems have been described. However if these tools are used on a "stand alone" basis, a significant amount of work is required in order to collect and organize the information so that an optimization problem can be formulated, which is necessary if the preliminary process design task should be completed by obtaining the optimal design. The idea behind the integrated process synthesis framework is the following – by providing the proper framework for incorporating tools, a lot of the more tedious tasks of collecting and organizing information for the optimization problem formulation can be eliminated. The integration framework used in this thesis is the Integrated Computer Aided System (ICAS) developed at CAPEC (figure 3.7 illustrates how ICAS acts as the central driver in the integrated process synthesis framework). In addition to providing the proper framework for collecting and storing, other components which are available in ICAS can also be used when solving synthesis problems:

- CAPEC compound database, this is a compound (property) database used by all tools implemented in ICAS.
- Utility calculations. A number of phase equilibria calculations that can be helpful for evaluating/analyzing operating conditions.
- Modeling environment. New unit operation models can developed, which can later be used in process simulation and optimization.
- Computer Aided Molecular Design tool.

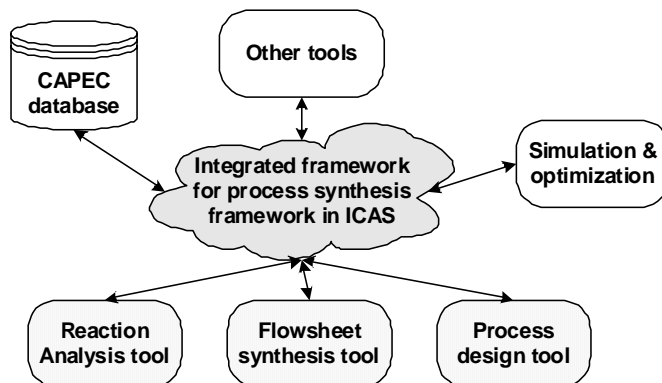

Figure 3.7: Role of ICAS in the integrated framework for process synthesis

3.3.5 Structural optimization tool

Once a flowsheet superstructure with equipment design parameters has been obtained with the integrated framework, the optimal solution can be obtained by applying structural optimization techniques. Structural optimization techniques have not been developed as part of this thesis, however, two different algorithms have been applied for the solution of case studies in this thesis. The first approach has been developed by Kravanja and Grossmann (1994), while the second, called "Interactive MINLP solver", which is the main algorithm used in this thesis, was developed by Henriksen *et al.* (2000).

The main advantage of this interactive algorithm is that it has been implemented in the Integrated Computer Aided System (ICAS) where also the rest of the framework developed in this thesis have been incorporated. This way the "Interactive MINLP solver" can act as part of the integrated framework. The algorithm is based on the decomposition approach, where a NLP subproblem (the primal problem) is solved in the inner loop and a MILP master problem is solved in the outer loop. The solver can operate in two modes:

- a) Equation system mode – here all equations are given explicitly. This is the typical way of using MINLP solvers.
- b) Simulation mode – in this operating mode, process model equations are solved by a process simulator. This way the process model equations does not need to be supplied explicitly by the user.

When the algorithm is used in simulation mode, the NLP subproblem is handled by the simulation engine with SQP optimizer (called ICASSim), which is already available in ICAS. The principle behind the simulation mode in the "Interactive MINLP solver" algorithm is illustrated in figure 3.8. The opti-

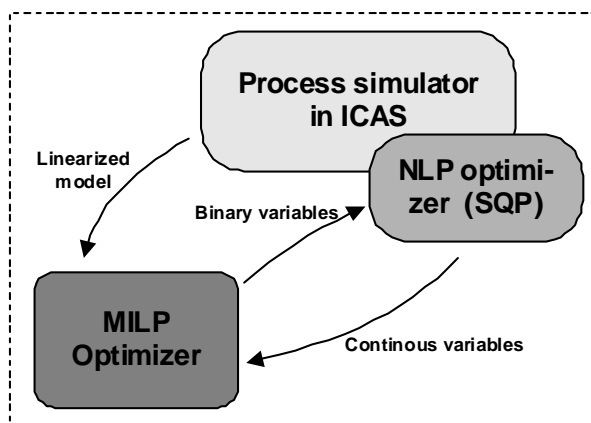

Figure 3.8: Information flow in the interactive MINLP algorithm

mization problem to be solved is given by equations 3.1-3.5, however for the interactive MINLP solver in simulation mode the problem is rewritten:

$$\begin{aligned} & \min_{d,y} f(d, x, y) \\ \text{s.t.} & \\ & P(d, x, y) = 0 \\ & h(d, x, y) = 0 \\ & g(d, x, y) \leq 0 \\ & d \in D \subseteq R^n; \quad x \in X \subseteq R^m; \quad y \in Y = \{0, 1\}^q \end{aligned}$$

Here $P(d, x, y)$ is representing the process model equations corresponding to $h_2(\mathbf{x})$ in equation 3.3, the vector of continuous variables \mathbf{x} has been divided into continuous problem design variables (d) and process state variables (x). The solution strategy to the MINLP problem is based on the Outer Approximation algorithm (Duran and Grossmann, 1986a), where the MILP master problem is obtained by linearization at the optimal point from the NLP sub problem. The primal and master problem to be solved in simulation mode is then given by Henriksen *et al.* (2000):

NLP sub problem	MILP master problem
$\begin{aligned} & \min_d f(d, x, y^k) \\ \text{s.t.} & \\ & P(d, x, y^k) = 0 \\ & h(d, x, y^k) = 0 \\ & g(d, x, y^k) \leq 0 \\ & d \in D \subseteq R^n; \\ & x \in X \subseteq R^m \end{aligned}$	$\begin{aligned} & \min_{d,y,\mu_{lin}} \mu_{lin} \\ \text{s.t.} & \\ & \mu_{lin} \geq f(d^k, x^k, y^k) + \nabla_{d,y} f(d^k, x^k, y^k) \begin{pmatrix} d - d^k \\ y - y^k \end{pmatrix} \\ & 0 = h(d^k, x^k, y^k) + \nabla_{d,y} h(d^k, x^k, y^k) \begin{pmatrix} d - d^k \\ y - y^k \end{pmatrix} \\ & 0 \geq g(d^k, x^k, y^k) + \nabla_{d,y} g(d^k, x^k, y^k) \begin{pmatrix} d - d^k \\ y - y^k \end{pmatrix} \\ & \sum_{i \in B^k} y_i^k - \sum_{i \in NB^k} y_i^k \leq B^k - 1 \\ & d \in D \subseteq R^n; \quad x \in X \subseteq R^m; \quad y \in Y = \{0, 1\}^q \end{aligned}$

The authors also gives a 7 step algorithm where the solution to the primal problem provides the upper bound and the master problem provides the lower

bound. Furthermore they show how the linear model for the master problem can be generated by making perturbations in the continuous design variables and through feasible step changes in the binary variables. The main advantage of solving in the simulation mode is that the process model does not have to be given explicitly. Therefore, problems where rigorous thermodynamic models needs to be used, can be tackled – this would be difficult if the model equations were to be supplied explicitly and could also create large problems.

An alternative 'simulation mode' algorithm can be applied for the special case when the number of flowsheet alternatives (or the number of binary variables) is not too large. The MILP master problem solution is simplified as follows. First a list of feasible sets of binary variables is generated by considering only the constraints involving binary variables. Then the inner-loop NLP sub-problem is formulated and solved starting with a feasible set of binary variables. At the optimal NLP sub-problem solution, all the remaining feasible sets of binary variables are evaluated (does not require solution of NLP sub-problem). The feasible set that satisfies all constraints and has the best objective function value is chosen as the next feasible set of binary variables for the NLP sub-problem. At the optimal solution of the NLP sub-problem, only the remaining feasible set of binary variables is considered. In this way, with each outer-loop iteration, the number of alternatives that need to be considered decreases and the optimal flowsheet is determined when the objective function cannot be further improved. It is not claimed that this solution approach is the most efficient. The proposed solution strategy, however, provides an alternative with useful features such as interactive solution of the MINLP problem, solution of the NLP sub-problem with rigorous simulation models and embedding the solvent design problem within the separation process synthesis problem.

INTEGRATED PROCESS SYNTHESIS FRAMEWORK

4.1 Introduction

This chapter describes the integrated process synthesis framework and how the individual components (described in the previous chapter) of the framework can work together so that preliminary design tasks, as formulated in section 3.2, can be solved. Parts of the framework work together in a form that can be labelled a hybrid synthesis method. The main feature of the hybrid method is that it combines different synthesis algorithms so that methods based on a mathematical solution approach can be applied, but before this, the hybrid method generates an appropriate problem formulation by the use of, for example, a synthesis algorithm based on thermodynamic insights. Thereby, the hybrid method is able to reduce (if feasible) the size of the mathematical problem, before it is solved. The solution procedure in the integrated framework has three main phases:

- Pre-analysis
- Flowsheet and superstructure generation
- Simulation and optimization

The hybrid synthesis method is an interactive method where it is possible to go forward and backward between phases, as well as between steps of a phase. The procedure of solving a synthesis problem with the framework could proceed from one phase to the next in order to obtain the final solution. However, usually some previous phases or steps would need to be revisited. For example, it could be that more separation alternatives needs to be generated by relaxing a constraint and then to go forward again in order to determine a new solution. A diagram of the components in the different phases of the framework is shown in figure 4.1. The method is valid for new processes as well as retrofit problems for existing processes. The known or specified information

is different for the two cases but the problem formulation is similar. For example, in a new process, a typical problem formulation starts with information of raw materials (or feed streams), desired products (quantities) and reaction details. In the case of retrofit problems, a typical problem formulation starts with a known process flowsheet or list of equipments and a set of new objectives for the process. In both situations, the goal for the pre-analysis phase is to obtain a problem formulation and knowledge, so that in the superstructure generation phase, a superstructure (which incorporates almost all feasible alternatives) and a feasible flowsheet that serves as a good initial estimate for the structural optimization phase, can be obtained. The goal of the structural optimization phase is to determine the optimal flowsheet through the solution of an appropriate (MINLP) model. Furthermore, an evaluation of the solution must be carried out, in order to verify if the solution is realistic (use of common sense) as well as to account for aspects that could not be taken into account in the optimization problem. The sections 4.2, 4.3 and 4.4 provides a detailed description of the different phases in the framework.

4.2 Pre-analysis

The following section describes the pre-analysis phase, which must be carried out before the algorithm for superstructure generation is employed. The pre-analysis involves the following steps:

- Identification of problem type and knowledge about the process.
- Collection of compound properties, and determination of a thermodynamic model which is valid for the compound mixture considered in the problem.
- Determination of mechanism and kinetics of the reactions involved in the process, and possible alternatives for carrying out the reactions.
- Information search for the possible use of external media based separations.

4.2.1 Problem type and formulation

Synthesis problems arise when either, the synthesis and design of new a process is required (grassroot situation), or an existing process needs modification (the retrofit situation). The causes for both situations can be many, an example of a problem formulation for the grassroot situation could be:

”A pharmaceutical company has bought the rights to a new revolutionary drug, discovered by a chemist at an university. The drug has undergone numerous evaluation and test phases, and now a process capable of producing 150 kg per year needs to be designed.”

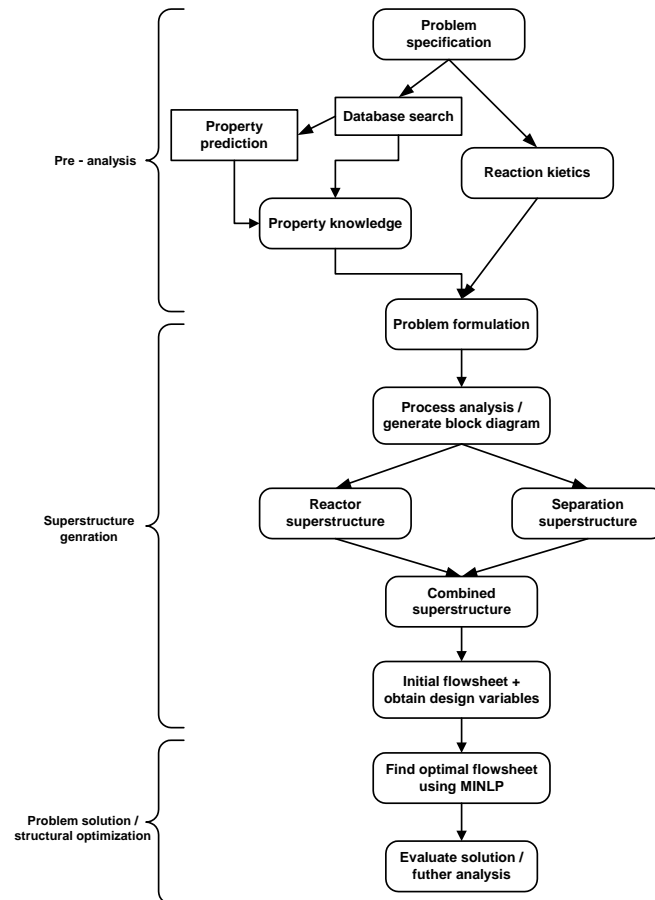

Figure 4.1: The main components in the phases

Causes for the retrofit situation can, among many others, be: New production objectives, i.e. the company's business unit has discovered an increasing demand for a product, or another type of product is to be produced in the plant, it could also arise from external regulations, for example the problem formulation could be:

”Due to new environmental regulations, an existing process is in conflict with the new regulations. Determine the necessary modifications to the process, in order to comply with the new regulations.”

Synthesis problems from both categories can be solved with the algorithm presented in the following sections, even though the progress may differ a little. However, common to both type of problems is the importance of collection and utilization of knowledge about the process, both from literature and inside the company. Among the relevant information revealed by a literature search can be:

- Design details of existing plants
- Special solutions currently used in plants producing similar products
- Reaction mechanism and information about the kinetics of the reaction.

Company knowledge can reveal a lot of valuable information for generation and solution phases. Among such information would be:

- Properties of the chemical species involved (i.e. product stability)
- Limitation in types of equipment to be utilized in the solution
- Models for special equipment of potential interest
- In the retrofit case models for the existing plant might also be available

For both sources of knowledge it is true that complete lists of relevant knowledge cannot be enumerated. It will be dependent on factors such as type of industry, common company practice (and how well knowledge of this category is organized), internal and external (human)resources available in the company.

4.2.2 Collection of property knowledge

Information about compound properties (pure as well as mixture) must be collected in the pre-analysis phase, since they are needed in a number of steps after the pre-analysis phase. In the superstructure generation algorithm presented in section 4.3 the most important uses of compound properties are:

- In order to generate a list of feasible separation alternatives, compound properties are needed:

- A number of different pure compound properties (Table 4.1) are used to screen out infeasible separation techniques from a master list of separation techniques.
- Binary component mixture calculations (VLE, SLE, LLE) are needed in order to identify binary compound pairs with azeotropic behavior, eutectic points or miscibility gaps. Valid thermodynamic mixture property models are needed to calculate this type of behavior.
- Multi component mixture property calculations are needed for evaluation and screening of solvent alternatives, again valid thermodynamic mixture models are needed.

Section 2.4.1 provides a detailed overview on the sources of compound properties (which can be databases or property prediction methods). Also in this section, recommendations on which tools can be used to find valid thermodynamic models are given.

- If techniques applying reactive separation principles are to be considered, it is important to have information about the phase behaviour of the reactive system in order to validate the feasibility of techniques. The design tool described in section 3.3.3 can be used to generate reactive phase diagrams for reactive systems.
- When equipment design is determined, there is also an intensive use of thermodynamic mixture property calculations.

Information about which thermodynamic models can be used for the specific system in question is also needed when the generated flowsheet is validated through simulation and in the structural optimization phase. Furthermore, before the superstructure generation phase it is important to enumerate which

Properties	
Molecular Weight	Acentric Factor
Critical Temperature	Critical Pressure
Critical Compressibility Factor	Critical Volume
Normal Boiling Point	Dipole moment
Radius of Gyration	Melting Point
Triple Point Temperature	Triple Point Pressure
Molar Volume	IG Heat of Formation
IG Gibbs of Formation	IG Absolute Entropy
Heat of Fusion at T _{melt}	Stand Net Heat of Combustion
Solubility parameter	Van der Waals Volume
Van der Waals Area	Normal Vapor Pressure

Table 4.1: List of pure component properties required for screening of feasible separation techniques

properties are not available (from the database or from prediction methods). Also the quality of data for the properties available should, if possible, be considered so that this can be taken into account when identifying the feasible separation techniques.

Finally other properties will also be of importance to the specific synthesis problem, for example, product stability that must be accounted for in the design. If the process involves complex chemicals (for example pharmaceuticals) properties such as stability may not be available from public databases or from reliable prediction methods. Instead, they may be available 'in-house' or need to be determined 'in house'.

4.2.3 Reaction knowledge

Usually process synthesis problems includes one or more chemical reactions that needs to be considered. In order to do this, knowledge about the reaction mechanism, stoichiometrics and kinetics must be collected or generated, before the synthesis problem is solved. Section 3.3.1 describes a tool, developed as part of this thesis, for generating such knowledge. It is important to note that experimental reaction data is needed in order to derive reaction kinetics, either data from the literature or from experiments. Alternatively, reaction kinetics may be found in literature directly or it could be available from databases.

In addition to deriving the reaction kinetics, the analysis toolkit described in 3.3.1.2 also has the capability (once the kinetics has been determined) of determining the optimal reactor design / operational configuration in terms of reactor volume, temperature profiles and others. This optimization, however, is carried out without considering the rest of the flowsheet. Furthermore, only simple reactor models can be considered currently. Other methods for reactor synthesis has been described in literature (see section 2.3.1). It is however possible to consider more complex reactor models, in the optimization phase, by introducing such models through the modeling tool available in the integrated system (see section 3.3.4).

4.2.4 Information on external media based separations

In the separations screening step which is part of the superstructure generation phase, feasible external media based separation techniques (for example separation using membranes) may be identified, based on differences in pure compound properties. However, even though identified as feasible, their possible use will depend on the availability of a suitable external medium. The search for such a suitable external media can be carried out either during the pre-analysis phase or when a potential separation technique is identified. Regardless of strategy the sources for identification of external media are the same and can be listed as follows:

- Knowledge base

- Literature search – The constantly improving search engines for scientific publications makes this an important source
- In house knowledge
- Request at external media manufacturer – A number of companies has specialized in providing solutions using external media

4.3 Flowsheet and superstructure generation

As part of this thesis a systematic method for generating flowsheet alternatives and, based on these, generation of superstructures has been developed. The methodology employs a multi step algorithm where the type of knowledge gathered in the pre-analysis phase serves as input. The multi step algorithm comprises the two algorithms presented in Hostrup *et al.* (1999) and Hostrup *et al.* (2001). An extension to these is that the equipment design features has been developed further, for example, to include algorithm for equilibrium based distillation design.

The work flow through the flowsheet and superstructure generation method is as follows. First the available information about the process is analyzed in order to identify the phenomena involved in terms of reactions and separations. This forms the basis for a division into reaction and separation blocks, and for each block process alternatives are generated. The separation alternatives are generated through an analysis of the physico-chemical properties of the mixture present in the system. This approach is an extension of the method by Jaksland *et al.* (1995), the primary extensions are handling of reactors and recycles in the flowsheet, superstructure generation and improved mixture properties based analysis. When all blocks have been analyzed with screening of alternatives, the blocks are recombined and the potential recycles are connected. This will form the flowsheet superstructure together with an initial (feasible) flowsheet.

4.3.1 Algorithm for generation of initial flowsheets and superstructure

In this subsection the steps for the flowsheet and superstructure generation algorithm are first given with a short description, then where needed, further details are provided.

Step 1 Identities of all components present in the system must be known together with desired products and raw materials. Analyze the information known about the process. Determine the starting point for the problem solution in terms of problem formulation and a list (Ω) of separation techniques to be considered. If, based on the information available, a superstructure is already available go to step 8. Otherwise, go to step 2. Further details for this step can be found in section 4.3.1.1.

Step 2 Identify the reactions in the process and use this information to produce a block diagram consisting of $|R|$ reaction and $|S|$ separation blocks. This should only be done for the part of the process that needs a new design. See section 4.3.1.2 for more details to this step.

Step 3 For each reaction block r ($r \in R$) identify the possible reactor configurations. Here, the reaction knowledge from section 4.2.3 is needed, however at its current state the algorithm does not feature specific methods for identifying reactor configurations. Methods for this are available in literature (see section 2.3.1), often promising configurations can also be identified during the determination of reaction kinetics. If more than one reactor configuration is identified as promising, logical splitters (see section 2.2.1) are used to generate a superstructure of reactor configurations for the specific reaction block r . Each reaction block r is now represented by a superstructure fragment.

Step 4 Enumerate, for each separation block s ($s \in S$), the set of relevant separation tasks T_s by considering which compounds are present in block s and if these compounds need to be separated from each other (see section 4.3.1.3 for clarification). A list of feasible separation techniques ($\Omega_{s,t}$) for each relevant separation task t ($t \in T_s$) is generated by the following sub steps:

- 4.A. Start with the master list Ω of separation techniques and copy all items to the local list $\Omega_{s,t}$. Based on the property analysis made during the pre-analysis phase, screen out separation techniques from $\Omega_{s,t}$, if: The property data related to a separation technique, is not available for one of the two compounds in t .
- 4.B. Perform a pure component properties based analysis (Algorithm 1.1-1.4 in Jaksland (1996), see also appendix B) and eliminate separation techniques that are not feasible from $\Omega_{s,t}$.
- 4.C. For each separation technique from the list $\Omega_{s,t}$ that is based on the utilization of external media (for example membranes): Determine if information about a suitable external media (see section 4.2.4). If no information can be found eliminate the separation technique from the list $\Omega_{s,t}$.
- 4.D. Perform a binary mixture properties based analysis (search for azeotropes etc.). Based on the analysis, eliminate the infeasible separation techniques from the list $\Omega_{s,t}$. The potential infeasible separation techniques are the techniques from Table 4.2 that are primarily based on property difference. For example, if an azeotrope was identified for the compounds in task t normal distillation can be eliminated from $\Omega_{s,t}$.
- 4.E. Identify from the list $\Omega_{s,t}$ (see Table 4.2) the separation techniques requiring mass separating agents (solvents). Generate solvent alternatives for these techniques using CAMD (Harper, 2000) or CAMS

(Cabezas *et al.*, 1996). If none are found, eliminate separation techniques based on the use of solvents from the list $\Omega_{s,t}$ of separation techniques.

4.F. Perform (by utilizing the process design tool, section 3.3.3) multi component mixture properties based analysis for the generated solvent alternatives (phase behavior, location of ternary azeotropes, separation boundaries, etc.). Based on the analysis, eliminate the infeasible separation techniques and the corresponding alternatives from the list $\Omega_{s,t}$.

Step 5 A list $\Omega_{s,t}$ of separation techniques has now been identified for each relevant separation task t . From this, generate a separation superstructure for separation block s (see section 4.3.1.4 for details).

Step 6 For each reaction block, check if the reaction can be combined with a separation task in the proceeding separation block, if yes identify reactive separation as an alternative, and generate a superstructure fragment for this. The feasibility of reactive separations can be determined by the use

Separation technique	Class (based on)	Phases involved
Absorption	Solvent; External media	Gas-Liquid; Gas-Gas
Adsorption	External media	Gas-Liquid
Pervaporation	External media	Vapor-Liquid
Filtration	External media	Solid-Liquid
Gas Sep. membrane; Liquid membrane	External media	Gas; Liquid
Crystallization	Property difference	Solid-Liquid
Desublimation Sublimation	Property difference	Gas-Solid
Partial Condensation; Flash/Evaporation	Property difference	Vapor-Liquid
Distillation	Property difference	Vapor-Liquid
Pressure swing dist.	Property difference	Vapor-Liquid
Distillation + decanter	Property difference	Vapor-Liquid + Liquid-Liquid
Extractive distillation	Solvent	Vapor-Liquid
Azeotropic distillation	Solvent	Vapor-Liquid- Liquid
Liquid-Liquid extraction	Solvent	Liquid-Liquid
Supercritical extraction	Solvent	Fluid-Vapor-Liquid

Table 4.2: List of separation techniques suitable for the removal of a chemical species from a mixture

of reactive phase diagrams (these diagrams can be obtained by using the tool described in section 3.3.3).

Step 7 Combine the superstructure fragments generated in steps 3, 5 and 6, by using the information of the block diagram from step 2. Thereby, a combined superstructure is generated. Identify streams where the main species are unconverted raw materials and inerts, if such a stream(or streams) is identified it should be recycled to the relevant reaction block.

Step 8 The initial feasible flowsheet is identified:

- For reactions, select arbitrarily or if known, the most promising alternative.
- For separation blocks, sequence the tasks and select the best separation alternatives according to either the insights based algorithm (Jaksland *et al.*, 1995) or if the required information is available, the driving force based algorithm (Gani and Bek-Pedersen, 2000). See section 4.3.1.5 for further details.

Step 9 Apply the design algorithms described in section 3.3.3 to obtain the design details needed, so that the simulation and structural optimization steps can be carried out (see also section 4.3.1.6). Input streams to any unit operation (such as a reactor or a separation unit) requiring changes of condition (in terms of temperature and/or pressure) are identified as streams needing utility operations. Add the necessary utility operations (i.e. heating, compressing, etc.) for these streams.

Step 10 The final step before the problem solution phase, is a validation through simulation of the complete initial flowsheet. The approach used in the problem solution phase utilizes an environment with a steady-state flowsheet simulator integrated with an NLP-optimizer. The validation step is carried out in the same environment, and using the same thermodynamic models as will be used during the problem solution. If the initial flowsheet is not feasible (from a simulation point of view), either new design variables must be determined or another initial flowsheet is selected.

It should be noted from the above step by step algorithm that it is possible to go back from a later step to an earlier step, thereby giving the user the opportunity to correct for possible omission or error. It is also possible to by-pass some steps, for example, steps 2 to 7, if a superstructure is already available. In the following subsections more details are provided for some of the steps in the algorithm. An example of application of the algorithm are given in chapter 5, section 5.4.1.

4.3.1.1 Problem formulation and initialization

The main steps in formulating the problem is actually part of the pre-analysis, and especially the considerations given in section 4.2.1 are important. Here the problem type (novel design or retrofit) and the objective(s), which are usually given from outside (i.e. the company's business unit or the company contracting you), are identified. Also the other parts of the pre-analysis helps in identifying knowledge, which should also be taken into account when formulating the problem. An example could be knowledge on thermal stability of the product, which would lead to constraint on temperature. The most concise form of the problem formulation is obtained by using mathematical formulation as much as possible, for example: Identify a novel flowsheet layout for producing X at a purity of 99 %, while maximizing the profit:

$$\begin{aligned} & \max(\text{Product Income} - \text{Production Cost} - \text{Annualized Cost}) \\ & \text{s.t.} \\ & T_{\forall \text{ streams with Product X}} \leq 350 \text{ K} \\ & \quad \vdots \\ & \text{Product X flowrate} = 100 \text{ kg/hour} \end{aligned}$$

Note that this formulation is the beginning of the mathematical problem to be solved in the problem solution phase. However the proceeding steps in the algorithm will add extra equality and inequality constraints to this formulation.

In addition to the problem formulation a master list Ω of separation techniques to be used in step 4 should be created. Each entry in the list is similar to the entries in Table 6 in Jaksland (1996) (Table 6 is reprinted in appendix A), representing a separation technique along with the feasibility limits of difference in properties. By comparing these limits with the actual property difference for a binary component pair in question and the feasibility of the separation technique in the entry for this binary pair can be determined. The list Ω is considered updatable, as a starting point, however, it will have the same entry as in Table 6 of appendix A. The entries are updatable in terms of new knowledge about the separation techniques might change the limits. Note that new separation techniques can also be added and, Table 4.2 may not be considered complete by all industry areas who want to apply this framework, also it could be that some separation techniques are decided to be undesired for specific synthesis problem. The following steps can be used to generate Ω :

- I. Copy all separation techniques from Table 4.2 (with all the information from Table 6 in Jaksland (1996)) to list Ω
- II. Add extra, desired techniques, together with their property limits.
- III. Remove separation techniques that are marked as undesired by the user. An example could be a technique that is undesired in the company due

to lack of expertise, or that only a fixed selection of techniques can be considered, due to time limitations. Note that this screening can also be carried out on a separation task level in step 4.

- IV. Consideration of external media (such as membrane based separations) depend on knowledge and/or experimental evidence of the existence of a suitable external media. Therefore, unless information of a specific external medium has been identified during pre-analysis (specified, or available through a knowledge-base), separation techniques based on the use of external media are eliminated from Ω . Note that if information is available for one or more specific binary component pairs this elimination should be carried out during the generation of $\Omega_{s,t}$ in step 4 instead.

Note Ω can be regarded as customized for the user and therefore be stored for later use.

4.3.1.2 Division of the process into blocks

Step 2 identifies the reaction and separation blocks that need to be considered. In the case of solving a retrofit design problem these blocks are often easily identified, and the problem can be solved with two different strategies: a) the rest of the flowsheet is included in the simulation/optimization without any design variables assigned. b) only the identified blocks are included, in which case blocks that are not connected can be solved separately. In the case of a new flowsheet, no automatic procedure exist for the division into blocks, which therefore is largely dependent on user interaction. However, the following guidelines may be used:

- Each reaction in the process represents a potential reaction block.
- Based on stoichiometry some reactions will take place simultaneously and are therefore assigned to the same block.
- A reaction block is usually preceded by a separation block.
- If production of undesired byproducts can be avoided by the removal of certain intermediates, a configuration of 2 reactions blocks with a separation block in between for the removal of the intermediate, can be considered.
- The division into blocks can be started with a separation block for removal of inerts.

4.3.1.3 Separation alternatives

Assume that separation block s identified in step 2 has NC_s components entering. Then the total number of binary component pairs in block s are:

$$|BP_s| = \sum_{i=1}^{NC_s-1} i \quad (4.1)$$

Note, however NC_s might be changed by the introduction of MSA's into the separation block. In step 4 a set of relevant separation tasks T_s has to be generated. If the component mixture in block s is to be separated into pure compounds, the number of separation tasks required are bounded by:

$$NC_s - 1 \leq |T_s| \leq |BP_s| \quad (4.2)$$

Often, however, complete separation into pure components are not required for all components. Consider for example, a pair of components that act as reactants in the same reaction block (this could be the block proceeding the separation block or it could be an earlier block in which case the compounds can be recycled back to that block). Usually there is no need to separate such a pair, and therefore, this separation task is redundant. T_s can now be generated according to:

1. Add all the corresponding tasks given by the binary pairs in BP_s to T_s
2. Remove, by user interaction, all the redundant elements (tasks) from T_s

4.3.1.4 Generating fragments of separation superstructures

In step 5 a superstructure fragment representing the feasible separation sequences for block s is to be generated. The starting point is a connection going into the fragment and a list of separation techniques $\Omega_{s,t}$ for each separation task t in separation block s . The following three step (A to C) algorithm is carried out in a loop, with possible termination in step C:

- A. Identify the first separation task t from T_s either by using the insights based algorithm (Jaksland *et al.*, 1995) or if the required information is available, the driving force based algorithm (Gani and Bek-Pedersen, 2000). Consider, by user interaction, if other tasks should be considered as the first task. If yes, include them as an alternative branch in step B.
- B. For each of the feasible separation techniques in $\Omega_{s,t}$ for task t , use logical splitters in order to include the separation techniques in the superstructure fragment. The first time step B is carried through, the logical splitters are simply connected to the connection going into the fragment, the succeeding times, the splitters must be placed at each branch of the fragment.

- C. For each branch in the fragment keep track of specific branch list of T_s , then remove task t from T_s if then T_s is empty for all branches stop else goto step A.

Note that the size of the fragment is reduced by considering the following:

- As the sequencing of tasks proceeds certain tasks will become redundant (since the split for these tasks were performed implicitly in a previous task). The redundant tasks are removed from the list of tasks in this specific sequence.
- If a separation technique for a specific separation task is also separating species for which a split was undesired this technique is marked as less feasible for the specific task.
- Bypassing the separation block could be an alternative in the case where a separation block was placed before a reactor only to remove inerts.

4.3.1.5 Identification of initial feasible flowsheet

An initial feasible flowsheet has to be identified before the problem solution phase can be initiated. The procedure is similar to the one used in the generation of separation superstructure fragment. Therefore, the initial feasible flowsheet may be identified easily if relevant information is recorded already at the superstructure generation step. If this is not the case (for example if the step was bypassed), the initial feasible flowsheet can be identified by:

If information on driving force is available for all the separation operations in the superstructure (this can be determined by the approach described by Gani and Bek-Pedersen (2000)). This approach selects the separation technique with largest driving force at the feed mixture as the first operation, the second operation is related to the next largest driving force and this procedure is continued until all separation tasks have been assigned. The method is based on the following principles:

From phase compositions, separation efficiency, $S_{i,j}$, as defined by the authors can be computed:

$$S_{i,j} = 100 |y_i - x_i| \quad (4.3)$$

$S_{i,j}$ in equation 4.3 is the separation efficiency of component i with respect to separation technique j . When y_i and x_i in eq. 4.3 represent vapor and liquid compositions respectively, $S_{i,j}$ indicates if the separation is easy or difficult with respect to normal distillation. For example, if $S_{i,j}$ is close to zero, high purity separation would require large number of plates and energy consumption would be high, while, if $S_{i,j}$ is close to 100, high purity separation would be easy and energy consumption would be minimal. If a suitable pressure can be found to satisfy the separation efficiency criterion, normal distillation at a selected pressure or pressure swing distillation can be selected as feasible separation techniques.

As an alternative to the method of Gani and Bek-Pedersen, the method described by Jaksland for obtaining a feasible flowsheet can also be used (repeated use of Algorithm 2.1 to 2.6 by Jaksland (1996), the steps are listed in appendix B). The main steps using this method are:

- Identify candidate separation task, by determining the binary pair that has the largest property difference, hereby the candidate separation technique is also identified.
- Validate the feasibility by mixture calculations and separation unit simulation
- Screen, select and sequence tasks

4.3.1.6 Determination of equipment design details

The optimal flowsheet for the identified superstructure is determined through structural optimization, which requires simulation of unit operations. In order to be able to simulate the units, design values are needed (these values are not necessarily fixed, instead they can be used as initial estimates for the optimization problem). The feasibility of a separation technique or an initial flowsheet is also validated through simulation and estimates on design variables are needed for this. Typical design variables needed are:

- Equipment dimensions (reactor volume, etc.)
- For multistage units - number of stages and feed stage
- Operating conditions
- For MSA based separations - amount of solvent needed
- Heat addition and removal specifications

Part of the information listed above will already be available from the earlier steps, for example, conditions of operations and also reactor volume might be available already from the pre-analysis phase. Other information, may be given implicit by the problem formulation. For example, for the product this could be purity specifications (which can act indirectly as a specification for a distillation column). Also, the type of specifications needed will be dependent on the choice of process models used in the simulation and optimization. In some cases the user will be left with qualified guessing in order to determine valid design variables, but for a large number of different unit types textbooks on equipment design (for example by Perry and Green (1984) or by King (1980)) are available offering graphical and other algorithms for deriving the design variables. Furthermore, for the task of determining valid configurations for distillation columns various tools are available, some of which have been developed or further developed in this thesis (see section 3.3.3). These tools are also able to handle complex column configurations, i.e. extractive and reactive distillation.

4.3.2 Solvent based separation

The special case of determining an optimal flowsheet for solvent(MSA) based separations has been given extra attention in this PhD-project. The generic superstructure in figure 4.2 is proposed for handling removal of liquid species from liquid mixtures. The problem can be seen as a sub-problem to solving the problem of generating a complete superstructure. In the case where the synthesis problem is that of determining a substitute solvent, it defines the complete problem. The problem can be formulated as:

Given the identity of a chemical species that must be removed from a mixture, determine the optimal flowsheet with respect to separation efficiency, cost of energy consumption and compounds involved, and process/environmental constraints.

In order to derive the generic separation superstructure in figure 4.2 steps 1, 4 and 5 from the algorithm presented in section 4.3.1 are needed. Furthermore, in order to solve the problem the initial flowsheet and design variables also have to be determined. Table 4.2 lists most of the commonly known separation techniques suitable for the removal of a chemical species from a mixture. The separation techniques of Table 4.2 can be classified in terms of use of solvents, use of external media and those based on differences in properties of coexisting phases. Among those, which are based on differences in properties of coexisting phases, the separation techniques can be further classified in terms of identity of the coexisting phases (vapor, liquid, solid, supercritical fluid).

The following analysis was used to derive the generic separation superstructure: In step 1 the separation techniques in Table 4.2 is used to prepare a list Ω of separation techniques to be considered in the problem. If no knowledge or experimental evidence of the existence of suitable external media is available this can be removed from Ω (section 4.3.1.1). Furthermore, for most problems related to the removal of liquid species from liquid mixtures, separation techniques involving solids (such as crystallization, leaching, etc.) will be eliminated after pure component properties based analysis unless knowledge or experimental evidence to the contrary is available. Therefore in this case, crystallization may also be eliminated from Ω for problems related to removal of liquid species from liquid mixtures. Note that the eliminated external medium based separation technique or crystallization can always be inserted at a later stage.

After elimination of the separation techniques in Ω (from Table 4.2) based on steps 4.B and 4.C, the superstructure (shown in figure 4.2) representing the remaining alternatives is proposed. In figure 4.2, the binary integer variables y_i ($i = 1, \dots, 25 + N$) indicate the available alternatives. If the value of y_i is 1, then the alternative is considered while if the value of y_i is 0, the alternative is not considered. Table 4.3 lists the feasible set of flowsheet alternatives and the corresponding binary variables y that have values of 1. Note that this superstructure represents all alternatives covered by solvent-based separation

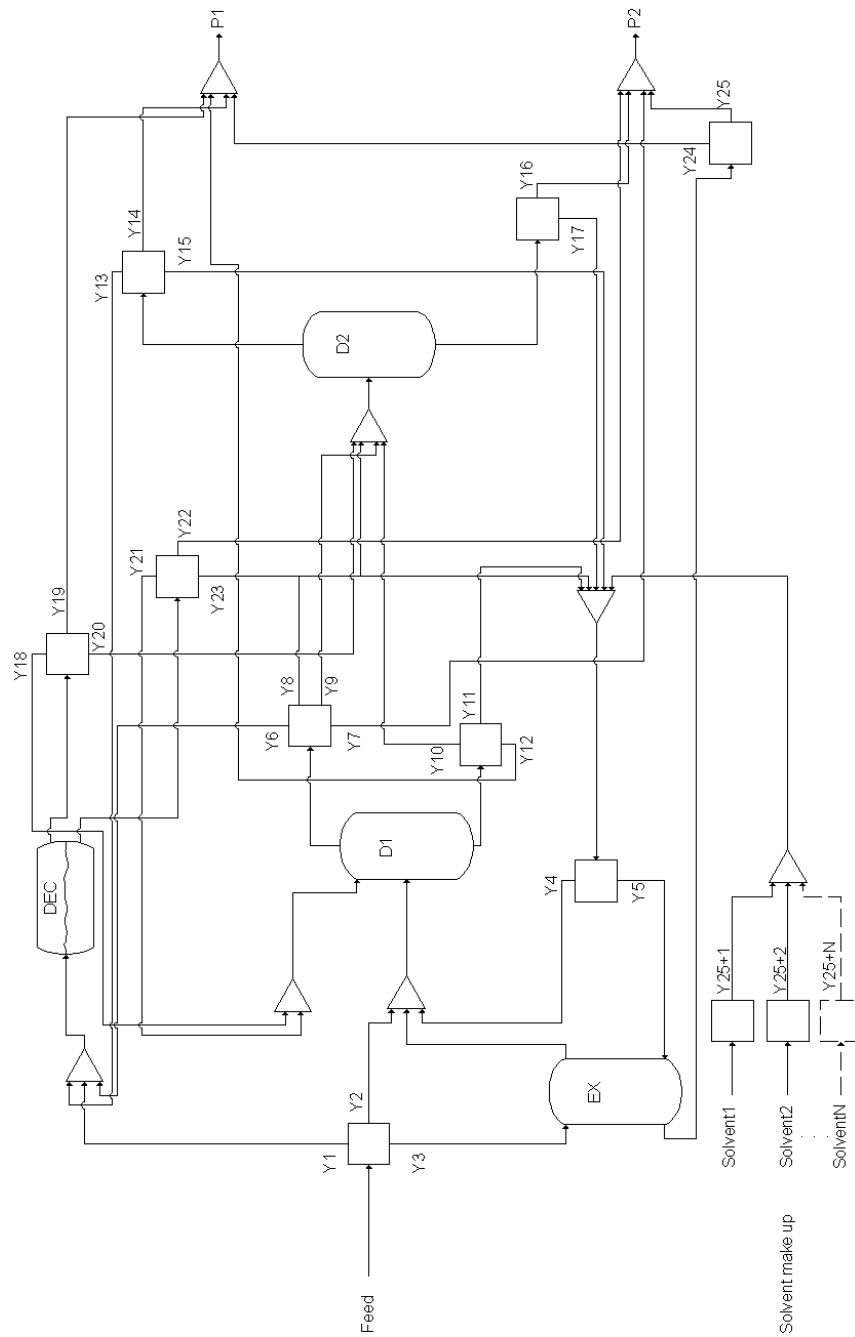

Figure 4.2: Generic superstructure for removal of liquid species from a liquid mixture

	y_1	y_2	y_3	y_4	y_5	y_6	y_7	y_8	y_9	y_{10}	y_{11}	y_{12}	y_{13}	y_{14}	y_{15}	y_{16}	y_{17}	y_{18}	y_{19}	y_{20}	y_{21}	y_{22}	y_{23}	y_{24}	y_{25}	
A	1						1					1														
B	1																									
C		1		1						1		1			1	1										
D			1	1			1			1			1													
E				1					1				1		1	1										
F					1					1				1			1									
G						1						1			1			1					1			
H			1		1		1				1															1
I				1	1			1		1					1	1										1

Table 4.3: Separation superstructure alternative (complete enumeration)

A	Conventional distillation	B	Decanter
C	Pressure swing distillation (low boiling azeotrope)	D	Pressure swing distillation (high boiling azeotrope)
E	Extractive distillation (low boiling azeotrope)	F	Extractive distillation (high boiling azeotrope)
G	Heterogeneous azeotropic distillation	H	Liquid - Liquid extraction + distillation (no azeotrope in extract)
I	Supercritical extraction		

y_i is the selection variables in the generic superstructure shown in figure 4.2.

techniques and those based on differences in properties of coexisting vapor and liquid phases. The total number of alternatives represented by this superstructure is given by:

$$N_F = N_{F,0} + \sum_{i=1}^{N_{st}} N_{S,i} \quad (4.4)$$

where $N_{F,0}$ is the total number of separation techniques not using solvents and $N_{S,i}$ is the total number of solvents to be considered for solvent based separation technique i . Note that the decanter may also be used to represent a crystallizer or a membrane (using external medium). The binary mixture property based analysis of step 4.D may further reduce (simplify) the superstructure. For example, if the binary mixture does not show a miscibility gap (such as found in benzene-water or butanol-water systems), use of a decanter followed by normal distillation is not feasible and therefore, eliminated as an alternative. Also, the mixture analysis from step 4.D may identify the presence of mutually soluble species in the mixture to be separated (indicating the presence of a solvent). If the difference between the liquid and vapor compositions is small over a pressure range reflecting the normal operating pressures for distillation columns, then normal distillation is not feasible and can be eliminated as an alternative.

For the solvent-based separations the first step is to identify suitable solvent alternatives (step 4.E) and then eliminate solvent-based separation techniques for which feasible solvent alternatives could not be found (step 4.F). For step 4.E, CAMD (Computer Aided Molecular Design) algorithm has been used, see section 4.3.2.1. If, after step 4.E, solvent alternatives are found, properties of the solvent will determine the type of solvent based separation it is applicable to. For example, solvents forming homogeneous vapor-liquid systems with the solutes refer to extractive distillation. If only such solvents are found, then separation techniques such as liquid-liquid extraction, azeotropic distillation, are eliminated from the superstructure (step 4.F).

4.3.2.1 Generation of solvent alternatives by CAMD

For the class of separation techniques that require the use of a solvent (mass separating agents) use of methodologies based on CAMD is recommended. In this work, a modified version of the CAMD algorithm developed earlier by Harper *et al.* (1999) has been used. This CAMD algorithm is able to design and select solvent alternatives that match a desirable set of specified properties. Since the specified set of properties may also include environmental properties, it is possible to design substitute solvents that are environmentally more benign than those being substituted (Gani and Harper, 1999).

The solution of the solvent design sub-problem (or generation of solvent alternatives) involves a number of stages. Figure 4.3 illustrates the main stages of the current CAMD algorithm of Harper *et al.* (1999). First the overall

objectives have to be identified and enumerated (that is, why do we need solvents and do we have multiple objectives?). The next stage is to formulate the CAMD problem in terms of which type of CAMD problem is being solved (solvent design, agent for miscibility, etc.). The next stages involves the detailed description of the solvent design problem in terms of design objectives and property constraints (upper limit, lower limit and/or desired values). Finally, in the problem formulation stage, property estimation methods needed for evaluation of property constraints and the design objectives are selected.

The CAMD solution stage involves finding molecules of the desired type having the desired properties. If the problem is of the selection type (i.e. finding candidates from a database of known compounds), the solution stage involves searching of one or more databases available in-house. This identifies the subset (if any) of compounds satisfying the property and molecule type constraints. This type of problem is classified as CAMS (Computer Aided Molecule Selection). If the problem is defined as a regular CAMD problem an algorithm is used to design molecules having the properties and types defined in the constraint selection and definition step.

After the design stage of the CAMD algorithm has been completed, the

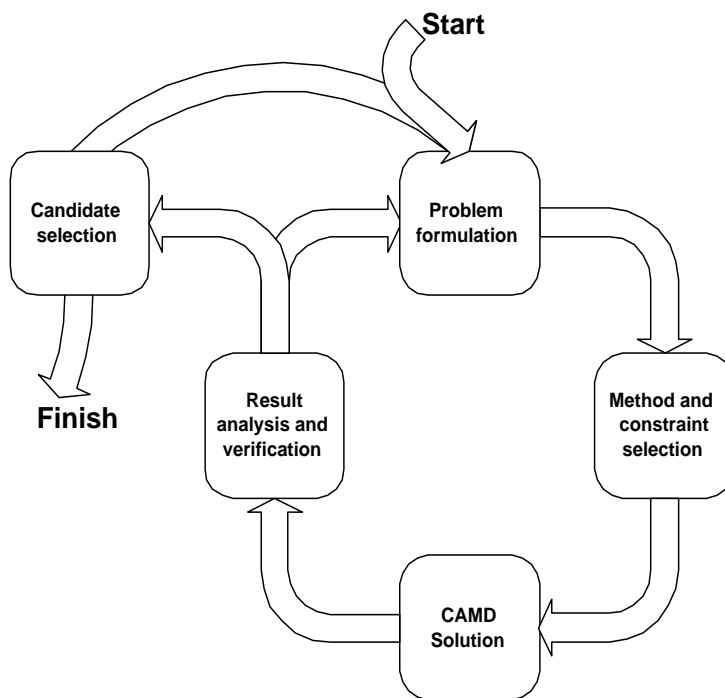

Figure 4.3: Flow diagram for the CAMD algorithm of Harper *et al.* (1999)

results will either be a list of solvent alternatives fulfilling the specified property criteria or an empty list if no solvents were found. In the latter case the problem may be reformulated either by changing (relaxing) the design constraints or by changing the overall design objectives, if possible.

If a list of solvent alternatives is obtained, the next step (analysis step) is to analyse them in order to identify the most promising alternatives. This analysis should be performed on the basis of the predicted properties as well as available external sources of data and tools (such as databases, mixture analysis tools and process simulation tools). The analysis should not be based purely on the predicted values as the reliability of the property estimation method usually varies from system to system. Also, a number of selection criteria are dependent on parameters (or properties) that cannot be directly estimated. Examples of such parameters are toxicity, price, availability and regulative standards of use. In order to evaluate environment, health and safety (EH&S) constraints for the solvent alternatives, databases such as CHRIS (Silver Platter Information Inc., 1998a), HSDB (Silver Platter Information Inc., 1998b) and RTECS (Silver Platter Information Inc., 1998c) are used. Search of these databases become more efficient if the molecular structure of the solvent alternatives can be linked to a CAS-NO (Syracuse Research Corporation, 1998).

When the list of solvent alternatives satisfying the design, performance and environmental constraints have been identified, the final selection is made. This step should ideally involve experimental or pilot plant studies. Based on the experiments, the final selection is made and the CAMD problem is considered solved. For the purposes of combined solvent design and separation process synthesis, however, the experimental or pilot plant study is recommended after the optimal flowsheet has been determined. That is, a solvent with its corresponding flowsheet and condition of operation.

4.4 Simulation and optimization

In the problem solution phase the mathematical problem, which has been set up through the steps in section 4.2 and 4.3, is solved. The problem to be solved is formulated as an optimization problem where the general form is given by equations 3.1 through 3.5. The design variables will usually be a combination of continuous and integer types, in a set of non-linear equations, therefore a MINLP solution strategy is required to solve the problem. The MINLP approach enables simultaneous solution of both discrete (topology) and continuous decisions (temperatures, flows, design variables, etc.). Note that if heat integration aspects for the utility operations added in step 9 are to be considered in the solution phase, equations for this can be added (see for example Duran and Grossmann (1986b)). Different strategies should be applied depending on the problem size.

- If the number of flowsheet alternatives (binary integer variables) remaining after the screening steps in section 4.3 is small and can easily be

enumerated, successive solutions of NLP sub-problems for each set of feasible binary variable values is applied. For each alternative, the optimal NLP sub-problem solution is obtained. The alternative giving the best solution is the optimal solution. In each sub-problem, the objective function and constraints are the same except for the constraints related to the process model equations.

- Otherwise the reduced MINLP problem must be solved, two different strategies has been investigated during this work:
 - MIPSYS/PC-NT (a disjunctive MINLP computer environment) developed by Kravanja and coworkers has been used. MIPSYS/PC-NT is a successor of PROSYN-MINLP by Kravanja and Grossmann (1994), in which the modified Outer-Approximation (OA) algorithm is adapted to the modeling and decomposition (M/D) strategy by Grossmann and Kocis (1989). It should be noted that the modified OA algorithm contains a number of strategies in order to reduce undesirable effects of unstructured non-convexities in the master problem. The code can also be used to apply multilevel MINLP, which is especially important, when the designer wants to perform the simultaneous heat integration.
 - Another approach for the problem solution featuring an interactive MINLP-solver (Henriksen *et al.*, 2000) was used in the combined framework. The interactive MINLP-solver is based on the decomposed MINLP solution method consisting of an outer-loop where an MILP master problem is solved and an inner-loop where a NLP sub-problem is solved. The non-linear equations are solved in the inner-loop NLP sub-problem for the continuous variables and "fixed" binary variables. In the outer-loop, at the solution of the NLP sub-problem, the non-linear equations are linearized and an MILP problem is solved to generate new values for the binary variables. In the interactive MINLP-solver, the NLP sub-problem is solved through a process simulator with optimization features. The MILP master problem is solved externally and an interface communicates between the outer-loop and the inner-loop. The interactive MINLP approach is described in detail in section 3.3.5.

Both strategies for solving the reduced MINLP-problem has their advantages and drawbacks. MIPSYS/PC-NT uses the GAMS (Brooke *et al.*, 1988) environment to solve the actual NLPs and MILPs. The problem is formulated through input files, and the system has library files with model equations (for units etc.). The main advantage is the special features for handling problems with numerical difficulties, the main drawbacks are that the standard models are sometimes simple, no rigorous thermodynamics is used and that lack of user-friendliness makes it difficult to set up the problem. The Interactive MINLP

approach uses a steady-state flowsheet simulator with an integrated SQP optimizer as described in section 3.3.5. The main advantages are the integrated environment (with the superstructure generation algorithm), use of rigorous unit and thermodynamic models and a more user friendly way of setting up the problem. Current limitations are that not all steps in the interface that communicates between the outer-loop and the inner-loop has been automated.

Note that application of the separation efficiency based design of the separation columns means that the integer variables related to design of the separation columns can be excluded from the optimization problem, at least, in the first attempt to determine the optimal flowsheet. According to Gani and Bek-Pedersen (2000), location of the feed plate relative to the maximum of the separation efficiency corresponds to the minimum energy requirement for a distillation column with N plates (where N can be any number that gives the required product purity). That is, the number of plates can be determined separately after the flowsheet configuration has been obtained.

APPLICATION EXAMPLES

5.1 Introduction

The application of the integrated process synthesis framework is illustrated through several illustrative examples in this chapter. Some of the examples focuses on a specific part of the framework (e.g. estimation of kinetics) in order to highlight the corresponding features of that part. Other examples aim at illustrating the general idea of integration (which is central to this thesis), by applying several parts of the framework in an integrated manner. The main focus for each example is summarized below:

- In section 5.2 the estimation of reaction kinetics using the reaction analysis tool is illustrated through two examples. A more complex example of this is given as part of the methanol synthesis example in section 5.5.
- Application of the algorithm for design of distillation columns is shown through an example in section 5.3. This example also shows how the integrated process synthesis framework is providing the right environment for easy utilization of the results from the algorithm.
- The examples in section 5.4 focuses on the hybrid approach which is combining thermodynamic insights based approaches and mathematical programming based methods for process synthesis. These examples show how, through the integrated framework, the hybrid approach is beneficial for solving process synthesis problems.
- Using the methanol synthesis process as an example section 5.5 shows how the various algorithms and tools presented in this thesis work together as an integrated process synthesis framework.

5.2 Reaction kinetics estimation

The reaction analysis tool (described in 3.3.1) has been used for the estimation of reaction kinetics. These illustrating examples of increasing problem com-

plexity is presented, starting with hydrolysis of ethylene oxide and followed by a problem with 5 pseudo compounds and 2 reversible reactions.

5.2.1 Ethylene glycol

Ethylene glycol can be produced by the hydrolysis of ethylene oxide, the reaction is catalyzed by the presence of sulfuric acid:

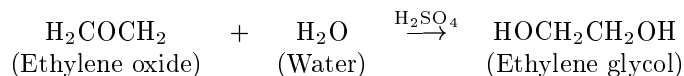

Before ethylene glycol can be produced on a large scale, a rate expression for the reaction must be determined in order to carry out the design of the reactor equipment. Experimental reaction data for this reaction is given by Fogler (1992).

Early experiments has revealed that at temperatures below 40 °C the reaction rate is low, while at high temperatures there is a significant formation of by-product. From this information it is decided to carry out the reaction isothermally at 55 °C. A batch experiment was carried out by mixing 500 mL of a 2 mol/L ethylene oxide solution with 500 mL of water containing sulfuric acid. The mixture was maintained at 55 °C and the concentration of ethylene glycol was measured as function of time.

The data is given in Table 5.1, along with the corresponding concentration of ethylene oxide.

The reaction analysis tool (see section 3.3.1) is well suited for estimation of reaction kinetics for the type of experimental data shown in Table 5.1. However, it is always recommended to analyze the available information before starting the estimation:

Time [min]	C _{Et-O} [mol/L]	C _{Et-Gl} [mol/L]
0	1.000	0.000
0.5	0.855	0.145
1	0.730	0.270
1.5	0.624	0.376
2	0.533	0.467
3	0.390	0.610
4	0.285	0.715
6	0.152	0.848
10	0.043	0.957

Table 5.1: Concentration of ethylene oxide (Et-O) and ethylene glycol (Et-Gl) as function of time, data adapted from Fogler (1992).

- The mixture is homogeneous and no solid catalyst with active sites is present. Therefore it is expected that the kinetics can be modeled with a standard mass action expression. The general equations for a batch reactor with mass action kinetics using the arrhenius expression for the specific rate is given by equations 3.8 to 3.11.

Mass balance for compound j:

$$\frac{dC_j}{dt} = R_j^{net} \cdot V \quad (3.8)$$

where,

$$R_j^{net} = \sum_{i=1}^{NC} r_i \cdot SC_{j,i} - \sum_{i=1}^{NC} r_i^{rev} \cdot SC_{j,i} \quad (3.9)$$

$$r_i = k_i \prod_{i=1}^{NC} C_j^{\alpha_{i,j}} \quad (3.10)$$

$$k_i = A e^{(-E/RT)} \quad (3.11)$$

- Data is only available at one temperature, therefore the activation energy (E) is set to zero to eliminate the temperature dependence of the arrhenius expression (equation 3.11).
- In the above experiment the concentration of water is high at all times so that zero order kinetics ($\alpha_{i,j} = 0$) for water can be expected.
- Looking at the reaction stoichiometrics for the reaction, the reaction order with respect ethylene oxide is expected to be 1, therefore this is used as an initial value in the estimation. Once a value for the pre-exponential factor has been estimated, the reaction order can be included in the reaction expression to confirm if the first order kinetics assumption is correct.

Considering the above analysis the only parameter to be estimated is the pre-exponential factor of equation 3.11, this is easily obtained done using the reaction analysis tool. The initial value for this factor was set to 1 and the final value was 0.314. Thereby, the rate expression becomes the following:

$$-r_{Et-O} = r_{Et-Gl} = 0.314/min \cdot C_{Et-O}$$

In appendix C application of the tool to the estimation problem is illustrated by screenshots. As described in section 3.3.1.2 the estimation problem is solved by first converting the differential equation(s) to an algebraic equation system,

and then solving a nonlinear optimization problem in order to determine the best values for the rate expression(s). The objective function to be minimized is a weighted sum of squares on the errors:

$$F_{OBJ} = \sum_i \sum_j \{w_{i,j} \cdot (C_{Est,i,j} - C_{Exp,i,j})^2\} \quad (5.1)$$

Where i is counting over time points and j over compounds, $w_{i,j}$ is the weight and was here calculated based on the standard deviation of the experimental data. The value of the objective function before and after solving the estimation problem is 4.48 and $6.24 \cdot 10^{-6}$ respectively, and the parity plots in figure 5.1 confirms the good correspondence between the measured and calculated concentrations. If the reaction order of ethylene oxide is included in the estimation problem a value of 1.00114 is estimated for the order, confirming that the reaction is of first order towards ethylene oxide. Furthermore, the effect of the reverse reaction can be evaluated simply by including pre-exponential factor for the reverse reaction in the estimation problem. If this is done, a very small value for the pre-exponential factor for the reverse reaction is determined ($< 1 \cdot 10^{-5}$) thereby indicating that it is all right to neglect the reverse reaction.

In the design and sizing of reactors, the reaction rate together with the desired conversion is usually the most important factors. For example, the volume of a CSTR is determined by the following equation:

$$V_{CSTR} = \frac{F_{Et-O,in} \cdot X_{out}}{-r_{Et-O,out}} \quad (5.2)$$

The rate expression determined above can be directly inserted in this equation. Often, a single CSTR is not very efficient (a high volume is required), but also

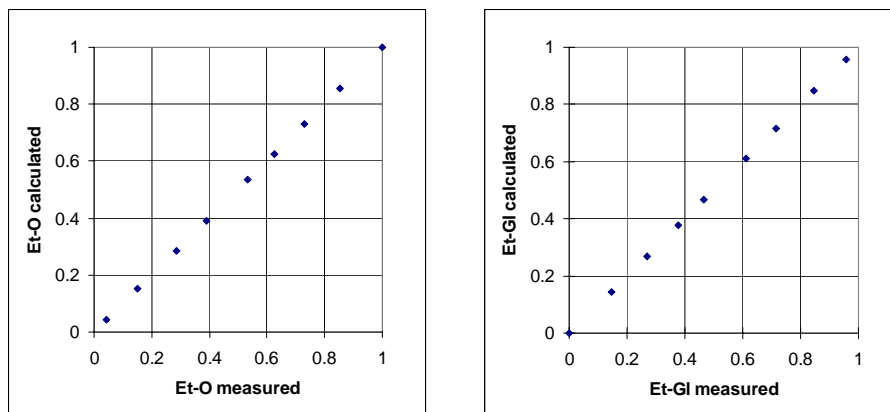
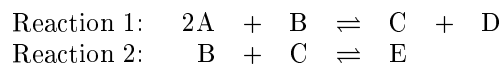

Figure 5.1: Parity plots (measured vs. calculated concentration) for ethylene oxide and ethylene glycol.

in the more complex designs the rate expression is required – for example, for solutions with multiple CSTRs in series, a PFR or in a design with recycle of reactants.

5.2.2 Multiple reactions

The task of estimating the kinetic parameters for the reaction in the previous subsection could also have been carried out by plotting the logarithm of the ethylene oxide concentration as a function of time, and then evaluating the slope of a straight line through the points. This however requires that the reaction order for ethylene oxide must be assumed before plotting. When the problem gets more complicated, for example, for multiple and reversible reactions, for unknown reaction orders and where influence of temperature must be considered, the determination of rate expressions is usually not possible just by short-cut or "back of the envelope" type of calculations. As an example consider, a system with 5 pseudo compounds (A, B, C, D and E) in aqueous solution. Two reversible reactions occurs for the system:



The corresponding reaction rate expressions are:

$$\begin{aligned} r_1 &= k_1 \cdot C_A^2 \cdot C_B \\ r_{-1} &= k_{-1} \cdot C_C \cdot C_D \\ r_2 &= k_2 \cdot C_B \cdot C_C \\ r_{-2} &= k_{-2} \cdot C_E \end{aligned}$$

where,

$$k_i = A_i \cdot \exp\left(\frac{-E_i}{T}\right)$$

and:

	Forward		Backward	
	A_i	E_i	A_i	E_i
Reaction 1	$4340 \text{ m}^6 / (\text{kmol}^2 \cdot \text{hr})$	61.0 K	$500 \text{ m}^3 / (\text{kmol} \cdot \text{hr})$	62.0 K
Reaction 2	$2500 \text{ m}^3 / (\text{kmol} \cdot \text{hr})$	68.0 K	$90 / \text{hr}$	89.0 K

These expressions together with the values of the constants can be used to calculate reaction data for a batch reactor, if a dynamic simulator is available. In ICAS (see section 2.4.3) the dynamic simulator called DYNMIM can be used to perform the necessary simulations. In appendix D the constructed data is shown, note that the molar holdups from the dynamic simulation have been converted into concentrations.

The reaction data as presented in appendix D can be used directly in the reaction analysis tool, however, first the components and reactions must be entered. Furthermore, information such as the parameter bounds, the reactor type, the measured values (time, temperature and concentrations) and their

weights must be specified. A procedure using the standard deviation of the concentrations is available for specifying the weights. As a starting point the reaction analysis tool always sets the reaction orders equal to stoichiometric coefficients of the reaction. It is recommended first to carry out the estimation with the reaction orders fixed to this and then at a later stage of fine tuning include the reaction orders in the estimation problem. Also it is recommended to consider simple models first if the mechanism is not known (mass action instead of LHHW expressions), and then adjust the expressions in an iterative manner to obtain the best fit. If overly complex expressions are considered in the beginning where nothing is fixed, this can often result in parameter non-uniqueness, since the information content of the experiments is lower than the information required (complexity) by the model. With the reaction orders fixed to the respective stoichiometric coefficients and initial values of 1000 for pre-exponential factors and 60 for activation energies, the following parameters were estimated:

	Forward		Backward	
	A_i	E_i	A_i	E_i
Reaction 1	$4336.5 \text{ m}^6 / (\text{kmol}^2 \cdot \text{hr})$	61.3 K	$481.2 \text{ m}^3 / (\text{kmol} \cdot \text{hr})$	51.7 K
Reaction 2	$2435.2 \text{ m}^3 / (\text{kmol} \cdot \text{hr})$	60.6 K	$85.2 / \text{hr}$	73.4 K

Again the objective function to be minimized is a weighted sum of squares on the errors (see equation 5.1), and the value was $1.4 \cdot 10^{-4}$. Furthermore in appendix D parity plots for the measured (calculated by DYN SIM) and estimated concentrations are shown. Note that the values for the estimated parameters differ from the corresponding predefined values, but not appreciably. The dynamic simulations were repeated with the estimated parameter values, the difference in calculated concentrations were less than 0.5 %.

Now, if the reaction orders are included one at a time into the estimation problem, values that differs slightly from the preset values are found. For example, an order of 2.00066 is found for the compound A in reaction 1, and the pre-exponential factors and activation energies also change. However, the value of the objective function does not improve much by this, and in such cases it may be better to keep the reaction order for A at 2, since this value is better explained from a physical viewpoint. The same trend is observed when the other reaction orders are included in the estimation problem. This example clearly establishes that the reaction analysis tool can indeed handle systems with multiple reversible reactions, where the temperature is influencing the reaction rate.

5.3 Distillation design

5.3.1 Separations in methyl-acetate production

This section illustrates the use of the separation design tool with special attention towards the equilibrium based algorithm (described in section 3.3.3.1) for

design of distillation columns . The mixture to be separated originates from the production of methyl-acetate. In Jaksland (1996) the synthesis of a methyl-acetate production process was presented, where a sequence of five distillation columns followed a reactor, in order to obtain methyl-acetate (purity 99.9 %) and water by reacting methanol with acetic acid. Note that Eastman Chemical Company in 1983 (Agreda *et al.*, 1990) have proposed the use of reactive distillation for methyl-acetate production. While the authors from Eastman Chemical Company report that a high purity of methyl-acetate is obtained directly, the same is not the case in the experiments by Pöpken *et al.* (2001). They report that the top product of the reactive distillation column consists of 80-90 % methyl-acetate with the rest being methanol, so that extra separation is needed to obtain high purity methyl-acetate. Furthermore, during the past few years, the market has changed so that hydrolysis of methyl-acetate to obtain methanol and acetic acid is more profitable (Pöpken *et al.*, 2001). Methyl-acetate is also a by-product in air oxidation of aromatic hydrocarbons, and also in the production of polyvinyl alcohol. According to Han *et al.* (1997) and Pöpken *et al.* (2001) it is more difficult to obtain high purity products for the reverse reaction (hydrolysis). Therefore, extra distillation column(s) are needed to obtain high purity products.

In Jaksland (1996) the first separation task after the reactor is a split with the key compounds being methanol and water. The composition of the reactor effluent is given in Table 5.2. Distillation was chosen as the separation task for this, but the design details for the column were not given by Jaksland. The equilibrium based column design algorithm can be used to determine the missing design details. As described in section 3.3.3.1, the input to the algorithm, in addition to the feed details are the desired product compositions, and an estimate of the reflux ratio. Also, for systems with four or more compounds, identification of the key compounds is also needed. For this system there are four compounds, the light key is methanol and the heavy key is water. With respect to the desired products the split between methanol and water should possibly be sharp, but different degrees of recovery are tested here. Furthermore, in its current form the algorithm also requires product specification for the non-keys, and these can not just be full or zero recovery. Therefore, the recovery in the top product for methyl-acetate is set to 99.99 % and for acetic-acid to 0.01 %.

Temperature	350 K
Pressure	1 atm.
Mole fraction, Methanol	0.37
Mole fraction, Acetic acid	0.37
Mole fraction, Methyl-acetate	0.12
Mole fraction, Water	0.14

Table 5.2: Composition of reactor effluent from methyl-acetate production according to Jaksland (1996).

The specified recoveries for the different runs are:

Recovery specification	Methanol, top	Water, bottom
1	98 %	98 %
2	99.5 %	98 %
3	99 %	99.5 %

Hence, the compositions for the desired products for recovery specification 1 are:

Mole fraction	Top product	Bottom product
Methanol	$7.470 \cdot 10^{-1}$	$1.438 \cdot 10^{-2}$
Acetic-acid	$7.622 \cdot 10^{-5}$	$7.190 \cdot 10^{-1}$
Methyl-acetate	$2.472 \cdot 10^{-1}$	$2.332 \cdot 10^{-5}$
Water	$5.768 \cdot 10^{-3}$	$2.666 \cdot 10^{-1}$

As mentioned above an estimate on the reflux ratio has to be given, alternatively an extra outer iteration loop could have been applied to the algorithm to determine the minimum reflux. The algorithm was applied at different reflux ratios, and the results can be seen in Table 5.3. As described in section 3.3.3.1, estimates of temperature and compositions on each plate as well the internal flowrates in the column are also obtained. Figure 5.2 shows the liquid compositions on the column trays for recovery specification 2 with a reflux ratio of 4, in appendix E plots of the vapor composition and internal column flows are given.

When the design algorithm is successful the obvious next step is to apply the design parameters and initial estimates in simulations of distillation columns. This is particularly easy in the integrated synthesis framework, since the design tool is part of ICAS (see 2.4.3) and therefore is able to expose its results to the rest

Recovery specification	Reflux	Overall recovery in top product	Stages	Feed stage
1	2	0.4854	12	9
1	4	0.4854	9	6
1	6	0.4854	8	6
2	2	0.4910	12	9
2	4	0.4910	10	7
2	6	0.4910	9	7
3	< 6.9	0.4870	no solution	
3	7	0.4870	12	9
3	10	0.4870	11	8
3	15	0.4870	10	7

Table 5.3: Design details for the methanol/water split column (number of plates and feed stage). Note that the feed stage is counted from the bottom (Reboiler is plate 1).

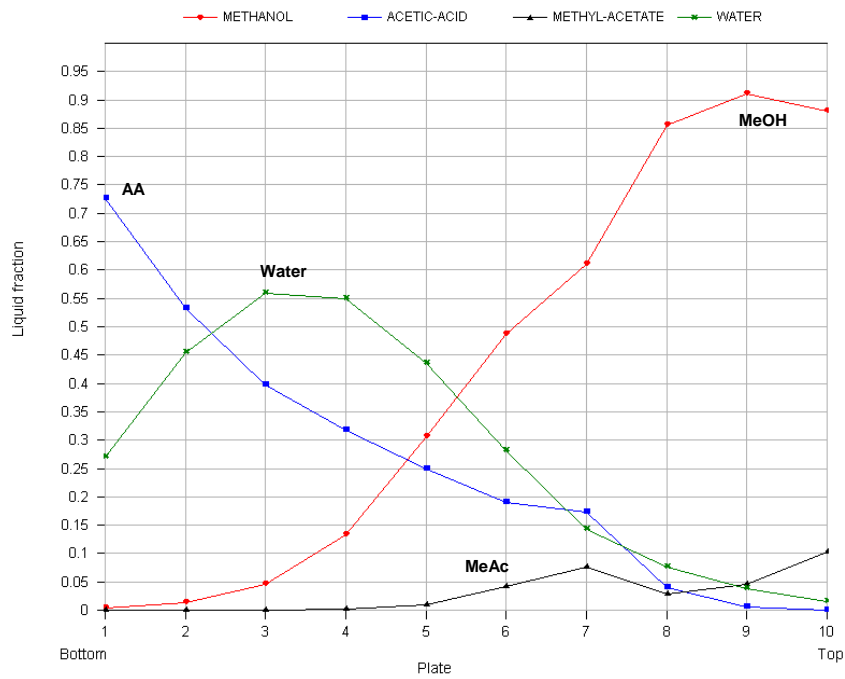

Figure 5.2: Tray vs liquid composition plot for the methanol / water split column, according to the eq. based design algorithm.

of ICAS through an interface. The purpose of the equilibrium based column design algorithm is to quickly determine the parameters and estimates – however these should be validated and possibly optimized to make sure that desired performance is obtained. Four of the obtained sets of design parameters has been used in simulations of a distillation column along with composition and temperature estimates. The thermodynamic model used is the original UNIFAC model with ideal gas phase (as was also the case for the design algorithm). In all simulations convergence was achieved just by utilizing the obtained parameters and estimates without any extra specifications or alterations. For a total feed flowrate of 100 kmole/hr, the simulation results is shown in Table 5.4. Although the design algorithm is a tool for determining good estimates for the design parameters and for obtaining easy convergence, it does not guarantee that desired purities/recoveries are also satisfied. It can be seen that the recoveries are close to what was desired. This is a trend when using the obtained parameters in simulations – the specified purities/recoveries (used by the design algorithm) are close to the values obtained for these variables through simulations. As described in section 2.4.2 an optimizer is available within the framework, and an optimization problem can easily be setup to obtain the desired purities. The results from the design algorithm therefore serves as good estimates, through simulations using Pro/II (Simulation Sciences Inc.), it has been confirmed that this is also valid for other simulation environments.

Recv. spec.	Reflux	Recovery in top [%]				Heat duty re-boiler [10^6 kJ/hr]
		MeOH	HOAc	MeAc	Water	
1	2	97.34	$2.43 \cdot 10^{-2}$	99.9990	3.69	4.7
1	4	97.72	$9.73 \cdot 10^{-3}$	99.9954	2.74	8.1
2	4	99.24	$9.57 \cdot 10^{-3}$	99.9994	2.68	8.2
3	10	98.94	$2.05 \cdot 10^{-3}$	99.9999	0.67	18.3

Table 5.4: Simulation results for the MeOH / Water split column.

5.4 Hybrid approach to process synthesis

In chapter 4 a methodology utilizing thermodynamic insights and mathematical programming based synthesis algorithms was presented, thereby combining them into a hybrid approach. This section illustrates with two examples how this hybrid approach is applied in an integrated framework.

5.4.1 Production of Cyclohexane

Cyclohexane can be produced by hydrogenation of benzene:

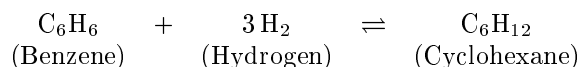

For the production of cyclohexane, a high conversion reactor with conversion $> 95\%$ is usually available. For the sake of this example, production of cyclohexane with reactors featuring conversions of 70% and 80% respectively, are considered. Due to this reason the recovery of product (cyclohexane), which could usually be carried out with a flash unit (for conversion $> 95\%$, flowsheet is shown in figure 5.3) becomes more difficult and at least one extra distillation column is necessary to obtain the desired product purity (99 mole% or higher in cyclohexane).

The feedstocks available are given in Table 5.5, where it can be noted that the hydrogen feed contains very little methane as an impurity (hydrogen with methane is available at low cost at the plant).

	Feed 1	Feed 2
Temperature	311 K	311 K
Pressure	10 atm.	33.45 atm.
Molefraction		
Benzene	1	
Hydrogene		0.975
Methane		0.025

Table 5.5: Feedstocks available for cyclohexane production.

In order to maintain the conversion for the reactors considered, the following specifications must be obeyed:

- Reactor operating conditions must be kept at 497 K and 33.45 atm.
- The molar flowrate ratio of hydrogen to benzene ($F_{hyd,reactor}/F_{benz,reactor}$) must be between 9 and 14.

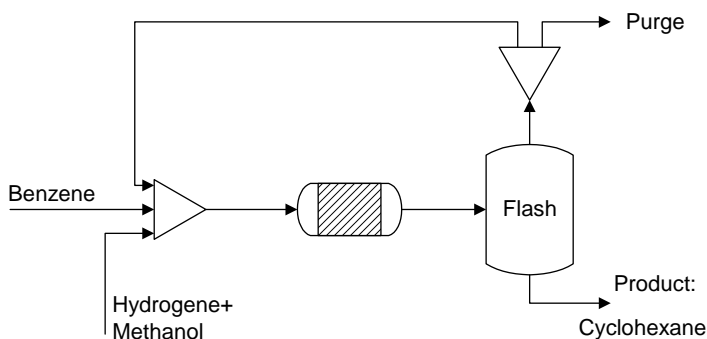

Figure 5.3: The original flowsheet for cyclohexane production.

5.4.2 Generation of superstructure

The algorithm described in section 4.3 will now be applied to generate a superstructure for the cyclohexane process, considering the two lower conversion reactors. The step numbers used below, refers to the steps of the algorithm given in section 4.3.1.

Step 1 Information about compounds present in the process are given, the desired product and the available raw materials have been identified. Also from the known information given above a preliminary problem formulation can be derived. The design problem can be considered as retrofit, by treating the flowsheet in figure 5.3 as known data. The problem can now be formulated as:

Identify the optimal flowsheet using either the 70 % or 80 % conversion reactor while maximizing profit. The flowsheet set up with the flash separation is maintained, and the desired product purity must still be satisfied.

With respect to the list Ω of separation techniques to be considered, it is set equal to those listed in Table 4.2 (see section 4.3.1.1). Often, especially for the retrofit case, some undesired techniques may be removed at this point. For example:

The reason for using the lower conversion reactors was a temporary breakdown of the high conversion reactor. Use of low conversion reactors will only take place if it can be carried out without buying new separation equipment.

In this case the Ω list, should be equal to the separation equipment available but not currently in use at the plant.

Step 2 Identification of the reaction and separation blocks is straight forward, a reaction block is placed around of the original reactor. Furthermore a separation block is added after the flash separation in order to achieve the desired purity, the resulting diagram is:

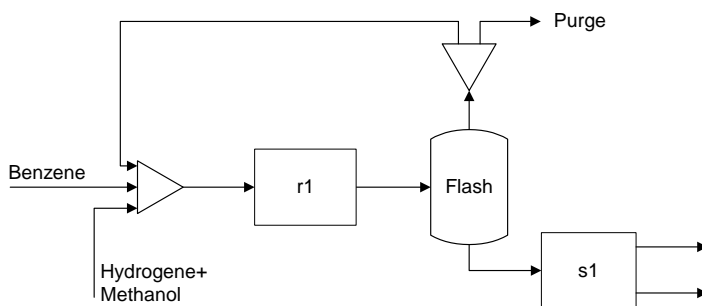

Step 3 For reaction block r1 two alternative reactors are available (70 % and 80 % conversion). The reactors are modeled by simple conversion reactors in this example so no more information is needed here. A superstructure fragment for r1 is now generated by using one logical splitter as shown

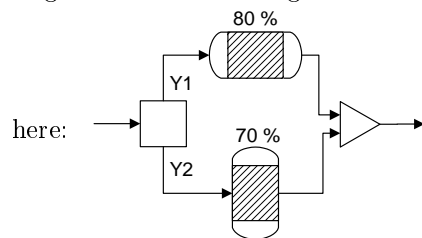

The binary variables y_1 and y_2 are assigned to the logical splitter (as described in section 2.2.1).

Step 4 For separation block s_1 the relevant separation tasks T_{s_1} must be enumerated. It is assumed that original configuration takes care of removing hydrogen and methane so that these are in insignificant amounts in the stream coming into s_1 . Therefore the only relevant separation task is the benzene/cyclohexane pair. Now a list of separation techniques to be considered for this pair is generated:

- 4.A. The master list Ω is copied to the local list Ω_{s_1, t_1} .
- 4.B. From the pure component properties based analysis (Algorithm 1.1-1.4 in Jaksland (1996), these steps are listed in appendix B) mainly all the techniques involving solids (filtration, crystallization etc.) are eliminated, due to the small difference in melting points. The remaining techniques are either external media or distillation based.
- 4.C. A literature search for external mediums, leads to poly (vinyl chloride)-graft-poly(butyl methacrylate), Yoshikawa and Tsubouchi (1999), that can be used in pervaporation. The rest of the external media based separations are eliminated from $\Omega_{s, t}$.
- 4.D. The binary mixture properties based analysis reveals the presence of a minimum boiling azeotrope between benzene-cyclohexane, as shown in figure 5.4. The composition of the azeotrope is pressure dependent, as can be seen in figure 5.5, indicating that a pressure swing configuration is feasible. However the driving force is very low, especially in the benzene rich end and at pressures above 3 atm., this pressure dependence can be exploited in pressure swing distillation. The analysis also revealed that at low pressures in the cyclohexane rich end the driving force is quite high, this could be exploited by simply recycling the low boiling azeotrope back in the reaction loop. Finally the mixture analysis also screened out the LLE and VLE based separations (from the list given in Table 4.2).

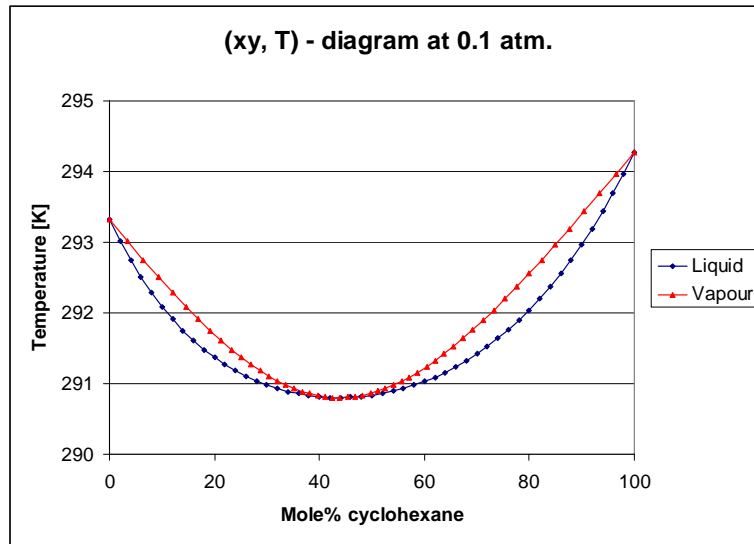

Figure 5.4: Txy diagram for cyclohexane / benzene at 0.1 atm.

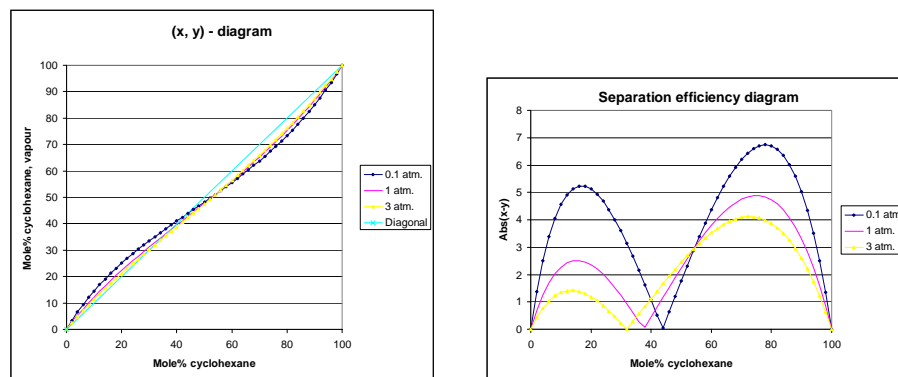

Figure 5.5: xy (left) and separation efficiency (right) diagrams for the cyclohexane / benzene pair at different pressures

- 4.E. Remaining separation techniques requiring mass separating agents (solvents) is extractive distillation. Vega *et al.* (1997) has recommended 5 high boiling solvents to be used for this task, with n-methyl-2-pyrrolidone as the most suitable for obtaining pure cyclohexane. Note that these compounds and others have also been identified as potential solvents, using the CAMD framework of Harper *et al.* (1999). Also with CAMD, low boiling solvents can be found.
- 4.F. The process design tool (described in section 3.3.3) was used to generate the residue curve maps for the solvent alternatives identified in step 4.E. It can be seen from figure 5.6 that n-methyl-2-pyrrolidone can be used as an entrainer in a 2 column extractive distillation configuration. Also from residue curves it is found that for low boiling entrainer alternatives 3 distillation columns is needed to achieve efficient separation, therefore these solvents are eliminated as alternatives.

Step 5 With this information three alternatives for separating cyclohexane from benzene can be set up in a superstructure fragment (see figure 5.7). For the membrane based (pervaporation) separation alternative a distillation column is added in front in order to decrease the size/cost of the membrane. The three alternatives are:

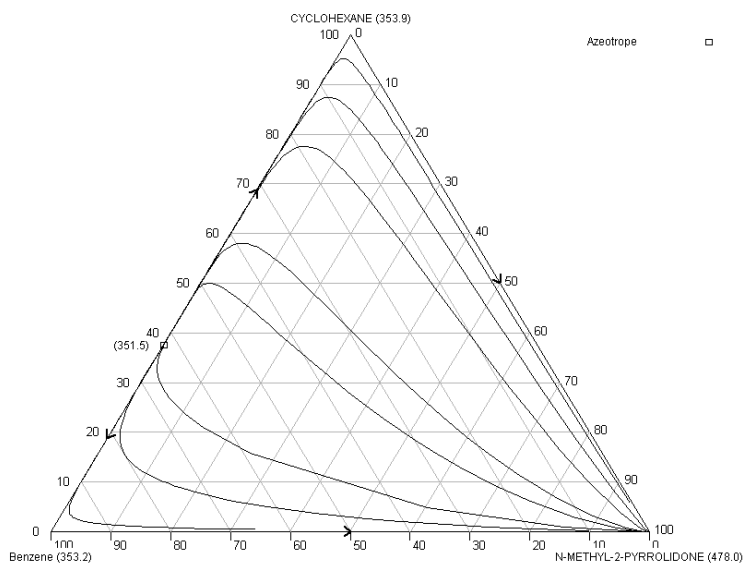

Figure 5.6: Residue curve map for cyclohexane/benzene separation with n-methyl-2-pyrrolidone as solvent at 1 atm.

- A single distillation column and recycling a stream with the azeotropic composition
- One distillation column with a membrane based separation for "breaking" the azeotrope.
- An extractive distillation configuration with n-methyl-2-pyrrolidone as the solvent.

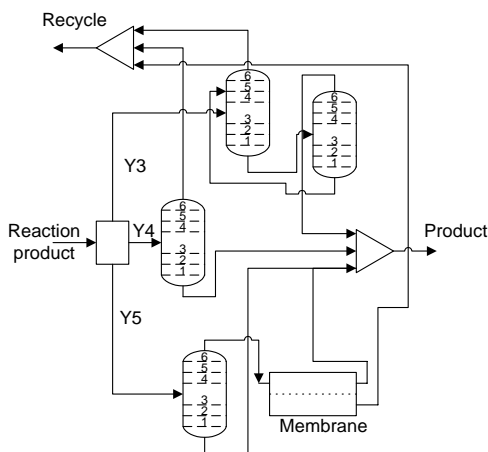

Figure 5.7: The superstructure fragment for the separation block.

Step 6 No indication of a possible reactive separation configuration was found.

Step 7 By using the block diagrams and the two generated superstructure fragments a superstructure is generated, as shown in figure 5.8. The benzene rich stream is recycled back to the reactor.

Step 8 For the initial flowsheet the 70 % conversion reactor was selected and the insights based algorithm (Jakslund *et al.*, 1995) suggested to select the membrane based separation.

Step 9 The initial specification values used for in the flowsheet in addition to those already given by the problem formulation, is shown in Table 5.6.

5.4.3 Structural optimization

The superstructure has now been generated. In order to find the optimal solution, the first step is to write the mathematical problem formulation that can be input to the solver. The alternatives in the superstructure and the non linear nature of some of the unit models as well as the thermodynamic model requires application of a MINLP solver. The solver used here is the "interactive MINLP solver" described in section 3.3.5. This solver minimizes the objective

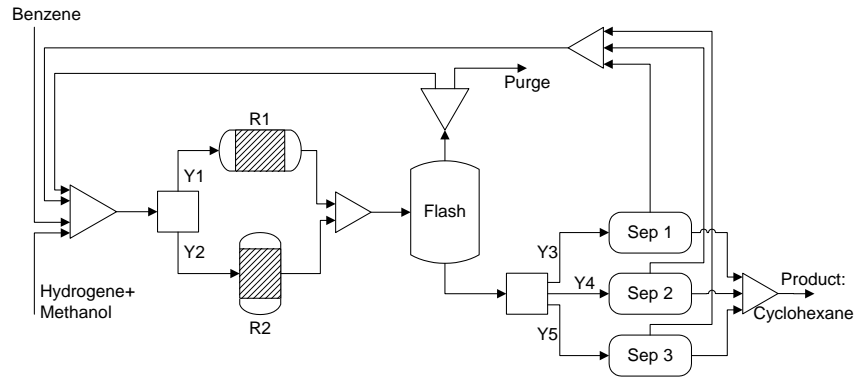

Figure 5.8: The complete superstructure is obtained by combining the two superstructure fragments.

Unit	Specification	Value
Flash	Temperature	322 K
	Pressure	33.45 bar
Distillation	Plates	30
	Feed plate	16
	Pressure	0.1 bar
	Reflux	5
	Btm. Temp.	294 K
Inner loop	Purge Fraction	0.1

Table 5.6: Specification values used

function (cost - income), therefore, a negative objective function value indicates a positive profit. The mathematical problem formulation now becomes:

$$\begin{aligned}
 F_{OBJ} &= \min \{C^T \mathbf{y} + f(\mathbf{x})\} \\
 &= \min \{-C_{cyclohexane} * F_{cyclohexane} - C_{heat} * Q(prod)_{reactor} \\
 &\quad + C_{heat} * (Q(add)_{dist} + Q(add)_{preheating reactor}) + C_{cooling} \\
 &\quad * (Q(rem)_{dist} + Q(rem)_{flash}) + C_{benzene} * F_{benzene} \\
 &\quad + C_{feed 2} * F_{feed 2} + C_{purge} * F_{purge} + y_i * C_{reactor i} \\
 &\quad + y_i * C_{separation i}\}
 \end{aligned}$$

s.t.

$$\begin{aligned} & \text{Composition of cyclohexane in product} \geq 0.99 \\ & 9 \leq \text{Hydrogen/Benzene ratio in stream to reactor} \leq 14 \\ & y_1 + y_2 = 1 \\ & y_3 + y_4 + y_5 = 1 \end{aligned}$$

The mass and energy balances for individual units and the overall flowsheet alternatives are included in the model equations in the process simulator.

The following design variables were selected as optimization variables:

- Purge fraction in the reaction loop (F_{H_2}).
- Flowrate of feed 2 ($PF_{inner\ loop}$).
- Temperature in the first column ($T_{col1\ btm}$) – to meet the desired purity.
- Reflux ratio in the distillation column(s) (R) – to have a handle on energy consumption.

The values of the cost constants is shown in Table 5.7.

$C_{cyclohexane}$	31.877	MU/kmole
$C_{benzene}$	24.874	MU/kmole
$C_{feed\ 2}$	0.5	MU/kmole
C_{heat}	8.0e-6	MU/kJ
$C_{cooling}$	0.7e-6	MU/kJ
C_{purge}	1	MU/kmole
$C_{reactor\ y_1; y_2}$	200, 100	MU/hr
$C_{separation\ y_3; y_4; y_5}$	188+95; 188; 178+235	MU/hr

Table 5.7: Values of cost constants. MU - monetary unit

In the "interactive MINLP solver" the MILP master problem is obtained by linearization at the optimal point from the NLP sub problem, while, the NLP sub problem is set up directly in the ICAS system (as described in section 3.3.4). The MILP master problem was solved with GAMS and an input file used for this purpose is given in appendix F. The solution summary can be seen in Table 5.8. In this table, the first column 'inner' refers to the NLP solution and 'outer' refers to the MILP solution. The second and third columns show the value of the structural and continuous design variables respectively. The optimal flowsheet employs reactor 2 (with 80% conversion) and separation scheme 1 (with one distillation column). Note that heat integration was not considered.

Iteration	Binary variables	NLP-solution	FOBJ
1. Inner	y2, y5(70% conv, membrane)	$F_{H_2} = 714.08; PF_{inner\ loop} = 0.05$	380.20 MU/hr
1. Outer	y1, y4(80% conv, 1 dist column)	MILP Evaluation	741.74 MU/hr
2. Inner	y1, y4(80% conv, 1 dist column)	$F_{H_2} = 701.41; PF_{inner\ loop} = 0.05$ $T_{col\ botm} = 294.12; R = 7.2$	705.07 MU/hr
2. Outer	y1, y4(80% conv, 1 dist column)	MILP Evaluation	705.07 MU/hr

Table 5.8: Solution summary for cyclohexane production using the Interactive MINLP.

F_{H_2} = Total flowrate of hydrogen feed; $PF_{inner\ loop}$ = Purge fraction in inner loop;

5.4.4 Separation of acetone from chloroform

Acetone-chloroform is a well-known binary azeotropic mixture. Benzene, which forms a homogeneous azeotropic system with acetone-chloroform, has been reported in the literature as a solvent for extraction of acetone. Benzene, however, cannot be used due to environmental concerns (carcinogenic and tumorigenic, (Silver Platter Information Inc., 1998c)). The integrated solvent design and process synthesis methodology which was described in section 4.3.2 can be used for solving problems of this type.

Also in this example the hybrid algorithm for process synthesis has been applied and the example will especially highlight the integration of solvent design and process synthesis with respect to determining the optimal flowsheet for separation of acetone from chloroform taking into account, energy consumption and environmental constraints. The superstructure presented in figure 4.2 will be used for this purpose. During the solution of the problem it will not be attempted to minimize the environmental impact. Instead, the solution will satisfy a set of environmental constraints (the selected solvent should not be subject to the same environmental concerns as benzene).

The algorithm presented in 4.3.1 is applied again, the walk through description will not be as detailed as in the previous example and also some steps are bypassed as no reactions need to be considered. Where ever step numbers appear in the text they refer to the algorithm. In step 1. the problem is formulated: Eliminate the usage of benzene as the entrainer so that the process will still be able to achieve the same separation or better.

As a starting point the list of separation techniques corresponds to those given in Table 4.2. The flowsheet division into blocks results in one separation block. Furthermore step 3 is bypassed as no reactions are present. In step 4 the only separation task is the acetone / chloroform task. After the screening in step 4.A the remaining separation techniques are the external media based techniques as well as extractive and pressure swing distillation. No information on an external medium that could be used to separate acetone from chloroform in a membrane-based separation was found, so the external medium based separation techniques are eliminated. The binary mixture property based analysis (step 4.D) validates the presence of an azeotrope (figure 5.9b). Figures 5.9a, 5.9c-5.9d show the phase behavior for the binary system at pressures of 0.5 Bar, 5.0 Bar and 40 Bar, respectively. It is interesting to note that except for high-pressure (40 Bar), while the separation efficiency as a function of liquid composition do not change appreciably, the location of the azeotrope does. This confirms that pressure-swing distillation is a feasible alternative while high-pressure distillation, although feasible, will probably require high-energy consumption. The binary phase diagrams do not show any miscibility gaps (absence of VLE points on the phase diagram is not found). Therefore, distillation followed by decanter is also eliminated as an alternative. The reduced superstructure at the end of step 4.D is shown in figure 5.10 (the grayed lines indicate the eliminated alternatives). Table 5.9(a) lists the

corresponding binary variable values.

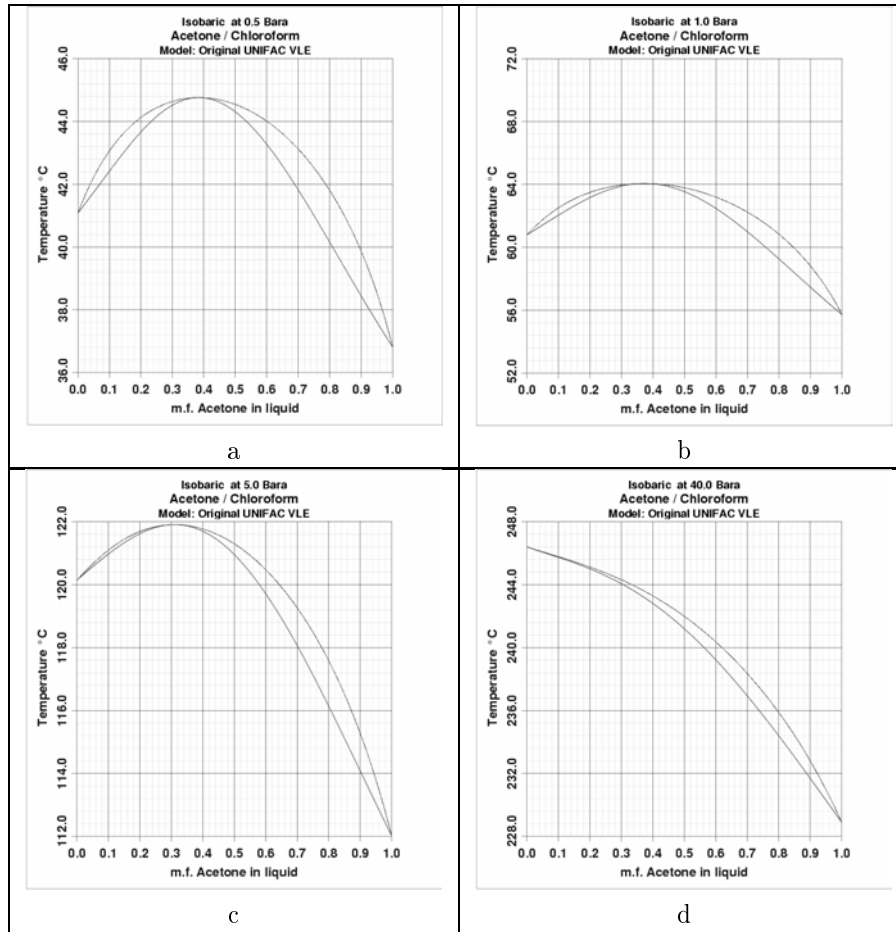

Figure 5.9: T-xy diagrams for the system acetone-chloroform at 0.5, 1.0, 5.0 and 40 Bar.

In step 4.E, the solvent alternatives are generated, this can be done using the ProCAMD tool available in ICAS (described in section 2.4.1.1). The design criteria have been to search for acyclic alcohols, aldehydes, ketones, acids, ethers, and esters with the property constraints given below.

$$\overline{g_2}(x) : \begin{cases} 340K \leq T_{boil} \leq 420K \\ \beta \geq 3.5 \\ S_p \geq 2.0 \\ S_l \leq 0.9 \end{cases} \quad (5.3)$$

$$\overline{h_3}(x) : \begin{cases} \text{No azeotrope with either acetone or chloroform} \\ \text{Feed: Acetone 34.4 mole\%, Chloroform 65.6 mole\%} \end{cases} \quad (5.4)$$

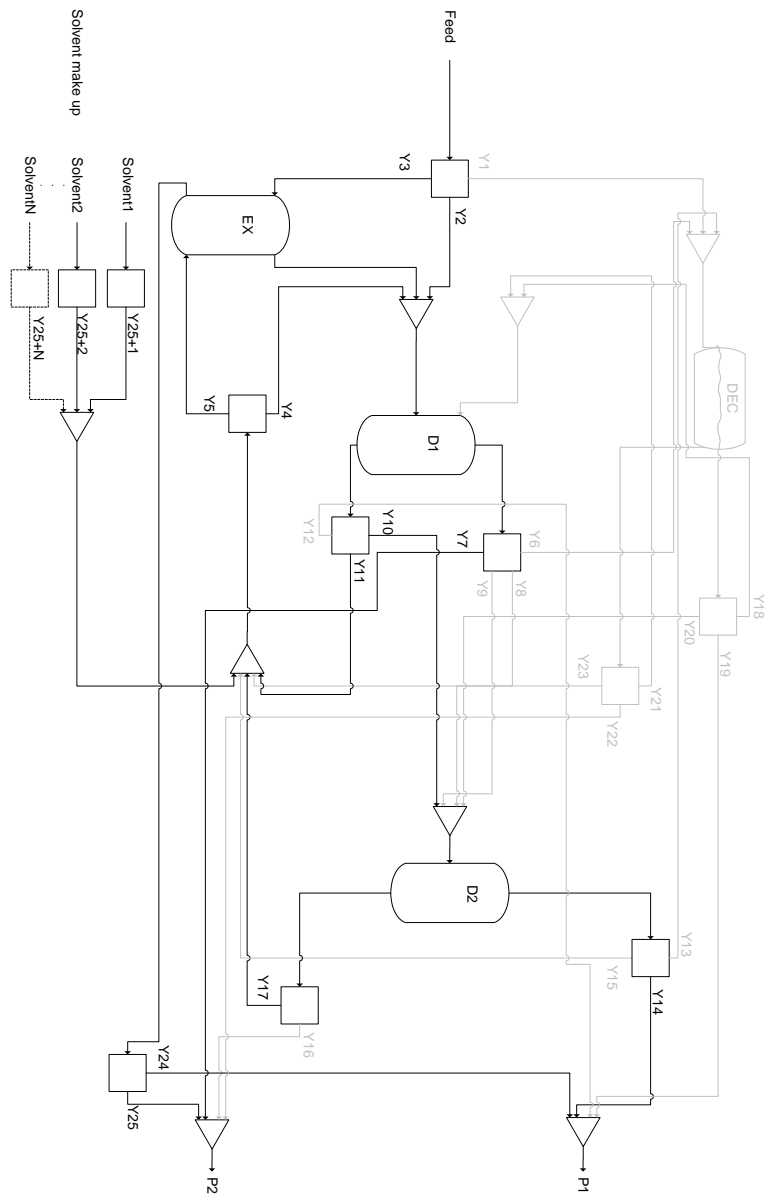

Figure 5.10: Reduced superstructure after step 4.D.

	y_1	y_2	y_3	y_4	y_5	y_6	y_7	y_8	y_9	y_{10}	y_{11}	y_{12}	y_{13}	y_{14}	y_{15}	y_{16}	y_{17}	y_{18}	y_{19}	y_{20}	y_{21}	y_{22}	y_{23}	y_{24}	y_{25}	
D	1						1					1														
E	1		1					1			1			1	1											
F	1		1				1		1				1				1									
H		1		1			1				1														1	

(a)

	y_1	y_2	y_3	y_4	y_5	y_6	y_7	y_8	y_9	y_{10}	y_{11}	y_{12}	y_{13}	y_{14}	y_{15}	y_{16}	y_{17}	y_{18}	y_{19}	y_{20}	y_{21}	y_{22}	y_{23}	y_{24}	y_{25}
D	1						1					1													
F	1		1				1				1			1			1								

(b)

Table 5.9: Separation superstructure (a) semi reduced (b) final

- | | | | |
|---|--|---|---|
| D | Pressure swing distillation (high boiling azeotrope) | E | Extractive distillation (low boiling azeotrope) |
| F | Extractive distillation (high boiling azeotrope) | H | Liquid - Liquid extraction + distillation (no azeotrope in extract) |

y_i is the selection variables in the generic superstructure shown in figures 5.10 and 5.14.

The solvent related properties β , S_p and S_l are calculated using the following equations:

$$S_l = \frac{1}{\gamma_{S,B}^{\infty}} \quad (5.5)$$

$$\beta = \frac{\gamma_{B,S}^{\infty}}{\gamma_{A,S}^{\infty}} \quad (5.6)$$

$$S_p = \frac{1}{\gamma_{A,S}^{\infty}} \quad (5.7)$$

In Eqs. 5.5-5.7, the group contribution based UNIFAC method (Fredenslund *et al.*, 1977) has been used to estimate the $\gamma_{i,j}^{\infty}$ values. The use of $\overline{g_2}(x)$ and $\overline{h_3}(x)$ refers to the equations being part of the type of formulation given by equations 3.1 - 3.7. The numerical values of the design specifications for the solvent related properties could be chosen freely. In order for a solvent to be attractive it should have a high selectivity and solvent power and a low solvent loss. In this case the specifications are set to the above values in order to screen out the least desirable candidates. Note that by only considering acyclic molecules containing carbon, hydrogen and oxygen an implicit environmental consideration has been satisfied by avoiding aromatic substances and compounds containing halogens. A summary of the CAMD results is given in figure 5.11. In this case two generation levels were used. The first level generated group vectors while the second combined the groups in the group vectors to form molecular structures (compounds). "Solution statistics" gives information of the number of group vectors and compounds designed in each level and how many were selected. The final result from the CAMD program is in this case 23 compounds fulfilling all the specifications (see appendix G). Results from the screening operations are given for each level indicating which specification caused an alternative to be rejected. Note that in order to use the CAMD results in step 4.F and later on in solving the optimization problem, it is necessary to first determine which of the feasible solvent alternatives can be considered, although, all feasible alternatives are eligible. However, since the environmental constraints need to be checked (through a database), some may be eliminated at this stage. Also, from a process simulation point of view, some of the generated feasible solvent alternatives may not have the necessary property values needed by the process model. Therefore, even though a potentially optimal solvent may be eliminated, unless all necessary property values are available for a generated feasible solvent, they are not considered in the later steps.

After identifying the CAS-NO (if possible) for the designed compounds and validating the estimated properties, the following solvents were selected using the selection criteria of *Solvent power * Selectivity*:

1-hexanal (66-25-1)
 amyl methyl ether (628-80-8)

<u>Solution statistics:</u>	
Number of group vectors designed: 47792;	Number of group vectors selected: 53
Number of compounds designed: 528;	Number of compounds selected: 23
Total time used to design: 57.01 s	
<u>'Screened Out' Statistics for Level 1:</u>	
Functional group screening: 46990 of 47792;	T _{boil} : 472 of 802
Solvent loss: 5 of 330;	Solvent power: 198 of 325
Selectivity: 64 of 127;	Azeotrop calculation: 10 of 63
<u>'Screened Out' Statistics for Level 2:</u>	
T _{boil} : 481 of 528;	Solvent power: 23 of 47
Azeotrope calculation: 1 of 24	

Figure 5.11: Solve summary solvent design problem.

Note that amyl methyl ether is also known as methyl-n-pentyl-ether. Examination of the available EH&S data for the two selected compounds in the EH&S databases reveals that 1-hexanal is not classified as carcinogenic or tumorigenic (Silver Platter Information Inc., 1998c) while limited data is available for amyl methyl ether. The lack of classification data for amyl methyl ether is not cause for exclusion of it from the candidate list but indicates that additional exploration of literature is needed before selecting it as the optimal solvent. Note that if the selection criteria is changed, a new set of compounds may be selected from the basic set of feasible solvent alternatives generated in step 4.E. More solvent alternatives could also have been selected, however, for purposes of illustration, two alternatives plus benzene is sufficient.

In step 4.F, ternary mixture property based analysis is performed. As in the case of benzene, these two solvents also form homogeneous systems with the acetone-chloroform binary mixture. Figures 5.12a and 5.12b show the solvent-free phase diagrams for the acetone-chloroform system with amyl methyl ether and 1-hexanal as solvents, respectively. These phase-diagrams help to identify the solvent to feed ratio (corresponding to high separation efficiency). Figures 5.13a and 5.13b show the ternary phase diagrams for the same ternary systems. The separation boundaries and the location of binary azeotropes can be noted in these figures. These diagrams are used together with column design algorithm (section 3.3.3.1) to generate estimates for column design specifications.

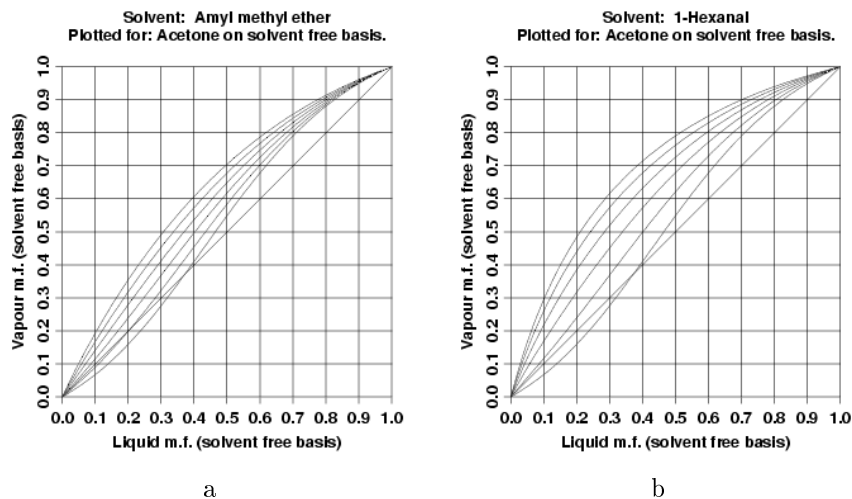

Figure 5.12: VLE diagram (solvent free basis).

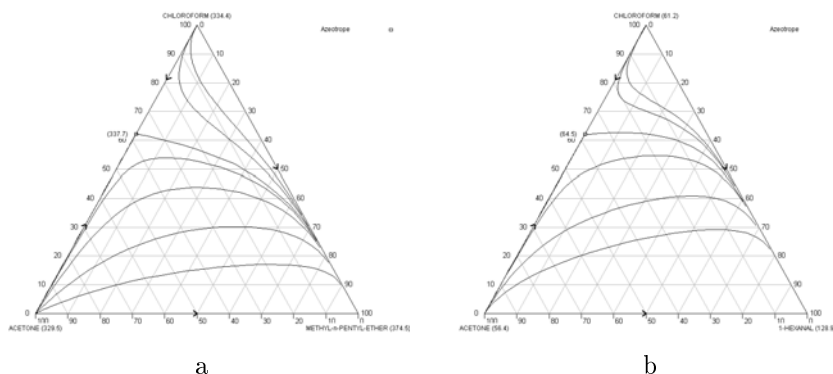

Figure 5.13: Residue curve maps for the selected solvents.

Since the solvent alternatives from step 4.E only refer to homogeneous systems, liquid-liquid extraction and azeotropic distillation as separation alternatives are also eliminated from the reduced superstructure of figure 5.10. Finally, since carbon dioxide has been found to have low solubility in acetone and poor selectivity (in relation to chloroform), super-critical extraction is also eliminated as an alternative from the reduced superstructure of figure 5.10. At the end of step 4.F, the final reduced superstructure is shown in figure 5.14. Table 5.9(b) lists the corresponding binary variables which have non-zero values.

After steps 1-4, the optimization problem corresponding to the final reduced superstructure is ready to be solved. The flowsheet alternatives are extractive distillation with solvent recovery and pressure swing distillation. Extractive distillation has three alternatives, that is, three solvent alternatives. Note that all alternatives require a two distillation columns configuration. The three solvent alternatives are, benzene, 1-hexanal and methyl-n-pentyl ether. Benzene

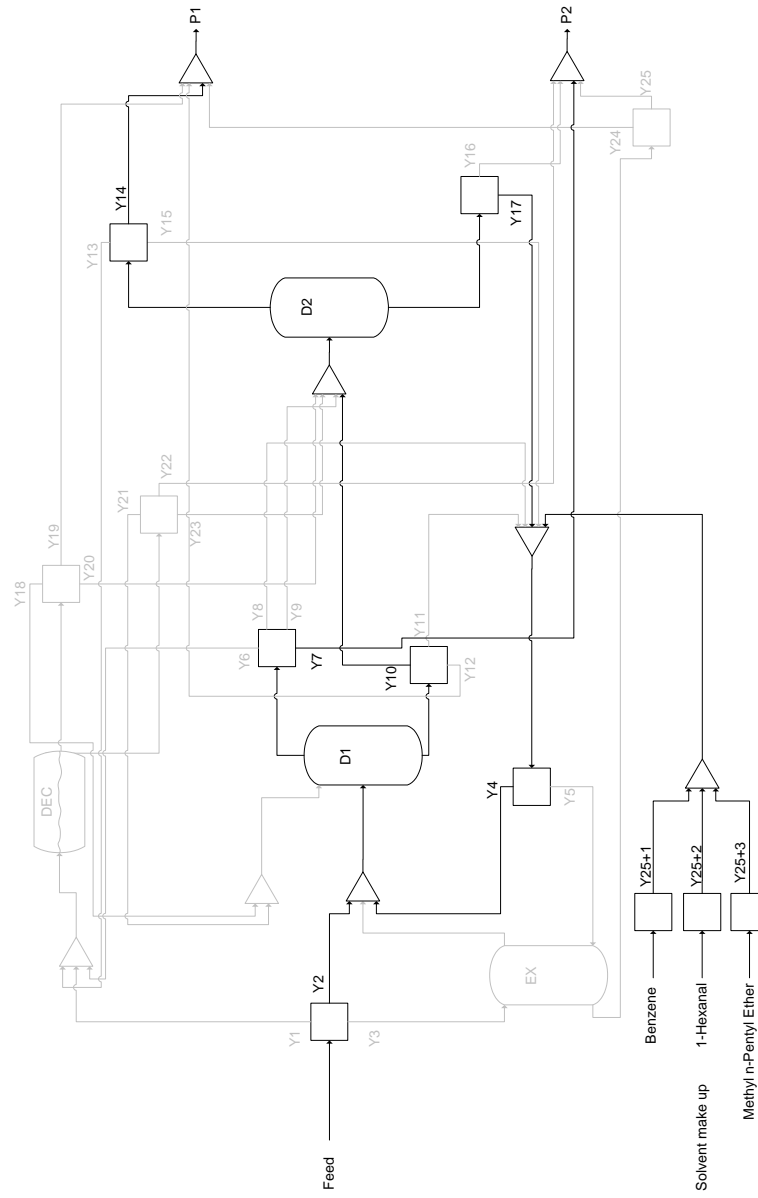

Figure 5.1.4: Reduced superstructure after step 4.D.

is included in order to compare its performance with the other alternatives even though the environmental constraints for benzene are not satisfied. The optimization problem is described below.

$$\begin{aligned}
 F_{OBJ} &= \max \{C^T \mathbf{y} + f(\mathbf{x})\} & (5.8) \\
 &= \max \left\{ \sum_p C_p * F_p - \sum_s y_{25+s} * C_s * F_s - C_{elec} * Q_{pump} \right. \\
 &\quad \left. - C_{steam} * \left(\sum_i Q_{bi} + Q_{hex} \right) - C_{cooling} * \sum_i Q_{ci} \right\}
 \end{aligned}$$

s.t.

$$\overline{h}_1(x) : \begin{cases} \text{Pressure in column 1} = \begin{cases} 1 \text{ atm. if extractive distillation} \\ 10 \text{ atm. if pressure swing distillation} \end{cases} \\ \text{Outlet pressure of pump} = \text{Pressure in column 1} \\ \text{Feed} = 5 \text{ kmole/hr Acetone} + 5 \text{ kmole/hr Chloroform} \end{cases}$$

$$\overline{h}_2(x) : \begin{cases} \text{Mass \& Energy balance for mixer} \\ \text{Energy balance for pump} \\ \text{Energy balance for heat exchangers} \\ \text{Mass \& Energy balance for column 1 \& 2} \\ \text{Total Mass \& Energy balance for flowsheet} \end{cases}$$

$$\overline{g}_1(x) : \begin{cases} \text{Molefraction of acetone in distillate in column 1} \geq 0.99 \\ \text{Recovery of acetone in column 1} \geq 99\% \\ \text{Molefraction of chloroform in distillate in column 2} \geq 0.98 \\ \text{Recovery of chloroform in column 2} \geq 90\% \end{cases}$$

where

$$\begin{aligned}
 \mathbf{x} &= [T_{F,C1}, P_{TP,C1}, P_{TP,C2}, F_S] \\
 \mathbf{y} &= [y_2, y_4, y_7, y_{10}, y_{14}, y_{17}, y_{26}, y_{27}, y_{28}]
 \end{aligned}$$

Equation 3.5 reduces to:

$$0 \leq \mathbf{B} \mathbf{y} \leq 1, \quad \text{where } \mathbf{B} = [0, 0, 0, 0, 0, 0, 1, 1, 1]$$

In the above objective function, the vector \mathbf{x} includes feed temperature for column 1, top plate pressures in columns 1 and 2 and flowrate of solvent make-up for the three solvent alternatives related to extractive distillation. Energy integration has not been considered for pressure swing distillation or extractive distillation. The objective function maximizes a profit function where the costs of operation and solvent are considered.

The solver used is the "interactive MINLP solver" (described in section 3.3.5). Due to the small number of flowsheet alternatives, the solution of the MILP master problem is simplified (also described in section 3.3.5). The solution summary is shown in Table 5.10, the outer-loop was started with extractive distillation using benzene as the solvent ($\mathbf{y} = [y_2, y_4, y_7, y_{10}, y_{14}, y_{17}, y_{26}]$). At the optimal NLP solution, the three feasible set of binary variables were evaluated. The objective function values point to extractive distillation with methyl-n-pentyl ether as the solvent for the next inner-loop iteration. At optimal NLP solution (the objective function is larger than that with benzene as the solvent), the remaining feasible sets of binary variables are evaluated. The two alternatives do not give larger values of the objective function. Also, the optimal NLP solutions for these two alternatives are smaller than that of methyl-n-pentyl ether. Therefore, the optimal solution is the one obtained after iteration 1.

Since pressure-swing distillation flowsheet in the superstructure of figure 5.14 actually does not include heat integration, it is not the optimal flowsheet. If, through heat integration, more than 25 % of the required energy can be saved (or recovered), then pressure-swing distillation will become the optimal flowsheet. Since heat integration may involve the use of streams from other parts of the process, its inclusion is outside the scope of the present problem formulation. In this case, heat integration of the entire process needs to be investigated and not just part of the flowsheet as in the present problem formulation. It should also be noted that selection of other criteria in step 4.E may lead to a different solution as also inclusion of additional objectives in the objective function. Finally, this problem formulation has attempted to satisfy the environmental constraints not to minimize the environmental impact. It may be possible to obtain another solution if the environmental impact is also minimized in addition to satisfying the environmental constraints.

5.5 Methanol synthesis

Methanol is one of the most important raw materials in chemical processes, both as a starting material as well as a solvent. The main source for production of methanol is natural gas (Methane) which is reformed with steam to 'synthesis gas', a mixture of carbon monoxide, carbon dioxide and hydrogen.

This example highlights the idea of integration in the integrated process synthesis framework. While the previous examples focused on specific features in more detail, this example highlights the integration aspects. For this purpose the methanol process with synthesis gas as the starting point has been selected. The integrated framework as described in chapter 4, starts with the pre-analysis phase where the problem is formulated in general terms and existing knowledge is found from databases and/or literature survey.

Iteration	Binary variables	NLP-solution	F_{OBJ}
1. Inner	$y_2, y_4, y_7, y_{10}, y_{14}, y_{17}, y_{26}$ (Extractive, benzene)	$T_{FC1} = 343$ K $P_{TP,C1} = 101$ kPa $P_{TP,C2} = 198$ kPa $F_s = 0.0925$ kmole/hr	114.9 \$/hr
1. Outer	$y_2, y_4, y_7, y_{10}, y_{14}, y_{17}, y_{27}$ (Extractive, 1-hexanal)	Evaluation	82.8 \$/hr
	$y_2, y_4, y_7, y_{10}, y_{14}, y_{17}, y_{28}$ (Extractive, methyl-n-pentyl ether)		119.6 \$/hr
	$y_2, y_4, y_7, y_{10}, y_{14}, y_{17}$ (Pressure swing)		47.1 \$/hr
2. Inner	$y_2, y_4, y_7, y_{10}, y_{14}, y_{17}, y_{28}$ (Extractive, methyl-n-pentyl ether)	$T_{FC1} = 338$ K $P_{TP,C1} = 101$ kPa $P_{TP,C2} = 31.9$ kPa $F_s = 0.0346$ kmole/hr	134.7 \$/hr
NLP evaluation	$y_2, y_4, y_7, y_{10}, y_{14}, y_{17}$ (Pressure swing)	$T_{FC1} = 270$ K $P_{TP,C1} = 101.3$ kPa $P_{TP,C2} = 49.8$ kPa $F_s = \text{n.a.}$	90.03 \$/hr

Table 5.10: Optimization results using the interactive MINLP-algorithm

5.5.1 Pre-analysis phase

The problem treated in this example can be formulated as:

Using the integrated process synthesis framework, determine the preliminary process design for a process capable of producing approximately 150 tons of methanol per year having synthesis gas as the raw material.

Synthesis gas is characterized by its stoichiometric relationship among the gases it consists of, and in order for the synthesis gas to be suitable for methanol production hydrogen must be in sufficient excess (Fiedler *et al.*, 1990). The composition of the synthesis gas used in this example is given in Table 5.11. Three gas phase reactions are involved when methanol is produced from synthesis gas:

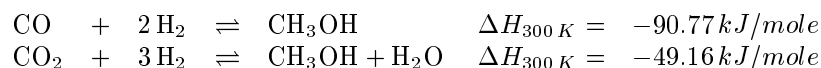

Water gas-shift reaction:

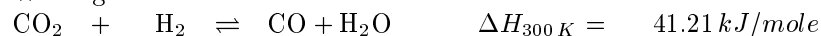

Due to the importance of the process reflected by the high volumes of methanol being produced (in 1989 the production was approximately $21 \cdot 10^6$ tons, Fiedler *et al.* (1990)), the methanol synthesis process has been subject of numerous studies and publications. Especially in the reactions area, both when it comes to deriving kinetic expressions for the reactions as well as in reactor design and subsequent separations.

5.5.1.1 Reaction kinetics

When determining a preliminary process design where reactions must be considered, it is important to have good expressions for the reaction kinetics, meaning that they should model the kinetics accurately without unnecessarily complex correlations. The reactions take place in a catalytic environment and since the 1960s when ICI introduced the highly selective copper oxide catalysts, which allowed for lower operating pressures, the conditions of operation being for the pressure 5-10 MPa and 200-300 °C for the temperature. While many authors have published expressions for the reaction kinetics only a few of them published the experimental data used to derive these expressions. One good

	Mole fraction
Carbon Monoxide	0.10
Carbon Dioxide	0.15
Hydrogene	0.75

Table 5.11: Composition of synthesis gas for methanol production.

source for data is the equilibrium and kinetic studies by Graaf *et al.* (1986, 1988).

Many authors have suggested that catalyst inhibition terms need to be included in the kinetic expressions. Such terms, however, makes the expressions more complicated and 'heavier' from a computational point of view. Therefore, the reaction analysis tool (section 3.3.1) was employed in order to see if standard mass action expressions could fit the data of Graaf *et al.* (1988). The reaction rate expressions is used in the estimation were:

$$\begin{aligned} r_{CH_3OH,1} &= k_1 \cdot p_{H_2}^2 \cdot p_{CO} \\ r_{CH_3OH,-1} &= k_{-1} \cdot p_{CH_3OH} \\ r_{CH_3OH,2} &= k_2 \cdot p_{H_2}^3 \cdot p_{CO_2} \\ r_{CH_3OH,-2} &= k_{-2} \cdot p_{CH_3OH} \cdot p_{H_2O} \\ r_{H_2O,3} &= k_3 \cdot p_{H_2} \cdot p_{CO_2} \\ r_{H_2O,-3} &= k_{-3} \cdot p_{H_2O} \cdot p_{CO} \end{aligned}$$

where,

$$k_i = A_i \cdot \exp\left(\frac{-E_i}{T}\right)$$

All the pre-exponential factors and activation energies were estimated. With the values estimated by the tool it was possible to match partial pressures of the reactants quite well. However, as can be seen from the parity plots in figure 5.15 for the products (methanol and water), these are scattered and the difference in measured vs. calculated partial pressure are sometimes as large as 90 %. It was therefore decided to use expressions with catalyst inhibition terms instead, and to see such suitable expressions could be found in the literature.

In the work of Šeltinc and Levec (1999) a number of expressions were compared and it was concluded that the models with the widest application ranges are the either the expressions proposed by Bussche and Froment (1996) or those proposed by Graaf *et al.* (1988). Bussche and Froment (1996) assumed (from earlier studies) that CO_2 was the main carbon source in methanol, and therefore, only two kinetic expressions were needed. One for methanol formation and one for formation of water. The expressions they proposed, after some algebraic manipulations, are given by:

$$\begin{aligned} r_{CH_3OH} &= \frac{K_{N1} p_{CO_2} p_{H_2}^4 - K_{N-1} p_{H_2O} p_{CH_3OH} p_{H_2}}{(p_{H_2} + K_{D1} p_{H_2O} + K_{D2} p_{H_2}^{3/2} + K_{D3} p_{H_2O} p_{H_2})^3} \\ r_{H_2O} &= \frac{K_{N2} p_{CO_2} p_{H_2} - K_{N-2} p_{H_2O} p_{CO}}{(p_{H_2} + K_{D1} p_{H_2O} + K_{D2} p_{H_2}^{3/2} + K_{D3} p_{H_2O} p_{H_2})} \end{aligned}$$

where,

$$K_X = A_X \cdot \exp\left(\frac{-E_X}{RT}\right) \quad ; \quad R = 8.314 \cdot 10^{-3} kJ/mol/K$$

with the following parameters:

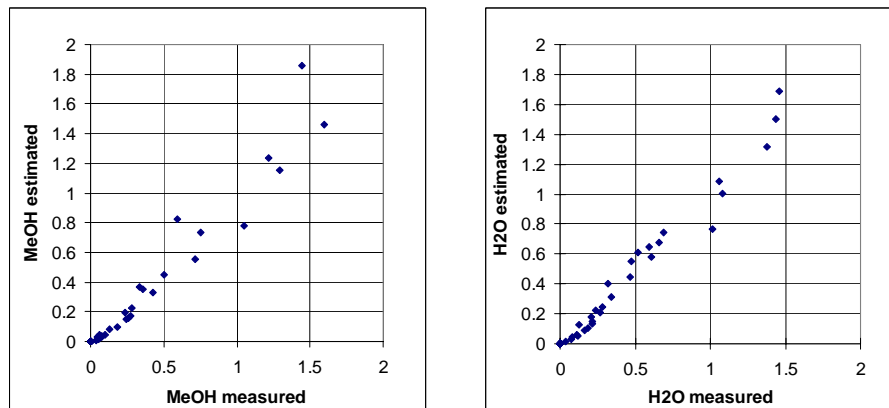

Figure 5.15: Parity plots (measured vs. calculated partial pressures) for methanol and water.

X	A	E
N1	1.07 $mol/(kg_{cat}\cdot s)$	-36.696 kJ/mol
N-1	$4.182 \cdot 10^{10}$ $mol/(kg_{cat}\cdot s)$	21.999 kJ/mol
N2	$1.22 \cdot 10^{10}$ $mol/(kg_{cat}\cdot s)$	94.765 kJ/mol
N-2	$1.141 \cdot 10^8$ $mol/(kg_{cat}\cdot s)$	55.08 kJ/mol
D1	3453.38	
D2	0.499	17.197 kJ/mol
D3	$6.62 \cdot 10^{-11}$	124.119 kJ/mol

These expressions were implemented in the ICAS steady state simulation engine (ICASSim). Then a simple flowsheet with a CSTR was used to check if the experimental data from Graaf *et al.* (1988) could be matched. At least for the tested data ranges this was case – difference in measured vs. calculated partial pressures was less than 20 %. Table 5.12 shows a comparison between experimental data from Graaf *et al.* (1988) and calculated values with the equations from Bussche and Froment (1996), at the conditions of 483.5 K and 50.8 bar.

Even though, both light and heavy (compared to methanol) by-products are formed, reactions for these were not included. With copper oxide catalysts,

	CO	CO ₂	H ₂	CH ₃ OH	H ₂ O
Input [molef]	0.065	0.261	0.674	0	0
Output,exp [molef]	0.0666	0.2542	0.6573	0.0117	0.0102
Output,calc [molef]	0.0677	0.2541	0.6530	0.0131	0.0121
(calc-exp)/exp [%]	1.72	-0.05	-0.66	11.80	18.95

Table 5.12: Exaperimental vs. calculated values.

which are highly selective ($> 99.5\%$ according to Fiedler *et al.* (1990)), the formation of by-products are low. Among typical light by-products are dimethyl ether and heavy ones are higher alcohols, esters, acids and hydrocarbons. In order to make the remaining part of this example more realistic, the following by-products are introduced after the reactor :

- Light: Dimethyl ether
- Heavy: 1-Hexanol

Another important issue is the design of the reactor, since the methanol formation is an exothermic reaction, heat has to be removed from the reactor. Both adiabatic and isothermal reactors are being applied in existing production plants. It is outside the scope of this example, however, to model the highly sophisticated operations that are employed in some of these designs.

At this point, information (mainly on reactions) has been gathered through the 'integrated framework', and this information can now easily be applied in the remaining phases – flowsheet generation and solution.

5.5.2 Flowsheet generation phase

A detailed 'walk through' of the flowsheet and superstructure generation algorithm will not be given here (since these were given for earlier examples). Rather, it is shown how the integrated process synthesis framework may be used to generate a flowsheet and its design specifications. As stated above, detailed reactor modeling is not the focus of this example. Therefore it was decided to model the reactor as an isothermal CSTR with 42 kg of catalyst (based on simple scale up of the experiments by Graaf *et al.* (1988)). Steady state simulation of the reactor was performed, thereby the composition of the reactor outlet became known. At this point the by-products are introduced (as discussed above). Now, with the mixed reactor outlet and by-product stream, the steps of the hybrid synthesis algorithm for generating the separation flowsheet is initiated. The algorithm described in section 3.3.2 is applied and as a result the first separation technique to be placed in the flowsheet is a flash separation, with the carbon dioxide / dimethyl ether split as the separation task. Also the algorithm suggests that the vapor stream from the flash can be recycled with a purge option. Further application of the algorithm to the liquid stream, leads to the introduction of one column for the removal of lights (dimethyl ether) and a second column where methanol is the top product. The flowsheet generated is shown in figure 5.16 and the next step is to derive the design specifications. For the first flash operation, the utility calculations of ICAS (see section 3.3.4) is employed to find an appropriate operating temperature and pressure. If the operating pressure of the flash is set to the pressure for the reactor outlet (50 bar) then using the utility calculations an appropriate temperature (where only the gases to be recycled are vaporized) can be found.

Following this procedure a temperature of 250 K was found. At this point it is noted that the temperature is not necessarily the optimal – also considering the recycle of reactants. The purge fraction for the recycle is found by trial-and-error, simulating the flowsheet without the distillation columns. Finally, the specifications for the two distillation columns must be found and here the equilibrium based design algorithm is used (section 3.3.3.1). A summary of the specifications and obtained output from the algorithm for the two columns are shown in Table 5.13. Additional results from the algorithm are estimates on plate temperature and compositions. Here the full advantage of the integration is obvious, since all these numbers are transferred back to the framework on request without any further user interaction.

5.5.3 Simulation and optimization

The flowsheet generated above now has all the specifications needed in order to do a simulation, and through ICAS (the driver for the integrated framework for process synthesis) all the values are passed to the simulator. Due to initialization with estimates from equilibrium based column design algorithm, the steady state simulation converges very fast, which can be seen from the simulation time given along with the stream summary in appendix H. As a final step, an optimization problem is set up in ICAS. The design variables considered

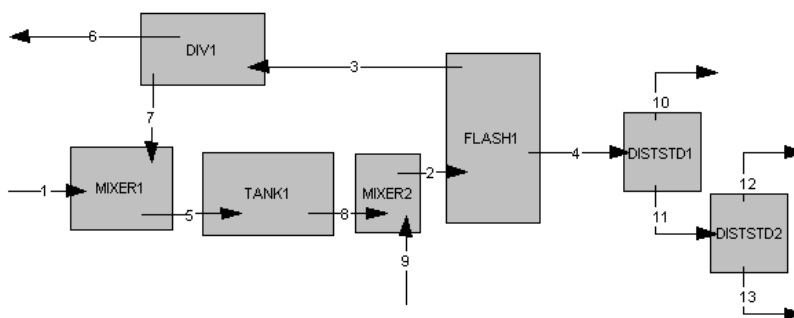

Figure 5.16: Flowsheet generated for methanol production.

Col.	Specification	Reflux	Overall recovery in top product	Stages	Feed stage
1	< 0.001 mole% of heavys in top	3	0.047	6	5
2	< 0.005 mole% of heavys in top	14	0.6	13	10

Table 5.13: Design details for the two distillation columns (number of plates and feed stage).

here are the overall recovery and reflux ratios in the distillation columns. Note that the distillation design algorithm generates values for overall recovery in the bottoms and reflux ratio in the top. Thereby the design algorithm does not guarantee that the product specifications entered into the design algorithm are matched exactly, only that they will be close. However, in the formulation of the optimization problem, such requirements on purities can easily be met, by specifying these as constraints. Here the purity of methanol in the product is constrained to be higher than 99 mole%, and in the object function (given by equation 5.9) profit is maximized. In Table 5.14 the costs used for the objective function is listed. Heat integration was not considered in the optimization problem, although it is a very important part of the actual process. Table 5.15 lists the optimal values for the design variables, and the value of the objective function at the optimal solution is 1.42 MU/hr.

$$F_{OBJ} = \max \{ C_{Methanol} * F_{Methanol} - C_{Synthesis\ gas} * F_{Synthesis\ gas} - C_{heating} * (Q_{reb.D1} + Q_{reb.D2}) - C_{cooling} * (Q_{cond.D1} + Q_{cond.D2}) \} \quad (5.9)$$

Methanol	4.835	MU/kmole
Synthesis gas	1.246	MU/kmole
$C_{heating}$	8.0e-6	MU/kJ
$C_{cooling}$	0.7e-6	MU/kJ

Table 5.14: Costs used in the objective function. MU - monetary unit

	Lower	Level	Upper
Reflux ratio, D1	1.5000	1.5000	10.0000
Bottom recovery, D1	10.9000	0.9495	1.0000
Reflux ratio, D2	2.0000	3.7111	20.0000
Bottom recovery, D2	10.3000	0.3934	0.7000

Table 5.15: Optimal values for design values.

CONCLUSIONS

6.1 Achievements

The main achievement of this work is the development of the integrated process synthesis framework – a computational environment that facilitates the dataflow among algorithms and tools for process synthesis and design. The motivation for the idea of integration is a reduction of time spent in formulating and solving preliminary process design tasks, thereby allowing for quicker evaluation of potential projects and reduction of time-to-market. The framework has three phases (pre-analysis; flowsheet and superstructure generation; and optimization and evaluation) and is driven through user-interaction. Among the tools that benefit in particular from the integration, compared with the present state of the art, is:

- The equilibrium based algorithm for design of distillation column, where through the integration, the results from this algorithm can be used to initialize steady state simulations, thereby ensuring fast and easy convergence.
- The hybrid synthesis approach, where through the integrated framework, a flowsheet or superstructure is generated and then solved with the 'interactive MINLP solver'

The framework also draws attention to the importance of steps that are preceding before an optimization problem can be solved. While a lot of research in the area of process synthesis during the last decades have focused on optimization it has been neglected that often the problem formulation steps are the most time consuming. Furthermore, what many researchers do not realize is that the usability of any algorithm can be enhanced significantly when the right framework is available – with easy data access (databases) and good connection with rest of the framework (open environment).

The second achievement is the development of the hybrid synthesis approach. The hybrid approach proposed in this thesis enables a systematic analysis of the process synthesis problem (analysis and flowsheet generation for the reaction and separation blocks) prior to the solution of the problem. Consequently, reduction of complexity and size of the general mathematical problem without introduction of unnecessary (or unrealistic) simplifying assumptions that may

incorrectly eliminate candidate alternatives becomes feasible. After the analysis step, the hybrid method provides an interactive solution strategy for the reduced mathematical problem formulation. This solution strategy is based on the decoupling of the MINLP problem into a NLP sub-problem and a MILP master-problem. By incorporating a process simulator with NLP optimization feature in the inner-loop (NLP sub-problem), it is possible to employ rigorous process models. In the outer-loop (MILP master-problem), it is possible to enumerate all feasible binary variable sets or to use a MILP solver to generate the next estimate for the set of binary variables. In one of the two examples highlighting the hybrid approach, because of the significant reduction in the problem size, it was possible to enumerate all feasible sets of binary variables. This, however, is not a general case for all separation problems related to removal of a chemical species from a process stream. It is quite possible that after the analysis steps, no reduction is possible. For such cases, solution of the MILP master-problem in the outer-loop would be necessary. The interactive nature of the solution strategy of the hybrid method, however, provides some insights and control that is otherwise missing in purely mathematical solution approaches. Process design and synthesis is by nature a trial and error procedure. Consequently, an interactive solution strategy that maintains the efficiency and reliability of the original solution method while providing additional information related to the problem appears to be well suited for the class of synthesis and design problems addressed in this work.

A third significant achievement is the development of the equilibrium based algorithm for design of distillation columns. Based on specifications of feed and desired products, this algorithm, through fast calculations generates design specifications (reflux ratio, number of plates and feed plate location) as well as estimates plate temperature and composition. In this way the algorithm practically eliminates the often tedious task getting the first convergence of distillation column in simulation. Recent work has shown the results from the can easily be applied and other simulators than ICASSim.

The development of the reaction analysis tool is also an important achievement. This tool features one common environment for: Storing of various types of reaction related data; Estimation of reaction kinetics; Simulation and optimization of reactors. Due to the design of the tool, which allows for easy sharing of projects among coworkers, the tool has been used successfully in numerous projects.

It is difficult to quantify the amount of time that can be saved using the integrated framework, however the time savings are mainly due to two reasons:

- Better solution efficiency in simulations, because of the use of the generated initial estimates, and also the distillation operations always converges. Thereby the time spent on trial-and-error for simulations is decreased.
- The designer will need to spend less time in entering and passing information and also he will not need to constantly check if the information

used in consistent. Rather, he will spend the time in making decisions at the computer.

Due to these reasons the designer can spend more time away from the computer. The industrial member companies of CAPEC can confirm this, one example being the use of the reaction analysis tool another example being use of the process design tool with or without the connection to simulation and optimization. Finally, even though no examples of application of the integrated framework to pharmaceutical processes has been included under the examples, the framework have been applied to such processes. However, due to confidentiality reasons information on this could not be included.

6.2 Future work

While development of the central ideas of the 'integrated framework' have advanced significantly with this work, there are still some integration issues that needs further attention. Also, there are other classes of algorithms, which have not been used in this thesis, but which are obvious candidates for inclusion in the framework, for example:

- Algorithms for heat and mass integration. The starting point would be calculation of pinch diagrams and minimum utility loads. However, as described in the theoretical background, a number of advanced methodologies are available in this field. Adaption of such methodologies would broaden the application range for the integrated framework and make the solution procedure more effective for certain problem types.
- Methods for evaluation and minimization of the environmental impact of a process. Examples of such methods are the MEIM method by Pistikopoulos *et al.* (1994) and the WAR algorithm by Cabezas *et al.* (1999).

6.2.1 Structural optimization

In this work the 'interactive MINLP' algorithm have been used as part of the hybrid synthesis approach, but the actual algorithm was developed jointly with other coworkers of CAPEC. This interactive MINLP solver need to be further developed into an automated method for handling flowsheet alternatives. The functionality needed would be that an administrator module would be required to take care of the dataflow. The module would keep track of the flowsheet configuration that is currently active and send the necessary information to the corresponding NLP and MILP solvers.

6.2.2 Process design

The development of tools for process design has been significant especially with respect to equilibrium based distillation design. However, there are still room

for improvements:

- On the equilibrium based algorithms:
 - Improve specification facilities. For example, for ternary mixtures the product specification can be determined by marking top and bottom products in a residue curve map. Another option is determination of specifications for non key compounds by using relative volatilities.
 - The algorithm could be extended to column with multiple feeds.
- Recently there has been significant advances in the distillation design algorithm based on separation efficiency (extension to complex column etc.), these could easily be incorporated in the process design tool.
- Design algorithms for other unit operations, such as, reactors, membranes, absorbers and others are needed.

Appendices

A

**Property - separation
techniques relationship**

Table 6: Recommended values for separation feasibility indices

Separation process	P ₁	P ₂	P ₃	P ₄	P ₅	P ₆	P ₇	P ₈	P ₉	P ₁₀	P ₁₁	P ₁₂	P ₁₃	P ₁₄	P ₁₅	P ₁₆	P ₁₇	P ₁₈	P ₁₉	P ₂₀
Absorption ¹	m	-	-	-	-	-	X	X	-	-	-	-	-	-	-	-	-	-	-	-
	M	-	-	-	-	-	-	-	-	-	-	-	-	-	-	-	-	-	-	-
Azotropic distillation ¹	-	-	-	-	-	-	-	X	-	-	-	-	-	-	-	-	-	-	-	-
Cryogenic distillation ¹	m	-	-	-	-	-	-	-	-	-	-	-	-	-	-	-	-	-	-	-
	M	-	-	-	-	-	-	-	-	-	-	-	-	-	-	-	-	-	-	-
Crystallisation ¹	m	-	-	-	-	-	-	-	-	-	-	-	-	-	-	-	-	-	-	-
	M	-	-	-	-	-	-	-	-	-	-	-	-	-	-	-	-	-	-	-
Desublimation	m	-	-	-	-	-	-	-	-	-	-	-	-	-	-	-	-	-	-	-
	M	-	-	-	-	-	-	-	-	-	-	-	-	-	-	-	-	-	-	-
Distillation ¹	m	-	-	-	-	-	-	-	-	-	-	-	-	-	-	-	-	-	-	-
	M	-	-	-	-	-	-	-	-	-	-	-	-	-	-	-	-	-	-	-
Extractive distillation ^{1, 2}	m	-	-	-	-	-	X	X	-	-	-	-	-	-	-	-	-	-	-	-
	M	-	-	-	-	-	-	-	-	-	-	-	-	-	-	-	-	-	-	-
	N	-	-	-	-	-	-	-	-	-	-	-	-	-	-	-	-	-	-	-
	n	-	-	-	-	-	-	-	-	-	-	-	-	-	-	-	-	-	-	-
Flash operation ¹	m	-	-	-	-	-	-	-	-	-	-	-	-	-	-	-	-	-	-	-
	M	-	-	-	-	-	-	-	-	-	-	-	-	-	-	-	-	-	-	-
Gas separation membranes	m	1.07	-	-	-	-	-	-	-	-	-	-	-	-	-	-	-	-	-	-
	M	1.10	-	-	-	-	-	-	-	-	-	-	-	-	-	-	-	-	-	-
Ion exchange	m	-	-	-	-	-	-	-	-	-	-	-	-	-	-	-	-	-	-	-
	M	-	-	-	-	-	-	-	-	-	-	-	-	-	-	-	-	-	-	-
Leaching ¹	-	-	-	-	-	-	X	X	-	-	-	-	-	-	-	-	-	-	-	-
Liquid-liquid extraction ¹	-	-	-	-	-	-	X	X	-	-	-	-	-	-	-	-	-	-	-	-
Liquid membranes	m	-	-	-	-	-	-	-	-	-	-	-	-	-	-	-	-	-	-	-
	M	-	-	-	-	-	-	-	-	-	-	-	-	-	-	-	-	-	-	-

Figure A.1: Property - separation techniques relationship

Microfiltration	m M	-	-	-	-	-	-	-	-	-	-	-	-	-	-	-	-	-	-	-
Molecular sieve adsorption	m M	1.05 1.10	1.07 1.10	-	-	1.08 1.10	1.05 1.10	-	-	-	-	-	-	-	-	-	-	-	-	-
Partial condensation ^{2,5}	m M	-	-	-	-	-	-	-	-	-	-	1.90 2.15	-	-	-	-	-	-	-	-
Pervaporation	m M	-	-	-	1.02 1.08	-	X	-	-	-	-	-	-	-	-	-	1.00 1.01	-	-	-
Stripping ^{1, see⁶}	m M	-	-	-	-	X	X	-	-	-	-	-	-	-	-	-	0.00 1.00 1.63 3.90	-	-	-
Sublimation	m M	-	-	-	-	-	-	-	-	-	-	30.0 40.0	1.10 1.20	-	-	-	-	-	-	-
Supercritical extraction ^{1,6}	m M	-	-	-	-	X	X	X	-	-	X	-	-	-	-	-	-	-	-	X
Ultrafiltration	m M	-	-	-	-	-	-	-	-	-	-	-	-	-	-	-	-	-	-	-

¹These methods require a mass separating agent which is identified from pure component properties p_7 , p_8 and p_{22} - p_{32} and mixture properties such as selectivity, solubility. ²These separation techniques are, in addition to boiling point ratios and vapour pressure ratios, identified from pure component property values of heat of vaporisation. ³Crystallisation is identified from melting point ratios as well as pure component property values of heat of fusion at melting point. ⁴Extractive distillation is considered very feasible at a relative volatility between 1.0 and 1.5, feasible at a relative volatility between 1.5 and 2.0. At a relative volatility larger than 2.0, extractive distillation is considered infeasible since distillation is a competitive alternative. ⁵Partial condensation is also related to vapour pressure computed within T and/or P limits of correlations. ⁶In supercritical extraction the selection of the MSA is related to pure component properties p_9 , p_{10} in addition to p_7 , p_8 and p_{22} .

P₃₂

Figure A.2: Property - separation techniques relationship, continued

B

Methodology for synthesis and design of separation processes

The methodology for synthesis and design of separation processes by Jaksland (1996), have been used in this thesis. Basically the methodology consists of two different communicating levels for generation of separation process designs. Each level consists of a 6 step algorithm.

Level 1:

At level 1, mainly pure component properties are employed.

- Algorithm 1.1: Analyse mixture
- Algorithm 1.2: Compute binary ratio matrix
- Algorithm 1.3: Identify separation techniques
- Algorithm 1.4: Screen Alternatives
- Algorithm 1.5: Compute separation factors
- Algorithm 1.6: Select the first task

Level 2:

At level 2, pure component and mixture properties are employed.

- Algorithm 2.1: Indetify candidate separation task
- Algorithm 2.2: Select Mass Separating Agents
- Algorithm 2.3: Select External Agents
- Algorithm 2.4: Estimate conditions of operation
- Algorithm 2.5: Screen Alternatives
- Algorithm 2.6: Select and sequence separation task

C

Application of reaction analysis studio

The following screenshots illustrates how Reaction Analysis Studio (RAS), which was developed as part of this thesis, is used for estimating reaction kinetic parameters. The estimation problem solved is described in section 5.2.1.

The tool starts in the "Project setup" screen. Here the fundamental objects (compounds, reactions, catalyst and condition) for the project is showed, the collection of these objects makes out the "Reaction set" (see 3.3.1.1).

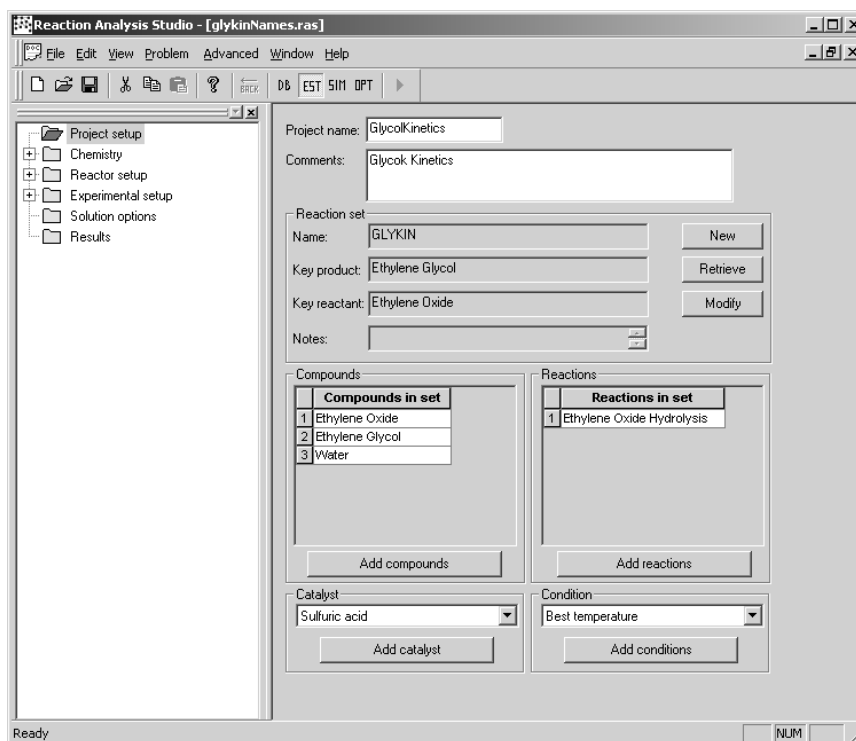

The reaction stoichiometry is defined in this screen:

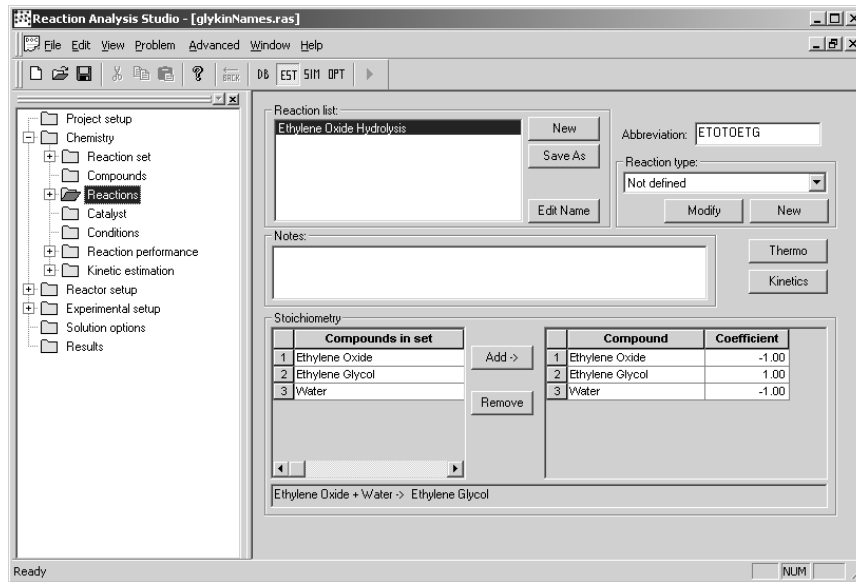

For each reaction the form of the rate expression must be defined:

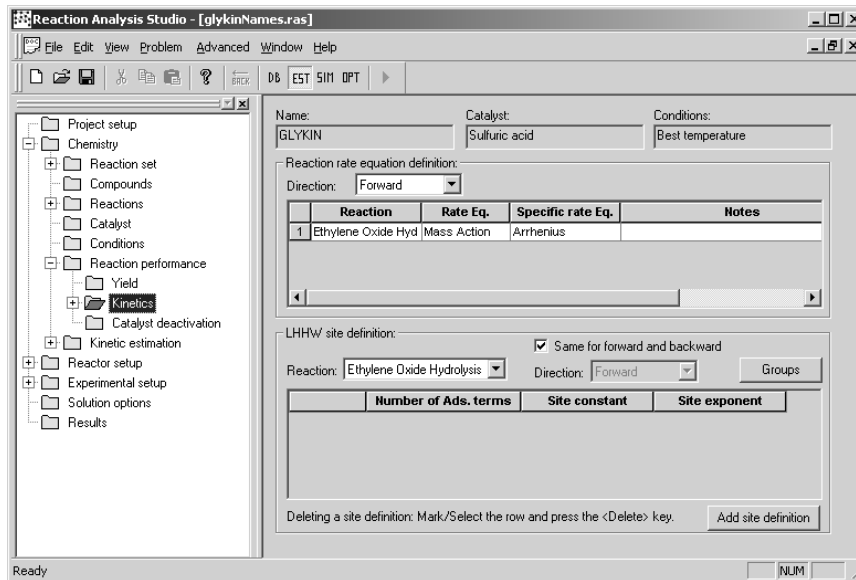

For an estimation project the parameter bounds must be specified:

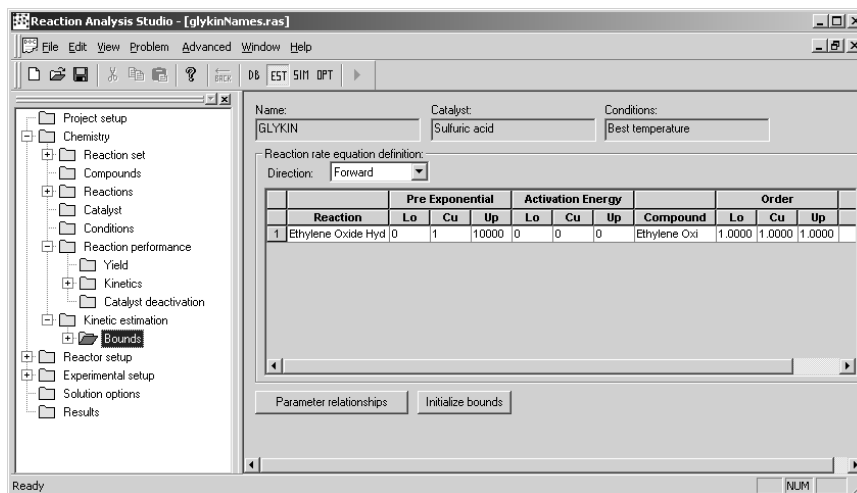

Reactor type and other details about the reactor where the experiments were conducted must be given:

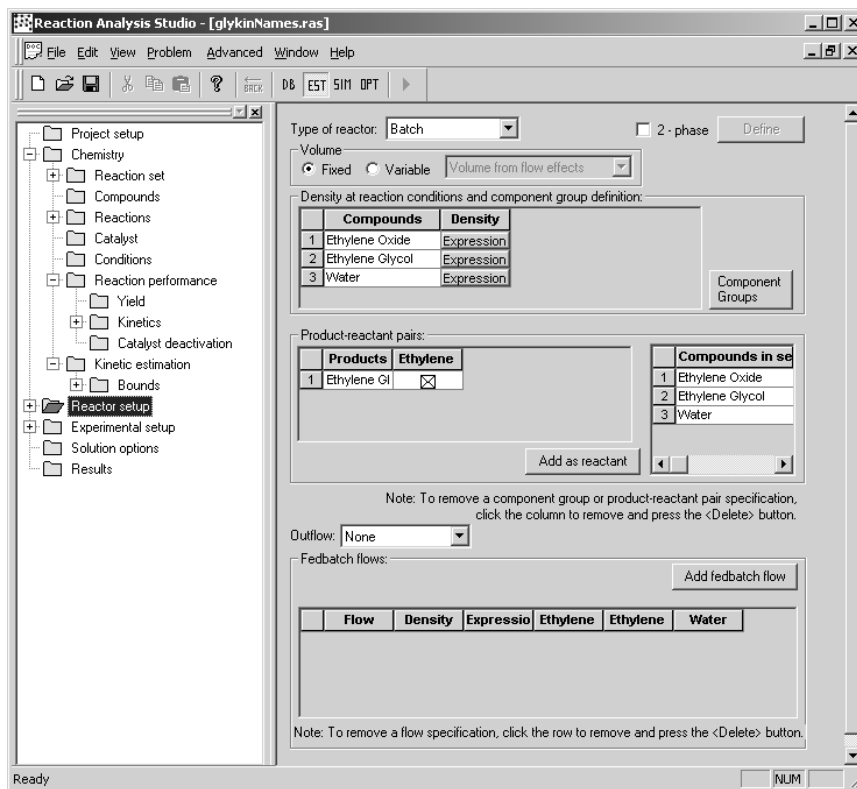

The type of data measured in the experiments and the source of the data is specified:

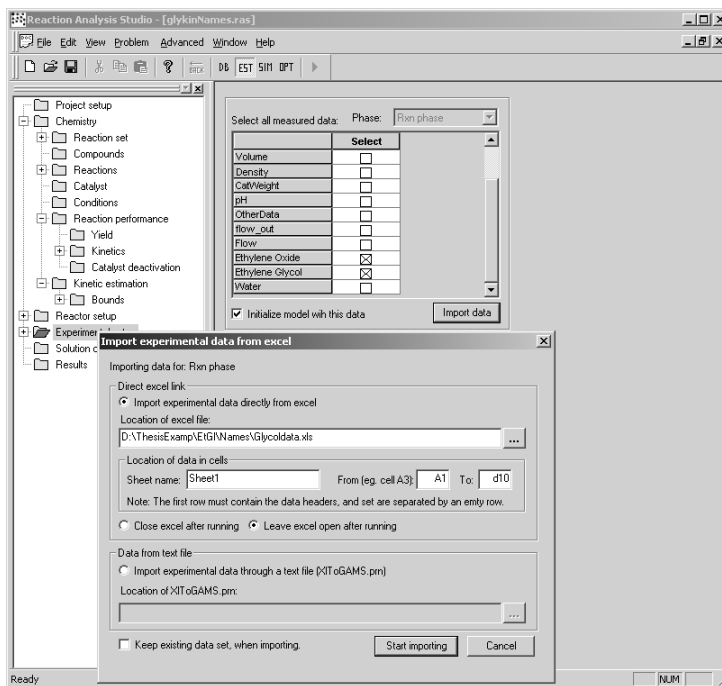

The source can simply a standard spreadsheet:

The screenshot shows a Microsoft Excel spreadsheet titled 'Microsoft Excel - Glycoldata.xls'. The spreadsheet has columns A through G. Column A contains labels 'set1.1' through 'set1.9'. Column B contains 'Time' values from 0 to 10. Column C contains 'Et-O' values from 1.000 to 0.043. Column D contains 'Et-GI' values from 0.000 to 0.957. Column E contains values from 0 to 600. Column F is empty. Column G is empty. The spreadsheet is displayed on 'Sheet1' with the 'DatatoGams' workbook.

	A	B	C	D	E	F	G
1		Time	Et-O	Et-GI			
2	set1.1	0	1.000	0.000	0		
3	set1.2	0.5	0.855	0.145	30		
4	set1.3	1	0.730	0.270	60		
5	set1.5	1.5	0.624	0.376	90		
6	set1.4	2	0.533	0.467	120		
7	set1.6	3	0.390	0.610	180		
8	set1.7	4	0.285	0.715	240		
9	set1.8	6	0.152	0.848	360		
10	set1.9	10	0.043	0.957	600		
11							
12							
13							
14							
15							

Once the data is imported weighting factors should be applied to it:

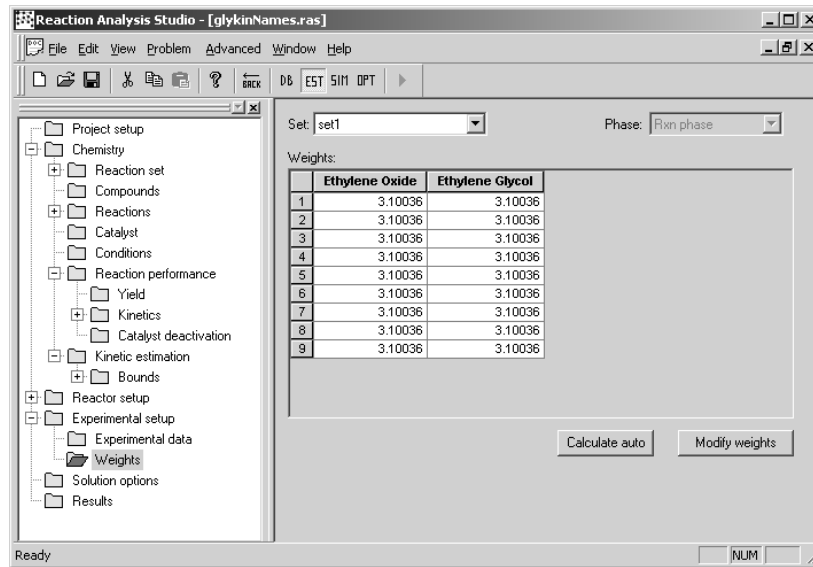

Solution options are specified:

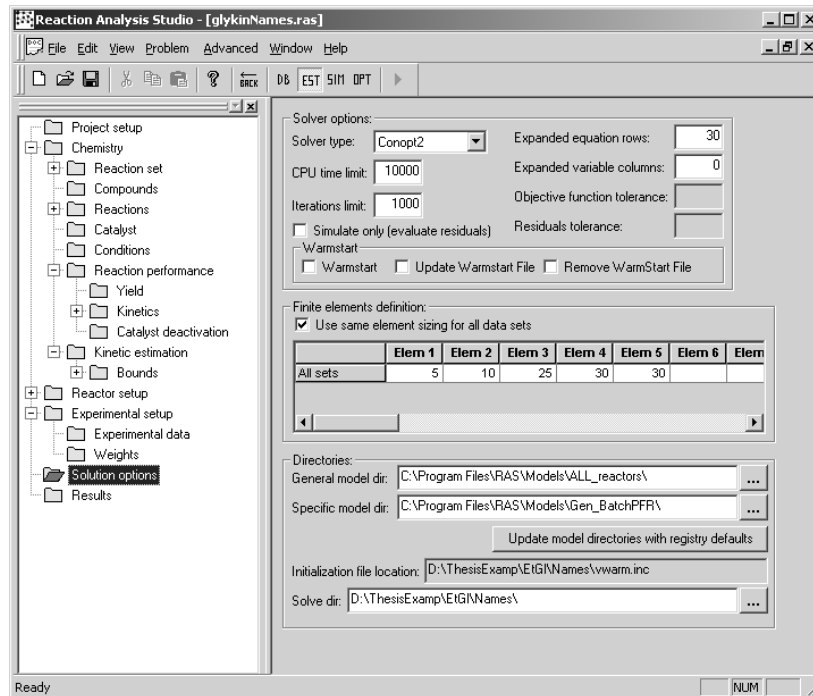

When the estimation problem is solved, the program switches to the results screen. From here the a macro-generated spreadsheet (see below) can be opened, also if the estimation was successful the parameter can imported back into RAS.

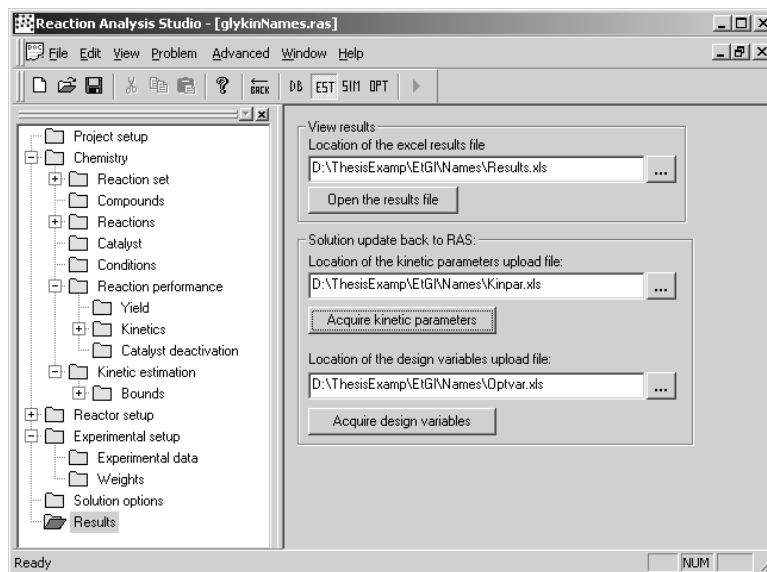

A spreadsheet shows the estimation results along with percentage errors, parity plots and sensitivities. This is generated by macros based on the output from the estimation.

Case Name	Enter the name of a case	Time of Run	25-09-2001 18:02
Weighted LSQ Error	6.24E-06		

RXN	Phase Measurement Errors	Exp_no	TEMP	ETO	ETG
24	SET1	1	0	0	0
25	SET1	2	0	0.04199	-0.24758
26	SET1	3	0	-0.05583	0.15095
27	SET1	4	0	-0.03837	0.06368
28	SET1	5	0	-0.10064	0.11496
29	SET1	6	0	0.02813	-0.06274
30	SET1	7	0	0.1525	-0.05291
31	SET1	8	0	0.11373	-0.02039
32	SET1	9	0	-0.50773	0.02281

RXN	Phase Compositions	Exp_no	TIME	TEMP	ETO_Meas	ETO_Calc	ETG_Meas	ETG_Calc
37	Exp_Set							
38	SET1	1	0	0	1	0	0	0
39	SET1	2	0.5	0	0.855	0.85484	0.145	0.14536

D

Reaction data – for example in section 5.2.2

The reaction data was constructed for a batch reactor using a dynamic simulator, the molar holdups resulting from the dynamic simulations have been converted into concentrations.

Set	Time [s]	Temperature [K]	Concentration [mol/L]				
			A	B	C	D	E
1.1	0	300	5.465e-2	5.465e-2	0	0	0
1.2	0.36	300	5.453e-2	5.459e-2	5.752e-5	5.767e-5	1.438e-7
1.3	3.6	300	5.352e-2	5.406e-2	5.361e-4	5.633e-4	2.722e-5
1.4	7.2	300	5.246e-2	5.345e-2	9.949e-4	1.098e-3	1.031e-4
1.5	14.4	300	5.049e-2	5.221e-2	1.727e-3	2.088e-3	3.61e-4
1.6	21.6	300	4.87e-2	5.098e-2	2.274e-3	2.982e-3	7.079e-4
1.7	28.8	300	4.709e-2	4.979e-2	2.701e-3	3.794e-3	1.093e-3
1.8	36	300	4.561e-2	4.866e-2	3.046e-3	4.533e-3	1.487e-3
1.9	43.2	300	4.427e-2	4.76e-2	3.332e-3	5.208e-3	1.876e-3
1.10	50.4	300	4.303e-2	4.661e-2	3.578e-3	5.829e-3	2.25e-3
1.11	57.6	300	4.189e-2	4.569e-2	3.795e-3	6.4e-3	2.605e-3
1.12	64.8	300	4.084e-2	4.483e-2	3.99e-3	6.927e-3	2.937e-3
1.13	72	300	3.987e-2	4.404e-2	4.17e-3	7.416e-3	3.247e-3
1.14	75.6	300	3.941e-2	4.366e-2	4.255e-3	7.647e-3	3.393e-3
1.15	79.2	300	3.896e-2	4.33e-2	4.337e-3	7.871e-3	3.534e-3
1.16	82.8	300	3.854e-2	4.295e-2	4.416e-3	8.086e-3	3.669e-3
1.17	86.4	300	3.812e-2	4.262e-2	4.494e-3	8.293e-3	3.8e-3
1.18	90	300	3.772e-2	4.229e-2	4.569e-3	8.494e-3	3.925e-3
1.19	93.6	300	3.734e-2	4.198e-2	4.643e-3	8.688e-3	4.045e-3
1.20	97.2	300	3.696e-2	4.168e-2	4.715e-3	8.876e-3	4.161e-3
1.21	100.8	300	3.66e-2	4.139e-2	4.785e-3	9.058e-3	4.272e-3
2.1	0	275	5.501e-2	5.501e-2	0	0	0
2.2	0.36	275	5.489e-2	5.495e-2	5.76e-5	5.774e-5	1.408e-7
2.3	3.6	275	5.388e-2	5.442e-2	5.371e-4	5.64e-4	2.69e-5
2.4	7.2	275	5.281e-2	5.381e-2	9.976e-4	1.1e-3	1.02e-4
2.5	14.4	275	5.084e-2	5.257e-2	1.734e-3	2.092e-3	3.579e-4

2.6	21.6	275	4.905e-2	5.133e-2	2.285e-3	2.988e-3	7.032e-4
2.7	28.8	275	4.743e-2	5.014e-2	2.714e-3	3.802e-3	1.088e-3
2.8	36	275	4.595e-2	4.901e-2	3.061e-3	4.544e-3	1.483e-3
2.9	43.2	275	4.46e-2	4.795e-2	3.349e-3	5.222e-3	1.873e-3
2.10	50.4	275	4.336e-2	4.695e-2	3.595e-3	5.845e-3	2.249e-3
2.11	57.6	275	4.222e-2	4.603e-2	3.812e-3	6.418e-3	2.607e-3
2.12	64.8	275	4.116e-2	4.517e-2	4.006e-3	6.949e-3	2.942e-3
2.13	72	275	4.018e-2	4.437e-2	4.185e-3	7.44e-3	3.255e-3
2.14	75.6	275	3.972e-2	4.399e-2	4.269e-3	7.672e-3	3.403e-3
2.15	79.2	275	3.927e-2	4.362e-2	4.351e-3	7.897e-3	3.546e-3
2.16	82.8	275	3.884e-2	4.327e-2	4.43e-3	8.113e-3	3.683e-3
2.17	86.4	275	3.842e-2	4.293e-2	4.507e-3	8.322e-3	3.815e-3
2.18	90	275	3.802e-2	4.26e-2	4.582e-3	8.524e-3	3.942e-3
2.19	93.6	275	3.763e-2	4.229e-2	4.655e-3	8.719e-3	4.065e-3
2.20	97.2	275	3.726e-2	4.198e-2	4.726e-3	8.908e-3	4.182e-3
2.21	100.8	275	3.689e-2	4.169e-2	4.796e-3	9.091e-3	4.295e-3
3.1	0	340	5.403e-2	5.403e-2	0	0	0
3.2	0.36	340	5.391e-2	5.397e-2	5.692e-5	5.707e-5	1.452e-7
3.3	3.6	340	5.291e-2	5.344e-2	5.301e-4	5.574e-4	2.73e-5
3.4	7.2	340	5.186e-2	5.284e-2	9.831e-4	1.087e-3	1.034e-4
3.5	14.4	340	4.991e-2	5.161e-2	1.705e-3	2.066e-3	3.611e-4
3.6	21.6	340	4.814e-2	5.039e-2	2.244e-3	2.951e-3	7.064e-4
3.7	28.8	340	4.654e-2	4.921e-2	2.665e-3	3.753e-3	1.088e-3
3.8	36	340	4.509e-2	4.809e-2	3.006e-3	4.484e-3	1.478e-3
3.9	43.2	340	4.376e-2	4.705e-2	3.291e-3	5.153e-3	1.862e-3
3.10	50.4	340	4.254e-2	4.607e-2	3.535e-3	5.766e-3	2.231e-3
3.11	57.6	340	4.141e-2	4.516e-2	3.752e-3	6.33e-3	2.579e-3
3.12	64.8	340	4.037e-2	4.432e-2	3.947e-3	6.852e-3	2.905e-3
3.13	72	340	3.941e-2	4.354e-2	4.128e-3	7.336e-3	3.208e-3
3.14	75.6	340	3.895e-2	4.317e-2	4.213e-3	7.564e-3	3.351e-3
3.15	79.2	340	3.852e-2	4.281e-2	4.296e-3	7.785e-3	3.489e-3
3.16	82.8	340	3.809e-2	4.247e-2	4.376e-3	7.997e-3	3.621e-3
3.17	86.4	340	3.768e-2	4.214e-2	4.454e-3	8.203e-3	3.749e-3
3.18	90	340	3.729e-2	4.182e-2	4.53e-3	8.401e-3	3.871e-3
3.19	93.6	340	3.691e-2	4.151e-2	4.604e-3	8.593e-3	3.988e-3
3.20	97.2	340	3.654e-2	4.121e-2	4.677e-3	8.778e-3	4.101e-3
3.21	100.8	340	3.618e-2	4.093e-2	4.748e-3	8.958e-3	4.21e-3
4.1	0	340	1.075e-1	5.375e-2	0	0	0
4.2	0.36	340	1.07e-1	5.352e-2	2.231e-4	2.24e-4	9.265e-7
4.3	3.6	340	1.033e-1	5.153e-2	2.015e-3	2.121e-3	1.057e-4
4.4	7.2	340	9.954e-2	4.939e-2	3.62e-3	4.0e-3	3.807e-4
4.5	14.4	340	9.325e-2	4.54e-2	5.944e-3	7.165e-3	1.22e-3
4.6	21.6	340	8.818e-2	4.189e-2	7.52e-3	9.718e-3	2.198e-3
4.7	28.8	340	8.402e-2	3.884e-2	8.647e-3	1.181e-2	3.167e-3

4.8	36	340	8.055e-2	3.621e-2	9.498e-3	1.356e-2	4.063e-3
4.9	43.2	340	7.763e-2	3.396e-2	1.018e-2	1.504e-2	4.858e-3
4.10	50.4	340	7.513e-2	3.201e-2	1.075e-2	1.63e-2	5.549e-3
4.11	57.6	340	7.297e-2	3.034e-2	1.124e-2	1.738e-2	6.14e-3
4.12	64.8	340	7.109e-2	2.89e-2	1.169e-2	1.833e-2	6.644e-3
4.13	72	340	6.945e-2	2.765e-2	1.209e-2	1.916e-2	7.069e-3
4.14	75.6	340	6.87e-2	2.709e-2	1.228e-2	1.954e-2	7.256e-3
4.15	79.2	340	6.8e-2	2.657e-2	1.246e-2	1.989e-2	7.427e-3
4.16	82.8	340	6.733e-2	2.608e-2	1.264e-2	2.022e-2	7.584e-3
4.17	86.4	340	6.671e-2	2.563e-2	1.281e-2	2.054e-2	7.727e-3
4.18	90	340	6.612e-2	2.52e-2	1.298e-2	2.083e-2	7.858e-3
4.19	93.6	340	6.556e-2	2.48e-2	1.314e-2	2.111e-2	7.978e-3
4.20	97.2	340	6.504e-2	2.443e-2	1.329e-2	2.138e-2	8.087e-3
4.21	100.8	340	6.454e-2	2.408e-2	1.344e-2	2.163e-2	8.187e-3
5.1	0	340	1.073e-1	5.364e-2	0	1.073e-2	1.073e-2
5.2	0.36	340	1.068e-1	5.349e-2	2.954e-4	1.095e-2	1.065e-2
5.3	3.6	340	1.031e-1	5.21e-2	2.69e-3	1.284e-2	1.015e-2
5.4	7.2	340	9.931e-2	5.052e-2	4.869e-3	1.473e-2	9.86e-3
5.5	14.4	340	9.297e-2	4.739e-2	8.087e-3	1.792e-2	9.831e-3
5.6	21.6	340	8.786e-2	4.447e-2	1.03e-2	2.049e-2	1.019e-2
5.7	28.8	340	8.368e-2	4.186e-2	1.188e-2	2.26e-2	1.072e-2
5.8	36	340	8.023e-2	3.958e-2	1.306e-2	2.434e-2	1.128e-2
5.9	43.2	340	7.734e-2	3.76e-2	1.398e-2	2.579e-2	1.182e-2
5.10	50.4	340	7.49e-2	3.589e-2	1.472e-2	2.702e-2	1.231e-2
5.11	57.6	340	7.282e-2	3.442e-2	1.534e-2	2.807e-2	1.274e-2
5.12	64.8	340	7.104e-2	3.316e-2	1.587e-2	2.897e-2	1.31e-2
5.13	72	340	6.95e-2	3.208e-2	1.633e-2	2.975e-2	1.342e-2
5.14	75.6	340	6.881e-2	3.16e-2	1.654e-2	3.01e-2	1.355e-2
5.15	79.2	340	6.816e-2	3.115e-2	1.674e-2	3.042e-2	1.368e-2
5.16	82.8	340	6.756e-2	3.074e-2	1.693e-2	3.073e-2	1.379e-2
5.17	86.4	340	6.7e-2	3.035e-2	1.711e-2	3.101e-2	1.39e-2
5.18	90	340	6.647e-2	2.999e-2	1.728e-2	3.128e-2	1.4e-2
5.19	93.6	340	6.598e-2	2.966e-2	1.744e-2	3.152e-2	1.408e-2
5.20	97.2	340	6.552e-2	2.935e-2	1.759e-2	3.176e-2	1.416e-2
5.21	100.8	340	6.508e-2	2.906e-2	1.774e-2	3.197e-2	1.424e-2
5.22	104.4	340	6.468e-2	2.879e-2	1.788e-2	3.218e-2	1.43e-2
5.23	108	340	6.43e-2	2.854e-2	1.801e-2	3.237e-2	1.436e-2
5.24	115.2	340	6.36e-2	2.809e-2	1.825e-2	3.272e-2	1.447e-2
5.25	122.4	340	6.299e-2	2.77e-2	1.848e-2	3.303e-2	1.455e-2
5.26	129.6	340	6.245e-2	2.735e-2	1.868e-2	3.33e-2	1.463e-2
5.27	136.8	340	6.197e-2	2.705e-2	1.886e-2	3.355e-2	1.469e-2
5.28	144	340	6.154e-2	2.679e-2	1.903e-2	3.376e-2	1.474e-2
5.29	158.4	340	6.083e-2	2.636e-2	1.931e-2	3.412e-2	1.481e-2
5.30	172.8	340	6.026e-2	2.602e-2	1.954e-2	3.44e-2	1.486e-2

5.31	187.2	340	5.982e-2	2.576e-2	1.973e-2	3.463e-2	1.49e-2
------	-------	-----	----------	----------	----------	----------	---------

Parity plots for the estimated vs. the measured (calculated) concentrations:

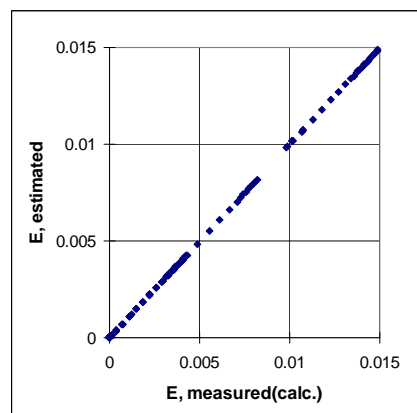
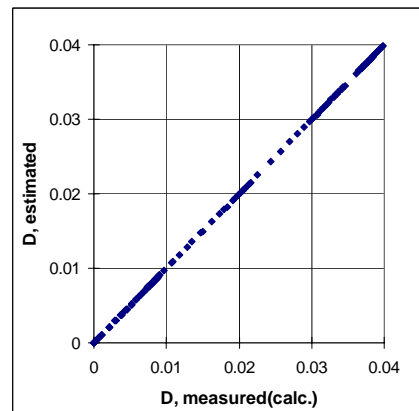
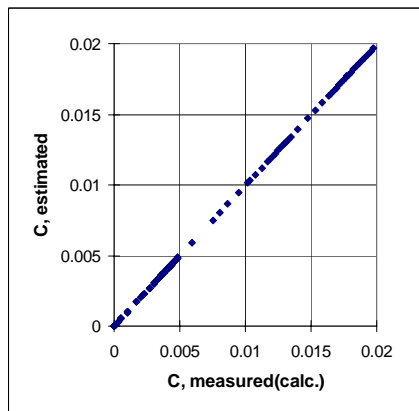
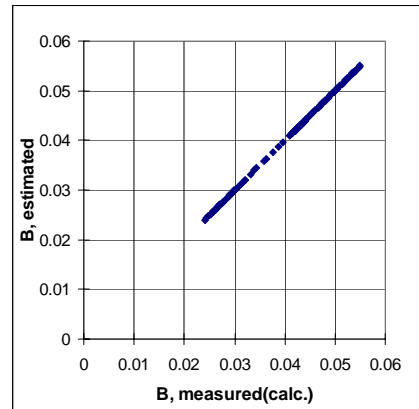
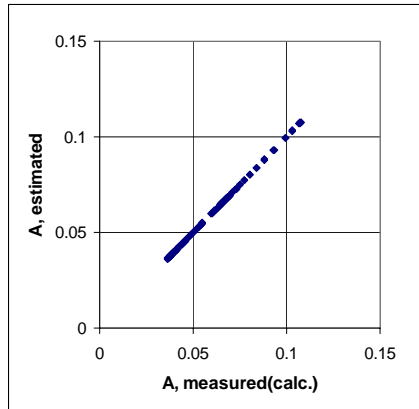

E

Additional results from Distillation design

Additional results from the application of the equilibrium based algorithm for distillation columns. The example can be found in section 5.3, concerning a distillation column with methanol and water as the key compounds.

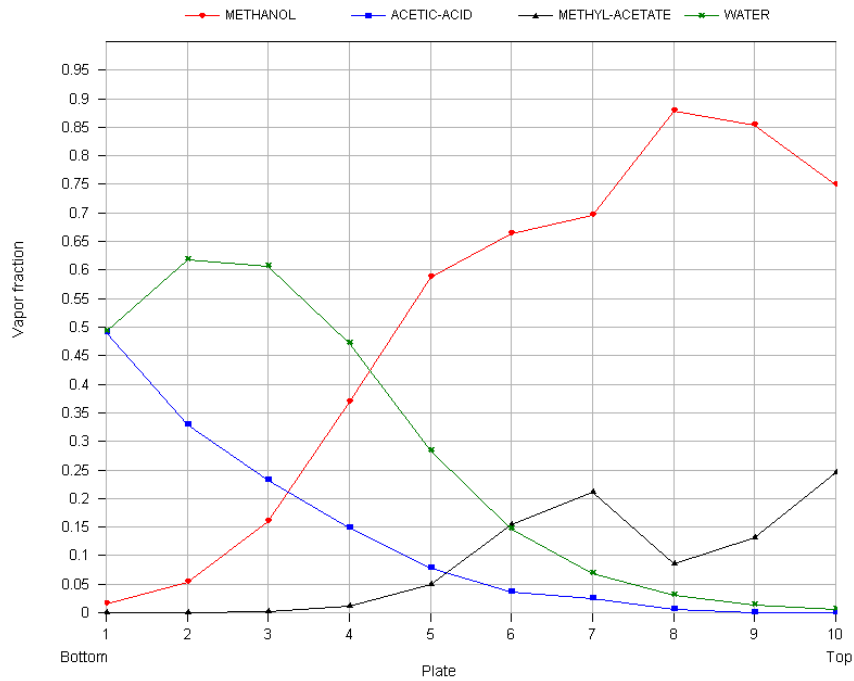

Tray vs vapor composition plot for the methanol / water split column.

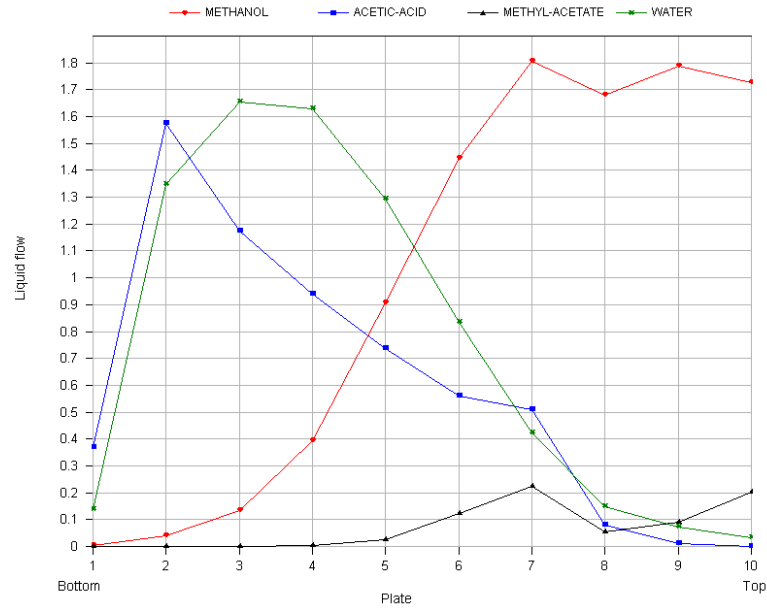

Tray vs internal liquid flows plot for the methanol / water split column.

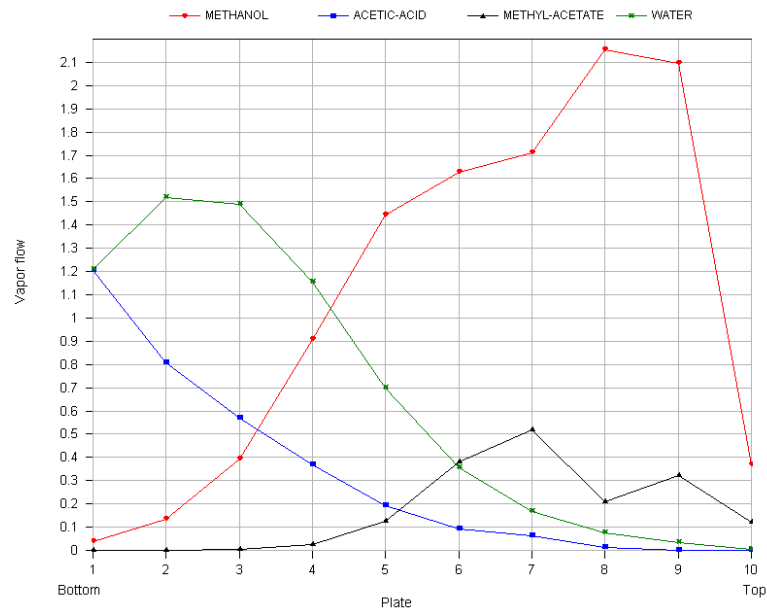

Tray vs internal vapor flows plot for the methanol / water split column.

F

Input file example for a MILP master problem

```
$TITLE D&G
$offsymxref offsymlist
option optcr=0.1, limrow=0, limcol=0;

* I is a counter for the binary design variables given in the
* vector Y(I)
* Y1 is reactor 80% conv on/off
* Y2 is reactor 70% conv on/off
* Y3 is extr dist on/off
* Y4 is dist+recycle on/off
* Y5 is dist+membrane on/off
SET I BinCount / 1*5 /;

* C is a counter for the contineous design variables given in
* the vector DSG_VAR(C)
* DSG_VAR(1) is hydrogen feed flowrate
* DSG_VAR(2) is purge fraction in the inner recycle loop
SET C ContVars / 1*2 /;

* Base case after a solved NLP values, for the variables in the
* object function
SCALARS
PROD_K / 6335.72588580 /
REACTOR_K / 145.77227715 /
PURGE_K / 93.01420 /
FEED_K / 5325.50550 /
SEP_K / 360.01029869 /
;

PARAMETERS
* Base case after a solved NLP values, for the cont. design
* variables
```

```
DSG_VAR_K(C)
/ 1 701.411
  2 0.05 /
```

```
* Base case after a solved NLP values, for the binary design
* variables
```

```
Y_K(I)
/ 1 1
  2 0
  3 0
  4 1
  5 0 /
```

```
*Derivatives for the variables in the object function (here
*product earnings) with respect to the cont. design variables
DPROD(C)
```

```
/ 1 -0.38252400
  2 63.75399999 /
```

```
*Values for the variables in the object function with respect
*to different values for the binary design variables,
*note that some values here are the same as for the base case
PROD_E(I)
```

```
/ 1 6335.72588580
  2 6336.66625730
  3 5992.87600000
  4 6335.72588580
  5 6310.57493280 /
```

```
*Reactor balance values (heat earnings - capital cost):
```

```
DR_BAL(C)
/ 1 0.60314890
  2 -1163.17053600 /
```

```
R_BAL(I)
/ 1 145.77227715
  2 240.81627842
  3 149.06021010
  4 145.77227715
  5 149.20735197 /
```

```
*Purge cost:
```

```
DPURGE_C(C)
/ 1 0.88800
  2 -176.00000 /
```

```
PURGE_C(I)
/ 1 93.01420
  2 90.43030
  3 118.32070
  4 93.01420
  5 93.58760 /

*Feed cost:
DFEED_COST(C)
/ 1 0.50000
  2 0.00000 /

FEED_COST(I)
/ 1 5325.50550
  2 5325.50550
  3 5325.50550
  4 5325.50550
  5 5325.50550 /

*Separation cost (heating+cooling+capital+solvent)
DSEP_COST(C)
/ 1 0.22036718
  2 722.99867410 /

SEP_COST(I)
/ 1 360.01029869
  2 495.15848806
  3 702.09711215
  4 360.01029869
  5 763.86083589 /

;

* Discrete design vars:
BINARY VARIABLE Y(I);
* Continuous design vars:
VARIABLE DSG_VAR(C);

VARIABLES CPROD(C), IPROD(I), OPROD, CRBAL(C), IRBAL(I), ORBAL,
CPURGE(C), IPURGE(I), OPURGE, CFEED(C), IFEED(I), OFEED, CSEP(C),
ISEP(I), OSEP, OBJ;

EQUATIONS
EPRODC(C), EPRODI(I), EPROD, ERBALC(C), ERBALI(I), ERBAL, EPURGEC(C),
```

```
EPURGEI(I),EPURGE,EFEEDC(C),EFEEDI(I),EFEED,ESEPC(C),ESEPI(I),
ESEP,EYREAC,EYSEP,FOBJ;
```

```
EPRODC(C).. CPROD(C) =E= DPROD(C)*(DSG_VAR(C)-DSG_VAR_K(C));
EPRODI(I).. IPROD(I) =E= (PROD_E(I)-PROD_K)*(Y(I)-Y_K(I));
EPROD.. OPROD =E= PROD_K + SUM(C, CPROD(C)) + SUM(I, IPROD(I));
ERBALC(C).. CRBAL(C) =E= DR_BAL(C)*(DSG_VAR(C)-DSG_VAR_K(C));
ERBALI(I).. IRBAL(I) =E= (R_BAL(I)-REACTOR_K)*(Y(I)-Y_K(I));
ERBAL.. ORBAL =E= REACTOR_K + SUM(C, CRBAL(C)) + SUM(I, IRBAL(I));
EPURGEC(C).. CPURGE(C) =E= DPURGE_C(C)*(DSG_VAR(C)-DSG_VAR_K(C));
EPURGEI(I).. IPURGE(I) =E= (PURGE_C(I)-PURGE_K)*(Y(I)-Y_K(I));
EPURGE.. OPURGE =E= PURGE_K + SUM(C, CPURGE(C)) + SUM(I, IPURGE(I));
EFEEDC(C).. CFEEED(C) =E= DFEED_COST(C)*(DSG_VAR(C)-DSG_VAR_K(C));
EFEEDI(I).. IFEEED(I) =E= (FEED_COST(I)-FEED_K)*(Y(I)-Y_K(I));
EFEED.. OFEED =E= FEED_K + SUM(C, CFEEED(C)) + SUM(I, IFEEED(I));
ESEPC(C).. CSEP(C) =E= DSEP_COST(C)*(DSG_VAR(C)-DSG_VAR_K(C));
ESEPI(I).. ISEP(I) =E= (SEP_COST(I)-SEP_K)*(Y(I)-Y_K(I));
ESEP.. OSEP =E= SEP_K + SUM(C, CSEP(C)) + SUM(I, ISEP(I));
EYREAC.. 1 =E= Y('1')+Y('2');
EYSEP.. 1 =E= Y('3')+Y('4')+Y('5');
FOBJ.. OBJ=E=(-OPROD-ORBAL+OPURGE+OFEED+OSEP);
```

```
Y.L('1')=1;
Y.L('2')=0;
Y.L('3')=0;
Y.L('4')=0;
Y.L('5')=1;
DSG_VAR.LO('1')=680;
DSG_VAR.UP('1')=750;
DSG_VAR.L('1')=700;
DSG_VAR.LO('2')=0.05;
DSG_VAR.UP('2')=0.12;
DSG_VAR.L('2')=0.07;
MODEL COMPLEX /ALL/;
```

```
SOLVE COMPLEX USING MIP MINIMIZING OBJ;
```

```
DISPLAY Y.L, DSG_VAR.L;
```

G

Result file for the acetone - chloroform CAMD problem

Number of compounds designed : 47792
Number of compounds selected : 53
Number of isomers designed : 528
Number of isomer selected : 23
Total time used to design : 35.22 s

'Screened Out' Statistics for Primary Calculations :

Functional group screening : 46990 of 47792
Normal Boiling point : 472 of 802
Solvent loss : 5 of 330
Solvent power : 198 of 325
Selectivity : 64 of 127
Azeotrop Calculation : 10 of 63

'Screened Out' Statistics for Secondary Calculations :

Normal Boiling point : 481 of 528
Solvent power : 23 of 47
Azeotrop Calculation : 1 of 24

Compounddata in the following order :

1. order description
2. order description

Calculated values for (in same line) :

1. Normal Boiling point (K)
2. Solvent loss ()
3. Solvent power ()
4. Selectivity ()
5. Azeotrop Calculation

Calculated secondary values (in next line)

Compound 1 :

3 CH3

1 CH2

1 C

1 CHO

1 (CH3)3C

389.66 0.894 5.89 6.57

388.17 0.894 5.89 6.57 0.00 / 0.00 K

Compound 2 :

3 CH3

1 CH2

1 C

1 CH3O

370.61 0.527 2.00 3.62

370.61 0.527 2.00 3.62 0.00 / 0.00 K

Compound 3 :

3 CH3

1 CH2

1 C

1 CH3O

1 (CH3)3C

370.61 0.527 2.00 3.62

368.98 0.527 2.00 3.62 0.00 / 0.00 K

Compound 4 :

3 CH3

2 CH

1 CHO

1 CH(CH3)CH(CH3)

389.55 0.898 6.09 6.79

394.94 0.898 6.09 6.79 0.00 / 0.00 K

Compound 5 :

3 CH3

2 CH

1 CH3O

1 CH(CH3)CH(CH3)

370.49 0.534 2.05 3.70
376.40 0.534 2.05 3.70 0.00 / 0.00 K

Compound 6 :

2 CH3
2 CH2
1 CH
1 CHO

1 CHCHO or CCHO

399.98 0.898 6.09 6.78
396.85 0.898 6.09 6.78 0.00 / 0.00 K

Compound 7 :

2 CH3
2 CH2
1 CH
1 CHO

399.98 0.898 6.09 6.78
399.98 0.898 6.09 6.78 0.00 / 0.00 K

Compound 8 :

2 CH3
2 CH2
1 CH
1 CHO

1 CHCHO or CCHO

399.98 0.898 6.09 6.78
396.85 0.898 6.09 6.78 0.00 / 0.00 K

Compound 9 :

2 CH3
2 CH2
1 CH
1 CHO

1 (CH3)2CH

399.98 0.898 6.09 6.78
396.61 0.898 6.09 6.78 0.00 / 0.00 K

Compound 10 :

2 CH3
2 CH2
1 CH
1 CH3O

381.91 0.534 2.05 3.70
381.91 0.534 2.05 3.70 0.00 / 0.00 K

Compound 11 :

2 CH3
2 CH2
1 CH
1 CH3O

381.91 0.534 2.05 3.70
381.91 0.534 2.05 3.70 0.00 / 0.00 K

Compound 12 :

2 CH3
2 CH2
1 CH
1 CH3O

381.91 0.534 2.05 3.70
381.91 0.534 2.05 3.70 0.00 / 0.00 K

Compound 13 :

2 CH3
2 CH2
1 CH
1 CH3O

1 (CH3)2CH

381.91 0.534 2.05 3.70
378.23 0.534 2.05 3.70 0.00 / 0.00 K

Compound 14 :

1 CH3
4 CH2
1 CH0

1 lin.C4term.alkyl (CH3CH2CH2CH2) *SBI0

409.90 0.898 6.08 6.77

409.90 0.898 6.08 6.77 0.00 / 0.00 K

Compound 15 :

1 CH3

4 CH2

1 CH30

1 lin.C4term.alkyl (CH3CH2CH2CH2) *SBI0

392.73 0.534 2.04 3.69

392.73 0.534 2.04 3.69 0.00 / 0.00 K

Compound 16 :

3 CH3

2 CH2

1 C

1 CHO

1 CHCHO or CCHO

415.91 0.853 5.37 6.08

413.02 0.853 5.37 6.08 0.00 / 0.00 K

Compound 17 :

3 CH3

2 CH2

1 C

1 CHO

415.91 0.853 5.37 6.08

415.91 0.853 5.37 6.08 0.00 / 0.00 K

Compound 18 :

3 CH3

2 CH2

1 C

1 CHO

1 CHCHO or CCHO

415.91 0.853 5.37 6.08

413.02 0.853 5.37 6.08 0.00 / 0.00 K

Compound 19 :

3 CH3

2 CH2

1 C

1 CHO

1 (CH3)3C

415.91 0.853 5.37 6.08

414.60 0.853 5.37 6.08 0.00 / 0.00 K

Compound 20 :

4 CH3

1 CH

1 C

1 CHO

1 CH(CH3)C(CH3)2

406.28 0.853 5.38 6.08

415.01 0.853 5.38 6.08 0.00 / 0.00 K

Compound 21 :

4 CH3

1 CH

1 C

1 CHO

1 CH(CH3)C(CH3)2

406.28 0.853 5.38 6.08

415.01 0.853 5.38 6.08 0.00 / 0.00 K

Compound 22 :

3 CH3

1 CH2

2 CH

1 CHO

1 (CH3)2CH

1 CHCHO or CCHO

415.81 0.856 5.52 6.25

409.76 0.856 5.52 6.25 0.00 / 0.00 K

Compound 23 :

3 CH3

1 CH2

2 CH

1 CHO

1 (CH3)2CH

1 CHCHO or CCHO

415.81 0.856 5.52 6.25

409.76 0.856 5.52 6.25 0.00 / 0.00 K

H

Stream summary for the methanol production

STREAM NUMBER	1	2	3
-----	-----	-----	-----
TEMPERATURE (K)	483.50000	484.25485	250.00000
PRESSURE (bar)	50.80000	50.00000	50.00000
ENTHALPY(MJ/kmole)	-49.35428	-41.07016	-23.99772
ENTROPY(MJ/K/kmole)	-1.77563	-1.91134	-0.74401
U-ENERGY(MJ/kmole)	-49.68413	-41.40053	-24.16828
DENS. (kmole/m ³)	1.26367	1.24183	2.40544
VAPOUR FRACTION	1.00000	1.00000	1.00000
LIGHT LIQUID FRAC.	0.00000	0.00000	0.00000
HEAVY LIQUID FRAC.	0.00000	0.00000	0.00000
----- (kmole/hr) -----	-----	-----	-----
CARBON-MONOXIDE	0.25000	4.53644	4.53633
CARBON-DIOXIDE	0.37500	3.37161	3.34520
WATER	0.00000	0.31561	0.00047
HYDROGEN	1.87500	52.05330	52.05330
METHANOL	0.00000	0.52471	0.00510
1-HEXANOL	0.00000	0.03000	0.00000
DIMETHYL-ETHER	0.00000	0.07169	0.05221
-----	-----	-----	-----
TOTAL	2.50000	60.90336	59.99261
=====	=====	=====	=====
STREAM NUMBER	4	5	6
-----	-----	-----	-----
TEMPERATURE (K)	250.00000	483.50000	250.00000
PRESSURE (bar)	50.00000	50.80000	50.00000
ENTHALPY(MJ/kmole)	-3.38755	-42.87926	-23.99772
ENTROPY(MJ/K/kmole)	-0.00620	-1.93252	-0.74401
U-ENERGY(MJ/kmole)	-3.40177	-43.20912	-24.16828
DENS. (kmole/m ³)	28.84790	1.26367	2.40544
VAPOUR FRACTION	0.00000	1.00000	1.00000

LIGHT LIQUID FRAC.	1.00000	0.00000	0.00000
HEAVY LIQUID FRAC.	0.00000	0.00000	0.00000
----- (kmole/hr) -----			
CARBON-MONOXIDE	0.00011	4.74097	0.04536
CARBON-DIOXIDE	0.02641	3.68675	0.03345
WATER	0.31514	0.00047	0.00000
HYDROGEN	0.00000	53.40777	0.52053
METHANOL	0.51961	0.00505	0.00005
1-HEXANOL	0.03000	0.00000	0.00000
DIMETHYL-ETHER	0.01948	0.05169	0.00052
-----	-----	-----	-----
TOTAL	0.91075	61.89269	0.59993
=====	=====	=====	=====

STREAM NUMBER	7	8	9
-----	-----	-----	-----
TEMPERATURE (K)	250.00000	483.50000	300.00000
PRESSURE (bar)	50.00000	50.80000	50.00000
ENTHALPY (MJ/kmole)	-23.99772	-41.10879	5.94804
ENTROPY (MJ/K/kmole)	-0.74401	-1.90933	0.02619
U-ENERGY (MJ/kmole)	-24.16828	-41.43865	5.90558
DENS. (kmole/m ³)	2.40544	1.26367	9.66254
VAPOUR FRACTION	1.00000	1.00000	0.00000
LIGHT LIQUID FRAC.	0.00000	0.00000	1.00000
HEAVY LIQUID FRAC.	0.00000	0.00000	0.00000
----- (kmole/hr) -----			
CARBON-MONOXIDE	4.49097	4.53644	0.00000
CARBON-DIOXIDE	3.31175	3.37161	0.00000
WATER	0.00047	0.31561	0.00000
HYDROGEN	51.53277	52.05330	0.00000
METHANOL	0.00505	0.52471	0.00000
1-HEXANOL	0.00000	0.00000	0.03000
DIMETHYL-ETHER	0.05169	0.05169	0.02000
-----	-----	-----	-----
TOTAL	59.39269	60.85336	0.05000
=====	=====	=====	=====

STREAM NUMBER	10	11	12
-----	-----	-----	-----
TEMPERATURE (K)	233.87787	341.33228	337.23602
PRESSURE (bar)	1.00000	1.00000	1.00000
ENTHALPY (MJ/kmole)	4.86015	5.27440	40.52026
ENTROPY (MJ/K/kmole)	0.03011	0.02247	0.12228
U-ENERGY (MJ/kmole)	4.72273	5.27410	40.29019
DENS. (kmole/m ³)	0.05969	26.90116	0.03566

VAPOUR FRACTION	0.86083	0.00000	1.00000
LIGHT LIQUID FRAC.	0.13917	0.00000	0.00000
HEAVY LIQUID FRAC.	0.00000	1.00000	0.00000
----- (kmole/hr) -----			
CARBON-MONOXIDE	0.00011	0.00000	0.00000
CARBON-DIOXIDE	0.02641	0.00000	0.00000
WATER	0.00000	0.31514	0.00131
HYDROGEN	0.00000	0.00000	0.00000
METHANOL	0.00001	0.51961	0.51625
1-HEXANOL	0.00000	0.03000	0.00000
DIMETHYL-ETHER	0.01628	0.00320	0.00320

TOTAL	0.04281	0.86794	0.52077
=====			

STREAM NUMBER	13

TEMPERATURE (K)	367.61335
PRESSURE (bar)	1.00000
ENTHALPY (MJ/kmole)	8.53718
ENTROPY (MJ/K/kmole)	0.02714
U-ENERGY (MJ/kmole)	8.53694
DENS. (kmole/m ³)	34.85035
VAPOUR FRACTION	0.00000
LIGHT LIQUID FRAC.	1.00000
HEAVY LIQUID FRAC.	0.00000
----- (kmole/hr) -----	
CARBON-MONOXIDE	0.00000
CARBON-DIOXIDE	0.00000
WATER	0.31382
HYDROGEN	0.00000
METHANOL	0.00336
1-HEXANOL	0.03000
DIMETHYL-ETHER	0.00000

TOTAL	0.34718
=====	

THE TIME SPENT IN IS:

1.84200 s

List of definitions

CAMD	Computer Aided Molecular Design – the generation of molecules from fragments using a computerized technique
CAMS	Computer Aided Molecular Search – identification of compounds having specific properties by systematic searching in databases.
CAPEC	Computer Aided Process Engineering Center – A research center at the Department of Chemical Engineering at the Technical University of Denmark. The work described in this thesis was carried out at CAPEC
cold stream	Stream that needs heating
cooling utilities	External sources used for cooling (i.e. cold water)
CSTR	Continuous Stirred Tank Reactor
EH&S	Environment, Health and Safety
Equation oriented	A strategy for solving mathematical problems with process flowsheets
feasible flowsheet	A flowsheet that is valid (can be used), but which is not necessarily optimal
GCA	Group Contribution Approach – property prediction based on the assumption that a fragment has the same contribution to a property regardless of the compound it is found in
heating utilities	External sources used for heating (i.e. steam)
HEN	Heat exchanger networks – A network of heat exchangers, where process fluids from the production plant (or plants) can exchange heat
hot stream	Stream that needs cooling
IDHK	Identity of the heavy key
IDLK	Identity of the light key

MEN	Mass Exchange Network
MILP	Mixed Integer Linear Programming
MINLP	Mixed Integer Non Linear Programming – The difference from a normal NLP is that some of the design variables is discrete variables (they can only have integer values)
NLP	Non Linear Programming – A definition of a non linear optimization problem, where for a given objective a set optimal continuous (design) variables are determined
P&ID	Piping and Instrumentation Diagram
PFD	Process Flowsheet Diagram - A diagram of the process equipment and how these are connected.
PFR	Plug Flow Reactor
Process synthesis	The problem of generating, modifying or optimizing a (manufacturing) process
properties	The physical and chemical properties of a compound (e.g. boiling point, melting point etc.)
Reactor networks	A network of reactors where chemical reactions relevant to the process occurs, the network may involve interconnected reactors, mixing, recycling, heat exchange, etc.
SEN	State equipment network
Separation synthesis	The problem of selecting and sequencing separation techniques able to perform separations tasks needed in the process
Separation task	The task of separating a mixture of chemical species into separate streams, which each are more rich in some of the species and less rich in other species
Separation technique	A technique (typically a unit operation) which is able to handle a separation task
SQP	Successive Quadratic Programming. A mathematical optimization method for the solution of NLPs.

STN	State task network
thermal pinch point	A temperature at which the hot and cold composite curves just touch, and where therefore, the driving force are at a minimum.

Nomenclature

BP_s	A set of binary component pair in separation block s , the number of elements in the set is denoted by $ BP_s $
$N_{F,0}$	Number of separation alternatives not using solvents
$N_{F,i}$	Number of solvents considered for solvent based alternative i
N_F	Total number of separation alternatives
N_{sbt}	Number of separation techniques using solvents
NC	Number of components
NC_s	Number of compounds existing in separation block s
NS	Number of sequences
NT	Number of potential separation techniques
R	A set of reaction blocks, the number of elements in the set are denoted by $ R $
S	A set of separation blocks, the number of elements in the set are denoted by $ S $
$S_{i,j}$	The separation efficiency of component i with respect to separation technique j
T_s	A set of separation tasks required in separation block s
R	Reflux ratio

References

- Abrams, D. and Prausnitz, J. (1975). Statistical Thermodynamics of Liquid Mixtures: A New Expression for the Excess Gibbs Energy of Partly or Completely Miscible Systems. *AIChE Journal*, **21**, 116–128.
- Aggarwal, A. and Floudas, C. (1990). Synthesis of General Distillation Sequences. *Comp. Chem. Engng.*, **14**, 631–653.
- Agreda, V.; Partin, L. and Heise, W. (1990). High-Purity Methyl Acetate Via Reactive Distillation. *Chemical Engineering Progress*, **86**(feb), 40–46.
- Ahmad, B. and Barton, P. (1996). Homogeneous Multicomponent Azeotropic Batch Distillation. *AIChE Journal*, **42**, 3419–3433.
- Andrecovich, M. and Westerberg, A. (1985). An MILP Formulation for Heat-Integrated Distillation Sequence Synthesis. *AIChE Journal*, **31**, 1461.
- Aspen Technology Inc. (- 2000). *ASPEN Plus User's Guide*. (www.aspentech.com).
- Balakrishna, S. and Biegler, L. (1992). A Constructive Targeting Approach for the Synthesis of Isothermal Reactor Networks. *Ind. Eng. Chem Research*, **31**, 300–.
- Balakrishna, S. and Biegler, L. (1993). A Unified Approach for the Simultaneous Synthesis of Reaction, Energy, and Separation Systems. *Ind. Eng. Chem. Research.*, **32**, 1372–1382.
- Bamapoulos, G.; Nath, R. and Motard, R. (1988). Heuristic Synthesis of Non-sharp Separation Sequences. *AIChE Journal*, **34**, 763–780.
- Barbosa, D. and Doherty, M. (1988). Design of Multicomponent Reactive Columns. *ICHEME Symposium Series*, **194**, B369.
- Barnicki, S. and Fair, J. (1990). Separation System Synthesis: A Knowledge-Based Approach. 1. Liquid Mixture Separations. *Ind. Eng. Chem. Research*, **29**, 421–432.
- Barnicki, S. and Fair, J. (1992). Separation System Synthesis: A Knowledge-Based Approach. 2. Gas/Vapor Mixtures. *Ind. Eng. Chem. Research*, **31**, 1679–1694.
- Bekiaris, N. and Morari, M. (1996). Multiple Steady States in Distillation: ∞/∞ Predictions, Extensions, and Implications for Design, Synthesis and Simulation. *Ind. Eng. Chem. Res.*, **35**, 4262–4280.

- Biegler, L.; Grossmann, I. and Westerberg, A. (1997). *Systematic Methods of Chemical Process Design*. Prentice Hall PTR, One Lake Street, Upper Saddle River, New Jersey 07458.
- Bossen, B. (1995). *Simulation and Optimization of Ammonia Plants*. Ph.D. thesis, Dep. of Chem. Engng., Tech. Univ. of Denmark.
- Briones, V. and Kokossis, A. (1999). Hypertargets: A Conceptual Programming Approach for the Optimisation of Industrial Heat Exchanger Networks – I. Grassroot Design and Network Complexity. *Chem. Engng. Science*, **54**, 519–539.
- Brooke, A.; Kendrick, D. and Meetaus, A. (1988). *GAMS: A User's Guide*. Scientific Press, Redwood City, CA.
- Bussche, K. and Froment, G. (1996). A Steady-State Kinetic Model for Methanol Synthesis and the Water Gas Shift Reaction on a Commercial Cu/ZnO/Al₂O₃ Catalyst. *Journal of Catalysis*, **161**, 1–10.
- Cabezas, H.; Zhao, R.; Bare, C. and Nishtala, S. (1996). A Computer Program for Assisting the Design and Replacement of Environmentally Objectionable Solvent. In *AiChE 1996 Annual Meeting*, Chicago, IL.
- Cabezas, H.; Bare, J. and Mallick, S. (1999). Pollution Prevention with Chemical Process Simulators: The Generalized Waste Reduction (WAR) Algorithm—Full Version. *Comp. Chem. Engng.*, **23**(4–5), 623–634.
- Ciric, A. and Floudas, C. (1991). Heat Exchanger Network Synthesis Without Decomposition. *Comp. Chem. Engng.*, **15**, 385–396.
- Constantinou, L. and Gani, R. (1994). New Group-Contribution Method for the Estimation of Properties of Pure Compounds. *AIChE J.*, **10**, 1697–1710.
- Daichendt, M. and Grossmann, I. (1997). Integration of Hierarchical Decomposition and Mathematical Programming for the Synthesis of Process Flowsheets. *Computes and Chemical Engineering*, **22**(1-2), 147–175.
- Daubert, T. and Danner, R. (1989). *Physical and Thermodynamic Properties of Pure Compounds: Data Compilation*. Hemisphere, New York.
- Douglas, J. (1985). A Hierarchical Decision Procedure for Process Synthesis. *AIChE Journal*, **31**(3), 353–362.
- Duran, M. and Grossmann, I. (1986a). An outer-approximation algorithm for a class of mixed-integer nonlinear programs. *Mathematical Programming*, **36**, 307–339. mathematical programming, outer-approximation MINLP-algorithm, process synthesis.
- Duran, M. and Grossmann, I. (1986b). Simultaneous Optimization and Heat Integration of Chemical Processes. *AIChE Journal*, **32**(1), 123–138.

- Duvedi, A. P. and Achenie, L. E. K. (1996). Designing Environmentally Safe Refrigerants using Mathematical Programming. *Chemical Engineering Science*, **51**(15), 3727–3739.
- El-Halwagi, M. M. (1997). *Pollution Prevention Through Process Integration: Systematic Design Tools*. Academic Press, San Diego, CA, USA.
- El-Halwagi, M. M. and Manousiouthakis, V. (1989). Synthesis of Mass Exchange Networks. *AIChE Journal*, **35**, 1233–1244.
- Fiedler, E.; Grossmann, G.; Kersebohm, B.; Weiss, G. and Witte, C. (1990). Methanol. *Ullmann's Encyclopedia of Industrial Chemistry*, **A 16**, 465–486.
- Floudas, C.; Ciric, A. and Grossmann, I. (1986). Automatic synthesis of optimum heat exchanger network configurations. *AIChE Journal*, **32**, 276.
- Fogler, H. (1992). *Elements of Chemical Reaction Engineering*. Prentice Hall, Inc., Englewood Cliffs, New Jersey 07632, second edition edition.
- Fredenslund, A.; Gmehling, J. and Rasmussen, P. (1977). *Vapour-Liquid Equilibria Using UNIFAC*. Elsevier, Amsterdam.
- Friedler, F.; Fan, L. T.; Kalotai, L. and Dallos, A. (1998). A Combinatorial Approach for Generating Candidates Molecules with Desired Properties Based on Group Contribution. *Computers Chem. Engng.*, **22**(6), 809–817.
- Gani, R. and Bek-Pedersen, E. (2000). Simple New Algorithm for Distillation Column Design. *AIChE J.*, **46**(6), 1271–1274.
- Gani, R. and Harper, P. M. (1999). Computer Aided Product Design and Pollution Prevention Through Substitution. In S. Sikdar and U. Diwekar, editors, *Tools and Methods for Pollution Prevention*, pages 299–315. NATO ARW, Kluwer Academic Publishers.
- Gani, R. and O'Connell, J. P. (1989). A Knowledge Based System For The Selection Of Thermodynamic Models. *Computers Chem. Engng.*, **13**(4–5), 397–404.
- Gani, R.; Nielsen, B. and Fredenslund, A. (1991). A Group Contribution Approach to Computer Aided Molecular Design. *AIChE J.*, **37**(9), 1318–1332.
- Gani, R.; Hytoft, G.; C, C. J. and Jensen, A. K. (1997). An Integrated Computer Aided System for Integrated Design of Chemical Processes. *Computers Chem. Engng.*, **21**(10), 1135–1146.
- Glasser, D.; Hildebrandt, D. and Crowe, C. (1987). A Geometric Approach to Steady Flow Reactors: The Attainable Region and Optimization in Concentration Space. *Ind. Eng. Chem. Research*, **26**, 1803–1810.

- Graaf, G.; Sijtsema, P.; Stamhuis, E. and Joosten, G. (1986). Chemical Equilibria in Methanol Synthesis. *Chem. Eng. Sci.*, **41**, 2883–2890.
- Graaf, G.; Stamhuis, E. and Beenackers, A. (1988). Kinetics of Low-Pressure Methanol Synthesis. *Chem. Eng. Sci.*, **43**, 3185–3195.
- Grossmann, I. and Daichendt, M. (1996). New Trends in Optimization-Based Approaches to Process Synthesis. *Comp. Chem. Engng.*, **20**, 665–683.
- Grossmann, I. E. and Kocis, G. (1989). A Modeling Decomposition Strategy for MINLP Optimisation of Process Flowsheets. *Computers and Chemical Engineering*, **13**, 797–819.
- Gundersen, T. and Naess, L. (1988). The Synthesis of Cost Optimal Heat Exchanger Networks: An Industrial Review of the State of the Art. *Comp. Chem. Engng.*, **12**, 503–530.
- Han, S.; Jin, Y. and Yu, Z. (1997). Application of a Fluidized Reaction Distillation Column for Hydrolysis of Methyl Acetate. *Chemical Engineering Journal*, **66**, 227–230.
- Harper, P. (2000). *A Multi-Phase, Multi-Level Framework for Computer Aided Molecular Design*. Ph.D. thesis, Department of Chemical Engineering, Technical University of Denmark.
- Harper, P. and Gani, R. (2001). Computer Aided Tools for Design/Selection of Environmentally Friendly Substances. In M. El-Halwagi and S. Sikdar, editors, *Process Design Tools for the Environment*, page Chapter 7. Taylor & Francis, Philadelphia, USA.
- Harper, P. and Hostrup, M. (1998). *Quick-Guide For ProCAMD*. CAPEC, Dep. of Chem. Eng., Tech. Univ. of Denmark.
- Harper, P.; Hostrup, M. and Gani, R. (2000). Design of Environmentally Benign Processes: Integration of Solvent Design and Process Synthesis. In *Clean Products and Processes II*, California, USA, 14–19 November 1999. Lake Arrowhead.
- Harper, P. M.; Gani, R.; Ishikawa, T. and Kolar, P. (1999). Computer Aided Molecular Design with Combined Molecular Modeling and Group Contribution. *Fluid Phase Equilibria*, **158–160**, 337–347.
- Hauan, S. and Lien, K. (1998). A Phenomena Based Design Approach to Reactive Distillation. *Chemical Engineering Research and Design*, **76**, 396–407.
- Hauan, S.; Westerberg, A. and Lien, K. (1999). Phenomena Based Analysis of Fixed Points in Reactive Separation Systems. *Chemical Engineering Science*, **55**, 1053–1075.

- Henriksen, J. and Støy, S. (1999). *Procesoptimering Gennem ICAS*. Master's thesis, CAPEC, Dep. of Chem. Engng., Tech. Univ. of Denmark.
- Henriksen, J. P.; Støy, S. F.; Russel, B. and Gani, R. (2000). A Novel Interactive MINLP Solver for CAPE Applications. *European Symposium on Computer Aided Process Engineering*, **10**, 7–12.
- Hildebrandt, D. and Biegler, L. T. (1995). Synthesis of Reactor Networks. *AIChE Symposium Series*, **91**, 52–67. Fourth International Conference on Foundations of Computer-Aided Process Design.
- Hodel, A. E. (1993). Butyl acetate replaces toluene to remove phenol from water. *Chemical Processing*. March.
- Hohmann, E. (1971). *Optimum Networks for Heat Exchange*. Ph.D. thesis, University of Southern California, LA, USA.
- Horn, F. (1964). Attainable Regions in Chemical Reaction Technique. *The Third European Symposium on Chemical Reaction Engineering*. London: Pergamon.
- Hostrup, M.; Harper, P. M. and Gani, R. (1999). Design Of Environmentally Benign Processes: Integration Of Solvent Design And Process Synthesis. *Computers Chem. Engng.*, **23**, 1395–1414.
- Hostrup, M.; Gani, R.; Kravanja, Z.; Sorsak, A. and Grossmann, I. (2001). Integration of Thermodynamic Insights and MINLP Optimization for the Synthesis, Design and Analysis of Process Flowsheets. *Computers Chem. Engng.*, **25**, 73–83.
- Hyprotech Ltd. (- 2000). *HYSYS User's Guide*. (www.hyprotech.com).
- Ismail, S.; Pistikopoulos, E. and Papalexandri, K. (1999). Synthesis of Reactive and Combined Reactor/Separation Systems Utilizing a Mass/Heat Exchange Transfer Module. *Chem. Eng. Sci.*, **54**, 2721–2729.
- Jakslund, C. (1996). *Separation Process Design and Synthesis Based on Thermodynamic Insights*. Ph.D. thesis, Department of Chemical Engineering, Technical University of Denmark.
- Jakslund, C. A.; Gani, R. and Lien, K. (1995). Separation Process Design and Synthesis Based on Thermodynamic Insights. *Chemical Engineering Science*, **50**(3), 511–530.
- Joback, K. G. and Reid, R. C. (1987). Estimation of Pure-Component Properties from Group Contributions. *Chem. Engng. Commun.*, **57**, 233–243.
- Karush, N. (1939). Master's thesis, University of Chicago.
- King, C. J. (1980). *Separation Processes*. McGraw-Hill, Inc., New York.

- Koggersbøl, A. (1995). *Distillation Column Dynamics Operability and Control*. Ph.D. thesis, CAPEC, Dep. of Chem. Engng., Tech. Univ. of Denmark.
- Kokossis, A. C. and Floudas, C. A. (1994). Optimization of Complex Reactor Networks – II. Nonisothermal Operation. *Chemical Engineering Science*, **49**, 1037.
- Kravanja, Z. and Glavic, P. (1997). Cost Targeting for HEN Through Simultaneous Optimization Approach: A Unified Pinch Technology and Mathematical Programming Design of Large HEN. *Comp. Chem Engng.*, **21**, 833–853.
- Kravanja, Z. and Grossmann, I. E. (1994). New Developments and Capabilities in PROSYN - An Automated Topology and Parameter Process Synthesizer. *Computers and Chemical Engineering*, **18**, 1097–1114.
- Krishna, R. and Sie, S. (1994). Strategies for Multiphase Reactor Selection. *Chemical Engineering Science*, **49**, 4029–4065.
- Kuhn, H. and Tucker, A. (1951). Nonlinear Programming. In J. Neyman, editor, *Proceedings of the Second Berkeley Symposium on Mathematical Statistics and Probability*, page 481, Berkeley, CA. University of California Press.
- Laidler, K. (1987). *Chemical Kinetics*. HarperCollinsPublishers, 10 East 53d Street, New York, NY.
- Li, Z. and Hua, B. (2000). Modeling and Optimizing for Heat Exchanger Networks Synthesis Based on Expert System and Exergo-Economic Objective Function. *Comp. Chem. Engng.*, **24**, 1223–1228.
- Linnhoff, B. and Hindmarsh, E. (1983). The Pinch Design Method for Heat Exchanger Networks. *Chem. Eng. Sci.*, **38**, 745–763.
- Lyman, L. J.; Reehl, W. F. and Rosenblatt, D. H., editors (1990). *Handbook of Chemical Property Estimation Methods, Environmental Behavior of Organic Compounds*. American Chemical Society, Washington DC.
- Malone, M. and Doherty, M. (1995). Separation System Synthesis for Nonideal Liquid Mixtures. *AIChE Symposium Series*, **91**, 9–18. Fourth International Conference on Foundations of Computer-Aided Process Design.
- Marcoulaki, E. C. and Kokossis, A. C. (1998). Molecular Design Synthesis Using Stochastic Optimisation as a Tool for Scoping and Screening. *Computers Chem. Engng.*, **22**(Suppl.), S11–S18.
- Nielsen, J.; Hansen, M. and Jørgensen, S. (1996). Heat Exchanger Network Modelling Framework for Optimal Design and Retrofitting. *Comp. Chem. Engng.*, **20**, S249–S254.

- Nielsen, T. and Gani, R. (2000). *TML - Thermodynamic Model Library, Version 1.1*. CAPEC, Department of Chemical Engineering, Technical University of Denmark.
- Nielsen, T. L.; Harper, P. M.; Hostrup, M. and Gani, R. (1999). *ProPred 2.5*. CAPEC, Dep. of Chem. Eng., Tech. Univ. of Denmark.
- Nielsen, T. L.; Abildskov, J.; Harper, P. M.; Papaconomou, I. and Gani, R. (2000). The CAPEC Database. In *14th SYMPOSIUM ON THERMOPHYSICAL PROPERTIES*, Colorado, June 25-30. Boulder.
- Odele, O. and Macchietto, S. (1993). Computer Aided Molecular Design: A Novel Method for Optimal Solvent Selection. *Fluid Phase Equilibria*, **82**, 47–54.
- Papalexandri, K. and Pistikopoulos, E. (1995). A Process Synthesis Modelling Framework Based on Mass/Heat Transfer Module Hyperstructure. *Comp. Chem. Eng.*, **19 (Suppl.)**, S71–S76.
- Papalexandri, K. and Pistikopoulos, E. (1996). Generalized Modular Representation Framework for Process Synthesis. *AIChE Journal*, **42(4)**, 1010–1032.
- Papoulias, S. and Grossmann, I. (1983). A Structural Optimization Approach in Process Synthesis – II. Heat Recovery Networks. *Comp. Chem. Engng.*, **7**, 707–721.
- Pérez-Cisneros, E. and Daza, O. (2000). Reactive Distillation Columns: Graphical and Multi-Stage Design Methods. In *2000 AIChE Annual Meeting*, page paper 245e, California, Nov. 12-17. Los Angeles.
- Pérez-Cisneros, E.; Gani, R. and Michelsen, M. (1997). Reactive Separation Systems I. Computation of Physical and Chemical Equilibrium. *Chem. Eng. Science*, **52**, 527.
- Pérez-Cisneros, E. S. (1997). *Modelling, Design and Analysis of Reactive Separation Processes*. Ph.D. thesis, Department of Chemical Engineering, Technical University of Denmark.
- Perry, R. and Green, D. (1984). *Perry's Chemical Engineers' Handbook*. McGraw-Hill Book Comp., New York, USA, 6th edition.
- Pistikopoulos, E. and Stefanis, S. (1998). Optimal Solvent Design for Environmental Impact Minimization. *Computers Chem. Engng.*, **22(6)**, 717–733.
- Pistikopoulos, E.; Stefanis, S. and Livingston, A. (1994). A Methodology for Minimum Environmental Impact Analysis. In *AIChE Symposium Series, Pollution Prevention Through Process and Product Modification*, volume in press. AIChE, New York.

- Poling, B.; Prausnitz, J. and O'Connell, J. (2000). *The Properties of Gases and Liquids*. McGraw-Hill Book Comp., New York, fifth edition.
- Pöpken, T.; Steinigeweg, S. and Gmehling, J. (2001). Synthesis and Hydrolysis of Methyl Acetate by Reactive Distillation Using Structured Catalytic Packings: Experiments and Simulation. *Ind. Eng. Chem. Res.*, **40**, 1566–1574.
- Pretel, E. J.; López, P. A.; Bottini, S. B. and Brignole, E. A. (1994). Computer-Aided Molecular Design of Solvents for Separation Processes. *AIChE J.*, **40**(8), 1349–1360.
- Process Systems Enterprise Ltd. (- 2001). *gPROMS User's Guide*. (www.psenderprise.com).
- Renon, H. and Prausnitz, J. M. (1968). *AIChE J.*, **14**, 135.
- Sargent, R. (1998). A Functional Approach to Process Synthesis and its Application to Distillation System. *Computers and Chemical Engineering*, **22**(1-2), 31–45.
- Schembecker, G. and Simmrock, K. (1995). Heuristic-Numeric Process Synthesis with PROSYN. *AIChE Symposium series*, **92**, 275–278.
- Schembecker, G.; Dröge, T.; Westhaus, U. and Simmrick, K. (1995). A Heuristic-Numeric Consulting System for the Choice of Chemical Reactors. *AIChE Symposium Series*, **91**, 336–339. Fourth International Conference on Foundations of Computer-Aided Process Design.
- Šeltinc, M. and Levec, J. (1999). On the Kinetics of Liquid-Phase Methanol Synthesis over Commercial Cu/ZnO/Al₂O₃ Catalyst. *Chem. Eng. Sci.*, **54**, 3577–3586.
- Sirola, J.; Powers, G. and Rudo, D. (1971). Synthesis of System Design III Toward a Process Concept Generator. *AIChE Journal*, **17**(3), 677–682.
- Silver Platter Information Inc. (1998a). Chemical Hazards Response Information System (CHRIS) Database. Electronic Database.
- Silver Platter Information Inc. (1998b). The Hazardous Substances Data Bank (HSDB). Electronic Database.
- Silver Platter Information Inc. (1998c). The Registry of Toxic Effects of Chemical Substances (RTECS). Electronic Database.
- Simulation Sciences Inc. (- 2000). Pro/II User's Manual.
- Smith, J. M. and Van Ness, H. (1987). *Introduction to Chemical Engineering Thermodynamics*. McGraw-Hill Int. Editions, New York, fourth edition.
- Soave, G. (1972). Equilibrium Constants from a Modified Redlich-Kwong Equation of State. *Chemical Engineering Science*, **27**, 1197–1203.

- Srinivas, B. and El-Halwagi, M. (1994). Synthesis of Combined Heat Reactive Mass-Exchange Networks. *Chem. Eng. Science*, **49**, 2059–2074.
- Syracuse Research Corporation (1998). SMILESCAS Database.
- Thompson, R. and King, C. (1972). Systematic Synthesis of Separation Systems. *AIChE Journal*, **18**, 941.
- Ung, S. and Doherty, M. (1995). Calculation of Residue Curve Maps for Mixtures with Multiple Equilibrium Chemical Reactions. *Ind. Eng. Chem. Res.*, **34**, 3195.
- Vaidyanathan, R. and El-Halwagi, M. (1994). Computer-Aided Design of High Performance Polymers. *Journal of Elastomers and Plastics*, **26**(3), 277–293.
- van Krevelen, D. W. (1990). *Properties of Polymers: Their Correlation with Chemical Structure; Their Numerical Estimation and Prediction from Additive Group Contributions*. Elsevier, Amsterdam, third edition.
- Vega, A.; Diez, F.; Esteban, R. and Coca, J. (1997). Solvent Selection for Cyclohexane-Cyclohexene-Benzene Separation by Extractive Distillation Using Non-Steady-State Gas Chromatography. *Ind. Eng. Chem. Res.*, **36**, 803–807.
- Venkatasubramanian, V.; Chan, K. and Caruthers, J. M. (1995). Genetic Algorithmic Approach for Computer-Aided Molecular Design. *ACS Symposium Series*, **589**, 396–414.
- Wahnschafft, O. (1997). Advanced Distillation Synthesis Techniques for Non-ideal Mixtures are Making Headway in Industrial Applications. *Institution of Chemical Engineers Symposium Series*, pages 613–623.
- Wahnschafft, O.; Rudulier, J. and Westerberg, A. (1993). A Problem Decomposition Approach for the Synthesis of Complex Separation Processes with Recycles. *Ind. Eng. Chem. Res.*, **32**, 1121–1141.
- Westerberg, A. and Wahnschafft, O. (1996). Synthesis of Distillation-Based Separation Processes. *Advances in Chemical Engineering*, **23**, 63–170.
- Widagdo, S. and Seider, W. (1996). Journal Review: Azeotropic Distillation. *AIChE Journal*, **42**, 96–130.
- Wilson, G. M. (1964). *J. Am. Chem. Soc.*, **86**, 127.
- Yee, T. and Grossmann, I. (1990). Simultaneous Optimization Models for Heat Integration – II. Heat Exchanger Network Synthesis. *Comp. Chem. Engng.*, **14**, 1165–1171.
- Yeomans, H. and Grossmann, I. (1999). A Systematic Modeling Framework of Superstructure Optimization in Process Synthesis. *Computers and Chemical Engineering*, **23**, 709–731.

- Yoshikawa, M. and Tsubouchi, K. (1999). Separation of Benzene/Cyclohexane Mixtures Through Poly(Vinyl Chloride)-Graft-Poly(Butyl Methacrylate). *Journal of Membrane Science*, **158**, 269–276.