



## System Integration of Distributed Energy Resources

**Nyeng, Preben; Østergaard, Jacob**

*Publication date:*  
2010

*Document Version*  
Publisher's PDF, also known as Version of record

[Link back to DTU Orbit](#)

*Citation (APA):*  
Nyeng, P., & Østergaard, J. (2010). System Integration of Distributed Energy Resources. Technical University of Denmark, Department of Electrical Engineering.

## DTU Library

Technical Information Center of Denmark

---

### General rights

Copyright and moral rights for the publications made accessible in the public portal are retained by the authors and/or other copyright owners and it is a condition of accessing publications that users recognise and abide by the legal requirements associated with these rights.

- Users may download and print one copy of any publication from the public portal for the purpose of private study or research.
- You may not further distribute the material or use it for any profit-making activity or commercial gain
- You may freely distribute the URL identifying the publication in the public portal

If you believe that this document breaches copyright please contact us providing details, and we will remove access to the work immediately and investigate your claim.

*Preben Nyeng*

# **System Integration of Distributed Energy Resources**

**ICT, Ancillary Services, and Markets**

PhD Thesis, July 2010



*Preben Nyeng*

# **System Integration of Distributed Energy Resources**

**ICT, Ancillary Services, and Markets**

PhD Thesis, July 2010

**System Integration of Distributed Energy Resources  
- ICT, Ancillary Services, and Markets**

**Author(s):**

Preben Nyeng

**Supervisor(s):**

Prof. Jacob Østergaard, Technical University of Denmark

**Funding:**

Technical University of Denmark

**PhD school:**

Department of Electrical Engineering, Technical University of Denmark

**Department of Electrical Engineering**

Centre for Electric Technology (CET)

Technical University of Denmark

Elektrovej 325

DK-2800 Kgs. Lyngby

Denmark

[www.elektro.dtu.dk/cet](http://www.elektro.dtu.dk/cet)

Tel: (+45) 45 25 35 00

Fax: (+45) 45 88 61 11

E-mail: [cet@elektro.dtu.dk](mailto:cet@elektro.dtu.dk)

---

Release date: TBD

Class: 1 (public)

Edition: 1

Comments: This report is a part of the requirements to achieve the PhD degree at the Technical University of Denmark.

Rights: © DTU Electrical Engineering, 2010

*Computing and communication are among the few things left in our society that are decreasing in cost.*

Fred C. Schweppe, M.I.T.



# ABSTRACT

---

Besides their primary product – electricity – large central power stations supply so-called ancillary services that are necessary to maintain a secure and stable operation state of the electric power system. As the need for electricity from these units is being displaced by renewable energy sources, this project aims at investigating how the ancillary services can be provided by others in the system, e.g. small generation units, and flexible demand.

The goal is a power system, where all units – small and large, producers and consumers – to the largest possible extent contribute to optimal system operation. It is therefore investigated in this project how ancillary services can be provided by alternatives to central power stations, and to what extent these can be integrated in the system by means of market-based methods.

Particular emphasis is put on automatic solutions, which is particularly relevant for small units, including the ICT solutions that can facilitate the integration. Specifically, the international standard "IEC 61850-7-420 Communications systems for Distributed Energy Resources" is considered as a possible brick in the solution. This standard has undergone continuous development, and this project has actively contributed to its further development and improvements.

Different types of integration methods are investigated in the project. Some are based on local measurement and control, e.g. by measuring the grid frequency, whereas others are based on direct remote control or market participation. In this connection it is considered how aggregation of many units into one logical entity, can make it possible for these units to provide ancillary services. As part of the investigations, operational, physical and thermodynamic models for e.g. micro-CHP and different types of flexible demand have been established. These models can be used for future investigations as well. A mixture of empirical and analytical methods have been used when defining the models and their parameters.

The project concludes that distributed energy resources, including flexible demand, can contribute significantly to optimal system operation by supplying ancillary services. Furthermore, the project shows concrete examples of possible, technical solutions to exploit this potential. In the project, information infrastructures and control methods to



realize the various concepts have been designed, implemented, and tested, including e.g. microcontroller systems for price- or frequency-responsive devices.

Looking ahead, demonstration projects in near future will hopefully be able to strengthen the confidence in the investigated control concepts. The experience gained, and the technical solutions developed in this PhD project can be utilized in such demonstration projects, and in a longer timescale contribute to forming the basis for further increase in the renewable energy sources penetration in the power system.

# RESUMÉ

---

## **Systemintegration af Decentrale Energiressourcer - ICT, Systemydelser og Markeder**

De store centrale kraftværker i elforsyningssystemet leverer foruden deres primære produkt, elektrisk energi, også en række systemydelser som er nødvendige for opretholdelse af en sikker og stabil driftssituation i systemet.

Idet behovet for energi leveret fra de centrale kraftværker i stadigt stigende grad fortrænges af vedvarende - oftest decentrale - energikilder, er det dette projekts formål at undersøge hvorledes systemydelserne kan leveres af andre aktører i systemet, f.eks. mindre decentrale produktionsenheder, og fleksibelt elforbrug.

Målet er et elforsyningssystem hvor alle enheder - store og små, producenter og forbrugere - i videst muligt omfang bidrager til en optimal drift af systemet. Det undersøges hvorledes systemydelser kan leveres fra alternativer til de centrale kraftværker, samt i hvilket omfang disse kan systemintegreres ved hjælp af markedsbaserede principper.

Der er særlig fokus på automatiserede løsninger, som er særligt relevante for små aktører, herunder de ICT-løsninger der skal facilitere integrationen. Konkret undersøges den internationale standard "IEC61850-7-420 Communications systems for Distributed Energy Resources (DER)" som en del af løsningen. Dette er en standard som er under løbende udvikling og projektet har bidraget aktivt til at videreudvikle og forbedre den.

Der undersøges dels metoder der baserer sig på lokal måling og styring på baggrund af f.eks. netfrekvens, dels metoder der baserer sig på direkte fjernstyring eller deltagelse i markeder. Herunder undersøges det hvorledes aggregering af mange enheder i en logisk enhed kan muliggøre levering af systemydelser. I forbindelse med undersøgelserne opstilles operationelle, fysiske og termodynamiske modeller af bl.a. mikrokraftvarme og forskellige former for fleksibelt elforbrug. Disse modeller kan bruges fremadrettet i yderligere undersøgelser. Der er anvendt en blanding af empiri og analytiske metoder i modeldannelsen.

Projektet konkluderer at decentrale energiressourcer inklusiv fleksibelt forbrug kan bidrage væsentligt til opretholdelse af systemets optimale drift ved levering af systemydelser, og projektet viser konkrete eksempler på mulige, tekniske løsninger for

udnyttelse af dette potentiale. I projektet er der designet, implementeret og testet informations-infrastrukturer og decentrale styringsmetoder der muliggør at dette potentiale kan aktiveres, herunder f.eks. mikrocontroller-baserede styringsenheder til pris- eller frekvensstyrede DER.

Fremadrettet vil nært forestående demonstrationsprojekter forhåbentligt øge tiltroen til de undersøgte koncepter. De i dette projekt opnåede erfaringer og udviklede løsninger vil konkret kunne udnyttes i sådanne projekter, og på længere sigt kan projektets resultater bidrage til den teknologiske grobund for yderligere udbygning med vedvarende energi i elforsyningen.

# CONTENTS

---

<b>Abstract .....</b>	<b>7</b>
<b>Resumé.....</b>	<b>9</b>
<b>Contents.....</b>	<b>11</b>
<b>List of Publications .....</b>	<b>13</b>
<b>Abbreviations .....</b>	<b>15</b>
<b>1 Introduction .....</b>	<b>17</b>
1.1 Background .....	17
1.2 Local, Remote and Market-Based Control.....	18
1.3 Report Structure .....	19
1.4 Project Resources .....	19
1.5 Related Work.....	20
<b>2 DER Integration .....</b>	<b>23</b>
2.1 DER in the Danish Power System.....	23
2.2 The Nordic Power Markets .....	25
2.3 Ancillary Services Definitions and Requirements .....	29
2.4 Communication .....	33
<b>3 Results .....</b>	<b>35</b>
3.1 Reactive Power and Voltage Control in Distribution Grids.....	35
3.2 LFC (Regulation) Provided by Coordinated Control of Multiple Distributed Resources.....	38
3.3 Control-by-Price.....	39
3.4 Demand as Frequency-controlled Reserve.....	41
<b>4 Discussion and Conclusion .....</b>	<b>43</b>
4.1 Control-by-price Challenges .....	43
4.2 Market-based Reactive Power Control.....	47
4.3 Other Ancillary Services Remuneration.....	49
4.4 "The Super-Market" .....	50
4.5 Aggregation vs. Market-based Control .....	51

Contents

---

4.6	Communication.....	51
4.7	Conclusion .....	52
	<b>References .....</b>	<b>55</b>
<i>A</i>	<b>Reactive Power Control With CHP Plants - A Demonstration .....</b>	<b>59</b>
<i>B</i>	<b>Communication Systems for Distributed Energy Resources - A Demonstration of IEC 61850-7-420 .....</b>	<b>69</b>
<i>C</i>	<b>Coordinated Multi-Objective Control of Regulating Resources in Multi- Area Power Systems with Large Penetration of Wind Power Generation .....</b>	<b>83</b>
<i>D</i>	<b>Information and Communications Systems for Control-by-Price of Distributed Energy Resources and Flexible Demand.....</b>	<b>91</b>
<i>E</i>	<b>Design and Implementation of Frequency-responsive Thermostat Control .....</b>	<b>101</b>
<i>F</i>	<b>Modeling and Simulation of Power System Balancing by Distributed Energy Resources and Flexible Demand .....</b>	<b>109</b>

## LIST OF PUBLICATIONS

---

The following papers have been written as part of this PhD project.

Papers A to F contain the main results of the project, and are included in appendices.

Papers from G onwards contain minor contributions from the author, or contributions that are already covered in papers A to F.

- [A] Preben Nyeng, Jacob Østergaard, Claus A. Andersen, Jacob Dall, Carsten Strunge, "Reactive power control with CHP plants - A demonstration", CIGRE Session, 2010 (accepted)
- [B] Preben Nyeng, Jacob Dall, Claus A Andersen, "Communication Systems for Distributed Energy Resources - A Demonstration of IEC 61850-7-420", *Computer Standard & Interfaces* (submitted)
- [C] Preben Nyeng, Bo Yang, Jian Ma, Yuri Makarov, John H. Pease, David Hawkins, and Clyde Loutan, "Coordinated Multi-Objective Control of Regulating Resources in Multi-Area Power Systems with Large Penetration of Wind Power Generation", In: PROCEEDINGS - 7th International Workshop on Large-Scale Integration of Wind Power into Power Systems : 26-27 May, 2008, Madrid, Spain
- [D] Preben Nyeng, Jacob Østergaard, "Information and Communications Systems for Control-by-Price of Distributed Energy Resources and Flexible Demand", *IEEE Transactions on Smart Grid* (submitted)
- [E] Preben Nyeng, Jacob Østergaard, Mikael Togeby, János Hethey, "Design and Implementation of Frequency-responsive Thermostat Control", 45th International Universities' Power Engineering Conference 2010 (accepted)
- [F] Preben Nyeng, Jacob Østergaard, "Modeling and Simulation of Power System Balancing by Distributed Energy Resources and Flexible Demand", *IEEE Transactions on Power Systems* (submitted)

- [G] Donghan Feng, Preben Nyeng, Jacob Østergaard, Jin Zhong, "New Real-time Market Facilitating Demand-side Resources for System Balancing", *IEEE Transaction on Industrial Electronics, Special Section on Methods and Systems for Smart Grids Optimization* (submitted)
- [H] Yuri V. Makarov, Bo Yang, John G. DeSteeese, Preben Nyeng, Carl H. Miller, Jian Ma, Shuai Lu, Vilayanur V. Viswanathan, Donald J. Hammerstrom, Bart McManus, John H. Pease, Clyde Loutan, Grant Rosenblum, "Wide-Area Energy Storage and Management System to Balance Intermittent Resources in the Bonneville Power Administration and California ISO Control Areas", In: Proceedings of 8th International Workshop on Large-Scale Integration of Wind Power into Power Systems, 2009
- [I] Bo Yang, Yuri Makarov, John Desteese, Vilayanur Viswanathan, Preben Nyeng, Bart McManus, John Pease, "On the Use of Energy Storage Technologies for Regulation Services in Electric Power Systems with Significant Penetration of Wind Energy", In: 5th International Conference on the European Electricity Market : IEEE conference proceedings, 2008
- [J] Preben Nyeng, Knud O.H. Pedersen, Jacob Østergaard, "Ancillary Services From Distributed Energy Resources – Perspectives For the Danish Power System", IYCE 2007 conference, 2007

## ABBREVIATIONS

---

BRP	Balance Responsible Party
CBRP	Consumption Balance Responsible Party
CHP	Combined Heat and Power
CIM	Common Information Model
DER	Distributed Energy Resource
DFR	Demand as Frequency-controlled Reserve
DSO	Distribution System Operator
ICT	Information and Communication Technology
LFC	Load-Frequency Control
LMP	Locational Marginal Pricing
MMS	Manufacturing Message Specification
OPF	Optimal Power Flow
PBRP	Production Balance Responsible Party
RP	Regulating Power
TSO	Transmission System Operator
UCA	Utility Communications Architecture
VPP	Virtual Power Plant
WAEMS	Wide Area Energy Storage and Management System





# 1

## INTRODUCTION

---

### **1.1 Background**

Since the 1980s the propagation of distributed generation in the Danish power system has increased from being negligible to represent more than 40% of the total electric power consumption [1]. In the beginning of this process, these generation units could operate without concern for the impact on the power system. There were simply too few of them to impact system operation. However, with the increasing propagation of distributed generation, controlling these units in a more rational way becomes likewise more important.

The central power plants deliver not only the electric power but also a set of ancillary services to support the power system operators in their effort to keep the power system in a secure and appropriate state of operation. Since the electric energy delivered by central power plants is being increasingly displaced by the distributed generation, whilst the central power plants are still needed to supply ancillary services, pressure is put on finding alternative solutions for the ancillary services as well.

In addition, the need for some ancillary services is likely to increase with the expected future development towards a power system based on renewable energy sources. These are often intermittent, which means that the need for available ancillary services for balancing purposes is increased. In 2008, the Danish TSO published the results of an extensive survey of methods that could make it possible to meet the ambitious goal of 50% wind energy in the Danish power system [2]. Above all, this report concludes that increased availability of resources for power system balancing is going to be critical. This further provides the motivation for activating any available asset that can contribute, and a significant part of this PhD project is focused on this very topic.

With potentially decreasing supply and increasing demand for ancillary services, scarcity and increasing costs is a likely scenario. It is therefore important that all potentially available resources are brought into play, and many types of DER can indeed provide ancillary services. However, present market and organizational structure prevents an efficient integration and utilization of this potential, and it is therefore the overall purpose with this project to investigate how future integration strategies for DER can exploit their potential to contribute to efficient system operation.

No rigorously limited definition of distributed energy resources (DER) is used in this report. However, the project is focused on technologies that have the ability to provide ancillary services, and for which efficient integration methods have not been fully developed, or not developed at all. Demand that can be controlled in a way so that it supports system operation is an important resource in the future power system, and hence included in the scope of DER throughout this report. Examples of DER include combined heat and power (CHP) plants from district heating size, down to household-sized micro-CHP units, storage devices like flywheels, and flexible demand like electric space heating.

The approach used is based on the rationale that existing assets, or assets that would be installed regardless of the need for ancillary services, can be utilized better by improving system integration with respect to a higher information level, and increased controllability. In particular, the project focuses on information and communication technology that can facilitate the integration, and new market concepts that can assure an efficient resource allocation.

In the project, several specific control concepts have been investigated. Generally, a mixture of modeling and simulations, field tests, and laboratory tests, has been used to verify the concepts.

### ***1.2 Local, Remote and Market-Based Control***

Throughout this report, the application of different control concepts to DER is investigated. A general way of categorizing these control concepts is by dividing them in local, remote, or market-based control concepts (a more detailed description of specific concepts is given in section 2.3).

In a local control concept, a physical quantity is measured by the DER, and the DER performs control actions based on this measurement. In this category belongs for example the so-called droop control, in which the DER controls its power exchange with the grid as a function of the locally measured frequency. Since the control loop is completely local, this allows for a very fast response.

In a remote control concept, the DER is controlled from remote to take certain actions. Compared with local control concepts, this allows for an aggregate or even system-global coordination of control measures. In this category belongs for example load-frequency control (LFC) in which the power balance within a control area is maintained by centrally coordinated real-time dispatch of generation.

Finally, market-based control is a category somewhere in between. It can work in different ways, but is often a hybrid of local and remote control. On the one hand, the purpose of the market is to coordinate many resources, and the decision-making is in that sense remote, but on the other hand, there is no direct remote control over specific units, as it is up to each unit to decide its own strategy in the market, and thereby its willingness to perform a certain action, e.g. ramp up, for a certain price. Compared with

the local and direct remote control concepts, this type of control will normally have a significantly longer timeline.

### 1.3 Report Structure

The main results of the project are published in separate scientific papers. Totally 6 papers are included in appendices A through F. The papers are referenced throughout this report as needed, but may also be read independently of this report.

This first chapter of the report introduces the overall problem and the reasoning behind the project. The second chapter provides necessary background information regarding ancillary services, ICT, and markets. Next, the papers are summarized in a chapter with four subsections, that each contains a case study of a certain application. Each case study is limited in scope to a certain type of ancillary service and/or a certain type of DER ancillary services provider. These can be read in any order, as they do not depend on each other, but the ordering chosen in this report is based on the distinction made between remote, market-based, and local control concepts. An overview of the cases, the category and topic they cover, and the referenced papers is given in Table I.

Finally, the discussion and conclusion chapter connects the preceding case studies, linking them into a broader context, and outlines future paths to follow in the constant striving for optimal system integration of DER.

TABLE I  
REPORT RESULTS OVERVIEW

Section	Category	Topic	Primary scope	Papers
3.1	Remote	Reactive power control	District heating CHP	A,B
3.2	Remote	LFC	Fast-responding units, e.g. online generation and storage	C
3.3	Market-based	Real-time price signals	Small-scale generation and flexible demand	D,F
3.4	Local	DFR	Flexible demand	E,F

### 1.4 Project Resources

Except for the external contributions mentioned below, this report, including the attached papers, is a result of the author's original work.

The case study in section 3.1 was conducted in connection with the NextGen project, funded by the Danish TSO Energinet.dk. The overall purpose of the NextGen project was to get first-hand experience with the – at that time – upcoming communication standard IEC 61850-7-420 for DER. Communication according to the standard draft was implemented by NextGen project participant EURISCO for a district heating CHP

plant. This implementation formed the test platform for the control concept described in the case study.

The case study in section 3.2 was performed when the author was a visiting researcher at the Pacific Northwest National Laboratory (PNNL), Washington, USA. Consequently, it is developed in the context of the power system there, and within an already established project at PNNL, the Wide Area Energy Storage and Management System (WAEMS), funded by the Bonneville Power Administration.

Finally, the thermodynamic model of residential homes was developed by M.Sc. student Casper Mieritz. The author utilized this model in the simulations in paper F.

### **1.5 Related Work**

In 1978, Schweppe published an article about the future power system [3]. It was a vision about a power system with many distributed energy resources, and a system where customers would play an important role for the operation of the power system. This would be possible with the prevalence of low cost electronics and information and communication technology that would provide more or less pervasive processing power and a high level of automation. Later, he and his colleagues published a more technical paper on these ideas [4], whose main contribution was the proposal of price-responsive and frequency-responsive demand. Parts of this PhD work is based on these original ideas, and focused on paths for realization. By implementing and testing these concepts in the laboratory, and further modeling and simulating them in a larger scale, possible tracks to follow for a future implementation are outlined.

More recently, other research and industrial efforts have looked into some of the topics that are covered in this report. Among the most remarkable is the American GridWise initiative, that has demonstrated demand response controlled by prices and frequency [5],[6]. This PhD project has been using many ideas from this work, which have been elaborated and improved.

The overall idea of improving the automation level, and particularly in distribution systems, is generally attracting a lot of focus these years. The overall label for these activities is Smart Grids, and several projects look into different aspects of this. The Smart-A project [7] focuses on demand response for consumer appliances, and analyses potentials and barriers. Larger projects like ADDRESS [8] provide an ICT concept for aggregation of distributed generation and demand, and focuses on the real-time balancing of demand and supply.

Compared with these and other projects, the focus in this PhD work is based on a bottom-up approach where detailed physical and thermodynamic models of DER lead to answers about the overall impact on the power system. This approach is chosen to be able to investigate the dynamic behavior of these concepts, and thereby its ability to participate in system operation, and reduce the need for conventional methods.

Furthermore, the above projects are mainly focused on energy supply, markets, and business-cases, and less on the ancillary services like frequency control and reactive power support. In this PhD work, the applicability of DER for ancillary services is studied in a broader and more comprehensive sense.

Finally, aggregation of DER appears to be the prevailing integration strategy in most ongoing and recent activities. In this PhD project there are indeed examples of aggregation, but alternative solutions, like DER participating directly in markets, are investigated as well.

With regards to communication, the Electric Power Research Institute (EPRI) provided the foundation for the object-oriented approach to information modeling in the now well-established IEC 61850 communication standard [9]. The use of this standard for DER has been developed by a dedicated working group in IEC, and this PhD project has validated the extension for DER and provided feedback and recommendations for changes to the IEC working group.

Controlling CHP plants through aggregation was investigated in the Danish PUDDEL project prior to this PhD project [10]. The purpose in the PUDDEL project was to integrate smaller CHP plants in the Nordic regulating power market by aggregating them. This project was quite successful and its methodology and results have been a direct inspiration for the idea about reactive power control investigated in section 3.1.



# 2

## DER INTEGRATION

---

### ***2.1 DER in the Danish Power System***

The Danish power system is divided in two separate synchronous areas, the western (DK1) being part of the continental European system (formerly UCTE) and the eastern (DK2) being part of the Nordic system (formerly Nordel). In Fig. 1 a map of Denmark with the two areas indicated is shown. There is currently no direct link between the two parts of the system, but HVDC connections from DK1 to Norway and Sweden and from DK2 to Germany, make energy transfers possible. Furthermore a direct HVDC link between DK1 and DK2 is under construction and will be commissioned in 2010.

In Table II an overview of peak loads and installed production capacity for the areas is given. It is clear that in the DK1, the propagation of distributed generation is much more extended than in DK2. For the wind turbines it is caused by the wind potential being much higher along the western shore, and for the decentralized CHP plants it is caused by the large number of small towns in DK1, that are suitable for small-scale district heating.



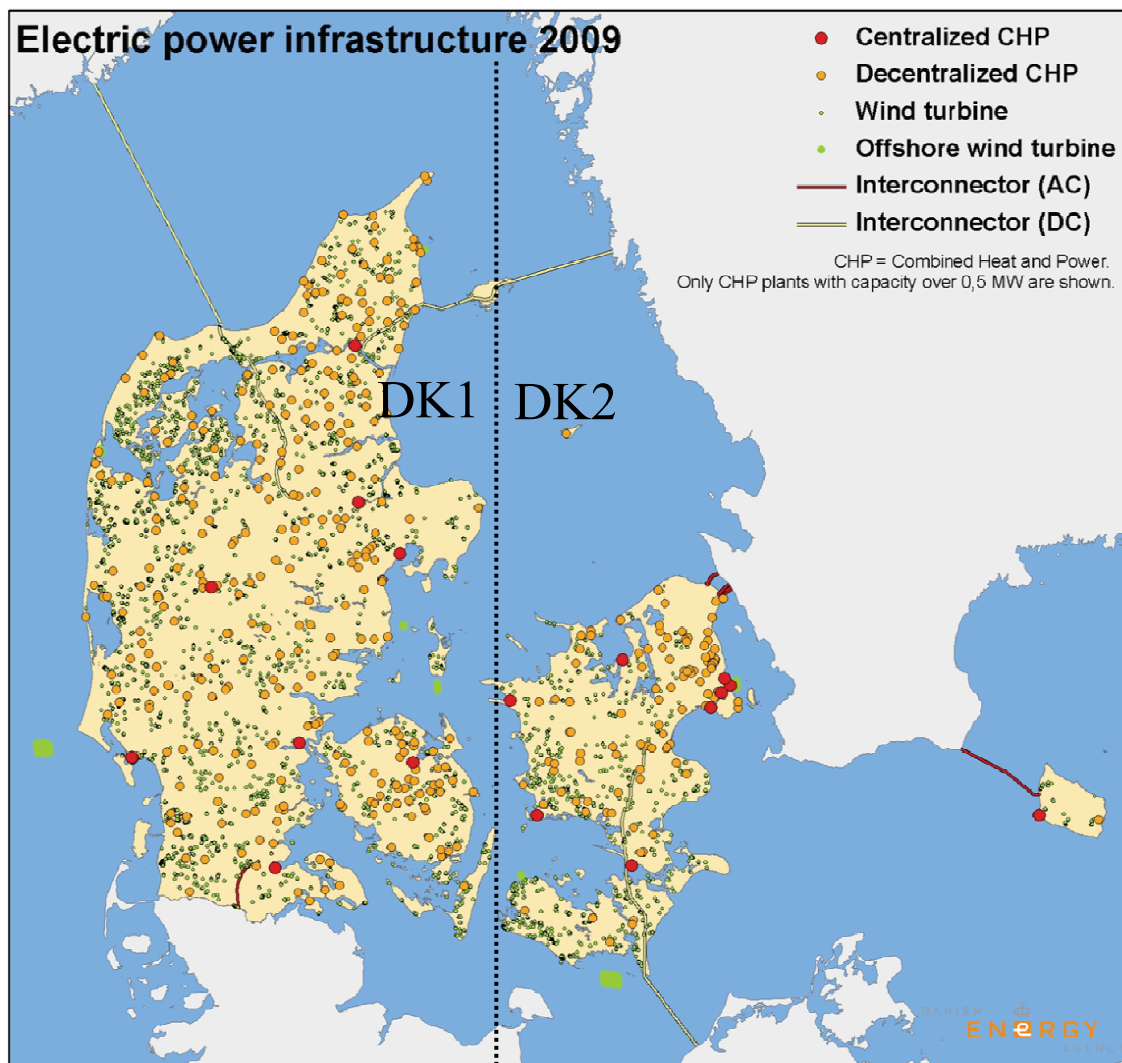

Fig. 1. Energy map of Denmark and the synchronous systems.

TABLE II  
CAPACITY AND DEMAND IN THE DANISH POWER SYSTEM

	DK1 / West	DK2 / East
Peak load	~3,650 MW	~2,700 MW
Central power plants	4,057 MW	4,328 MW
Decentralized CHP plants	1,124 MW	399 MW
Wind turbines	2,393 MW	735 MW

Peak loads are typical winter day peaks. [11]-[13].

Because most of the currently installed wind turbines are of the "Danish concept" type, i.e. equipped with a directly grid-connected induction generator with limited or no control opportunities, they are not capable of supplying ancillary services. However, since any new installation must comply with the latest grid codes, including real and reactive power control, there may be a potential for ancillary services from wind turbines in the future.

In contrast, the decentralized CHP plants are most commonly equipped with synchronous generators, driven by gas engines (piston engines) or gas turbines, making them very flexible and suitable for providing ancillary services.

In Table III an overview of the decentralized CHP production capacity is given, grouped by size. The lower limit of 1.5 MW is chosen because the transmission system operator Energinet.dk has different grid codes for plants above or below 1.5 MW [14].

The figures show that in DK1 the largest capacity is represented by small and medium-sized plants (< 25 MW) whereas most of the capacity in DK2 is concentrated on a few larger plants (> 25 MW).

TABLE III  
DECENTRALIZED CHP PLANTS IN DENMARK

Plant capacity	DK1 / West		DK2 / East	
< 1.5 MW	96	87 MW	12	9 MW
1.5 MW – 10 MW	126	481 MW	21	73 MW
10 MW – 25 MW	15	223 MW	6	72 MW
> 25 MW	6	333 MW	5	244 MW

Figures from [11]. Capacities are electric power capacities. Values are expressed as number of plants as well as aggregate production capacity.

## 2.2 The Nordic Power Markets

The Nordic power system is to a large extent deregulated, and each player in the system has well defined and well isolated roles. The most important players in relation to the market are:

- Balance responsible parties, BRPs. There are separate BRPs for consumption (CBRPs), and production (PBRP). The BRPs are not responsible for the system balance, but are financially responsible for their clients' consumption or production of electricity. Every individual consumer or producer must have a BRP, who trades the electricity for them and handles the financial obligations related with the electricity markets (in principal everyone can act as their own BRP, but it requires a certain size, due to lower limits in the bids, collateral obligations, administration overhead etc.).
- Transmission and distribution system operators (TSOs and DSOs). These are regulated, natural monopolies that operate and usually own the physical power

lines. In addition, the TSOs have the overall system responsibility, which includes maintaining the system-wide continuous balance between production and consumption. The DSO's role in relation to the market, is metering, and forwarding of the meter readings for end-user settlements. In addition, the TSOs as well as the DSOs, purchase the energy lost in their respective grids in the market.

The market architecture consists of several forward markets with different time scale:

- Financial bilateral contracts, traded months or years ahead.
- The day-ahead power exchange Elspot. This is the main coordinating Nordic market. It is a uniform price double auction with implicit auctioning of transmission capacity. The market establishes an equilibrium price (possibly offset in predefined price zones) for each hour in the following day of operation.
- The intra-day market Elbas. This is a pay-as-bid bilateral market place, where power contracts can be traded up to one hour before the beginning of the hour of operation. Congestion is handled by a first-come, first-served policy. Elbas was introduced to let market players with forecast errors – typically wind power – adjust their schedule as the hour of supply approaches, hopefully with less financial penalty than they would have otherwise suffered. However, Elbas does not attract sufficient market players to be considered liquid.
- The regulating power market (RP market). This market is a uniform price auction with the TSO as a single buyer that accepts bids continuously during each hour, to maintain the system's energy balance. Bids must be submitted no later than 45 minutes before the start of each hour of operation. All bids are sorted by price, and the best bids are accepted first, that is the ones with the lowest price for up regulation (TSO is buying energy, i.e. more production or less consumption), and the highest price for down regulation (TSO is selling energy). Fig. 2 illustrates this process. For each hour, marginal up and down regulation prices are determined and applied accordingly to all accepted bids, however like in Elspot, congestion may lead to different prices in each price zone.

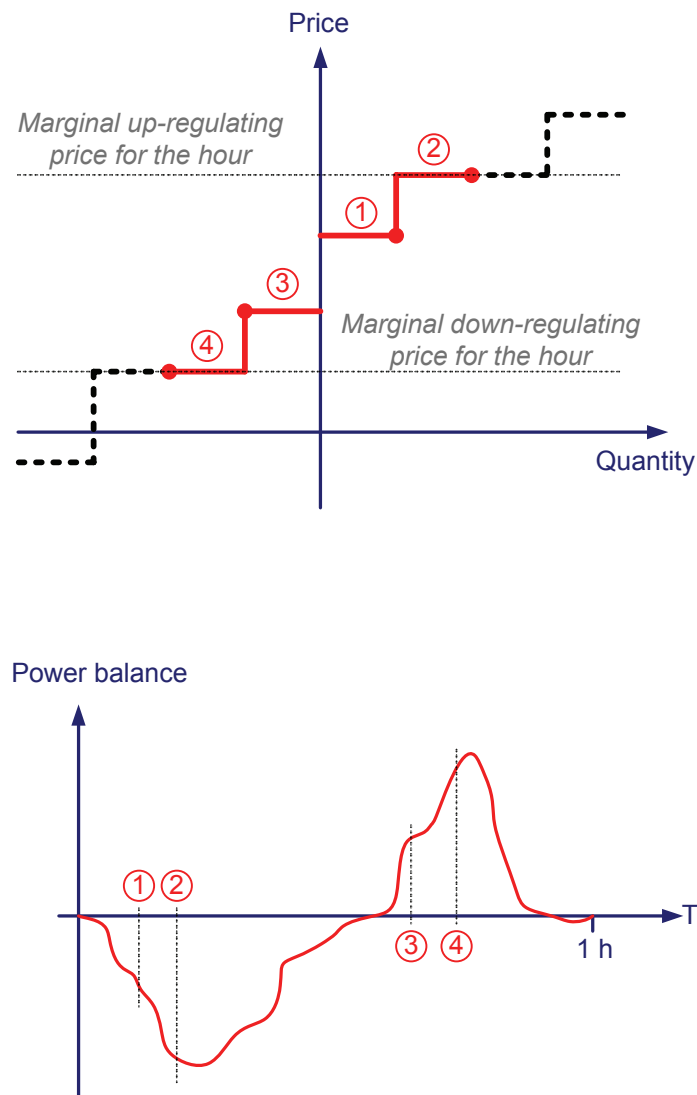

Fig. 2. Regulating power market bids and ordering (top), and acceptance of numbered bids during a single hour (bottom). As the demand for regulating power changes during the hour, bids are accepted to neutralize imbalances. When a negative imbalance occurs (energy deficit), up-regulating bids are accepted, which results in more production or less consumption. Vice-versa for a positive imbalance (energy surplus), where down-regulating bids are accepted.

### 2.2.1 Real-time pricing

The Nordic market architecture uses a multi-settlement system, in which the first settlements are based on the outcome of the forward markets, and the final settlement takes place in or after each hour of operation. The quantities in the final settlement are calculated as any difference between the schedules and the actual quantities of energy produced or consumed. The price in the final settlement is referred to as the real-time price, because it is based on the actual supply and demand situation at the point in time where the energy is actually supplied to the customer (in contrast to e.g. the day-ahead contract price that is based on prognoses) [15].

The present Nordic market architecture does not formally include a common real-time market, although only minor differences remain after recent harmonization [16], [17]. The basic structure is similar in all the Nordic countries. Based on bilateral trades, and forward contracts from Elspot, Elbas and the RP market, a schedule for each market player is put together. Deviations from these schedules are called *imbalances*, and are by definition compensated for by buying or selling *balance power*.

The *balance power* price (or real-time price) is based on the outcome of the RP market. The predominant regulation direction in the RP market, i.e. the direction with the largest accepted quantity, defines the hour as either an up or down regulation hour, and the *RP price* for the hour is accordingly defined as the marginal price for up or down regulation, respectively. In hours with no accepted bids in the RP market, the RP price is defined equal to the Elspot price.

With the RP price known, there are two different ways of determining the actual real-time price for each market player: The one-price and the two-price models. In the one-price model, there is one single price for buying and selling electricity in the real-time market, and it is always equal to the RP price. In the two-price model, there is a separate price for buying, and another for selling. The buying price is the highest of the Elspot price and the RP price, and the selling price is the lower of the two. It means that for example in hours with an energy deficit, where there is a need for up regulation and therefore an RP price that is higher than the Elspot price, market players who consume more than contracted for – or produce less – will buy the difference in the real-time market at the RP price, whereas those who do the opposite, consume less or produce more, will only be paid the Elspot price [18]. Consequently, the real-time prices for market participants under the two-price system will generally be less attractive than the Elspot price. In Fig. 3 this is quantified with historic real-time prices, relative to day-ahead Elspot price.

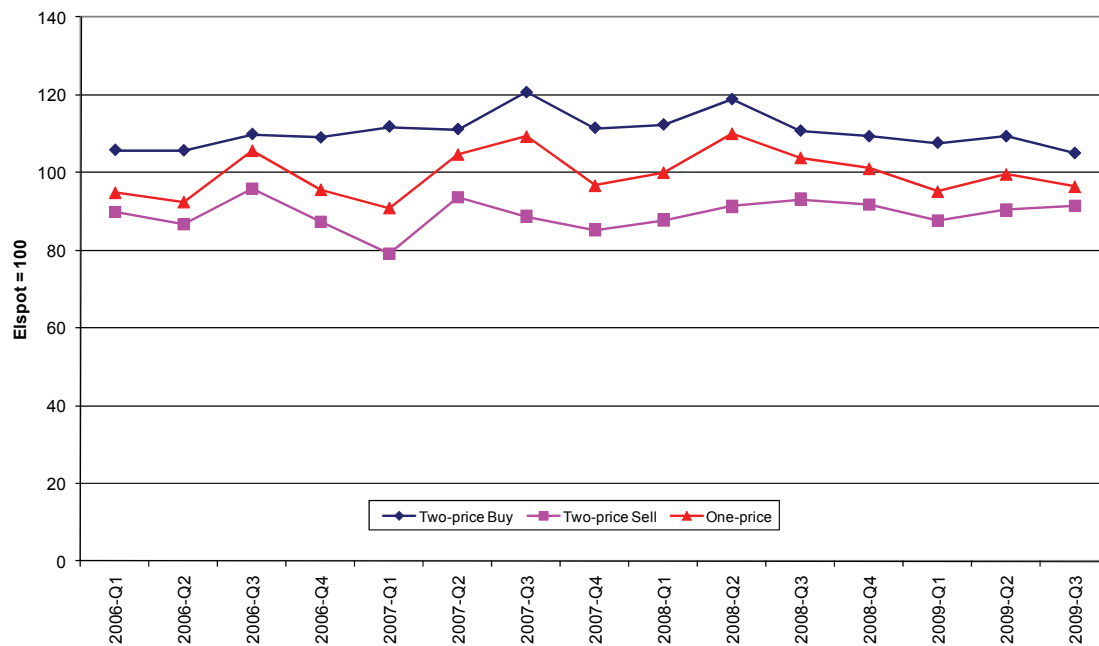

Fig. 3. Real-time market prices relative to the Elspot prices, for the price zone DK1 in 2006 to 2009. Based on data from [19]. Prices are mean values over one quarter.

The use of two-price versus one-price models has been discussed in the Nordic countries, and has been one of the major differences between the Nordic real-time markets, with for example Denmark using the two-price model, and Norway the one-price model. However, as of January 2009, the Nordic TSOs agreed on harmonizing their markets, so that all the Nordic countries now use the one-price model for consumers (CBRPs) and the two-price model for producers (PBRPs) [17].

It means that power producers have an incentive to trade as much as possible in the day-ahead and RP markets and avoid real-time trades by complying with the schedules. On the other hand, consumers that are settled using the one-price model, on average seem to be leveled out financially, so trading in the day-ahead market is mostly about hedging the risk of price spikes, that are more likely to occur in the real-time market.

Though the real-time price is determined after each hour in which it is valid, the principles for setting it affects the real-time behavior of market participants, and thereby directly or indirectly affects the overall system operation. In that sense, the real-time pricing scheme is to be considered in the gray area between electricity markets and ancillary services, and as it will be discussed in section 4.1, the consequences of the two-price model must be considered in connection with market-based active power control.

### 2.3 Ancillary Services Definitions and Requirements

Many different definitions of ancillary services exist, and the definitions and requirements are slightly different from power system to power system. References [20] and [21] together provide an excellent overview of ancillary services definitions in

different countries, and in the following, the requirements for ancillary services are described in more detail for the Danish context. The section provides an overview of the ancillary services currently requested by transmission or distribution system operators. The separate areas DK1 and DK2 must each be operated in compliance with the synchronous systems they are part of, specified in the *UCTE Operational Handbook* [22] and the *Nordel System Operation Agreement* [23], respectively.

Due to these constraints the conditions for some of the ancillary services are slightly different in the two systems, however the fundamental principles and the applicability to DER are the same. The ancillary services that the system operators demand are essentially about control, and as mentioned in section 1.2 this report divides the control concepts in local, remote, and market-based control. Furthermore the ancillary services considered in this project can be divided in controlling either the system frequency or voltage, by active power or reactive power control actions, respectively. In addition to these, there are ancillary services for e.g. black-start capability, and must-run agreements with power plants to provide inertia and short-circuit power to ensure system security. These are however beyond the scope of this project.

### 2.3.1 Local active power control

In a situation where an imbalance between generation and load results in a deviation of the system frequency from the nominal frequency, the primary control action is to adjust the power generation based on a local measurement of the actual frequency.

This is implemented as a proportional controller at each generator, often referred to as a droop controller. In Fig. 1 the relation between frequency deviation and control action for a droop controller is shown.

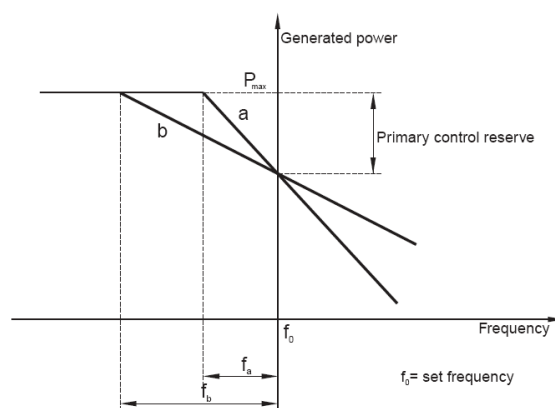

Fig. 1. Sketch of two different droop controller characteristics. From [22].

In DK1, the frequency-controlled reserves are simply called the primary reserve, and must supply a total of  $\pm 32.1$  MW (upward or downward) regulation, calculated as a relative fraction of the entire UCTE area, which requires  $\pm 3,000$  MW primary control reserves. The control response must be delivered linearly with a frequency deviation of

0.2 Hz, within 15 seconds for a 50% response and within 30 seconds for a 100% response [22].

In DK2, there are two different kinds of frequency-controlled reserves: The *frequency-controlled normal operating reserve* and the *frequency-controlled disturbance reserve* [23]. The *normal operating reserve* is for maintaining the system frequency at a reasonable level during normal operation, i.e. to compensate for minor deviations in the expected production or consumption. It must be fully activated at a frequency deviation of 0.1 Hz, with a maximum time delay of 2-3 minutes. DK2 is obliged to provide  $\pm 23$  MW regulation for this purpose, out of a total requirement for the Nordel area of  $\pm 600$  MW.

The *frequency-controlled disturbance reserve* must compensate for any sudden loss of production, and it is therefore only an upward regulation (emergency block islanding on selected power stations is used for downward regulation). It must be delivered linearly with a frequency drop between 0.1 Hz and 0.5 Hz, with a maximum time delay of 5 seconds for 50% of the required control response and 30 seconds for the total response. Automatic frequency-dependant load-shedding may be considered a disturbance reserve. The Danish system must supply 168 MW of frequency-controlled disturbance reserve to the Nordic system, which in total requires 1,160 MW. In Fig. 4 the control responses of the two kinds of frequency-controlled reserves are illustrated.

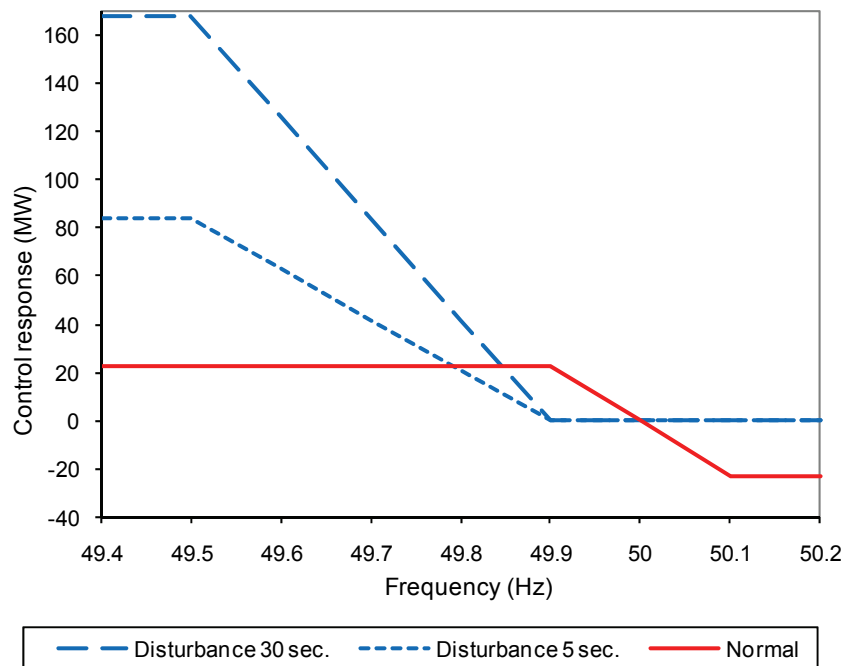

Fig. 4. Illustration of the control responses from frequency-controlled normal and disturbance reserves.

DER may provide the frequency-controlled reserves, e.g. district heating CHP plants. However this could cause a problem in periods where these units are not online. Due to reliability reasons, it is therefore preferable to distribute the task on many



devices rather than few, and in this project focus is put on flexible demand to provide the frequency-controlled reserve, which is further described in section 3.4.

### 2.3.2 Remote active power control

Due to the characteristics of the frequency-controlled reserves, additional control actions must take place to compensate the steady-state error from the proportional droop control. These reserves are not directly frequency-controlled and are activated from remote by automatic or manual dispatch.

In DK1 an LFC system is used to automatically control selected generators. The reserves activated by this controller are hence called *automatic regulating reserves*. The requirements for these are ambiguously defined. The Danish TSO requires that the control response from providers of this service must be fully active within 15 minutes after the activation signal has been sent from the control center [24]. However, the UCTE requirements state that the overall LFC controller after a disturbance must restore system frequency to its nominal value, and net tie line exchange to the scheduled values within 15 minutes without overshoot [22]. This would probably require faster response from the participating units than indicated by the Danish TSO.

At least  $\pm 90$  MW is currently reserved for automatic regulation in DK1, with the possibility to increase the amount depending on particularly wind forecasts [24].

In DK2 there is no LFC system. The minute-by-minute balance is instead handled by the frequency-controlled normal operation reserve, which in turn is relieved by the manual regulation as needed (cf. section 2.3.3).

The LFC system is designed for dispatch of large generators, and does not fit well with the distributed nature of DER. Therefore, aggregation may be a way for DER to provide LFC, which is investigated in section 3.2.

### 2.3.3 Market-based active power control

In addition to the local and remote control concepts described in the previous sections, market-based control is used to level out any residual error, and restore the mentioned reserves. The system operator may choose to dispatch up or down regulation based on several criteria, e.g.:

- frequency-controlled or LFC reserves being close to its control limits
- power exchange with neighboring power systems exceeding acceptable limits
- the integral of the frequency error exceeding acceptable limits

This control concept is called *manual regulation*. It is based on the regulating power market, described in section 2.2. The system operator selects the most attractive bids as control actions become necessary, and informs the bidders that their bids have been selected – this process is called activation of bids. There must be a maximum time delay

of 15 minutes from the request from the control centre has been sent to the reserve is fully active.

A number of limitations and requirements in this setup makes it infeasible for small-scale DER, even though many DER units could provide the fundamentally underlying service. An alternative solution is investigated in section 3.3.

### **2.3.4 Reactive power control**

Reactive power is controlled on few selected power plants, that maintain the voltage in certain locations in the transmission system. In that sense, the control is local, as the power plants measure the voltage locally, and adjust the reactive power injection or uptake accordingly. However, the voltage setpoint for the local control may be set remotely by the TSO depending on the grid condition. In addition to this, the TSO can operate various reactive power compensation devices to secure the voltage profiles.

These are all resources that are located in the transmission system, where DER is rarely connected. This does not leave much opportunity for DER to provide reactive power services. However, the Danish TSO has also introduced limitations in the allowed exchange of reactive power between the transmission system and distribution grids (the so-called *Mvar-arrangement*), meaning that DSOs must compensate the reactive power within the distribution grid. This in turn increases the need for reactive power control in the distribution grids, and DER may provide this, as described in section 3.1.

## **2.4 Communication**

For remote control concepts to work, an information exchange link must be established between the controller and each DER unit. For efficient integration these must use standardized information and communication standards, and Table IV shows a compressed overview of standards that have been considered for this project.

The general need for increased distribution automation, including information and communication services, led to the Electric Power Research Institute (EPRI) starting working on the Utility Communications Architecture (UCA) in the 1980s. Version 2.0 of the UCA was published in 1999 as an IEEE Technical Report [9], and subsequently, UCA formed the foundation for the now established international standard IEC 61850. It contains an object-oriented approach to information modeling, which in short removes focus from bits and bytes, and raises the abstraction level.

IEC 61850 was later supplemented with extensions of the information modeling classes. In particular the extension for DER has been investigated in this project, and more details and an implementation approach is described in paper B.

In parallel with UCA, EPRI started their work on a high-level control center information exchange format. It was initially developed as part of the Control Center Application Program Interface (CCAPI) but the work is now maintained under IEC as

standards IEC 61970 and IEC 61968. In contrast to IEC 61850, these standards do not specify communication protocols, but are focused on the object-oriented information modeling in the Common Information Model (CIM). It appears that the information modeling approaches in CIM and IEC 61850 are overlapping, and efforts are made to harmonize these in IEC.

TABLE IV  
OVERVIEW OF SELECTED INFORMATION AND COMMUNICATION STANDARDS

Number	Title	Description
IEC 61850	Communication networks and systems for power utility automation	Information models for substation automation and a single mapping to MMS
IEC 61850-7-420	Communications systems for distributed energy resources (DER) - Logical nodes	Expansion of the information model in 61850
IEC 61850-7-410	Hydroelectric power plants - Communication for monitoring and control	Expansion of the information model in 61850
IEC 61400-25	Communications for monitoring and control of wind power plants	Expansion of the information model in 61850 and additional mappings to e.g. web services and OPC
IEC 61970	Energy management system application program interface (EMS-API)	Control center view of power systems. XML information modeling in CIM, the Common Information Model
IEC 61968	Application integration at electric utilities - System interfaces for distribution management	Extensions of CIM aimed at the distribution level

# 3

## RESULTS

---

In this chapter the main results of the project are summarized. The main results have been published in separate papers, that are included in appendices to this report. Consequently, this chapter is mainly a short summary of the findings, and the reader is encouraged to read the details in the respective papers.

### ***3.1 Reactive Power and Voltage Control in Distribution Grids***

This case study investigates the use of district heating CHP plants for reactive power control. The case has been tested in connection with a CHP plant (cf. section 1.4), with two main purposes: To test the concept of reactive power control on CHP plants, and at the same time test the implementation of IEC 61850-7-420. In addition, a more general study of the applicability of IEC 61850-7-420 for ancillary services control was conducted within this PhD project. The result was recommendations for changes to the standard, that were subsequently incorporated in the standard.

For reactive power, the physical location of the source or sink is of great importance since reactive power transfer is generally undesired due to the resulting voltage drops. This makes distributed resources very well suited for local reactive power balancing within distribution grids.

In the following, a generic control concept for reactive power and voltage control is derived. A simplified control concept is used for simulations and field tests, which is found in paper A. An overview of IEC 61850-7-420, and the experience with the implementation of it, is given in paper B.

#### **3.1.1 Optimization and Control**

The system considered is a single distribution grid, defined as the grid below a single 150/60 kV substation. There are no direct connections with other distribution grids, i.e. the only external connection of the grid considered is the 150/60 kV substation. A conceptual overview of the system is shown in Fig. 5.

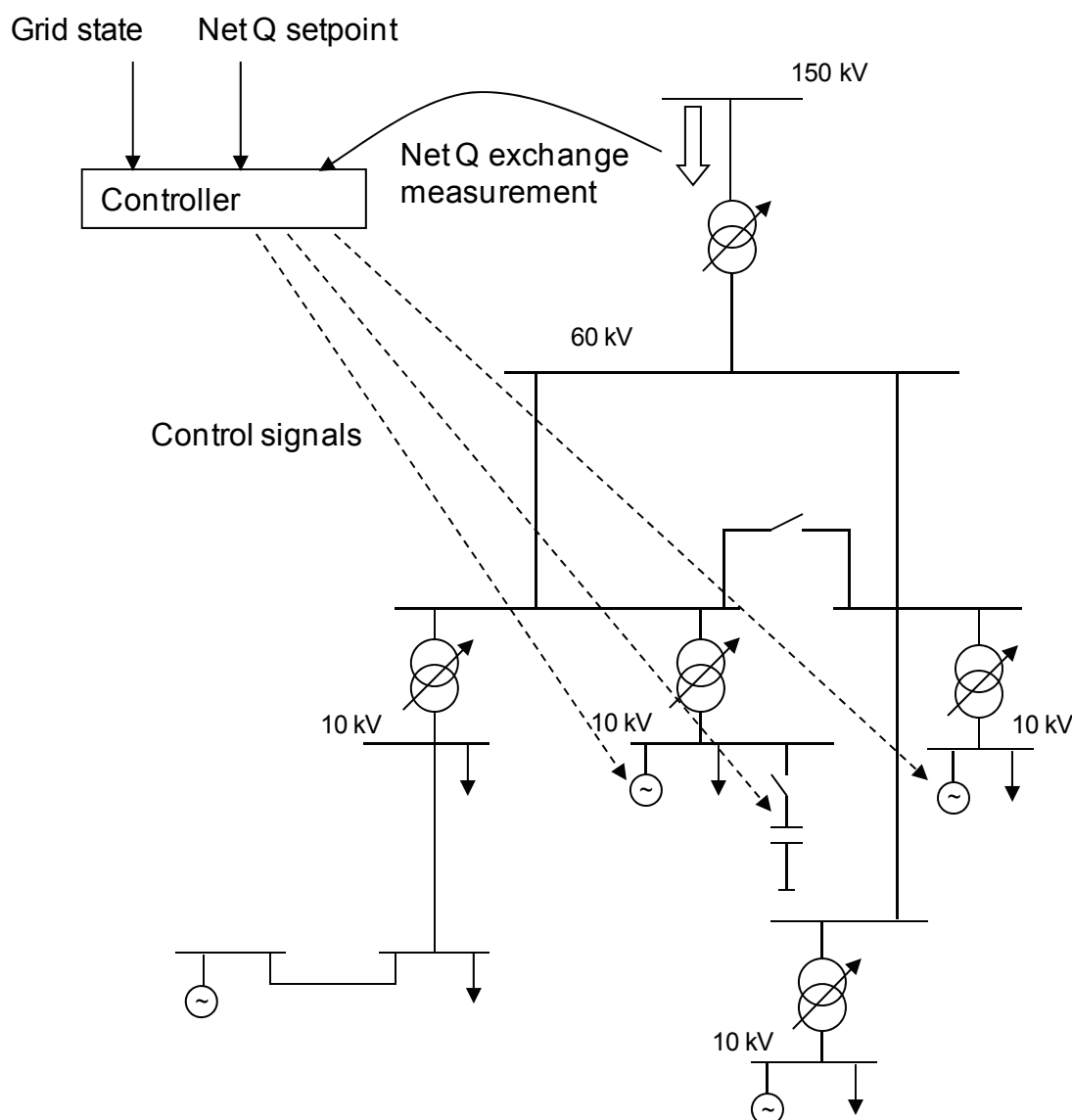

Fig. 5. Principal overview of reactive power control in distribution grids. The controller monitors the distribution grid voltages and net reactive power exchange with the transmission system, and dispatches available reactive power resources, e.g. CHP plants and switched capacitors.

The concept has two overall purposes. One is to assure an optimal distribution of reactive power production and consumption within the distribution grid itself, and another is to assure that the total reactive power consumption or production in the distribution system is within the limits requested by the TSO. This is at present a static limit with a margin, but this control concept in fact provides a VPP-like aggregation that makes it possible for the TSO to dynamically request reactive power injection or absorption in the connection-point between the distribution system and the transmission system. This way, the distribution system can constitute a reactive power resource in the transmission system, and thereby contribute to reactive power flow and voltage control in the transmission system.

In the following these overall objectives are expressed mathematically. The optimization criteria is cost. Besides minimizing the costs of reactive power, the cost of active power losses caused by the reactive power flows must also be minimized. It is apparent that this optimization depends on the active power price, i.e. the total cost function that should be minimized may be written as:

$$C_{Total} = \sum_{i=1}^{N_{Dev}} C_{Dev,i}(p_{real}, P_i, Q_i) + \sum_{i=1}^{N_{Line}} C_{Line,i}(p_{real}, P, Q) \quad (1)$$

where

$C_{Total}$  is the total cost function,

$N_{Dev}$  is the total number of reactive power service devices,

$C_{Dev}$  is an array of costs of reactive power service for each device,

$p_{real}$  is the price of active power,

$P$  and  $Q$  are arrays of active and reactive power production from each device,

$C_{Line}$  is an array of costs of active power losses in each line in the grid, and

$N_{Line}$  is the total number of lines in the grid.

This cost function can be used to optimize the internal distribution of resources. It is assumed that all relevant information about line flows and voltages is available, and that the active power dispatch is given, and not part of the optimization.

The external obligation to the transmission system is formulated as a constraint:

$$|Q_{Err}| = |Q_{Net} - Q_{Set}| \leq Q_{Err,max} \quad (2)$$

Furthermore, a number of additional constraints must be observed:

1. The voltage level at any node in the distribution grid must be kept within given (static) constraints (typically within 5% of nominal voltage)
2. The current in any line may not exceed limits given by the thermal conditions of the line. Temporary overloading may occur.
3. The devices have upper as well as lower reactive power limits that must be observed.

The constraints may be formulated as:

$$\forall i \in [1, N_{Node}]: V_{i,min} \leq V_i \leq V_{i,max} \quad (3)$$

$$\forall i \in [1, N_{Line}]: I_i \leq I_{i,max} \quad (4)$$

$$\forall i \in [1, N_{Dev}]: Q_{i,min} \leq Q_i \leq Q_{i,max} \quad (5)$$

This optimization problem described is essentially an optimal power flow (OPF) problem, and it could be solved with available OPF tools that include reactive power cost functions and dispatch, e.g. MATPOWER [25], [26]. However, it requires that the cost of reactive power for each device is known, which requires extensive knowledge about each device to assess the cost. From that perspective, a market-based solution

would be more feasible, as such a solution ideally has the ability to discover the cost of the service. The extension of this concept to a market-based solution is discussed in section 4.2.

### 3.2 LFC (Regulation) Provided by Coordinated Control of Multiple Distributed Resources

This case study considers the use of aggregation to provide LFC (regulation). The work was performed in connection with the Wide Area Energy Storage and Management System (WAEMS) project at PNNL (cf. section 1.4). The reasoning behind the concept is to aggregate several generation and storage resources that can be geographically wide spread, into a logical unit that acts as a single provider of LFC to the system operator. If the devices are in different control areas, so-called dynamic schedules are sent to the control rooms to adjust the scheduled tie line exchange accordingly. This way the WAEMS provides a virtual merger of control areas, that reduces the overall demand for LFC resources. Additionally, the WAEMS provides the opportunity for internal (to the WAEMS) optimization and distribution of the regulation task.

A specific case study was conducted for a simplified case where the WAEMS consists of only two units, a hydro power plant, and a fast-responding storage device, in this case a flywheel storage device, with the purpose to reduce the wear and tear of the hydro plant due to frequent control actions, and to the largest possible extent avoid operating it outside its optimal range. A system overview is shown in Fig. 6.

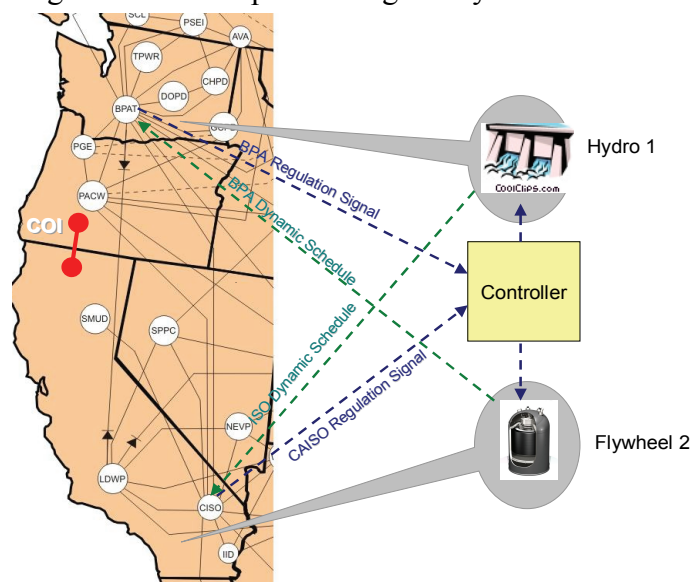

Fig. 6. Overview of the simplified WAEMS.

---

Details about the WAEMS in general can be found in [H]. A review of storage technologies, and the reasons for selecting flywheel storage, are published in [I].

The author's main contribution to the project was the development of a control algorithm for the optimization of the coordinated operation of the hydro power plant and the flywheel storage, and the modeling and simulation of it in the aggregate system. The algorithm uses quadratic programming to find the optimal distribution of the regulation service on the two participating devices. The optimization objective is to distribute the task while observing the state-of-charge of the flywheel storage, and at the same time assure that the requested regulation service is provided by the WAEMS to the system. The results of this work were published in paper C, in which more details about the algorithm, the modeling, and the obtained simulation results are found.

### **3.3 Control-by-Price**

As mentioned in sections 2.2 and 2.3.3, the regulating power market is used to control the active power balance on a time scale from 15 minutes up to several hours. However there are some obstacles that prevent small resources from actively taking part in the RP market. First, the bids must be at least 10 MW – this could be solved by aggregation – but next, the TSO requires online measurements of the active power consumption or production for each device, which would be very costly to implement. Finally, the market is closed for bids 45 minutes before the beginning of the hour for which the bid is given, which means that predictability is required for up to 1 hour and 45 minutes, which is also difficult to promise for many small-scale distributed generation devices, and maybe even more difficult for demand.

In this section an alternative to the RP market is investigated. It is based on one of the ideas in the "homeostatic utility control", envisioned by F.C. Schweppe et al. [4]. In this system, an electricity price is determined every 5 minutes based on the actual condition of the power system, and transmitted to the customers, which can either be net consumers or net producers. Based on the price, a computer (or human) at the customer's site then determines what actions to take, such as reducing or increasing load and/or generation if possible.

The reasoning behind this is that the price at any time can be set so that it expresses the balance between production and consumption. If this price is visible to all producers and consumers, they can adapt their behavior so that their marginal cost or utility, respectively, matches the price. This way, the global optimization performed by the markets is extended towards real-time operation. An illustration of the scope in that connection is shown in Fig. 7.



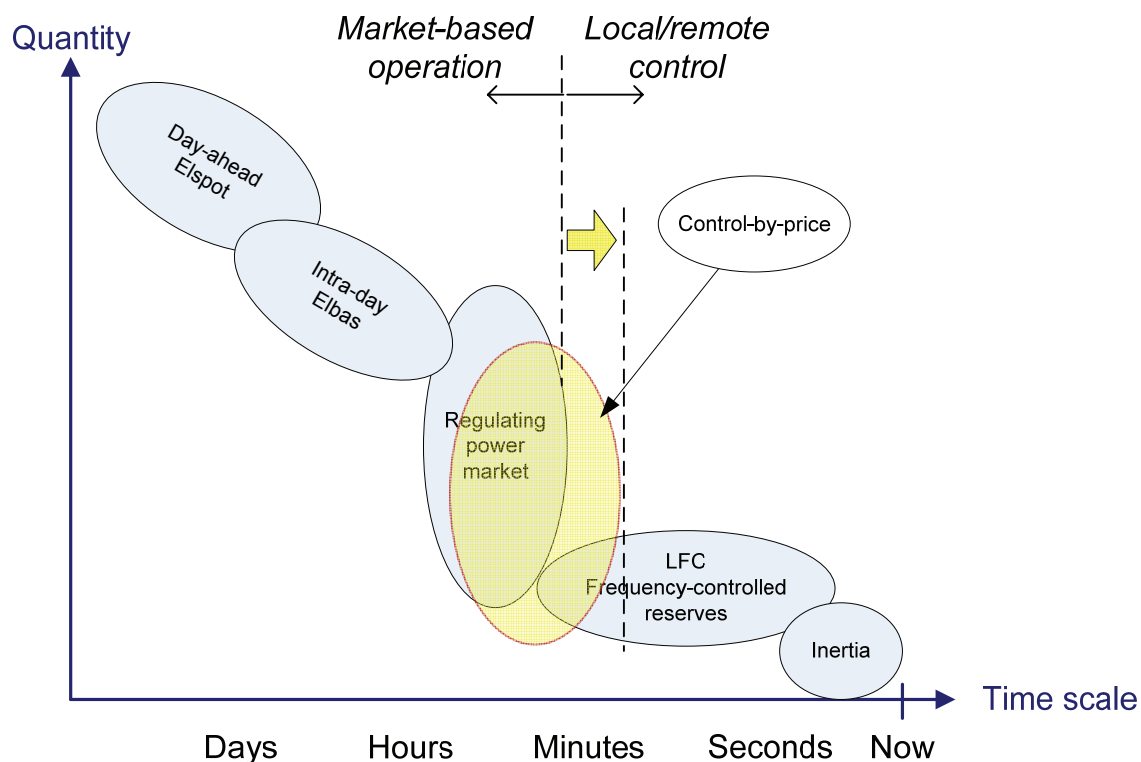

Fig. 7. Scope of the control-by-price concept in relation to existing market-based operations, and local and remote control concepts. The control-by-price concept extends the time scale for market-based operation towards real-time.

Because no bids are given prior to the determination of the price, the price sent to the market players is comparable to a control signal, except that the receiver has no explicit or implicit obligation to follow it. Hence the name "control-by-price" has been used to label this concept in [27] and [28], which is adopted in this report.

The concept has been investigated by means of a design case, laboratory experiments, physical modeling, and simulations. In paper D, an information and communication infrastructure is outlined that illustrates a possible realization of the concept. Furthermore, client-side control algorithms are developed for two applications, a micro-CHP unit, and electric space heating. The infrastructure and the client-side control algorithms have been tested in the laboratory with the two mentioned applications, and the impact on the operation assessed.

This mainly treats the situation seen from the client's side. To assess the impact on the power system, modeling and simulation of the aggregate response is performed in paper F, and an algorithm for setting the price based on the system's power balance is developed. The price determination is considered as part of a closed-loop control system, and the algorithm used is a conventional PID controller. The price response is simulated using the control algorithms and applications from paper D.

### 3.4 Demand as Frequency-controlled Reserve

In this section it is investigated how short-term deferrable demand can supply frequency-controlled reserves. The concept was proposed as part of the "homeostatic utility control", by F.C. Schweppe et al. [4]. The overall idea is to utilize the heat capacity that is inherently present in heating and cooling applications as short-term energy storage. This is obtained by offsetting the temperature setpoint, depending on the locally measured grid frequency, as illustrated in Fig. 8.

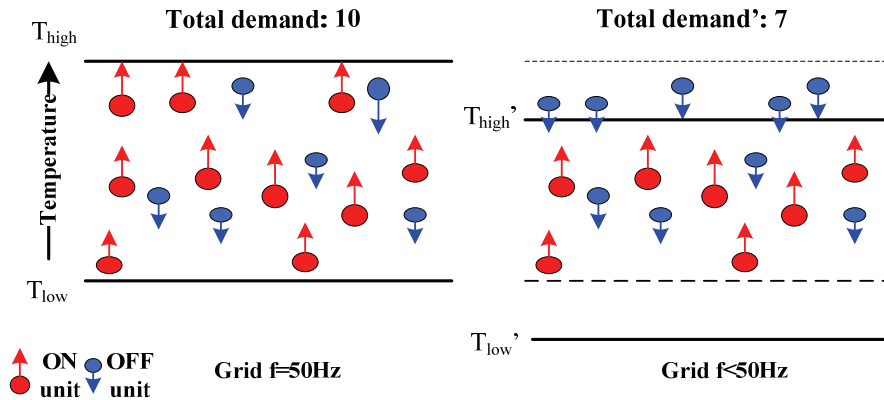

Fig. 8. Illustration of the DFR concept with thermostats in a heating application. When the setpoint is moved as a response to a frequency drop, a proportional fraction of the devices switch off [29], [30].

The work has been focused on laboratory testing with selected applications, and subsequent modeling and simulations. In paper E, a DFR controller is designed and implemented, based on the specifications of frequency-controlled reserves as described in section 2.3.1. Separate designs are sketched for two applications, one is electric space heating, and another is refrigerators. The implementation is tested in the laboratory with a refrigerator, and data analysis performed on the results.

Based on the experience gained with the refrigerator, a detailed thermodynamic model of the refrigerator was developed. The model parameters are determined by inspection of test results. The model is included in the simulations in paper F, where the aggregate behavior of a large number of refrigerators is investigated. Furthermore the interaction with the control-by-price concept is examined (cf. section 3.3).



# 4

## DISCUSSION AND CONCLUSION

---

Most power systems are today deregulated, at least to a certain extent. This means that power production and consumption generally takes place on market conditions, and that system operation and requirements should neither favor nor penalize one market participant over another. When it comes to ancillary services, this also introduces the need for a fair remuneration of providers of these vital services. In this connection, market-based solutions have the built-in advantage that they – at least in theory – have the ability to reveal the true costs of a service, and achieve a globally optimal solution.

Consequently this chapter is much focused on the market-based solutions. First, the control-by-price concept is revisited, and potential challenges and implementation strategies are treated. Next, the possibility of introducing market-based solutions in connection with other ancillary services is considered, and finally, the need for further communication development and standardization for improved integration is discussed.

### **4.1 Control-by-price Challenges**

#### **4.1.1 Non-convex Costs**

The overall assumption for control-by-price to work is that there exists an equilibrium price that will clear the market and establish the balance between supply and demand. If the supply and demand curves are monotonously increasing or decreasing, respectively, this is a valid assumption.

However, the presence of units with cost functions that are not strictly convex, e.g. linear costs, may result in an aggregate supply curve that looks like the one shown as a solid line in Fig. 9. In this case, the desired production is  $Q_B$ , and to obtain that, the price would have to be  $P_A$ . However, setting the price to  $P_A$  or anything higher will result in a total production of at least  $Q_C$ , which is more than what was wanted, and reducing the price to anything lower than  $P_A$  will reduce the production to at most  $Q_A$ , which is less than wanted.



Fig. 9. Supply curve with steps (solid), and a continuous supply curve (dashed)

In a traditional auction-based market, like Elspot or the regulating power market where the price is determined by submitted bids, this problem can be overcome by only accepting the bids needed, in this case corresponding to  $Q_B$ . This of course requires that there are in fact several bids in the range from  $Q_A$  to  $Q_C$  and/or that the bids in question can be curtailed.

This is clearly a caveat of the control-by-price concept. However, in real-life applications it must be considered if this is an academic rather than a real problem. The purpose of introducing a bid-less real-time market is to provide a market for mainly small players (the established markets for larger players already work well). It is therefore reasonable to believe that this concept will attract a very broad range of different kinds of devices, each with their own characteristics and costs. This alone will smoothen the supply curve, and in addition, each unit will be individually constrained by e.g. temperature for heating and cooling applications, or state of charge for electric vehicles. These constraints are dynamically depending on the state of each unit, and the impact of the surroundings on that particular unit. This will further statistically spread out the tendency to respond to a certain price variation, and consequently the aggregate response will be significantly more continuous than depicted by the solid line in Fig. 9, and more likely resemble the dashed line in the same figure, in which there is a one-to-one connection between price and quantity.

#### 4.1.2 Price Discovery

Assuming that a market clearing price exists, as discussed above, the challenge of finding this price still remains. If bids were submitted prior to the market clearing, the clearing price would ideally be found by the intersection of supply and demand curves. However, in the control-by-price concept there are no bids, and consequently the market operator needs to go through a "trial-and-error" process to find the right price. Whenever a price has been set and sent to the market participants, the impact on the power system can be measured by the system frequency and net tie line exchange,

where applicable. This expresses the overall mismatch between production and consumption and can be used in the next iteration to adjust the price in the right direction. In fact, this setup constitutes a closed-loop control system, as outlined in paper F.

In paper F, a conventional PID controller is used to set the price. No explicit knowledge is assumed about the participating units, their state, and/or their response, however, the controller parameters have been tuned to match the entire system as part of the development process. Consequently, if something changes in the system, the controller parameters will most likely need to be re-tuned. This for example means that the parameters would need to be re-tuned when there is a significant change in the outdoor temperature, as this influences the price response by the space heating applications.

This is an undesired behavior in the system, and clearly not very robust. Other controller implementations would better be able to predict the response and thereby increase the robustness and dynamic performance of the price calculation. Ideally, the controller would utilize historical data to correlate price and response, and learn how the response is affected by parameters like outdoor temperature, time-of-day, time-of-year, and other parameters that can influence the price response. This knowledge can then be used to continuously update the models used for prediction, so that the price controller adapts itself to the system as the system develops. This is an interesting area of future research in the control-by-price concept.

Alternatively, an auction-based market could be used to discover the price. An example is demonstrated in [5], in which a local 5-minute market comprising loads as well as small generators was used to manage feeder congestion. In that project, the market price is determined after all consumers as well as producers have placed their bids for the following 5-minute period. The price is calculated as a uniform marginal price, which is then published, and constitutes the real-time price for the next 5 minutes.

The bidding process in this project serves the purpose of discovering the instantaneous supply and demand curves, so that an equilibrium price can be determined. It works well in the project because the clients that submitted the bids were fully automatic, and designed as part of the experiment, and therefore always bid truthfully, and equally important, assured that the market's acceptance or rejection of its bids was respected. In a broader application of this market design, where the bidding process is completely open for the market participants, there would have to be a subsequent settlement that penalizes those that did not comply with their bids, to ensure truthful bidding.

This need for an additional, typically ex post, price adjustment is inherently present in any auction-based forward market, be it on day-ahead or 5-minutes time scale. The problem with the bidding process is that its outcome, namely the supply and demand curves, has little value – if any – if the bids are not truthful. In other words, no bids may

be more useful than wrong bids. Furthermore, the bidding process, market clearing, and subsequent final settlement complicates the system and makes it less attractive for small market players. In contrast, the bid-less control-by-price market design is particularly suitable for small market players, due to its extreme transparency and simplicity. For these players there are two very clear advantages over auction-based markets: First they do not need to be concerned about bidding, and particularly truthful bidding, and second, they always know the prevailing price of electricity and can act accordingly without having to consider subsequent penalties. Even if these processes are fully automatic, the design of client-side systems that can actually do it are likewise more complicated in the auction-based market, mainly due to the problem with complying with the made bids, and the assessment of the risk connected with not doing it.

### **4.1.3 Integration with the Present Real-time Market**

One of the key issues is how the control-by-price concept will operate relative to the present RP market and real-time pricing. The RP market is generally considered quite well-working for the market segment it covers, and it therefore seems feasible to maintain it with the least possible modification. Furthermore, large units with fast ramping rates, e.g. hydro power units, work well in the regulating power market and would introduce problems in a bid-less market design related to the steps in the supply curve as discussed in section 4.1.1. The positive properties of the RP market are closely linked with the two-price settlement system, and consequently it is necessary to maintain this system for large players.

A solution would be to introduce the control-by-price settlement in parallel with the existing real-time pricing, but only allow units below a certain size in the control-by-price settlement. This could be e.g. 10 MW which is the current minimum for participation in the RP market. In such a hybrid real-time pricing system, it is important that the prices are aligned in the two systems. First, this is necessary to obtain an economically efficient dispatch, and second it is necessary that potential control-by-price participants can see that the prices are fair, which is more likely to be the case if they are aligned with the RP market.

Therefore the RP market and the control-by-price system need to be operated as a whole, as illustrated in Fig. 10. It means that the controller that calculates the price needs to consider the availability of RP bids and activate them accordingly as the price is updated. This further underlines the need for more advanced controllers, and e.g. a model-predictive controller could simply include the RP bids in the prediction of supply and demand curves. Alternatively, the predicted supply and demand curves could be conceived as bids in the RP market, but the result would be the same, and the important thing is that the two systems operate as a union.

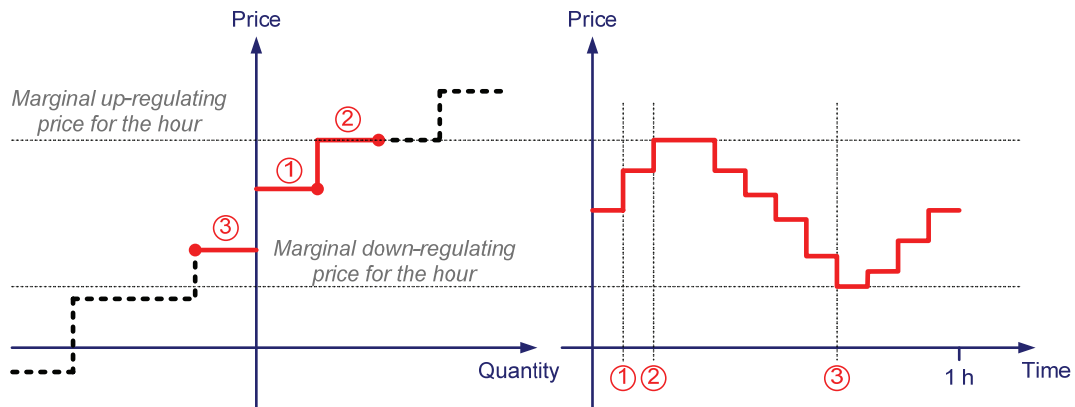

Fig. 10. Illustration of relationship between the acceptance of bids in the regulating power market (left) and the control-by-price published price (right). The two markets are operated as a whole, as if the supply and demand curves of the control-by-price participants were expressed as bids in the regulating power market.

A consequence of this implementation strategy is that large renewable energy facilities, e.g. wind power plants, would still be settled with the two-price system. This implies a penalty for the reduced predictability that these intermittent generation facilities exhibit. However, even if the introduction of the control-by-price concept is not directly removing this penalty, the expected magnitude is reduced due to the increased availability of flexible resources that are made accessible through the concept. In other words, as the control-by-price concept reduces the needs for conventional regulating power, the occurrence of extreme prices in the regulating power market is also likely to be decreased, which in turn reduces the imbalance penalties. Another way of expressing this, is that the volatility of the real-time prices is reduced due to the increased availability of buyers and sellers.

## 4.2 Market-based Reactive Power Control

Considering the reactive power control optimization described in section 3.1, there is a problem with performing the optimal dispatch due to unknown costs of the participating devices. This section discusses the possibility to introduce a market-based approach with the purpose to reveal the cost for each device associated with reactive power control.

Due to the importance of location of reactive power injection or absorption, the most obvious market design appears to be the locational marginal pricing, LMP. In this, the generators submit their bids to the market, and based on the OPF outcome, the marginal price at each bus is paid to all generators at that bus. Consequently, the generators can be paid more than their bid, and assuming that no single generator is able to affect the outcome of the market, this pricing method provides the incentive for the generator to bid their true cost functions into the market. This in turn provides the right input to the OPF algorithm, and the dispatch can then be made on the basis of the optimal prices.



Despite the apparently appealing features of the LMP scheme, there are some drawbacks as well, that make the choice less obvious. Most important is probably the fundamental assumption that no single generator can affect the outcome of the market with its bid. In the case of reactive power, the location of each generator is very important due to losses and voltage drops that occur with reactive power transfer. It means that generators in attractive locations may benefit from submitting bids that are higher than their costs as they are in fact setting the price. The problem with market power in reactive power markets is observed in e.g. [31] where a case study is performed on the Nordic power system. It is observed that several generators possess considerable market power and can set the price. The problem is further analyzed in [32] in several case studies, where the market power is assessed using must-run indices that express the necessity of reactive power from each generator, and thereby its ability to exercise market power. These results support the assumption about market power presence in reactive power markets.

However, the above studies are performed on transmission system cases, which implies long distance power lines. Whether or not the market power problem is equally predominant in distribution systems would be an interesting topic for future research in this field. On the other hand, even if market power was not a problem, and the units would bid their true marginal costs, these costs would be very low. Since reactive power does not carry energy, there is no natural additional expense for e.g. a CHP unit to provide it, as for active power that requires additional fuel. The losses in the generator are increased with reactive power production or consumption, but compared with the total costs this part of the operation cost is very little. In more general terms, it is a problem with most reactive power resources that the marginal cost of supplying or absorbing reactive power is very little compared with the investment cost. Consequently, a marginal pricing solution would most likely not cover the actual costs.

Finally, with regards to implementing the market, and in particular the OPF solver, there is a problem with devices that cannot adjust their production or consumption of reactive power gradually like a synchronous generator, but only in steps, or even just on or off. This applies for example to switched capacitor banks. Such devices are not handled very well by the usual OPF algorithms, but other solutions like combinatorial or evolutionary algorithms may be usable [33].

To conclude, it appears that the remote control concept described in section 3.1 is a reasonable way to control reactive power flows in the distribution grids, and that introducing a market for reactive power does not appear to be feasible, due to the above reasons. However, an alternative solution is to simply neglect the costs of the reactive power itself, and instead introduce a payment for reactive power capacity and controllability. This is in line with the observations in [34], in which reactive power metering is also pointed out as a potential barrier for an efficient implementation of a reactive power market.

If such a payment scheme is introduced on the transmission level, a tender market could be established for reactive power contracts. The aggregation solution proposed in section 3.1 would be able to participate in this setup, given that it is able to receive a reactive power dispatch signal from the TSO, and thereby act as a reactive power source or sink in a single connection point on the transmission system. This development towards focusing on the reactive power *service*, rather than on reactive power itself, appears to be a reasonable track towards competition and cost reduction in this area.

### **4.3 Other Ancillary Services Remuneration**

With regards to the LFC and frequency-controlled reserves described in sections 3.2 and 3.4 respectively, the payment for these services is also normally based on payment for the availability of the service, rather than the energy provided or absorbed by the service.

Starting with the LFC, the use of aggregation through the WAEMS makes it possible for the participating units to sell the LFC service in the existing market for this, called regulation in the American context. Alternatively, it would in theory be possible to use market-based control like the control-by-price concept for this service, but the requirement of a 4 seconds update interval makes the communication of the price, the metering, and the final settlement prohibitively complicated.

In the Danish context this would be more feasible since the required response time is 15 minutes [24], which means that the control-by-price concept with 5 minutes update interval as depicted in section 3.3, would in fact be able to replace the LFC service fully or partly. The requirements described in section 2.3.2 regarding overall LFC controller performance with regards to restoration time and overshoot are not met by the simulations in paper F, but as previously discussed (cf. section 4.1.2) the dynamic performance of the closed-loop control could most likely be improved, and might then be able to meet UCTE's requirements. Furthermore, the present UCTE requirements are based on a control scheme, where the next link in the chain is manual control actions with 15 minutes response time. With the introduction of 5-minute real-time pricing through the control-by-price concept, it may turn out that the LFC system is superfluous.

Finally, with regards to the DFR concept described in section 3.4, a direct market-based solution is not feasible. The concept is based on extremely simple electronics and no communication equipment, so the possibility for a DFR device to actively participate in a market is not present. In fact, this concept is based on a fit-and-forget strategy, in which the end-user should not have any way of enabling or disabling the function. Consequently remuneration should take place at the time of purchase. The TSO should provide a financial incentive to choose e.g. refrigerators with built-in DFR technology, similar to the incentive schemes used to promote energy efficient appliances. Analyses in [35] indicate that if the TSO would pay a similar amount per MWh frequency-

controlled reserves as it is presently paying for the conventional reserves, the production costs of the DFR technology could be covered. This would lead to a gradual increase of DFR propagation, and hence reduce the need for conventional reserves.

#### **4.4 "The Super-Market"**

Previously, selected ancillary services have been considered in relation to selected technologies. However, some technologies have the ability to provide a range of different ancillary services, but not necessarily at the same time. This is for example the case for the district heating CHP plants, that can choose to sell its electricity in the day-ahead market, or wait and try to sell it in the RP market. Furthermore, if – and only if – it is online it may be able to participate in the daily auctions for frequency-controlled reserves, and finally if a reactive power payment scheme was established this would also be an option. All these options complicate the optimization seen from the point of view of the plant operator, as some options are mutually exclusive whereas others are depending on each other. Likewise, from the point of view of the system operator, the demand for different ancillary services may depend on others, e.g. the reactive power dispatch that depends on the active power flows as well.

This leads to the idea about a market that integrates all these options in a single marketplace for electric energy and ancillary services for distributed energy resources. This market above markets, or super-market, would ideally be able to coordinate all the available resources, and find the optimal dispatch that best utilizes each unit's capabilities, at the least possible cost.

A number of questions emerge with this idea. First of all, the question about bid structure. Clearly the bids are complex, and must reflect the characteristics and capabilities of each device in question, as well as its location for optimal dispatch. Next is the problem with the optimization algorithm. Conventional algorithms like OPF solvers would not be able to handle the combinatorial nature of the problem. More suitable are probably e.g. genetic algorithms, which have been successfully applied to the reactive power dispatch problem [33], and could be extended to include other services, as well as costs.

Even though these problems could possibly be solved, it is questionable if the solution would be feasible. The underlying problems with e.g. market power in the reactive power dispatch will not disappear by introducing a more complex market, as this is caused by the electrical laws. On the contrary, the opportunity for market power could be further increased by an overly complex market, if the complexity means that potential market players choose not to participate. However, the overall concept of making an all-in-one optimization of all available resources in a distribution grid still seems appealing, and future research in this area is recommended.

---

## **4.5 Aggregation vs. Market-based Control**

The use of an aggregation strategy could provide some of the same features with regards to optimization as described in the previous section, but without the need to express complex technical interdependencies as market bids. The aggregating entities described in sections 3.1 and 3.2 communicate directly with the participating devices and can request any information that might be necessary to perform an optimal distribution of tasks. The aggregator can then participate in the already existing markets, if any, for the relevant ancillary services in line with conventional power plants. Compared with the super-market approach, this appears simpler and more attractive, but on the other hand requires that the devices trust the aggregator, and receive satisfactory remuneration for their services.

The use of aggregation should generally not prevent the implementation of market-based control. Present market designs in some cases make aggregation the only possible way to participate in the market, but looking ahead it is important that market-based solutions with direct DER participation are implemented where possible. In this way, aggregation and market-based solutions can coexist, and some units will choose to participate directly in the market-based control scheme, if possible, whereas others will need or prefer to go through an aggregator to participate in the markets. This way it is up to the aggregation entity to prove its worth in the markets, and convert the benefits of the aggregate optimization to additional profits for its participating devices.

An advantage of aggregation compared with direct participation in market-based control, is that the aggregation entity can perform internal optimization that is not easily expressed in bids. In the example in section 3.2, one of the purposes is to reduce the tear and wear on one of the participating units by letting another unit handle the smaller and more frequent control actions. This objective is not easily expressed in a market bid.

On the other hand, this also implies that a lot of information is gathered in a single location to perform the optimization. Consequently, information must be transferred from each device, which requires communication equipment, protocols, and information models for each device, and additionally, the information must be stored and processed by the aggregation entity. The complexity of this, compared with the simpler market-based control, where applicable, must be compared with the benefits. However, in some cases the market-based approach is not a feasible solution, (cf. sections 4.2 and 4.3), which means that aggregation may be the only way to utilize DER for these services.

## **4.6 Communication**

For aggregation implementation and roll-out to become efficient, it is preferable that communication protocols and information models are standardized. The international standard IEC 61850, and in particular its extension IEC 61850-7-420 for DER, is a useful step in that direction. Its SCADA-oriented architecture provides an efficient

interface for the aggregation entity to retrieve all relevant information from the devices. This however requires that the device controller exposes the relevant logical nodes, which is at present beyond the standard's requirements. This problem is discussed in more detail in paper B.

Another problem with this standard is that it is limited to the use of the MMS protocol as its under-lying data protocol. This in reality means that implementations are depending on third-part software, or the development of an MMS stack in connection with the application development. For smaller manufacturers this could imply a comparably large expense in the development phase, and result in lacking support for the standard. However, alternatives to MMS seem to be on the way, and future implementations may be able to use more accessible protocols e.g. HTTP as illustrated in [36].

### **4.7 Conclusion**

In this project a number of integration and control strategies for the exploitation of ancillary services from DER have been investigated. The results show that different types of DER can provide a significant contribution to system operation.

The use of local, remote, and market-based control is considered. The applicability of these have been demonstrated by laboratory and field tests, case studies, modeling, and simulations. Particularly the use of demand as frequency-controlled reserve, and price-responsive DER, seem to be promising technologies in future power system balancing. For the price-responsive DER to become a success, more research is needed in control algorithms, both in the system-level price calculation, and in the individual DER's decision-making. Both need improvements, to obtain satisfactory dynamic performance and robustness of the aggregate system, and particularly the use of prediction models is a relevant topic to consider.

More advanced features can be utilized by aggregation, however, the complexity implied by this may compromise the overall feasibility. A unified, market-based optimization of all available DER in a distribution grid context is another interesting topic for future research, that must overcome problems with market power, complexity as a market barrier, and general practicability of the concept.

Finally, with regards to future research, it should be mentioned that even though several market-based solutions have been considered in this project, and the overall rationale is to provide cost-efficient solutions, no firm quantification of benefits or costs have been performed in the project. In addition to the technical challenges addressed, future analyses should therefore also perform cost-benefit analyses of the different integration concepts. This is particularly relevant for the advanced control concepts, where the immediate benefit may appear less obvious, compared with the complexity that is introduced to realize it.

Eventual realization of DER integration strategies requires active participation from the system operators, in particular the TSOs. The TSOs are natural monopolies that decide which of these integration strategies to follow, and thereby have the key to unlock the vault of opportunities provided by efficient DER integration. In the near future, demonstration projects of relevant technologies, such as DFR, and control-by-price, will hopefully bring confidence in these concepts, and prepare the ground for an actual roll-out. The experience gained, and the technical solutions developed in this PhD project can be utilized in such demonstration projects, and in a longer timescale contribute to forming the basis for further increase in the renewable energy sources penetration in the power system.



## REFERENCES

---

- [1] The Danish Energy Authority, "Energy Statistics 2008", available online at [www.ens.dk](http://www.ens.dk)
- [2] Energinet.dk, "EcoGrid.dk Phase 1, Summary Report, Steps Toward a Danish Power System with 50% Wind Energy", available online at [www.energinet.dk](http://www.energinet.dk)
- [3] F. C. Schweppe, "Power Systems 2000: Hierarchical Control Strategies", *IEEE Spectrum*, July 1978.
- [4] F.C. Schweppe et.al., "Homeostatic Utility Control", *IEEE Transactions on Power Apparatus and Systems*, Vol.PAS-99, No.3, May-June 1980, pp.1151-1163
- [5] D. J. Hammerstrom et al., "Pacific Northwest GridWise™ Testbed Demonstration Projects, Part I. Olympic Peninsula Project", National Technical Information Service, U.S. Department of Commerce, October 2007
- [6] D. J. Hammerstrom et al., "Pacific Northwest GridWise™ Testbed Demonstration Projects, Part II. Grid Friendly™ Appliance Project", National Technical Information Service, U.S. Department of Commerce, 2007.
- [7] "Smart Domestic Appliances Supporting the System Integration of Renewable Energy", project results available online [www.smart-a.org](http://www.smart-a.org)
- [8] "Active Distribution Networks With Full Integration of Demand and Distributed Energy Resources (ADDRESS)", project ongoing, information available at: [www.addressfp7.org](http://www.addressfp7.org)
- [9] IEEE Technical Report 1550, "UCA™ Services, Models and Profiles", November, 1999
- [10] "PUDEL projektet slurapport", (translated: The PUDEL project, summary report), published 2005 by Eltra, available online: [www.energinet.dk](http://www.energinet.dk)
- [11] The Danish Energy Authority, spreadsheet "DC\_KVaerker\_1310\_2005.xls" available online at [www.ens.dk](http://www.ens.dk)
- [12] The Danish Energy Authority, spreadsheet "CentraleVaerker\_2810\_2005.xls" available online at [www.ens.dk](http://www.ens.dk)



## References

---

- [13] The Danish Energy Authority, spreadsheet "Oversigtstabeller\_UK-DK.xls" available online at [www.ens.dk](http://www.ens.dk)
- [14] Energinet.dk, "Technical Regulations for thermal power station units of 1.5 MW or above. Regulation TF 3.2.3", rev. July 2006, available online at [www.energinet.dk](http://www.energinet.dk)
- [15] S.Stoft, "Power System Economics", IEEE Press, 2002
- [16] Nordic Energy Regulators, "Development of a Common Nordic Balance Settlement", NordReg, 2006
- [17] Nordel, "Harmonisation of Balance Regulation in the Nordic Countries", report of December 2008
- [18] Nordel Market Development Group, "Description of Balance Regulation in the Nordic Countries", report of March 2008
- [19] Energinet.dk, market data available online: [www.energinet.dk](http://www.energinet.dk)
- [20] Y. G. Rebours,, D. S. Kirschen, M. Trotignon, S. Rossignol, "A Survey of Frequency and Voltage Control Ancillary Services—Part I: Technical Features", *IEEE Transactions on Power Systems*, Vol. 22, No. 1, February 2007.
- [21] Y. G. Rebours,, D. S. Kirschen, M. Trotignon, S. Rossignol, "A Survey of Frequency and Voltage Control Ancillary Services—Part II: Economic Features", *IEEE Transactions on Power Systems*, Vol. 22, No. 1, February 2007.
- [22] "UCTE Operation Handbook", available online at [www.entsoe.eu](http://www.entsoe.eu)
- [23] "AGREEMENT (Translation) regarding operation of the interconnected Nordic power system (System Operation Agreement)", 2008, available online at [www.entsoe.eu](http://www.entsoe.eu)
- [24] Energinet.dk, "Systemydelse til levering i Danmark – Udbudsbetingelser", Dok. 9855/09 v3, dated 8 July 2009, translated title: "Ancillary services provided in Denmark - Tender Conditions", currently no English translation available
- [25] R. D. Zimmerman, C. E. Murillo-Sánchez, D. Gan, "A MATLAB Power System Simulation Package", Available online: <http://www.pserc.cornell.edu/matpower/>
- [26] R. D. Zimmerman, C. E. Murillo-Sanchez, R. J. Thomas, "MATPOWER's extensible optimal power flow architecture", IEEE Power & Energy Society General Meeting, 2009. PES '09.
- [27] F.L. Alvarado, "Controlling power systems with price signals", *Decision Support Systems* 40 (2005) 495–504
- [28] F.L. Alvarado, "Is system control entirely by price feasible?", Proceedings of 2003 HICSS, Waikoloa, Hawaii, 2003

- 
- [29] Z. Xu,, J. Østergaard, M. Togeby, C. Marcus-Møller, "Design and modelling of thermostatically controlled loads as frequency controlled reserve," IEEE Power Engineering Society General Meeting, 2007.
- [30] J. Short, S. Leach, "Using smart appliances to provide peak-load management and increase the efficiency of the electricity network", International Energy Efficiency in Domestic Appliances and Lighting Conference, 2006.
- [31] J. Zhong, E. Nobile, A. Bose, and K. Bhattacharya, "Localized reactive power markets using the concept of voltage control areas," *IEEE Transactions on Power Systems*, vol. 19, no. 3, Aug. 2004.
- [32] D. Feng, J. Zhong, D. Gan, "Reactive Market Power Analysis Using Must-Run Indices", *IEEE Transactions On Power Systems*, vol. 23, no. 2, May 2008
- [33] H. Kim, J. Kim, C. Yoon, M. Shin, T. Oh, "Optimal Voltage and Reactive Power Control of Local Area Using Genetic Algorithm", book chapter from "Knowledge-Based Intelligent Information and Engineering Systems", Springer, 2006
- [34] R. Hirvonen, R. Beune, L. Mogridge, R. Martinez, K. Roudén, O. Vatshelle, "Is There Market For Reactive Power Services - Possibilities And Problems", CIGRE Session 2000, Paper presented on behalf of Joint Working Group 39/11.
- [35] Z. Xu, M. Togeby, J. Østergaard, "Demand as Frequency Controlled Reserve – Final report of the PSO project", published by Ørsted-DTU, 2008
- [36] A. B. Pedersen, E. B. Hauksson, P. B. Andersen, B. Poulsen, C. Træholt, D. Gantenbein, "Facilitating a generic communication interface to distributed energy resources - Mapping IEC 61850 to RESTful services", First IEEE International Conference on Smart Grid Communications (SmartGridComm), 2010, submitted.



# **A**

## **REACTIVE POWER CONTROL WITH CHP PLANTS - A DEMONSTRATION**

---

This paper has been accepted for publication on the International Council On Large Electric Systems (CIGRE) session 2010.



## **Reactive power control with CHP plants - A demonstration**

**P. NYENG\*, J. ØSTERGAARD**  
Technical University of Denmark  
Denmark

**C.A. ANDERSEN, J. DALL**  
EURISCO  
Denmark

**C. STRUNGE**  
Energinet.dk  
Denmark

### **SUMMARY**

In this project the potential for ancillary services provision by distributed energy resources is investigated. Specifically, the provision of reactive power control by combined heat and power plants is examined, and the application of the new standard for DER communication systems, IEC 61850-7-420, is investigated as a means to improve the control possibilities.

To gain first-hand experience on the topic, a demonstration case has been designed and implemented in the project. The demonstration case is based on the issue of reactive power balancing in distribution grids, an issue that is attracting increasing attention from the distribution grid operators due to three main reasons, that all call for flexible reactive power control resources: First, the presence of DER, like wind turbines and CHP plants, makes the conditions less predictable, second, the intensive transform from overhead lines to underground cables has changed the reactive power balance, and third, the TSO has introduced restrictions in the allowed exchange of reactive power between the transmission system and distribution grids (known as the *Mvar-arrangement*).

The demonstration includes a CHP plant with an electric power rating of 7.3 MW on two synchronous generators. A closed-loop control is implemented, that remote controls the CHP plant to achieve a certain reactive power flow in a near-by substation. The solution communicates with the grid operator's existing SCADA system to obtain measurements from the substation, and subsequently determines and transmits reactive power setpoint values to the generators in the CHP plant. An important part of the implementation is the communication link between the controller and the CHP plant, which is implemented in compliance with IEC 61850-7-420 using an industrial PC platform.

In this paper, the implementation and the experience gained is described in more detail. Due to the comprehensiveness of IEC 61850-7-420, the implementation has been a challenging, but achievable task. The test results of the entire control system look promising, but also reveal some issues related to the quality of measurements, and to the response time of the CHP plant, that need further improvement.

### **KEYWORDS**

Reactive Power – Distributed Generation – Ancillary Services – IEC 61850

## **1. INTRODUCTION**

The propagation of distributed energy resources (mainly wind turbines and local combined heat and power plants) in the Danish power system has increased, from being negligible to generate more than 40% of the annual production of electric energy. In the past, the distributed energy resources had priority over conventional power plants, meaning they could feed electric power into the grid at the time most convenient for the energy resource – but not necessarily for the power system. Lately, many CHP plants have switched to operating on market terms, and sell their energy in the day-ahead electricity market Nordpool or even in the hourly market for stand-by reserves.

But important ancillary services, necessary to secure the system operation, are still supplied mainly by the large conventional power plants, though many distributed energy resources in fact do have the capability to supply at least some of these services. In other words, there is a currently unused potential for DER to supply ancillary services to the system, and thereby increase the flexibility and adaptability of the power system. In the Nextgen project – a collaboration between a university, a TSO, and industrial partners – the question on how to exploit this potential by means of e.g. communication systems and new markets is examined.

The local CHP plants can make a significant contribution to reactive power and voltage control, and thereby support both transmission and distribution system operators in their operations. A typical CHP unit is a gas-fired engine driving a synchronous generator that can vary its reactive power output or absorption. However, to utilize this, the plant must be able to receive commands, and likewise supply information about its operation to the system. In the following it is examined how this can be exploited to assist the distribution grid operator in maintaining his Mvar obligations to the TSO. First, simulations are made where the general applicability of the concept is investigated. In this setup it is expected that a number of CHP plants in a distribution grid contribute to controlling the reactive power exchange between the distribution grid and the transmission system. Secondly, the concept is tested in a smaller section of a network with only one CHP plant involved, and the implementation of IEC 61850-7-420 [1] on a CHP plant is described. Finally, the conclusion summarizes and evaluates the results, the practical experience gained, and suggests further improvements to be made.

## **2. REACTIVE POWER CONTROLLER SIMULATION**

A controller for reactive power control in distribution grids was designed. The concept is based on the requirements from the TSO for the reactive power exchange between the transmission system and the distribution grid. The controller measures this exchange and adjusts reactive power resources in the distribution grid to obtain a setpoint value given by the TSO. An outline of the concept is shown in figure 1.

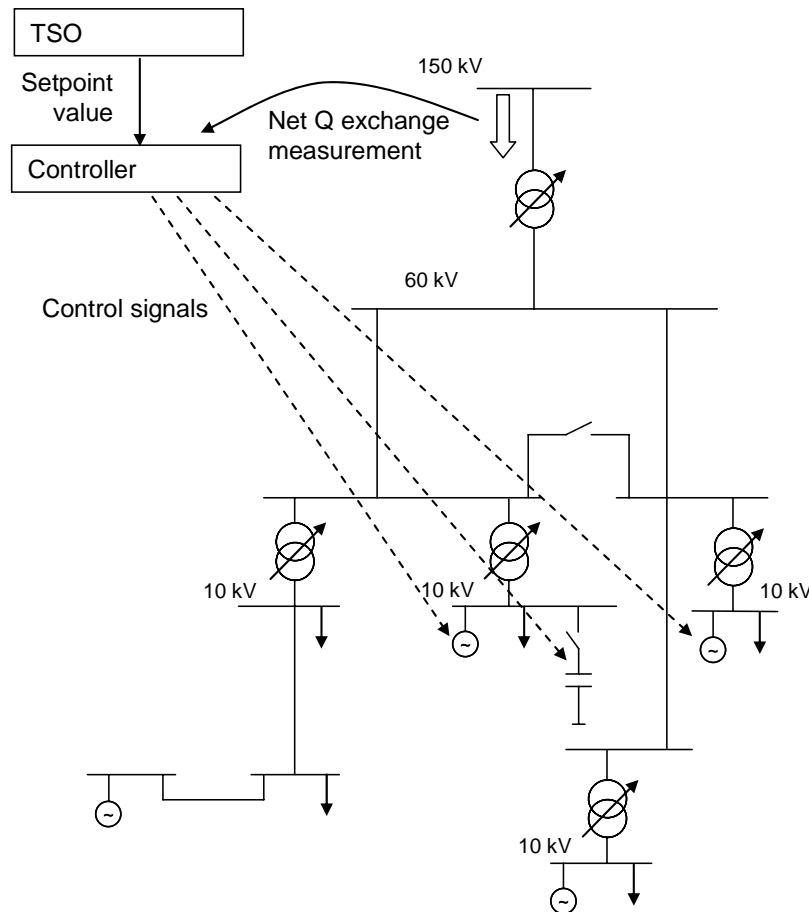

Figure 1. Conceptual illustration of how the controller works in a simplified view of a distribution grid.

The setpoint value would – under the present conditions – be static, and based on the assigned Mvar obligations by the TSO. However, in a future setup the distribution grids would be able to support the transmission system operation by providing dynamic reactive power control services in the interface to the transmission system. Throughout the following simulations and experimental results, a static setpoint value of 0 Mvar has been used, meaning that the distribution grid to the largest possible extent will operate neutrally on the reactive power balance in the transmission system.

The controller can dispatch reactive power resources in order to obtain the desired setpoint value. The resources can include any device that can adjust its reactive power flow, e.g. synchronous generators in CHP plants, wind turbines with reactive power control capability, and switched capacitor banks. In this project the focus is on CHP plants, and consequently only these have been included as controllable devices in the simulations.

To validate the feasibility of the concept, simulations have been made based on a distribution network model that has been derived from data about several Danish distribution grids. The model is therefore no specific grid, but has been designed to resemble a typical Danish distribution grid, and has the following key characteristics:

- 60 kV meshed network, with a roughly even share of cables and overhead lines
- 10 kV feeders, mainly consisting of underground cables
- significant wind power and CHP capacity

The simulations are made on the 60 kV level. The CHP plants to be controlled are expected to be installed on the 10 kV level, but close to the 60 kV substations so that no significant reactive or real power losses are present in the connection between the generator and the grid. The 60 kV network consists of totally 9 busses, out of which only one is connected to the 150 kV transmission system.



The network is structured as two loops, one cable loop that would typically be found in a populated area, and connected to this an overhead line loop supplying the rural areas. An overview of the network is shown in figure 2.

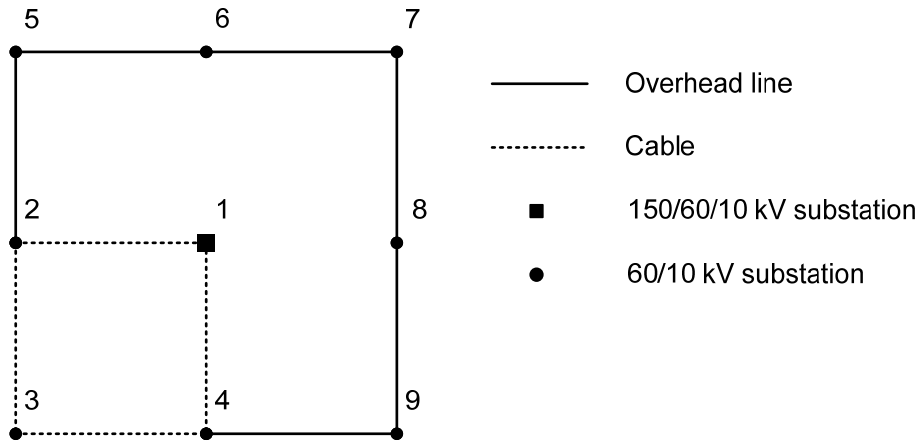

Figure 2. Overview of the generic distribution network model that is used in the simulations. All lines have the same length, in this case 10 km per line.

The key characteristics of the simulation model are summarized in table I. Cable data have been extracted from [2] and compared with information from distribution system operators. The 10 kV cables' capacitance is modelled as a fixed reactive power injection in the 60/10 kV substations. Generation capacity and peak demand in each node have been selected to resemble the characteristics of a Danish distribution grid. The timely variation of demand, CHP generation and wind power generation is based on statistical data from the Danish TSO. However, since these CHP plants will typically operate at full load or not at all, their generation profile has been adapted similarly.

TABLE I

60 kV line length (all lines)	10 km
60 kV cable data	$C = 0.20 \mu\text{F}/\text{km}$ , $L = 0.40 \text{ mH}/\text{km}$ , $R = 0.20 \Omega/\text{km}$
10 kV cable length per substation	100 km
10 kV cable capacitance	$0.40 \mu\text{F}/\text{km}$
Peak demand	10 MW in nodes 1 to 4 , 5 MW in other nodes
CHP capacity	10 MW in node 3 , 5 MW in nodes 5 and 8
Wind power capacity	20 MW in node 7

Based on this model, three different simulation cases are run: One with the controller in action, i.e. with an attempt to obtain no reactive power exchange between transmission and distribution systems, another where the CHP plants are operated with a fixed power factor at 0.95 lagging, and finally a reference case, where the CHP plants are operated with unity power factor, thereby not affecting the reactive power balance of the system. The results are shown in figure 3. It is observed how the control concept maintains the requested setpoint value quite well, when the CHP plants are operating. In the case with fixed power factor, there is a large shift in the reactive power balance when the CHP plants cut in, but the timing is quite good, considering the general trend in reactive power demand.

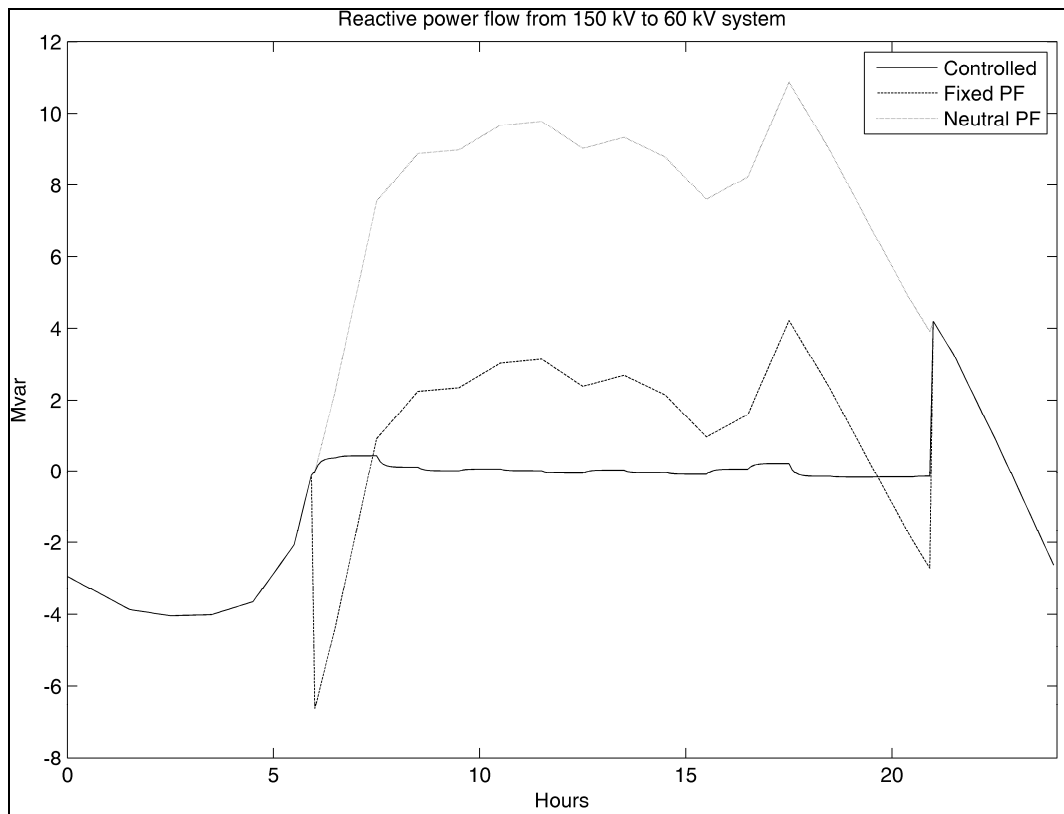

Figure 3. Simulation results, illustrating the reactive power flow in the 150/60 kV substation. The solid line shows the result obtained when the controller is active, the dashed line is the result when the CHP plants use a fixed power factor (0.95 lagging), and the dotted line is the result when the CHP plants neither generate nor absorb reactive power.

### 3. DEMONSTRATION CASE

To demonstrate that the concept is in fact feasible in real life, and to evaluate the application of IEC 61850-7-420 for this purpose a demonstration has been made. The setup is a small-scale demonstration of the overall concept, and is reduced to include the grid supplied through a single 60/10 kV transformer, including a single CHP plant, that comprises two individual generators. An overview is found in figure 4.

A very important point in the control concept is that it utilizes existing assets in the distribution grids that are simply controlled better. Therefore, in the demonstration it has been a target to make as few changes to the existing systems as possible. As an example, this means that the measurement of the reactive power exchange that the controller uses as input, is acquired through the existing SCADA system of the distribution system operator, by a simple file transfer. The CHP plant's existing control system is also maintained, and the standards-compliant interface is made in a separate device – a gateway – that in turn is hard-wired to the CHP plant's own SCADA system.

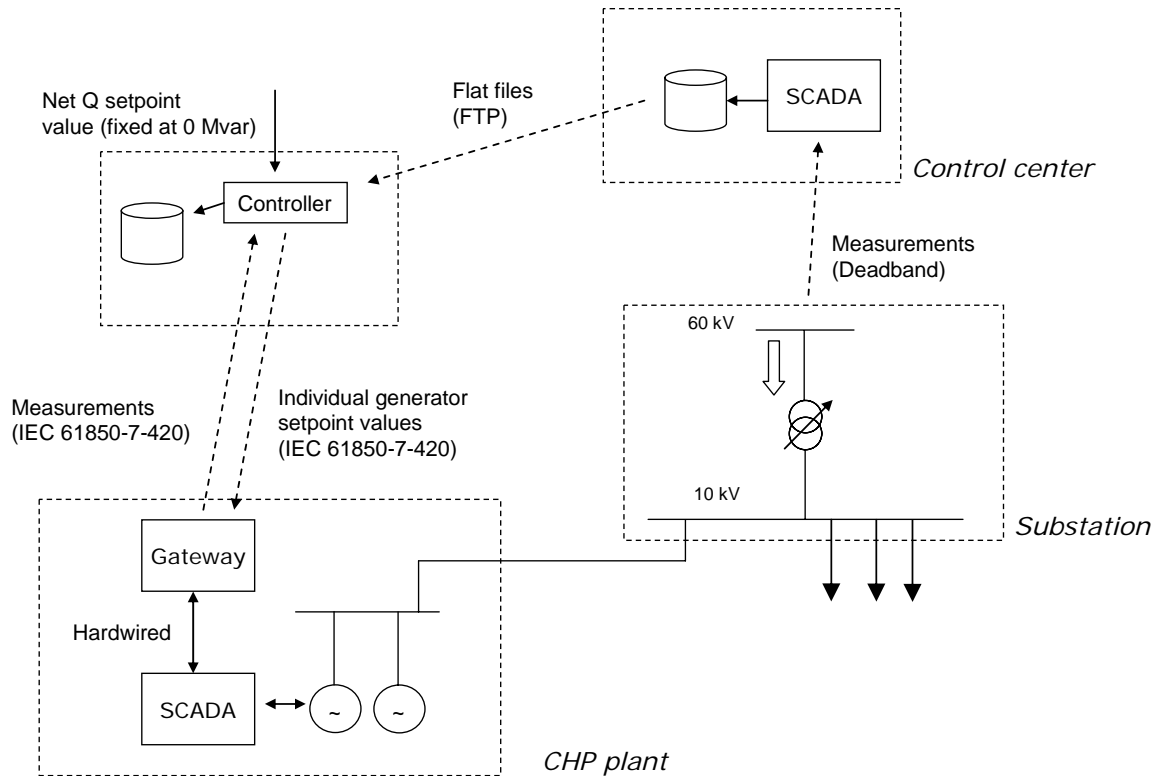

Figure 4. Overview of the demonstration setup, including the information flow.

The controller basically uses a discrete-time, linear, integral control algorithm, and some additional steps to get from input to output values. It only updates its outputs, if the measured input deviates beyond a predefined threshold from the setpoint value. This is to compensate for the deadband included in the measurement of the reactive power flow in the substation. The controller also needs to check which generators are online and ready for reactive power control, before it can calculate the distribution among individual generators. This is achieved by polling the generators for their status prior to updating the output. Once the new output has been calculated, the individual generator setpoint values are set relative to their present real power generation. In other words, the distribution is made so that all generators operate with the same power factor. Finally, the individual setpoint values are communicated to the generators, once every 2 minutes.

#### 4. GATEWAY IMPLEMENTATION

The gateway is implemented on an industrial PC platform. It is hardwired to the plant's SCADA system through analog and digital input and output modules, connected to a Profibus interface on the PC. The software on the gateway implements an IEC 61850-7-420 compliant server, that the controller connects to for information exchange and control. The gateway application acts as a middle-layer between the information structures specified in IEC 61850-7-420, and the physical signals that are hard-wired to the plant's SCADA system. Further details about the implementation are published separately.

The most important parameters that are sent from the plant to the controller are the values of the present real and reactive power generation, and the present status of each generator. These are used to determine the availability for reactive power control, and to distribute the reactive power load on the generators. In addition, the controller application stores the values in a database for subsequent data analysis.

The only commands sent to the plant are those used to control the reactive power generation or absorption. This means that the controller cannot interfere with the normal operation of the plant, and for example force it start or stop unscheduled.

## 5. EXPERIMENTAL RESULTS

A series of tests have been run on the system. An example of what happens, when the controller is activated is seen in figure 5. The controller is activated about 45 minutes into the data set, and it is observed how the reactive power flow in the substation transformer drops from a value around 1.8 Mvar to around 0 Mvar, equal to the external reference value. There is a short transition period, or glitch, immediately after the controller is activated, but this is due to the fact that a connector has to be manually moved, to enable the control signal to reach the generator, which can cause some unintended behaviour. It can also be observed that the real power generation is not affected by the controller.

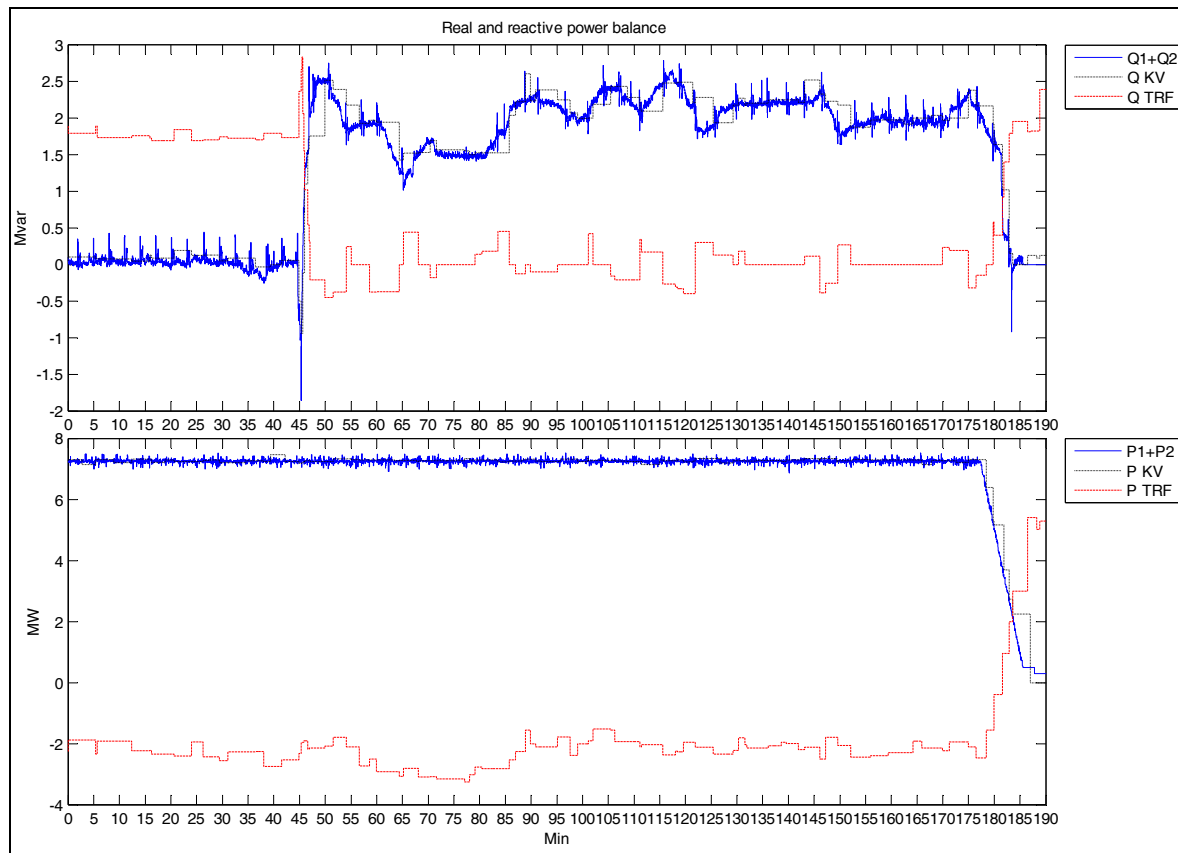

Figure 5. Time series of reactive (top) and real (bottom) power flows. “ $Q1+Q2$ ” and “ $Q KV$ ” are the total reactive power generation by the CHP plant, measured in the plant, and in the substation, respectively. “ $Q TRF$ ” is the reactive power flow in the substation transformer from the HV to LV side. A similar designation applies for the real power flows.

Despite that the result is quite promising it also reveals a problem with oscillation. This is seen in figure 5, most significantly between 85 and 120 minutes into the data set. A detailed analysis of this problem shows that it is caused by the deadband on the transformer reactive power measurement that appears to be much larger than expected. Based on this observation, a new test has been run where the deadband in this measurement is reduced, but unfortunately, in the meanwhile the plant’s SCADA system has undergone a revision, which has introduced a significant delay in its response to the reactive power setpoint values given by the controller. The response time changed from being almost immediate (in the order of seconds) to be several minutes, resulting in oscillations that are even worse than in the first test. Further investigation is currently going on regarding this issue.

## 6. CONCLUSION

The first conclusion to draw is that reactive power control by CHP plants appears to be a feasible way to contribute to the reactive power balance between distribution grids and the transmission system. This has been validated in simulations including a generic distribution network model, and in real-life implementation including a smaller section of a network, and fewer generators. It is important to underline that this has been implemented only by introducing a communication gateway in the CHP plant. No changes have been made to the substation, the grid operator's SCADA system, or the CHP plant in general. Consequently, a large-scale implementation of this setup only requires more communication gateways in other CHP plants.

Regarding the demonstration setup, a number of issues have been discovered that need further improvement. Most significant is the problem with deadbands and delays in the measurements of the reactive power exchange as well as in the setpoint response from the generators. With the conditions detected in this demonstration, a reasonable value for the controller update interval is suggested to be 5 minutes.

Alternatively, the CHP plants would have to respond much faster to a new setpoint. In this connection it is worth considering, if the controller could adjust the excitation setpoint directly, and thereby override the internal control loop on the plant that does this based on the reactive power setpoint. It simplifies the command path significantly. Also the reactive power exchange measurement could be improved significantly. This is currently going through the grid operator's SCADA system, and a more direct path could be introduced by equipping the substation with a communication interface that supports several clients, like IEC 61850 for substations. In a future scenario, this is not unlikely to be the case.

Looking ahead, there are other interesting aspects of the topic that become relevant if a large number of CHP plants are equipped with communication gateways, and at the same time substation information will be more readily available. For example, the CHP plants could be utilized to optimize the operation of the grid internally, and not only contribute to the external balance, and contribute to e.g. loss minimization or voltage control. Another field that must be investigated is how the CHP plant owners should be remunerated for their services. The CHP plants that are relevant for this concept are independent companies, that are already trading the electricity they generate in the electricity markets, and if they become capable of supplying other services, like reactive power, they will clearly expect remuneration. To address this, a market-based control concept may be feasible, which is a topic of future research.

## BIBLIOGRAPHY

- [1] IEC TC 57, "IEC 61850-7-420, Communication networks and systems for power utility automation – Part 7-420: Basic communication structure – Distributed energy resources logical nodes".
- [2] ABB's high voltage cable unit in Sweden "XLPE Underground Cable Systems, User's guide" (rev. 3, available online at [www.abb.com/cables](http://www.abb.com/cables))

# ***B*** **COMMUNICATION SYSTEMS FOR DISTRIBUTED ENERGY RESOURCES - A DEMONSTRATION OF IEC 61850-7-420**

---

This paper has been submitted for publication in the international journal Computer Standards and Interfaces.



# Communication systems for distributed energy resources - A demonstration of IEC 61850-7-420

\*Preben Nyeng<sup>a</sup>, Jacob Dall<sup>b</sup>, Claus Amtrup Andersen<sup>b</sup>

a:  
Technical University of Denmark  
Centre for Electric Technology  
DTU Building 325  
DK-2800 Lyngby  
Denmark

b:  
EURISCO ApS  
Forskerparken 10  
DK-5230 Odense M  
Denmark

\*: Corresponding author, email: [pany@elektro.dtu.dk](mailto:pany@elektro.dtu.dk), telephone +45 45 25 34 95

## Abstract

We have implemented and tested the recently released standard for communication with distributed energy resources, IEC 61850-7-420. The implementation is based on a realistic case with the purpose to assist the local grid operator in controlling voltage and reactive power flow in the grid. For this purpose, the integration with other parts of the power system is essential. In this paper we introduce the standard and its relation with other IEC standards, and describe the details of the overall information flow, and the design and implementation phases. Finally we point out some of the hurdles to overcome for the new standard to become a success.

## Keywords

IEC 61850; Communication systems; Distributed Energy Resources

## 1. Introduction

To support a further propagation of distributed energy resources (DER) in the electric power system, they must be involved as a stabilizing element in the system to a larger extent than today. This may include the delivery of ancillary services, the support of the system during operational disturbances or entirely new ways of structuring DER. A coherent information and communication system ensuring a close integration of the DER units with the rest of the power system is required to utilize the full potential of DER in the electric power system. As the need for communication grows, so does the need for standardization of the information structures and communication interfaces.

IEC 61850 is an effort in that direction. It was initially developed for communication between devices in power system substations and is currently being extended to include communication between power system components and the control room. It is a comprehensive, layered standard that includes object-oriented information models for substation devices [4,5], an abstract communication service interface, ACSI [3], and the framework for mapping the ACSI to lower level communication protocols [2]. In addition, it includes a specific communication service mapping (SCSM) to MMS (Manufacturing Message Specification) [8], an OSI 7-layer model compatible communication system used in industrial automation [9,10]. An illustration of some parts of the standard in relation to the OSI model is shown in figure 1.



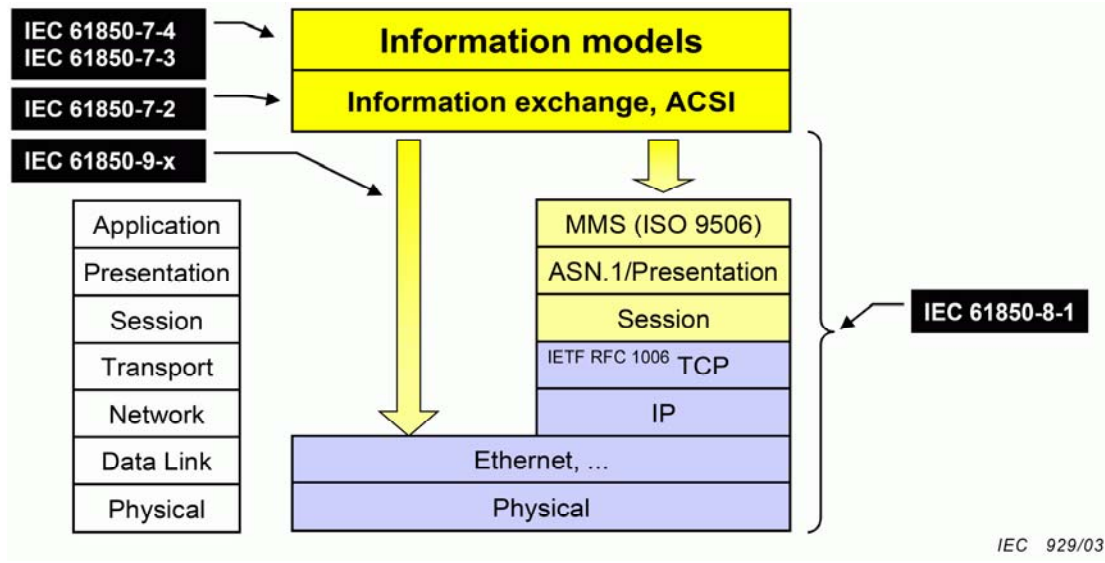

Figure 1: Some parts of IEC 61850 in relation to the OSI 7-layer model [2].

The core of the IEC 61850 information model are the Logical Nodes (LNs) which are a set of classes representing either physical components, such as circuit breakers, generators etc., or virtual entities, such as operational status and modes of control. LN instantiations may be logically grouped in Logical Devices (LDs), for example a generator and its auxiliary equipment and measurements that may be grouped in one LD.

Each LN contains a number of Data objects, each having a number of Data Attributes. The structure of an example information model based on logical nodes is shown in figure 2.

Based on this general structure of IEC 61850, a series of additions or related standards extend the use of the standard to other subdomains of the electric power system. Some, like IEC 61400-25, extend both the information model (the logical nodes), in this case to include wind turbines and their internal components, and additionally suggests other communication service mappings – e.g. web services – as alternatives to MMS. Others, like IEC 61850-7-410 and IEC 61850-7-420, are merely extensions of the IEC 61850 information model to include hydro power plants and distributed energy resources, respectively.

The latter has recently been published in edition 1.0. To investigate the applicability of this new standard to distributed energy resources, we have designed a case for communication between a typical example of DER equipment – a combined heat and power plant (CHP) – and the operator of the local power grid. The communication is implemented using the service and information models of IEC 61850 including the MMS mapping, and the specific DER extensions to the information model in IEC 61850-7-420. The work was carried out prior to the release of the standard, and as a result, input has been provided to the standardization group. A detailed description of the test case, the chosen information model, and software and hardware implementation is given in the following sections.

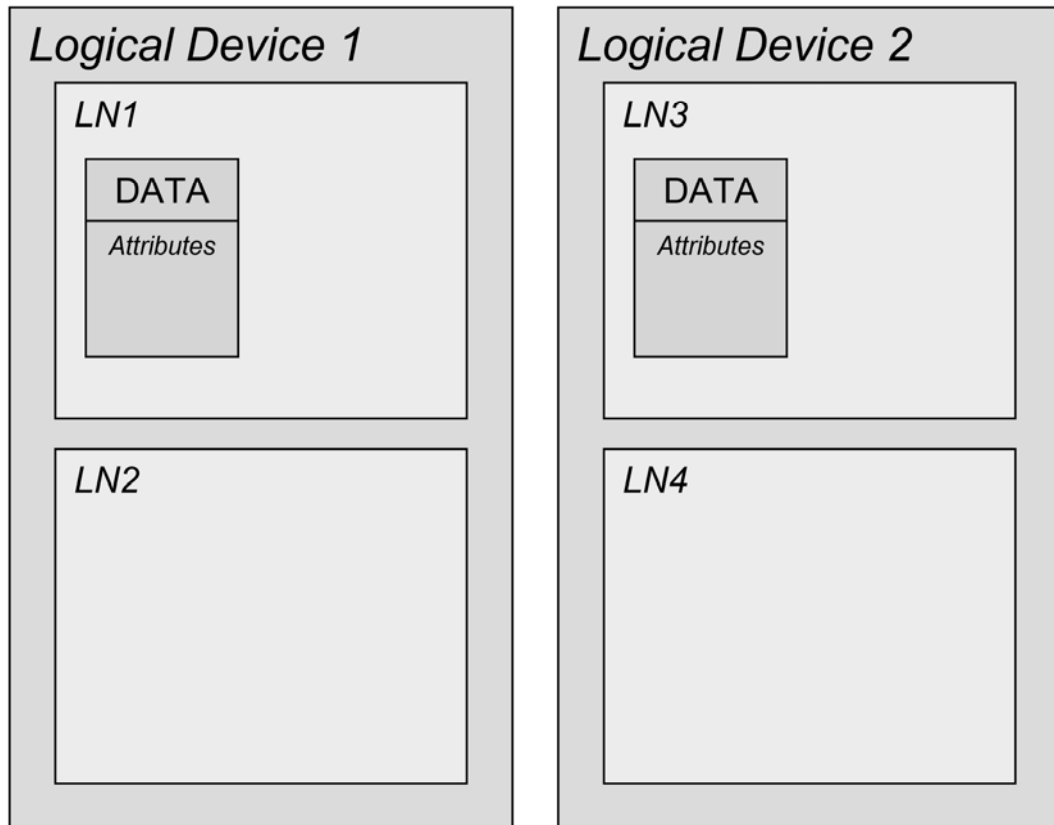

Figure 2: Relationship between Logical Devices, Logical Nodes and Data objects.

## 2. System description

Control of voltage and reactive power flows in distribution grids is of increasing concern of distribution grid operators (grid companies). As distributed generation is installed in the grids, maintaining the voltage within acceptable limits becomes a challenge. Traditionally, the voltage is assumed to drop along passive feeders and proper planning of the grid can assure an acceptable voltage profile. But when distributed generation, such as a CHP plant, raises the voltage locally, the need for active voltage control by reactive power compensation arises. In addition, there may be constraints on the exchange of reactive power with the higher level systems, which further increases the need for controlling the reactive power on as many resources as possible.

The theoretical aspects of reactive power and voltage control in distribution grids have already been investigated, such as in [11] and [12]. They both conclude that the distributed energy resources, if controlled properly, can play an important role in securing reasonable reactive power flows and voltage profiles. A thorough description of the problem is outside the scope of this paper, but to illustrate the use of IEC 61850-7-420 in a real-life situation, we have designed a controller that utilizes the reactive power generation capability of a CHP plant to achieve a certain reactive power flow in the nearby transformer station.

An overview of the system is shown in figure 3. The reactive power flow is measured in the 60 kV to 10 kV transformer. If it changes outside a predefined margin

(deadband) the value is transmitted on a dedicated line to the control center that is in charge of the grid operation. This setup is part of the existing SCADA system of the grid operator. From the control center, the value is transmitted in a flat file format via FTP to the controller in charge of the reactive power control of the CHP plant. This controller is at a geographically separate location and the FTP solution is chosen to avoid the need for modifications in the substation automation and communication systems.

Based on the reactive power measurement and the setpoint, the reactive power generation on the CHP plant is controlled via an IEC 61850 link. To avoid severe modifications in the plant's SCADA system, the IEC 61850 interface is implemented in the plant in a separate device (the "gateway"), that is hard-wired to the plant's SCADA system.

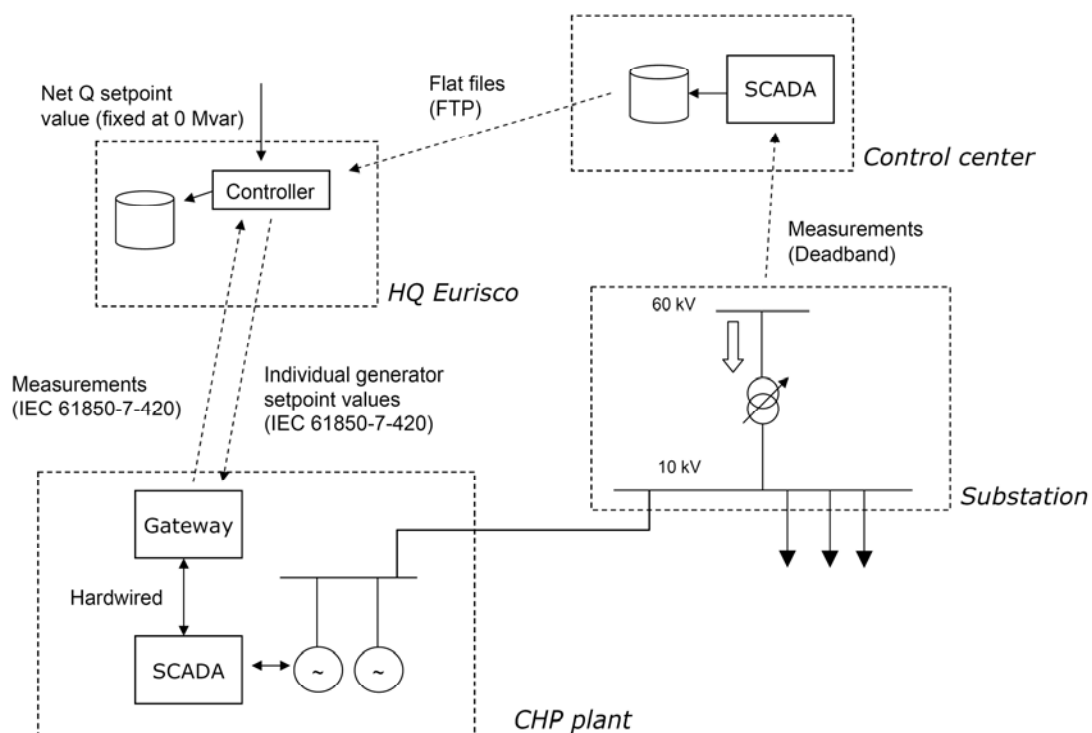

Figure 3: System overview.

### 3. Information model

An important part of IEC 61850 and its derivatives is the concept of information modeling – the design of a coherent virtual model of a real-world unit, put together using predefined Logical Nodes and their attributes. In order to design a good information model of the considered CHP plant, the functional requirements for the control system are analyzed in the following sections.

#### 3.1. Modes of operation

In general, there are many different ways of operating a CHP plant like the one considered in this project. It is a complex device that is limited in operation by the demands and boundaries in both the electric power system and the district heating system to which it supplies heat. The information model designed in this project is not

a comprehensive model that covers all aspects of the operation of a CHP plant – focus is on the test case, which is to control the reactive power.

The reactive power control is strongly correlated with the real power generation on the plant. The plant is operated by staff on the plant with the purpose to achieve the highest payment for its real power whilst fulfilling the heat demand. Consequently, the plant is only available for reactive power control when the market conditions makes real power generation attractive, and the option to start or stop the plant on demand from the reactive power controller is therefore not present. On the other hand, as much information as possible about the availability of the plant should be given to the controller.

There are basically 3 mutually exclusive ways of controlling the reactive power on the plant. First, a setpoint value of the reactive power can be tracked on the plant. It means that regardless of changes in the real power generation, the plant's control system will try to maintain constant reactive power. Second, a power factor setpoint can be tracked, so that there is a constant ratio between real and reactive power. It means that changes in the real power generation will be reflected in the reactive power as well. Finally, a voltage setpoint can be tracked so that the plant will adjust its reactive power to obtain the desired voltage in the connection point. This operational mode has a risk of disturbing the operation of tap-changing transformers and other voltage control equipment, and is in general not advised or allowed in distribution grids.

### *3.2. Control and monitoring*

The controller must contain an algorithm that can control the net reactive power flow in the nearby transformer, using the reactive power control capabilities of the plant. A simple integral controller has been designed for that purpose. An obstacle is the latency and the deadband in the measured value, transferred from the grid operator's control center. Due to this, a similar deadband has been implemented in the controller, and the control loop interval has been made quite long.

Only one single CHP plant is used in the control, but the controller is designed to distribute the task on a number of plants. To do so, it must know the availability of each plant, i.e. whether or not the plant is running and synchronized with the grid, and not in the process of ramping up or down.

In addition to controlling the reactive power, a number of parameters should be monitored by the controller. The system must provide online information about critical operational parameters such as real and reactive power generation, the voltage at the electrical connection point, and currently activated operational mode and setpoint values. Besides these online values a number of static parameters are relevant, such as rated real and reactive power. The online values must be stored in a log for later reference.

### *3.3. Resulting information model*

Based on the above analysis, a number of concrete parameters and functions have been identified and their corresponding representation in the Logical Nodes is determined, as listed in table 1. Subsequently the complete information model is put

together by selecting appropriate Logical Nodes arranged in a number of Logical Devices. The information model is outlined in figure 4.

#### 4. Server implementation

The server (gateway) is implemented on an industrial PC platform, Simatic Microbox, running an embedded version of Microsoft's Windows operating system. The gateway is hardwired to the plant's SCADA system through analog and digital input and output modules, connected to a Profibus interface on the PC. An overview of the overall server structure and its connections is illustrated in figure 5.

The gateway software consists of a main program, written in ANSI C, that is configured through a number of configuration files. This structure generally provides a very flexible way of adapting the server software to new applications, or future standard updates. The structure and the most important configuration files are described in the following sections.

Value or command	IEC 61850 Logical node and attribute < LN class > . < Attribute name >
<i>Data to server (setpoint values and commands)</i>	
Set operational mode: Reactive power setpoint tracking	DOPM.OpModConVar
Reactive power setpoint	DRCC.OutVarSet
Set operational mode: Power factor setpoint tracking	DOPM.OpModConPF
Power factor setpoint	DRCC.OutPFSet
Set operational mode: Voltage control	DOPM.OpModConV
Voltage setpoint	DRCC.OutVSet
<i>Data from server (status and measured values)</i>	
Real power generation	MMXU.TotW
Reactive power generation	MMXU.TotVAr
Operational status (running)	DRCS.ModOnCon (and others)

Table 1: Most important data in the information model, and the corresponding representation in Logical Nodes. DOPM is used to control the operating mode of the plant at the electrical connection point, DRCC is used for specific control actions on each unit, DRCS is used for status information, and MMXU represents measurements.

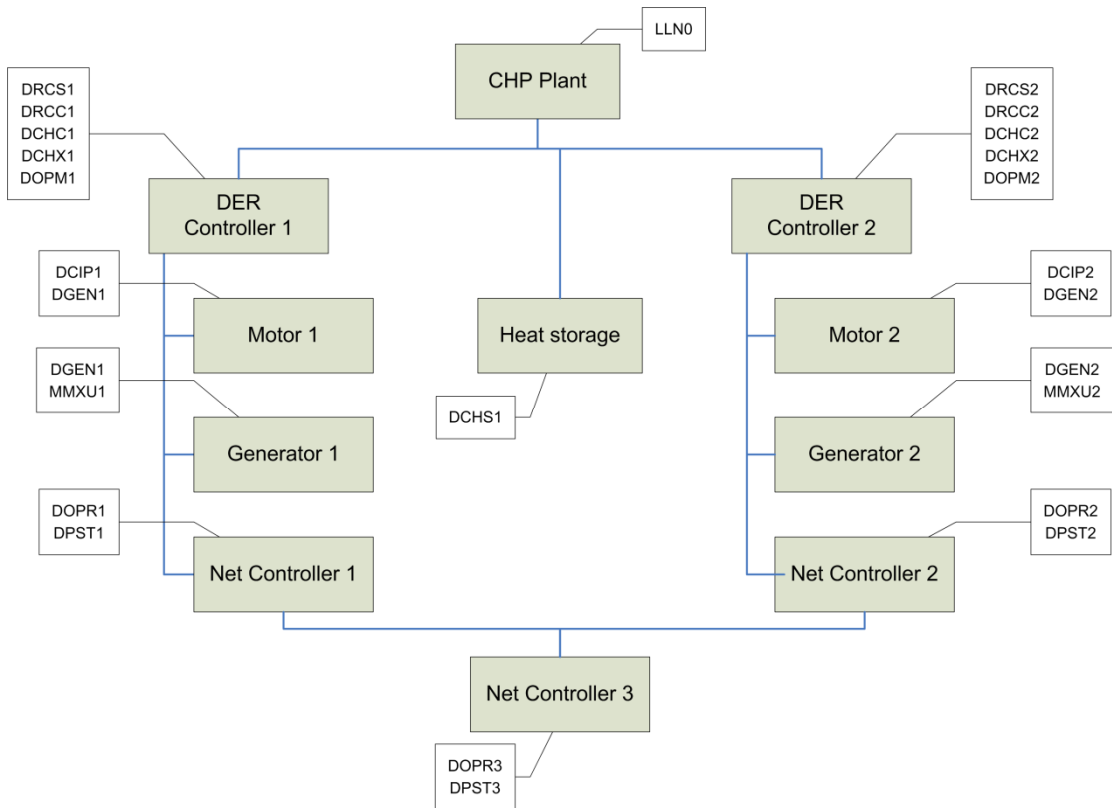

Figure 4: Overview of information model and relation between logical nodes and physical units.

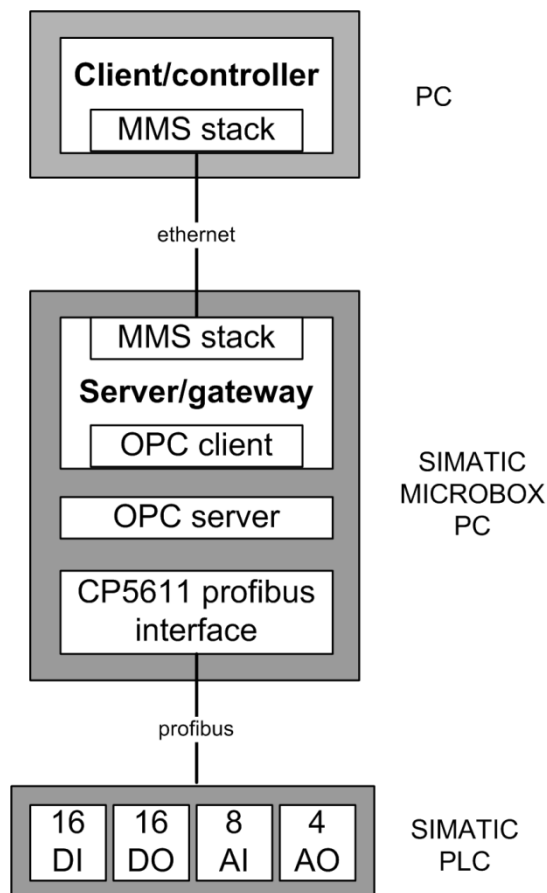

Figure 5: Server overview.

#### 4.1. Information model configuration

The information model is setup using a configuration file, written in the configuration description language SCL, specified in IEC 61850-6 [1]. SCL is an XML-based language that can be validated using an XML schema. This allows for a flexible configuration of the information model and a design-time validation of the configuration. In addition, when new editions of the information model classes are released, the SCL can easily be revalidated and revised to follow changes in the standard.

The SCL configuration file specifies the structure of the information model, but does not specify what happens when an attribute is read or written. To do so, a scripting engine is implemented in the gateway, so that any action taken when an attribute is read or written is configurable by the user through a script. To allow the use of generic script functions, e.g. an analog write, a mapping file is used to configure which attributes map to which script functions. The relation between the information model structure, the script functions, and the mapping between them is shown in figure 6.

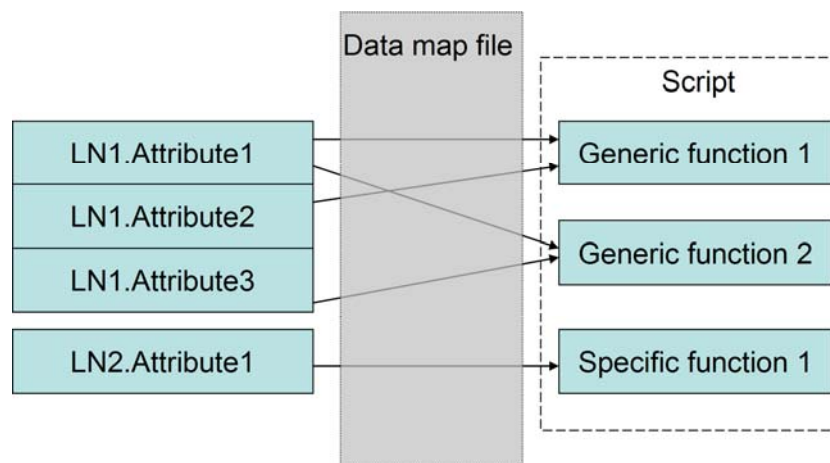

Figure 6: Illustration of the data map (DM) configuration file in relation to the information model and the script functions.

#### 4.2. Scripting

The scripting language used in the server application is called PAWN.

PAWN is a simple, typeless, 32-bit language with a C-like syntax. Execution speed, stability, simplicity and a small footprint were essential design criteria for both the language and the interpreter/abstract machine that a PAWN program runs on.

The PAWN language was designed as a flexible language for manipulating objects in a host application. The tool set (compiler, abstract machine) is written so that they are easily extensible and will run on different software/hardware architectures.

PAWN lacks a comprehensive library with standard functions, but provides a general purpose means of using, extending and combining the specific “native” functions that is needed by scripts being executed by the VM. New features are added simply by loading a module that provides the required functions.

Whenever the gateway server must perform an I/O operation initiated by a MMS operation, it calls upon the PAWN virtual machine for help with performing the necessary steps. The server does not in any way filter the information regarding the operation, but simply forwards all available information to the scripting function executed by the VM. Hence the server has no influence on what will, or will not happen, when control is transferred to the scripting engine.

Any kind of data can be accessed, provided the appropriate function module has been loaded. As an example, in this project, an OPC client module was implemented, allowing a script to access data provided by an OPC server. Besides specifying what should happen upon an I/O request, the script can opt to perform IED specific initialization.

#### 4.3. Communication services

The services described in the Abstract Communication Service Interface description [3] are implemented in the gateway. They are mapped to MMS according to IEC 61850-8-1 [8]. The MMS stack is a commercially available product, provided by SISCO.

Only a subset of the services described in the standards are implemented, namely the ones used in relation to this project. A list of implemented services and their purpose is shown in table 2.

### 5. Client implementation

To implement the closed-loop control depicted in figure 3, a client application has been developed that implements the controller, monitoring, and an IEC 61850 compliant communication link to the gateway in the CHP plant. To allow the re-use of functionality of the client in future research projects, the ACSI and MMS related functions have been wrapped in separate compiled libraries.

<i>Service name</i>	<i>Description</i>
Associate	Create a server connection
Release	Close a server connection
GetServerDirectory	Retrieves a list of names of a logical device or file within a server
GetLogicalDeviceDirectory	Retrieves a list of object refs of logical nodes within a logical device
GetLogicalNodeDirectory	Retrieves a list of object refs of all instances of a class within a logical device
GetDataValues	Retrieves a list of data attribute values of a data within a logical node
SetDataValues	Writes values of data attributes of a data within a logical node
GetBRCBValues	Get values controlling buffered reporting
SetBRCBValues	Set values controlling buffered reporting

Table 2: Overview of implemented ACSI services.



### *5.1. Logging*

The client application uses a SQLite database to store historical data values. Data is retrieved from the power plant by means of the buffered reporting service according to IEC 61850. The content of these reports are the source of the data stored in the historical database.

When the client connects to the gateway, it enables a set of predefined reports in order to be notified whenever one of the status signals or measurements needed for the control loop changes state or value.

The predefined reports are setup as buffered, meaning that if the gateway due to a communication failure is unable to deliver the report, it will buffer it locally and send it later when the connection to the client has been re-established.

### *5.2. Control center data*

Data about the substation is received from the grid operator's control center in flat files over an FTP connection. This solution was chosen to eliminate the need for modifications in the substation's automation system, and in the grid operators control center.

The only value necessary to perform a basic control of the reactive power is the net reactive power flow in the transformer, but in addition to that, a number of diagnostic parameters are included in the data set, such as voltages and other real and reactive power flows in the substation. These values are stored in the client's database for subsequent analysis.

## **6. Conclusion**

The implementation of the IEC 61850 server and client is now completed and the hardware is installed and operational on site. The closed loop control has been used to test the system during normal power plant operation. Results show that the communication link works satisfactory but there is currently an unresolved issue on latency in the CHP plant's response to a new setpoint. A detailed analysis of this problem is currently undertaken, but this is outside the scope of this paper.

Implementing a communication system for a distributed energy resource in compliance with IEC 61850-7-420 has been a tedious task. The standard itself is very comprehensive and the mapping to MMS either makes the implementation time even longer or makes the implementation reliant on third-party commercial MMS implementations, which are only available from a very limited number of providers. Web services are suggested as an alternative mapping in IEC 61400-25, but this option will due to the nature of HTTP requests and responses, limit the functionality of the service model. In addition, the web services mapping requires more resources in the gateway and has a larger communication overhead. The obvious advantage of web services is the availability of numerous open source tools that can shorten the development time, and the native support for web services on many server platforms.

On the information modeling side, the standard provides a toolbox of classes, but does not specify how they should be combined to model a specific device. That is a strong point of the standard, because it matches the inhomogeneous characteristics that distributed energy resources very often have. In this way it is possible to model

virtually any new device, using familiar building bricks. On the other hand, it means that from the point of view of a grid operator that interfaces to possibly thousands of devices, there is no certainty that any two devices will have the same information model – even though many devices may be very alike or even identical. As a consequence the grid operator will still have to consider each case individually. If some “pre-build” information models for typical device setups were included in the standard, this problem would be reduced.

Finally it is worth mentioning that many of the obstacles in this implementation, in particular when designing the overall communication system, would have been much smaller if relevant standards had already been more widely adapted. One concrete example is the retrieval of information from the subsystem that is done via FTP transfers of exported data files from the control center. In a future scenario, this interface would either have been standardized in IEC 61970 (Energy management system API), or in a more service oriented architecture the information could have been retrieved directly by the controller from the substation with IEC 61850 for substations. Another example is the use of hard-wiring between the gateway and the CHP plant’s control system, which calls for additional A/D and D/A converters, and related interfaces. To eliminate this issue, the communication standard should be implemented in the control system of the plant itself, and not as an additional separate interface extension. We think it is evident from our experience with this project, that though IEC 61850’s advantages and disadvantages can be discussed, the adaptation of a well-functioning communication standard for DER is vital to the further extension of DER control in the electric power system.

## References

1. IEC 61850-6, Communication networks and systems in substations - Part 6: Configuration description language for communication in electrical substations related to IEDs.
2. IEC 61850-7-1, Communication networks and systems for power utility automation – Part 7-1: Basic communication structure – Principles and models.
3. IEC 61850-7-2, Communication networks and systems for power utility automation – Part 7-2: Basic information and communication structure – Abstract communication service interface(ACSI).
4. IEC 61850-7-3, Communication networks and systems for power utility automation – Part 7-3: Basic communication structure – Common data classes.
5. IEC 61850-7-4, Communication networks and systems for power utility automation – Part 7-4: Basic communication structure – Compatible logical node classes and data classes.
6. IEC 61850-7-410, Communication networks and systems for power utility automation – Part 7-410: Hydroelectric power plants – Communication for monitoring and control.

7. IEC 61850-7-420, Communication networks and systems for power utility automation – Part 7-420: Basic communication structure – Distributed energy resources logical nodes.
8. IEC 61850-8-1, Communication networks and systems for power utility automation – Part 8-1: Specific Communication Service Mapping (SCSM) – Mappings to MMS (ISO 9506-1 and ISO 9506-2) and to ISO/IEC 8802-3.
9. ISO 9506-1, Industrial automation systems - Manufacturing Message Specification – Part 1: Service definition.
10. ISO 9506-2, Industrial automation systems - Manufacturing Message Specification – Part 2: Protocol specification.
11. Torsten Lund, Analysis of distribution systems with a high penetration of distributed generation, PhD dissertation, Technical University of Denmark, Denmark, 2007
12. Ferry August Viawan, Voltage Control and Voltage Stability of Power Distribution Systems in the Presence of Distributed Generation, PhD dissertation, Chalmers University of Technology, Sweden, 2008

**Preben Nyeng** received his MSc degree from the Technical University of Denmark (DTU) in 2000. After that he worked for 6 years in a private company with the design and implementation of embedded systems, interfaces, and associated database systems. Since 2006, he has been with the Centre for Electric Technology at DTU, pursuing a PhD degree in the area of intelligent energy systems, and related information and communication technology.

**Claus Amtrup Andersen** graduated from OTS, Denmark in 1993 with a degree in embedded hardware and software design. He has worked as a Manager for EURISCO since 1994. EURISCO has since 2003 worked with data communication for Distributed Energy Resources and Claus Amtrup Andersen is active member of IEC TC57 WG17 and IEC TC69 WG4.

**Jacob Dall** started his career in 1988 at Thorsted Maskiner A/S and enlisted in the Danish forces in 1990/1991. He graduated from OTS, Denmark in 1993 with a degree in embedded hardware and software design and has worked as a Chief development Officer for EURISCO since 1994.

# C

## **COORDINATED MULTI-OBJECTIVE CONTROL OF REGULATING RESOURCES IN MULTI-AREA POWER SYSTEMS WITH LARGE PENETRATION OF WIND POWER GENERATION**

---

This paper was published in the Proceedings of the 7th International Workshop on Large-Scale Integration of Wind Power into Power Systems, 26-27 May, 2008, Madrid, Spain



# Coordinated Multi-Objective Control of Regulating Resources in Multi-Area Power Systems with Large Penetration of Wind Power Generation

Preben Nyeng, Bo Yang, Jian Ma, Yuri Makarov, John H. Pease, David Hawkins, and Clyde Loutan

**Abstract**—This paper describes a control algorithm for a Wide Area Energy Storage and Management System (WAEMS). The WAEMS is designed to meet the demand for fast, accurate and reliable regulation services in multi-area power systems with a significant share of wind power and other intermittent generation. The means are utilization of flywheel energy storage units, hydro power generation, and energy exchange among the participating control areas.

The objective of the control algorithm is to respond to the control signals from the different system operators, whilst optimizing the hydro power plant operation by reducing the tear and wear on the mechanical parts and improving the energy efficiency of the plant.

The performance of the WAEMS is simulated using a mathematical model, including hydro power plant and flywheel energy storage models. ACE measurements from the California ISO and Bonneville Power Administration control areas are used as control signals to the WAEMS.

Simulations demonstrate excellent regulation response and break-through results in terms of improved hydro power plant operation.

**Index Terms**—Control, wind power, regulation, power systems, linear programming, quadratic programming

## I. INTRODUCTION

The Bonneville Power Administration (BPA) and California ISO (CAISO) both expect a significant increase of wind power penetration in their respective service areas within near future. Studies have shown that the increased wind power penetration will require additional regulation and load-following capacity [1]-[3].

To mitigate the increased demand for regulation capacity, a Wide Area Energy Storage and Management

The work has been funded under the Bonneville Power Administration Technology Innovations contract # BPA00028087/PNNL52946. California ISO, the California Energy Commission, and Beacon Power Corporation contributed in kind to this project.

The Pacific Northwest National Laboratory is operated by Battelle for the U.S. Department of Energy under Contract DE-AC05-76RL01830.

P. Nyeng is with the Technical University of Denmark, Lyngby, Denmark (e-mail: pny@elektro.dtu.dk).

B. Yang, J. Ma, and Y. Makarov are with the Pacific Northwest National Laboratory, Richland, WA 99354 USA.

J. H. Pease is with the Bonneville Power Administration, Portland, OR 97232 USA

D. Hawkins and C. Loutan are with the California ISO, Folsom, CA 95630 USA

System (WAEMS) is proposed in a research project, recently conducted by the Pacific Northwest National Laboratory for the BPA [4]. The WAEMS will address the additional regulation requirement through the energy exchange between the participating control areas and through the use of energy storage and other generation resources.

The project develops principles, algorithms, market integration rules, functional design and technical specifications for the WAEMS system. In this paper, we propose a control algorithm to be used in the WAEMS, and present simulation results obtained using an integrated model of the control system and the participating units.

## II. SYSTEM DESCRIPTION

From the point of view of each of the participating control area operators, the WAEMS must react like any other regulation resource, i.e. respond to an automatic control signal, posted every 4 seconds.

A system overview is given in Fig. 1. The principle of the WAEMS is to summarize the regulation signals from each control area operator and coordinate the operation of the individual participating storage or generation resources to meet the requested total regulation output. Dynamic schedules are used to distribute the resources between participating control areas.

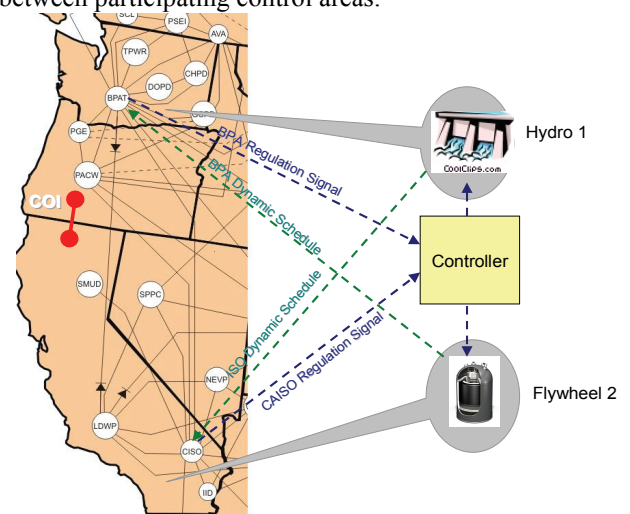

Fig. 1. Overview of the system concept.

### A. Participating units

The WAEMS is conceptually designed to work with many different generation and storage resources and many participating control areas. However for the initial simulations, a setup with 1 generation resource, 1 storage resource and 2 participating control areas is evaluated. The resources are selected to provide 20 MW of regulation each, i.e. a total of 40 MW of regulation.

The generation resource is a hydro power plant commonly found in the Northwestern U.S. No specific plant is chosen for the simulation, but typical values for e.g. response time and power capacity are used:

- Power range: 100 MW ... 400 MW
- Regulation service: -20 MW ... + 20 MW
- Energy capacity: Unlimited
- Response time (First order step response):
  - o 63% after 20 sec.
  - o 86% after 40 sec.
  - o 95% after 60 sec.

In the WAEMS project, numerous energy storage technologies have been evaluated. For reasons like reliability, fast response, and long cycle life, the flywheel technology has been chosen for the simulations. Further details about the evaluated storage technologies are published separately in [5].

The flywheel plant used in the simulations has the following characteristics:

- Power range: - 20 MW ... + 20 MW
- Energy capacity: 100% power for 15 min. = 5 MWh
- Response time: < 4 sec.
- Standby loss: 1.1%
- Roundtrip efficiency ~90 %

### III. SIMULATION MODEL

The simulation model is outlined in Fig. 2. It consists of several parts, integrated into a unified model. Each part is described in subsequent sections. Based on the input signal, a control algorithm determines the optimal distribution of the requested regulation on the participating units. The algorithm calculates setpoints for each unit, which are then supplied to the unit models. The outcome is time series of hydro power plant output, flywheel energy state, and flywheel power output.

Compared with the flywheel, the hydro plant has a significantly longer response time. To achieve a fast aggregated response to the regulation signal, the flywheel setpoint is modified dynamically to compensate for the hydro plant delays.

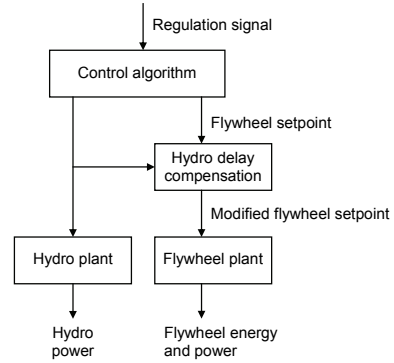

Fig. 2. Block diagram of the integrated simulation model.

### A. Control algorithm

The control algorithm seeks to find the optimal distribution of resources, satisfying 3 objectives:

1. Keep the hydro plant close to its most efficient point of operation (ideally  $\pm 1\%$ ). Deviations from this region of operation will reduce the efficiency of the hydro plant.
2. Maintain desired energy level in flywheel storage, depending on regulation service: up, down or both.
3. Supply the requested regulation service at all times.

The last objective should be met if at all possible, so mathematically it is expressed as a constraint. However if the constraint is violated (e.g. if the flywheel is depleted), an additional post-optimization step calculates a solution to ensure that the regulation service matches the input signal as close as possible.

The relative weight of objectives 1 and 2 has a significant influence on system behavior and must be chosen carefully. By changing this relative weight, the system can be designed to let either the flywheel or the hydro plant take a relatively larger share of the regulation task.

The optimization variables are  $X_{fw}$  and  $X_{hyd}$ , which denote the regulation power output from the flywheel and the hydro plant, respectively.

#### 1) Variable boundaries

Power output from, or input to, the flywheel is limited by the power converter and generator/motor:

$$P_{fw,min} \leq X_{fw} \leq P_{fw,max} \quad (1)$$

Furthermore the energy stored in the flywheel cannot go below a certain minimum value or exceed a certain maximum value during the following period of operation:

$$E_{fw,min} \leq E_{fw,next} \leq E_{fw,max} \quad (2)$$

The relation between energy and power is given by

$$E_{fw,next} = E_{fw} - X_{fw} \cdot \Delta t \quad (3)$$

which inserted into (2) gives:

$$\frac{E_{fw} - E_{fw,max}}{\Delta t} \leq X_{fw} \leq \frac{E_{fw} - E_{fw,min}}{\Delta t} \quad (4)$$

The hydro plant is similarly constrained by its physical upper and lower limits of power production:

$$P_{hyd,min} \leq P_{hyd} \leq P_{hyd,max} \quad (5)$$

The total power output from the hydro plant  $P_{hyd}$  is a

sum of the scheduled output and the regulation output:

$$P_{hyd} = P_{hyd,sch} + X_{hyd} \quad (6)$$

which inserted into (5) gives the limit for the regulation output:

$$P_{hyd,min} - P_{hyd,sch} \leq X_{hyd} \leq P_{hyd,max} - P_{hyd,sch} \quad (7)$$

In addition, the capacity reserved for regulation may have an upper and lower limit:

$$P_{hyd,cap,min} \leq X_{hyd} \leq P_{hyd,cap,max} \quad (8)$$

To summarize, the optimization variables  $X_{fw}$  and  $X_{hyd}$  are bound by the non-interdependent limits given by:

$$X_{fw,min} \leq X_{fw} \leq X_{fw,max}$$

$$X_{hyd,min} \leq X_{hyd} \leq X_{hyd,max}$$

$$X_{fw,min} = \max\left(P_{fw,min}, \frac{E_{fw} - E_{fw,max}}{\Delta t}\right) \quad (9)$$

$$X_{fw,max} = \min\left(P_{fw,max}, \frac{E_{fw} - E_{fw,min}}{\Delta t}\right)$$

$$X_{hyd,min} = \max(P_{hyd,cap,min}, P_{hyd,min} - P_{hyd,sch})$$

$$X_{hyd,max} = \min(P_{hyd,cap,max}, P_{hyd,max} - P_{hyd,sch})$$

## 2) Variable interdependent constraints

The total regulation performed by both units must match the regulation signal that is input to the control algorithm:

$$X_{fw} + X_{hyd} = RS \quad (10)$$

Due to the physical location of the units on each side of the California-Oregon Intertie, additional constraints are necessary when the intertie is congested to prevent overloading. However, such constraints are not considered in this model.

## 3) Objective function

To find the optimum distribution of resources, the problem is expressed as a minimization problem of an objective function, which consists of a weighted sum of objective functions for each objective:

$$\min_X F(x) = \min_X (F_{fw}(X_{fw}) + F_{hyd}(X_{hyd})) \quad (11)$$

Selecting the objective functions influences the solution technique used to calculate the optimum. We have evaluated linear programming and quadratic programming techniques and found the latter to give the best results, with no caveats in terms of computation time. Consequently, in the following and in the presentation of results, only the quadratic programming technique is considered.

The formulation of the flywheel objective function aims at maintaining the energy stored in the flywheel at a certain level,  $E_{fw,offset}$ . The deviation from this level in the next period of operation adds quadratically to the objective function value:

$$F_{fw} = a_{fw} (E_{fw,next} - E_{fw,offset})^2 \quad (12)$$

where  $a_{fw}$  is the weight factor of the flywheel objective function in the total objective function. Fig. 3 is a plot of the flywheel objective function.

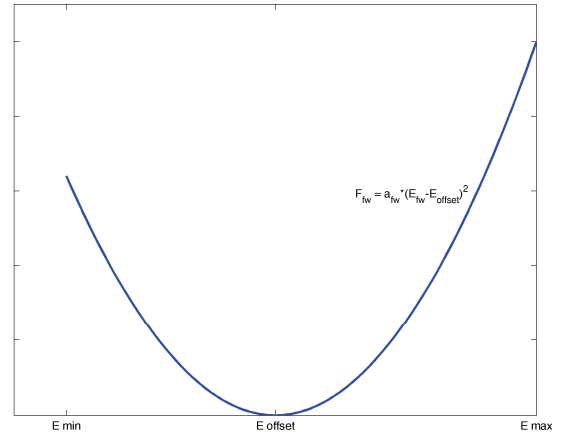

Fig. 3. Plot of flywheel objective function.

Since the optimization variable is power and not the energy, the objective function is written as a function of  $X_{fw}$  by inserting (3) into (12):

$$\begin{aligned} F_{fw} &= a_{fw} (E_{fw} - X_{fw}\Delta t - E_{fw,offset})^2 \\ &= a_{fw} ((E_{fw} - E_{fw,offset})^2 \\ &\quad + (X_{fw}\Delta t)^2 - 2(E_{fw} - E_{fw,offset})X_{fw}\Delta t) \end{aligned} \quad (13)$$

The hydro objective function is formulated to reflect the preferred operation at the most efficient power output setpoint. Deviation from the most efficient point of operation,  $P_{hyd,eff}$ , adds quadratically to the objective function value:

$$F_{hyd} = a_{hyd} (P_{hyd} - P_{hyd,eff})^2 \quad (14)$$

where  $a_{hyd}$  is the weight factor of the hydro objective function in the total objective function. Fig. 4 is a plot of the hydro objective function.

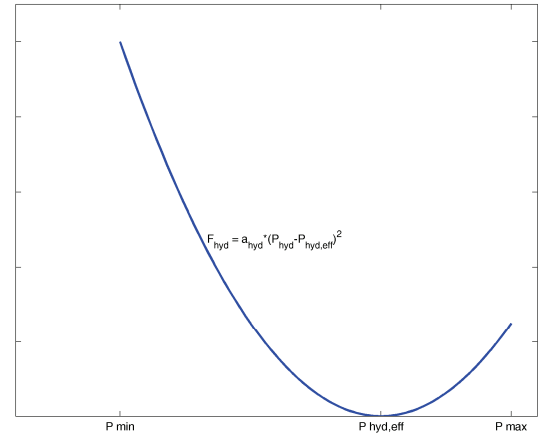

Fig. 4. Plot of hydro objective function.

The hydro objective function is rewritten as a function of the optimization variable  $X_{hyd}$  by inserting (6) into (14):

$$\begin{aligned} F_{hyd} &= a_{hyd} (P_{hyd,sch} + X_{hyd} - P_{hyd,eff})^2 \\ &= a_{hyd} ((P_{hyd,sch} - P_{hyd,eff})^2 \\ &\quad + X_{hyd}^2 + 2X_{hyd}(P_{hyd,sch} - P_{hyd,eff})) \end{aligned} \quad (15)$$

## 4) Global minimization

The global minimization problem is solved by minimizing the total objective function given by the sum of the objective functions in (13) and (15). The total



objective function may thus be written as:

$$F = \frac{1}{2} \cdot X \cdot H \cdot X^T + f^T \cdot X$$

with

$$X = \begin{bmatrix} X_{fw} \\ X_{hyd} \end{bmatrix} \quad (16)$$

$$H = \begin{bmatrix} 2 \cdot a_{fw} \cdot \Delta t^2 & 0 \\ 0 & 2 \cdot a_{hyd} \end{bmatrix}$$

$$f = \begin{bmatrix} -2 \cdot a_{fw} \cdot (E_{fw} - E_{fw,offset}) \cdot \Delta t \\ 2 \cdot a_{hyd} \cdot (P_{hyd,sch} - P_{hyd,eff}) \end{bmatrix}$$

### B. Flywheel Model

The flywheel model was initially developed and supplied by Beacon Power Corporation. For the model to be incorporated into the integrated model, outlined in Fig. 2, it has been converted to a MATLAB model by PNNL. The flywheel model includes charging and discharging losses, floating losses and auxiliary power as shown in Fig. 5.

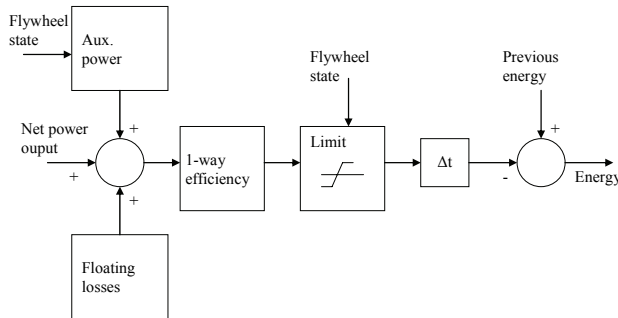

Fig. 5. Block diagram of the flywheel model.

### C. Hydro Model

The developed hydro power plant model is shown in Fig. 6. The model includes: delay block simulating the delay in the plant's response to the changing regulation signal; dead band element; first order plant response model; error range simulating deviations of the actual plant response from the load setting, and limiting element restricting the maximum and minimum regulation output provided by the plant.

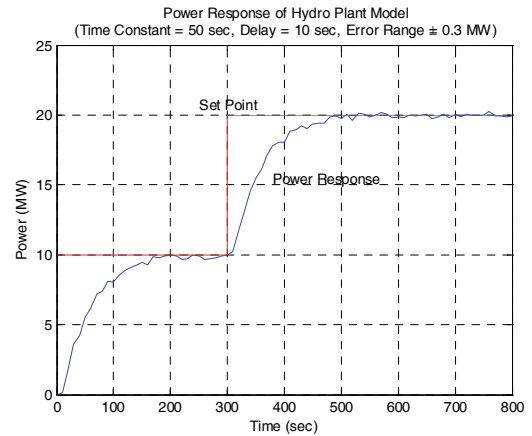
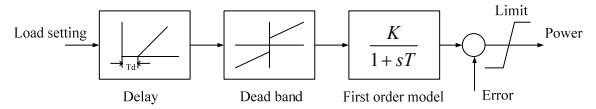

Fig. 6. Block diagram of the hydro model and a plot of a step response. In this plot a time constant of 50 seconds is assumed, but in the simulations in this paper a time constant of 20 seconds is used.

#### 1) Input Signal

Due to the limited availability of a real regulation signal, Area Control Error (ACE) signals are used as a substitute. A total of 36 days of 4-second data throughout a year were available for the simulation. The maximum period of consecutive data is 48 hours, and the results in this paper only treat a single 48 hour period. However similar results are obtained for other 24 hour or 48 hour periods.

The ACE data from each control area are added and the result is scaled to fit into the 40 MW range of up or down regulation.

## IV. RESULTS

Some results of the simulations are shown in this section. A simulation period of 48 hours is used. The three plots in Fig. 7 are a close-up on a shorter period to show the input signal and the resulting power outputs in detail. It is observed that the aggregate power output follows the input signal well, and that the hydro output curve is smoother than the flywheel output curve. In other words, the system in this simulation is tuned to let the flywheel react on the fast changes whereas the hydro plant reacts when the flywheel state of charge starts to offset from the desired energy level.

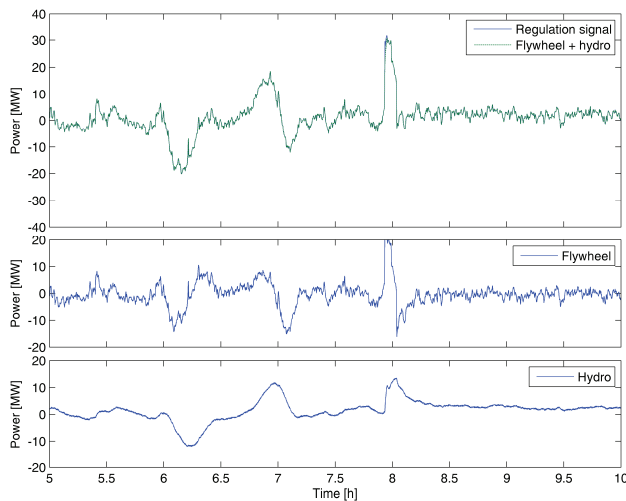

Fig. 7. Aggregate power output and input signal; flywheel power output; and hydro output.

The plots in Fig. 8 show the output from the hydro plant together with the boundaries of the region considered the most efficient operating range. Operation outside this region is reduced from 10.8 to 5.2 hours with the proposed control algorithm. Furthermore the plot shows a much smoother curve for the hydro output with much less frequent changes.

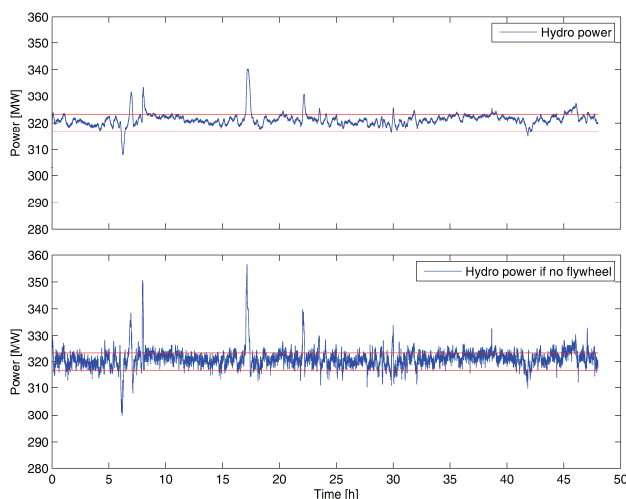

Fig. 8. Hydro power output and hydro power output if there was no flywheel. Both compared with the most efficient region of operation.

Finally, in Fig. 9, the state of charge of the flywheel is observed. The flywheel is fully depleted in a total of 7 minutes during the simulation period.

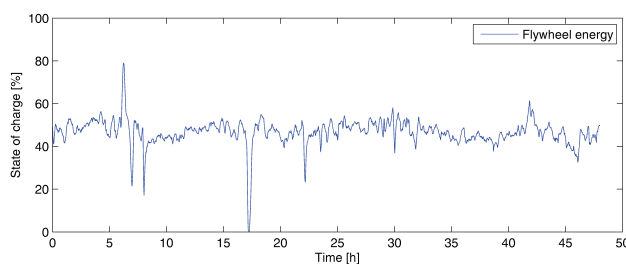

Fig. 9. Flywheel state of charge

## V. CONCLUSION

Simulation results clearly demonstrate feasibility and efficiency of the proposed Wide Area Energy Management and Energy Storage system. The aggregated hydro power plant and flywheel storage plant provides a faster and more accurate regulation service, than that of the hydro plant alone. This is because the flywheel compensates for the inaccuracies caused by the response delay, dead zone, and deviation characteristics of the hydro power plant.

The use of the flywheel energy storage can be tuned to make the hydro power plant regulation curve shallower and smoother. This would help to minimize the wearing and tearing problem on the participating hydro power plant. Additionally, the flywheel helps to keep the hydro power plant output closer to the most efficient operating point. By a proper selection of the hydro and flywheel weight factors in the objective function, the hydro power plant operating point can be kept within the 1% deviation range from the most efficient point most of the time.

The hydro power plant is capable of holding the flywheel's state of charge closer to the selected offset point whenever it is possible and prevent failures in following the regulation requirement when the flywheel exhausts its energy regulation range. By a proper selection of the flywheel's energy offset, the flywheel energy can be adjusted to efficiently use the entire available energy range and minimize the number of violations. This energy offset adjustment does not noticeably alter the flywheel and hydro power plant performance.

## VI. ACKNOWLEDGMENT

Thanks to Carl Miller and Shuai Lu, both PNNL, for their valuable contribution on the flywheel and hydro power plant Matlab models.

## VII. REFERENCES

- [1] C. Loutan and D. Hawkins, "Integration of Renewable Resources: Transmission and Operating Issues and Recommendations for Integrating Renewable Resources on the California ISO-Controlled Grid," CAISO Report November 2007.
- [2] Y. V. Makarov, C. Loutan, J. Ma, P. d. Mello, and S. Lu, "Evaluating Impacts of Wind Generation on Regulation and Load Following Requirements for Integrating Intermittent Resources," in WINDPOWER 2008 Houston, TX, June 1-4, 2008.
- [3] Y. V. Makarov, S. Lu, B. McManus, and J. Pease, "The Future Impact of Wind on BPA Power System Ancillary Services," in WINDPOWER 2008 Houston, TX, June 1-4, 2008.
- [4] Y. V. Makarov, B. Yang, J. DeSteele, S. Lu, C. Miller, P. Nyeng, J. Ma, D. Hammerstorm, and V. Viswanathan, "Wide-Area Energy Storage and Management System to Balance Intermittent Resources in the Bonneville Power Administration and California ISO Control Areas," PNNL Project Report December 2007.
- [5] B. Yang, Y.V. Makarov, J. DeSteele, V. Viswanathan, P. Nyeng, B. McManus, and J. Pease, "On the Use of Energy Storage Technologies for Regulation Services in Electric Power Systems with Significant Penetration of Wind Energy", the 5<sup>th</sup> International Conference on the European Electricity Market, May 28-30, 2008.

## VIII. BIOGRAPHIES

**Preben Nyeng** received his M.Sc. in Engineering from the Technical University of Denmark in 2000. From 2000 to 2006 he was a development engineer at Logos Control Systems, Denmark. He is currently pursuing the PhD degree at the Center for Electric Technology at the Technical University of Denmark. From August to December 2007 he was a visiting researcher at the Pacific Northwest National Laboratory, Richland, Washington.

**Bo Yang** (S'03) received the M.S. from Shanghai Jiaotong University, Shanghai, China, in 2003 and Ph.D. from Arizona State University in 2007. She is currently a research scientist at the Pacific Northwest National Laboratory, Richland, WA. Her research interests are in the area of power system dynamics and control.

**Yuri V. Makarov** received his M. Sc. degree in Computers and Ph.D. in Electrical Engineering from the Leningrad Polytechnic Institute (now St. Petersburg State Technical University), Russia. From 1990 to 1997 he was an Associate Professor at the Department of Electrical Power Systems and Networks in the same University. From 1993 to 1998 he conducted research at the University of Newcastle, University of Sydney, Australia, and Howard University, USA. From 1998 to 2000 he worked at the Transmission Planning Department, Southern Company Services, Inc., Birmingham, Alabama as a Senior Engineer. From 2001 to 2005 he occupied a senior engineering position at the California Independent System Operator, Folsom, California. Now he works for the Pacific Northwest National Laboratory, Richland, WA. His activities are around various theoretical and applied aspects of power system analysis, planning and control. He participated in many projects concerning power system transmission planning (power flow, stability, reliability, optimization, etc.) and operations (control performance criteria, quality, regulation, impacts of intermittent resources, etc.). He was a member of the California Energy Commission Methods Group developing the Renewable Portfolio Standard for California; a member of the Advisory Committee for the EPRI/CEC project developing short-term and long-term wind generation forecasting algorithms, and a voting member of the NERC Resources Subcommittees and NERC Wind Generation Task Force. For his role in the NERC August 14th Blackout Investigation Team, he received a Certificate of Recognition signed by the US Secretary of Energy and the Minister of Natural Resources, Canada.

**Jian Ma** received the B.S. degree from Shandong University, and the M.S. degree from Dalian University of Technology, China, in 1996 and 1999 respectively. He will receive his Ph.D. degree in Electrical Engineering from The University of Queensland, Australia in June 2008. From 1999 to 2004, he worked as a Research Engineer and Senior Programmer at electrical power R&D companies in China, focusing mainly on EMS/SCADA/DTS. From 2004 to 2005, he conducted research in the School of Mechanical and Aerospace Engineering at Nanyang Technological University, Singapore. From April 2007 to present he has been a visiting research fellow at Pacific Northwest National Laboratory (PNNL), Richland, WA. His research interests include power system stability and control, power system security assessment, and artificial intelligence application in power systems.

**John Pease** started with Bonneville Power Administration in 1988 as a system protection engineer from 500kV to 69kV. From 1992 to 1998 he was with the BPA Laboratories, working with innovative protection and control schemes at 500kV. In 2001 he became a project manager in the Renewable Energy group for BPA Power, evaluating 26 wind projects as part of BPA's 1000 MW RFP. In 2005 he became the manager of BPA's Wind Forecasting Network, the first forecast system to predict hourly wind energy from real time to seven days in advance. In 2006, John became a project manager for Technology Confirmation and Innovation (TC/I) group at BPA, evaluating 26 wind, wave, tidal and energy storage projects as part of a 2007 RFP, managing 10 projects selected for funding. In 2008 he is managing five projects; one is the PNNL Wind Regulation & Load Following project for the integration of 3000 MW wind by 2009, and the Wide Area Energy Storage system that will assist balancing the BPA and California ISO control areas in real time. Recent achievements: Chairman, Portland Chapter of the IEEE Power Engineering Society, 1999 to 2002; IEEE-USA Professional Achievement Award in 2002. Education: BSEE University of Wyoming (1988), MBA, Portland State University (2001), Professional Engineer, State of Washington.

# ***D*** **INFORMATION AND COMMUNICATIONS SYSTEMS FOR CONTROL-BY-PRICE OF DISTRIBUTED ENERGY RESOURCES AND FLEXIBLE DEMAND**

---

This paper has been submitted for publication in the IEEE Transactions on Smart Grid.

Copyright may be transferred without notice, after which this version may no longer be accessible.



# Information and Communications Systems for Control-by-Price of Distributed Energy Resources and Flexible Demand

Preben Nyeng, Jacob Østergaard, *Senior Member, IEEE*

**Abstract**—The control-by-price concept fits well with controlling small-scale generation, storage, and demand. In this paper, we investigate the required information and communications systems that are needed to realize the control-by-price concept for such units.

We first present a proposal for overall infrastructure and subsystem design, and secondly focus on the design and implementation of the end-user price-responsive controller, interfaces, and communications.

The design and its applicability on existing devices is verified through laboratory tests with two cases: Electric space heating thermostat control, and a small combined heat and power unit.

The results show that the price-responsive controller reduces the end-user's electricity cost, or increases his income respectively, by about 7 percent. At the same time, the price-responsive controller provides an interface for the transmission system operator to utilize distributed energy resources and flexible demand as a regulating resource.

Furthermore, the results illustrate and verify the applicability of the concept and the proposed infrastructure for controlling distributed energy resources and flexible demand.

**Index Terms**—control-by-price, distributed energy resources, micro-CHP, power system balancing, real-time market.

## I. INTRODUCTION

SINCE Schweppe et al.'s seminal paper on 'Homeostatic Utility Control' [1], the fundamental idea of letting small-scale generation, load and storage respond to the instantaneous electricity price has been investigated, and is still a subject for research and demonstration projects. With the increasing penetration of intermittent generation in the power system, the need for utilizing all available resources for power system balancing arises, and thus the need for a system that can control potentially millions of individual units on a time-scale in the order of a few minutes.

On the Olympic Peninsula, Washington, USA, a demonstration project has been conducted with a local 5-minute market comprising loads as well as small generators. The results are very promising and show a significant influence of the real-time price on consumers as well as small-scale producers of power [2].

This market concept uses an auction and bidding process prior to each 5-minute market interval to find the price. In our work we focus on a concept that is closer to the initial proposal in [1], in which an electricity price is determined by the system operator every 5 minutes based on the actual condition of the power system, and transmitted to the customers (which can either be net consumers or net producers). General feasibility analyses of the concept can be found in [3] and [4].

This 'control-by-price' concept is well suited to control many small units, due to its extreme transparency and simplicity. It implies that the price must be sent to the end-user in due time, and that a computer can receive the price and take appropriate control actions that maximize the end-user's profit.

In this paper, we investigate the required information and communications systems that are needed to realize the concept. In the following subsections, we propose an overall system architecture, and the associated communications systems and protocols. In section II, we describe the design and implementation of a price-responsive controller, and the laboratory setup we have used to verify the functionality of the controller and infrastructure. Finally we show laboratory results, obtained using the controller in connection with two different applications.

### A. Proposed System Architecture and Infrastructure

In Fig. 1 an overview of the proposed system architecture and infrastructure is shown. The price is calculated, based on input from the system operator about the present system conditions, and especially the need for balancing control actions. The price is then sent real-time to the end-users that have price-responsive controllers connected to DER units or controllable loads. For domestic applications this would typically be micro-CHP units, heat pumps, electric vehicle chargers or any other device that is able to reschedule, reduce, or increase generation or demand according to the electricity price.

The price-responsive controllers are central for the concept. These controllers receive the current price and take according control actions, and thereby create the link from system operator to balancing resource. In addition, the controllers must usually be able to receive settings and preferences from the end-user, and provide real-time and historical information

Manuscript received June 3, 2010.

P. Nyeng and J. Østergaard are with the Centre for Electric Technology, Technical University of Denmark (phone: +45 45 25 34 95; e-mail: pny@elektro.dtu.dk).

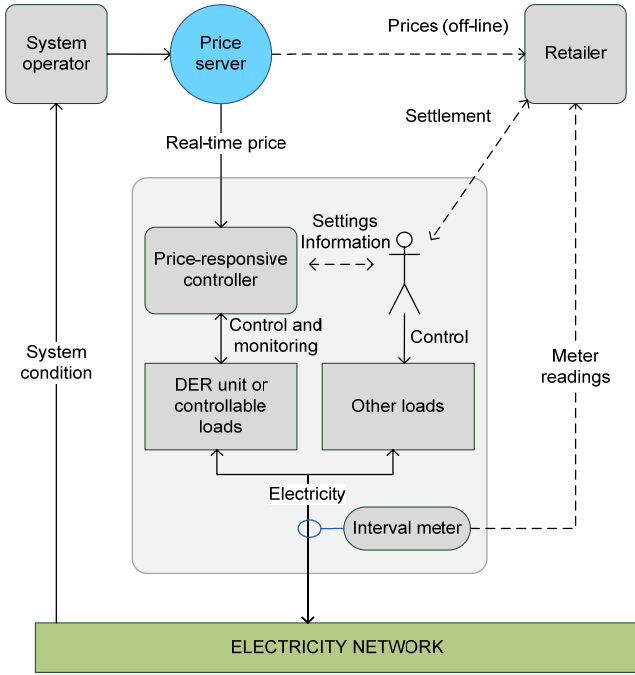

Fig. 1. System architecture and infrastructure overview. The dashed lines illustrate off-line processes.

about price and device operation to the user.

In section II we will consider the detailed design of a price-responsive controller, and in particular the algorithms used to decide what actions to take in connection with specific devices.

1) *Metering*: The response to a price update in terms of adapting the generation or demand, can be metered together with the other loads (and/or generation) in the building. In contrast to conventional balancing services, like the so-called regulating power in the Nordic market context, there is no need to monitor individual units and their response to assure that the response corresponds to what has been promised.

To be able to perform a subsequent settlement, the meter must be able to measure and store meter reading with 5 minute intervals. This implies a significant increase in the amount of information that must be transferred from the meter to the retailer, compared with the present situation where domestic meters usually supply one reading per year. An alternative solution is to integrate the product of price and electricity quantity locally in the meter, and transfer the resulting net value for settlement. However, this also limits the possibilities for adding taxes and grid tariffs in a flexible manner, and introduces problems, such as what the meter should do if the price is not available.

### B. Communications

The most critical communications link is the one between the price server, and the end-user site. The information is basically a unidirectional message, and broadcast media, e.g. radio signals could be used. However, with internet connections being readily available in many homes, utilizing this existing infrastructure seems more feasible. For easy adaptation, the protocols in use should be standardized, so that

manufacturers of price-responsive products would not have to implement separate protocols for each system they want their products to be integrated in. An overview of the proposed structure is shown in Fig. 2, and described in detail in the following sections.

1) *The Price Protocol*: In its most simple form, the concept only requires the prevailing price to be broadcast to all units. Doing so with internet media is fundamentally impossible, but the protocol used should imply the least possible overhead and processing requirements. This points towards a UDP-based protocol, inspired by e.g. time server requests, and name server lookups. In our case, we have implemented a very simple protocol, in which the client sends an empty UDP datagram to a server, which in turn replies with a single datagram containing the current price. This 'Price Protocol' copies the design of the Time Protocol [5], and requires the least possible overhead and processing, and can thus be implemented on virtually any platform, even low-cost microcontroller platforms with very limited performance.

2) *Complex Price Information*: The above protocol fulfils the absolute minimum requirement, but to improve the operation of individual units, more information is useful. The day-ahead price can for example be sent to the clients as well, and serve as a forecast of the real-time price to come. Furthermore, historical real-time prices could be published by the price server, to assist in the decision making process in the client. Evidently, such complex information calls for a standardized data structure, and e.g. the Common Information Model, specified in [6] and [7], could provide a standardized foundation for this. It fits well in the internet architecture, and is from the beginning based on XML formatting, that eases interoperability.

3) *DER Interface*: Finally, the interface between the price-responsive controller and DER devices needs attention.

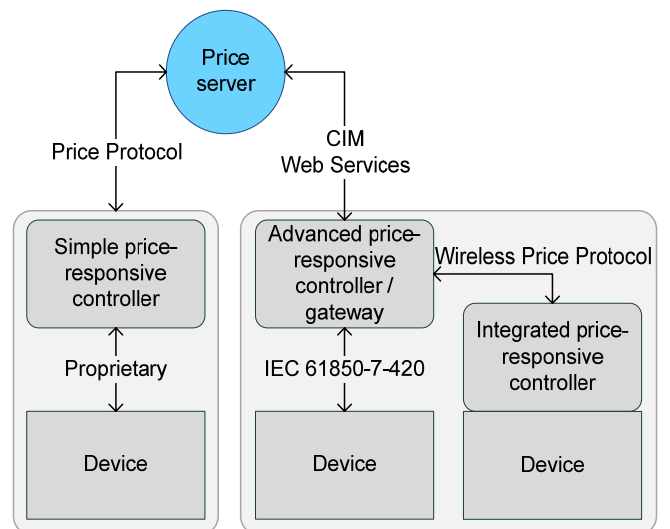

Fig. 2. Protocols and standards overview, and examples of their application. The structure allows for price-responsive controllers to act as gateways and forward price information to other controllers, by e.g. wireless media like ZigBee or Z-Wave.

This is most often using proprietary protocols, defined by the manufacturer of the DER device, but standardization would allow for a smoother adaptation of price-responsive controllers. The international standard IEC 61850-7-420 is an example of recent standardization work on DER communications [8]. This standard includes information models and communication protocol specifications for a range of DER devices. Its fundamental SCADA-like character aims at exposing status and control values to a remote party, which is exactly what the price-responsive controller needs to optimize operation according to real-time prices. However, its complex structure adds significant overhead to the communication, and the processing requirements connected with this does not fit well with the need for implementing low-cost microcontrollers in the DER units as well as in the price-responsive device. However, recent adaptation of the IEC 61850 principle to a lower communications complexity level, could indicate a future path in this direction [9].

## II. METHOD

Based on the proposed system architecture and infrastructure, we have designed and implemented a price-responsive controller for two different applications. In this section we first introduce the general price response control algorithm, and secondly, give a description of the two applications, their interfaces, laboratory setup, and specific application-dependent design of control algorithms that decide necessary control actions according to the real-time price.

### A. Price Signal

The real-time price is not published, so we have created a time series of real-time prices, based on hourly regulating power prices published by the Danish transmission system operator [10]. We have used 24 hours of data from 25 September 2009, for the price zone DK1. We use the regulating power price because it indicates the balancing cost for the hour, which is the marginal cost of the balancing service procured by the TSO, and thereby expresses the real-time price. Since it is only published by the hour, we interpolate the values to find 5-minute interval prices. In Fig. 3 the real-time price signal is shown together with the day-ahead price for the same day. We have chosen this particular day because the overall pattern follows that of a typical day, and at the same time exhibits a price spike, that occurs quite often in the Nordic regulating power market, and should have significant impact on the price-responsive control.

### B. Control Algorithm

The control algorithm used to implement the price response decision is fundamentally the same, whether it is used for the micro-CHP or the space heating thermostat. In both cases, it is mostly a matter of when they operate, rather than how much. Looking at the micro-CHP, for example, it must cover the heat demand of the building (assuming there is no alternative source of heat), and has no feedback from the building to assure that the temperature is right. It therefore has to maintain a predefined minimum temperature in the heating circuit,

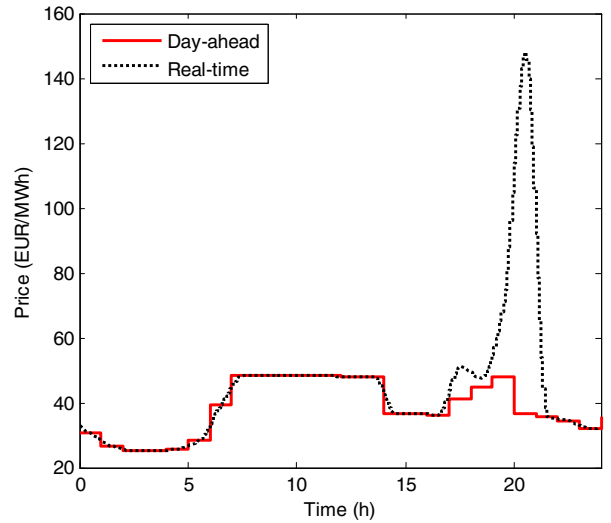

Fig. 3. Price signal and the day-ahead price. Data are from 25 September 2009, for the price zone DK1. The real-time price is created by interpolating regulating power prices.

which in turn means that it has to operate with a certain average duty cycle. However, the timing of the operation cycles can to a certain extent be rescheduled to periods with a high electricity price to maximize profit.

Similarly, the space heating thermostats can reduce demand by lowering the temperature, but the acceptable temperature deviation compared with the inside and outside temperature difference is often negligible. The largest profit potential is also here to reschedule demand, rather than try to reduce it, by utilizing the large heat capacity in the home.

1) *Relative Price*: With the wish for reacting on high or low prices, the problem with defining high and low emerges. If high and low relate to an absolute value i.e. monetary unit per energy quantity, it would impact the operation of the devices if the price for a long period was above or below the absolute thresholds.

Therefore, inspired by the use of the 24 hour sliding window mean price and standard deviation in [2], we introduce the dimensionless, relative price  $P_{rel}$  as the input price to the decision making process, defined by

$$P_{rel} \equiv \frac{P - P_{avg}}{P_{dev}}. \quad (1)$$

$P$  is the present price, and  $P_{avg}$  and  $P_{dev}$  are determined recursively for each time step  $\Delta t$  by

$$P_{avg,i} = P_{avg,i-1} + \frac{\Delta t}{\Delta t + \tau} \cdot (P - P_{avg,i-1}), \quad (2)$$

$$P_{var,i} = P_{var,i-1} + \frac{\Delta t}{\Delta t + \tau} \cdot \left( (P - P_{avg,i})^2 - P_{var,i-1} \right), \quad (3)$$

and

$$P_{dev,i} = \sqrt{P_{var,i}}. \quad (4)$$

$\tau$  is a time constant, that influences how long a price change affects the relative price, and thereby how fast the relative price adapts to price changes. Fig. 4 illustrates how



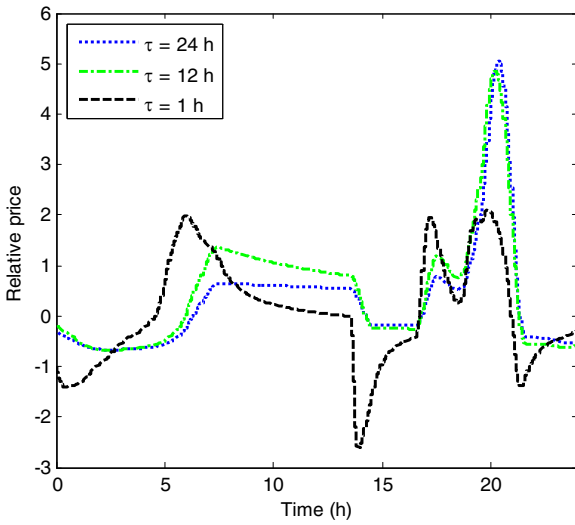

Fig. 4. Relative prices with different values of the time constant  $\tau$ . The relative price is calculated as a function of the absolute price from Fig. 3

different values of  $\tau$  impact the relative price with regards to magnitude and duration of price variations. A short time constant gives a lively curve with a rapidly increasing and decreasing price, that on the other hand faster descents towards a neutral price.

Compared with the sliding average method in [2], the relative price definition includes less statistical weight from the oldest samples, which means that there is no impact of historical values sliding out of the window. In addition it has the advantage with regards to implementation, that it can be calculated continuously without maintaining 24 sliding hours of data. However, upon controller reset the calculation still needs initialization values of  $P_{avg}$  and  $P_{var}$ , or the previously calculated values must be stored in nonvolatile memory. In each of our laboratory tests, we initialize  $P_{avg}$  and  $P_{var}$  as if the controller had been in operation for several days, each day with the same price time series as in the actual test.

### C. Micro Combined Heat and Power (micro-CHP)

The first design case is for the DACHS micro-CHP unit from Senertec. This unit comprises an engine that drives a generator, and can thereby generate electricity. The engine is cooled with water, that is circulated in the building for space heating. In this way more exergy is utilized from the fuel, and the process is in that sense more efficient than a traditional boiler. The unit is designed to fit in a normal to large residential home, in combination with a heat storage tank, or in smaller industrial buildings as supplemental heat. The key figures for the unit are listed in table I.

The device has an RS232 connection that is used for external monitoring, and in addition, it can be started or stopped by the use of an additional relay. The machine can generally either be started or stopped, and there is no option for throttling the engine. An overview of the micro-CHP subsystem is shown in Fig. 5.

1) *Heat Storage Emulation*: We do not actually have the heat storage tank in the laboratory, but use forced convection

TABLE I  
MICRO-CHP CHARACTERISTICS

Fuel	Natural gas, liquefied petroleum gas, fuel oil, or biodiesel (depends on variant)
Electric power	5.0 .. 5.5 kW (depends on variant)
Heating power	10.5 .. 12.5 kW (depends on variant)
Generator	2-pole induction generator, water-cooled
Engine	1-cylinder piston engine, direct generator drive
Start-up time, typical	90 seconds
Shut-down time	< 1 second
Minimum on-time	30 minutes
Interface, monitoring	RS 232, request-response protocol
Interface, control	Relay switch (no throttle)

caloriferes to dissipate the heat to the surroundings. To perform the test as realistically as possible with the available equipment, we have emulated the heat storage tank and the building heating circuit in the controller. To express the thermal energy stored in the tank, we use a single temperature and assume even temperature distribution in the tank. A real storage tank could have several temperature sensors and have temperature layers, however, the average temperature would still be a valid expression for the energy state.

The temperature in the heat storage  $T_{hs}$  is assumed to follow

$$\frac{dT_{hs}}{dt} = \frac{\dot{Q}_{CHP} - \dot{Q}_{demand}}{C_{hs}} \quad (5)$$

where  $\dot{Q}_{CHP}$  is the heat flow generated by the micro-CHP unit,  $\dot{Q}_{demand}$  is the heat flow to the building, and  $C_{hs}$  is the heat capacity, or thermal mass, of the storage tank. This assumption does not take the heat loss from the heat storage to the surroundings into account, because it is assumed to be negligible compared with the heat demand. We assume that the unit delivers its rated heat flow when it signals through the RS232 interface that it is running. In reality this is not the case due to the heat capacity of the unit itself, which means that it will not deliver the full heat flow in the first minutes after starting. However, we do not believe that this error significantly impacts the validity of the emulation.

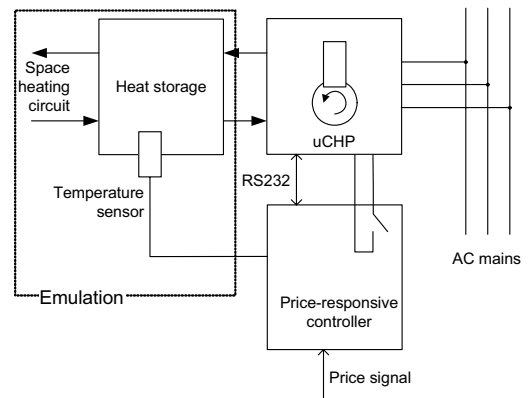

Fig. 5. Overview of micro-CHP subsystem. The price-responsive controller obtains status information through the RS232 connection, and control start and stop actions with the relay. In addition it monitors the temperature in the heat storage buffer, for system optimization.

The size of the tank is set to 750 liters, which is the size of the commercially available tank, that the manufacturer suggests for a typical domestic installation. The heat demand is assumed constant during the test, because the diurnal variation of outdoor temperature in winter is little, compared with the temperature difference between inside and outside. It is set to half the capacity of the micro-CHP unit, to emulate a winter day with an outdoor temperature around 0 °C. In spring or autumn the variation is more significant, and the demand generally lower. Table II summarizes the thermal parameters used for the micro-CHP test.

2) *Control Action Decision*: Based on the relative price, a decision must be made on what control actions to take, if any. The action can be to start, stop or remain in the current state, and if there were no constraints the decision could simply be to start when the relative price is above e.g. 1, and stop if it drops below e.g. 0.

However, the generation is constrained by the possibility to dissipate the heat that is generated along with the electricity. The heat storage temperature must be kept between certain limits, to meet the heat demanded by the building and avoid boiling. Because this constraint affects the opportunity to react on future attractive prices, the storage temperature should generally be kept low when the price is low, to maximize the potential profit to make when the price increases, and vice versa.

Finally, this particular micro-CHP unit has a minimum running time  $t_{on,min}$  equal to 30 minutes for each start. To honor this, the controller will only stop the unit when it has been running for at least 30 minutes, unless the maximum heat storage temperature is violated. Furthermore, it is only started when there is a certain margin to the maximum heat storage temperature.

The above considerations result in the decision diagram shown in Fig. 6. The parameter  $k_p$  is the relative price at which the controller will fully charge the heat storage, and is thus dimensionless. The value of  $k_p$  affects the responsiveness to price changes and must be chosen carefully to optimize profit.

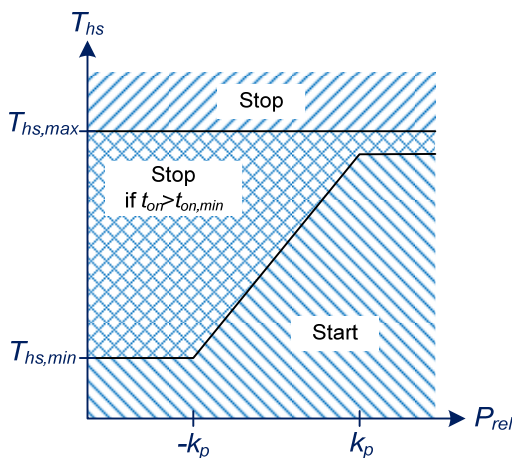

Fig. 6. Decision diagram for micro-CHP operation, depending on heat storage temperature,  $T_{hs}$ , and relative price  $P_{rel}$ , and observing the operation time since last start,  $t_{on}$ , in relation to the minimum operation time per start,  $t_{on,min}$ . The parameter  $k_p$  affects the responsiveness to price changes.

TABLE II  
MICRO-CHP THERMAL PARAMETERS

Storage tank capacity	750 L
Micro-CHP heat flow (when running)	10.5 kW
Heat demand (constant)	5.25 kW
Minimum heat storage temperature	50 °C
Maximum heat storage temperature	80 °C

It must be observed, that the value of the relative price time constant can affect the magnitude of the relative price (see Fig. 4), which effectively means that the time constant and  $k_p$  must be tuned as a pair.

#### D. Space Heating Thermostat

The other design case is for the Devireg 550 thermostat by DEVI. It is used in connection with electric space heating systems, and uses advanced filtering and adaptive control algorithms to compensate for disturbances and individual room characteristics. It contains an electromechanical relay that can switch the heater on or off, and thereby shares the lacking possibility for continuous power adjustment with the micro-CHP unit.

The thermostat has an interface for a proprietary network type, which can be interfaced to the surroundings by means of an RS232 adapter. This setup supports several thermostats on the same proprietary network, which can all be accessed using a single RS232 adapter. We use this interface to monitor and control the thermostat.

In the laboratory, we have used a model of a room, that roughly corresponds to a 1:10 scale of all length measures. It consists of an expanded polystyrene box, inside which the thermostat is mounted, together with the heater, a fluorescent light bulb of 11 watts. To create a temperature difference to the surroundings, the box resides inside a large refrigerator during the tests. The heat capacity in the box is increased with by adding mass inside it.

This model is not a good representation of a real room, as the ratios between thermal masses and heat transfer rates are affected by scaling it down. For example, the thermal mass scales 1 to 1000, whereas the heat conduction through the wall scales 1 to somewhere between 10 and 100. This severely impacts the time constants involved in the heating process, and consequently the dynamics of the price-responsive control, as will be shown in section III.

1) *Price-responsive Control*: Unlike the micro-CHP unit, the thermostat is not designed for direct external on-off control. The control parameter that is interfaced via the serial connection is the temperature setpoint, or rather an offset to the user's setpoint. This allows for an implementation close to the one in [2], except that we have chosen not to limit the offset, due to the use of the relative price that will tend to normalize towards zero offset, so extreme values will never persist. Consequently, the setpoint offset is set by

$$T_{offset} = -k_p \cdot P_{rel}. \quad (6)$$

In this case  $k_p$  is the temperature offset that will be set when the relative price is 1, and is thus expressed in degrees. This control method will not affect the average temperature, due to

the definition of the relative price, but may cause temporary temperature deviations. This in turn may affect the comfort experienced by the end-user, which means that the selection of  $k_p$  in this case is not only a matter of finding an economical optimum, like for the micro-CHP unit, but rather a trade-off between comfort and economy.

### III. RESULTS AND DISCUSSION

We have conducted tests on both the micro-CHP unit and the space heating system, and the results are summarized in table III. Examples of observations are shown in Fig. 7 and 8.

With the used price series, the price-responsive controller reduces the electricity cost with 7.6 % for the space heating setup, and increases the income with 7.3 % for the micro-CHP setup. For the latter, this happens without compromising the normal operation at all, whereas for the first, the consequence is a room temperature that varies several degrees over the course of a day. In numbers, the average is very close to the default operation with no price response, but the standard deviation of the temperature is 1.31 °C, compared with 0.65 °C without price response.

This is mainly due to the fact that the laboratory model of the room is not representative, as described in section II.D, which means that the temperature drops much faster than it

	Micro-CHP	Space heating
$k_p$	1	1 °C
Time constant $\tau$	12 h	8 h
Electricity generation/consumption	64.5 kWh	191 Wh
Average price earned/paid (Euro-cent per kWh)	4.78	4.11
Mean price (Euro-cent per kWh)	4.45	4.45
Additional income/saving	7.3 %	7.6%

would in a normal home. For this experiment a real home should be used, or a full-scale model in a climate chamber. However, the small model we have used still validates that the infrastructure, and the price-responsive controller and interface to the thermostat, works altogether.

With regards to the micro-CHP operation, it is observed that when the price is ramping from about 6 hours to 8 hours, the micro-CHP operates during the ramp, which means that the heat storage does not have much capacity left to let the micro-CHP operate during the long high-price period following the ramp. Apparently, this behavior is not optimal, but one must remember, that the controller only knows the price 5 minutes ahead, and has to optimize based on that. This is an example

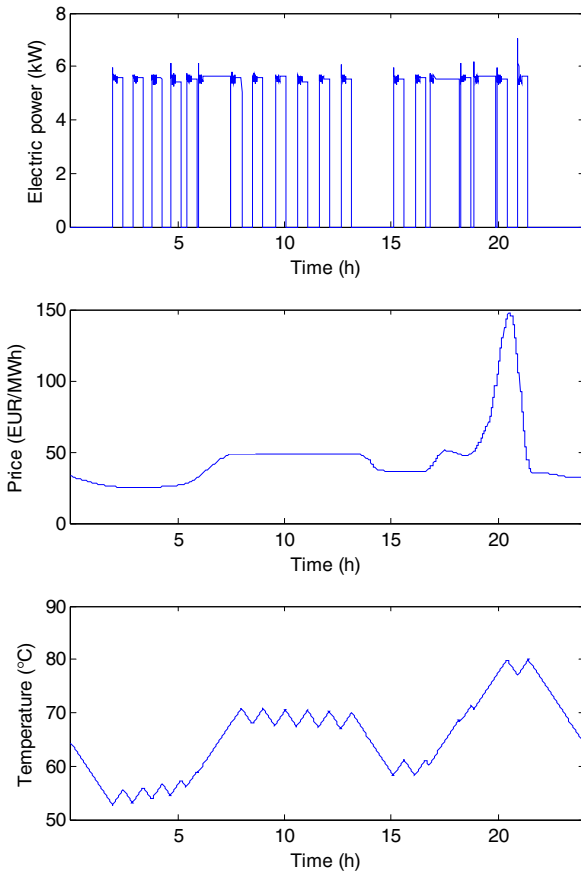

Fig. 7. Time series plots for micro-CHP operation.

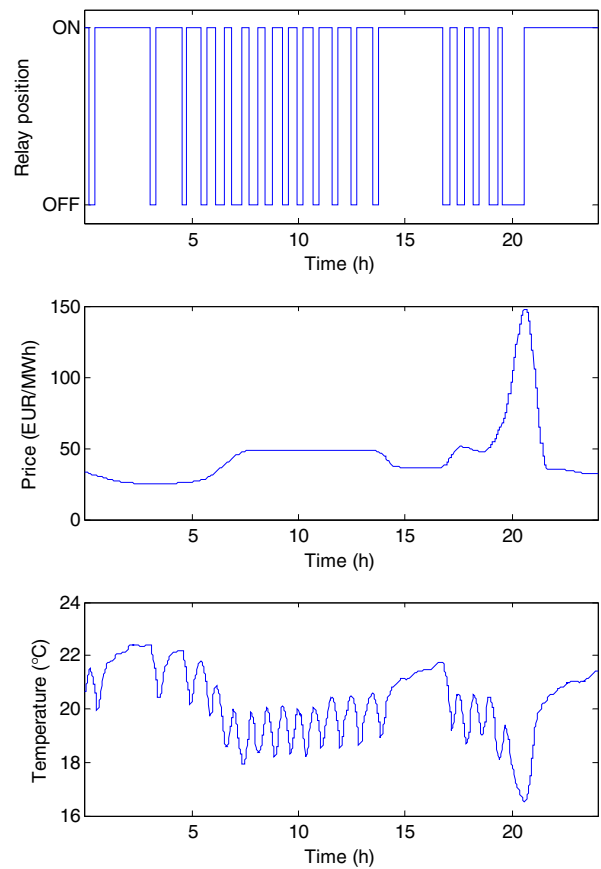

Fig. 8. Time series plots for space heating operation.

of how the day-ahead price schedule could have assisted in making a better decision, which is a topic we will address in future research.

This problem could possibly also have been reduced if the unit did not have to operate at full power. It may be more feasible to use a power setpoint rather than an energy (state-of-charge) setpoint. This would be possible if the machine could be throttled, or with applications that modulate the power with pulse width modulation. An example of this is the development in electric space heating systems, with heaters that operate in cycles as short as a few minutes, using pulse width modulation, or electric heat pumps with variable speed motor drives.

Looking from the system operator's point of view, this system has the potential to bring more capacity in the regulating power market, which in turn would reduce the cost for balancing. This cost is covered by those who cause imbalances, through the imbalance settlement. This is often intermittent generation, that with this system would have the imbalance penalties reduced. In the long run, this would make investment in renewable energy sources more attractive, and we believe that the control-by-price concept is an important step towards the ambitious targets in that direction.

With this work, we have conceptually outlined a complete infrastructure that can realize the concept, and in detail verified the operation of typical DER and flexible demand applications together with the price-responsive controller. The control principles that have been implemented and tested can easily be adapted to other applications.

#### REFERENCES

- [1] F.C. Schweppe et al., "Homeostatic Utility Control", *IEEE Transactions on Power Apparatus and Systems*, Vol.PAS-99, No.3, May-June 1980, pp.1151-1163.
- [2] D. Hammerstrom et al., "Pacific Northwest GridWise™ Testbed Demonstration Projects, Part I. Olympic Peninsula Project", National Technical Information Service, U.S. Department of Commerce, October 2007
- [3] F.L. Alvarado, "Is system control entirely by price feasible?", *Proceedings of 2003 HICSS*, Waikoloa, Hawaii, 2003.
- [4] F.L. Alvarado, "Controlling power systems with price signals", *Decision Support Systems* 40 (2005) 495–504.
- [5] Network Working Group, "RFC-868, Time Protocol", 1983.
- [6] IEC 61970-301, "Energy management system application program interface (EMS-API) - Part 301: Common information model (CIM) base", IEC, 2009.
- [7] IEC 61970-302, "Energy management system application program interface (EMS-API) - Part 302: Common information model (CIM) financial, energy scheduling and reservations", IEC, 2002.
- [8] IEC 61850-7-420, "Communication networks and systems for power utility automation – Part 7-420: Basic communication structure – Distributed energy resources logical nodes", IEC, 2009.
- [9] A. B. Pedersen, E. B. Hauksson, P. B. Andersen, B. Poulsen, C. Træholt, D. Gantenbein, "Facilitating a generic communication interface to distributed energy resources - Mapping IEC 61850 to RESTful services", *First IEEE International Conference on Smart Grid Communications (SmartGridComm)*, 2010, submitted.
- [10] Energinet.dk, Download of Market Data, [online], available: <http://www.energinet.dk/en/menu/Market/Download+of+Market+Data/Download+of+Market+Data.htm>

**Preben Nyeng** obtained the M.Sc. degree in industrial electrical engineering from the Technical University of Denmark (DTU), Lyngby, Denmark in 2000.

He was with Logos Design A/S from 2000 to 2006, developing embedded hardware and software systems, and related database and communications systems. Since 2006 he has been with the Centre for Electric Technology at DTU, as a PhD student in the field of intelligent energy systems, and related information and communication technology.

Mr. Nyeng is a member of CIGRE, the International Council On Large Electric Systems.

**Jacob Østergaard** (M'95–SM'09) obtained the M.Sc. degree in electrical engineering from the Technical University of Denmark (DTU), Lyngby, Denmark in 1995.

He was with Research Institute of Danish Electric Utilities for 10 years where he did research within power system transmission and distribution and was responsible for developing industrial-academic collaboration. Since 2005 he has been Professor and Head of Centre for Electric Technology, DTU. His research interests cover SmartGrids with focus on system integration of renewable energy and distributed energy resources, control architecture for future power system, and flexible demand.

Prof. Østergaard is serving in several professional organizations, boards and steering committees. He is head of the Danish experimental platform for electric power and energy, PowerLabDK, and he has been member of the EU SmartGrids advisory council. In 2009 he received the IBM Faculty Award.



# ***E*** **DESIGN AND IMPLEMENTATION OF FREQUENCY-RESPONSIVE THERMOSTAT CONTROL**

---

This paper has been accepted for publication on the 45th International Universities' Power Engineering Conference (UPEC) 2010



# Design and Implementation of Frequency-responsive Thermostat Control

Preben Nyeng  
Technical University of Denmark  
pny@elektro.dtu.dk

Jacob Østergaard  
Technical University of Denmark  
joe@elektro.dtu.dk

Mikael Tøgeby  
Ea Energy Analyses  
mt@eaea.dk

János Hethey  
Ea Energy Analyses  
jh@eaea.dk

**Abstract**—A power system’s AC frequency is a system-wide indicator of the immediate power balance in the system. This is used by selected generators to adjust the generation to level out imbalances continuously, as well as in the case of disturbances in the system. However, previous theoretical and empirical studies indicate that this service might as well be provided by demand-side control.

In this paper we investigate in detail how thermal energy storage capacity in thermostatically controlled electric loads can be utilised for frequency-responsive control. We use two specific applications as cases for our work: Refrigerators and electric space heating. These two cases clearly illustrate the vast diversity of critical parameters like heat capacity, switching cycles, and temperature tolerance. Based on these, we design appropriate control algorithms that bridge the gap, between on the one hand, the unique properties and needs of each application, and on the other hand the requirements of the system operator.

The control algorithms are implemented on a microcontroller unit that is interfaced with existing thermostats for each application. To validate the control algorithms and overall system design, a series of experiments are conducted, where the controller is subject to the actual grid frequency as well as designed frequency inputs, such as step inputs.

The results demonstrate that frequency-responsive thermostats can indeed provide a wide range of the frequency-responsive ancillary services requested by the system operators, with little negative impact on device operation and performance. The design analyses and the implementation experience also show that the retro-fitting approach to frequency response limits the ability for some devices to provide these services, compared with integrating the frequency response when designing the thermostat.

**Index Terms**—Ancillary services – Demand – Frequency-responsive – Reserve

## I. INTRODUCTION

The general concept of demand as frequency-controlled reserve (DFR) has been described in recent publications, e.g. [1]-[5]. These results indicate that there is a large potential for DFR applications, and that this way of providing frequency-controlled ancillary services to the system operator is indeed feasible.

In particular, the potential for refrigerators is identified as being interesting, due to small seasonal and daily variations of the load profile, which means that refrigerators can provide a predictable and reliable response. On the other hand, the amount of reserve per unit is comparably small, which in turn means that the number of units that respond to frequency changes must be very large to have an impact.

In contrast, electric space heating applications are usually several kilowatts, but have the obvious disadvantage that they

exhibit large seasonal and daily variations. This means that to utilize this resource, the immediately available reserve must either be monitored, or estimated based on the outdoor temperature.

In our work, we have focused on these two applications for the above reasons. In the following subsections, we focus on the requirements from the transmission system operator (TSO), in relation to the design of control algorithms and device implementations.

### A. System Requirements

Different power systems have different balancing schemes. In this section we focus on the two synchronous systems that Denmark takes part in, namely the Nordic system, and the continental European system (formerly Nordel and UCTE, respectively).

In the Nordic system there are two types of frequency-controlled reserves: The normal operation reserve and the disturbance reserve [6]. The difference is the frequency range in which the reserves are activated, and the required response time. Furthermore, the disturbance reserve only responds to negative frequency deviations, which means that it only provides up-regulation.

In the continental European system, there is only type of frequency-controlled reserve, the primary reserve [7]. It has a short response time, and is relieved by the load-frequency control, normally within minutes. The different types of frequency-controlled reserves in the two systems are summarized in Table I.

### B. Setpoint Design

The fundamental concept for frequency response by thermostats is illustrated in Fig. 1. The homogenous distribution of devices within the temperature hysteresis ideally assures a linear response to a frequency deviation, if the setpoint is adjusted proportionally to the frequency deviation, according to:

$$T_{set} = T_{set,0} + k(f - f_0) \quad (1)$$

for a heating application, and

$$T_{set} = T_{set,0} - k(f - f_0) \quad (2)$$

for a cooling application, where  $T_{set}$  and  $T_{set,0}$  are the actual and the preset setpoints, respectively,  $k$  is a (positive) coefficient, and  $f$  and  $f_0$  are the actual and the nominal system frequency, respectively.

It is observed from Fig. 1 that the full response to a frequency change is obtained when the setpoint is moved what corresponds to the temperature hysteresis. In other words, the control range is twice the hysteresis, and the value



TABLE I  
SUMMARY OF FREQUENCY-CONTROLLED RESERVES

Reserve	Frequency range	Response time
Normal operation reserve (Nordel)	+/- 100 mHz	150 s
Disturbance reserve (Nordel)	- 100/-500 mHz	5 s (50%) 30 s (100%)
Primary reserve (UCTE)	+/- 200 mHz	15 s (50%) 30 s (100%)

of  $k$  should be selected so that this range is not exceeded for the frequency range covered by the specific type of reserve in question.

For applications to be integrated in the continental European system, the design options are quite limited, since there is only one type of frequency-controlled reserve in this system. However, in the Nordic system there are two different types of reserve, and thus the question arises, if each application should be dedicated to a certain type of reserve, or if an attempt should be made to support both in the same device.

In Fig. 2 it is illustrated how the setpoint can be controlled based on the frequency for different implementations. There is a proposal for each of the Nordic reserve types, and a proposal for a combination. The combination is chosen to utilise the largest possible control range, which in this case

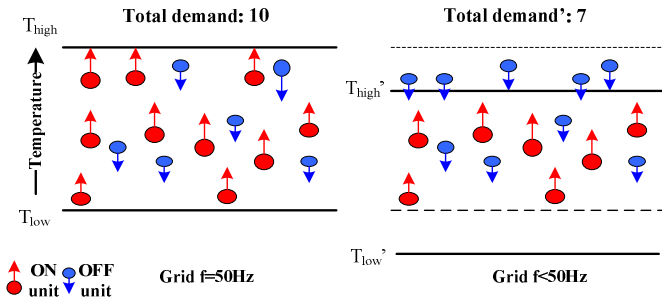

Fig. 1. Illustration of DFR concept with thermostats in a heating application. When the setpoint is moved as a response to a frequency drop, a proportional fraction of the devices switch off [1], [5].

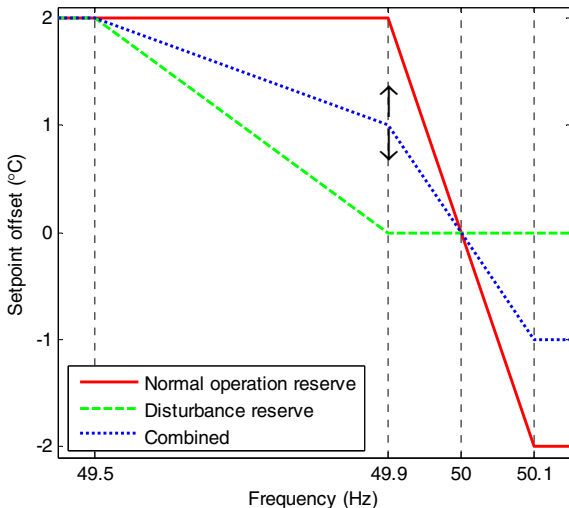

Fig. 2. Different setpoint design options, that meet the requirement for normal operation reserve or disturbance reserve, and a solution that contributes to both types of reserves. It is assumed that the temperature hysteresis is 2 °C.

means at most  $\pm 2$  °C, and at the same time assure that there is no temperature offset at nominal frequency. The distribution between normal and disturbance reserve contribution can be adjusted by changing the setpoint offset at 49.9 Hz up or down, as indicated in Fig. 2.

### C. Application Design

When designing the DFR application, there are other considerations to make than the setpoint vs. frequency design mentioned above. Most important is probably the device's natural switching pattern, and how the device operation is affected by setpoint changes. This has to be compared and aligned with the nature of the service provided by the application to the system.

Considering the normal operation reserve in the Nordic system, it is designed to level out the minor imbalances that occur during normal system operation. This implies small – but frequent – setpoint changes, and is therefore best suited for devices that have a natural cycle time of minutes rather than hours. Implementing this service in a device with a long natural cycle time will significantly shorten the cycle time, and may reduce the lifetime of the switch.

The lifetime of a typical electromechanical relay switching its rated current is about 100,000 cycles, equal to just a little more than 1 cycle per hour during an expected 10-year lifetime. This effectively rules out the use of high-current devices, such as electric heating systems, for this type of reserve unless it is taken into account when selecting the relay.

In comparison, the disturbance reserve is provided in case of unforeseen events such as a power plant failure. This implies quite rare control actions of short duration, and is therefore suitable for any device that can be interrupted for a short period (minutes). Detailed statistical material about the frequency and duration of under-frequency event can be found in [2].

Finally, the primary reserve in the continental European system is covering both types of reserve in a single service. This implies the same constraints on cycle time (or relay design) as the normal operation reserve in the Nordic system.

## II. METHOD

To validate the proposed design, we have implemented the algorithm in a microcontroller environment, and conducted laboratory tests using it. In this section the details about the implementation, and the laboratory setup and parameters are described.

We have implemented the frequency measurement and DFR logic in a separate microcontroller, and interfaced it with existing, commercially available thermostats. We have used two different thermostats, one for the refrigerator and another for the space heating application, and both were connected with the DFR controller through a serial data connection. A system overview is shown in Fig. 3.

The DFR controller used in the laboratory tests is based on an ARM7 microcontroller. It measures the grid voltage through a measurement transformer and analog signal conditioning. The frequency is determined by software using

the built-in A/D converter, using simple zero-crossing detection.

#### A. Refrigerator Setup

For the refrigerator experiments, a display refrigerator type Vestfrost M200 is used, equipped with an electronic thermostat Dixell XR30CX. This type of refrigerator is often found in stores where it is used to cool beverages. Compared with a typical domestic refrigerator it is larger, with less thermal insulation (partly due to the glass front), and a correspondingly more powerful compressor. Consequently it has higher energy consumption than typical domestic refrigerators, which in this case is an advantage as the reserve it can provide is similarly larger.

It can store about 240 standard-size 50 cl beverage bottles. During our tests, it has been filled with 120 such bottles of water, corresponding to 50% load, evenly distributed in the cooling compartment.

The temperature measured by the thermostat is the temperature of the air in the bottom of the cooling compartment. An additional temperature sensor has been used to measure the temperature in a single water bottle located in the middle of the cooling compartment. This is implemented separately from the DFR implementation with the purpose to monitor the cooling quality, and will not be present in a real-life implementation.

The temperature setpoint offset is controlled by a so-called Energy Saving (ES) function in the thermostat. This allows a setpoint offset to be sent to the thermostat, without modifying the preset setpoint, which means that the effective setpoint will always be relative to the preset setpoint. Consequently, the DFR logic is unaffected by setpoint changes on the refrigerator's thermostat.

A practical issue regarding the Energy Saving function is that it only accepts offset values with a 1 °C resolution. At first this seems difficult to combine with the requirement of a linear setpoint–frequency relation, but it has been circumvented by letting the DFR controller continuously monitor the temperature and change the ES offset just when the wanted temperature limit is reached. This effectively gives a resolution of the offset that equals that of the temperature measurement, i.e. 0.1 °C.

We have chosen to focus on the normal operation reserve for the refrigerator, mainly because it has a natural switching cycle time that makes it possible. With its default 2 °C

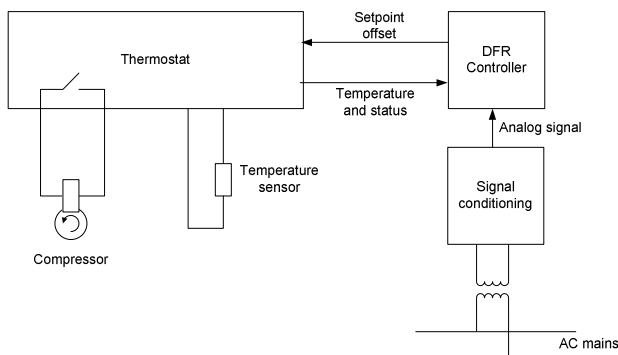

Fig. 3. Laboratory system overview in the case of refrigerator control. The space heating setup is identical except for the thermostat and compressor.

hysteresis, and a frequency range from 49.9 Hz to 50.1 Hz, the value of  $k$  is limited to 20 °C/Hz. An example of the setpoint–frequency relation is shown in Fig. 4 for different values of  $k$ .

#### B. Space Heating

The space heating thermostat is a Devireg 550 from DEVI. It is interfaced to the DFR controller by a serial connection, and like the refrigerator thermostat, this thermostat allows for an offset to the temperature setpoint to be sent to it, with the same advantages.

However, the natural switching cycle time for this thermostat can be several hours, which makes it unsuitable for normal operation reserve, and primary reserve. In addition, its built-in adaptive control algorithms are sensitive to frequent setpoint changes, which also prevents the use of this thermostat for these types of reserve.

It may still be used for disturbance reserve, though. Our desktop tests showed that the response time to a setpoint change could be several minutes, but after that, DEVI has provided a special version of the thermostat with a much shorter response time (around one second), which makes it possible to comply with the requirements. With regards to testing the DFR concept, rather than the implementation, we believe that the very long time constants found in these systems, compared with the short duration of under-frequency events, makes the outcome of such a test quite predictable, in terms of both the impact on the application and the power system. In fact, due to these characteristics, the fundamental idea of switching off the warmest units first in the case of an under-frequency event, is not very important, and it may be more feasible to switch off based on a simple frequency threshold.

For these reasons we have chosen to focus the following section on laboratory results on the refrigerator setup providing the normal operation reserve. All tests have been conducted with a temperature setpoint at 5 °C with the default 2 °C hysteresis. The ambient temperature has been the normal laboratory temperature, i.e. 22 °C to 24 °C.

The thermostat operates with a 3 minutes minimum off-

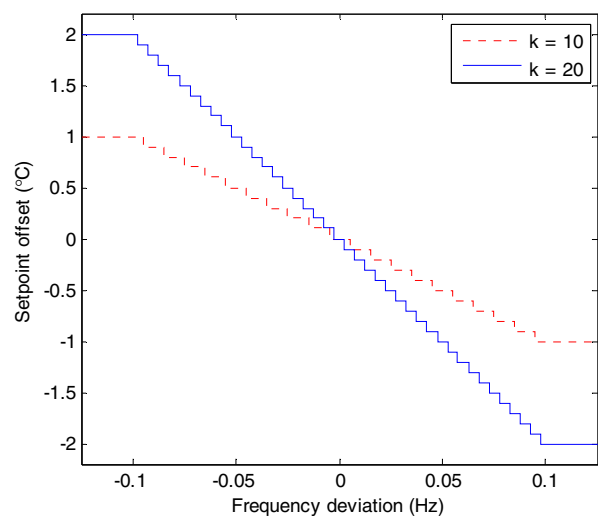

Fig. 4. Effective setpoint offset function with different values of  $k$  for the refrigerator controller.

time between compressor cycles, to allow the pressure in the cooling circuit to drop before switching the compressor on again. Furthermore, the thermostat will prevent the compressor from running for a 30 minute period every 6 hours, to let the cooler defrost.

Data is sampled by the DFR controller every 5 seconds. It records the frequency, air and water temperature, setpoint offset, and relay status.

### III. RESULTS

#### A. Single Unit Operation

For the following results, the refrigerator DFR setup has been subject to the prevailing system frequency, with  $k$  equal to 0 (i.e. no DFR control), 10, or 20.

Fig. 5 shows a time series with and without DFR operation ( $k=0$  and  $k=20$ ). The operation pattern is clearly affected by the DFR operation, leading to much more variation of the length of the switching cycles.

Table II summarizes the operational statistics observed. It is interesting that a larger  $k$  value seems to slightly increase the duty cycle, which in turn lowers the temperature of the air as well as of the water. This happens in spite of an average

TABLE II  
OPERATION STATISTICS

Temperature coefficient, $k$ (°C/Hz)	0	10	20
Average duty cycle	0.192	0.193	0.199
Average cycle time (s)	791	817	734
Average setpoint offset (°C)	0.0	0.0	0.0
Average air temperature (°C)	6.0	5.9	5.8
Average water temperature (°C)	6.4	6.0	5.9

setpoint offset of 0.0 °C, and is caused by the fact that the temperature adapts much faster to a setpoint lowering than to a setpoint raise. An adverse effect of this is that the energy consumption will increase along with the duty cycle, and to compensate for that, the setpoint could be slightly raised.

The cycle time seems to drop slightly with  $k=20$ , but it is not a significant impact and not likely to shorten the life-time of the thermostat's relay.

Other than the average temperature, the distribution of temperature is very relevant, because a larger temperature spreading will affect the way the user perceives the refrigerator's operation. Fig. 6 illustrates normalized histograms of the air temperature for different  $k$  values and it shows that there is no significant spreading of the temperature even for the larger  $k$  value. Same goes for the temperature measured in a water bottle, shown in Fig. 7. The spreading that occurs due to the DFR control is limited to less than a single degree, which is not likely to be noticed by the user.

#### B. Aggregate Response to System Frequency

In the laboratory we have used only a single refrigerator to test the impact on the unit by the DFR control. But from the power system's point of view, the aggregate response from a collection of units is more interesting. To analyze the aggregate response, using only a single unit, a statistical approach is used in the following.

The term Power Index is used to denote the probability of the compressor in the unit being in its ON-state, under a given set of conditions. It corresponds to the average duty cycle across a population of units under this set of conditions, and expresses the average power consumed per unit relative to the rated power of the compressor.

The expectation of a linear power response to a frequency change is based on the assumption of an even distribution of units between the upper and lower temperature limits, and an even distribution between ON and OFF units (Fig. 1). This implies a switching pattern with linearly increasing and decreasing temperatures, no temperature overshoot, and 50% duty cycle. Revisiting the normal operation time series (Fig. 5, top), it is worth observing that the switching pattern is far from the ideal picture.

This in turn affects the immediate impact of a temperature offset change, and combining this information with the frequency–temperature offset relation shown in Fig. 4, a curve describing the power index immediately following a frequency change can be derived (Fig. 8). These curves show what the power index will be, as a response to a sudden frequency deviation, following a period of steady-state operation at constant frequency.

Ideally these curves should be linear, but this is not the case. The curves are first of all unsymmetrical, due the low

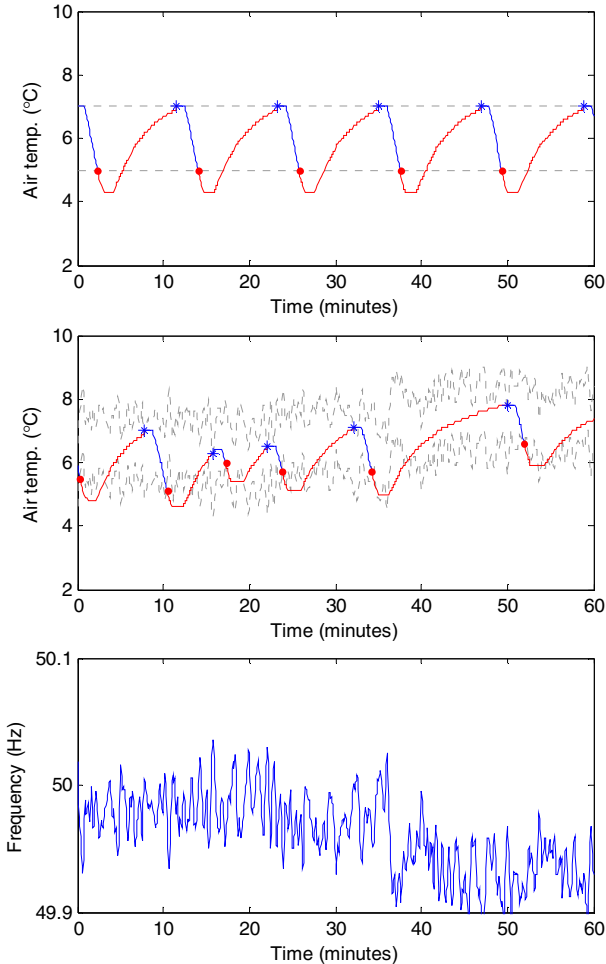

Fig. 5. Time series of measured temperature without DFR operation (top), with DFR operation (middle), and the measured frequency for the same time period (bottom). The dashed lines indicate temperature boundaries for switching, and the asterisks and dots indicate switching on and off respectively.

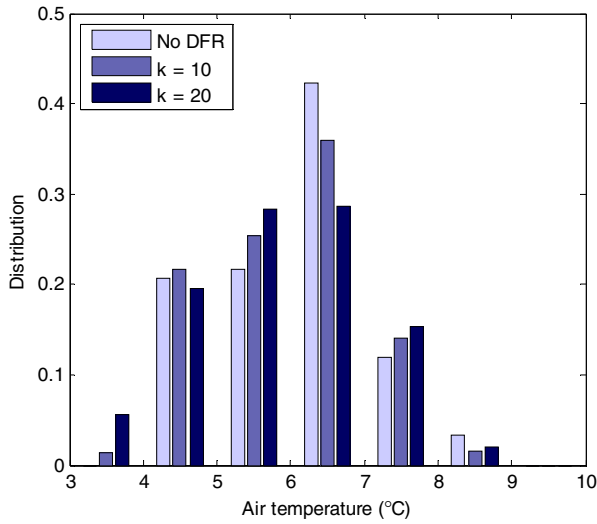

Fig. 6. Air temperature distribution

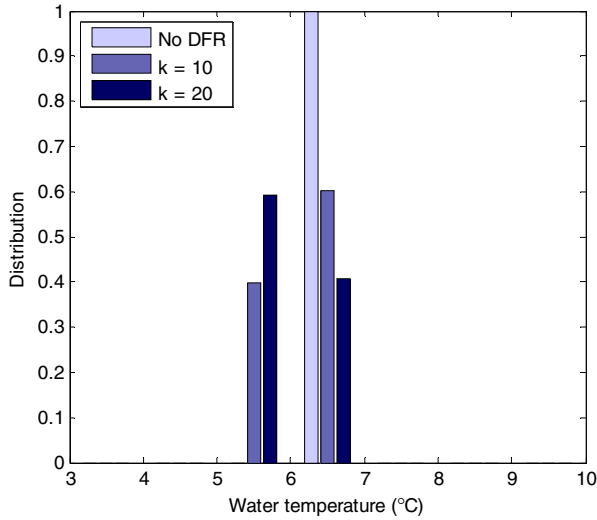

Fig. 7. Water temperature distribution

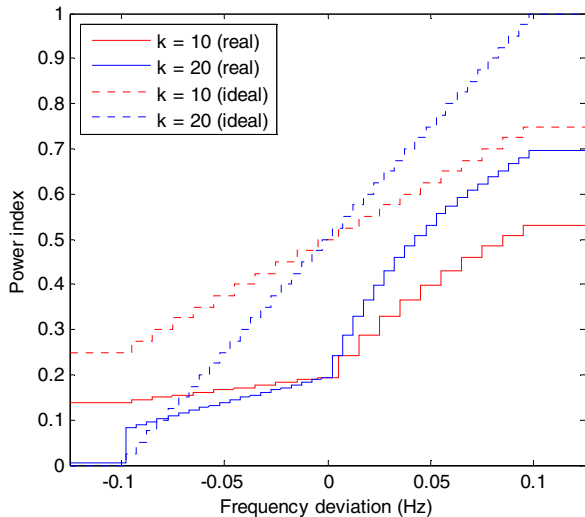

Fig. 8. Power index immediately following a frequency deviation from nominal system frequency. Curves denoted “real” are based on the real distribution of units in the temperature space, whereas those denoted “ideal” are based on an the ideal, homogenous distribution.

duty cycle (power index) that the refrigerator operates with, which means that the potential for consuming more power is significantly larger than for the opposite. Furthermore, even with  $k=20$  it does not reach 0 or 1 for  $\pm 0.1$  Hz, as the ideal one does. As for reaching a power index of 1, this is prevented partly by those units prevented from starting due to defrosting, or being within the minimum off-time, and partly due to many units already being well below the lower temperature limit, caused by the cooling overshoot. As for reaching a power index of 0, this is almost achieved, except for those few units that are recovering from a defrost cycle, and thus already more than  $2.0$  °C over the setpoint.

The sharp bend at  $-0.1$  Hz is caused by all those units that have switched on, but still remain at  $7.0$  °C (the flat pieces on the tops of the curve in Fig. 5, top figure). They will switch off after an offset of  $+2.0$  °C, but not for  $+1.9$  °C.

At first, the result in Fig. 8 seems discouraging, when compared with the requirement of a linear response to frequency deviations. However, it is important to consider the fact that these curves illustrate the power index immediately following a frequency step. During normal operation, the small and continuous frequency changes have a different impact. In Fig. 9, the samples are grouped by frequency, in a range of 25 mHz per group. For each group the power index is calculated as the number of samples where the compressor is on, divided by total number of samples in the group. This is a way of creating an overview of the aggregate response, by aggregating in time rather than across a population. This picture is more promising, and there seems to be an almost linear relation between the power index and the frequency, and as expected the slope is larger for larger  $k$  values.

### C. Aggregate Dynamic Response to a Step Input

So far we have examined the operation of a single unit, and statistically analyzed the aggregate DFR response. In this last section of results, we will analyze the dynamic response to a frequency step input. The data is still recorded with only a single unit, that has been subjected to a step input several times, starting at a random point in time. All the time series recorded in this way are overlaid in subsequent data

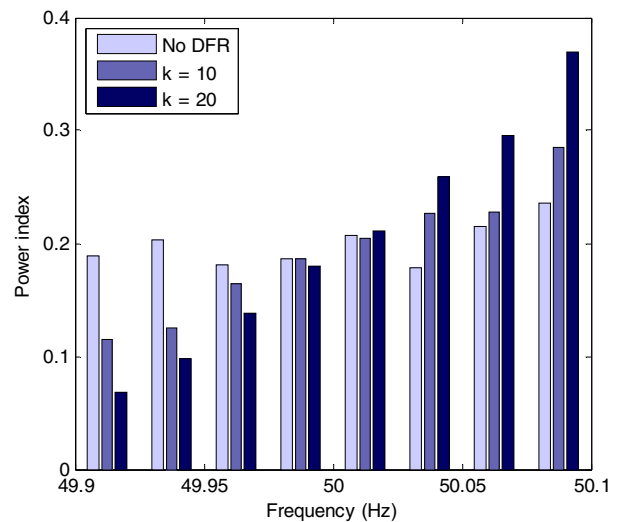

Fig. 9. Statistical representation of DFR response in 25 mHz frequency slots. Different values of  $k$  clearly impact the slope of the frequency response.

processing, and by doing that we can mimic the aggregate behaviour of a number of completely identical refrigerators.

In Fig. 10, the power index for the aggregation is shown in a time series plot. According to Fig. 8, the immediate response should be a power index drop from 0.20 to 0.14, if the units were evenly distributed within the time of an operation cycle. It appears that this is not a valid assumption prior to the step, and significant power index variation is seen. This is quite natural, considering that they are randomly (and not necessarily evenly) distributed, and with more units in operation, the random distribution would be more even.

What happens next is more interesting: Within a few minutes, all units switch off. This should be compared with the size of the step, which is  $1.0\text{ }^{\circ}\text{C}$  corresponding to 50% of the hysteresis. The temperature curves for each unit are plotted in Fig. 11 to give an understanding of this behaviour. It is caused by the fact that it takes much longer for the OFF units to reach the upper limit, than it does for the remaining ON units to reach the new lower limit. So this behaviour is much affected by the normal duty cycle for a unit, which must be taken into account when designing fast responding reserves, e.g. disturbance reserve.

#### IV. DISCUSSION

We have developed, implemented, and tested control algorithms for DFR applications on space heating and refrigerator systems.

As for the first, we find it best suited for disturbance reserve, due to its inherent limitations in its ability to provide normal operation reserve and primary reserve. Both the lifetime of the relay, and the built-in adaptive temperature control algorithms, prohibit the frequent setpoint changes necessary to provide these services. However, these are both problems that could be solved if the DFR concept is designed

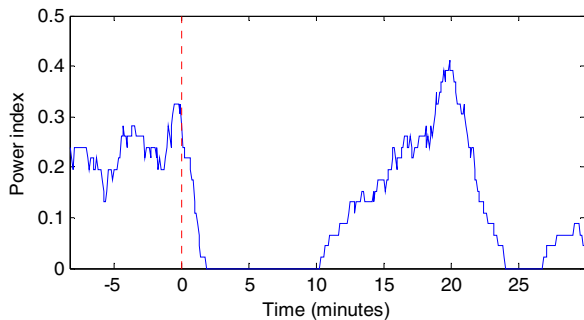

Fig. 10. Power index after step input of  $-50\text{ mHz}$  with  $k=20$ , i.e.  $1.0\text{ }^{\circ}\text{C}$  temperature offset step. The figure is based on 40 overlaid time series.

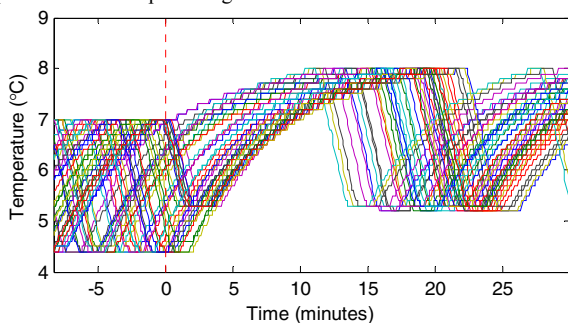

Fig. 11. Individual temperature curves after step input of  $-50\text{ mHz}$  with  $k=20$ , i.e.  $1.0\text{ }^{\circ}\text{C}$  temperature offset step.

into the thermostat from the beginning.

As for the refrigerator, our tests have demonstrated its ability to provide normal operation reserve, with as good as linear relation between frequency deviation and power consumption. The dynamic response to a step input have shown some issues that need to be addressed, if using this device for e.g. disturbance reserve. This could be addressed by more advanced control and signal processing, considering not only a simple frequency-setpoint offset relation, but taking into account the thermodynamics of the unit. Such advanced options may however be infeasible due to problems with verifying the DFR response for e.g. certification purposes, that could be used for an incentive scheme similar to what is already in effect for energy efficient appliances.

It should also be mentioned here, that some of the issues detected during the tests are related to the very low duty cycle that the unit operates with, which in a real-life situation would be higher due to a higher thermal load caused by the door being opened, and warm beverages being cooled down.

To summarize, we think that that our results support the perception of DFR as a feasible solution for frequency-controlled ancillary services, and we anticipate future studies in fully integrated solutions. In addition, the concept will be further investigated and proven during a one year field test on the Danish island Bornholm, to begin in the second half of 2010. The field test includes totally 200 DFR units, distributed on the mentioned space heating and refrigerator applications, as well as a number of custom installations, for example larger pumps.

#### ACKNOWLEDGEMENTS

This work has been funded under the EUDP programme by the Danish Energy Agency.

We would like to thank DEVI and Vestfrost for their collaboration, equipment, and creative input to the work. In addition we thank Dixell for willingly providing detailed technical information about the thermostat's serial connection and data register structure.

#### REFERENCES

- [1] Z. Xu, J. Østergaard, M. Togeby, C. Marcus-Møller, "Design and modelling of thermostatically controlled loads as frequency controlled reserve," *IEEE Power Engineering Society General Meeting*, 2007.
- [2] Z. Xu, M. Togeby, J. Østergaard, "Demand as Frequency Controlled Reserve – Final report of the PSO project", published by Ørsted-DTU, 2008.
- [3] J. A. Short, D. G. Infield, L. L. Freris, "Stabilization of Grid Frequency Through Dynamic Demand Control", *IEEE Transactions on power systems*, vol. 22, no. 3, august 2007
- [4] J. Hammerstrom et al, "Pacific Northwest GridWise™ Testbed Demonstration Projects. Part I. Olympic Peninsula Project and Part II. Grid Friendly™ Appliance Project", Pacific Northwest National Laboratory, 2007.
- [5] J. Short, S. Leach, "Using smart appliances to provide peak-load management and increase the efficiency of the electricity network", *International Energy Efficiency in Domestic Appliances and Lighting Conference*, 2006.
- [6] "AGREEMENT (Translation) regarding operation of the interconnected Nordic power system (System Operation Agreement)", 2008, available online at [www.entsoe.eu](http://www.entsoe.eu)
- [7] "UCTE Operation Handbook", available online at [www.entsoe.eu](http://www.entsoe.eu)

# ***F***

## **MODELING AND SIMULATION OF POWER SYSTEM BALANCING BY DISTRIBUTED ENERGY RESOURCES AND FLEXIBLE DEMAND**

---

This paper has been submitted for publication in the IEEE Transactions on Power Systems.

Copyright may be transferred without notice, after which this version may no longer be accessible.



# Modeling and Simulation of Power System Balancing by Distributed Energy Resources and Flexible Demand

Preben Nyeng, Casper F. Mieritz, Jacob Østergaard, *Senior Member, IEEE*

**Abstract**—In this paper we investigate the usage of distributed energy resources and flexible demand for power system balancing. The approach we use is detailed physical modeling of selected devices in connection with an inertia model of the Nordic power system, and the two control concepts: Frequency-controlled demand, and a 5-minute real-time market.

We model and simulate frequency-responsive demand represented by refrigerators, price-responsive demand represented by electric space heating, and finally price-responsive generation represented by micro-CHP units. The models are partly based on laboratory experience, partly on literature studies.

The results show the behavior of the individual technologies as well as the aggregate behavior of a power system balanced by a coherent set of resources. The results prove that the concepts are feasible, however problems related to the client-side price-responsive optimization algorithms are also revealed.

**Index Terms**—control-by-price, distributed energy resources, frequency-response, micro-CHP, power system balancing, real-time market.

## I. INTRODUCTION

POWER system balancing traditionally involves a combination of control actions, that altogether level out the continuously occurring power imbalances on a time scale from a few seconds to several hours. These control actions are orchestrated by the system operator through decentralized frequency monitoring and response on selected power plants, as well as centrally dispatched control signals. In all cases, however, does the actual energy balancing action originate from fairly large generation units. With the increasing penetration of intermittent generation in the power system, the need for utilizing not only these large units, but all available resources for power system balancing arises, and thus the need for a system that can control potentially millions of individual units on different time-scales.

The short-term frequency-controlled reserves can be constituted by loads that can defer the electricity demand, like heating and cooling applications that utilize their inherently built-in thermal mass to reschedule demand according to frequency. This concept was proposed in [1], and has more recently been investigated in several projects under different names (Grid-Friendly Appliances [2], Dynamic Demand

Control [3], and Demand as Frequency-Controlled Reserve [4], [5], and [6]). This concept fits into the already existing control scheme, and can directly support system operation along with the conventional resources.

With regards to the longer time scale from a few minutes to several hours, the existing control scheme is based on communication with a limited number of providers of balancing services, and would not be feasible in connection with a much larger number of smaller resources. To facilitate the integration of balancing services from small providers like individual, deferrable loads or micro-generation, a price-based control approach is proposed in [1], and further investigated in [7]-[10].

In this paper, we combine the above concepts in an aggregate model, to investigate how a future balancing scheme can perform, using a significant amount of demand-side and micro-generation balancing. Compared with the mentioned published work, we aim at presenting and analyzing a coherent balancing scheme, including the interaction between several subconcepts, and focus less on the individual subconcepts and implementation details. To simulate the aggregate behavior of such a system, thermodynamic models of participating devices have been developed. This includes the modeling of refrigerators for frequency-responsive control, and buildings used for price-responsive electric space heating applications.

## II. METHOD

### A. System Overview

The balancing scheme is simulated in a simplified power system model, with the purpose to consider the power and energy balance of the system. The model does not implement a grid, but is to be considered as a copper-plate (single-bus) system with one lumped generator and one lumped base load connected. In addition, a number of controllable distributed energy resources and flexible loads are connected to the system.

Based on the law of motion for the rotating mass that represents the lumped generators, the system frequency  $f$  is calculated recursively for each time step  $\Delta t$  in the simulation by

$$f_{i+1} = f_i + \frac{P_{a,i}}{f_i} \cdot \frac{f_0^2}{2 \cdot H \cdot S} \cdot \Delta t \quad (1)$$

where  $P_{a,i}$  is the immediate power imbalance (accelerating power),  $f_0$  is the nominal system frequency,  $H$  is the system's

Manuscript received June 28, 2010.

P. Nyeng, C. F. Mieritz, and J. Østergaard are with the Centre for Electric Technology, Technical University of Denmark (phone: +45 45 25 34 95; e-mail: pny@elektro.dtu.dk).



inertia constant, and  $S$  is the rated apparent power of the generator. The values of the constants have been chosen to simulate the Nordic power system, and are summarized in table I.

### 1) System control

Fig. 1 shows an overview of the control scheme. The control scheme incorporates frequency-responsive loads and price-responsive loads and generation. The first is modeled as refrigerators, but could in reality be any kind of short-term deferrable load. The price-responsive loads are space heating applications, and finally, the price-responsive generation is micro-CHP devices.

The total system imbalance  $P_a$  is the sum of the aggregate control response, the base load and generation, and possibly a disturbance. Using the power system model in (1), the system frequency is calculated, and fed back to the frequency-responsive loads and the price calculation.

In the Nordic system there are no control areas, so the calculation of system imbalance (similar to the area control error, ACE) is independent of inter-tie exchange. The real-time price signal is thus calculated as a direct function of the frequency deviation from nominal frequency. In the simulation, it is implemented as a conventional PID controller. The parameters for the controller were determined as part of the results analysis, and the control parameters are summarized in Table II.

In the following, the simulation models for the controllable loads and generation are described. Each model represents a single unit of the respective type. To assess the aggregate behavior, 1000 instances of each model are used in the simulation. Each of these instances can be scaled to represent any value of electricity demand or generation, in order to obtain a significant impact on the power system. In other words, the number of units is decoupled from the total rated power, and each instance of the model can therefore represent any number of actual physical units with identical parameters

TABLE I

SYSTEM PARAMETERS

Nominal system frequency	$f_0$	50 Hz
Rated apparent power	$S$	70,000 MVA
Inertia constant	$H$	4 s

TABLE II

CONTROL PARAMETERS

Total rated DFR load (refrigerators)	2,000 MW
Equivalent DFR reserve	$\pm 600$ MW
Total rated space heating load	1,000 MW
Total rated micro-CHP generation capacity	1,000 MW
Step disturbance	$\pm 300$ MW
Price controller P coefficient	12 EUR / Hz
Price controller I coefficient	0.028 EUR / (Hz·s)
Price controller D coefficient	1,200 EUR / (Hz/s)
Price update interval	5 minutes

and circumstances.

### B. Refrigerator model

The frequency-responsive loads in the model are constituted by refrigerators with DFR technology. Based on laboratory results with a specific refrigerator (see [6]), a thermal model of the refrigerator has been developed, as illustrated in Fig. 2.

The model consists of totally three thermal masses, between some of which heat can flow, according to Fig. 2. Each thermal mass is assumed to be uniformly heated, i.e. exhibit a homogeneously distributed temperature, and the heat flow between two thermal masses is assumed to depend on the temperature difference and a heat transfer coefficient only.

The primary mass  $C_1$  represents the contents of the refrigerator, and is the thermally heaviest mass that changes its temperature slowest. The secondary mass  $C_2$  represents the air in the refrigerator and the parts of the interior that is in good contact with the air and thus assumed to follow the air temperature. It is the temperature of  $C_2$ , that is measured and

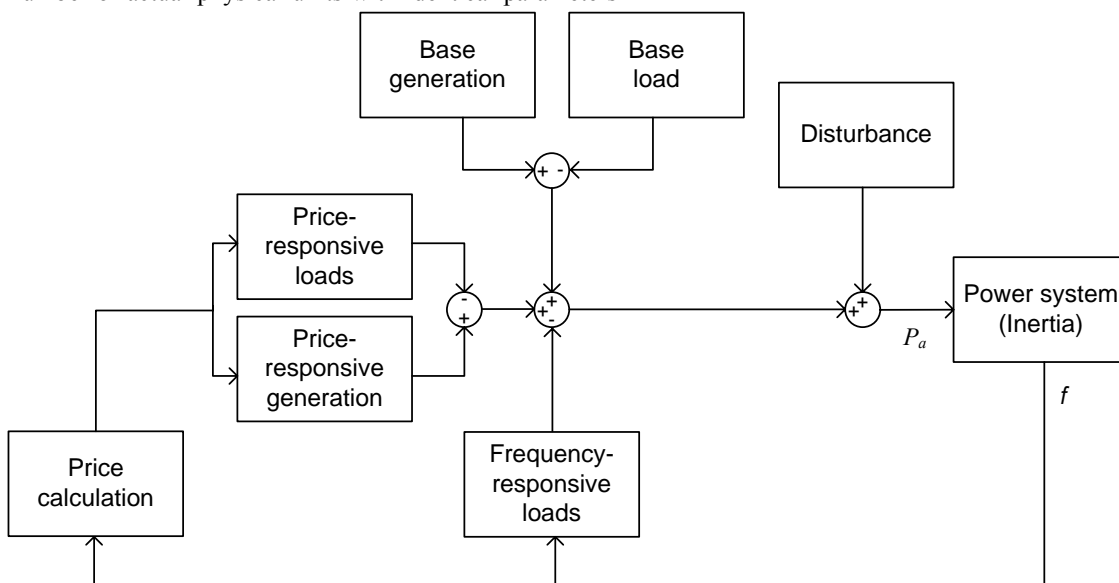

Fig. 1. System control scheme overview.

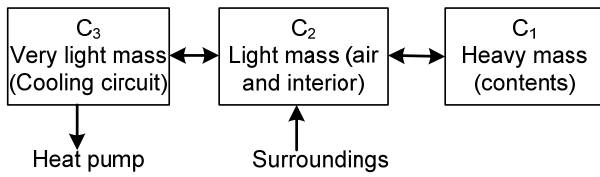

Fig. 2. Refrigerator thermal model.

controlled by the refrigerator's thermostat. Finally, the tertiary mass  $C_3$  represents the actual cooling circuit. It exhibits large temperature variations, but quickly levels out with the air temperature. The surroundings are modeled as a heat reservoir, i.e. with infinite heat capacity, and the ambient temperature is consequently constant.

For each time step  $\Delta t$ , each heat flow between the masses is calculated individually. Considering for example the heat flow from mass  $C_1$  to  $C_2$ :

$$Q_{1 \rightarrow 2, i+1} = U_{1 \leftrightarrow 2} \cdot (T_{1, i} - T_{2, i}) \cdot \Delta t \quad (2)$$

where  $U_{1 \leftrightarrow 2}$  is the heat transfer coefficient between masses  $C_1$  and  $C_2$ , and  $T_1$  and  $T_2$  are the temperatures of the two masses. Note that the  $U$  values are not area-specific.

Similar equations are used for the heat flows between  $C_2$  and  $C_3$ , and between  $C_2$  and the surroundings. The heat flow from  $C_3$  removed by the heat pump is considered constant when it is on, and otherwise zero.

When the heat flows for a time step are known, the temperatures can then be calculated. Considering for example  $T_1$ :

$$T_{1, i+1} = T_{1, i} + \frac{\sum Q_{i+1}}{C_1} \quad (3)$$

where  $\sum Q$  denotes the sum of all heat flows to or from the mass in question, and  $C_1$  is the heat capacity or thermal mass.

This model has been derived on the basis of laboratory tests, and the parameters have been selected so that the simulation model's behavior fits with the measured results. The parameters are listed in Table III.

The value of the thermal mass  $C_1$  is based on a loading of the refrigerator during the tests with half its rated capacity (which is mainly limited by the volume of the cooling compartment). During the simulations, each instance of the model is randomly initialized with a value of  $C_1$  that is spread out to represent a loading between 25 and 75% of the maximum capacity.

### 1) Refrigerator control

The refrigerators respond to system frequency by adjusting their setpoints according to frequency deviations from the

 TABLE III  
 REFRIGERATOR MODEL PARAMETERS

Thermal mass, 1	$C_1$	251 kJ/K $\pm$ 50%
Thermal mass, 2	$C_2$	13 kJ/K
Thermal mass, 3	$C_3$	1 kJ/K
Heat transfer coefficient, 1 $\leftrightarrow$ 2	$U_{1 \leftrightarrow 2}$	30 W/K
Heat transfer coefficient, 2 $\leftrightarrow$ 3	$U_{2 \leftrightarrow 3}$	12 W/K
Heat transfer coefficient, a $\leftrightarrow$ 2	$U_{a \leftrightarrow 2}$	5 W/K
Heat pump capacity (when ON)	$Q_{3 \rightarrow a}$	421 W

nominal frequency, such that

$$T_{set} = T_{set, 0} + k(f - f_0) \quad (4)$$

where  $k$  is a parameter, whose value is set to 20 °C/Hz, based on the laboratory experience. In addition, the model includes the limitation implied by the thermostat, that the compressor must have minimum 3 minutes off-time between cycles. Apart from that, the thermostat is modeled as simple temperature control with hysteresis, i.e. the compressor is switched on when the temperature is higher than the setpoint plus hysteresis (2 °C) and switched off again when the temperature is below the setpoint. The results in [6] indicate no significant delay in the refrigerator's response to a setpoint change, and no delay is therefore included in the model. However, the frequency measurement is assumed to be low-pass filtered with a time constant of 1 second, which in turn introduces a short delay between grid frequency changes and the corresponding setpoint change.

### C. Space heating / Building model

Following the same principles as the refrigerator model, a general thermal model of a house has been developed as illustrated in Fig. 3. The house is modeled as two individual thermal masses, one corresponding to the heat capacity of the air and furniture that is expected to follow the temperature of the air quickly, and another to the heat capacity of the construction.

The losses of energy to the surroundings are divided into a loss through ventilation and a transfer loss through the climate envelope corresponding to the construction. The different parameters of the model are described in the following sections, and summarized in Table IV.

#### 1) Thermal masses

The heat capacity of  $C_A$  consists of the air and furniture in the house. This is based on the assumption that the furniture is likely to follow the temperature of the room. The air's thermal mass is determined as

$$C_{A, air} = A \cdot h \cdot \rho \cdot c \quad (5)$$

where  $A$  and  $h$  denote the inside area and height of the building, and  $\rho$  and  $c$  are the density and specific heat capacity of air. Using 20 °C standard values for the latter, and an inside height of 2.5 m, the heat capacity of the air becomes

$$C_{A, air} = A \cdot 3 \frac{\text{kJ}}{\text{m}^2 \cdot \text{°C}} \quad (6)$$

It is difficult to estimate the thermal mass of the furniture. We use the same estimate as in [13], which is 1.25 cm of wood on the inside floor area, corresponding to

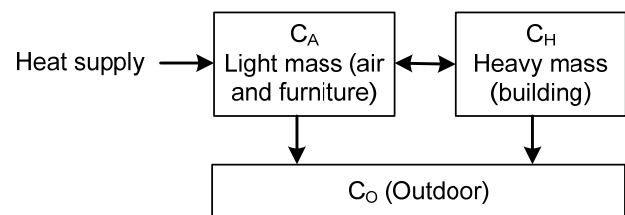

Fig. 3. House thermal model.

$$C_{A, \text{furniture}} = A \cdot 10 \frac{\text{kJ}}{\text{m}^2 \cdot ^\circ\text{C}}. \quad (7)$$

Consequently, the total thermal mass  $C_A$  becomes

$$C_A = A \cdot \left( 3 \frac{\text{kJ}}{\text{m}^2 \cdot ^\circ\text{C}} + 10 \frac{\text{kJ}}{\text{m}^2 \cdot ^\circ\text{C}} \right) = A \cdot 13 \frac{\text{kJ}}{\text{m}^2 \cdot ^\circ\text{C}} \quad (8)$$

The thermal mass of the building itself mainly depends on the construction type, which may be very individual. In [14], buildings are divided in typical categories, ranging from extra light to extra heavy, with thermal mass per square meter in the range as shown in Table IV. We have assumed a random distribution of buildings within this range.

## 2) Heat transfer coefficients

The heat transfer coefficient between  $C_A$  and  $C_H$  is assumed to depend on the inside surface area of the building,  $A_s$ . The heat transfer coefficient per surface area is based on standard values for surface resistance from [12].

The direct heat flow between  $C_A$  and the outside corresponds to the ventilation loss of a building and is given as

$$U_{A \leftrightarrow O} = A \cdot h \cdot \rho \cdot c \cdot n \quad (9)$$

where  $A$  and  $h$  denote the inside area and height of the building,  $\rho$  and  $c$  are the density and specific heat capacity of air, and  $n$  is the rate of air exchanged per time unit. To meet the minimum requirement of natural ventilation,  $n$  equals 0.5 per hour, or in other words, in theory the air is completely changed every other hour. Using the previous assumptions for  $h$ ,  $\rho$  and  $c$ , the heat transfer coefficient  $U_{AO}$  is then determined as

TABLE IV  
SPACE HEATING PARAMETERS

	Symbol	Value
Floor area	$A$	$133\text{m}^2 \pm 50\%$
Surface area	$A_s$	$A_s = 2 \cdot A + 4 \cdot \sqrt{A} \cdot h$
Thermal mass A	$C_A$	$13 \frac{\text{kJ}}{\text{m}^2 \cdot ^\circ\text{C}} \cdot A$
Thermal mass H	$C_H$	$\left( 360 \frac{\text{kJ}}{\text{m}^2 \cdot ^\circ\text{C}} \pm 60\% \right) \cdot A$
Heat transfer coefficient A↔H	$U_{A \leftrightarrow H}$	$7.69 \frac{\text{W}}{\text{m}^2 \cdot ^\circ\text{C}} \cdot A_s$
Heat transfer coefficient A↔O	$U_{A \leftrightarrow O}$	$0.42 \frac{\text{W}}{\text{m}^2 \cdot ^\circ\text{C}} \cdot A$
Heat transfer coefficient H↔O	$U_{H \leftrightarrow O}$	$\frac{A_s \cdot 7.69 \text{ m}^{-2} \cdot (A \cdot 1.07 \text{ m}^{-2} + 69.0) \text{ W}}{A_s \cdot 7.69 \text{ m}^{-2} - A \cdot 1.07 \text{ m}^{-2} - 69.0 \text{ } ^\circ\text{C}}$
Temperature, setpoint	$T_{set}$	$22 \text{ } ^\circ\text{C} \pm 1 \text{ } ^\circ\text{C}$
Temperature hysteresis	$T_A$	$1 \text{ } ^\circ\text{C}$
Temperature, outdoor	$T_A$	$7 \text{ } ^\circ\text{C}$
Controller price constant	$k_p$	$1 \text{ } ^\circ\text{C} \dots 2 \text{ } ^\circ\text{C}$
Relative price time constant	$\tau$	$24 \text{ h}$

$$U_{A \leftrightarrow O} = A \cdot 0.42 \frac{\text{W}}{\text{m}^2 \cdot ^\circ\text{C}}. \quad (10)$$

Finally, the heat transfer coefficient between the building and the surroundings is determined so that the total heat loss of the house matches the expected statistical values. The expression in Table IV is based on values for the annual heat consumption from [14], the yearly mean outdoor temperature, and the relationship between heat transfer coefficients, according to the series and parallel connections of thermal resistances:

$$U_{Total} = U_{A \leftrightarrow O} + \frac{U_{A \leftrightarrow H} \cdot U_{H \leftrightarrow O}}{U_{A \leftrightarrow H} + U_{H \leftrightarrow O}}. \quad (11)$$

## 3) Space Heating Control

The electric space heating is controlled by thermostats, that operate with conventional temperature hysteresis control, and switch the electric heater on or off. In accordance with [12], the heat source is sized to cover the heat losses of the house at  $-12 \text{ } ^\circ\text{C}$  outdoor temperature, based on the heat transfer coefficients of the individual instance.

To model inaccuracy in the temperature measurement, a small random error is added to the temperature when compared with the setpoint. This also accounts for events that can affect the individual temperatures, such as opening a window or a door. Apart from that, no randomness is introduced in the operation.

The thermostat's response to the real-time price is simulated according to the implementation in [15]. This includes the conversion from absolute prices (EUR/MWh) to dimensionless, relative prices, defined by

$$P_{rel} = \frac{P - P_{avg}}{P_{dev}}. \quad (12)$$

$P$  is the present price, and  $P_{avg}$  and  $P_{dev}$  are determined recursively for each time step  $\Delta t$  by

$$P_{avg,i} = P_{avg,i-1} + \frac{\Delta t}{\Delta t + \tau} \cdot (P - P_{avg,i-1}), \quad (13)$$

$$P_{var,i} = P_{var,i-1} + \frac{\Delta t}{\Delta t + \tau} \cdot \left( (P - P_{avg,i})^2 - P_{var,i-1} \right), \quad (14)$$

and

$$P_{dev,i} = \sqrt{P_{var,i}}. \quad (15)$$

$\tau$  is a time constant. The thermostats react on the relative price by adding a temperature offset  $T_{offset}$  to its temperature setpoint, according to

$$T_{offset} = -k_p \cdot P_{rel}. \quad (16)$$

The price constant  $k_p$  governs the responsiveness to price variations. Selecting this is a trade-off of comfort and economy, and it is therefore reasonable to assume that different end-users will prefer different values. Consequently, each instance of the electric space heating model is controlled with a value that is initially randomly selected in a realistic range that will give the end-users maximum temperature deviations in the order of a few degrees Celsius. The control parameters are included in Table IV.

D. Micro-CHP model

The micro-CHP model used in the simulations is based on the micro-CHP device and heat storage described in [15]. To a certain extent, the use of a heat storage tank decouples the generation unit operation from the heat demand of the building, or at least from the immediate demand variations. The thermal mass of the building is therefore not considered in this model, and the heat demand is considered constant.

The generation device itself is modeled as a generation unit with a short startup-delay. After the start-up delay, it ramps immediately to the rated power, which is maintained constant until stopped. The ratio between heat and electricity generation is constant.

1) Micro-CHP control

The micro-CHP devices are price-responsive according to the implementation described in [15]. This control method considers the history of the price, and uses the flexibility provided by a heat storage tank to react on relatively high or low prices. Essentially it sets the desired temperature – or state-of-charge – of the heat storage as a linear function of the relative price, as defined in (12). In addition, the price-responsive controller will to the largest possible extent respect the recommended minimum operation time.

The parameters for the device and the controller are listed in Table V.

TABLE V  
MICRO-CHP CHARACTERISTICS

Electric power	5.5 kW
Heating power	12.5 kW
Building heat demand	6 kW ± 50%
Start-up delay	90 seconds
Shut-down time	Immediately
Minimum on-time	30 minutes
Controller price constant $k_p$	1
Controller relative price time constant $\tau$	12 h

III. RESULTS

A. DFR simulation

To evaluate the impact of the DFR technology, the aggregation of many refrigerators is exposed to a frequency step. In these results, the power system model is not included. The result of positive and negative steps are shown in Fig. 4. The step increases the tendency of synchronism of the devices, that leads to oscillations of the demand, that can persist for several hours. This is in line with the step response observed in the laboratory tests in [6].

However, even though this step response is technically not complying with the requirements from the transmission system operator, the DFR loads may still fulfill the TSO's needs for frequency-controlled reserve in the power system. In the following results, the power system model is included in the loop, and the step input is now a power imbalance step disturbance of 300 MW.

The total rated power of all the refrigerators is set to 2,000 MW, which approximately corresponds to the requirement of ±600 MW frequency-controlled normal operation reserve in the Nordic system. The results are shown for a positive imbalance step in Fig. 5, i.e. a sudden load reduction, and symmetrical results are obtained for the negative imbalance.

Compared with Fig. 4, the oscillations now very quickly settle after the step, and the refrigerators rapidly adjust their demand to the new balance situation. However, it is also observed that the frequency is not kept constant after the step, due the heat capacity being depleted. This calls for

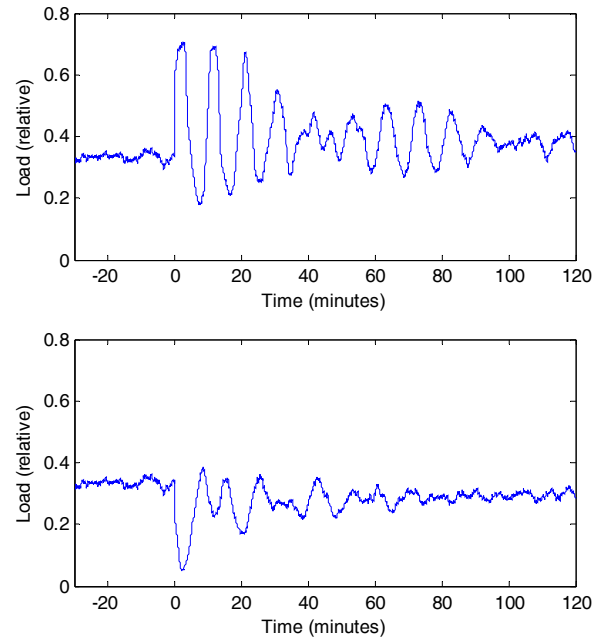

Fig. 4. Aggregate DFR response to step input of 50 mHz. The top figure shows a positive step, and the bottom figure a negative step.

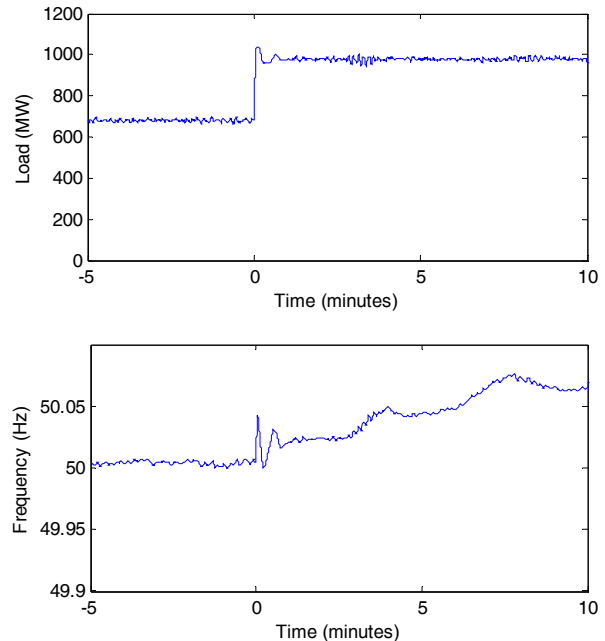

Fig. 5. Aggregate DFR response to power imbalance step of 300 MW with inertia power system model included. The top figure shows the aggregate refrigerator load, and the bottom figure the system frequency.

supplemental control actions within 10-15 minutes, which is in line with what is normally expected in power system operation.

### B. Price response

In this section the open-loop response to price changes is investigated. There is price-responsive loads as well as generation in the model, and in the following we investigate the behavior of each of these when subjected to price steps.

The price-responsive control algorithm that is used in the models has the property that it adapts to the fluctuations in the price input. It means that to evaluate the step input behavior, the algorithm must be initialized with reasonable values, since a constant price prior to the step will not give a reasonable initialization. For these results, we initialized the algorithm with a mean value of 50 EUR/MWh, and standard deviation 10 EUR/MWh. The step input is 1 EUR/MWh, either up or down, which together with the chosen initialization, results in a  $\pm 0.1$  step input in the relative price.

#### 1) Micro-CHP response

The results for the micro-CHP units are shown in Fig. 6. The response to the positive price step is very sudden, in both ramping up and down. This is caused by the way the control algorithm sets an energy setpoint rather than a power setpoint. This means that when the price is changed, an immediate reaction is seen in the generation, but when the new energy storage state-of-charge value is reached, the units go back to normal operation. This could cause problems with balancing the system, if there are many of the same type of device in the system, with the same control algorithm.

For the negative step this behavior is limited by the minimum operation time of the unit, which means that only some units are eligible for turning off.

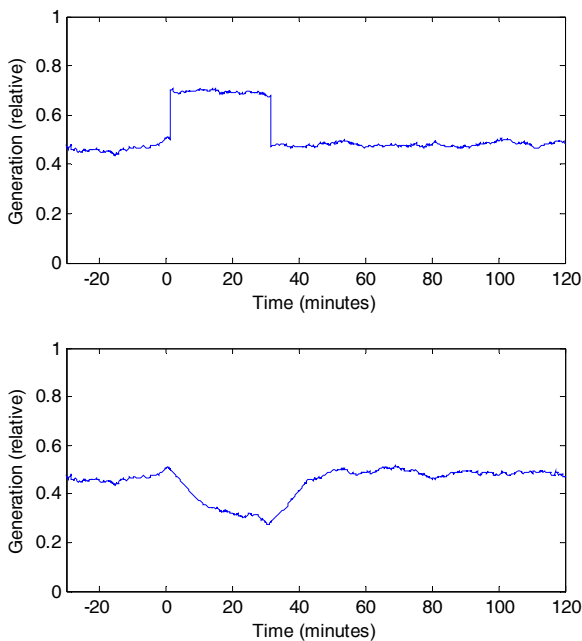

Fig. 6. Aggregate micro-CHP response to 1 EUR/MWh price step. The top figure shows the response to a positive step, and the lower figure the response to a negative step.

#### 2) Electric space heating response

The results for the electric space heating are shown in Fig. 7. It is observed that the results are symmetrical with regards to the direction of the price step. It is also observed that there is a short transition period, after which the demand slowly approaches a new steady-state value. Simulations have shown, that even after 10-12 hours the impact of the price step is still noticeable. This can be compared with the response of the micro-CHP unit, and it seen that the space heating application has a significantly longer lasting, but likewise smaller, response.

### C. Aggregate closed-loop response

In this section the closed-loop behavior of the entire control loop is investigated, as depicted in Fig. 1. Each instance of the space heating and micro-CHP models is scaled to sum up to a total of 1,000 MW of each type. The parameters of the PID controller that generates the prices were selected to obtain reasonable system behavior in terms of stability and settling time after a step disturbance. The parameters for the simulation are summarized in Table II, and the simulation results are exemplified in Fig. 8 for a negative disturbance case, i.e. a sudden loss of generation or a load step.

It can be observed that the DFR loads quickly absorb the disturbance, and that the price shortly thereafter starts increasing. The aggressive ramping of the price-responsive units is reflected in frequency glitches after every 5 minutes price update. This adverse effect of the considered price control algorithm also prevents tuning the controller to completely remove the steady-state frequency error that remains, as increasing the  $I$  coefficient in the controller results in instability.

It is also observed that the micro-CHP generally responds

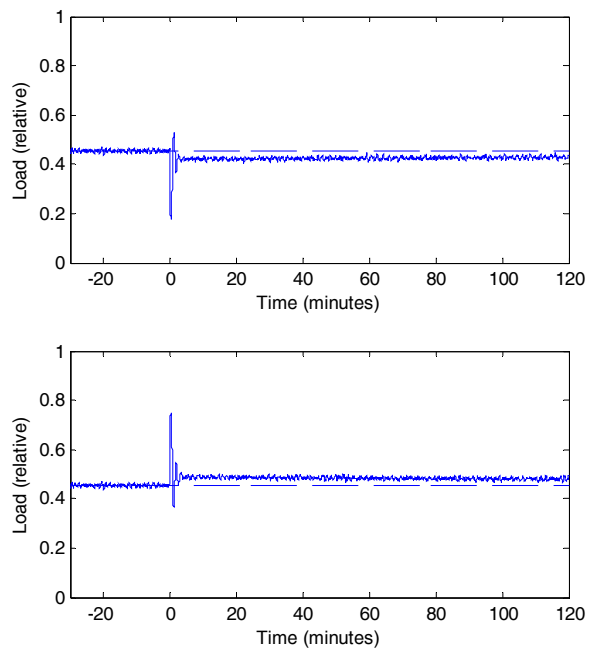

Fig. 7. Aggregate electric space heating response to 1 EUR/MWh price step. The top figure shows the response to a positive step, and the lower figure the response to a negative step.

much faster than the space heating, apart from the initial response, whereas the space heating sustains the response much longer. Even after two hours, the space heating maintains the trend to reduce the demand. This is due to the fact that the thermal storage in the building can only be discharged or recharged very slowly if the room temperature must be kept within acceptable, comfortable limits. This on the other hand illustrates that space heating can be used for balancing on a longer time scale than just a few hours.

The balance between micro-CHP and space heating response to price changes is of course affected by the installed or rated capacity of both, and the selected price control parameters in each device. We have chosen to illustrate a case

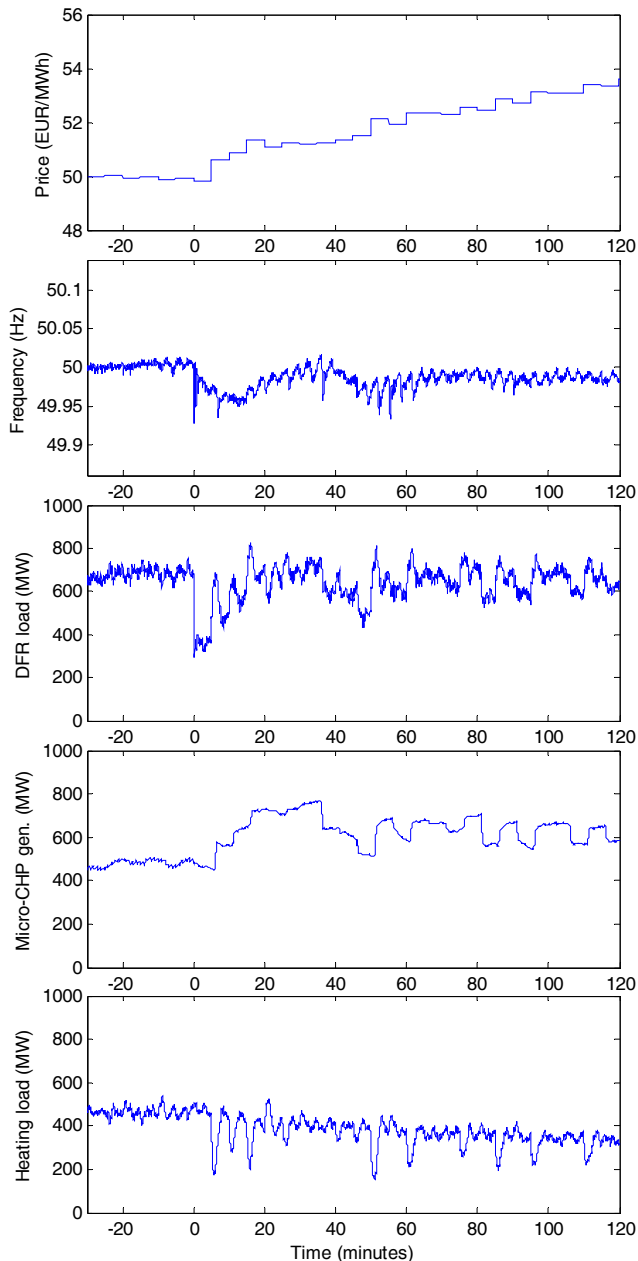

Fig. 8. Aggregate response to 300 MW negative step imbalance, i.e. a sudden loss of generation. Includes all parts of the simulation model.

with equal amounts of both types, but in future large-scale roll-outs only time will show which technologies will prevail.

#### IV. DISCUSSION AND CONCLUSION

The results in this paper demonstrate that the concepts of frequency-controlled demand, and control-by-price of demand and small-scale generation, can indeed contribute to power system balancing, in the time scale from seconds to many hours. This has been simulated on realistically modeled devices, and with control methods that have already been implemented and tested in the laboratory.

With regards to the refrigerator and micro-CHP devices used in the simulations, these are both specific devices that we have in-depth laboratory experience with. Their behavior, and specifically the thermal model of the refrigerator, are thus well-established and verified. However, the validity of the thermal model of buildings may be discussed. We believe that our assumptions made on the basis of available data are reasonable, but of course a laboratory validation would further strengthen the credibility. Validating a thermal model of a building is however tedious and requires laboratory facilities beyond our reach, and we hope that future field tests will provide the necessary knowledge on this topic.

An adverse effect of both the DFR and the control-by-price concept is the tendency of many units to synchronize their switching pattern after a frequency or price change, respectively. This is extremely predominant for the micro-CHP units, but has also been observed for both the DFR refrigerators and the electric space heating. Adding even a little randomness in the operation results in a quick dissolving of this synchronized behavior, and we therefore believe that this phenomenon is unlikely to occur in real-life applications where each instance will be affected by randomly occurring events, like opening of the refrigerator door, or people or sunshine affecting the space heating demand.

When looking at the results of the aggregate closed-loop control the frequency seems to vary a lot, and the overall impression is generally far from that of conventional droop control and automatic generation control provided by power plants. There is no doubt that the control-by-price concept will stress the frequency-controlled reserves compared with conventional methods, however this underlines the need for DFR in the system, as this technology provides a much faster response, and is not severely affected by tear and wear from frequent control actions like e.g. hydro or thermal power plants.

The micro-CHP case also illustrates the necessity of well-designed price-control algorithms. The algorithm applied in this paper was initially designed from the point of view of the micro-CHP operation, and was focused on optimizing the profit for the owner of the device. However, the aggregate behavior illustrated in this paper clearly shows that this control algorithm is not optimal for reliable system operation. In our future work we will further investigate this problem, and look into the design of win-win algorithms, i.e. algorithms that can optimize profit for the end-user whilst providing a feasible aggregate response to price changes. It is important to

remember in this connection, that it is assumed that the system operator has no influence on the control algorithm used by each client. This means that the clients will optimize for profit only, and it may be necessary to look into grid code requirements to mitigate adverse emerging behavior. If for example a minimum off-cycle time was enforced on the unit, similar to its own minimum on-time, the tendency for many units to start at the same time would be reduced.

The problem might also be mitigated by including more different resources in the setup. Electric vehicle chargers can for example provide the same balancing service, and further have the option to not only switch on or off, like the devices modeled in this paper, but instead control the charging current gradually. In principle, at least, this gives the opportunity to provide a smooth response to price changes. With a large penetration of such loads, the more sudden response by other types of resources may be leveled out, in particular if the chargers also respond to frequency changes.

In addition to the above topics, future work should also aim at demonstrating these concepts in reality, as they both depend on the end-user's acceptance. We are at present involved in the preparations of the roll-out of more than 150 frequency-responsive loads on the Danish island Bornholm, to gain experience with the DFR application. With regards to the control-by-price concept, there is also a need for demonstrations and field tests, and we are currently participating in a joint research project on this topic, that will include a field test, also in the premises of Bornholm.

To summarize, we believe that we have provided some evidence of feasibility of the emerging technologies, DFR and control-by-price. The DFR technology seems to be a mature and sound concept, which is also supported by previous studies. Regarding the control-by-price concept there are still some challenges to address, in particular with respect to client-side control algorithm design. With future research, field test and demonstration projects we will aim at resolving at least some of these issues.

#### REFERENCES

- [1] F.C. Schweppe et al., "Homeostatic Utility Control", *IEEE Transactions on Power Apparatus and Systems*, Vol.PAS-99, No.3, May-June 1980, pp.1151-1163.
- [2] D. J. Hammerstrom et al., "Pacific Northwest GridWise™ Testbed Demonstration Projects, Part II. Grid Friendly™ Appliance Project", National Technical Information Service, U.S. Department of Commerce, October 2007
- [3] J. A. Short, D. G. Infield, L. L. Freris, "Stabilization of Grid Frequency Through Dynamic Demand Control", *IEEE Transactions on power systems*, vol. 22, no. 3, august 2007
- [4] Z. Xu, J. Østergaard, M. Togeby, C. Marcus-Møller, "Design and modelling of thermostatically controlled loads as frequency controlled reserve," IEEE Power Engineering Society General Meeting, 2007.
- [5] Z. Xu, M. Togeby, J. Østergaard, "Demand as Frequency Controlled Reserve – Final report of the PSO project", published by Ørsted-DTU, 2008.
- [6] P. Nyeng, J. Østergaard, M. Togeby, J. Hethey, "Design and Implementation of Frequency-Responsive Thermostat Control", in *Proc. 45th International Universities' Power Engineering Conference 2010*, to be published.
- [7] F.L. Alvarado, "Is system control entirely by price feasible?", *Proceedings of 2003 HICSS*, Waikoloa, Hawaii, 2003.
- [8] F.L. Alvarado, "Controlling power systems with price signals", *Decision Support Systems 40* (2005) 495–504.
- [9] D. J. Hammerstrom et al., "Pacific Northwest GridWise™ Testbed Demonstration Projects, Part I. Olympic Peninsula Project", National Technical Information Service, U.S. Department of Commerce, October 2007
- [10] D. Feng, P. Nyeng, J. Østergaard, J. Zhong, "New real-time market facilitating demand-side resources for system balancing", *IEEE Transaction on Industrial Electronics, Special Section on Methods and Systems for Smart Grids Optimization*, submitted for publication.
- [11] E. Kazanavicius, A. Mikuckas, I. Mikuckiene, J. Ceponis, "The Heat Balance Model of Residential House", Kaunas, 1392-124X, 2006
- [12] Danish Standards, DS 418, "Beregning af bygningers varmetab", translated: "Calculation of heat loss from buildings", 6th ed., 2002
- [13] L. Olsen and M. Hansen, "Varmeakkumulering i beton", translated: "Heat accumulation in concrete", Danish Ministry of the Environment, Environmental Protection Agency, 2007
- [14] S. Aggerholm, K. Grau, "Bygningers Energibehov", translated: "Buildings' Energy Demand", ed. 1.06.03, Danish Building Research Institute (SBI), 2005.
- [15] P. Nyeng, J. Østergaard, "Information and Communication Systems for Control-by-Price of Distributed Energy Resources and Flexible Demand", *IEEE Transactions on Smart Grid*, submitted for publication.

**Preben Nyeng** obtained the M.Sc. degree in industrial electrical engineering from the Technical University of Denmark (DTU), Lyngby, Denmark in 2000.

He was with Logos Design A/S from 2000 to 2006, developing embedded hardware and software systems, and related database and communications systems. Since 2006 he has been with the Centre for Electric Technology at DTU, as a PhD student in the field of intelligent energy systems, and related information and communication technology.

Mr. Nyeng is a member of CIGRE, the International Council On Large Electric Systems.

**Jacob Østergaard** (M'95–SM'09) obtained the M.Sc. degree in electrical engineering from the Technical University of Denmark (DTU), Lyngby, Denmark in 1995.

He was with Research Institute of Danish Electric Utilities for 10 years where he did research within power system transmission and distribution and was responsible for developing industrial-academic collaboration. Since 2005 he has been Professor and Head of Centre for Electric Technology, DTU. His research interests cover SmartGrids with focus on system integration of renewable energy and distributed energy resources, control architecture for future power system, and flexible demand.

Prof. Østergaard is serving in several professional organizations, boards and steering committees. He is head of the Danish experimental platform for electric power and energy, PowerLabDK, and he has been member of the EU SmartGrids advisory council. In 2009 he received the IBM Faculty Award.





## **[www.elektro.dtu.dk/cet](http://www.elektro.dtu.dk/cet)**

Department of Electrical Engineering  
Centre for Electric Technology (CET)  
Technical University of Denmark  
Elektrovej 325  
DK-2800 Kgs. Lyngby  
Denmark  
Tel: (+45) 45 25 35 00  
Fax: (+45) 45 88 61 11  
E-mail: [cet@elektro.dtu.dk](mailto:cet@elektro.dtu.dk)