

## Reduced Energy Consumption for Melting in Foundries

Skov-Hansen, Søren Peter; Tiedje, Niels Skat

*Publication date:*  
2008

*Document Version*  
Publisher's PDF, also known as Version of record

[Link back to DTU Orbit](#)

*Citation (APA):*  
Skov-Hansen, S. P., & Tiedje, N. S. (2008). Reduced Energy Consumption for Melting in Foundries. Kgs. Lyngby, Denmark: Technical University of Denmark (DTU).

## DTU Library

Technical Information Center of Denmark

---

### General rights

Copyright and moral rights for the publications made accessible in the public portal are retained by the authors and/or other copyright owners and it is a condition of accessing publications that users recognise and abide by the legal requirements associated with these rights.

- Users may download and print one copy of any publication from the public portal for the purpose of private study or research.
- You may not further distribute the material or use it for any profit-making activity or commercial gain
- You may freely distribute the URL identifying the publication in the public portal

If you believe that this document breaches copyright please contact us providing details, and we will remove access to the work immediately and investigate your claim.

# **Reduced Energy Consumption for Melting in Foundries**

**Ph.D. Thesis**  
**by**  
**Søren Skov-Hansen**

Supervisor: Niels Skat Tiedje, Associate Professor

Publication numbers: ISBN 978 – 87 – 90855 – 11 – 6

ELFOR PSO – 336 – 007

TM 06 – 07

Department of Manufacturing Engineering and Management

Technical University of Denmark



## **Preface**

This thesis partly fulfils the requirements for a Ph.D. degree at the Technical University of Denmark, DTU. The project has been financed by the Danish transmission system operator, Energinet.dk, and was carried out in collaboration with the three project partners Dania A/S, Frese Metal- and Steel Foundry A/S, and Disa Technologies A/S.

First of all I would like to thank the Danish transmission operator, Energinet.dk, for making it possible by financing the project.

I would like to express my gratitude to everybody who has been assisting me in theoretical as well as practical matters during the project.

I have been especially grateful for the close cooperation I have had throughout the entire period with all three partners in this project. In this regard I would like to thank everybody at Dania A/S and Per Lysdahl in particular for the warm welcome and the close assistance and corporation in every respect. Likewise I want to thank the people at Frese Metal- and Steel Foundry A/S and Geir Magne Selvik for a similar warm welcome and for the many discussions regarding the possibilities of horizontal moulding which at the beginning I only had a limited knowledge of. I would like to thank both foundries for the two very instructive week long stays I have had in the foundries. Also a special thank to Per Larsen and Niels Winther Rasmussen, DISA Technologies, for the many discussions, help, and input in all aspects.

I would like to express my gratitude to Professor Nick Green, University of Birmingham, for the discussions and the possibility of conducting experiments using the state of the art x-ray equipment at the University of Birmingham from which so many valuable results have been found.

I would like to mention Magmasoft, who has most kindly given me access to the latest versions of their simulation software that has helped to much better understanding of the processes. I would also like to mention Foseco, who has been supplying many of their products and shared their know-how through so many discussions.

I would like to thank my colleagues at the department for the help and support in so many practical matters conducting all of the experiments. Especially a thank to Ole Munch for the help in developing and constructing the many layouts and patterns, and Flemming Lehm for the help in constructing and welding so much equipment but also the many coffee breaks we have had in the mornings.

My sincere gratitude goes to my supervisor Niels Skat Tiedje, who has been of such a great help throughout the project in both theoretical and practical matters.

Søren Skov-Hansen

September 2007

## Abstract

By improving the gating technology in traditional gating systems it is possible to reduce the amount of metal to be re-melted, and hence reduce the energy consumption for melting in foundries.

Traditional gating systems are known for a straight tapered down runner a well base and 90° bends in the runner system. In the streamlined gating systems there are no sharp changes in direction and a large effort is done to confine and control the flow of the molten metal during mould filling.

Experiments in real production lines have proven that using streamlined gating systems improves yield by decreasing the poured weight compared to traditional layouts. In a layout for casting of valve housings in a vertically parted mould the weight of the gating system was reduced by 1,1kg which is a 20% weight reduction for the gating system. In a layout for horizontally parted moulds the weight of the gating system has been reduced by 3,7kg which is a weight reduction of 60% for the gating system.

The experiments casting valve housings in ductile iron also proved that it is possible to lower the pouring temperature from 1400°C to 1300°C without the risk of cold runs.

Glass plate fronted moulds have been used to study the flow of melt during mould filling. These experiments have also been used for studying the flow pattern when ceramic filters are used. The thorough study of the use of filters revealed that the metal passing through the filter is divided into a number of small jets. This proves that filters do not have the claimed positive effect on the flow of metal. The volumes necessary on either side of the filter are not filled till a backpressure is build up and results in formation of pressure shocks when backfilled. These pressure shocks result in more

turbulence inside the casting than the same gating system with no filter. Not using filters can mean a reduction in poured weight of 0,6kg.

To examine if the experiments using glass plate fronted moulds give representative results of how the melt flows in a real mould a series of experiments have been conducted using the x-ray facilities at the Metallurgy and Materials department at the University of Birmingham. The results proved that the glass plate do not have any large effect on the flow pattern during mould filling. It was also found that using fan gates only 1mm thick holds back slag and in this way works as a filter.

A complete set of guidelines for designing streamlined gating systems have been made in this project. Using these guidelines and combining standard geometries and the presented spreadsheet makes it possible for foundries to use streamlined gating systems in practice.

## Abstract in Danish

Ved at forbedre indløbsteknikken i traditionelle indløbssystemer er det muligt at reducere mængden af metal, der skal gensmeltes, og derved reducere energiforbruget til smeltning i støberierne.

Traditionelle indløbssystemer er kendt for at have en retlinjet konisk støbe tap, en brønd og 90° bøjninger i indløbssystemet. I strømlinede indløbssystemer er der ikke nogen skarpe retningsændringer, og en stor indsats er gjort for at kunne styre og kontrollere strømmingen af det flydende metal under formfyldningen.

Eksperimenter udført under produktionsforhold har bevist at brugen af strømlinede indløbs-systemer forbedrer udbyttet ved at reducere vægten af indløbssystemet sammenlignet med de traditionelle layouts. I et layout til støbning af ventilhuse i vertikalt delte forme blev vægten af indløbssystemet reduceret med 1,1kg, hvilket er en 20 % vægtreduktion for indløbs-systemet. I et layout til horisontalt delte forme er vægten af indløbssystemet blevet reduceret med 3,7 kg, hvilket er en vægtreduktion på 60 % for indløbssystemet.

Eksperimenterne med støbning af ventilhuse i SG-jern beviste også, at det er muligt at sænke støbetemperaturen fra 1400 °C til 1300 °C uden risiko for koldløbninger.

Glaspladeforsøg er blevet brugt til at studere strømmingen af smelte under formfyldning. Disse eksperimenter er også blevet brugt til at studere strømmingen, når keramiske filtre bliver brugt. Det grundige studie af brugen af filtre afslørede, at metallet, der passerer gennem filteret, bliver delt op i et antal små strømme. Dette beviser, at filtre ikke har den påståede positive indvirkning på strømmingen af metallet. De volumener, der er nødvendige på begge sider af filtret, er ikke fyldt, før et vist modtryk er opbygget, og når disse volumener fyldes, dannes der et tryk-chok, som



resulterer i mere turbulens inde i emnet end med det samme indløbssystem uden filter. Ved ikke at bruge filtre kan den samlede vægt nedbringes med 0,6kg.

For at undersøge om glaspladeforsøg giver repræsentative resultater af, hvordan smelten flyder i rigtige forme, er en serie af eksperimenter blevet udført ved brug af røntgen-faciliteterne hos instituttet Metallurgy and Materials på University of Birmingham. Resultaterne beviste, glaspladerne ikke har nogen større indflydelse på strømningsmønstret under formfyldningen. Det sås også, at vifteindløb med blot 1mm's tykkelse holder slagge tilbage og virker på denne måde som et filter.

Et komplet sæt af retningslinjer for design af strømlinede indløbssystemer er blevet udarbejdet i dette projekt. Ved at bruge disse retningslinjer og kombinere standard geometrier med det præsenterede regneark er det muligt for støberier at bruge strømlinede indløbs-systemer i praksis.

## Content

Preface.....	1
Abstract.....	3
Abstract in Danish.....	5
Content.....	7
1 Introduction .....	13
1.1 Purpose.....	14
1.2 Goal.....	14
1.3 Partners in this project.....	14
1.3.1 Dania A/S.....	14
1.3.2 Frese Metal- and Steel Foundry A/S .....	14
1.3.3 DISA Industries A/S .....	14
References.....	15
2 Theory in gating technology.....	17
2.1 Case study .....	17
2.2 Governing equations for the gating system.....	18
2.3 Principles in the traditional gating system .....	23
2.3.1 Dimensioning of the runners .....	23
2.3.2 The pouring cup.....	24
2.3.3 Further characteristics in the traditional layout .....	26
2.4 Principles in the streamlined gating system.....	27
2.5 The different parts of the streamlined gating systems .....	29
2.5.1 The fan gates.....	29
2.5.2 The bend under the casting.....	32
2.5.3 The horizontal runner .....	33
2.5.4 The bend below the down runner .....	33
2.5.5 The down runner.....	34
2.5.6 The funnel.....	34
2.5.7 The pouring cup.....	39
2.5.8 Dimensioning the streamlined gating system in praxis.....	40
References.....	41
3 Guidelines for designing a streamlined gating system.....	43
3.1 The general guidelines .....	43
3.2 Spreadsheet for designing a streamlined gating system .....	43
3.2.1 Sheet 1 – Geometry .....	44
3.2.2 Sheet 2 – Data.....	45
3.2.3 Sheet 3 – Fan gates .....	52
3.2.4 Sheet 4 – Calculations .....	55
3.3 Designing layouts with more than one casting .....	55
3.4 Standard geometries for the pattern plate .....	57
3.4.1 The funnel.....	58
3.4.2 The down runner.....	59

3.4.3	The bends.....	60
3.4.4	Using the standard geometries in the design of the layout.....	62
4	Simulations.....	63
4.1	Integrated modelling.....	63
4.2	Design optimization of the valve housing.....	64
4.3	Setting up filling simulations.....	67
4.3.1	The Solver.....	67
4.3.2	Filling definitions.....	68
4.3.3	Overflow.....	69
4.4	Filling simulations and comparison of the two layouts.....	70
4.5	Runner width.....	77
4.6	Conclusions.....	80
	References.....	81
5	Experimental facilities.....	83
5.1	Facilities at DTU.....	83
5.1.1	Module pattern plates.....	83
5.1.2	Sand Plant.....	85
5.1.3	Automatic moulding machine.....	86
5.1.4	Melting Furnaces.....	86
5.1.5	Magnesium treatment ladle.....	86
5.1.6	Spectrometer.....	87
5.2	Facilities at Dania A/S.....	87
5.2.1	Pattern making.....	87
5.2.2	Core shop.....	88
5.2.3	Moulding machine.....	88
5.2.4	Pouring device.....	88
5.2.5	Machining the castings.....	88
5.3	Facilities at Frese Metal- and Steel Foundry A/S.....	88
5.3.1	Core shop.....	88
5.3.2	Mould making.....	88
5.3.3	Furnaces for melting.....	89
5.3.4	Pouring.....	89
5.4	Facilities at University of Birmingham.....	89
5.4.1	Mould making.....	89
5.4.2	Furnace for melting.....	89
5.4.3	Pouring device.....	90
5.4.4	X-ray chamber.....	91
5.4.5	Control room.....	91
	References.....	94
6	Casting of a valve housing.....	95
6.1	Experimental casting using the streamlined layout.....	96
6.2	Comparison of the traditional- and the streamlined layout.....	98
6.2.1	Reduction in pouring time.....	98
6.2.2	Reduced minimum pouring temperature.....	98

6.2.3	Reduction in poured weight.....	99
6.2.4	Handling of the as-cast layouts.....	99
6.2.5	Machining of the castings.....	100
6.2.6	Microstructure analysis of the centre flange.....	101
6.3	Porosities .....	104
6.4	Experiments with glass plate fronted moulds .....	105
6.4.1	Results.....	106
6.4.2	Flow pattern .....	109
6.4.3	Velocities – using a pressed filter.....	112
6.4.4	Velocities – no filter .....	116
6.5	Conclusions .....	119
	References .....	122
7	Runner width .....	123
7.1	Designing the layout .....	123
7.2	Results from glass plate experiments.....	126
7.3	Conclusions .....	129
	References .....	131
8	Filtration .....	133
8.1	The reasons for discussions.....	133
8.2	The different kinds of filters .....	134
8.3	Mechanisms in filtration .....	134
8.4	Filter prints .....	136
8.5	Glass plate experiments .....	139
8.5.1	The different layouts.....	139
8.6	Results from the glass plate experiments.....	140
8.6.1	Investigation of the mould filling .....	141
8.6.2	The first melt passing through the filters.....	150
8.7	Recommendations regarding the use of filters.....	152
	References .....	155
9	Experiments using X-Ray.....	157
9.1	The layout and the pattern plates .....	157
9.2	Experimental procedure .....	159
9.2.1	The mould .....	159
9.2.2	Magnesium treatment .....	161
9.2.3	Recording using X-Ray .....	161
9.3	Experimental results.....	161
9.3.1	The effect of how the melt is poured.....	169
9.3.2	The effect of directing the flow of metal towards a core .....	173
9.3.3	Comparing the flow of ductile iron and gray iron .....	174
9.3.4	Using the in-gate for filtration .....	175
9.3.5	Comparison with results from glass plate fronted moulds .....	176
9.4	Conclusions .....	182
	References .....	184
10	Streamlined gating systems in horizontal moulding.....	185

10.1	The layouts .....	185
10.1.1	The traditional layout.....	185
10.1.2	The streamlined layout .....	186
10.2	The moulds.....	188
10.3	Results .....	189
10.3.1	Reduction in the poured weight.....	191
10.4	Conclusions .....	191
11	Potential energy savings .....	193
11.1	Reduction in the poured weight .....	193
11.2	Reduction in scrap rate.....	195
11.3	Potentially no heat treatment.....	195
11.4	Lower pouring temperature.....	196
11.4.1	Energy savings.....	196
11.4.2	Further benefits.....	198
11.5	Possibility for foundries to offer more thin walled castings .....	199
	References .....	200
12	Discussion .....	201
12.1	First melt entering the casting .....	201
12.2	Velocities during mould filling .....	203
12.3	Changing to the streamlined gating systems.....	204
12.3.1	Pouring cup and funnel.....	205
12.3.2	Lowering of the pouring temperature .....	205
12.4	Filtration .....	206
12.4.1	Misinterpretation of surface defects .....	207
12.5	Ways of investigating flow patterns.....	210
12.5.1	Using the results from these experiments .....	211
12.6	Considerations regarding design .....	212
	References .....	213
13	Conclusions.....	215
13.1	Recommendations for future work .....	217
14	Appendices.....	219
14.1	Appendix 1 – Simulation .....	219
14.1.1	Temperature scale for the simulation results.....	219
14.1.2	The traditional gating system .....	220
14.1.3	The streamlined gating system .....	224
14.1.4	Runner width .....	228
14.2	Appendix 2 - Casting of a valve housing.....	232
14.2.1	Streamlined gating system – Pressed filter.....	232
14.2.2	Streamlined Gating system – Without filter.....	241
14.3	Appendix 3 – Runner width .....	247
14.4	Appendix 4 – Filtration .....	252
14.4.1	Vertical 1 (a foam filter is used).....	252
14.4.2	Vertical 2 (a foam filter is used).....	257
14.4.3	Horizontal (a foam filter is used).....	261

14.5	Appendix 5 – Experiments using X-Ray .....	266
14.5.1	Ductile iron 1 .....	266
14.5.2	Ductile iron 3 .....	269
14.5.3	Ductile iron 4 .....	272
14.5.4	Glass plate experiments – mould 1 .....	275



# 1 Introduction

In foundries all over the world a lot of effort is done to minimize costs in the production to increase their competitiveness. At the same time the foundries must live up to the increased demands for high quality castings. One way of dealing with these requirements for lower costs is to try to minimize the amount of molten metal being poured into each mould without reducing the quality. To do this a large effort is being done to minimize the size of feeders by for example using different kinds of insulating- or exothermic sleeves.

Another area of research in which large savings can be made is in the design of the gating system. Previous work has shown that the traditional way of designing gating systems creates high inconsistency in flow patterns during filling. This inconsistency can be seen in the way that three moulds made under the exact same conditions with a traditional layout will not necessarily give the same result. Per Larsen presents a number of guidelines for confining and controlling the melt using streamlined gating systems for the purpose of producing thin-walled castings. [Ref. 1-1]

This project is based on these results, principles and recommendations. The aim for this project is somewhat different in the way that the focus is not primarily on designing gating systems for only thin walled castings but more general for use with also heavier castings. The main objective in this project is to use the principles in the streamlined gating systems to reduce the weight of the gating system relative to the traditional layouts. At the same time the consistency in the flow patterns during filling from one mould to the next are to be improved, this again reduces the scrap rate. This project is also meant to help and make it easier for foundries in general to use the streamlined gating system on an everyday basis since this is how the largest savings are achieved.



### 1.1 Purpose

The purpose of the project is to minimize the energy consumption for re-melting in foundries.

### 1.2 Goal

The goal for the project is to find and describe a new set of design rules for designing of streamlined gating systems for use on an every day basis in foundries. By using streamlined gating systems instead of more traditional gating systems the poured weight is to be reduced hence reducing the amount of metal to be re-melted and in this way fulfilling the purpose of the project.

### 1.3 Partners in this project

A brief presentation of the three project partners are given here.

#### 1.3.1 Dania A/S

Dania A/S was established in 1947 and is an independent iron foundry producing high quality castings in both gray iron and ductile iron. Dania A/S also offers all kinds of machining of the castings. [Ref. 1-2]

#### 1.3.2 Frese Metal- and Steel Foundry A/S

The foundry has more than 50 years of experience in sand casting in corrosion resistant material as bronze, aluminium bronze and stainless steel. Mould sizes up to a maximum of 3000mm x 3000mm x 2000mm floor moulding NO-bake process. [Ref. 1-3]

#### 1.3.3 DISA Industries A/S

DISA Industries is a complete supplier to the foundry industry and offers a wide range of foundry systems, equipment, technical expertise and service support. [Ref. 1-4] DISA is probably best known for the automatic moulding machine for vertically parted moulds, the Disamatic.

## References

**[Ref. 1-1] Larsen, Per – Iron Melt Flow in Thin Walled Sections Cast in Vertically Parted Green Sand Moulds. Technical University of Denmark 2004**

**[Ref. 1-2] [www.dania-as.dk](http://www.dania-as.dk)**

**[Ref. 1-3] [www.fresemetal.dk](http://www.fresemetal.dk)**

**[Ref. 1-4] [www.disagroup.com](http://www.disagroup.com)**



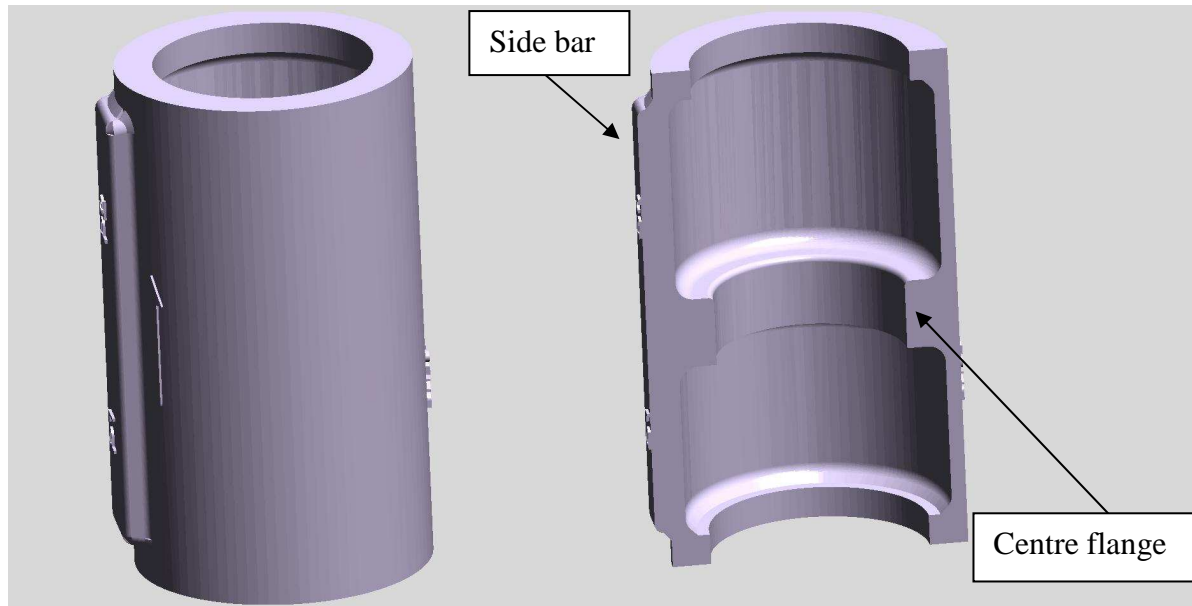
## 2 Theory in gating technology

The purpose of, and the most important reason for having and designing the gating system is obviously to transport the molten metal into the mould cavity. At first this sounds fairly simple however at the same time the gating system must fulfil a series of other demands as well. One of the first demands is that the gating system must ensure that the flow of the melt should be as calm and coherent as possible without being so slow that the melt solidifies before the mould is filled. The gating system should also be designed in a way that reduces jets, formation of air pockets and vena contracta as much as possible. Very often a poorly designed gating system can cause oxide formation and gas entrapment which reduces the quality of the casting. Beside this, a beneficial heat distribution in the castings is desired to ease the need for feeding and improve the efficiency of the feeders. At the same time the gating system should weigh as little as possible to improve the ratio of weight of castings produced to weight of metal poured better known as “yield”.

In this project only gravity driven mould filling in sand moulds is concerned. To ease the understanding when discussing gating systems the term ‘casting’ will be used for the combined actual part to be cast and the feeders. The gating system has to be able to fill both the parts and the feeders so there is no reason to distinguish between them here.

### 2.1 Case study

A valve-housing for automatic balancing valves was chosen for a case study. The reason for this choice was that the valve housing is to be cast in ductile iron on a Disamatic, and bronze and perhaps stainless steel in horizontally parted moulds. This means that the same geometry has the interest of all three partners in the project. Using the valve housing as a case study also means that in the following the valve housing will be used as example for the explanations and descriptions. A three dimensional representation of the valve housing is seen in Figure 2-1.



**Figure 2-1 To the left: A three dimensional representation of the valve housing. To the right: The valve housing cut vertically.**

The actual valve is to be positioned on the centre flange. There is a side bar on the valve housing that might cause problems regarding feeding and shrinkage porosities especially by the centre flange.

### 2.2 Governing equations for the gating system

When designing gating systems it is necessary to use mathematical descriptions of the fluid flow of the molten metal to be able to predict flow patterns during the mould filling. The full description can be found using Navier-Stokes equation. [Ref. 2-1] However from a practical point of view when designing gating systems some more simple equations is necessary and the full or the more precise description can then be used in computer simulations for the mould filling to be simulated.

When designing the gating system the first part to be considered is the down runner. The reason is that the height of the down runner and the fall of the molten metal determine the velocity of the melt. There are two different approaches to find the expression for the velocity. Both of these are based on the principle of energy conservation. In the down runner the melt is falling as just mentioned, meaning that

the velocity can be found from the change in potential- and kinetic energy. The equation is seen in Eq. 2-1.

Kinetic energy = Potential energy

$$\text{Eq. 2-1} \quad \begin{aligned} \frac{1}{2} \cdot M \cdot v^2 &= M \cdot g \cdot h \\ v &= \sqrt{2 \cdot g \cdot h} \end{aligned}$$

Where:

$M$  : Mass

$v$  : Velocity

$g$  : Gravity acceleration

$h$  : Height of down runner

A different way of expressing the velocity is to use Bernoulli's equation seen in Eq. 2-2. Bernoulli's equation expresses that in any two points 1 and 2 the total energy is the same.

$$\text{Eq. 2-2} \quad p_1 + \rho \cdot g \cdot h_1 + \left( \frac{\rho \cdot v_1^2}{2} \right) = p_2 + \rho \cdot g \cdot h_2 + \left( \frac{\rho \cdot v_2^2}{2} \right)$$

Where:

$p$  : Pressure in point 1 and 2

$\rho$  : Density of the melt

$h$  : Height in point 1 and 2

$v$  : Velocity in point 1 and 2

Using Eq. 2-2 for designing a down runner in ventilated moulds the pressure at both of the two points is the atmospheric pressure. The velocity in the first point is considered to be zero. Using the height in one of the two points as zero level the Bernoulli equation boils down to Eq. 2-3 [Ref. 2-2] which is the same expression as in Eq. 2-1.

$$\text{Eq. 2-3} \quad v = \sqrt{2 \cdot g \cdot h}$$

Where:

$h$ : Height of down runner

To achieve a more realistic result calculating the velocity a loss factor ‘ $m$ ’ is necessary. This factor can be seen as representing the percentage of loss in velocity due to friction between melt and mould wall and due to pressure drop. The new expression for the velocity is then seen in Eq. 2-4. The value for the loss factor is based upon experience, but the value 0,5 is normally used. The expression in Eq. 2-4 is also known as Torricelli’s law.

$$\text{Eq. 2-4} \quad v = (1 - m) \cdot \sqrt{2 \cdot g \cdot h}$$

The amount of molten metal  $G$  [kg] passing a certain cross section with the area  $A$  per time  $t$  is given by Eq. 2-5.

$$\text{Eq. 2-5} \quad \frac{G}{t} = \rho \cdot A \cdot v$$

Hence, expressing the velocity using Eq. 2-4.

$$\frac{G}{t} = \rho \cdot A \cdot (1 - m) \sqrt{2 \cdot g \cdot h}$$

⇕

$$\text{Eq. 2-6} \quad A = \frac{G}{t \cdot \rho \cdot (1 - m) \sqrt{2 \cdot g \cdot h}}$$

Where:

$G$ : Weight of casting and runner after the chosen cross section

$t$ : Filling time for the casting and runner after the chosen cross section

Eq. 2-6 is normally used for defining the area of the governing cross section in the gating system. This means that this cross section is used as reference for defining of all other necessary cross sections. There are many ways of finding the filling time but often the filling time is chosen based on experience in the individual foundry. However in literature there are simple empirical based formulas for estimating an optimal filling time. [Ref. 2-5]

The relation between the areas in two cross sections x and y in the down runner can be found if the principle of continuity [Ref. 2-2] in Eq. 2-7 is used in combination with Eq. 2-4 giving Eq. 2-8.

$$\text{Eq. 2-7} \quad A_x \cdot v_x = A_y \cdot v_y$$

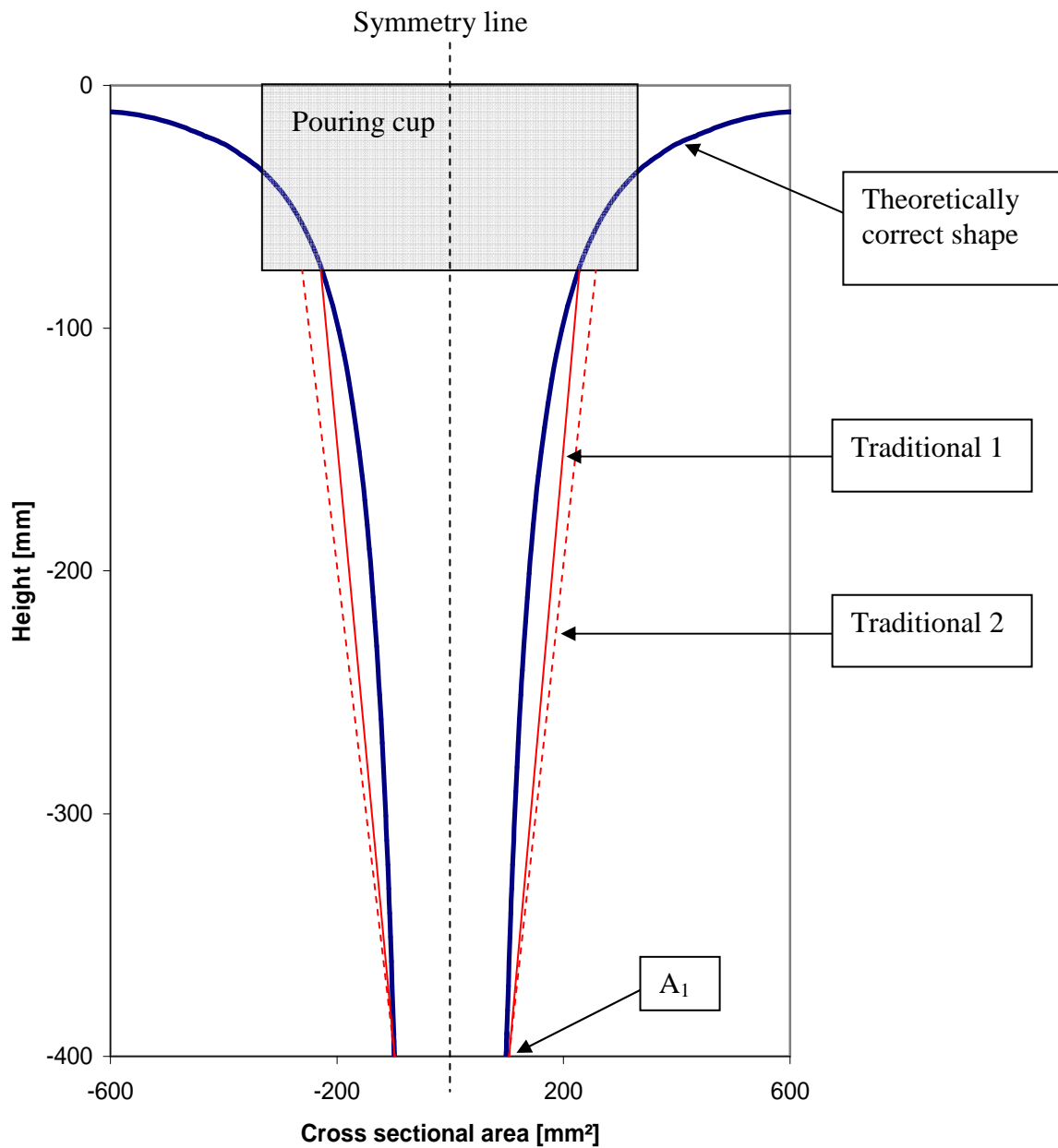
$$\text{Eq. 2-8} \quad A_y = A_x \sqrt{\frac{h_x}{h_y}}$$

A graphically representation of the result from using Eq. 2-8 to calculate the theoretically correct cross sectional areas for all heights in the down runner can be seen in Figure 2-2. The two graphs ‘Traditional 1’ and ‘Traditional 2’ also seen in Figure 2-2 represents two very common ways of designing the down runner in the traditional gating system. These geometries are used in the attempt to resemble the correct shape using a straight tapered geometry.

In both traditional and in streamlined gating systems it is common to use the exit of the down runner named ‘A<sub>1</sub>’ in Figure 2-2 as the governing area for the gating system and will hence be the same in both types of layouts. In the design called ‘Traditional 1’ the top of the down runner is dimensioned using the same dimensions as found using the theoretically correct dimensions. The graphs show that in this design the down runner ends up having cross sectional areas larger than what the stream of molten metal possibly can keep filled. A design like ‘Traditional 1’ therefore creates a gap of air



leading to gas entrapment in the melt. The gap will not be filled until sufficient backpressure is built up in the remaining layout.



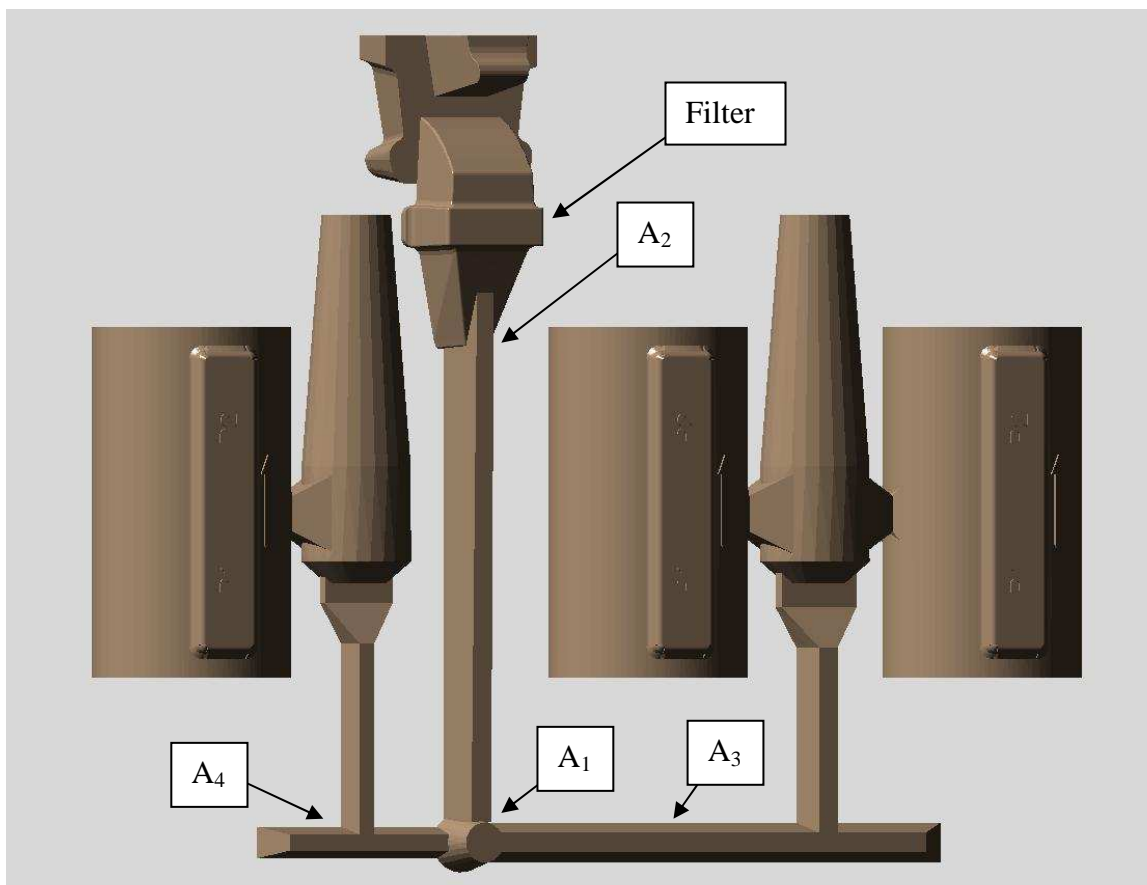
**Figure 2-2 Graphical representation of height plotted against cross sectional area in the down runner. The curves ‘Traditional 1’ and ‘Traditional 2’ represent two designs of straight tapered down runners.**

The graph ‘Traditional 2’ show how it traditionally often is attempted to avoid these problems by increasing the cross sectional area of the top of the down runner 20% to 25%. Both of these solutions for designing the down runner are compromises leading

to an unnecessary increase in the poured weight. The idea in the streamlined gating systems is to avoid these compromises and in a simple way achieve the desired geometries of all cross sections in the down runner hence avoid gas entrapment and reduce the poured weight as much as possible.

### 2.3 Principles in the traditional gating system

An example of a traditional layout for a gating system can be seen in Figure 2-3. This layout represents the original layout for casting the valve housing in the case study using a Disamatic automatic moulding machine.



**Figure 2-3** The traditional gating system.

#### 2.3.1 Dimensioning of the runners

It was mentioned in the previous section that it is typical to use the cross sectional area  $A_1$  as the governing area. This means that  $A_1$  is used as a basis to define all the remaining cross sectional areas. Other places in the gating system can be used for the

governing cross section instead, but the exit of the down runner is very commonly used. The area for the cross section  $A_2$  is found using equation Eq. 2-8 following one of the prior described principles ‘Traditional 1’ or ‘Traditional 2’.

The cross sectional areas  $A_3$  and  $A_4$  in the horizontal runners seen in Figure 2-3 are normally found by multiplying the area at the base of the down runner  $A_1$  by a factor between two and six depending on the alloy and experience in the foundry. [Ref. 2-3]

### 2.3.2 The pouring cup

The size and shape of the pouring cup is meant to accommodate the way the melt is being poured. In many foundries the pouring is done manually from a ladle in a crane. In these cases melt is poured from one side and the pouring cup is designed to reduce splashing of melt when poured and to make it as easy for the operator to pour as directly and precisely in every mould as possible.

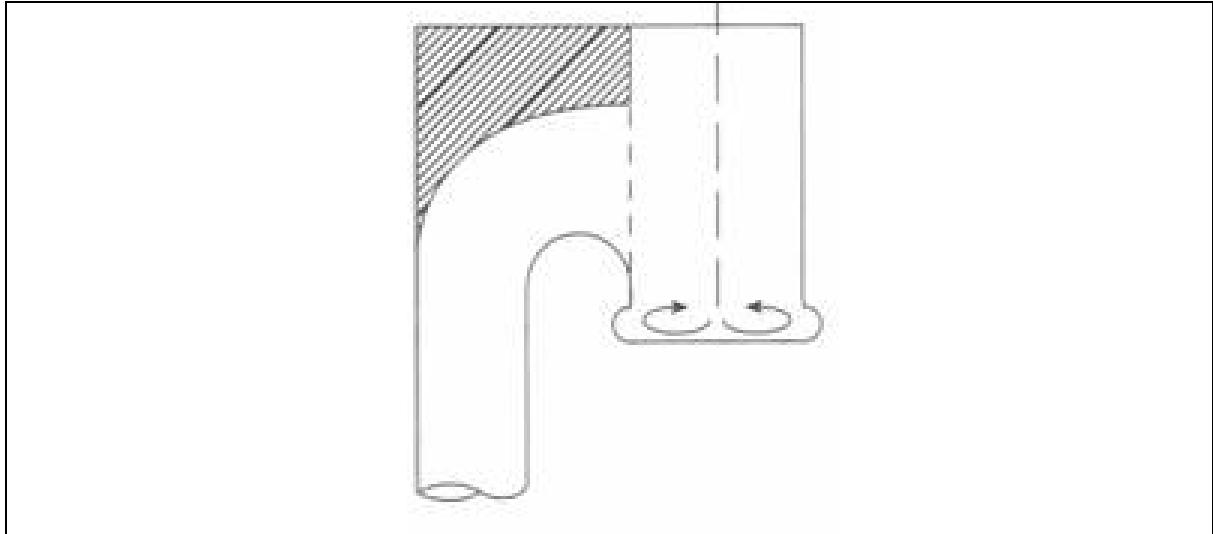
Using an automatic pouring device sets different requirements to the shape and dimension of the pouring cup. Most automatic pouring devices use a stopper and the melt is hence being poured directly from above the pouring cup and not from the side as was the case for the manual pouring. The pouring cup is the only part of the gating system that can actually be seen when the mould is closed. Therefore the pouring cup is often used to sense the position of the mould. Knowing the exact position of the mould the automatic pouring device positions it self correctly above the mould. Often the automatic positioning and the pouring from right above the mould mean that the size of the pouring cup can be smaller than for the manual pouring improving yield.

The layout in Figure 2-3 is an example of the latter. The pouring cup is specially designed for the positioning of the specific automatic pouring device correctly above the mould.

There are many recommendations as to how a pouring cup should be designed however most of these designs do not prevent vena contracta in the upper part of the down runner. The problem for most pouring cup designs is that a large effort is done to try and decrease the velocity by preventing the melt to be poured directly down the down runner. The pouring cup in Figure 2-3 is an example of this. The flow pattern in this pouring cup is investigated more thoroughly in the chapter 'Filtration'. An additional often recommended example of a pouring cup design is seen in Figure 2-4. This design is claimed to ensure that the filling rate will be controlled by the running system and not the pouring of the melt under the condition that the basin is maintained full. [Ref. 2-4]

The problem in the design of the pouring cup in Figure 2-4 is that when reaching the height in the basin where the melt can flow to the down runner it will. The volume of this initial melt to reach the down runner will under no circumstance be sufficient to fill the cross section of the down runner. So unless it is possible to pour fast enough to completely fill the entire geometry shown in Figure 2-4 instantaneously it will not be possible to keep the down runner full. To pour the molten metal in this way must be considered to be extremely difficult. This is especially because the pouring must be slowed down just as instantaneously as it was begun. If the pouring is not slowed down to the exact same flow rate as the gating system is designed for, the melt will just flow all over the top of the mould having an already full pouring cup. If the pouring is slowed down too much and the level of melt in the pouring cup drops below the top of the bend, the down runner will no longer be kept full. Hence it is highly unlikely that it is possible to keep the down runner full from the beginning to the end of pouring using the pouring cup shown.

Designing a pouring cup that fulfils all the desired properties is not easy and therefore a wide range and very individually designed pouring cups are also seen used in the foundries.



**Figure 2-4 [Ref. 2-4] The figure show a pouring cup often recommended.**

### 2.3.3 Further characteristics in the traditional layout

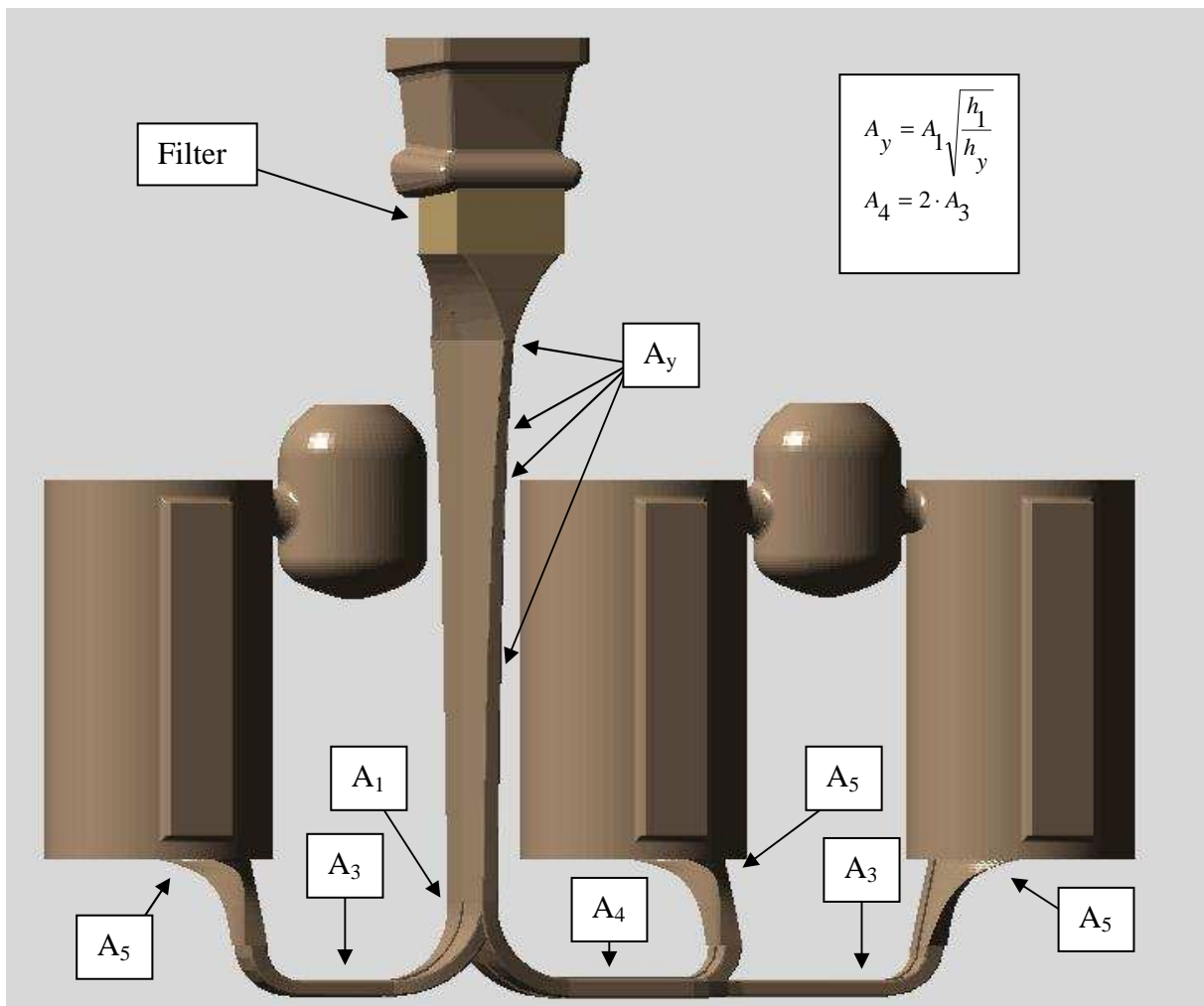
The 90° bends in the running system is another characteristic in the traditional gating systems. These bends are known to cause the formation of vena contracta resulting in air entrapment and oxide formation. A well base at the bottom of the down runner can help to avoid some of these problems, but it is not always sufficient and the problem might still occur. [Ref. 2-4]

It is common to use dead-ends in the horizontal runner in the traditional gating systems in an additional attempt to reduce the velocity of the melt. It has been shown that this approach does not work very well. When the melt reaches the dead ends in the horizontal runner, a pressure shock upwards into the in-gates is formed. [Ref. 2-5] In the traditional layout here the pressure shock results in a jet of melt into the feeders. This result can be seen in the results from the simulations as will be described and presented in the chapter ‘Simulations’.

One characteristic connected to the traditional gating systems is that flow patterns are never identical even though experiments are carried out under identical circumstances. [Ref. 2-5] [Ref. 2-6]

## 2.4 Principles in the streamlined gating system

In the previous sections some of the downsides of the traditional gating system were pointed out. In order to avoid these problems a more streamlined approach in the gating design is needed. An example of a streamlined gating system can be seen in Figure 2-5. It should be mentioned that the valve housing here has also been optimized compared to the castings in the traditional layout and therefore the need for feeding has been reduced. The redesign of the valve housing is described in the chapter 'Simulations'.



**Figure 2-5** The streamlined gating system

The basic idea behind the streamlined gating system is to use the surface tension and boundary layer friction of the molten metal to keep the front of the flowing molten

metal coherent during the mould filling. This is done primarily by keeping the runner width as small as possible. In addition to this, all 90° bends are avoided and more soft curves are used instead. In this way it has been shown that it is possible to keep the runner system filled at all times. [Ref. 2-5]

When using Eq. 2-6 one of the basic assumptions is that the gating system is kept full at all times. Mostly however using the traditional layout this is not the case often due to vena contracta that creates an artificial choke. This often means that the pouring time becomes longer than anticipated leading to cold runs, air entrapments, oxide formation and other defects. Often it means that the solution to the problem is to enlarge the down runner leading to an increase in the poured weight.

When designing the down runner the same equations are used as for the traditional layout. The area  $A_1$  is found using Eq. 2-6. But when designing the rest of the down runner Eq. 2-8 is used with much smaller steps from top to exit. Like it was explained previously the aim is to achieve a down runner with geometries as close to the theoretically correct shape as possible. How the correct shape is achieved in practice using standard geometries is explained in the chapter 'Guidelines for designing a streamlined gating-system'.

Calculating the velocity using Eq. 2-4 the loss factor is very important. Normally the value of the loss factor is chosen based on experience but often a value of 0,5 is used. In this way there is no difference between the streamlined- and the traditional gating system. However it is important to bear in mind that it is an average value for the loss through the entire gating system. It has been found that the loss factor is between 0,1-0,2 in the down runner and the loss factor in fan gates can be up to 0,6-0,8. In this way the velocity of the melt is decreased just before entering the mould cavity. It has been found through these experiments that a good estimate of an average value for loss factor is 0,5. [Ref. 2-8]

The in-gates in the streamlined gating systems are designed in the same way as fan gates used in high pressure die casting. These types of in-gates are being used in the streamlined gating systems because they have proven beneficial in two ways. First of all the loss factor is increased as just described. Secondly the fan gates gives uniform melt velocities over the cross sections and the front of the flowing molten metal is kept coherent. [Ref. 2-5] [Ref. 2-9]

As mentioned in the description of the traditional gating system the placement of the filter here creates a lot of splashing and turbulence. In the streamlined gating system this has been decreased by pouring directly into the filter. The use of filters and the flow patterns around filters are investigated and described in the chapter 'Filtration'. More important is the part of the gating system just below the filter. In order to keep the down runner filled at all times during filling it is necessary to be sure the cross section at the very top is filled. If this is not the case it is not possible to keep the rest of the down runner filled. By using some of the principles once again from the design of fan gates in the design of a funnel a full down runner is achieved as will be described in the following.

However it is important to emphasise that no matter what principles are used for the design of the gating system and pouring cup it is not possible to maintain the down runner full through out the mould filling if the initial melt is not sufficient to fill the top cross section of the down runner and keep this section full.

### **2.5 The different parts of the streamlined gating systems**

In the following a description of the different parts and their purpose needed to construct an entire streamlined gating system is found.

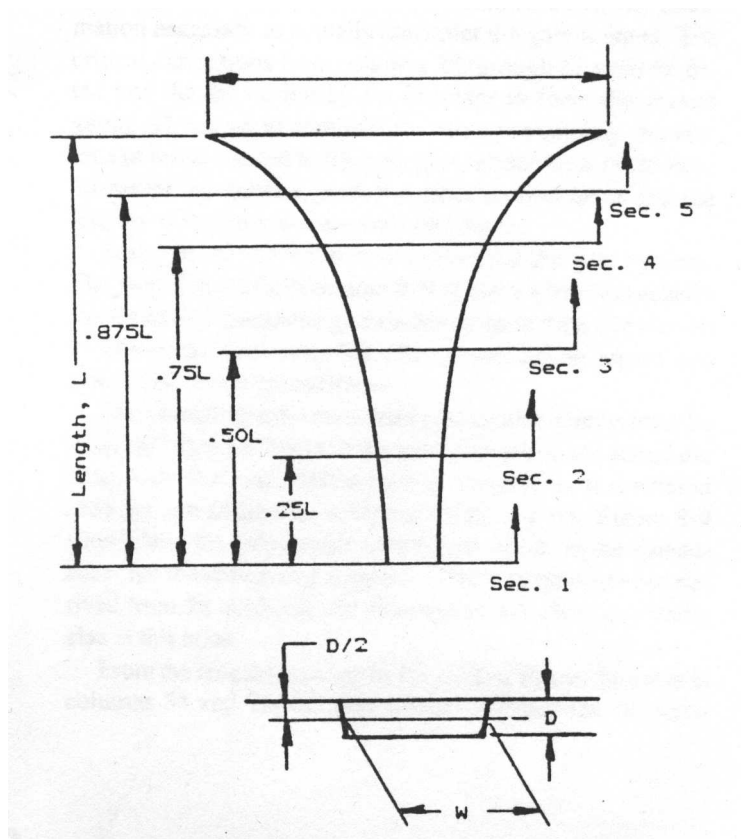
#### **2.5.1 The fan gates**

The design and use of fan gates originates from high pressure die casting. The design of the fan gate is more complex than the remaining parts of the gating system in the



streamlined gating system. First of all the fan gate has to be connected to the casting in a way that gives a beneficial heat distribution in the casting after mould filling. In this way mechanical properties and feeding can be enhanced. Secondly it should be kept in mind that the cross-sectional area throughout the fan gate should be either the same or increased relatively to the top cross-section of the 'bend under the casting'. At the same time the connection to the casting should be as thin as possible. These two parameters will both help to decrease the velocity of the melt. Thirdly the connection between the fan gate and the casting should be in a way that makes it as easy as possible to remove the gating system from the casting.

When designing a fan gate the geometry is normally divided into six sections. Each section is defined by a length or a height, a depth and a width. A general representation of the six sections can be seen in Figure 2-6.



**Figure 2-6 [Ref. 2-10] The six sections that defines the geometry of a fan gate.**

The size and geometry of 'section 1' is found from the top of the bend under the casting and 'section 6' depends on considerations mentioned above. In this way the areas, depth and width are known and can be used to define the remaining cross sections. In this way the design of fan gates used for streamlined gating systems differ from the fan gates used in high pressure die casting. Normally a ratio 'r' would be chosen for defining the depth of the fan gate, but for the purpose here the depth is based on the geometry of the runners.

### The areas of the sections

The area of section 3 is found using Eq. 2-9:

$$\text{Eq. 2-9} \quad A_{Sec.3} = \frac{A_{Sec1} + A_{Sec6}}{2}$$

The area of section 2 is found using Eq. 2-10:

$$\text{Eq. 2-10} \quad A_{Sec2} = \frac{A_{Sec1} + A_{Sec3}}{2}$$

The area of section 4 is found using Eq. 2-11:

$$\text{Eq. 2-11} \quad A_{Sec4} = \frac{A_{Sec3} + A_{Sec6}}{2}$$

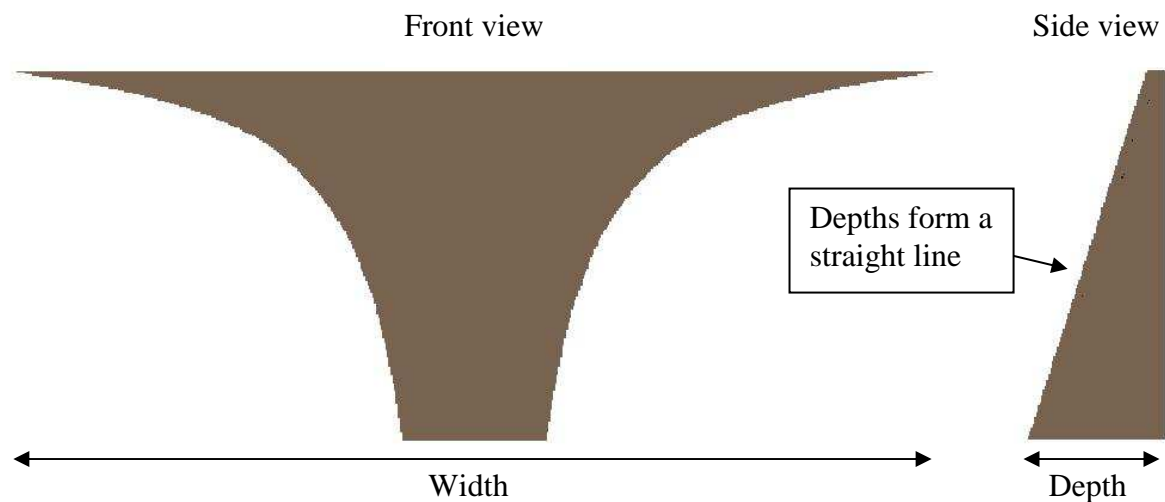
The area of section 5 is found using Eq. 2-12:

$$\text{Eq. 2-12} \quad A_{Sec5} = \frac{A_{Sec4} + A_{Sec6}}{2}$$

### The depth of the sections

The depth of the sections is found using almost the same equations as for the areas. The only difference is that the calculations are based on the depth of section 1 and section 6 instead of the areas. This procedure ensures that the depths in combination

forms a straight line hence a flat surface. This can be seen in the example shown in Figure 2-7.



**Figure 2-7 Example of a fan gate. The side view shows that the depths form a straight line.**

### The width of the sections

For each of the sections the width is found dividing the area of the section by the depth of the section as shown in Eq. 2-13.

**Eq. 2-13**      
$$\text{Width} = \frac{\text{Area}}{\text{Depth}}$$

### 2.5.2 The bend under the casting

The purpose of this bend is to create a smooth transition from the horizontal runner to the fan gate. Also in this part of the gating system in theory it is possible to increase the cross-sectional area because now not only the continuity equation and the friction loss due to the bend, but also the gravity starts to help decrease the velocity. It should of course be mentioned that the Bernoulli equation in reality is only valid for flow along a streamline. [Ref. 2-5] Also in this case a further experimental study is needed

in order to quantize exactly how much the cross-section can be increased before a breakdown of the melt front occurs.

### **2.5.3 The horizontal runner**

In the horizontal runner the melt is no longer falling and therefore the velocity is no longer increasing as in the down runner and the bend below the down runner. This means that at least in theory, using the continuity equation Eq. 2-7 it is possible to decrease the velocity by increasing the cross-sectional area throughout the horizontal runner. Further experimental studies needs to be done to quantize exactly how much the cross-sectional area can be increased while still keeping the melt front coherent depending on velocity, the initial size of the runners, and so forth.

### **2.5.4 The bend below the down runner**

When designing the bend below the down runner it is necessary to see this bend as an extension of the down runner. What is meant is that also this part of the gating system is designed using Eq. 2-8. This is due to the fact that the melt can be considered as free falling and the velocity has not yet been reduced. The bends takes up more space on the pattern plate than a sharp 90° bend does. Therefore experiments using glass plate fronted moulds have been done to investigate the influence of the radius on the flow pattern. A layout was made in which the bend under the down runner could easily be changed. Figure 2-8 shows the final frame from each of the bends.

The three radii investigated were 75mm, 50mm and 25mm. The results showed no problems in any of the experiments in keeping the front of the melt coherent. Differences in the flow patterns in the casting as a result the difference in the bends were not seen either [Ref. 2-8] These experiments proved that using softer bends instead of 90° bends do not necessarily take up too much space on the pattern plate.



**Figure 2-8 To the left: Radius 75mm. In the middle: Radius 50mm. To the right: Radius 25mm.**

The cross-sectional area and geometry of the top of the bend need to be the same as the cross-section at the base of the down runner whereas the cross-sectional area of the bottom of the bend is found using Eq. 2-8. The geometry for the base cross-section does not have to be exactly the same as used in the top of the bend. An example could be that the width can be decreased as long as the cross sectional area is correct.

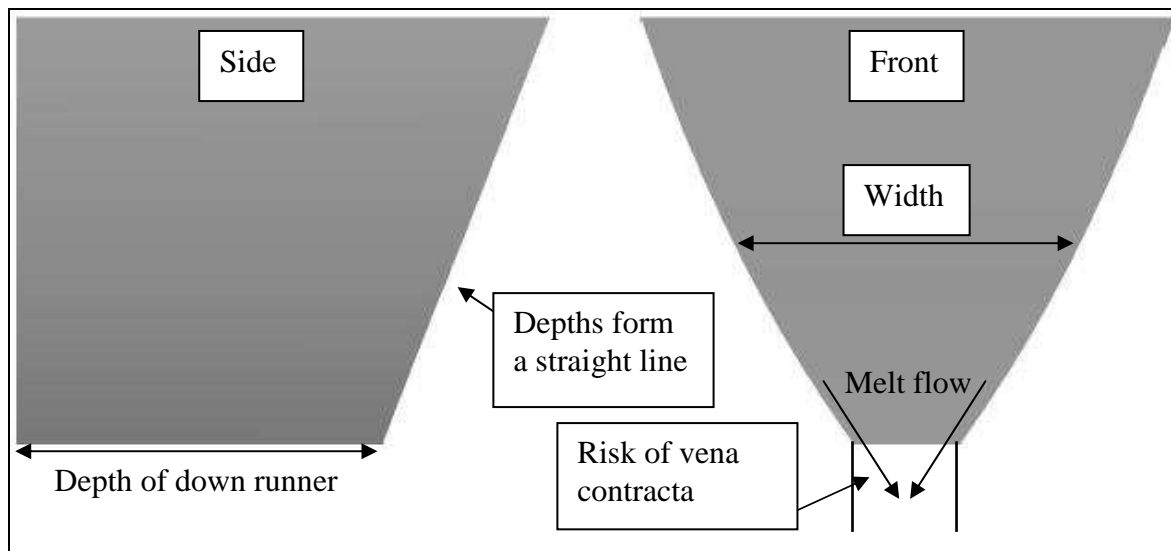
### 2.5.5 The down runner

When designing a down runner it is very important that the cross sectional area at all heights is as close to the result of Eq. 2-8 as possible. By doing this it is possible to keep the down runner full. If the down runner is full the velocity of the melt is also decreased. This is because the friction between the melt and the mould is slowing down the melt.

### 2.5.6 The funnel

The purpose of the funnel is to guide especially the very first melt poured in such a way that the cross section of the top of the down runner is filled from the beginning to the end of the mould filling. If the top of the down runner is not filled at all times it is not possible to keep the rest of the down runner full either. This will lead to a highly

turbulent flow and gas entrapment in the remaining gating system. Therefore it is important to design the funnel correctly and a straight tapered design is not sufficient. A funnel that eliminates the problem of vena contracta has been developed. The principles in this funnel are described in the following.

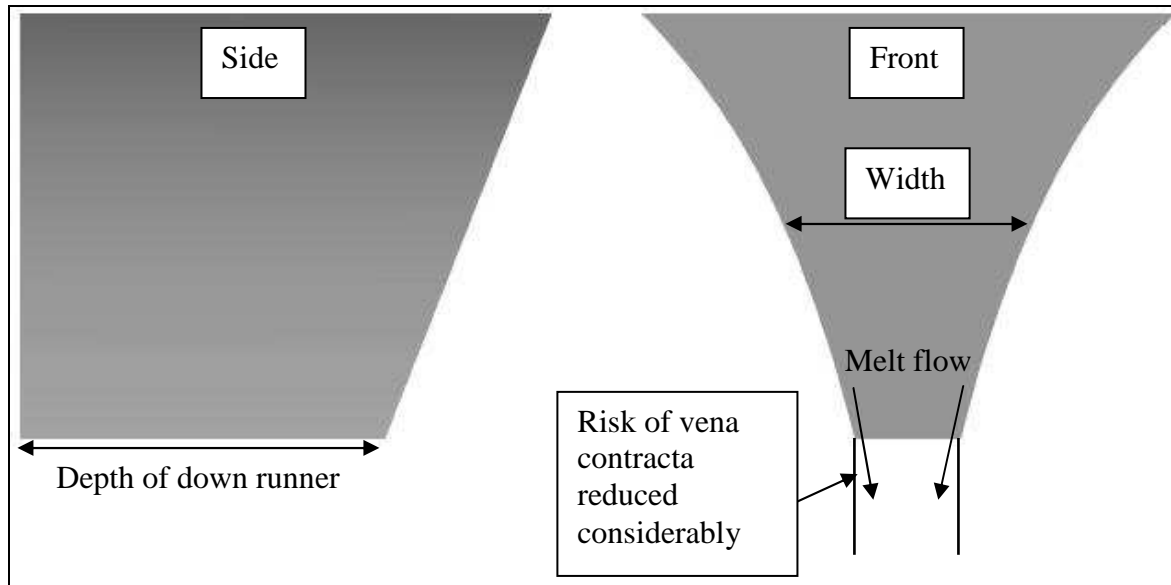


**Figure 2-9 Schematic representation of a funnel designed in-correctly. The resulting geometry if the design principles for fan gates are used for a funnel in which the depth of the down runner is smaller than the depth of the upper part of the funnel.**

Fan gates have proven to result in uniform melt velocities over the cross section of the exit as mentioned earlier. Therefore the principles in the design of the fan gates are also used in the design of the funnel. In the design of the funnel there is an exception from the principles in the design of fan gates in how the width of the cross sections is calculated. This is because a problem occurs in the attempt to achieve the desired shape of the funnel in the case when the depth of the top of the down runner is smaller than the depth required in the top of the funnel. The resulting geometry if no precautions are taken is seen in Figure 2-9.

As indicated the geometry in Figure 2-9 will not direct the flow of molten metal vertically downwards. This will result in vena contracta in the top of the down runner creating an artificial choke and it will not be possible to keep the down runner full. A

schematic representation of a correctly designed funnel is seen in Figure 2-10. This geometry also resembles the geometry suggested by Friedrich Nielsen. [Ref. 2-7]



**Figure 2-10 Schematic representation of a funnel designed correctly.**

The precautions necessary to achieve the correct and desired shape of the funnel in all cases are described in the following.

The size and geometry of section 1 and 6 of the fan gate is determined by the geometries that the fan gate ties together. In the same way the size and geometry of the top- and base sections of the funnel is determined by the base of the pouring cup and the top of the down runner. In both the fan gates and the funnel the depths of the sections form a straight line and the areas of the sections in the funnel are found using the same equations as used for the fan gates.

The only difference in the designs is found when calculating the width of the sections. The desired shape of the funnel can only be found in the case that the depth of the top of the down runner is larger than the depth of the base of the pouring cup. However, this is not always the case. To avoid this problem it is necessary to introduce two

artificial dimensions. The following is only used for calculating the width of the cross sections and has no influence on the already calculated dimensions of the depths.

First an artificial depth of the top of the down runner larger than the depth of the base of the pouring cup is introduced. Along with this artificial depth, an artificial cross sectional area is calculated based on the real width of the top of the down runner and the artificial depth.

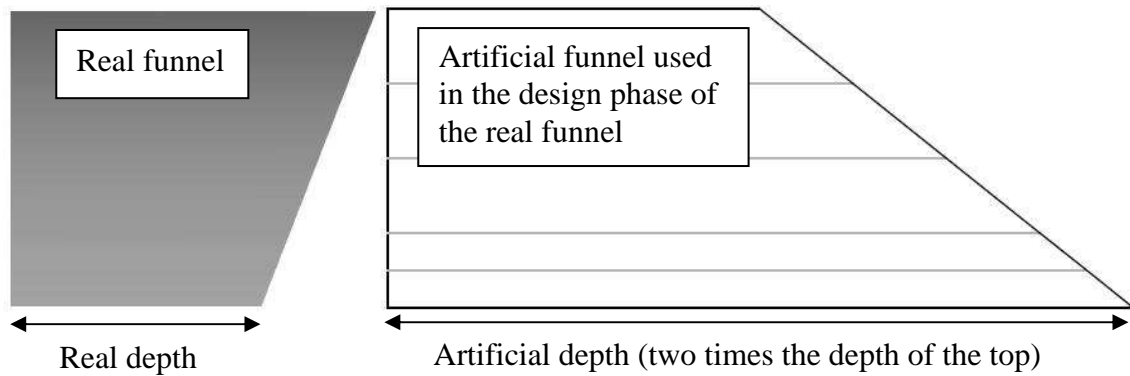
The artificial area of the top of the down runner is then used in Eq. 2-9 as  $A_{\text{sec6}}$  together with the real cross sectional area of the base of the pouring cup as  $A_{\text{sec1}}$ . On this basis artificial cross sectional areas for the remaining sections are found using Eq. 2-10, Eq. 2-11 and Eq. 2-12.

The artificial depth of the top of the down runner and the real depth of the base of the pouring cup is used for calculating artificial depths for the sections. This is done in the exact same way as the depths are calculated for the fan gates. A representation of the artificial depths is seen to the right in Figure 2-11.

The artificial areas and artificial depths are then used for calculating what is going to be the real widths of each section. This is done using Eq. 2-13.

These approaches in designing the funnel corresponds to assuming a necessity for distributing the melt across a section much deeper, hence larger than in reality, and then only use part of the geometry.

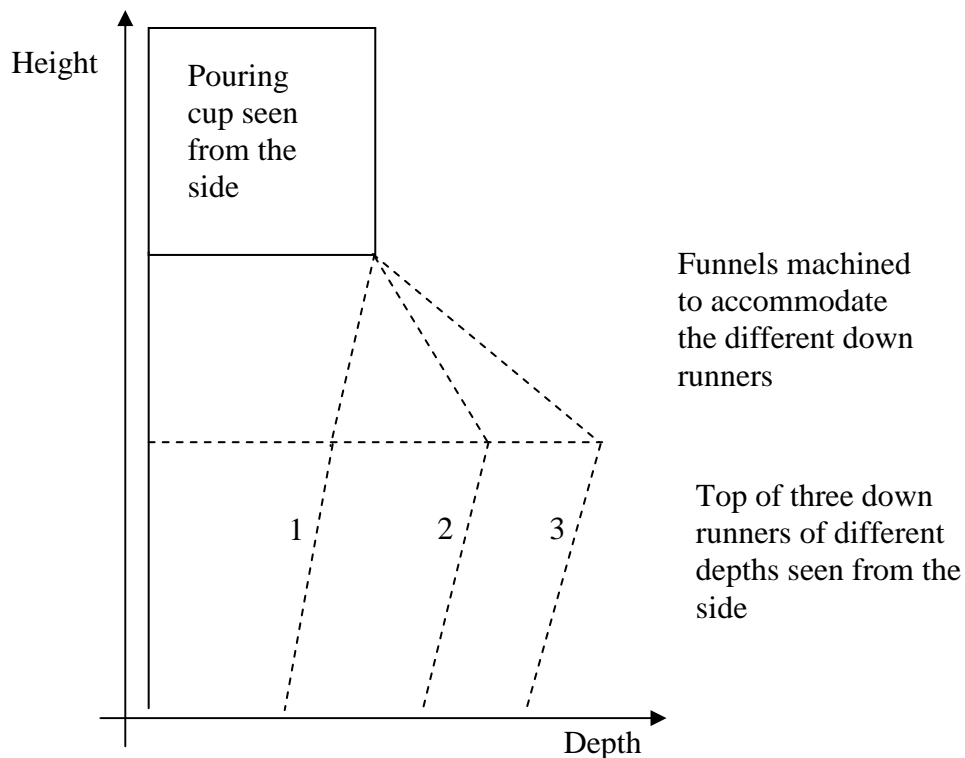




**Figure 2-11 To the left: The real funnel with the correct depths. To the right: The funnel using the artificial depths used in the design phase for achieving the widths for the correct shape of the real funnel.**

In the spread sheet later presented in the chapter ‘Guidelines for designing a streamlined gating system’ this approach for designing the funnel is used in all cases when the depth of down runner is less than twice the depth of the top of the funnel. Doing this and keeping the geometry of the base of the pouring cup constant together with a constant width of the down runner makes it possible to use a standard geometry when manufacturing the funnel. This is due to the fact that for all layouts in which the depth of the down runner is less than twice the depth of the base of the pouring cup the width of each section will be the same. In this way the only dimension that changes from one layout to another is the depth meaning that the right side in Figure 2-11 is machined to resemble the left side.

The use of a standard geometry for the funnel will be described later. However a schematic view of how only the depth of the funnel is to be changed to accommodate down runners of different depths is seen in Figure 2-12. In all cases the same pouring cup is used.



**Figure 2-12** The figure shows schematically how the depth of the funnel is modified to accommodate down runners of different depth but always with the same pouring cup

### 2.5.7 The pouring cup

Changing from the traditional layout to the streamlined gating system does not necessarily mean that the design of the actual pouring cup needs to be revisited. As previously mentioned the pouring cup is often designed to accommodate the specific circumstances in the foundry. There is one major difference however between the ways the pouring cup is designed in the two types of layout. In the streamlined gating system a funnel ensures that the melt is poured directly down the down runner. This approach completely contradicts the traditional idea behind designing a pouring cup described earlier. However the idea in using this design is that no vena contracta is formed and the down runner really is maintained full throughout the filling of the mould. When the down runner is not kept full the melt is subjected to a free fall whereas if the down runner is full the friction between the melt and the mould will help reducing the velocity.

The use of the funnel means a large change in the flow pattern in the pouring cup which again means that the traditional design of the pouring cup might no longer be the most beneficial. In many cases a re-design of the pouring cup can mean a further reduction in the poured weight of the layout.

### **2.5.8 Dimensioning the streamlined gating system in praxis**

From the descriptions of the streamlined gating systems here it is clear that it takes some more calculations for finding all the correct dimensions. Obviously it takes more time to do all these calculations than to do the comparatively very few calculations for the traditional gating system. However in the following chapter ‘Guidelines for designing a streamlined gating system’ a spread sheet and a number of standard geometries are presented, that makes the dimensioning and the design of the streamlined gating system easy to use on an every day basis in the foundries.

## References

[Ref. 2-1] Hattel, Jesper – **Fundamentals of Numerical Modelling of Casting Processes, 1. Edition 2005, Polyteknisk Forlag, Kgs. Lyngby, Denmark**

[Ref. 2-2] Fredriksson, H., Åkerlind, U. – **Materials Processing during Casting, John Wiley & Sons, Ltd. 2006**

[Ref. 2-3] Tiedje, N., Skov-Hansen, S. – **Streamlined Gating Systems with Improved Yield – Dimensioning and Experimental Validation, World Foundry Congress, 2006**

[Ref. 2-4] Campbell, J. – **Castings Practice The 10 rules of casting. Elsevier Butterworth-Heinemann, 2004**

[Ref. 2-5] Larsen, Per – **Iron Melt Flow in Thin Walled Sections Cast in Vertically Parted Green Sand Moulds. Technical University of Denmark, 2004**

[Ref. 2-6] Xu, Z.A., Mampaey, F. – **Computer Simulations of Mould Filling for Horizontal Castings and Its Experimental Validation, European Journal of Mechanical Engineering, Vol. 40, 1995**

[Ref. 2-7] Nielsen, F. – **Gieß- und Anschnitttechnik, Grundlagen und Anwendung, einer Methode, Gießerei-Verlag G.m.b.H, Düsseldorf, 1979**

[Ref. 2-8] Holt, H.T., Møller, R.H. – **Tab ved formfyldning – Numerisk simulering og eksperimenter, Bachelor Thesis, Technical University of Denmark, 2006**

[Ref. 2-9] Skov-Hansen, S. – **Formfyldning af Meget Tyndvægget Støbegods, Technical University of Denmark, 2003**

[Ref. 2-10] Herman, E.A. – **Gating Die Casting Dies, North American Die Casting Association (NADCA), 1996**



### **3 Guidelines for designing a streamlined gating system**

To make it easier for foundries in practice to benefit from the advantages of using streamlined gating systems it is necessary to set and give a number of tools and guidelines. It is important to underline that the cost for changing from using the traditional layouts to the streamlined layouts are to be kept at a minimum. In the following it will be described more precisely what is necessary in order to design the layout, and to make the patterns for the streamlined gating systems.

#### **3.1 The general guidelines**

In the previous chapter 'Theory in gating technology' there are a number of guidelines for the design of a streamlined gating system. In short general terms these are as follows:

- Use a funnel to guide the molten metal down the down runner
- Avoid sharp bends in the runner system
- Keep the width of the runners as small as possible
- Use fan gates to decrease velocity and control the flow during filling

#### **3.2 Spreadsheet for designing a streamlined gating system**

To help designing the streamlined gating systems a spreadsheet has been made that gives the precise positions and geometries and sizes for the different cross-sections. This makes it a lot easier to design a good streamlined gating system in which the general guidelines presented are fulfilled. The spreadsheet is made for a gating system for a layout with only one casting, but it is simple to use the spreadsheet in the design process for more complicated layouts. How to make a design for more castings is explained as well.

### 3.2.1 Sheet 1 – Geometry

This sheet shows a picture of the basic gating system which can be designed using the spreadsheet. This sheet can be seen in Figure 3-1. It should be mentioned, though it is not shown in Figure 3-1, in case it is desired to have a filter in the layout it is assumed to be placed on top of the funnel meaning between the pouring cup and the funnel. In this way the filter is used as the base of the pouring cup so that the melt is poured directly into the filter. Neither the pouring cup nor the filter is shown. The reason for this is that a filter is not always needed and the pouring cup is often designed by the individual foundry as described in the passage ‘The pouring cup’ in the chapter ‘Theory in gating technology’.

### Design of layouts for vertically parted moulds

The geometry of the layout is seen below:

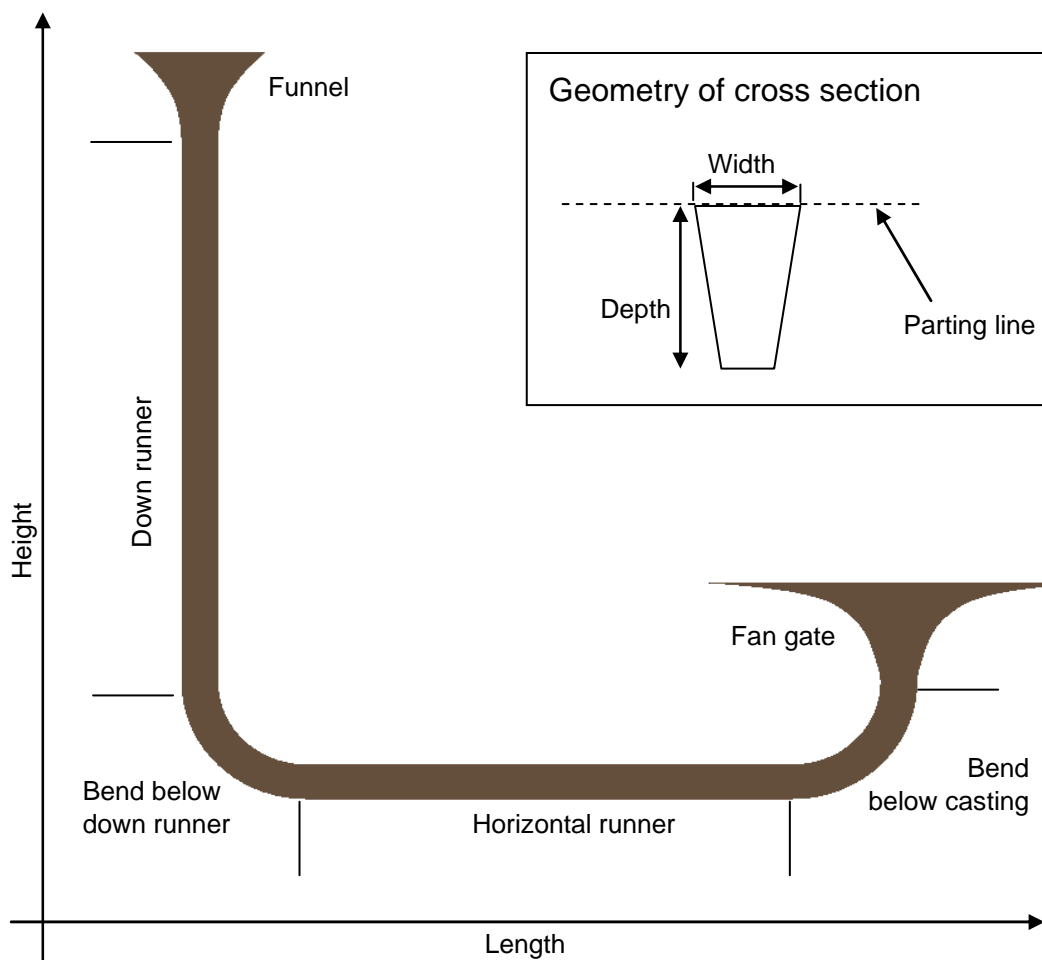


Figure 3-1 Sheet 1 – Geometry

#### 3.2.2 Sheet 2 – Data

The first part of the Data-sheet is for typing in all the parameters needed for the design of a gating system. These parameters include the size of the mould, the density of the melt and the radii of the different bends. A screenshot of this part of the sheet can be seen in Figure 3-2. If space to place a filter is needed, then the height needed for the filter-print is typed in together with the dimension of the outlet of the filter-print used. This means that ‘depth’ and ‘width’ of the filter is not the actual size of the filter but the size of the cross-section for the melt to exit the filter. The reason for this perhaps slightly confusing way of describing the filter is that the filter prints also might vary from one foundry to the other. Therefore the geometry of the outlet of the filter-print is used and not the actual size of the filter.

In the remaining part of ‘Sheet 2 – Data’ the calculated geometries for the gating system is found. The here found values describe the geometries and the exact positions of all the necessary cross-sections. These can be seen in Figure 3-3 to Figure 3-6. In the columns ‘Height’ one should bear in mind that the values presented are the heights measured from the very base of the mould.



## Design of streamlined gating system

Vertical moulding

DATA		
<i>Casting:</i>		
<b>Name of the casting</b>		
<i>Mould</i>	Height	500 mm
	Width	600 mm
<i>Pouring cup</i>	Height	80 mm
	Depth	80 mm
	Width	80 mm
<i>Filter</i>	Height	25 mm
	Depth	50 mm
	Width	50 mm
<i>Funnel</i>	Height	40 mm
<i>Slip angle</i>		3°
<i>Maximum runner width</i>		10 mm
<i>Rounding of bend below down sprue</i>		25 mm
<i>Rounding of bend below casting</i>		25 mm
<i>Expansion of crosssectional area in rounding below casting (only pos)</i>		0 %
<i>Height from base of mould to base of runner</i>		30 mm
<i>Length of horizontal runner</i>		150 mm
<i>Expansion of crosssectional area in horizontal runner</i>		0 %
<i>Number of mm between measurements in horizontal runner</i>		50 mm
<i>Fan gate</i>	Height	40 mm
<i>Expansion in crosssectional area</i>		20 %
<i>Connection with casting</i>	Width	206 mm
	Depth	1 mm
<i>Weight of casting and feeders</i>		5 kg
<i>Wallthickness of casting</i>		5 mm
<i>Height of casting</i>		250 mm
<i>Width of casting</i>		250 mm
<i>Estimated weight of runners</i>		1 kg
<i>Loss factor in runner system</i>	m	0,5
<i>Density of the molten metal</i>	$\rho$	7000 kg/m <sup>3</sup>
<i>Suggestions for pouring times</i>	Cast iron	3,3 s
	Bronze	5,1 s
	Aluminium	16,4 s
	Steel	4,4 s
<i>Chosen pouring time</i>	t	3,3 sec
<i>Governing area (Base of down runner)</i>		177 mm <sup>2</sup>

Figure 3-2 Sheet 2 – Data

**Measurement for cross sections:**

Down runner and first bend

Place	Height	Area	Width	Depth SP	Depth PP
Top of pouring cup	500 mm	6400 mm <sup>2</sup>	80,0 mm	80,0 mm	
Base of pouring cup	420 mm	6400 mm <sup>2</sup>	50,0 mm	50,0 mm	
Base of filter	395 mm	2500 mm <sup>2</sup>	50,0 mm	50,0 mm	
	385 mm	1952 mm <sup>2</sup>	34,0 mm	47,1 mm	
	375 mm	1404 mm <sup>2</sup>	23,3 mm	44,3 mm	
	365 mm	856 mm <sup>2</sup>	15,7 mm	41,4 mm	
	360 mm	582 mm <sup>2</sup>	12,7 mm	40,0 mm	
Top of down runner	355 mm	308 mm <sup>2</sup>	10,0 mm	38,6 mm	
	335 mm	289 mm <sup>2</sup>	10,0 mm	35,4 mm	
	315 mm	273 mm <sup>2</sup>	10,0 mm	32,9 mm	
	275 mm	247 mm <sup>2</sup>	10,0 mm	29,2 mm	
	235 mm	228 mm <sup>2</sup>	10,0 mm	26,4 mm	
	195 mm	212 mm <sup>2</sup>	10,0 mm	24,3 mm	
	155 mm	200 mm <sup>2</sup>	10,0 mm	22,6 mm	
	115 mm	189 mm <sup>2</sup>	10,0 mm	21,3 mm	
	75 mm	180 mm <sup>2</sup>	10,0 mm	20,1 mm	
Base of down runner	60 mm	177 mm <sup>2</sup>	10,0 mm	19,7 mm	
Base of bend	35 mm	172 mm <sup>2</sup>	10,0 mm	19,1 mm	

**Figure 3-3 Sheet 2 – Data. Positions and measurements for all parts of the funnel, down runner and the bend below the down runner**

**Measurement for cross sections:**

Horizontal runner

Place	Length	Area	Width	Depth SP	Depth PP
Start of horizontal runner	0 mm	172 mm <sup>2</sup>	10,0 mm <sup>2</sup>	19,1 mm	
	50 mm	172 mm <sup>2</sup>	10,0 mm <sup>2</sup>	19,1 mm	
	100 mm	172 mm <sup>2</sup>	10,0 mm <sup>2</sup>	19,1 mm	
End of horizontal runner	150 mm	172 mm <sup>2</sup>	10,0 mm <sup>2</sup>	19,1 mm	

**Figure 3-4 Sheet 2 – Data. Positions and measurements for all parts of the horizontal runner**

**Measurement for cross sections:**

Bend below casting and fan gate - Fan gate: sides are kept as straight lines

Place	Height	Area	Width	Depth SP	Depth PP
Start of bend below casting	35 mm	172 mm <sup>2</sup>	10,0 mm	19,1 mm	
End of bend below casting	60 mm	172 mm <sup>2</sup>	10,0 mm	19,1 mm	
	70 mm	180 mm <sup>2</sup>	59,1 mm	3,1 mm	
	80 mm	189 mm <sup>2</sup>	108,1 mm	1,8 mm	
	90 mm	198 mm <sup>2</sup>	157,2 mm	1,3 mm	
	95 mm	202 mm <sup>2</sup>	181,7 mm	1,1 mm	
Connection to casting	100 mm	206 mm <sup>2</sup>	206,3 mm	1,0 mm	

**Figure 3-5 Sheet 2 – Data. Positions and measurements for all parts of the bend below the casting and the fan gate. Here the sides of the fan gate are kept as straight lines.**

**Measurement for cross sections:**

Bend below casting and fan gate - Fan gate: depth is kept as a straight line

Place	Height	Area	Width	Depth	SP	Dybde	PP
Start of bend below casting	35 mm	172 mm <sup>2</sup>	10,0 mm	19,1 mm			
End of bend below casting	60 mm	172 mm <sup>2</sup>	10,0 mm	19,1 mm			
	70 mm	180 mm <sup>2</sup>	13,1 mm	14,6 mm			
	80 mm	189 mm <sup>2</sup>	19,3 mm	10,1 mm			
	90 mm	198 mm <sup>2</sup>	36,1 mm	5,5 mm			
	95 mm	202 mm <sup>2</sup>	62,1 mm	3,3 mm			
Connection to casting	100 mm	206 mm <sup>2</sup>	206,3 mm	1,0 mm			

**Figure 3-6 Sheet 2 – Data. Positions and measurements for all parts of the bend below the casting and the fan gate. Here the depth of the fan gate is kept as a straight line.**

As can be seen in the above figures the geometries for all cross-sections are defined by six parameters. The first column indicates where in the gating system the section is. The second column indicates the exact position height or lengthwise of the cross-section being in consideration. The third column tells the area of the cross-section in square millimetres. The fourth column tells the width of the cross-section as it is defined in Figure 3-1. The last two columns show the depth of the cross-section on either of the two pattern plates. Most pattern workshops prefer that the gating system is all on one pattern plate. However having a certain maximum runner width and a fixed draft angle means, that it is not always physically possible to have the desired area on one plate. This is taken into account as described in the following. The spreadsheet is designed in a way so that if a certain size for the governing area in the base of the down runner means that the cross-sectional area in the top of the down runner becomes larger than what is possible; half the gating system is placed on the other pattern plate. When for instance half the gating system is placed on the other pattern plate this does not include the pouring cup and the possible filter. The funnel is modified as will be described later in this chapter so that the molten metal is still guided to fill the entire cross-section of the top of the down runner.

In the design of the down runner the spreadsheet takes into account that the changes in the cross-sectional area according to Eq. 2-8 are the largest from the top and approximately one third down. The spreadsheet therefore calculates the cross-sections in this part of the down runner with 20mm intervals. In the rest of the down runner the cross-sections are calculated with 40mm intervals.

In the first part of 'Sheet 2 – Data' the user is asked to type in the length of horizontal runner, the expansion of the cross-sectional area in the horizontal runner and the distance between measurements. The reason for the two first of these parameters should be fairly obvious but the third might not be. The parameter is used in case the pattern workshop needs to know the measurements more places along the runner. If these measurements are not needed, one can just set the value for this third parameter

to a value larger than the length of the horizontal runner. In this way only the positions and measurements for the two ends of the runner are given.

#### **3.2.3 Sheet 3 – Fan gates**

The sheet called ‘Fan gates’ are meant to be a help when designing fan gates for specific purposes. In case the spreadsheet is used for designing gating systems with more than one casting it is often necessary to make these special designs. In other cases where a round fan gate is needed for the layout this sheet will also be used. The sheet is seen in Figure 3-7 and Figure 3-8.

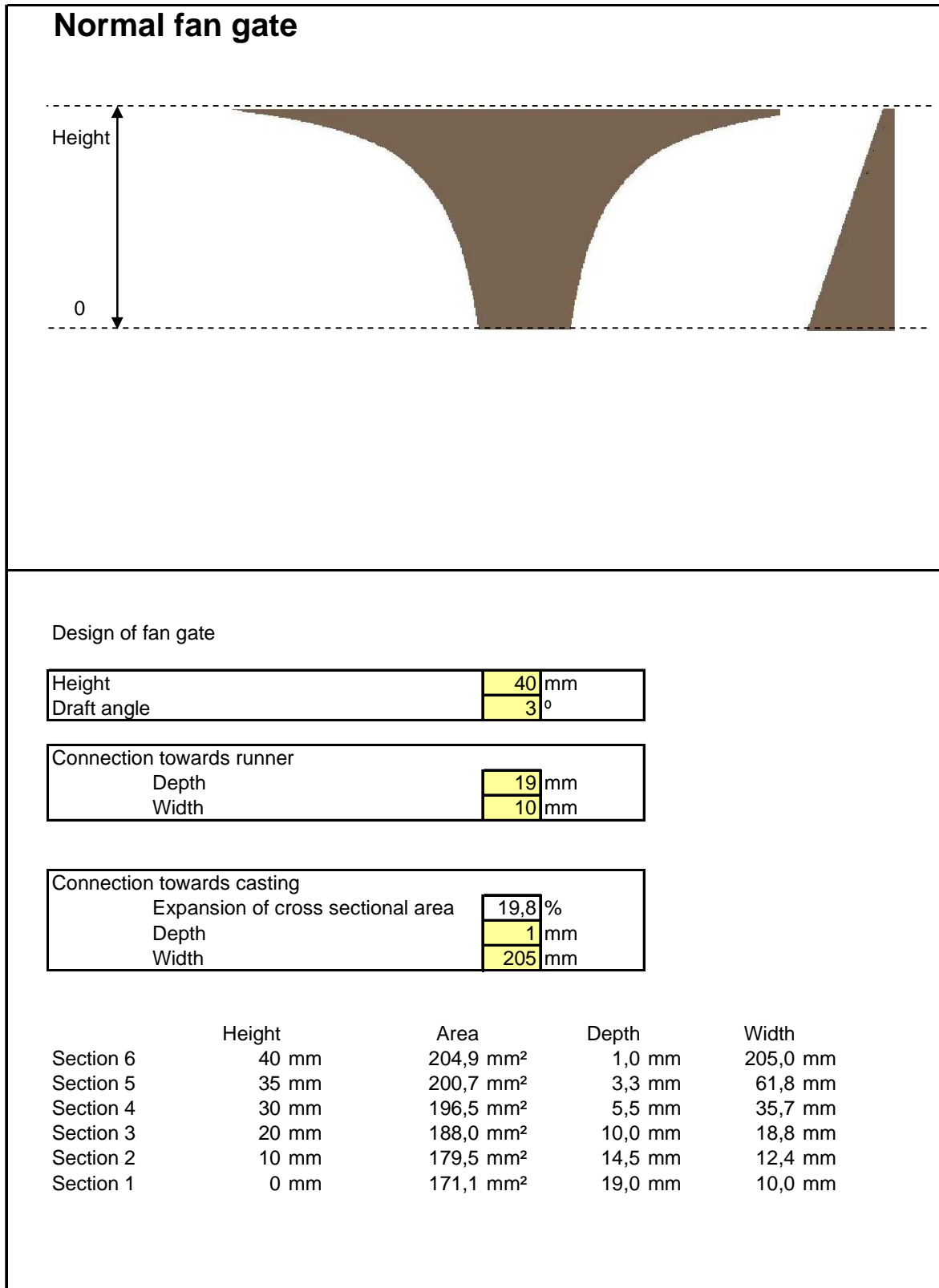
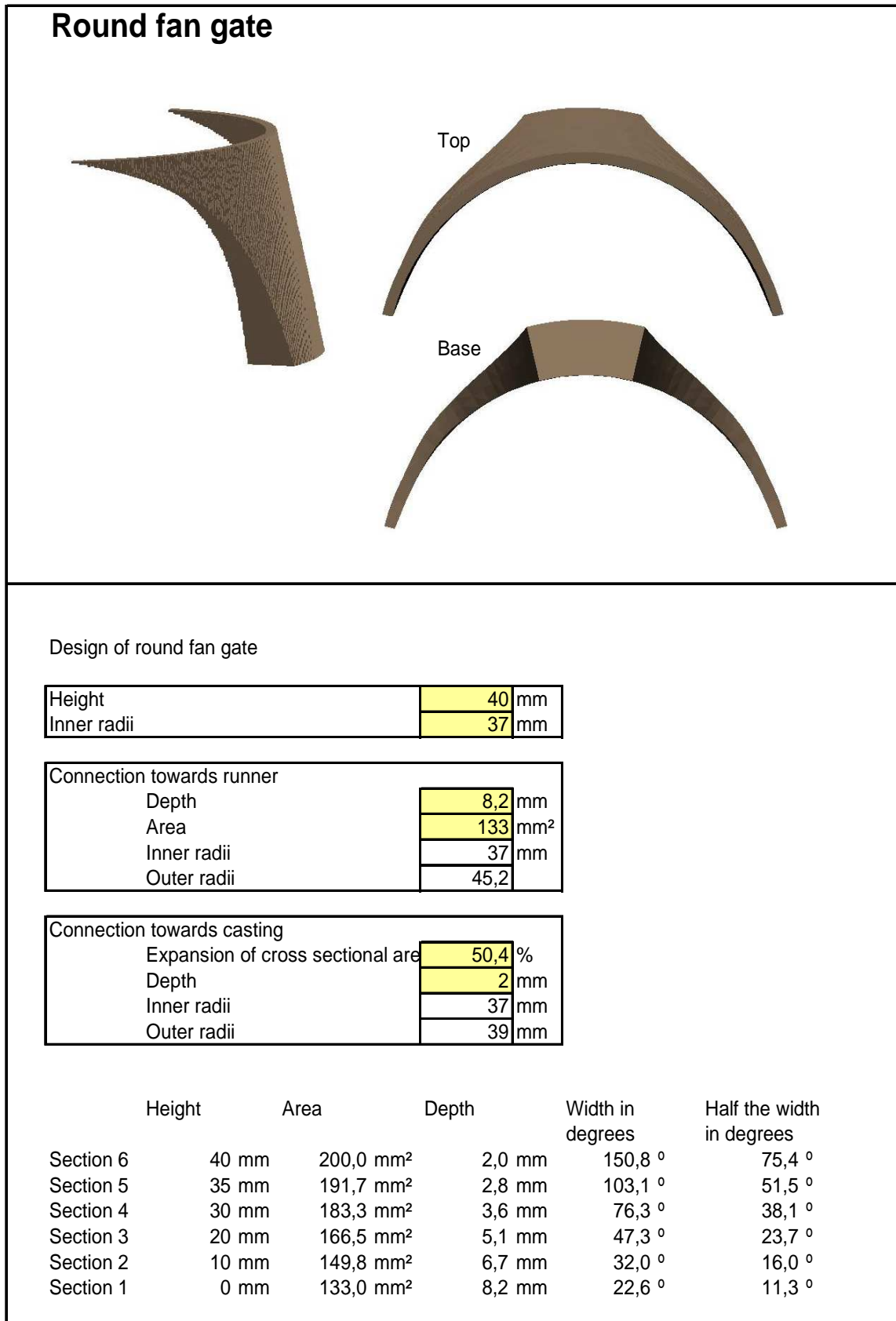


Figure 3-7 Sheet 3 – Fan gates. The sheet is used for designing a fan gate for special cases.





**Figure 3-8 Sheet 3 – Fan gates. This part of the sheet is used for designing a round fan gate. This type of fan gate can be useful for filling of a cylinder shaped casting.**

#### 3.2.4 Sheet 4 – Calculations

The fourth sheet is not necessary for the user to consider. This sheet is used for calculating all the dimensions, which is presented in the above mentioned sheets.

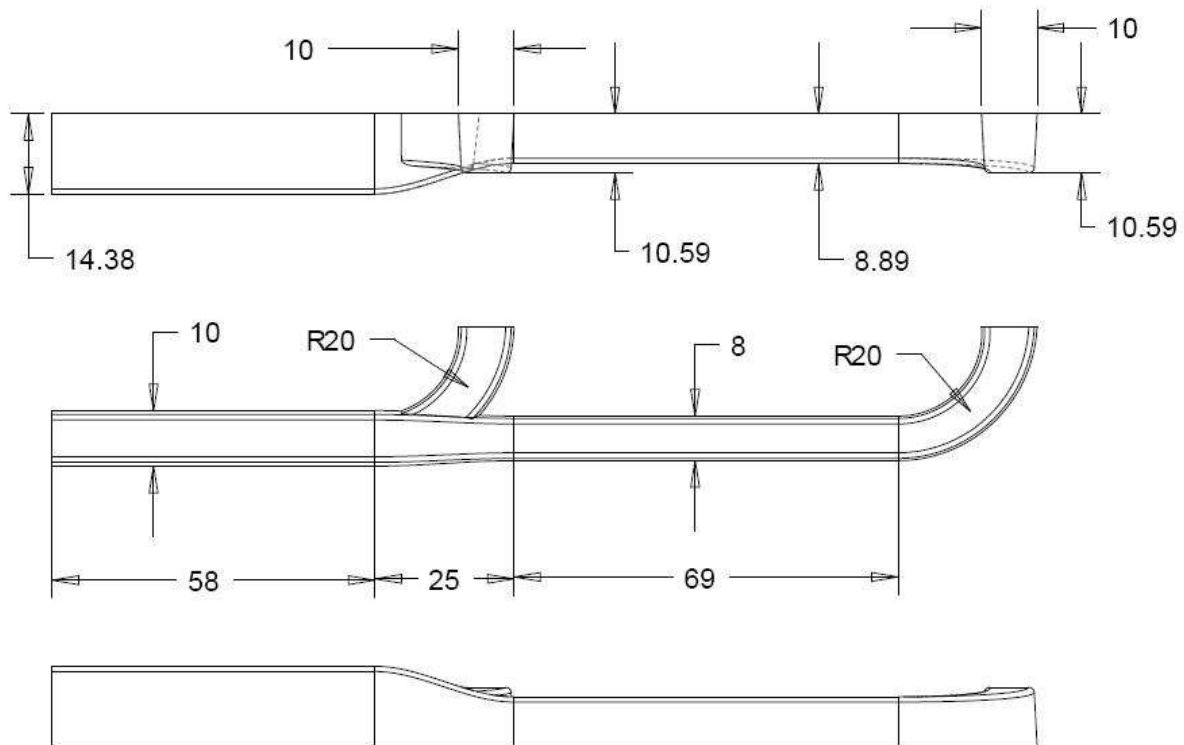
### 3.3 Designing layouts with more than one casting

To improve yield the gating system is as often as possible designed for more than one casting. An example of this was seen in the previous chapter ‘Theory in gating technology’ Figure 2-5. In this example three castings are placed on the pattern plate. As mentioned earlier the spreadsheet only calculates a gating system for one casting but it can of course also be used for designing of more complex gating systems with more castings.

When using the spreadsheet for designing a streamlined gating system like the one in Figure 2-5 with three castings it is necessary to start out by considering how to cast just one casting. This means that all data is typed in for a layout with only one casting. In this way the dimensions for fan gates and for the bends under the castings are found. These geometries are the same for all three castings. The cross-sectional areas for the horizontal runners needed for each casting is also used when designing the runners. To make sure that all castings are filled simultaneously it is very important that the cross-sectional areas in the horizontal runner everywhere in total are exactly the same. An example of this is seen in Figure 3-9. The melt will be coming from the left side in the figure. The two bends are the bends under the castings.

When the cross-sectional area in total everywhere is the same, it means that the cross-sectional area of the runner is gradually decreased to 50% when passing the bend under the first casting. Assuming the runner system so far is kept full this will make sure that half the melt is directed upwards to the first casting while the other half of the melt will continue through the runner to the last casting. The velocity of the melt continuing to the last casting will be higher than the velocity of the melt directed upwards to the first casting. This helps to make sure that the melt reaches the last

casting at approximately the same time as the melt for the first casting. In this way the castings will be filled simultaneously.



**Figure 3-9. Example of horizontal runner. The melt is meant to come from the left. Here the cross-sectional areas in total are the same at all positions.**

The horizontal runner for the third casting should have the same dimensions as the part of the runner to the right in Figure 3-9. In this way all three castings are going to be filled simultaneously.

Having designed the horizontal runner, the down runner and funnel are to be designed. This is done by using the spreadsheet once again. Now the data for casting all three castings are typed in. In this case it means for example tripling the weight of the casting or one can get the same results by reducing the filling time to only one third. To make sure the down runner is being designed correctly one can see if the cross sectional area of the end of the bend under the down runner is exactly three times the size found necessary for the same position after the first time the spreadsheet was

used. The bends below the down runner are designed in this case to tie the down runner and the horizontal runners together.

So by using the spreadsheet two times it is possible to find all dimensions for the streamlined gating system with three castings. In the example used here round fan gates are used. These are of course designed using 'Sheet 3 – Fan gates'.

#### **3.4 Standard geometries for the pattern plate**

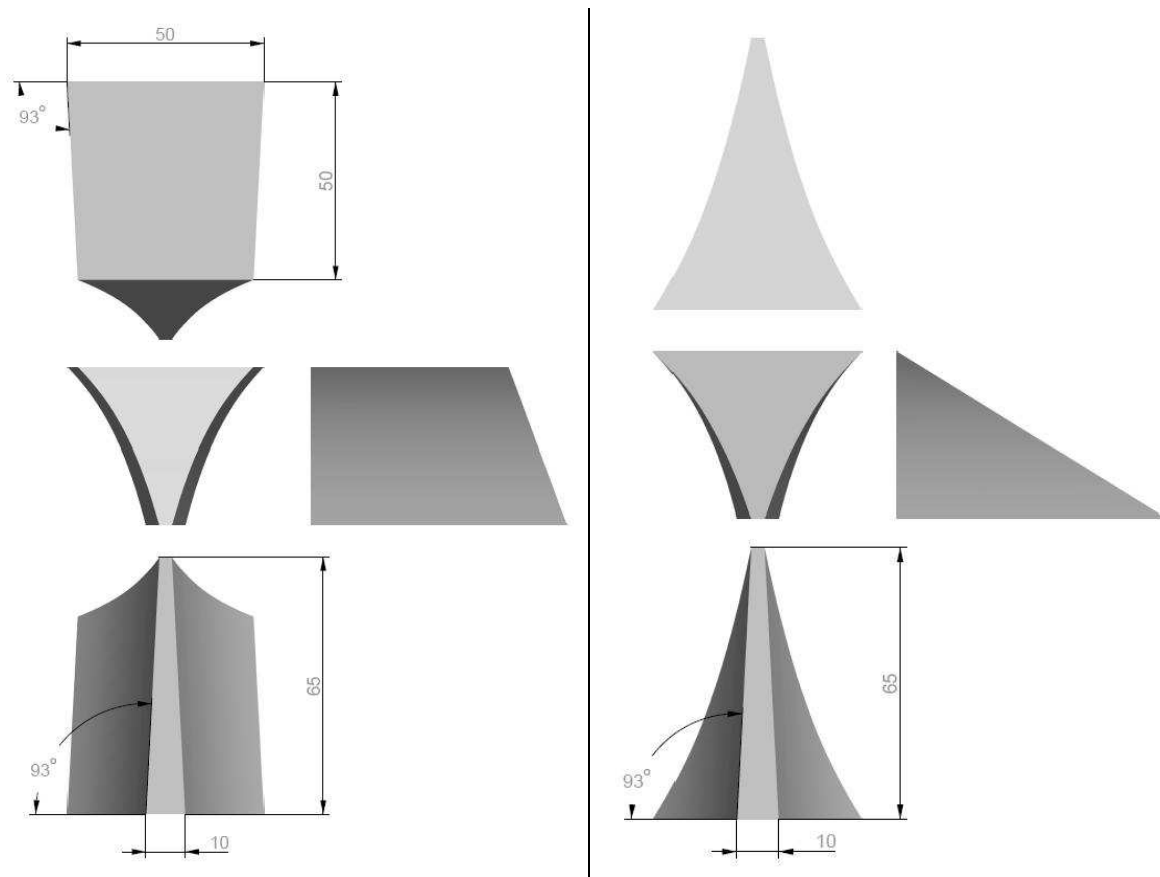
The pattern workshop in the foundry is often a very busy place. Every time new castings are to be produced the pattern workshop mounts the geometry on the pattern plate together with the patterns for the feeders and for the gating system. For the traditional layout it is very common to have a set of standard geometries for runners. Often these standard runners are named with a number. This system makes it very easy for the designer of the gating system to make drawings for the pattern workshop, and at the same time it is very fast for the pattern workshop to find the correct geometry to mount on the pattern plate. Of course it is not possible only to use standard geometries therefore some machining is still necessary for example to achieve the correct filling time.

In this section it is described how one can use standard geometries to design streamlined gating systems. To give an idea of how to design a set of standard geometries an example is given below. This example shows a set of standard geometries that can be used in for example an iron foundry using vertically parted moulds. As previously described most foundries have a pouring cup specially designed for their pouring device. Therefore no details will be given here on how to design the pouring cup – even though, as mentioned earlier, it may be economically beneficial to have a closer look at the design of the pouring cup after having implemented the use of streamlined gating systems.

To make a set of standard geometries it is necessary to decide on a standard width for the gating system. For cast iron it is recommended to keep the width no wider than 10mm if possible. Therefore a standard width of 10mm will be used for this example. Another decision is the draft angle. For green sand moulds normally a draft angle of three degrees is used. The basic idea behind all the standard geometries is that it should only be necessary to machine the geometries on one side to use them on the pattern plate. Unfortunately it is not really possible to design a standard geometry for fan gates. The reason is that there are too many variables in the design of a fan gate. First of all the width and depth of the connection to the casting depends on the geometry of the casting. But also the connection to the runner varies. Finally the height of the fan gate may also vary depending also on the space available on the pattern plate.

#### **3.4.1 The funnel**

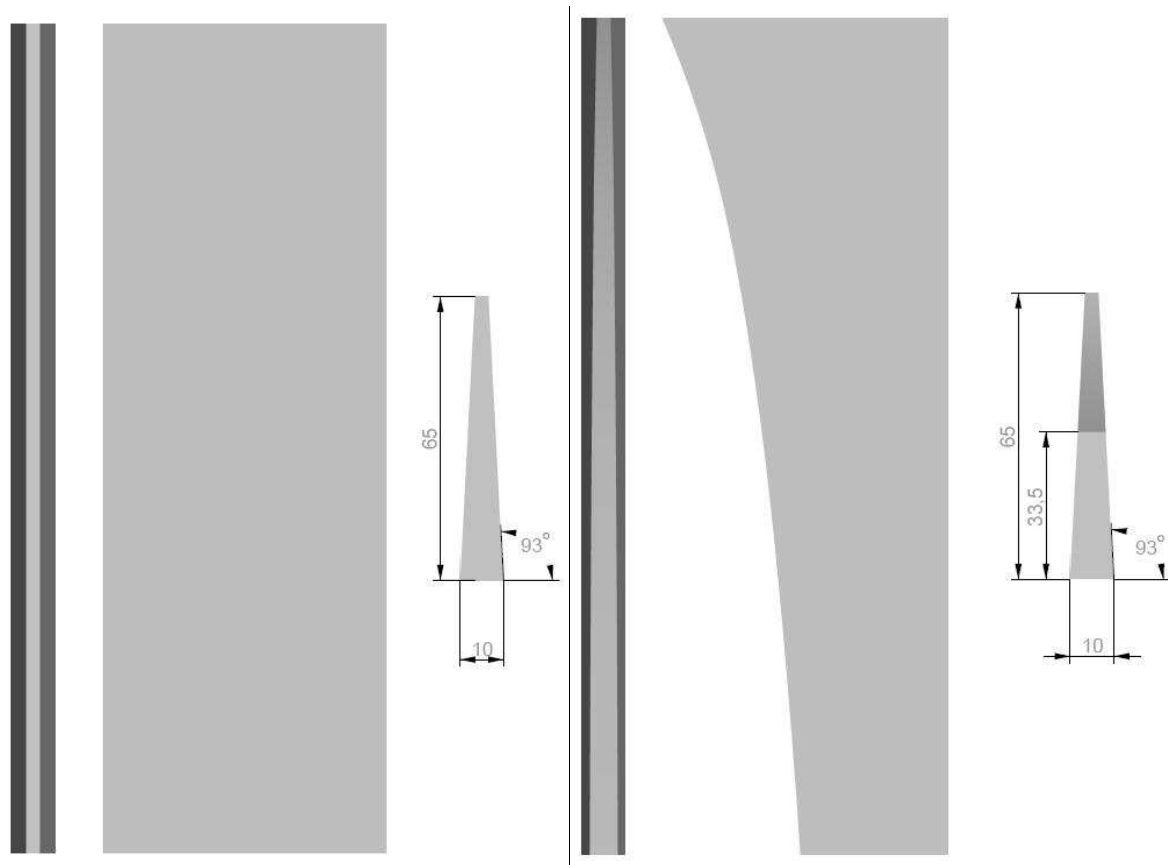
The first standard geometry needed is the funnel. When designing the top of the funnel it is necessary to know the geometry of the base of the pouring cup. In the case a filter is positioned as the base of the pouring cup the geometry of the outlet of the filter is necessary to know. Finally the height of the funnel needs to be decided. The final standard geometry for the funnel could then look like the left side in Figure 3-10. In this case the top geometry is kept constant at all times and the depth of the base geometry is modified according to the depth of the top of the down runner. Also as described earlier if a maximum runner width of 10mm is kept and a draft angle is needed, it also means that there is a limit to the size of the cross sectional area. This means that it might be necessary to have half the down runner on the one pattern plate and half on the other. In this case it is also necessary to have the funnel on both pattern plates but in a way so that a pouring cup is not needed on both plates since this would increase the pouring weight considerably. The right side of Figure 3-10 shows the standard geometry to be used in this case together with the funnel in the left side of Figure 3-10.



**Figure 3-10 Standard geometry for the funnel. To the left is the standard geometry for under the pouring cup. To the right is the standard geometry for the other pattern plate.**

#### 3.4.2 The down runner

To design a standard geometry for the down runner the geometry of the base cross-section of the funnel is used. This results in the very simple geometry which is shown to the left in Figure 3-11. This standard geometry can be used for all runners both vertically and horizontally. Of course this standard geometry should be made sufficiently long for all purposes. To the right in Figure 3-11 an example of a down runner is seen. This example shows how a down runner could look if it was made from the standard geometry. As can be seen only one side of the standard geometry needs machining.



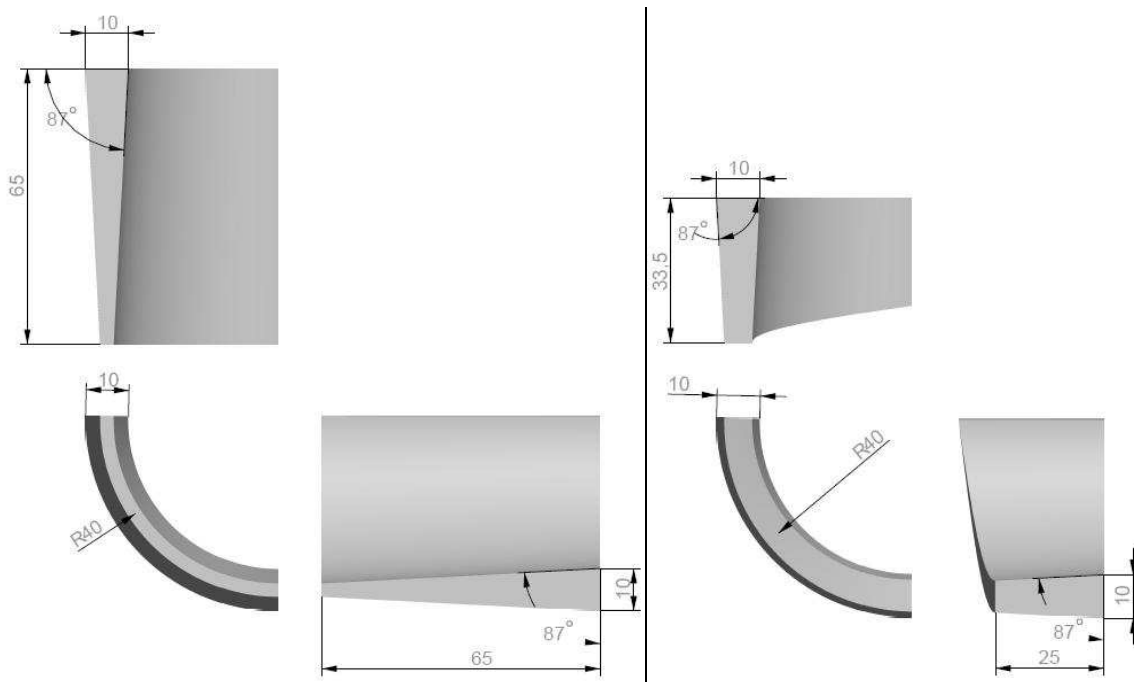
**Figure 3-11 To the left: Standard geometry for down runner and horizontal runner. To the right an example of a finished down runner if it was made from the standard geometry to the left.**

#### 3.4.3 The bends

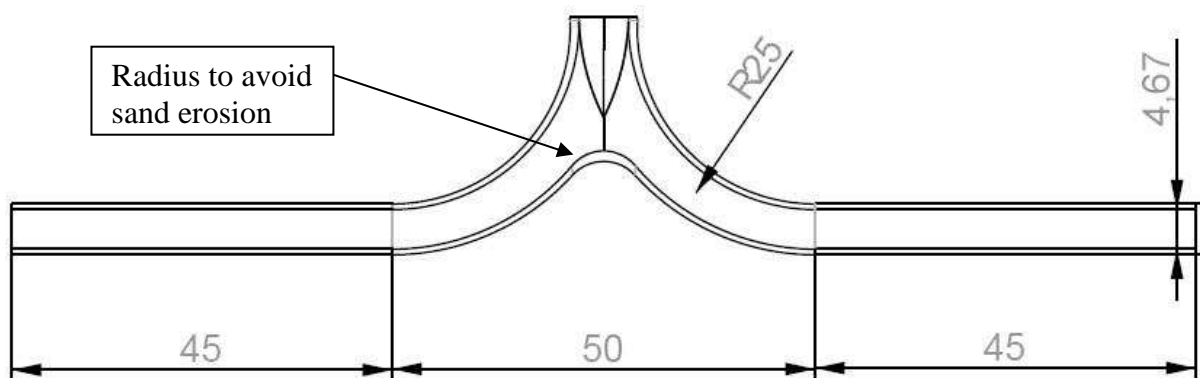
For making the bends yet another standard geometry is needed. This can be seen to the left in Figure 3-12. To the right in Figure 3-12 an example of the bend after machining is seen. More bends all with different radius can be very useful to have to choose from when designing the gating system. These standard geometries can of course be used both under the down runner and under the casting.

The geometry shown here can also be used in the case when it is necessary to split the melt to either side at the base of the down runner. This is done by simply combining two of the standard geometries. An example of this is seen in Figure 3-13. The figure also shows that a small radius is put in between the two bends to avoid sand erosion. This radius should of course be as little as possible but exactly how small this radius can be depends on the sand quality in the individual foundry and the height of the

mould, but a radius of no more than 5mm has proven to be large enough in most green sand moulds. It is important when placing a radius like that to remember that by doing this the cross-sectional area is increased which can lead to small air entrapments during filling in the inside of the two bends. It is possible to compensate for this by narrowing the bends a little in this area.



**Figure 3-12** To the left: Standard geometry for the bends. The example shown here has a radius of 40mm. To have more options to choose from geometries with different radius can be made. To the right: Bend after machining.



**Figure 3-13** The figure shows an example of how the combination of to standard geometries for bends can be used for guiding the melt to either side under the down runner. Between the two bends a small radius is put to avoid sand erosion.



#### **3.4.4 Using the standard geometries in the design of the layout**

In many foundries it is common practise when designing the casting layout to start out with a drawing of the pattern plate scaled 1:1. Then drawings of the castings are printed, cut out, and placed also on the drawing of the pattern plate to see exactly how many castings there is room for on the pattern plate. When the castings are positioned the gating system is designed. In this way it is easy and not very time consuming to get a good overview of how the layout should be made.

When standard geometries are as presented in the above it is easy to have these geometries printed and used in combination with the printed castings also. In this way it is easy to try for example different bends and find out exactly how sharp the bends should be. The data from this work can then be used in the spreadsheet to get all the final dimensions.

## 4 Simulations

The trend in the castings is that the complexity of the geometry and requirements in mechanical properties are increasing. Due to this development the need for computer simulations to design and optimize the part to be cast has increased. At the same time the need for computer simulations to design feeders and the gating system has also increased.

### 4.1 Integrated modelling

The way to achieve the most optimal solution is to use integrated modelling. The idea behind integrated modelling is to use computer simulations to analyse all parts of the process chain as well as how the part performs in use. The process in integrated modelling is seen schematically in Figure 4-1.

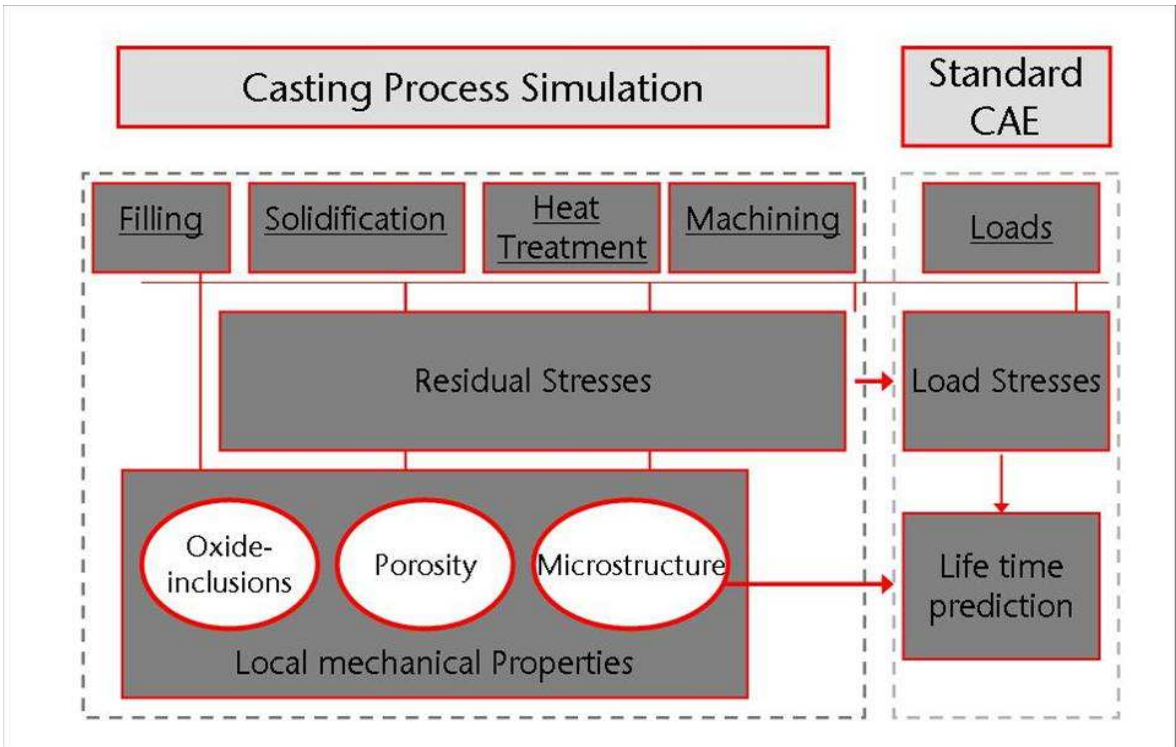


Figure 4-1 Schematic illustration of integrated modelling. [Ref. 4-1]

To use integrated modelling for a part to be cast it is necessary first to simulate mould filling. The result from here is then used as a basis for the simulation of the

solidification simulation. The resulting residual stresses are then used for simulating the heat treatment which again is used for simulating the machining of the part. Finally these results are used for simulating the load stresses of the part in use.

### 4.2 Design optimization of the valve housing

In the case study of the valve housing simulations have been done to try to optimize the part to make it easier and cheaper to cast. To do all of the simulations in integrated modelling of course take some time and the full optimization process regarding the case study has not been done in this project.

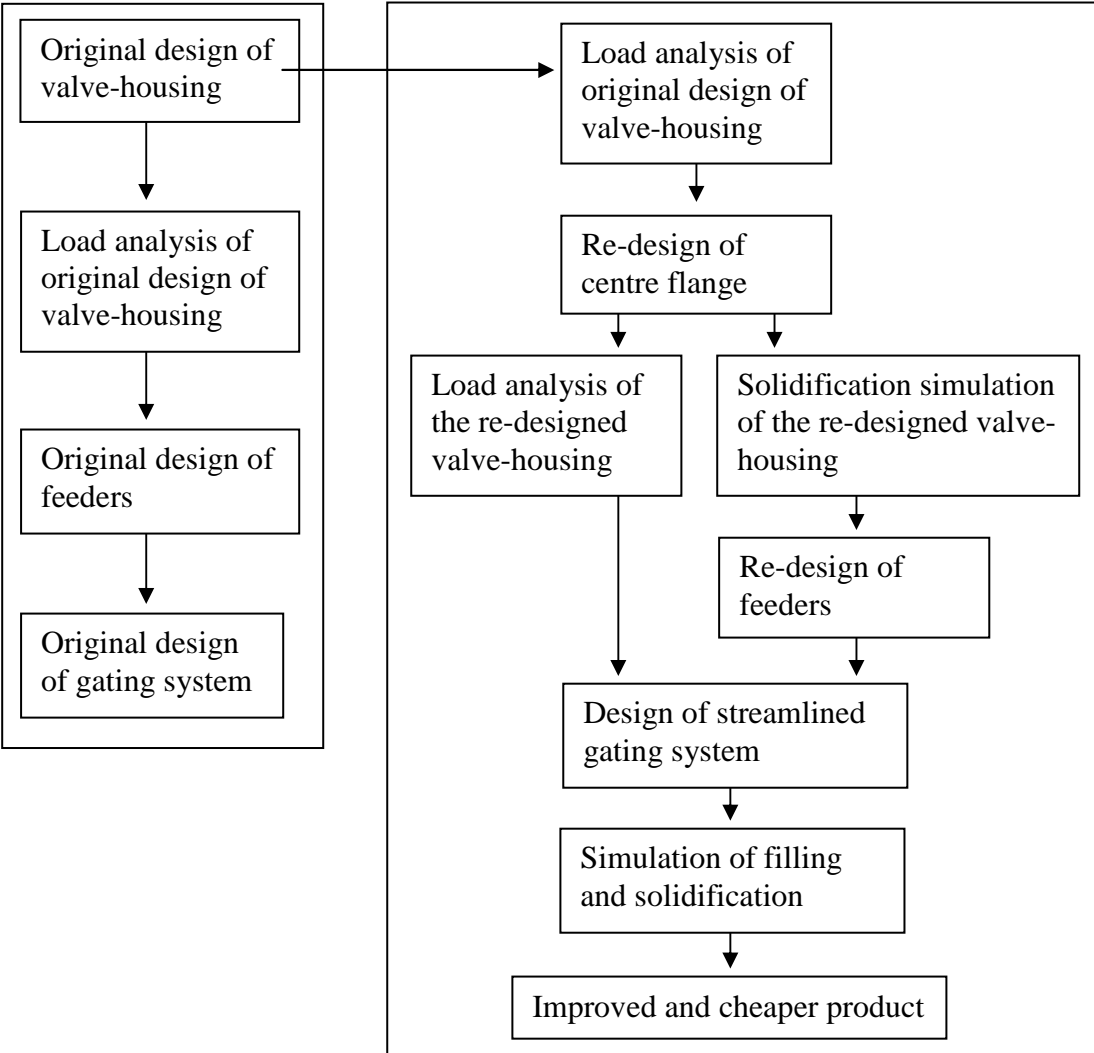
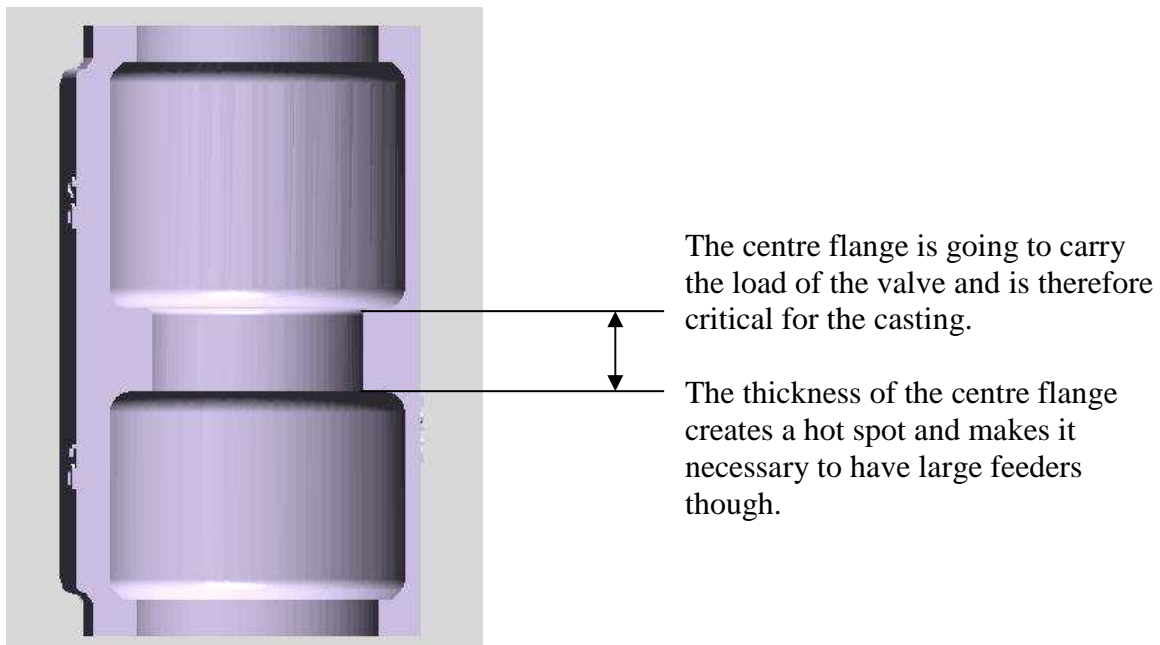


Figure 4-2 Schematically representation of the optimization process. To the left: the process leading to the traditional layout. To the right: the process leading to the streamlined layout.

The valve-housing used as case study in the project has however been analyzed. The process in the analysis and optimization is seen schematically in Figure 4-2 and a closer description is given in the following.

In the original design of the valve housing only considerations regarding the mechanical properties were taken. Simulations were done to see if the part as originally designed had the mechanical properties for the purpose. The result of these simulations showed that with an assumption of uniform material properties the mechanical properties lived up to the specifications. [Ref. 4-2] Since there is no real requirement regarding the weight of the part in use no optimization based on the results from the simulations were done.

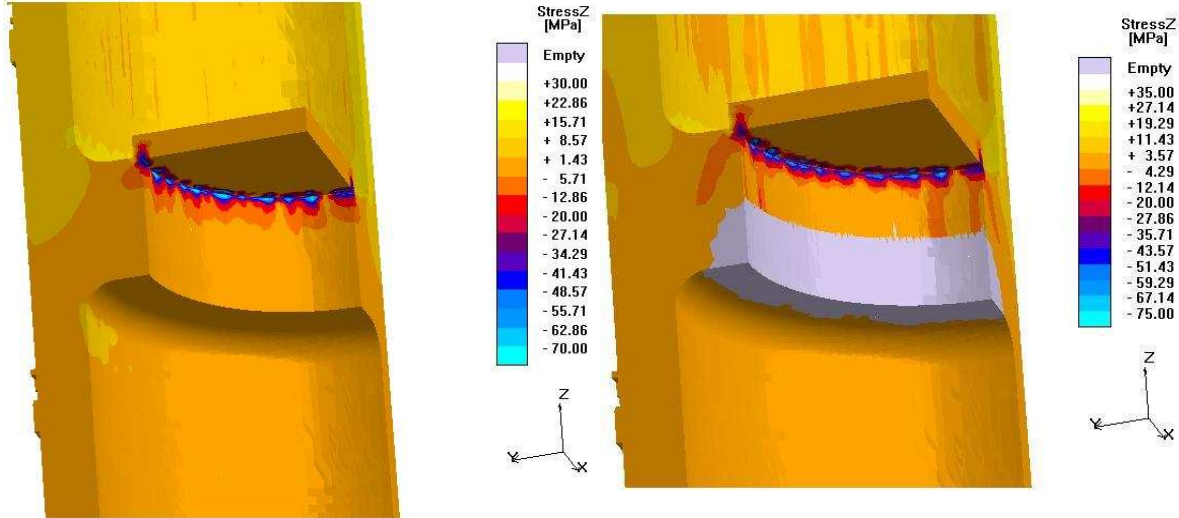
A three-dimensional representation of the valve housing cut through vertically is seen in Figure 4-3. It is seen that the centre flange is very thick compared to the wall thickness of the rest of the housing.



**Figure 4-3 Three dimensional representation of the valve housing cut through. The possibility of reducing the thickness of the centre flange is considered.**

In use the centre flange is going to carry the load of the valve and therefore porosities in this area should be avoided. However the large difference in modulus between the wall of the valve housing and centre flange creates a hot spot in which the centre flange will work as a feeder for the wall. This again increases the need for having a feeder for the centre flange. To decrease this need for feeding stress-simulations were done to examine how much the load in the worst possible case will affect the centre flange.

The valve housing is for a balancing valve. This means that the worst case scenario is if the valve completely blocks the flow of fluid through, and the entire maximum pressure is exerted on the closed valve. To the left in Figure 4-4 results from these stress simulations are seen. In the pictures only one quarter of the centre flange is seen and the valve is represented by a plate, also seen in the picture.



**Figure 4-4 Results from the stress simulations. To the left: the original flange. To the right: the new flange. The gray area represents the part of the flange removed. [Ref. 4-3]**

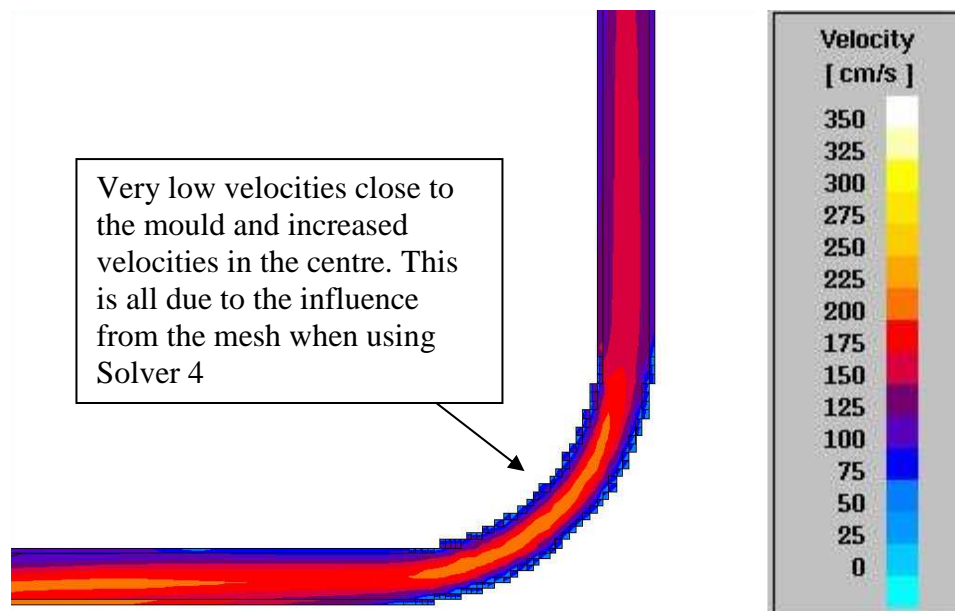
The conclusion of these simulations was that the centre flange in the original design was heavily over-dimensioned and the flange can with no problems be reduced to only half the size. [Ref. 4-3] This conclusion was used for the design of the streamlined gating system as seen in the chapter ‘Theory in gating technology’. The reduction in size of the flange means that the size of the feeders could be reduced and the position

of the feeders changed for the streamlined gating system. The diameters of the feeders are kept constant but the height is reduced. It has not been investigated if the flange could be reduced even more but results indicate that it could be an option.

### 4.3 Setting up filling simulations

#### 4.3.1 The Solver

All simulations in this project have been done using the commercial software Magmasoft. There are a few critical parameters to be more aware of when setting up filling simulations for streamlined gating systems in Magmasoft. The first and most important is that to achieve the most reliable result simulating streamlined gating systems having a lot of smooth bends it is critical to use Solver 5. The reason is that using Solver 4 results in the problem seen in Figure 4-5. It is clearly seen how the mesh influences the flow pattern. The effect from the stairs in the mesh means effectively a narrowing of the runner system in the bend. The velocities are very low close to the mould but much higher in the centre.



**Figure 4-5 Velocities in a bend under a down runner using solver 4. The Influence of the mesh on the flow path in the bend is clearly seen.**

The reason is that Solver 4 sees a volume as either mould or cavity. Using solver 5 means an elimination of problems like these. The main reason for this is that Solver 5 uses so called porosity factors. This means that Magmasoft for the volumes that supposedly represent both mould and cavity for each side of each volume determines the percentage of area that is mould and the percentage that is cavity. In this way Solver 5 can see a volume as both mould and cavity and hence no longer as only the one. [Ref. 4-4]. For a deeper explanation of how Solver 5 works the Magmasoft Version 4.4 Online Help function is referred to.

Using Solver 5 is more time consuming than Solver 4. However using Solver 5 means that a much coarser mesh can be used again reducing the calculation time. Experience shows using solver 5 and a more coarse mesh do not increase the calculation time. The results achieved from using Solver 5 are more correct though than results from using Solver 4.

4.3.2 Filling definitions

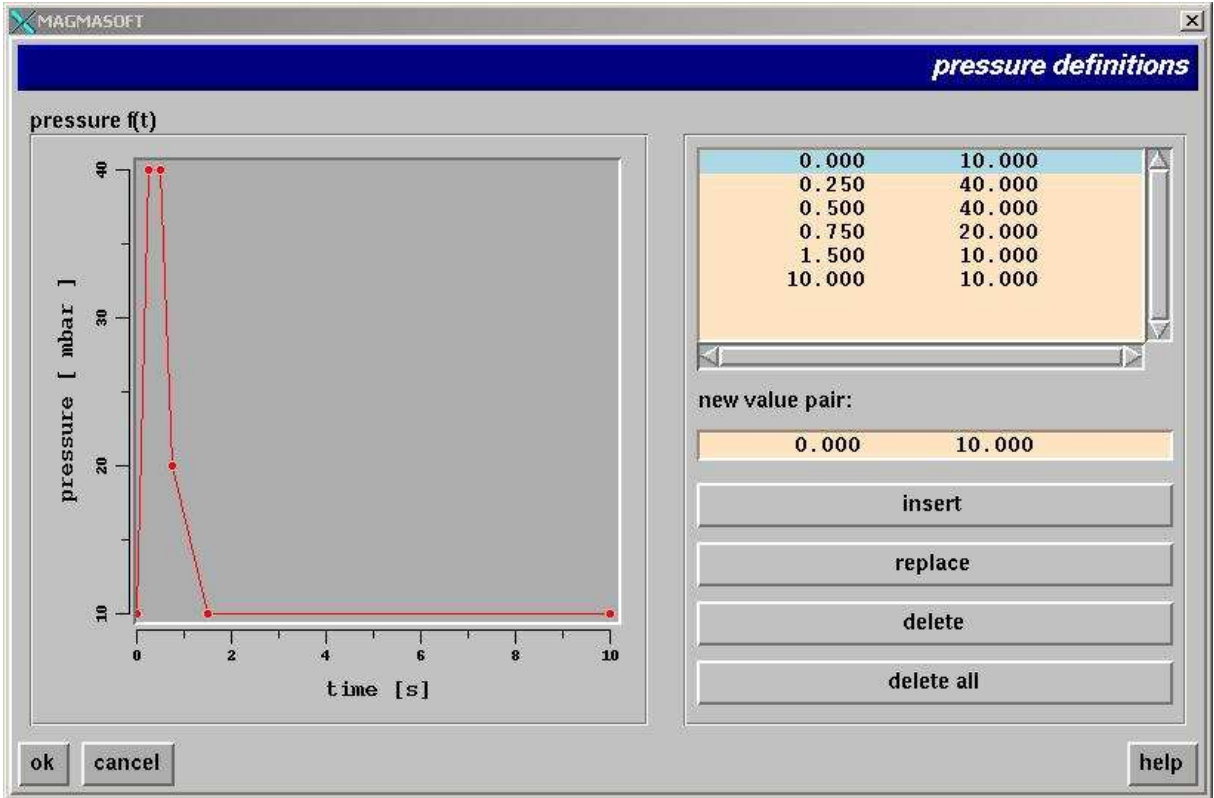


Figure 4-6 Pressure definitions used for the mould filling simulations in this project.

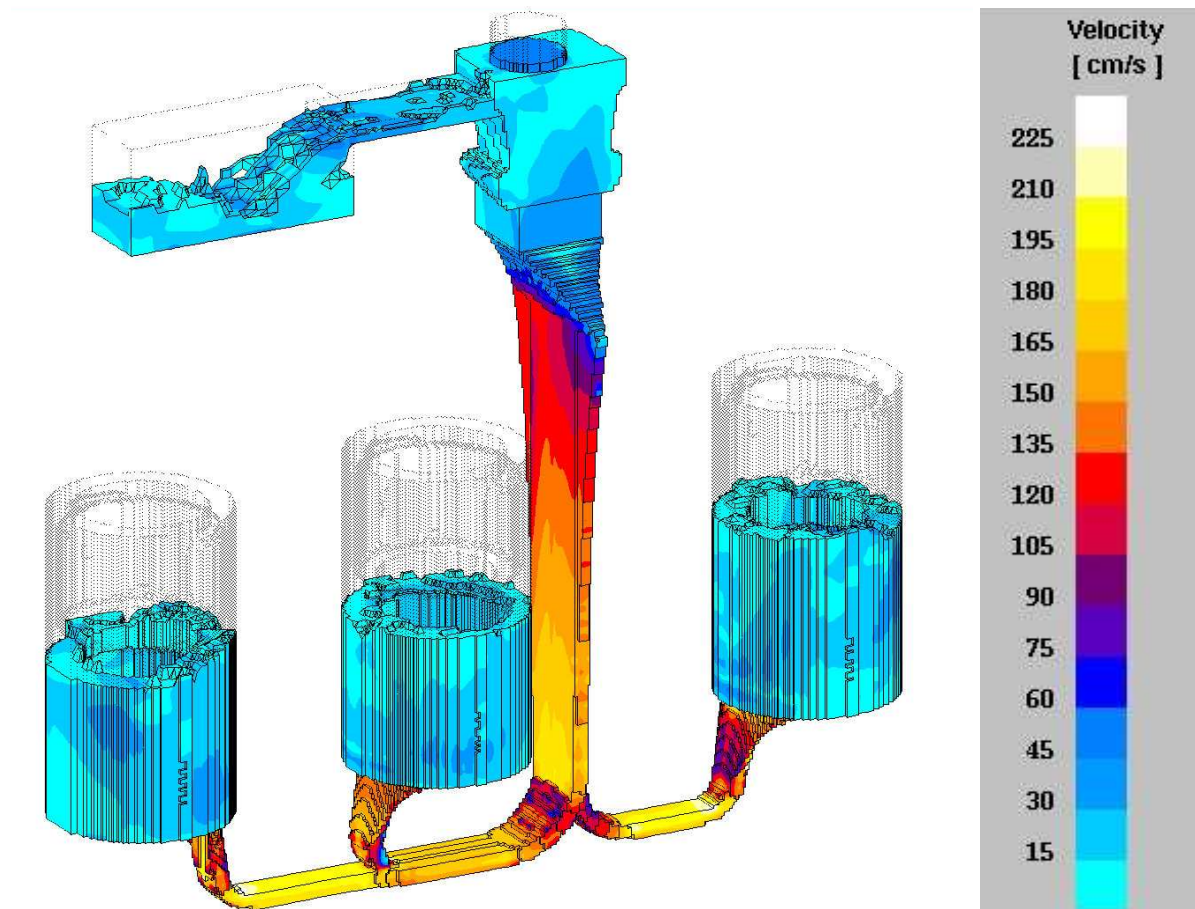
When setting the filling definitions there are three different boundary conditions that can be imposed. These are Time, Pouring rate, and Pressure. When simulating mould-filling determined by gravity either Pouring rate or Pressure should be used. In this way it is possible to describe approximately the conditions seen in reality. In all the simulations in this project a pressure definition has been used. The pressure curve used is seen in Figure 4-6.

### 4.3.3 Overflow

It is of great importance when doing filling simulations that the pouring cup is the very last part to be filled. The reason is that Magmasoft can not simulate what happens if the melt is poured too fast and the melt then starts flowing over the top of the mould as it would in reality. Instead Magmasoft simply applies the full pressure on the melt at the time the pouring cup is full leading to an artificial pressure wave. This will result in severe turbulence not to be expected in reality. There is more than one way of avoiding this. First of all the simulations can be trimmed to avoid the problem for example by changing the filling definitions or by reducing the diameter of the inlet in the pre-processor. Doing this can be very time consuming and difficult and if for example the inlet becomes too small it might not be as good a representation of the reality as it could be. In general the area of the inlet should be slightly larger than the cross sectional area of the top of the down runner. But even having this guideline it can still be difficult to avoid that the pouring cup is filled prematurely.

Instead of using time on fine tuning the simulation it can be easier to simply put in an overflow in the pre-processor. An example of this is seen in Figure 4-7. The idea behind the over flow is to prevent the pouring cup from being filled too early by simply adding a volume that could be seen as an expansion of the pouring cup. The overflow is added without interfering with the flow pattern in the pouring cup. The overflow can be assigned its own material number making it possible to give the overflow a very coarse mesh. In this way the calculation time is not prolonged too much and it is also possible to leave out the overflow in the presentation of the results.



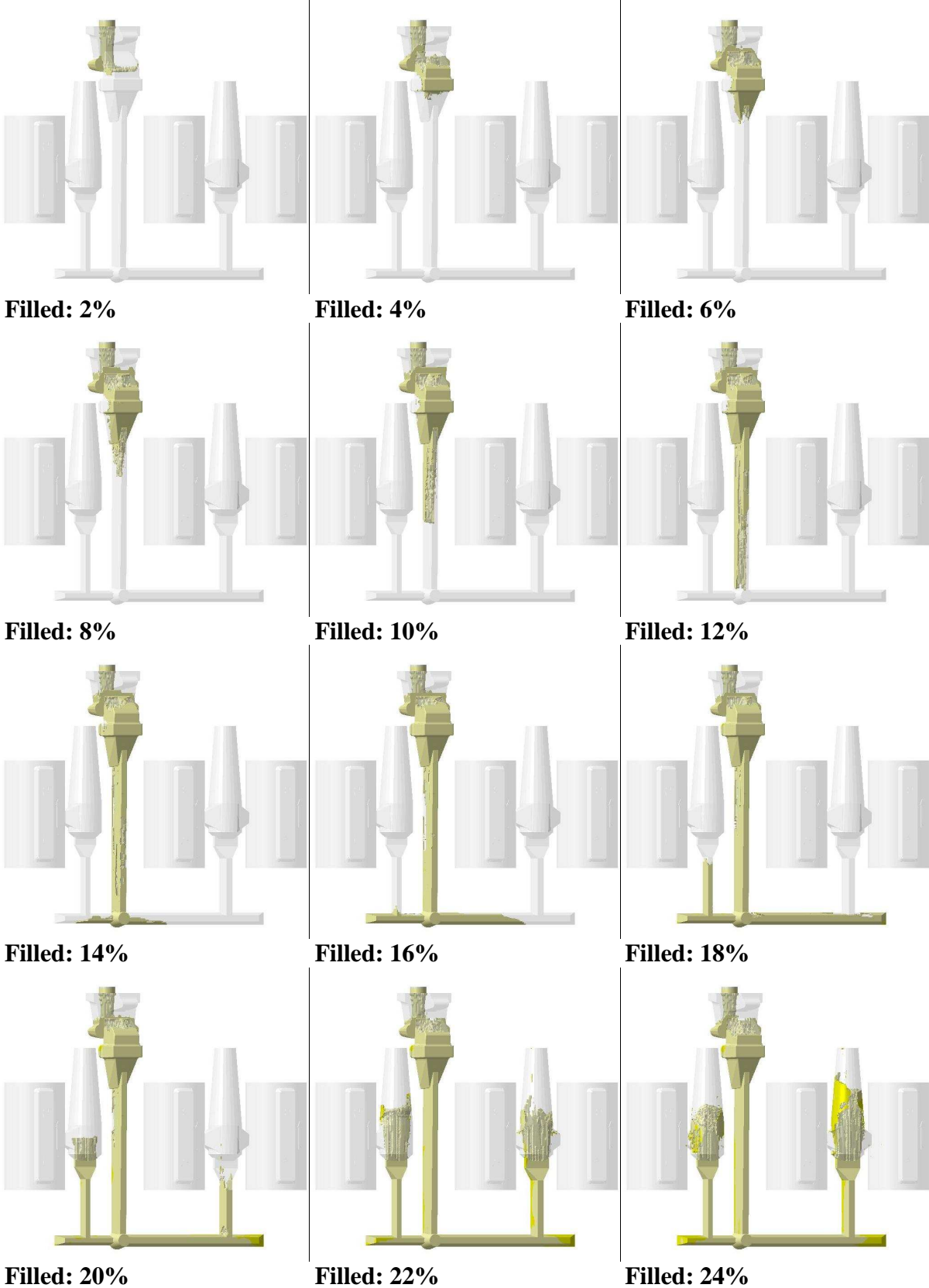


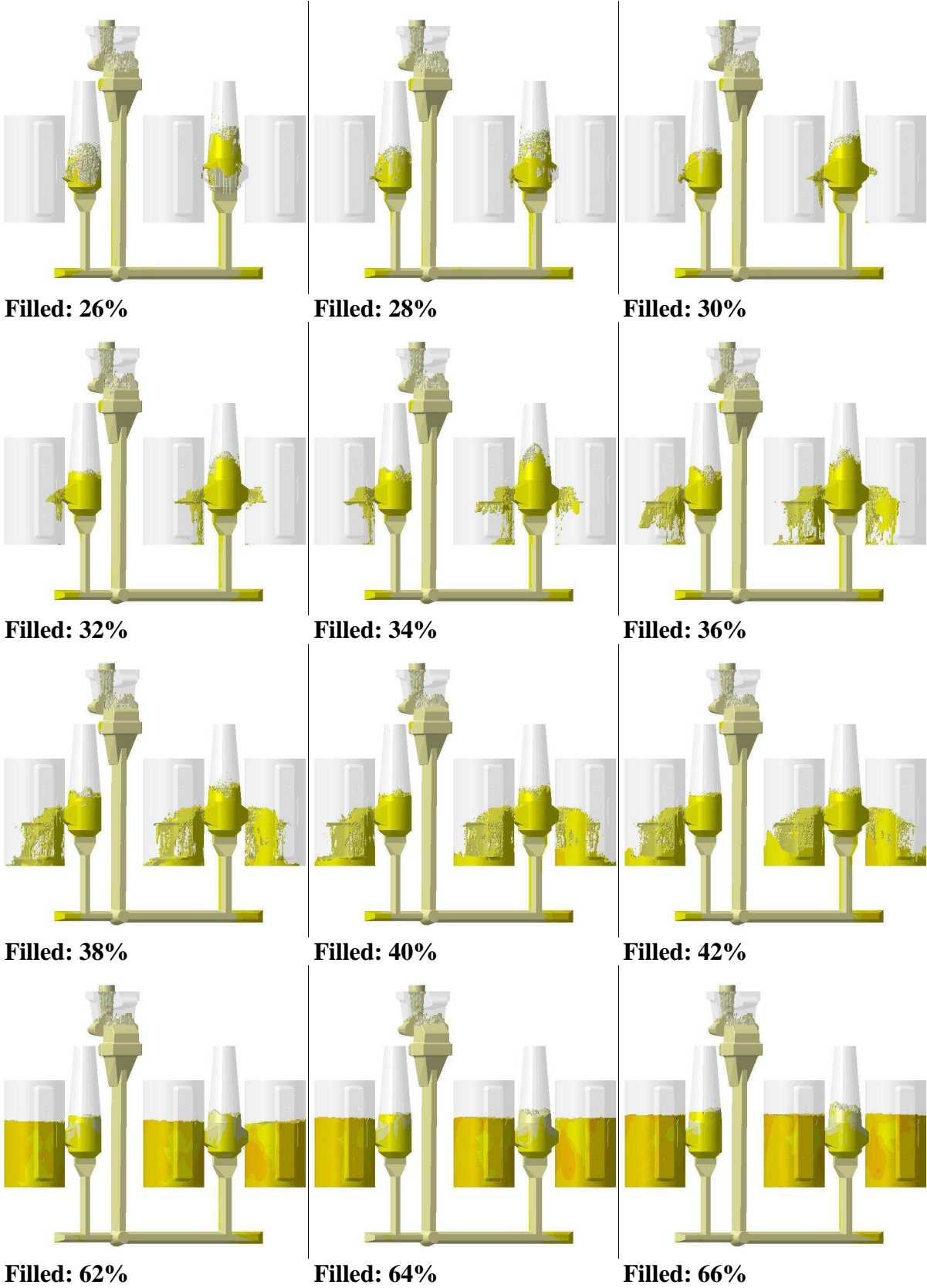
**Figure 4-7** The picture shows the principle in having an over flow. The over flow prevents the pressure wave that occurs if the pouring cup is filled prematurely.

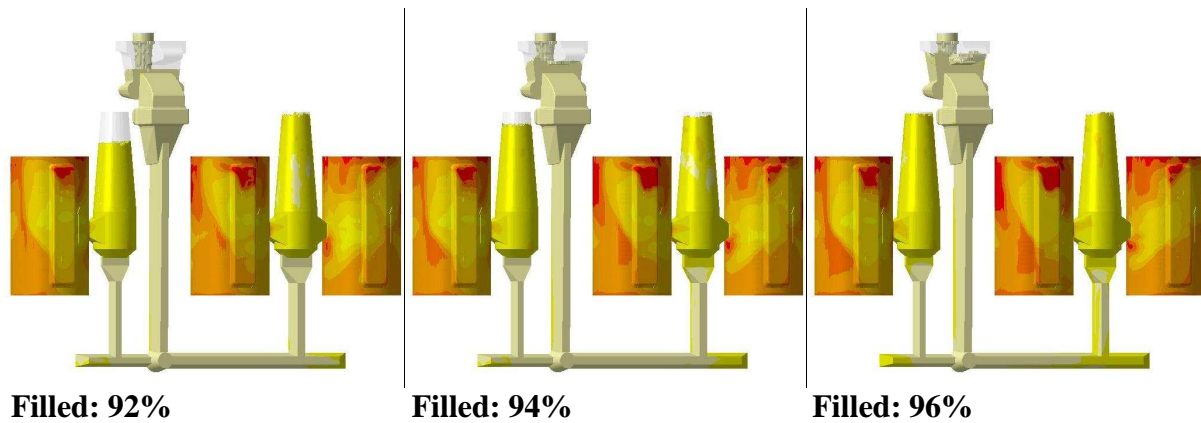
#### 4.4 Filling simulations and comparison of the two layouts

Simulations have been done for both the traditional and the streamlined gating systems described in ‘Theory in gating technology’. Selected parts of the results from these simulations are presented in the following. The full sets of results are found in Appendix 1 – 14.1.2 and 14.1.3. Comparing the results from the traditional and the streamlined layout it is important to notice that the volumes of the castings, feeders and gating systems are not the same. This means that 6% filled in the traditional layout is not the same as 6% filled in the streamlined layout, so the percentages filled can not be compared directly. The temperature scale is seen in Appendix 1 – 14.1.1.

The traditional gating system







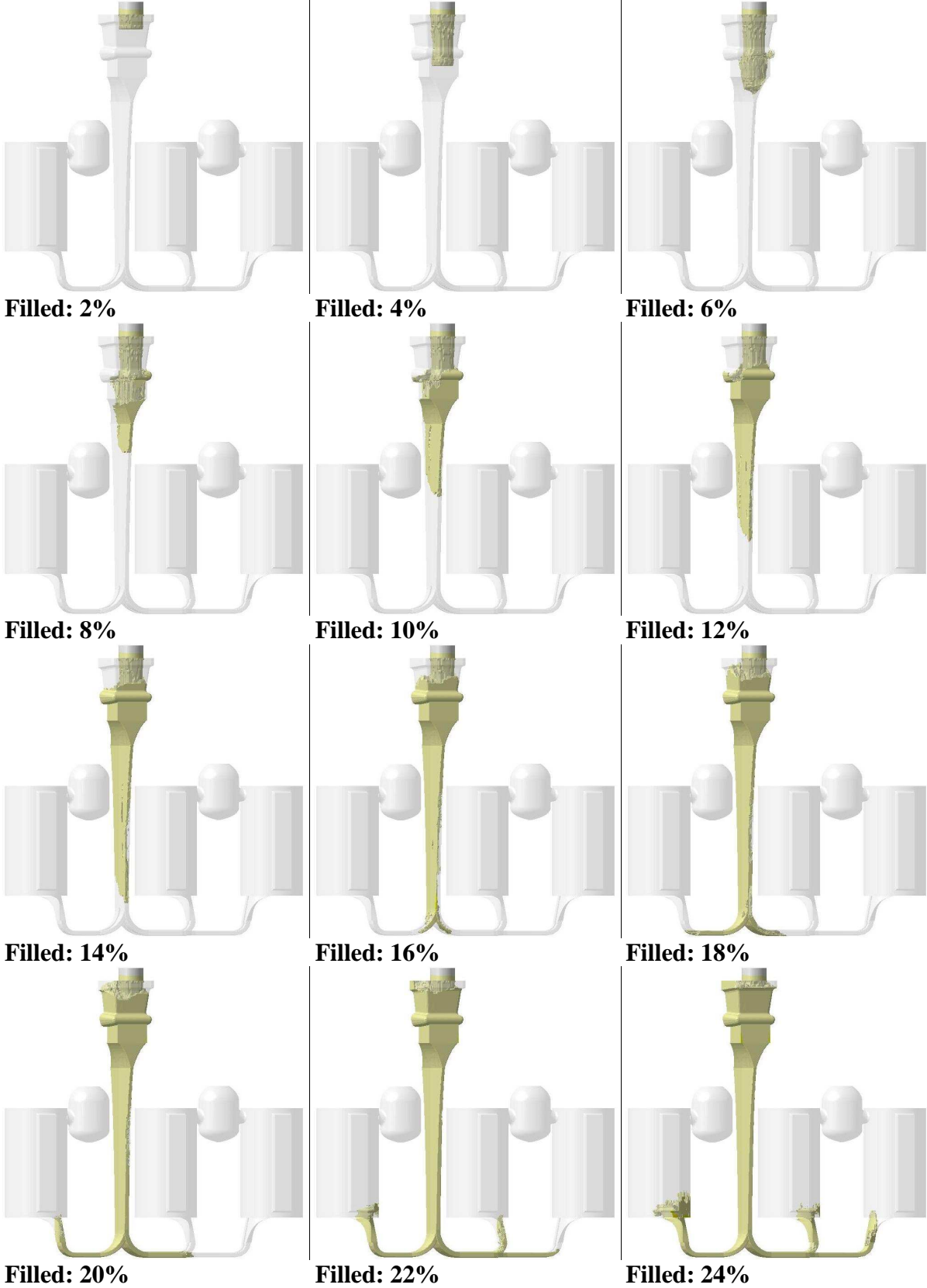
**Figure 4-8 Simulation results – The traditional layout**

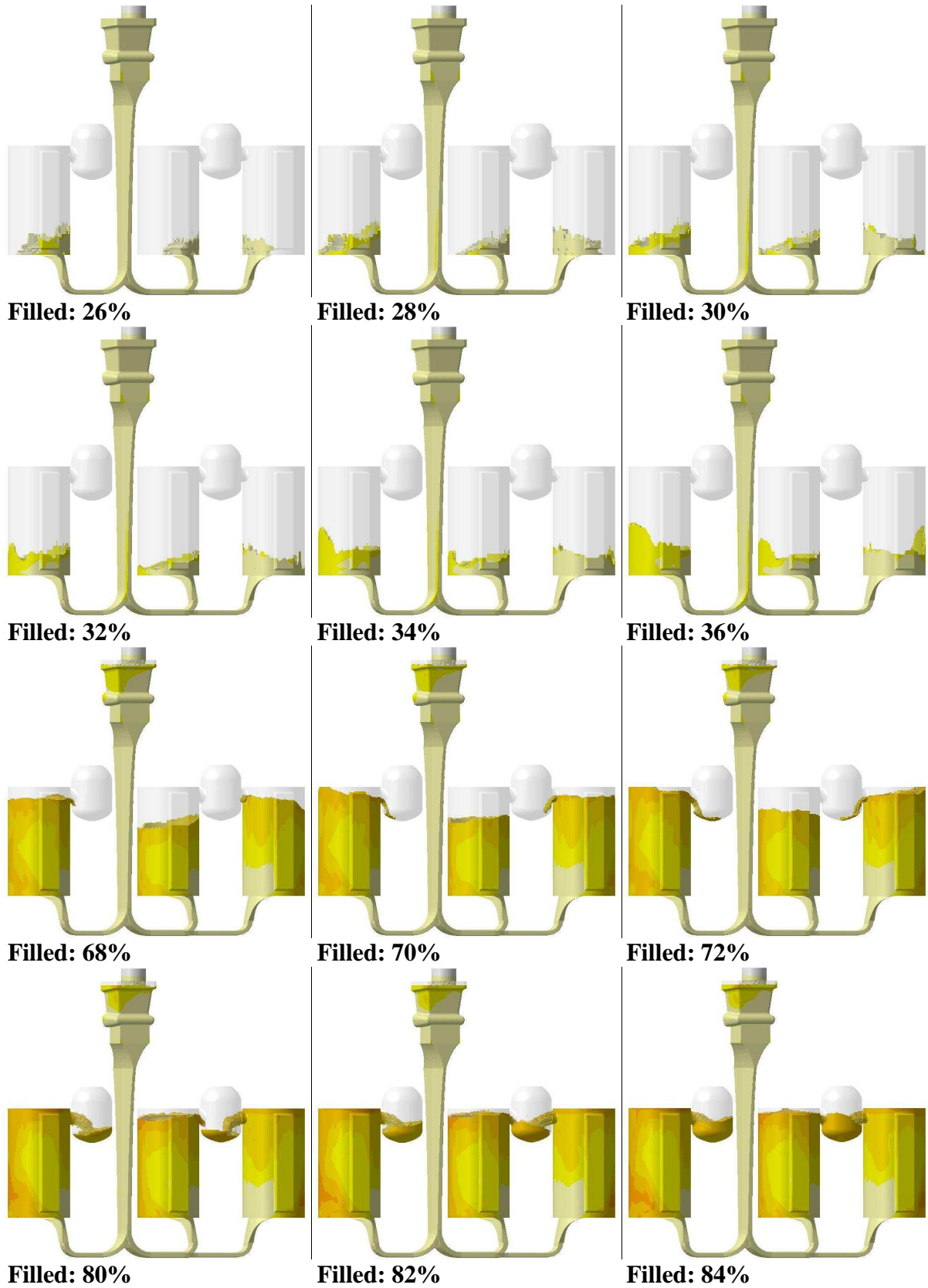
The results from the simulation reveal many problems in the flow pattern. First of all clearly it is not possible to keep the down runner full. The down runner backfills and is actually not full till 22% filled. At approximately this time two jets are also seen inside the feeders. These jets could be seen as a result of the disappearance of the vena contracta in the down runner, but also as a consequence of the dead ends in the horizontal runner are filled. At 30% filled the jets have calmed down and the melt starts to flow into the castings.

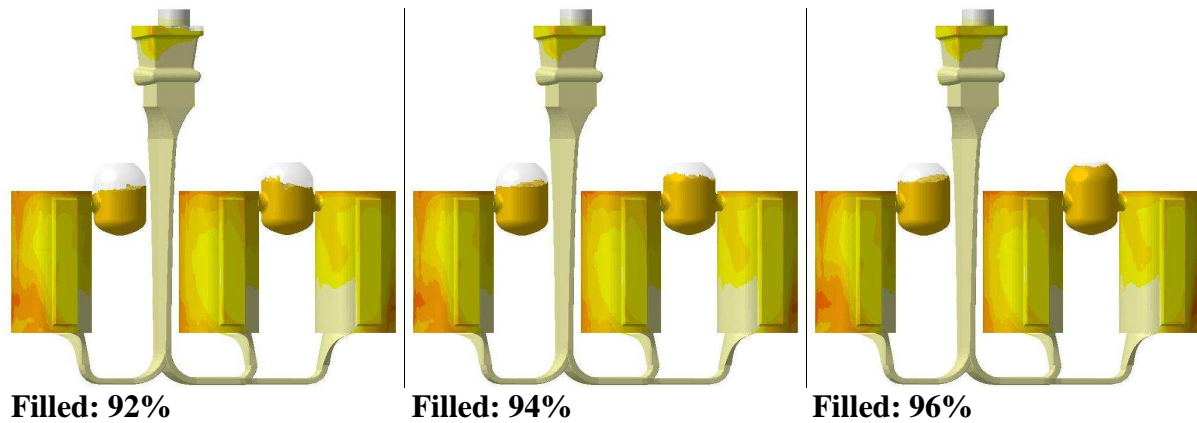
The feeder necks are attached to the centre flange which means the first melt that enters the castings will drop half the height of the casting. This will again cause turbulence and air entrapment. Normally for ductile iron a drop of this height will not be considered a problem. Once the level of melt reaches the height of the feeder necks the remaining part of the filling is very calm.

The flow pattern during the filling leaves some very distinct temperature gradients which will cause non-uniform material properties in the casting. Normally to achieve better and uniform mechanical properties the castings would be heat treated.

The streamlined gating system





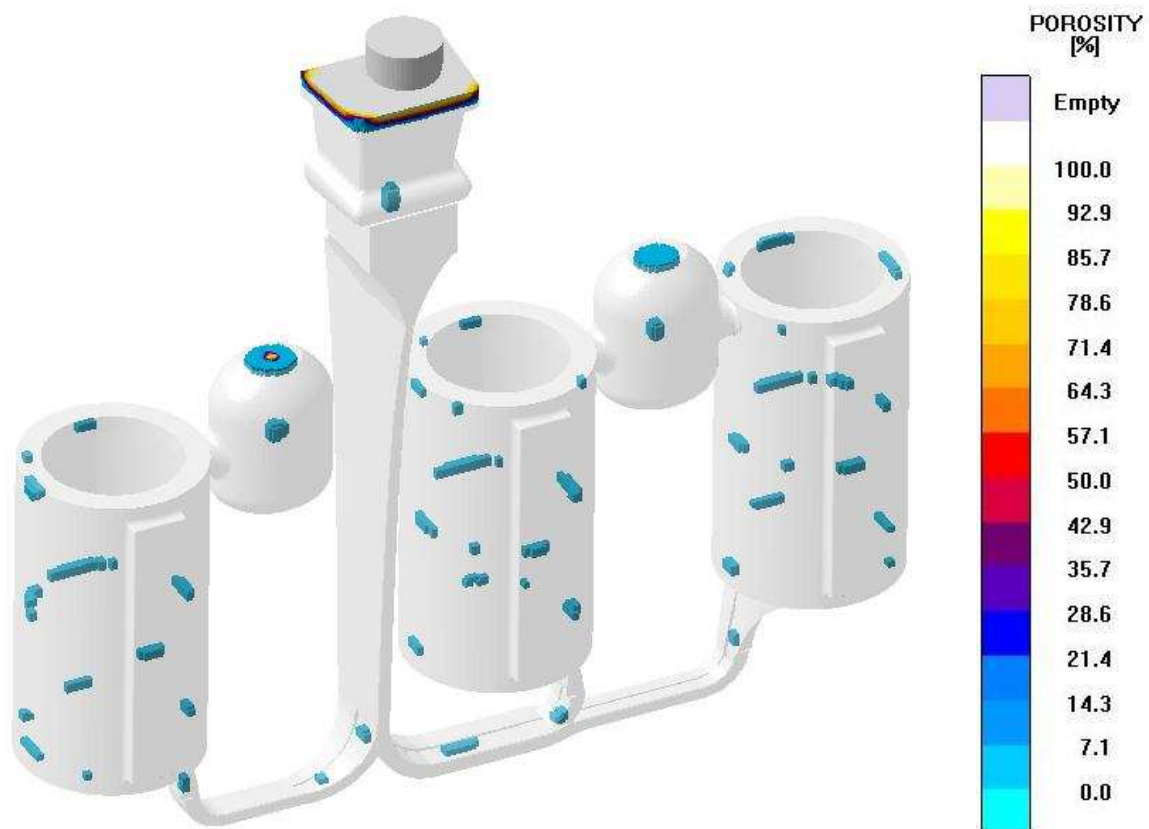


**Figure 4-9 Simulation results – The streamlined layout**

The simulation results from the streamlined layout show that the down runner is not completely filled until 22% filled. But it is also seen that the reason for this is the filter placed under the pouring cup. The filter simply reduces the flow rate and thus prevents the filling of down runner until a certain back pressure is build up. The flow pattern of the first melt to enter the castings is very calm and it is clearly seen how the fan gates help to spread out the flow of melt around the core. The remaining of the filling is just as calm and it is seen that the melt enters the feeders not simultaneously but almost.

The temperature in the feeders at the end of the filling is seen in the traditional layout to be around 1380°C whereas the temperature in the streamlined layout is found to be around 1340°C. So the difference in temperature in the feeders is only of around 40°C even though the feeders in the traditional layout are hot and in the streamlined cold. The reason why the feeders are not any colder in the streamlined layout is the high flow rate reducing the loss of heat during mould filling. The temperatures in the final results from the filling reveal a much more even temperature distribution in the castings than what was seen in the traditional layout. This is due to the flow pattern during filling which gives a more beneficial heat distribution and hence more uniform material property in the castings.

The results from the solidification simulation seen in Figure 4-10 reveal a tendency for small porosities in the centre flange. These should be examined in the real castings to see if they will lead to rejection of the castings.

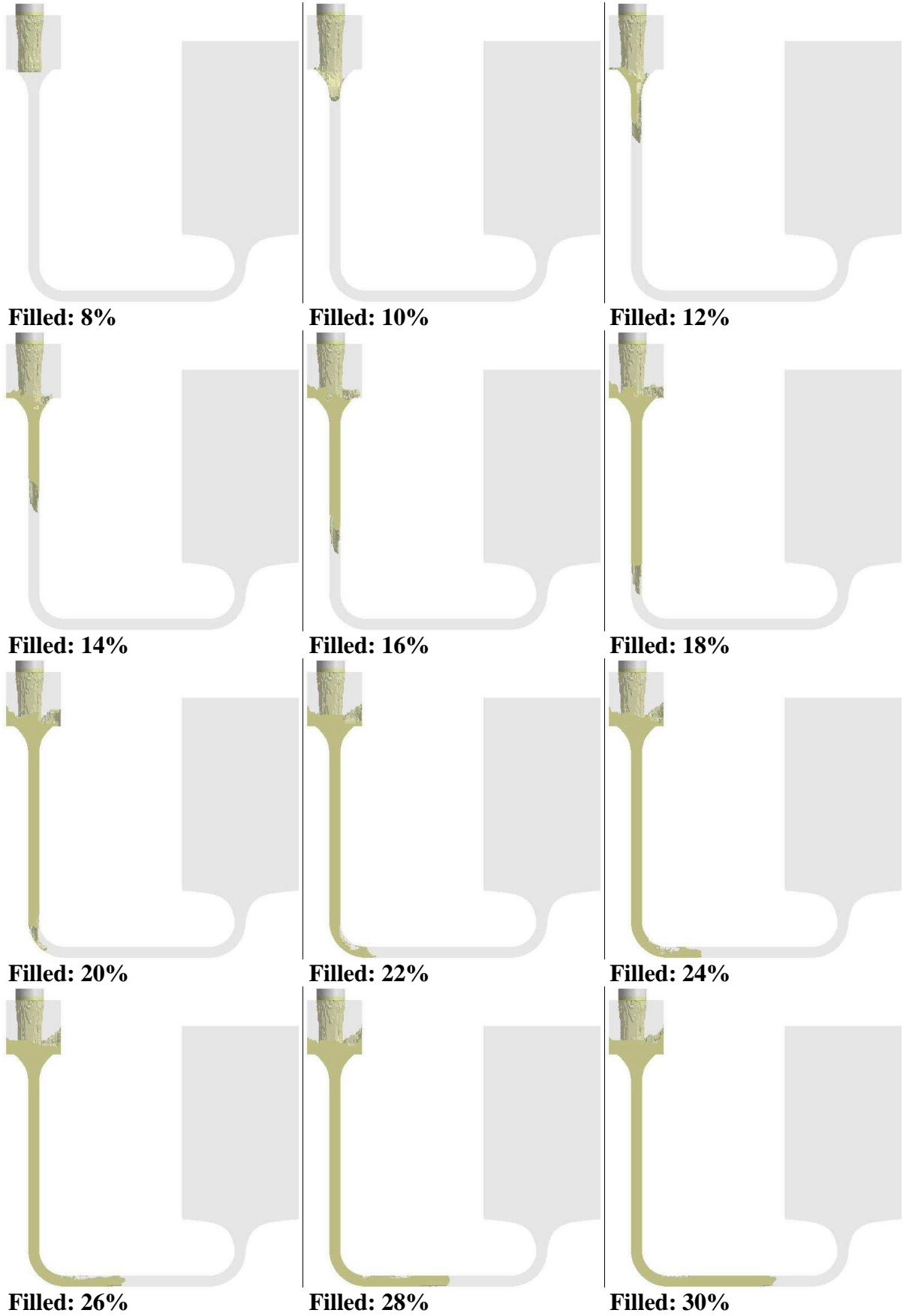


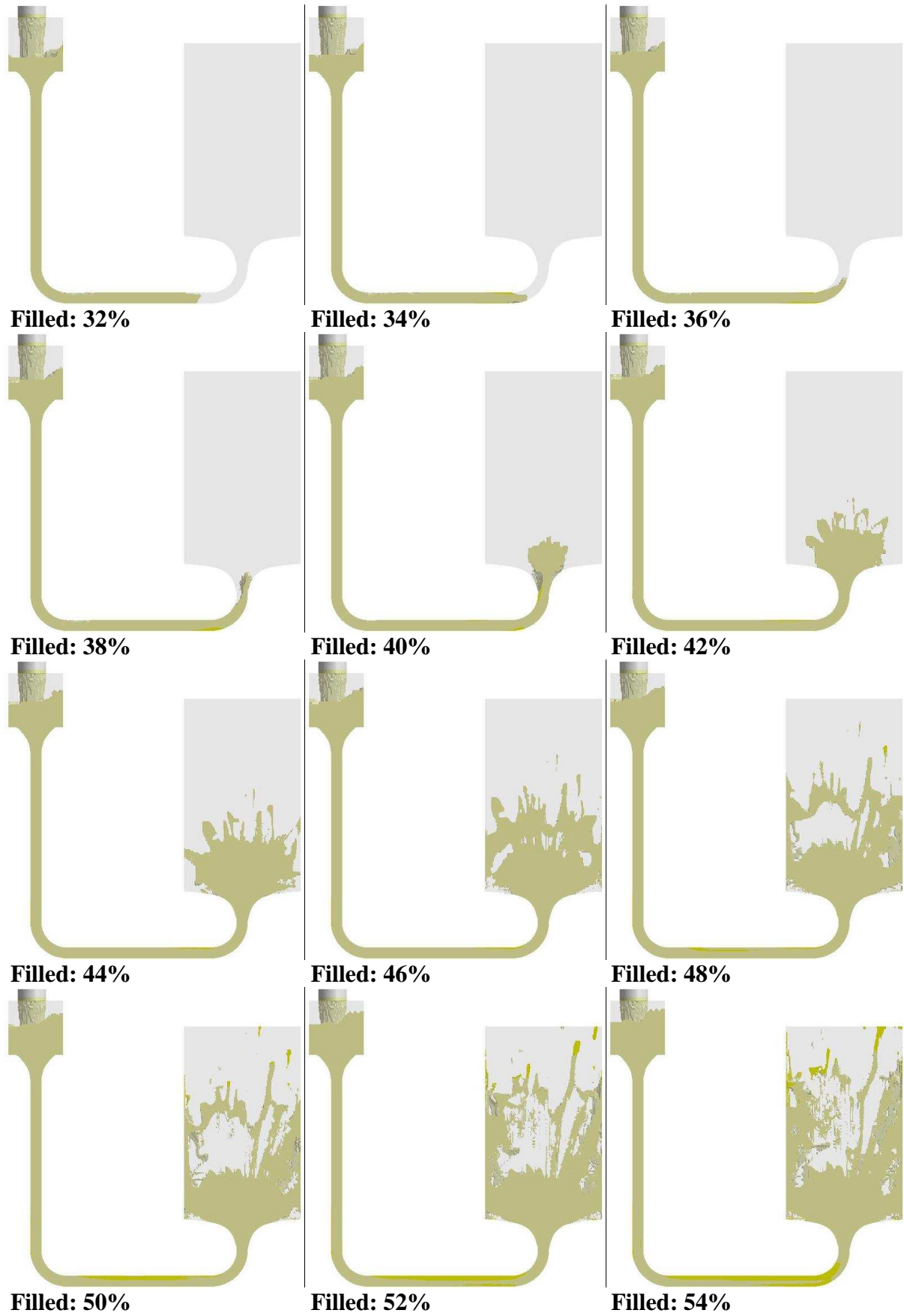
**Figure 4-10 Porosities found in the simulation of the solidification. The simulation is based on the results from the simulation of the mould filling.**

### 4.5 Runner width

In one of the later chapters called ‘Runner width’ a full description of a series of experiments that have been conducted is found. The passage here is to describe the problems that were encountered when simulating the layout. As it is also described later in detail the streamlined layout results in a filling time three and a half times shorter than what is normally recommended for a traditional gating system. This means that the ability to control the melt flow of the fan gate is tested. Selected parts of the results of the simulations are seen in the following. The full set of results is found in Appendix 1 – 14.1.4. The temperature scale is the same as before, seen in Appendix 1 – 14.1.1.







The simulation shows that the down runner is kept full until 20% is filled. Then the simulation from 22% filled till 42% filled reveals small problems in keeping the horizontal runner full. By comparing the simulation results with the results from the glass plate experiments in the chapter 'Runner width' it is seen, that from the result at 44% filled the simulation does no longer represent what is observed in reality. The simulation predicts that the front of the melt disintegrates and the melt splashes all the way to the top of the mould at 50% filled. From then there is no longer any real tendencies or flow patterns in the mould filling. The reason for the problems in simulating the actual mould filling is that it is not yet possible to take surface tension into account. In reality it is the surface tension of the melt that helps keeping the front of the melt coherent in the streamlined gating systems the way it is seen in the glass plate experiments.

### 4.6 Conclusions

The conclusion regarding simulation of mould filling using streamlined gating systems is that Magmasoft gives very reliable results for the flow through the runners but there are problems regarding the fan gates. The simulations reveal that the problems occur when the flow rate increases too much in the fan gates relative to what is normally recommended for the flow rate for in-gates in traditional layouts. Due to these problems in simulating the flow through the fan gates, simulations have not been used for the remaining layouts in this project. After all, most of the layouts here give these very high flow rates.

The reason for the error in the simulations is most likely that it is not possible to take the surface tension of the molten metal into account in Magmasoft. It is possible in other commercial software packages to put the surface tension into the calculations. However the computational time is very long when doing this in slightly complicated geometries like the cases here. At the same time it is also very difficult to find good data for the surface tension that can be used.

## References

**[Ref. 4-1] Hansen, P.N., Hattel, J. – Design af støbte komponenter med integreret modellering. Teknisk nyt special 41, 2005**

**[Ref. 4-2] Tech Inno – Teknisk Rapport, Sagsnummer 2002-4-1, version 2002-4-1 ver 01**

**[Ref. 4-3] Lagarde, C. – Optimisation of Casting Processes with Numerical Simulation. Technical University of Denmark, 2005**

**[Ref. 4-4] Magmasoft Version 4.4 – Online Help, 2007**



## 5 Experimental facilities

Throughout the project experiments have been carried out in different places. First of all a number of experiments have been carried out at the experimental foundry at DTU. Furthermore experiments concerning casting in real production have been carried out at both Dania A/S and Frese Metal- and Steel Foundry A/S. Finally experiments using real-time X-ray radiography were carried out at University of Birmingham.

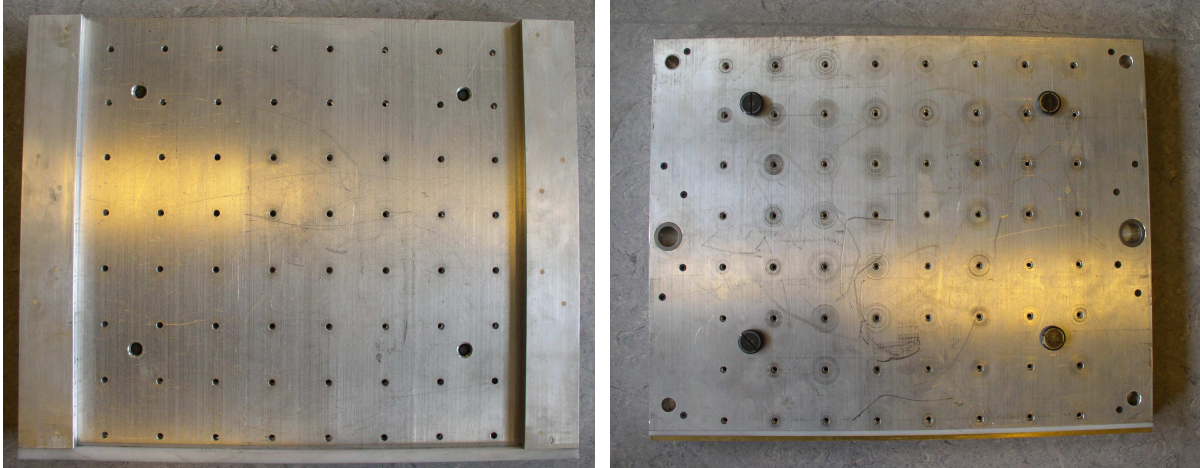
### 5.1 Facilities at DTU

In the beginning of this project the majority of the foundry was renovated. This included installation of a new sand plant, new furnaces for melting, and a new platform to make an easy access from the furnaces to the Disamatic automatic moulding machine. In the following a description of some of the parts will be found.

#### 5.1.1 Module pattern plates

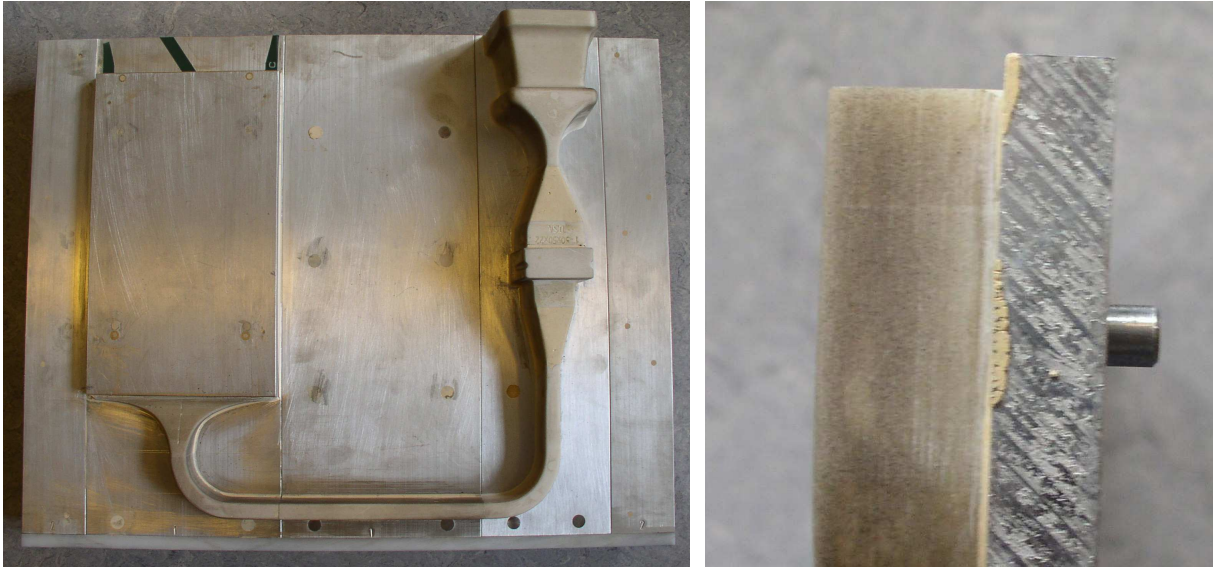
Often when making laboratory test-castings many parts from other pattern plates could be reused. This could be either to try different in-gates for the same casting or to see how the design of the pouring cup or down runner influence the flow pattern in the rest of the filling. Therefore it is convenient to have a system where it is easy to replace parts of the gating system and reuse the remaining parts. By doing this a lot of time in the pattern workshop is saved and it is easy to be sure that as many parameters as possible are kept constant from one experiment to the other. The solution is a system build up in easy replaceable modules for mounting on a base pattern plate.

The base pattern plates are in reality normal aluminium pattern plates for the automatic moulding machine the Disamatic 2110, which is described in the following passage. The base pattern plates have a number of precisely positioned holes for mounting the different modules that in combination makes up the entire layout. The base pattern plates can be seen in Figure 5-1 below.



**Figure 5-1** The base pattern plate. To the left: The front. To the right: The back side.

The modules are made by mounting the different parts of the gating system on to 10mm thick aluminium plates. A layout consisting of three modules is seen to the left in Figure 5-2. The modules in this example are parallel and reach from top to base of the base pattern plate. As for example this makes it easy to try different down runners. The layout could of course have been divided differently for other purposes.



**Figure 5-2** To the left: A layout consisting of three modules each going from the top to the bottom of the base plate. To the right: a close up of a module seen from the bottom. From left a part of the runner is seen. In the middle the 10mm module plate and to the right the lower part of the guide pin is seen.

For mounting the modules the guide pin seen in Figure 5-3 had to be designed and manufactured. The guide pin is 15mm long and the aluminium plates for the modules are 10mm thick. This means that the guide pin goes through the module plates. This can be seen to the right in Figure 5-2. The guide pin fulfils two purposes. First of all the guide pin is used for positioning the modules precisely. Secondly the guide pin is used for mounting the modules on to the base plate using a bolt from the backside of the base pattern plate. As can be seen in the figures here this means that the modules are easy to replace and the guide pins leaves a perfectly smooth surface of the moulds.



**Figure 5-3 Guide pin designed for mounting the individual modules on to the base pattern plate. The length of the pin is 15mm.**

### 5.1.2 Sand Plant

The heart of the sand plant for greensand is of course the sand mixer placed in the basement of the foundry. The mixer is an EIRICH R12 mixer with a capacity of 120kg at a mixing time of around 40s. The total capacity is 2,5tons per hour.

The rest of the sand plant has been built especially for the size of the test foundry, meaning that it was not possible to build up the sand plant as small as necessary using normal commercially produced parts. Normally the sand is moved around using conveyer belts but in the sand plant here the sand is moved primarily using screw conveyers.



### 5.1.3 Automatic moulding machine

Moulds were made on a Disamatic 2110. The Disamatic produces flaskless vertically parted moulds. The Disamatic 2110 produces moulds in the size of 400 mm in height and 500 mm in width and with a thickness between 100 mm and 315 mm.

### 5.1.4 Melting Furnaces

For melting new furnaces from Inductotherm were installed as part of the renovation of the foundry. The furnaces have a 125 kW VIP Power-Trak power supply. In this project the tilt furnace with a capacity of 150 kg of iron have been used.

### 5.1.5 Magnesium treatment ladle

Due to the fact that the new furnace for melting iron has a larger capacity than the old furnace a new magnesium treatment ladle had to be designed and constructed. With a capacity of 90 kg of molten iron the old treatment ladle used the tundish cover principle, which has proven to give very consistent results. It was therefore decided to design the new ladle according to the same principles. In use the old ladle did have some problems that should be overcome if possible in the new design. One of the problems was a high loss of heat due to first of all the small amount of melt but also the insulating capacity of the old lining. Therefore a new material for the lining was used. The material is called 'Kaltek iso 16 s' and is produced by Foseco. The material is easy to use and gives a good insulation because it is very porous compared to alternative materials.

Another problem that has been experienced using the old ladle was getting the tundish cover on and off the ladle. To move the tundish cover the problem was that the ladle has a mechanism to lift the entire cover before it is possible to swing it to the side. The problem is that the mechanism is very sensitive to the heat of the melt in the ladle which can make it very difficult to operate. The new ladle is designed so that no mechanism for lifting the tundish cover is needed. The tundish cover can simply slide

in place, which eliminates the previous problem. At the same time the cover is supported when closed minimizing the stress on the suspension.

According to the capacity of the new furnace for melting iron the new treatment ladle has a capacity of a 150 kg of molten iron. A picture of the new treatment ladle can be seen in Figure 5-4. A picture showing the inside of the ladle is also seen here.



**Figure 5-4 To the left: The new magnesium treatment ladle designed for 150kg of molten iron. To the right: the inside of the ladle.**

### 5.1.6 Spectrometer

The foundry is equipped with a spectrometer for testing of chemical compositions in alloys. The spectrometer is a Spectromax from Spectro. The foundry has a range of references including for cast iron.

## 5.2 Facilities at Dania A/S

### 5.2.1 Pattern making

Dania A/S has its own workshop for pattern making. Normally this workshop only constructs the gating system. The rest is done by sub-contractors.

### 5.2.2 Core shop

The foundry has its own core shop producing cores in a wide range of qualities regarding sand and binder systems.

### 5.2.3 Moulding machine

The moulds used at Dania are all made from green sand. The moulding machine used for the experiments at Dania A/S is a Disamatic 2013 MK5. The size of the moulds is 600mm in width and 480mm in height.

### 5.2.4 Pouring device

The moulding machine is fitted with an automatic pouring device. A laser is used to position the pouring device precisely over the pouring cup. After positioning a pouring time is typed in for the first mould and the pouring time is then adjusted if needed for the next mould. In this way a correct pouring time is found during the first couple of moulds. The melt for the pouring device comes directly from the magnesium treatment ladle as soon as the treatment is over. The remaining molten iron is not used if the time from when the magnesium treatment is performed to the pouring into the moulds exceeds 20 minutes.

### 5.2.5 Machining the castings

Dania has its own fully equipped factory for machining the castings.

## 5.3 Facilities at Frese Metal- and Steel Foundry A/S

### 5.3.1 Core shop

The foundry produces cores using both cold box and beta-set processes. Besides, cores are also made in furan sand.

### 5.3.2 Mould making

Moulds are made from furan sand. Moulds are produced either on the floor or using the fast loop moulding machine.

### 5.3.3 Furnaces for melting

Induction furnaces are used for melting.

### 5.3.4 Pouring

The pouring is done from a ladle in a crane. The crane and ladle are operated by two employees.

## 5.4 Facilities at University of Birmingham

### 5.4.1 Mould making

The moulds are made using grade 60 sand (grain size of around 0,34mm) and a ‘pep set’ binder system from Ashland. All moulds are made by hand.

### 5.4.2 Furnace for melting



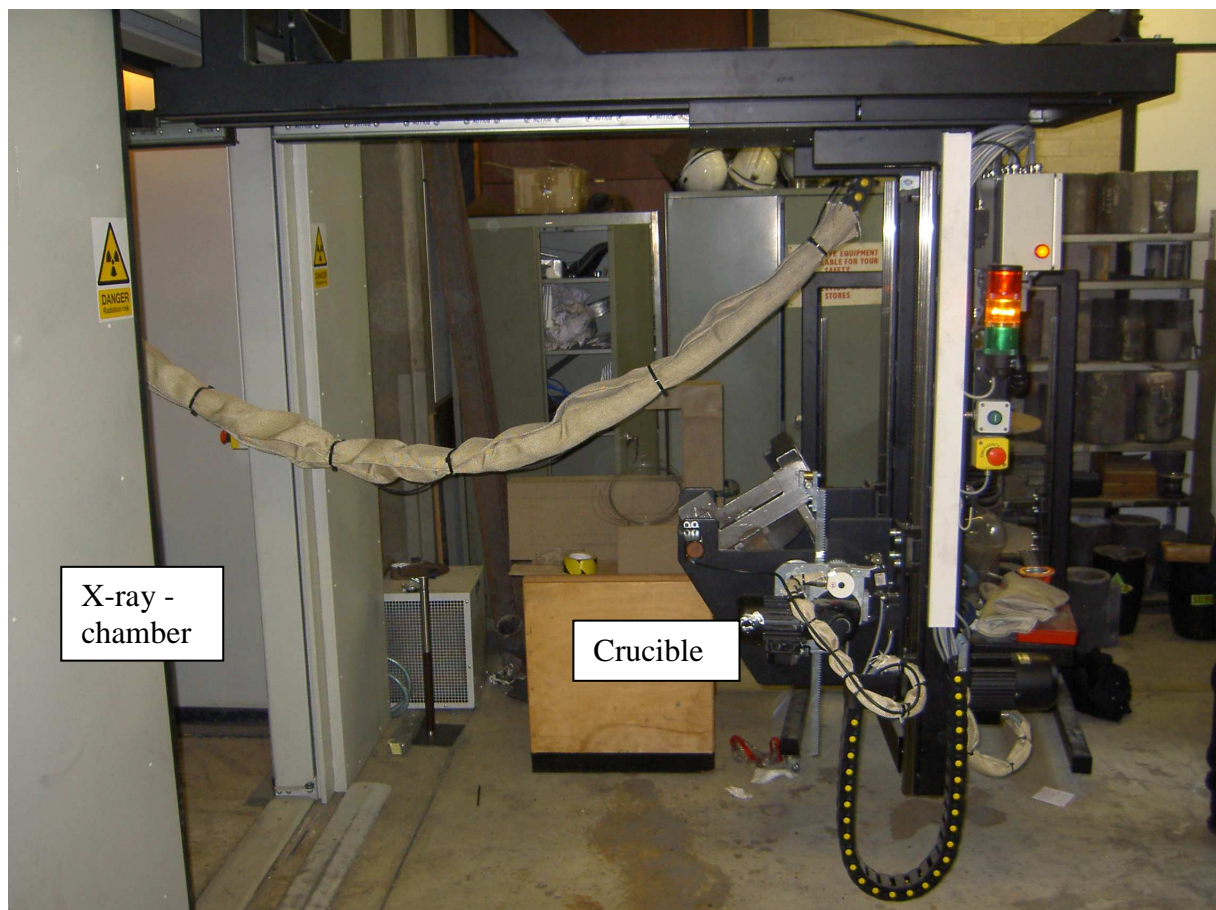
**Figure 5-5** The furnace for melting

For melting, a small crucible is placed in an induction furnace. The crucible contains approximately 8kg of molten iron. A picture showing the furnace can be seen in Figure 5-5. When the metal is ready and at the right temperature, the crucible is moved from the furnace to the pouring device. This is done to avoid transferring the molten metal

from the crucible in the furnace to another much colder crucible then being in the pouring device. This procedure would cause a considerable heat loss even if it had been possible to preheat the second crucible.

### 5.4.3 Pouring device

The mould is placed inside the x-ray chamber and the pouring is done while the x-ray is on, so it is not possible to pour manually. Therefore a pouring device that can be operated from the control room is necessary. The pouring device can be controlled manually or it can be programmed.



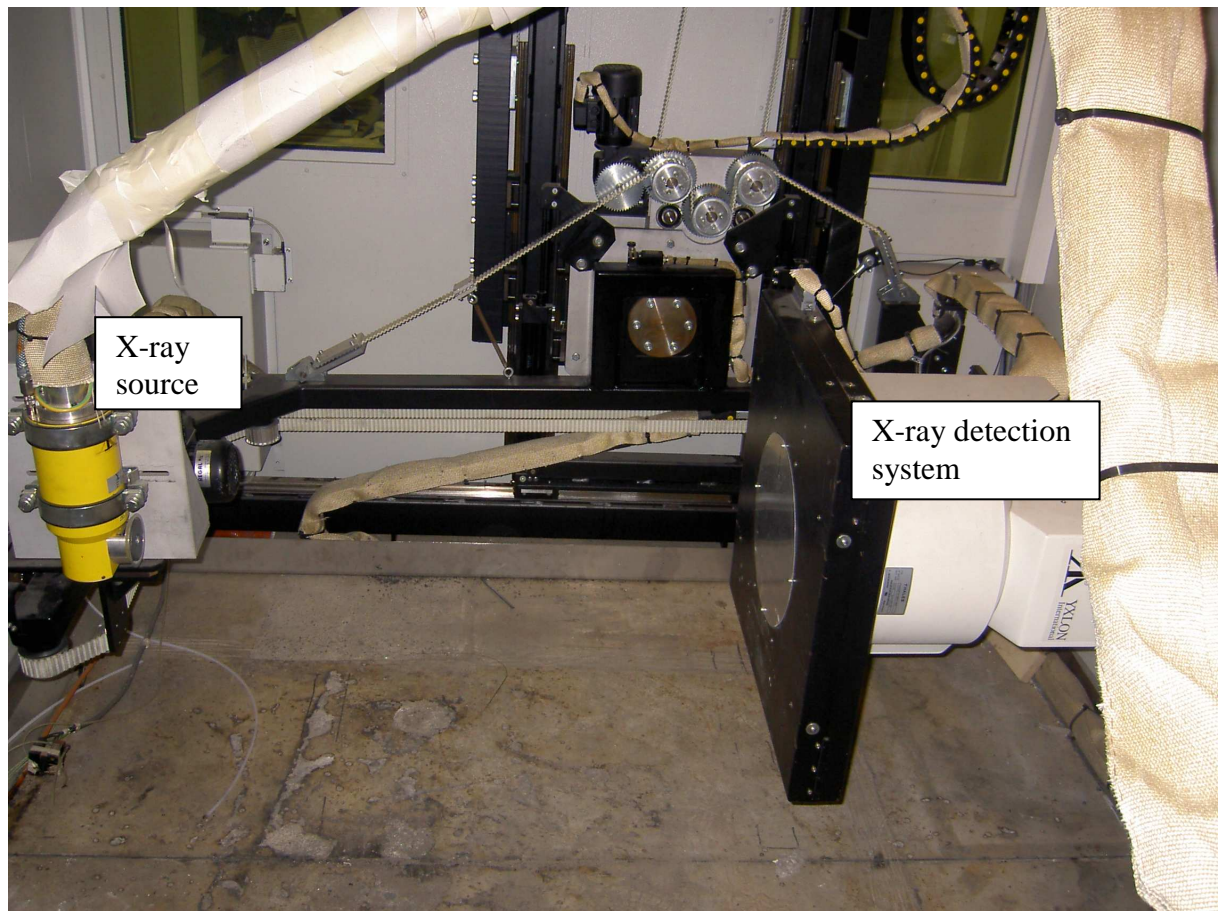
**Figure 5-6** Pouring device being outside the x-ray chamber. The x-ray chamber is seen to the left.

A good way to achieve consistency in how the melt is poured every time is to do the first pour manually while recording all of the movements of the crucible. For the rest of the pours the recorded data can then be used to program the pouring device. In this

way the pouring will become as consistent as possible every time. A picture showing the pouring device outside the x-ray chamber can be seen in Figure 5-6.

### 5.4.4 X-ray chamber

Inside the x-ray chamber there is an x-ray source, seen to the left in Figure 5-7, and an x-ray detection system is seen to the right. The mould is then placed in-between the two.



**Figure 5-7** Inside of the x-ray chamber. To the left: the x-ray source. To the right: the x-ray detection system.

### 5.4.5 Control room

Once the crucible is placed in the pouring device the rest of the pouring process is controlled from the control room. The control room can be seen in Figure 5-8. The following is a short description of the inside of the control room seen in Figure 5-8.



**Figure 5-8 Control room with all the different computers for monitoring, filming, and recording of data.**

At the very top of the picture a television shows a birds eye perspective of what is going on inside the x-ray chamber. This is not recorded but only used for monitoring. At the desk to the very left a screen shows the coordinates for the placement of the automatic pouring device. This is also where the movements of the pouring device are programmed. The second screen from the left is where the recording of the x-ray images are controlled. The software is also used for reviewing the results at different frames per second.

Two windows with leaded glass looking into the x-ray chamber are seen in the wall behind all the computer screens. Below the window to the right the actual control panel is found. From here the pouring device can be moved; the doors to the x-ray chamber can be opened and closed; the placement of the x-ray source and detection can be adjusted, and the pneumatic arm for use with a stopper can be activated. The only thing not controlled from here is whether or not the x-ray is on or off. The

computer screen just above and a little to the left shows only what is seen by the x-ray. The screen in the foreground of the picture to the right is where the movement of the pouring device is recorded. These data can be used to program the pouring device for the following pours. Figure 5-9 shows the cabinet also inside the control room from which the x-ray is controlled. Here it is possible to adjust the voltage (in kV) and the ampere (in mA) depending on the geometry and alloy being cast.



**Figure 5-9 Cabinet from which the x-ray is controlled. This is where the kV and the mA for the x-ray are set. These parameters need to be adjusted considering the geometry and the alloy being cast.**



## References

**[Ref. 5-1] Larsen, Per – Iron Melt Flow in Thin Walled Sections Cast in Vertically Parted Green Sand Moulds. Technical University of Denmark 2004**

## 6 Casting of a valve housing

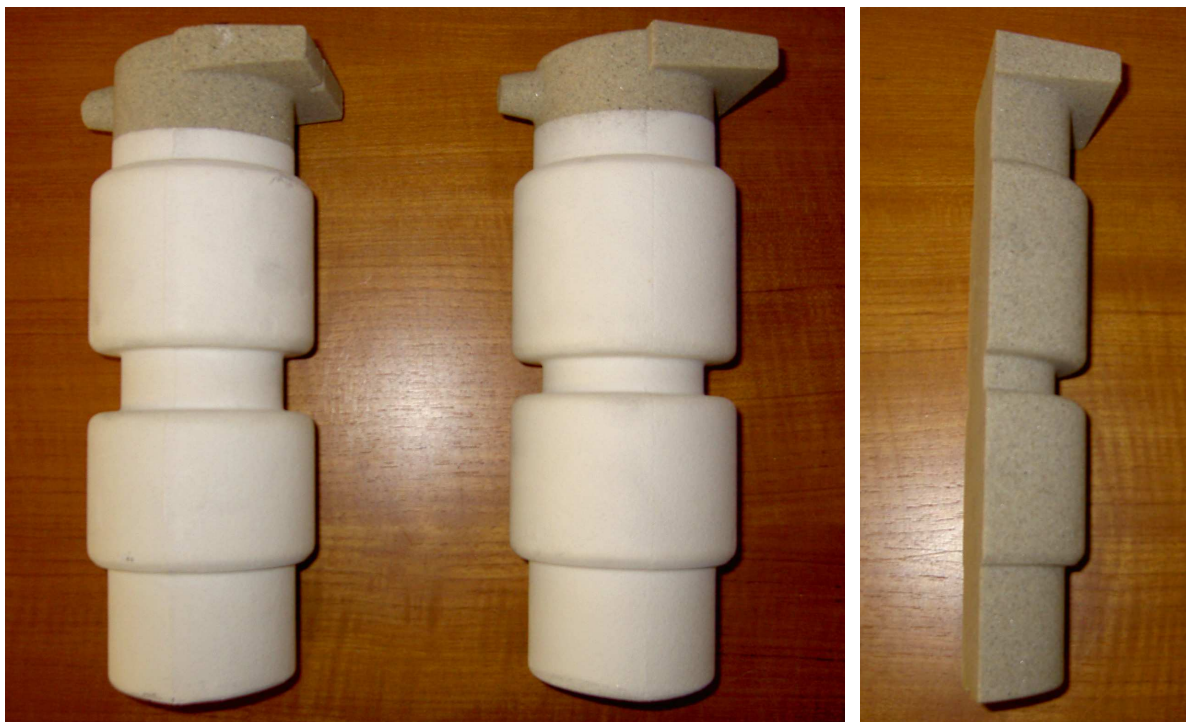
A valve-housing has been cast in order to test the previously presented guidelines for design of a streamlined gating system. Prior to this project the valve housing was already being cast using the traditional gating system presented in the chapter ‘Theory in gating technology’. A new streamlined gating system was designed to make it possible to compare the two ways of designing gating systems. The streamlined gating system is also presented in the chapter ‘Theory in gating technology’. The mould filling of the two layouts has been compared in simulations using the commercial software package Magmasoft as it is presented in the previous chapter ‘Simulation’. To achieve an even better comparison of the two layouts experiments have been conducted where castings were made with both layouts.

The castings were first of all done using the production facilities at Dania A/S. The reason for doing the experiments in a real production line was to see how the streamlined gating system performs compared to the more traditional gating system when used in a real production. This is important due to the fact that many things are easy to do in an experimental foundry like the foundry at DTU but there are a lot of other parameters to consider when operating within a production line. These parameters could be the actual making of the pattern plate, how well the pattern plate performs in use, the pouring time must not exceed the time it takes for the automatic moulding machine to make a mould, the handling of the castings when taken from the moulds, and finally the machining of the castings. Also process parameters, like temperature of the melt, and homogeneity of the sand have to be considered.

The details for castings using the traditional layout are taken from the normal production of the valve housings. The melt is poured at a temperature of approximately 1400 °C. The pouring time for this layout was found from the automatic pouring device to be 6.5 seconds. The castings are all made in ductile iron grade EN-GJS 400-15.

### 6.1 Experimental casting using the streamlined layout

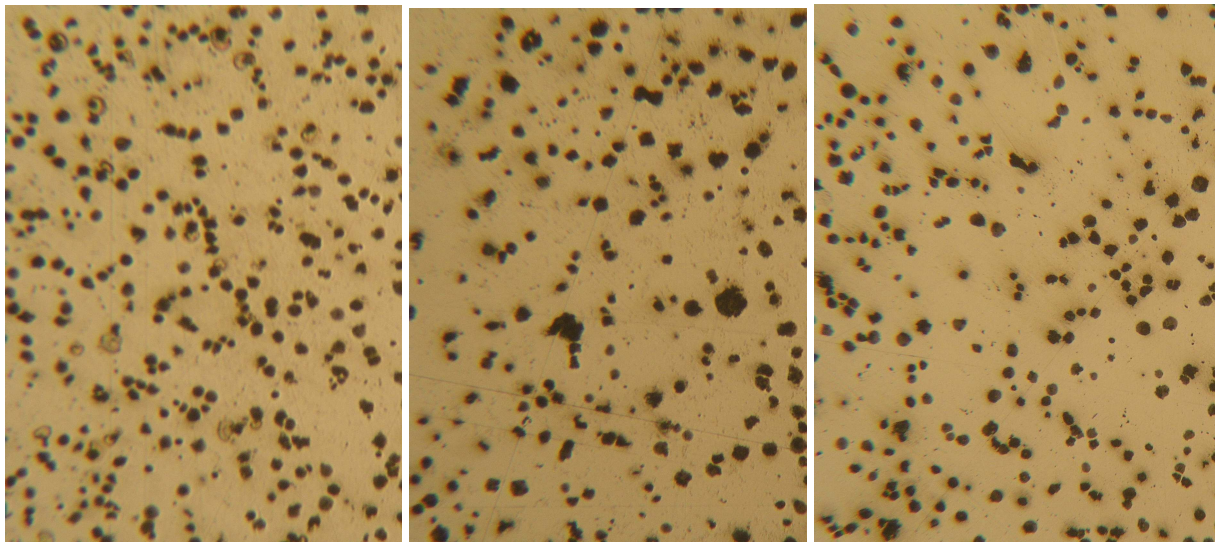
The streamlined gating system was tested in the same way as if it was used in the real production with one exception. In series of five the moulds were made either with or without filter. This means that in the first five moulds a pressed filter was used, but the next five moulds were poured without a filter, then again the next five were poured with a filter and so forth. The reason for using pressed filters and not foam filters was that the traditional layout was normally being cast using pressed filters. Just like the traditional layout the castings are all done in ductile iron grade EN-GJS 400-15. The production facilities at Dania A/S are presented in the previous chapter 'Experimental facilities'. In the chapter 'Simulations' it was shown that the thickness of the centre flange can be reduced by 50%. To do this in practice a new core box had to be made. The difference between the cores can be seen in Figure 6-1. Also a core made for the experiments using glass plate fronted moulds is seen.



**Figure 6-1 To the left: A core for the traditional layout. In the Middle: A core for the streamlined gating system. To the right: half a core used for experiments using glass plate fronted moulds.**

The automatic pouring device was filled with a new portion of molten iron, enough for about 50 moulds. The time from the magnesium treatment of the melt and to the last mould was poured was 18 minutes which is just below the 20 minutes which is normally allowed in the foundry. If more time is used too much magnesium evaporates from the melt and the microstructure of the castings will not be approved. To be sure that the melt lived up to the requirements, samples were taken for analysis. First a sample for analysis of the mechanical properties was cast. The results from this can be seen in Table 6-1.

Other samples were taken in order to analyse the composition of the melt and the microstructure to see if too much magnesium has evaporated. One of each sample was taken along with the first mould, the 25<sup>th</sup> mould and the last mould. The results from the composition analysis can be seen in Table 6-2 together with the pouring temperature. The results from the microstructure samples can be seen in Figure 6-2. All of the samples lived up to the normal requirements. The mould filling time was found to be 4.1 seconds for all moulds both with and without filter.



**Figure 6-2** Microstructures from the three samples cast along with the castings. There is no scale on the pictures since the purpose is just to make sure that not too much magnesium has evaporated. Left picture: start. Middle picture: 25<sup>th</sup> mould. Right picture: end.

Tensile Strength:	624 N/mm <sup>2</sup>
0,2 Tension:	408 N/mm <sup>2</sup>
Elongation:	12%
Brinell Hardness:	179

**Table 6-1 Mechanical properties for the first sample poured**

Sample	C:	Si:	Mn:	Cu:	Mg:	S:	Pouring temperature
201-Start	3,64	2,54	0,31	0,30	0,05	0,01	1385 °C
201-Middle	3,65	2,56	0,30	0,30	0,05	0,01	1312 °C
201-End	3,62	2,55	0,30	0,30	0,04	0,01	1268 °C

**Table 6-2 Composition and pouring temperature of the melt found from the samples cast along with the experiments**

## 6.2 Comparison of the traditional- and the streamlined layout

### 6.2.1 Reduction in pouring time

The traditional layout has a pouring time of 6,5s whereas the streamlined layout has a pouring time of only 4,1s. Often the pouring time is critical when using automatic moulding machines like for example the Disamatic used in these experiments. If the pouring time is too long it will slow down the moulding machine reducing the overall production capacity in the foundry. Therefore the possibility of reducing the pouring time considerably by using streamlined gating systems without reducing the quality of the castings can be of great economical value to the foundry.

### 6.2.2 Reduced minimum pouring temperature

Normally it is desired in most iron foundries to have a pouring temperature of around 1400°C. As can be seen in Table 6-2 the pouring temperature for the experiments using the streamlined gating system starts at 1385°C. The reason for this rather low temperature was that the magnesium treatment ladle had not been used prior on the day of the experiments and the temperature of the ladle was low. The time it takes from the magnesium treatment to the last mould is poured is 18 minutes. In this time the temperature in the automatic pouring device decreases to 1268°C. This temperature would normally be considered as much too low and cold runs would definitely be expected. The experiments proved however that this was not the case. No cold runs

were found, and in fact it was not possible afterwards to tell the difference between the castings from the beginning and the end of the experiments.

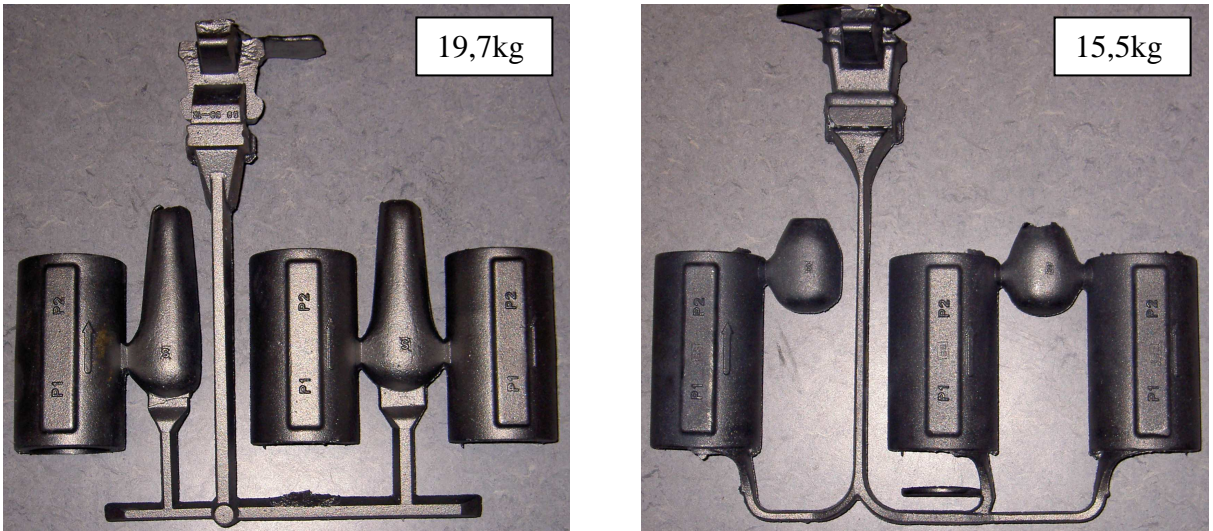
**6.2.3 Reduction in poured weight**

Results from the layouts can be seen as cast in Figure 6-3. The weight reductions are summarized in Table 6-3.

	Traditional layout	Streamlined layout	Weight reduction
Total poured weight	19,7kg	15,5kg	4,2kg
Weight of gating system	5,6kg	4,5kg	1,1kg

**Table 6-3 Weight reductions**

It was found that the poured weight of the traditional layout is 19,7kg and the poured weight of the streamlined layout is 15,5kg. This means a total reduction in poured weight of 4,2kg. The weight of the gating systems, meaning the layouts without the castings and the feeders was found to be 5,6kg for the traditional layouts and 4,5kg for the streamlined layouts. So the weight reduction for the gating systems is 1,1kg.



**Figure 6-3** Picture to the left: castings with the traditional layout. Picture to the right: castings with the streamlined layout.

**6.2.4 Handling of the as-cast layouts**

A parameter in the evaluation of how well a layout performs in the production is how easy it is to remove the feeders and the gating system from the casting. In the case

study here when the traditional layout is being cast the gating system it self is easily removed. Often but not always the gating system is seen to break off in the shake out. If the gating system do not break off it obviously takes an additional operation. The removal of the feeders is more difficult. The feeder needs to be cut off and they are positioned on a round surface making them more difficult to remove without damaging the valve housing than if it had been on a flat surface.

In this case study removing gating system and feeders in the streamlined gating system is a bit more complicated. The use of round fan gates has the effect that the gating system do not break off and hence needs to be cut off. The removal of the feeders is more or less the same as for the traditional layout. So in total in this example the cost of using the streamlined gating system is that a possible operation of breaking off the gating system has been replaced by the operation of cutting off the gating system. Beside this the cost should be the same for the two layouts. Had the fan gates been flat it would also have been possible to simply brake off the gating system in the streamlined gating system as well.

### **6.2.5 Machining of the castings**

Normally with the traditional gating system the castings would be heat treated prior to machining. This is done to achieve more uniform material properties so that the difference in especially the hardness of the material is not too large. This is important for reducing the tooling cost at the machining workshop. In this project the aim is to design gating systems so that the temperature field in the castings after mould filling is more uniform than with the traditional gating system. In this way the material properties will be more uniform and it will not be necessary to have the castings heat treated. To see if this was the case the castings from the streamlined gating system were machined with no heat treatment at the workshop at Dania for evaluation. The following was reported from the workshop: During the turning process of the two ends the wear on the tooling was increased by 15-20% having the same operation time compared with the traditional heat treated castings. In the milling process of the centre

flange no additional wear on the tooling was registered and it also had the same operation time compared with the traditional heat treated castings. [Ref. 6-1]

The conclusion for this part of the experiments was that using the streamlined gating system heat treatment is no longer necessary. The extra cost from the increase tool wear during the turning process is much less than the cost of heat treatment and hence do not make the heat treatment economical viable.

### 6.2.6 Microstructure analysis of the centre flange

Leaving out the heat treatment of the castings of course has an influence on the microstructure. To evaluate the difference in microstructure in the centre flange between castings from the traditional layout after the heat treatment and castings from the streamlined gating system samples were taken from the flange for analysis in optical microscope. The centre flanges for the analysis is seen in Figure 6-4.



**Figure 6-4** The picture shows the two centre flanges and the numbers indicates the numbering and the positions of the samples. To the left: Centre flange from the streamlined layout. To the right: Centre flange from the traditional layout.

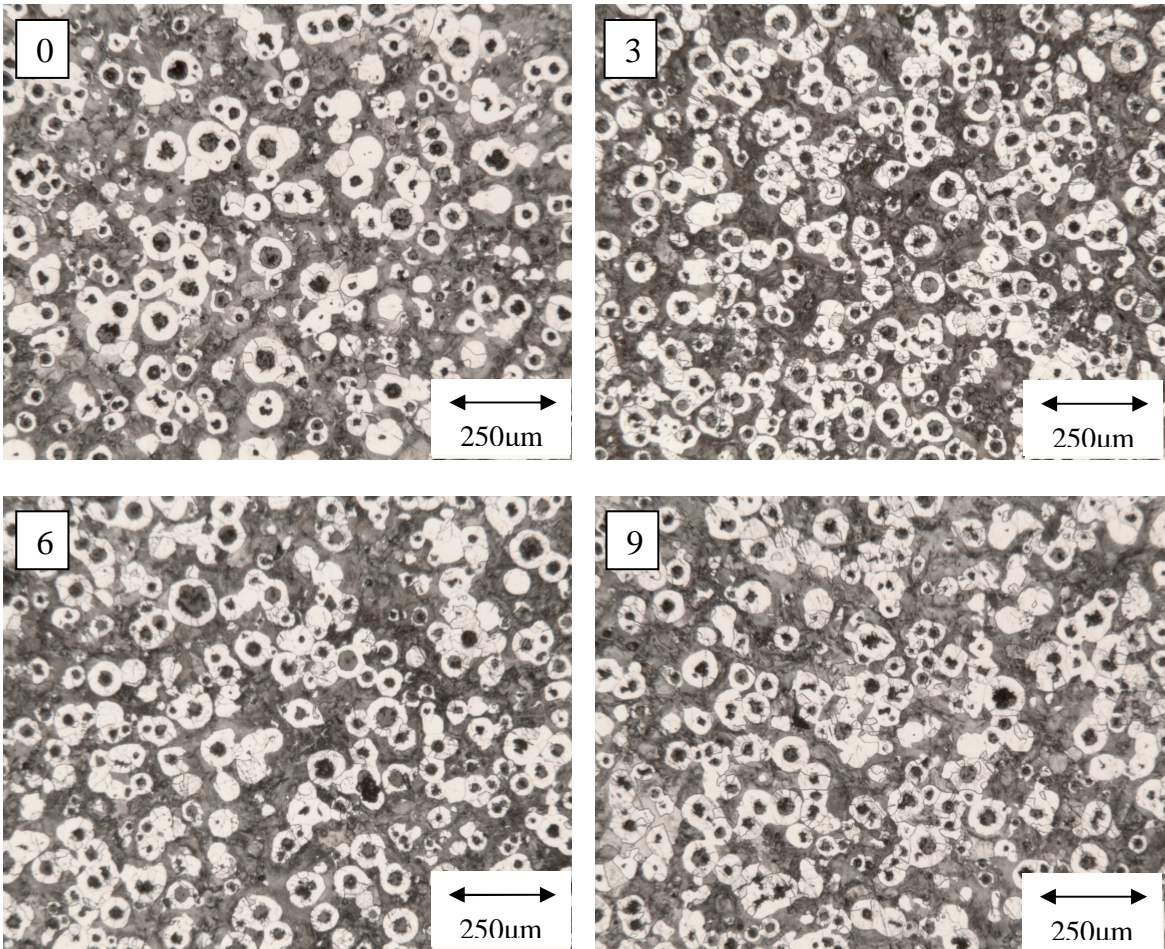
The samples from the traditional layout are seen in Figure 6-5 and the samples from the streamlined layout are seen in Figure 6-6. All of the polished samples have been



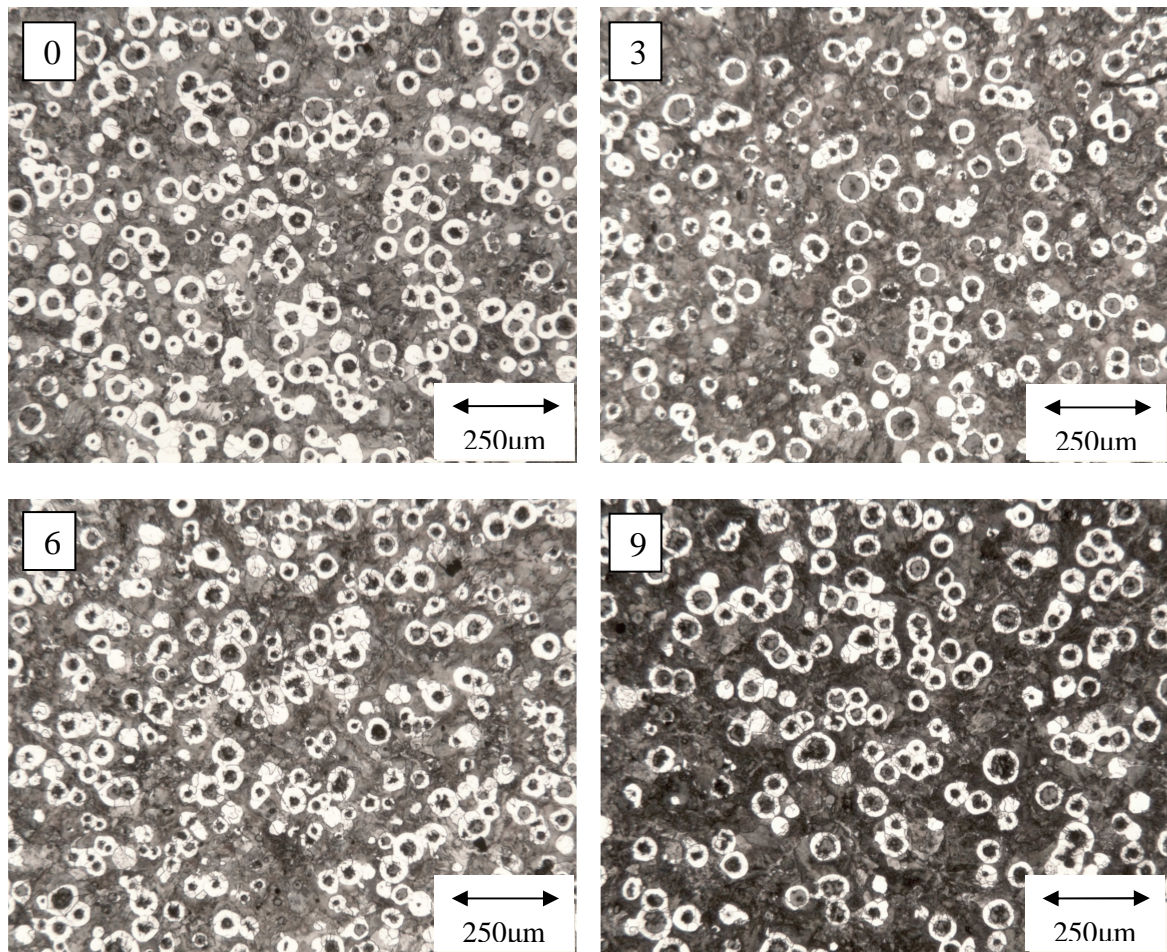
etched using a 2% Nital solution. The position '0' for the traditional layout is where the feeder is attached.

The effect of the position of the feeder in the traditional layout is seen in both the polished samples but also in the nodule count in Table 6-4. The position 0 in the traditional layout clearly has a lower number of nodules than the positions 3 and 6.

The microstructures in the four different positions for the centre flange from the streamlined gating system are very similar. The uniformity of microstructures here proves the point that the heat distribution in the casting from the mould filling is very uniform and beneficial for the casting. This can also be seen in Table 6-5.



**Figure 6-5 Microstructures in the centre flange from the traditional layout**



**Figure 6-6 Microstructures in the centre flange from the streamlined layout**

The microstructure from the streamlined layout has slightly less ferrite than the microstructures from the traditional layout. This is probably because the casting from the streamlined layout has not been heat treated. The higher content of pearlite in the casting from the streamlined layout is beneficial for the mechanical properties of the casting.

The effect of the side bar in position 9 is seen in both layouts in the nodule count. When comparing the four positions it is seen how the hotspot at the sidebar reduces the number of nodules. At the same time the amount of graphite is the same in all positions. The hotspot prolongs the solidification time meaning that the nodules have more time to grow while reducing the number of nodules.

	Traditional 0	Traditional 3	Traditional 6	Traditional 9
Graphite [Area%]	8,0	7,9	8,2	7,8
Ferrite [Area%]	31,9	40,2	41,5	42,1
Pearlite [Area%]	60,1	51,9	50,3	50,1
Nodule count [>10 $\mu$ m]	147	190	184	156

**Table 6-4 Microstructure analysis of the samples from the traditional layout.**

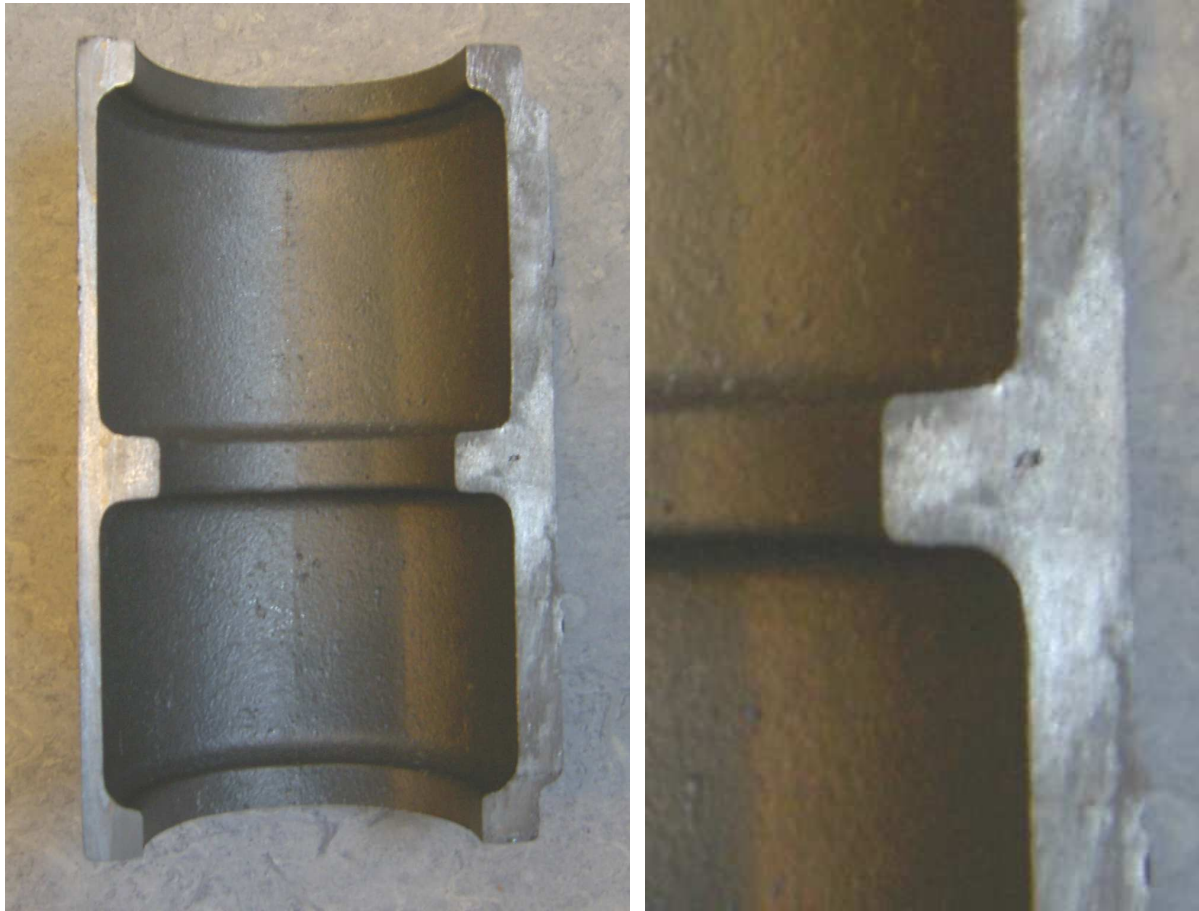
	Streamlined 0	Streamlined 3	Streamlined 6	Streamlined 9
Graphite [Area%]	8,3	7,5	7,8	8,3
Ferrite [Area%]	26,9	20,6	27,0	24,0
Pearlite [Area%]	64,8	71,9	65,2	67,7
Nodule count [>10 $\mu$ m]	208	193	203	152

**Table 6-5 Microstructure analysis of the samples from the streamlined layout.**

### 6.3 Porosities

In the chapter ‘Simulations’ the results indicated a tendency for shrinkage porosities in the centre flange in the streamlined layout. The tendency is due to the considerably smaller feeders that are also positioned higher. A casting has been cut vertically through the sidebar to see if porosities are present. The most likely place to find porosities is in the centre flange in the side where the thick side bar also is. In Figure 6-7 the casting that has been cut through is seen. The picture shows a small porosity in the centre flange right in the centre of the hot spot that occurs by the combination of the centre flange and the sidebar. This is also the position ‘9’ seen to the left in Figure 6-4.

When cutting the casting some material is obviously removed meaning that it is likely that a part of the porosity has disappeared. Therefore it is difficult to be sure that the porosity is not more severe than first noticed. It should be mentioned that no sign of the porosity was found on the other half of the casting.



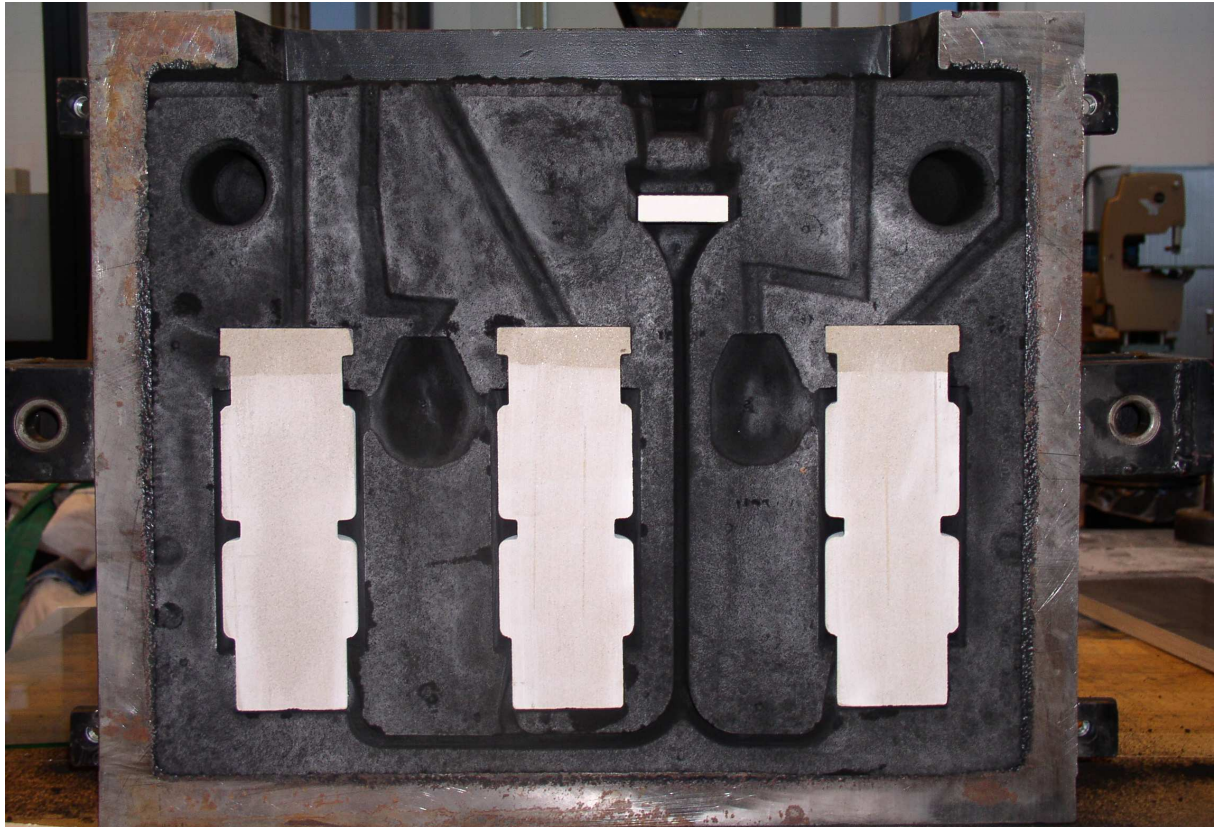
**Figure 6-7** To the left: Casting from the streamlined gating system that has been cut through vertically. The right side of the casting is middle of the thick bar on the side of the casting. A small porosity is seen here. To the right: A close up of the small porosity.

The fact that porosities are seen proves that the feeding is insufficient. However it should be investigated if the size of the porosity has the effect that the mechanical properties of the casting no longer lives up to the requirements. Many castings are accepted even though porosities can be found as long as the size and position of the porosities do not compromise the use. Feeding and design of feeders are not the focus in this project so no work has been done to try and optimize the feeders.

### 6.4 Experiments with glass plate fronted moulds

To get a clearer picture of the flow patterns during the mould filling, experiments were carried out with glass plate fronted moulds. The idea is that the one half of the mould is replaced by glass. In this way it is possible to film the mould filling. A picture of the mould can be seen in Figure 6-8. The streamlined gating system is symmetric at the

parting line so there should be very little or no difference in the flow patterns between the experiments with half a mould and an entire mould. To be able to mount the glass plates on the mould special, halved cores were made. An example of these cores is seen to the right in Figure 6-1. In Figure 6-8 the cores are seen when placed in the mould. The pressed filter is seen at the top, just above the funnel.



**Figure 6-8** In the picture a mould used for the experiments using glass plate fronted moulds is seen.

### 6.4.1 Results

Part of the results from one of the glass plate fronted moulds can be seen in the following. The full set of frames can be seen in Appendix 2 – 14.2.1. The films from all the experiments can be seen on the DVD.

Streamlined gating system – Pressed filter



Time 0,04s

Time 0,08s

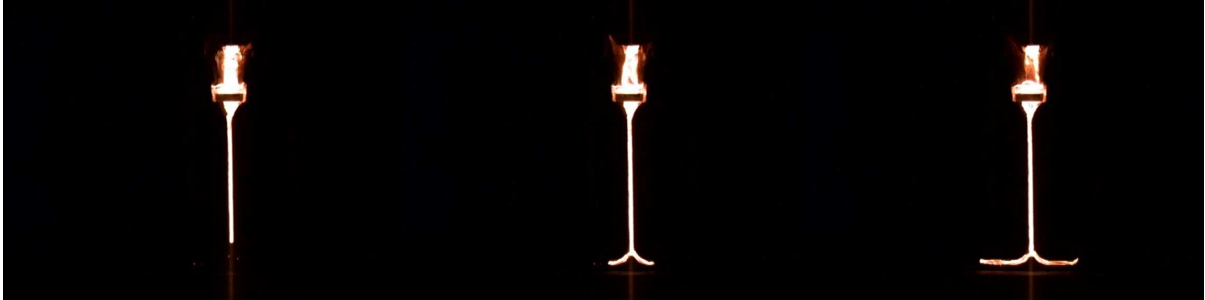
Time 0,12s



Time 0,16s

Time 0,20s

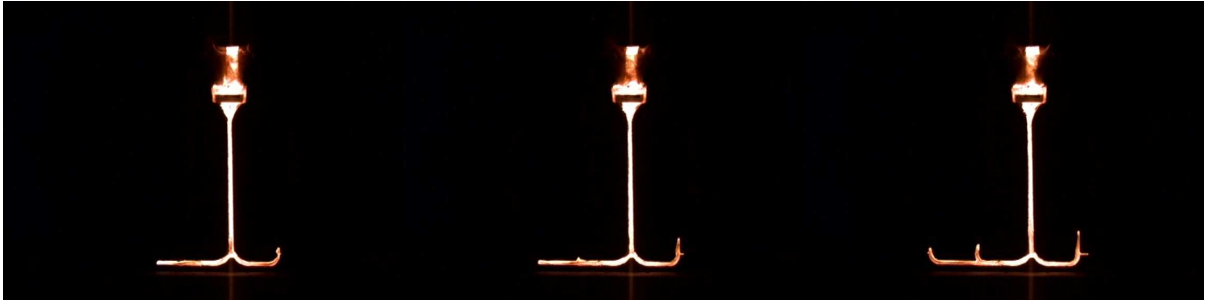
Time 0,24s



Time 0,28s

Time 0,32s

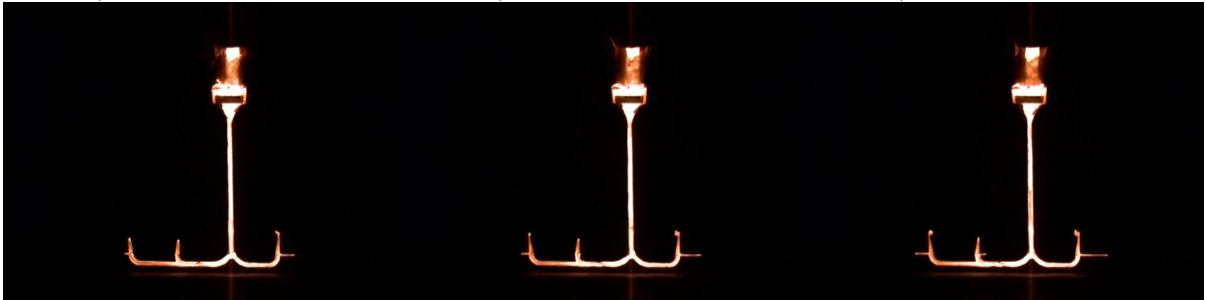
Time 0,36s



Time 0,40s

Time 0,44s

Time 0,48s



Time 0,52s

Time 0,56s

Time 0,60s

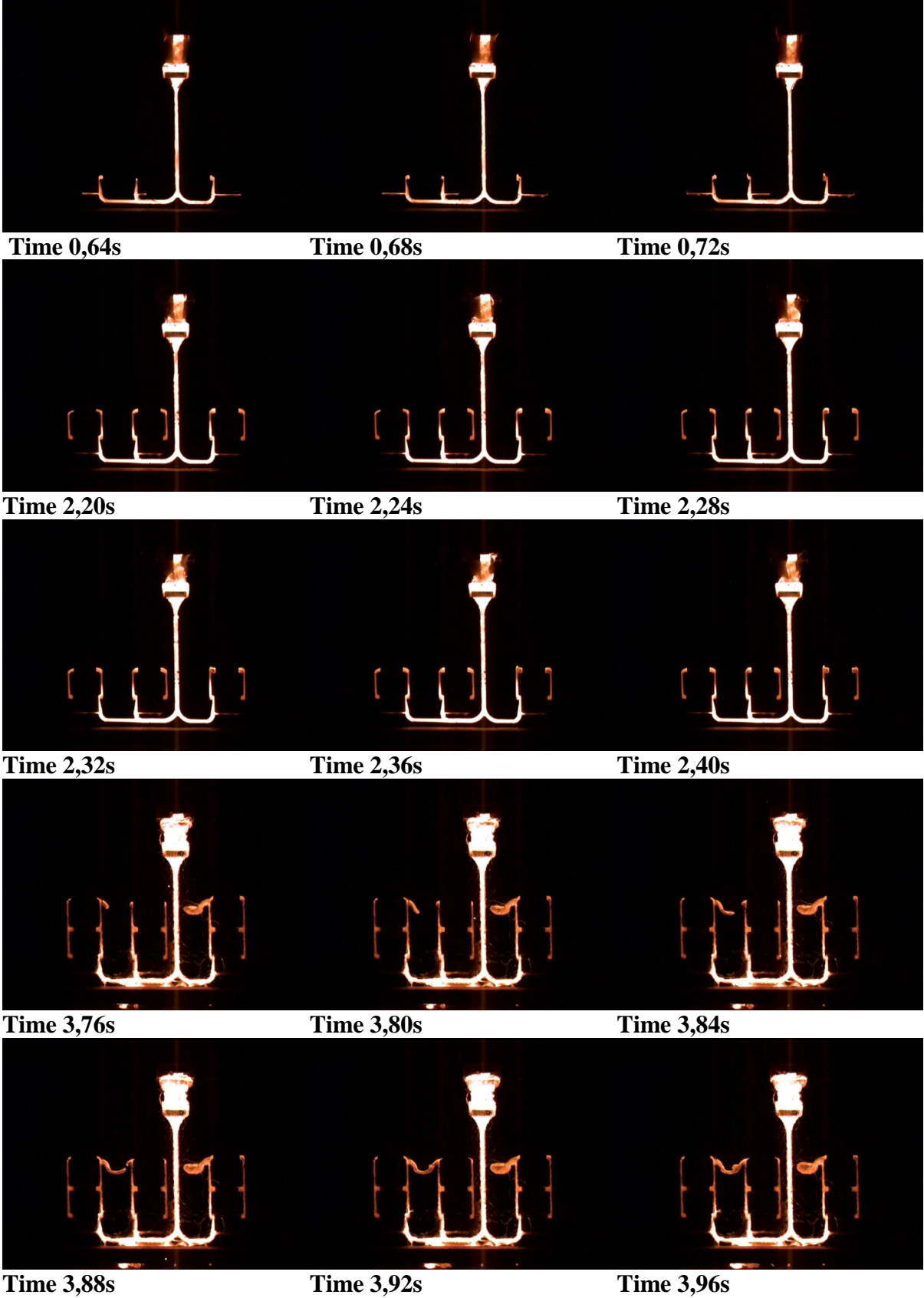


Figure 6-9 Streamlined gating system. A pressed filter is used.

### 6.4.2 Flow pattern

The mould filling time in these experiments was found to be between 4 and 6 seconds. This corresponds very well with the pouring time of 4.1 seconds for the entire mould. It should be taken into account that some of the glass plates break during the filling so that some of the melt is spilled which of course prolong the filling time.

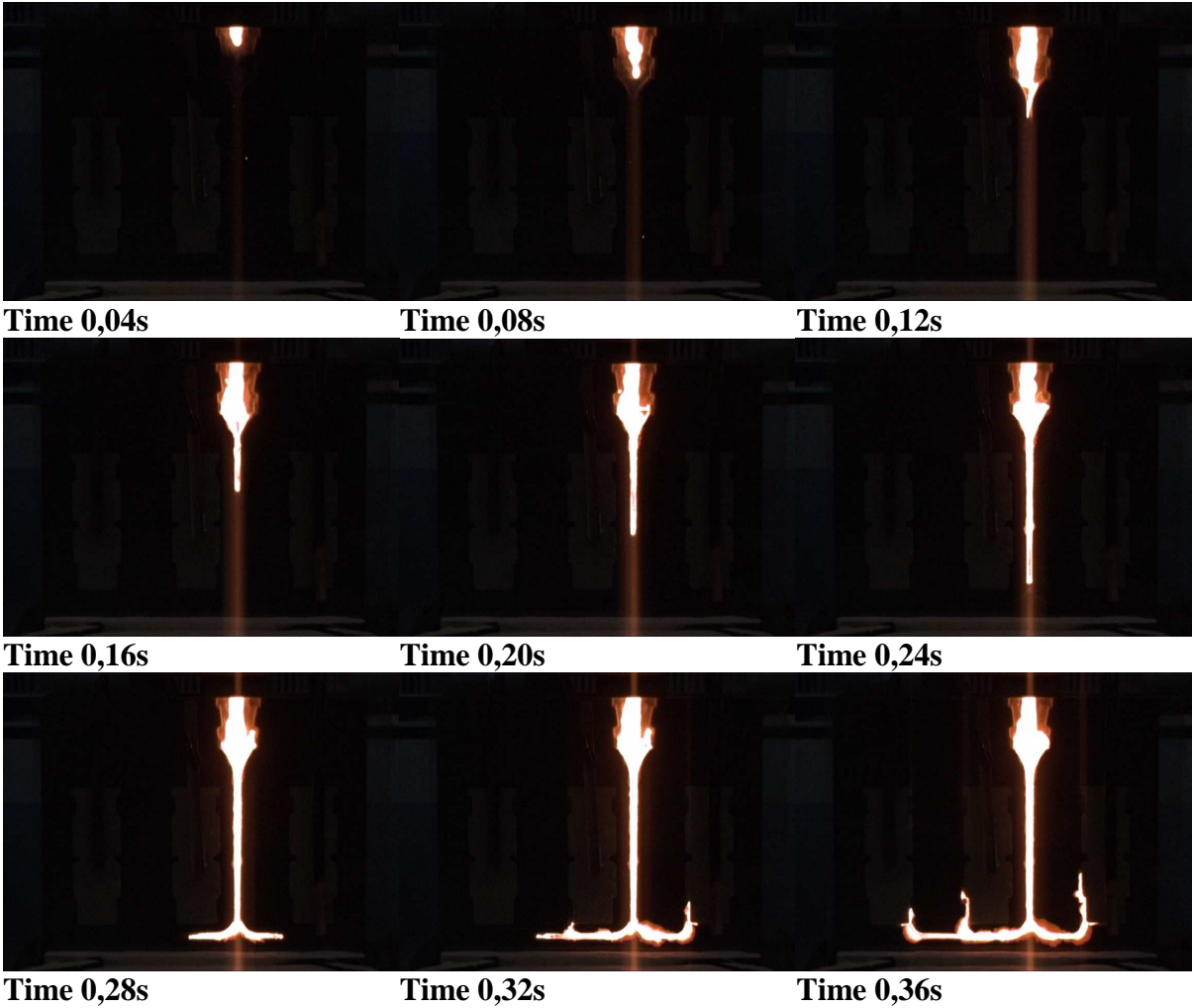
In the results presented here for the streamlined gating system using a pressed filter it is observed that the filter is preventing the flow of metal to an extent that the down runner and the funnel is not kept full until the time of 2,32s. The filter also prevents having a coherent melt front under the filter. The experiments have been repeated but this time without the use of filters. The beginning of one of these experiments can be seen in Figure 6-10. The full set of results can be seen in Appendix 2 – 14.2.2. The results with no filter show that the melt has reached the centre flange in all three castings after 1,20s. In the experiments using the pressed filter it takes 2,32s for the melt to reach the same level. This is at the same time as the down runner and funnel is back filled as mentioned earlier.

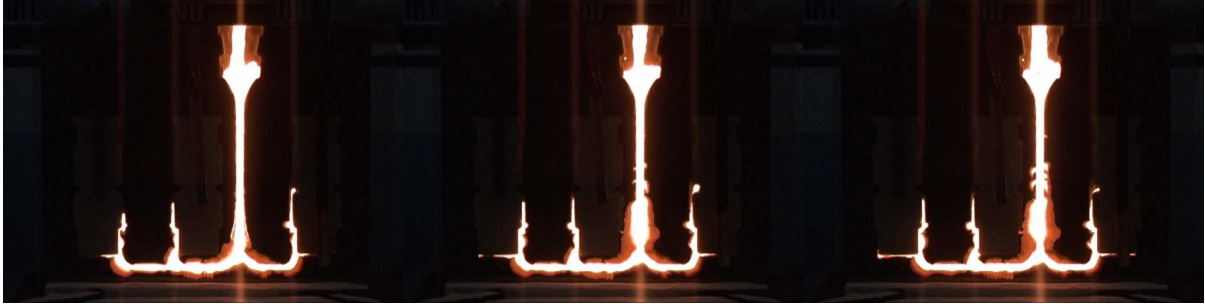
The fact that a difference in pouring time is seen in the glass plate experiments and not in the experiments in the production line can have more than one explanation. The first and most obvious is that the melt has been less clean for the glass plate experiments. Obviously this can not be ruled out completely however, the capacity of the filter should be more than sufficient. Normally it would be recommended to have a surface area between 3 and 5 times that of the system choke. [Ref. 6-2] In the streamlined layout the choke has an area of 400mm<sup>2</sup> and the filter used has a size of 60mm by 60mm having an effective area for filtration of 2500mm<sup>2</sup>. So the effective surface area for filtration is 6,25 times the cross sectional area of the system choke hence more than the upper recommendation. The use of filters will be looked at in more detail in the later chapter 'Filtration'.



Another explanation for not seeing a difference in mould filling time in the production line could be that the automatic pouring device is positioned higher above the mould than the pouring basin is in these experiments. Due to this the momentum of the melt is much higher reducing the influence of the filter on the flow of metal. The overall difference in mould filling time between the two examples shown here is only around 1,6s. Taking into account that it seems like the glass breaks earlier in the experiment using a filter, than in the experiment not using a filter, the real time difference is even smaller and probably not even noticeable in the production line.

**Streamlined Gating system – Without filter**

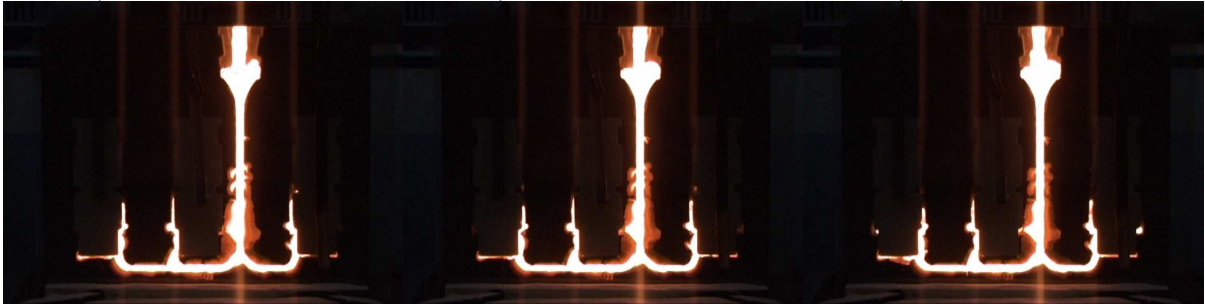




Time 0,40s

Time 0,44s

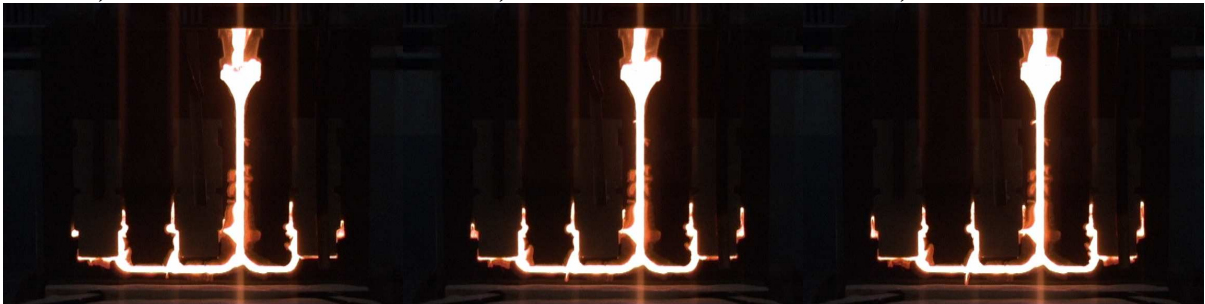
Time 0,48s



Time 0,52s

Time 0,56s

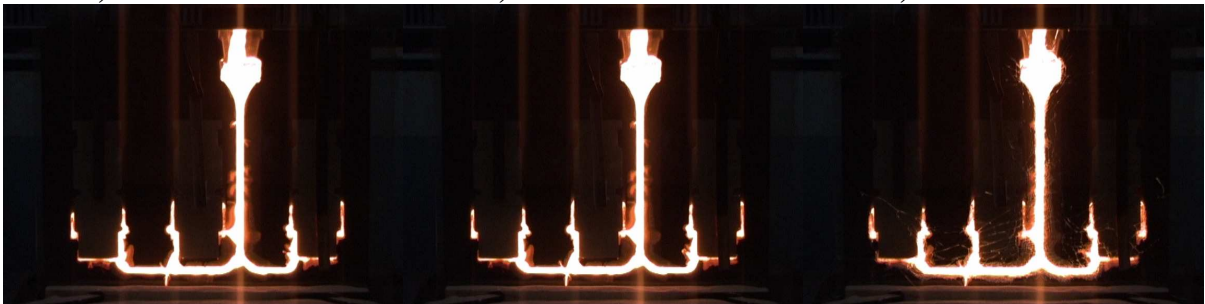
Time 0,60s



Time 0,64s

Time 0,68s

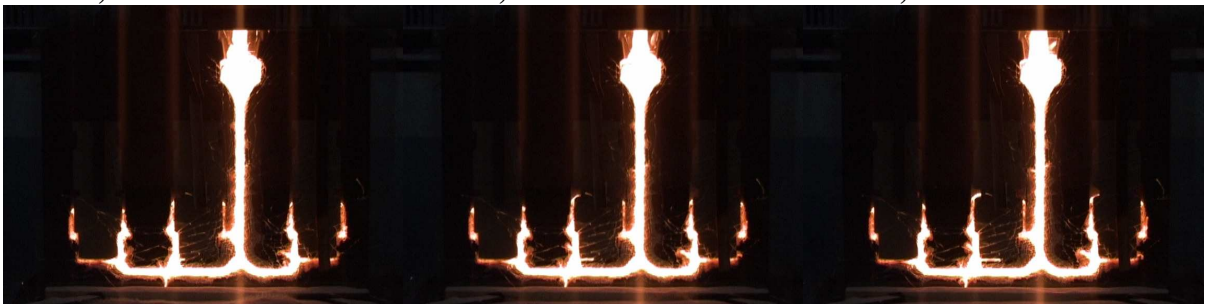
Time 0,72s



Time 0,76s

Time 0,80s

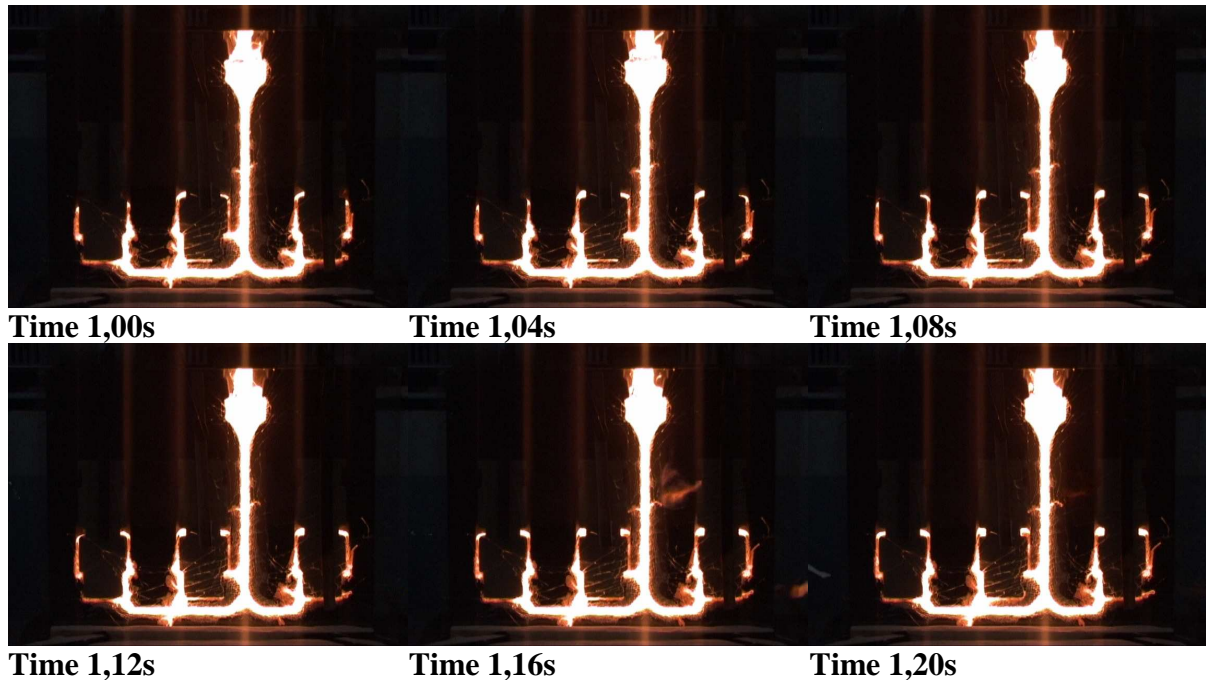
Time 0,84s



Time 0,88s

Time 0,92s

Time 0,96s



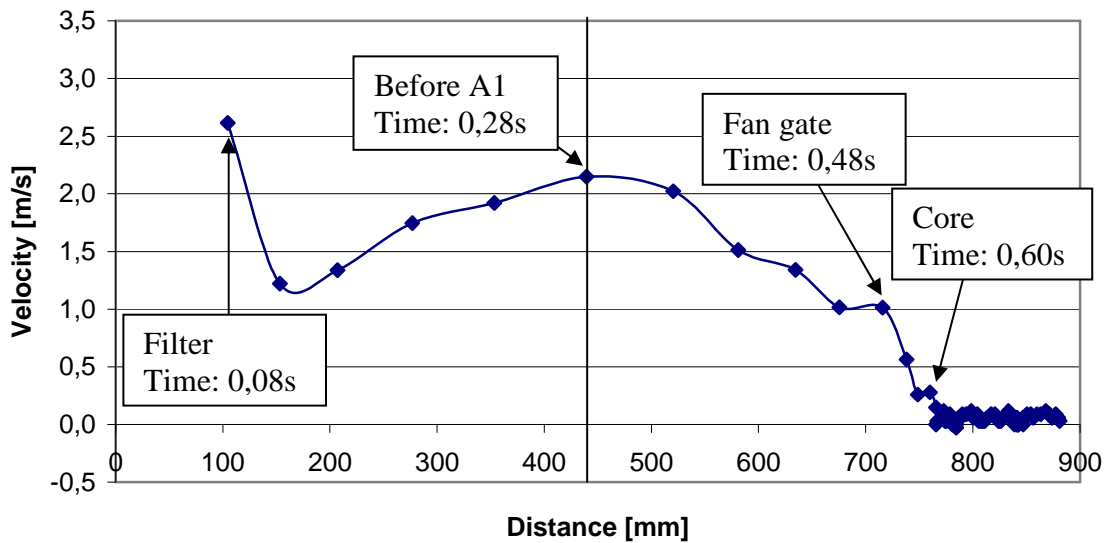
**Figure 6-10 Streamlined gating system. No filter is used**

In the glass plate experiment using a pressed filter it is seen that the filling of the castings is very calm and the melt seen on either side of the core fills up simultaneously. In the case of the experiment where no filter is used a jet of molten metal is seen on the side of the casting where the fan gate is. The splash seems to reach its maximum at 0,44s and then it drops slightly until all of the castings is filled calm and simultaneously from 0,76s. The reason for the difference in the flow patterns in the castings between the two experiments is the difference in momentum of the melt. The backfilling of the down runner and the funnel when a filter is used means that the momentum of the melt is a lot less than in the case when no filter is used in which the gating system is kept full at all times.

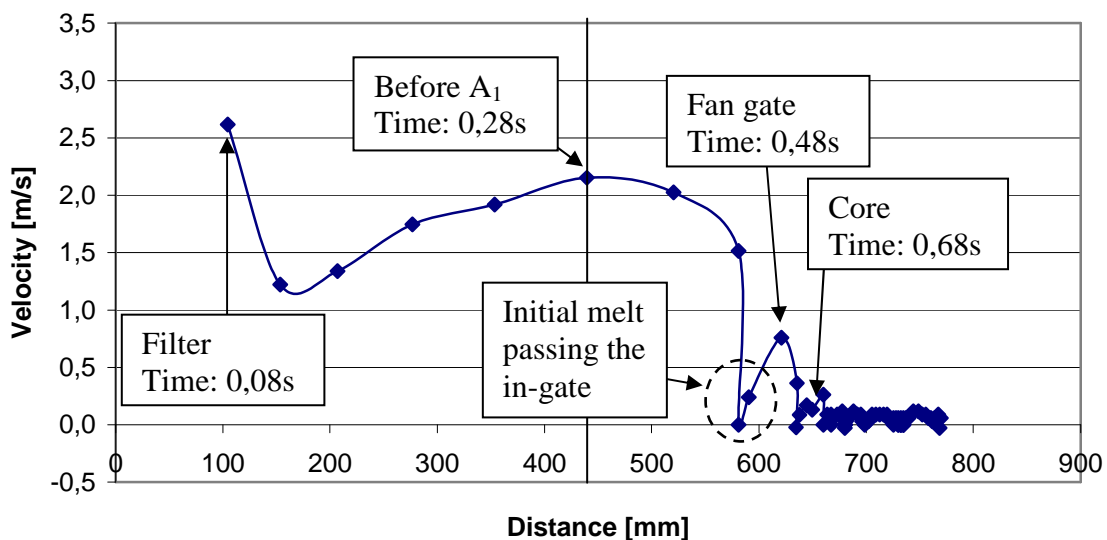
### 6.4.3 Velocities – using a pressed filter

From the experiments using a pressed filter the velocities of the front of the molten metal have been measured. This means that for each frame the distance that the very front of the melt has travelled is measured and together with the time difference between the individual frames the velocity is found. The results are divided into a graph for each of the three castings. The castings have been numbered from left to

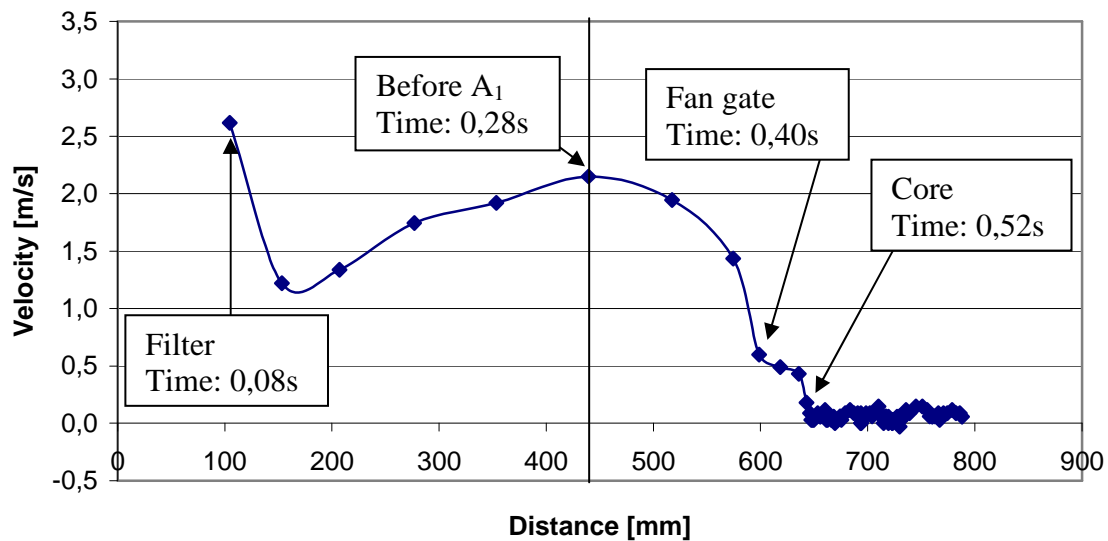
right. The velocities can be seen in Graph 6-1, Graph 6-2 and Graph 6-3. The maximum velocity for the castings is found just before the melt reaches the governing cross section called  $A_1$  in the chapter ‘Theory in gating technology’. Obviously till this point, the graphs are the same for all three castings. In the graph of casting 2 very low velocities are seen just before the fan gate. These points represent the frames where the initial melt is seen passing to casting 1.



Graph 6-1 Pressed filter - Velocities for Casting 1 (the very left in the layout)



Graph 6-2 Pressed filter - Velocities for Casting 2 (the middle in the layout)



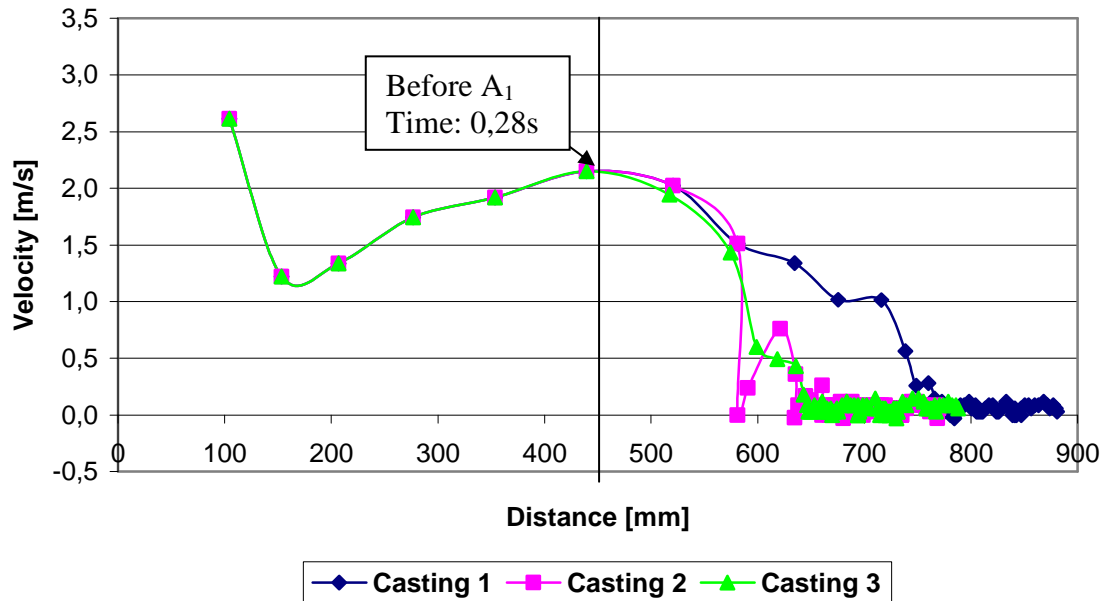
**Graph 6-3 Pressed filter - Casting 3 (the very right in the layout)**

For all three castings the velocity of the melt when reaching the fan gate is between 0,6m/s for casting 3 and 1m/s for casting 1. When the melt reaches the core the velocity is between 0,13m/s for casting 2 and 0,28m/s for casting 1. This means that for casting 1 where the highest velocities were found, from the time it reaches the fan gate and till it reaches the core, the velocity of the melt has been reduced by 72%. All three graphs reveal that the velocities of the melt when reaching the actual casting in all cases are less than 0,5m/s. For easier comparison of the three velocity profiles they are all plotted together in Graph 6-4.

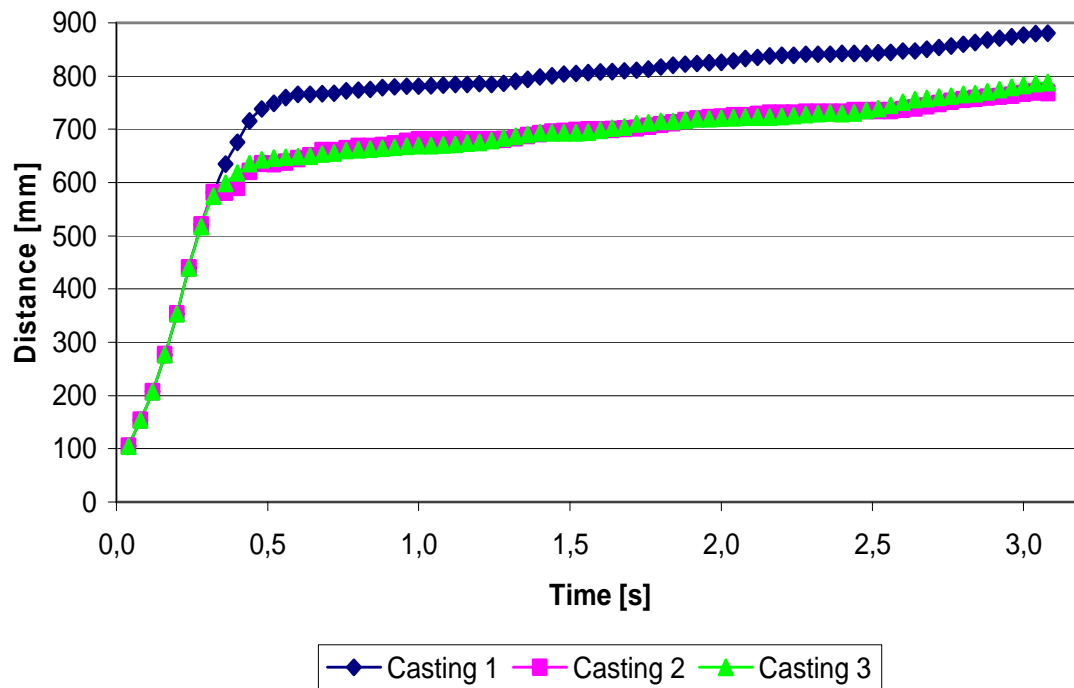
To give a better impression of how evenly the three castings are actually filled, the distance the melt has moved in the three castings has been plotted against time in Graph 6-5. In the graph it is seen that the overall rate of the filling is very similar for the three castings. The mean velocity for the three castings from the time the melt has reached the core is seen in Table 6-6.

	Casting 1	Casting 2	Casting 3
Mean velocity	0,048m/s	0,050m/s	0,056m/s

**Table 6-6 Pressed filter - Mean velocities in the three castings from when the melt reaches the core**



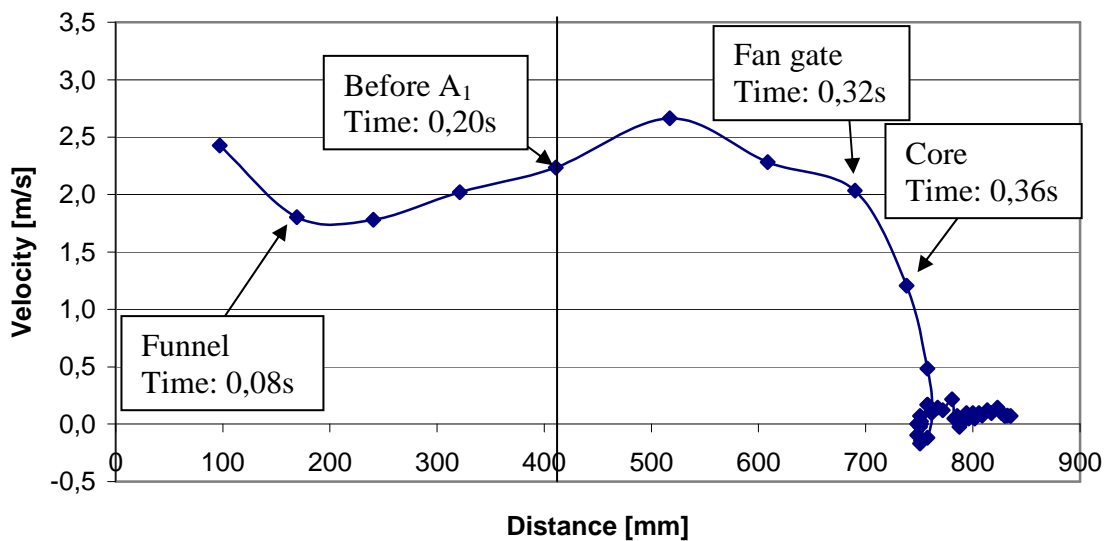
Graph 6-4 Pressed filter - The results of all three castings in the same graph



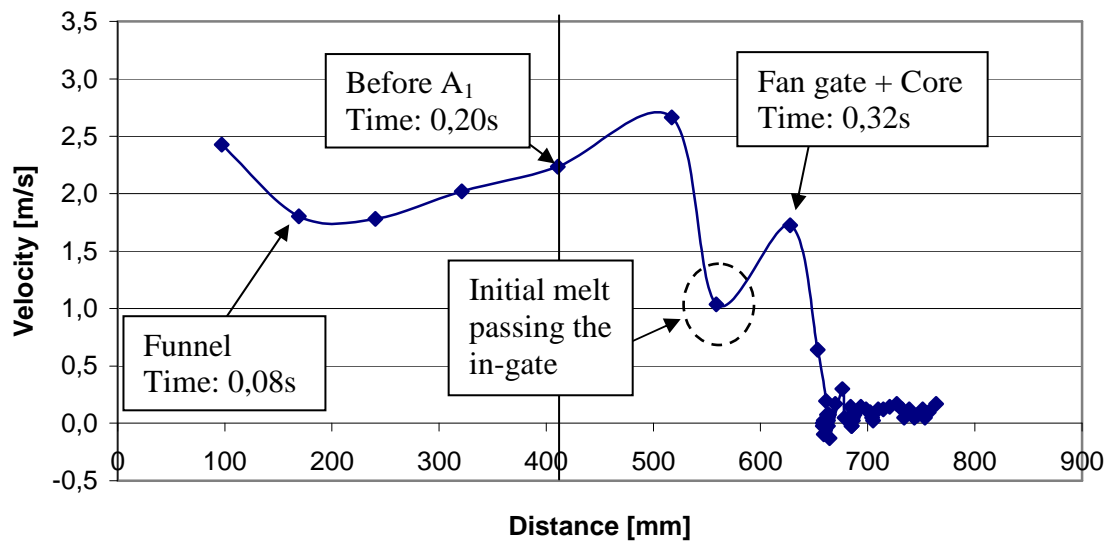
Graph 6-5 Pressed filter - The distance the front of the melt has moved plotted against the time

#### 6.4.4 Velocities – no filter

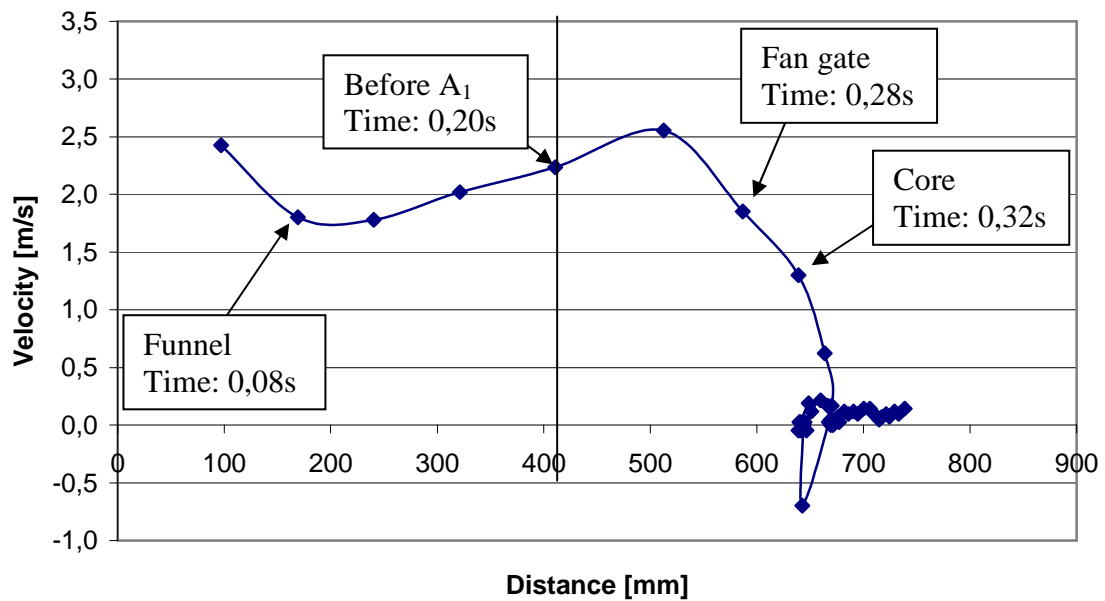
Graphs from the results of the experiments where no filters were used are presented below. In these experiments the glass starts to break very early. The flow pattern is obviously interfered by this resulting in deviations from the expected. One of these deviations occurs because the glass starts to brake after 0,64s and the melt therefore starts to fill casting 2 from the side directly from the down runner. After 0,88s the glass brakes under casting 3 letting a small amount of melt out under the core. In combination these two incidents result in a faster filling of casting 2 than casting 3. This is seen later in Graph 6-10. Due to the early braking of the glass the measurements of the front of the melt is not completed to the same extend as the results from the experiments using a filter.



**Graph 6-6 Without filter - Velocities for Casting 1 (the very left in the layout)**

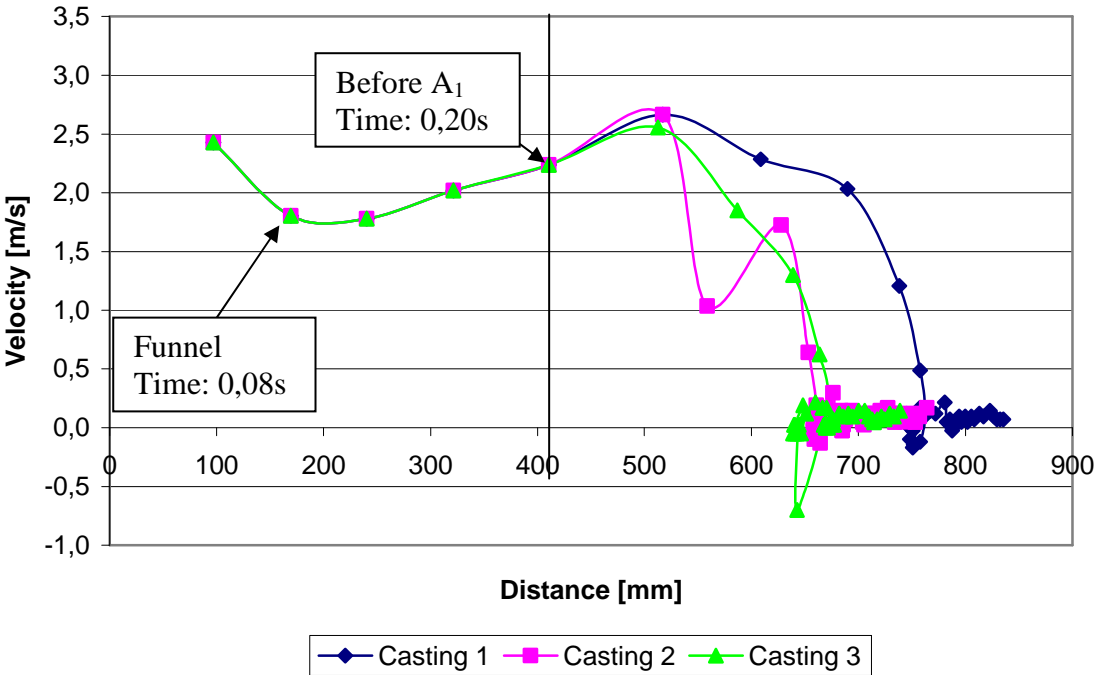


Graph 6-7 Without filter - Velocities for Casting 2 (the middle in the layout)



Graph 6-8 Without filter - Casting 3 (the very right in the layout)

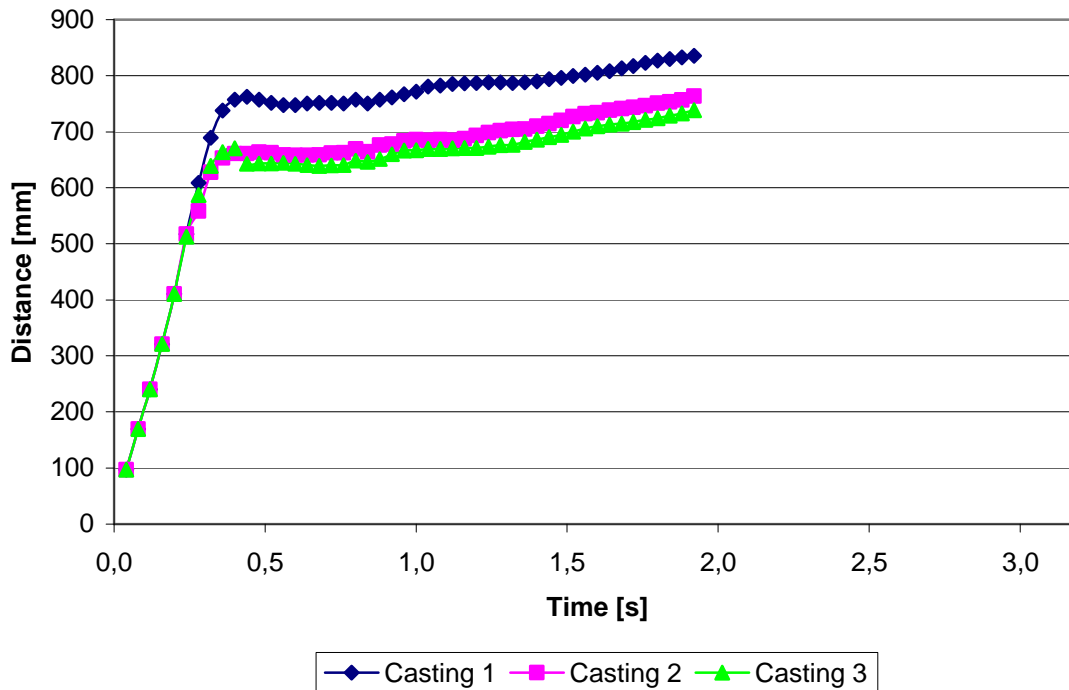




**Graph 6-9 Without filter - The results of all three castings in the same graph**

In the experiments using a filter the maximum velocity was found to be 2,2m/s just before the melt passes the governing area  $A_1$ . In the results presented here the maximum velocity is found to be 2,7m/s but here it is right after the bends under the down runner. The reason for this difference in exactly where the maximum velocity is found is, as it has been mentioned earlier the difference in momentum of the melt. The effect of this difference in momentum is also seen in the initial jets for the first melt that enters the castings. The effect of the jets is seen in Graph 6-6, Graph 6-7 and Graph 6-8 as negative values for the velocity from when the initial melt drops after the initial jet. The effect is perhaps more clear in Graph 6-10 where especially for casting 1 and casting 3 a drop in the distance is seen around the time of 0,4s. From when the melt has reached the core and onwards the mean velocities of the melt is seen in Table 6-7. These velocities are slightly higher than the mean velocities for the experiment using a filter. The high velocity of the melt in casting 2 is seen partly as a result of the earlier mentioned glass breaking. The overall lower mean velocities for the experiment using a filter is once again due to the back filling of the down runner. Having a full

gating system as in the case without a filter means a higher pressure from the melt in the down runner hence an increased driving force for filling the mould.



**Graph 6-10 Without filter - The distance the front of the melt has moved plotted against the time**

	Casting 1	Casting 2	Casting 3
Mean velocity	0,062m/s	0,085m/s	0,062m/s

**Table 6-7 Without filter - Mean velocities in the three castings from when the melt reaches the core**

### 6.5 Conclusions

The experiments proved first of all that by making a small redesign of the casting the overall poured weight can be reduced drastically by 4,2kg. However, an investigation should be done of whether or not the problem concerning feeding of the centre flange in the position of the side bar is severe enough to make a redesign of the feeders necessary. Taking this into account it is more representative to compare the weight of the gating systems meaning the total poured weight without the feeders and parts. Doing this a weight reduction of the gating system was found to be 1,1kg. The layout being for a Disamatic moulding machine producing around 350 moulds an hour means

a total saving of 385kg of iron per hour adding up to 3,08ton of iron per 8-hour work day.

A down side to the use of streamlined gating systems compared to the traditional layout was found when considering the removal of the gating system and the feeders. The change from having warm feeders to having cold feeders means an additional operation. The reason is that the round fan gates do not easily break off in the shake-out. If it had been possible to use flat fan gates the problem would have been reduced.

The streamlined gating system also gives a much better heat distribution in the castings after mould filling that eliminates the need for heat treating the casting. The resulting microstructures in the four positions of the centre flange investigated are found to be more similar than the microstructures found in the same way in the heat treated casting. The fact that a heat treatment is no longer necessary obviously means a large decrease in the energy needed for producing the valve-housings.

The pouring time for the streamlined layout was found to be 4,1s whereas the pouring time of the traditional layout is 6,5s. The pouring time is an important factor in a production line simply because if the pouring time is too long the automatic moulding machine has to be slowed down reducing the overall production capacity. This is the reason why it is important that it is proven here that it is possible to reduce the pouring time relative to the traditional gating systems.

A further benefit from the faster mould filling is the possibility of lowering the pouring temperature. The final castings in these experiments were cast at a temperature of only 1268°C. Normally cold runs would be expected in this case however the resulting castings did not show any sign of tendencies for cold running. The different ways of taking advantage of this is discussed in further detail in the chapter 'Potential energy savings'.

The experiments using glass plate fronted moulds revealed an overall calm flow pattern with or without the use of a filter in the streamlined gating system. Using a pressed filter revealed the impossibility of keeping the gating system full resulting in a reduced momentum of the initial melt entering the casting. The result was only small jets of the melt entering the castings however the overall mean velocities was also reduced relative to the experiments without a filter. The resulting flow pattern from not using a filter revealed larger jets from the initial melt entering the castings, but the gating system was kept full at all times leaving no possibility for air entrapment and oxide formation. For both sets of experiments the velocity of the melt entering the casting beside the very initial jets was well below 0,5m/s as normally recommended. All experiments here were done using ductile iron which is not normally considered very sensitive to the effects of splashes. This is also seen from the traditional layout in which the melt is allowed to drop from the height of the centre flange.

## References

**[Ref. 6-1] Henriksen F. Maskinfabrikken Dania A/S – Angående prøvebearbejdning af Ventilhus 72307. Dato 27-02-2006**

**[Ref. 6-2] Andrews I.A., Matthews A.L. – Molten Metal Filtration An Engineered Balance. Hamilton Technical Ceramics.**

## 7 Runner width

When casting ductile iron the general recommendation for the runner width in streamlined gating systems is 10mm. [Ref. 7-1] However this runner width in combination with the draft angle sets a limit to the size of the cross sectional area achievable. This limit was the main reason for having the gating system on either pattern plate in the streamlined gating system presented in the chapter ‘Casting of a valve housing’. The problem is then what to do if an even larger cross sectional area is needed so that it is not enough just to have the gating system on either pattern plates.

One way of solving the problem could be to have more than one down runner. However first of all this takes up a lot more space on the pattern plates which could be a problem. Second of all it would be a problem to design a pouring cup that makes it possible to keep more than one down runner full at all times without any problems with vena contracta. Instead of going into these solutions, experiments were done in which all the principles in the streamlined gating systems were used but the runner width was increased. The idea is to see if it is possible to exceed the recommended 10mm limit in runner width and how the resulting flow pattern will be.

### 7.1 Designing the layout

To be sure that the runner width is the governing direction for keeping the front of the melt coherent and not the runner depth, the runner depth in the governing area were chosen to be 50% larger than the runner width in this cross section. It was chosen to try to increase the runner width to 14mm instead of 10mm in these experiments. This means that the geometry of the governing area will be 14mm in width and 21mm in depth. The module pattern plates were used for the experiments to make it easier to try different gating systems if necessary. A plate-shaped geometry is used as the part to be cast. The dimensions of the casting are seen in Table 7-1. These dimensions were chosen so that the casting, fan gate, and the bend under the casting could all be within one module in the module system. The remaining parameters used for designing the

gating system are seen in Table 7-1. In this layout there is no intention of using filter. Therefore the height of the filter is set to zero. The parameters 'width' and 'depth' of the filter is only used for dimensioning the top of the funnel. In the fan gate a small expansion in cross sectional area of 9,5% is put in mainly to slow down the melt a little without exceeding the dimensional width of the casting. The layout is seen in Figure 7-1.

The suggested pouring time for cast iron is calculated by the spreadsheet to 5,3s. The chosen pouring time however is set to only 1,51s. So the pouring time in this layout should have been three and a half time more to meet the normally recommended pouring time with the traditional gating system, which the suggested pouring time in the spread sheet is based on. The pouring time is chosen to achieve the desired geometry for the governing area. It also means that these experiments really can be used also to test how the fan gate can control and guide the melt while having very high flow rates. Actually the dimensions for the resulting gating system would be as recommended if the casting had weighed around 29kg still with a wall thickness of 10mm and a recommended pouring time of 12,5s. Had the casting been that much bigger, then a much wider fan gate would also have been possible hence giving a much larger cross sectional area and a lower velocity in the fan gate.

## Design of streamined gatingsystem

Vertical moulding

### DATA

Casting:  
**Runner width 14mm**

<i>Mould</i>	Height	400	mm
	Width	500	mm
<i>Pouring cup</i>	Height	70	mm
	Depth	55	mm
	Width	80	mm
<i>Filter</i>	Height	0	mm
	Depth	50	mm
	Width	50	mm
<i>Funnel</i>	Height	40	mm
<i>Draft angle</i>		3	°
<i>Maximum runner width</i>		14	mm
<i>Rounding of bend below down sprue</i>		40	mm
<i>Rounding of bend below casting</i>		40	mm
<i>Expansion of crosssectional area in rounding below casting (only pos)</i>		0	%
<i>Height from base of mould to base of runner</i>		30	mm
<i>Length of horizontal runner</i>		180	mm
<i>Expansion of crosssectional area in horizontal runner</i>		0	%
<i>Number of mm between measurements in horizontal runner</i>		50	mm

<i>Fan gate</i>	Height	40	mm
<i>Expansion in crosssectional area</i>		9,5	%
<i>Connection with casting</i>	Width	140	mm
	Depth	2	mm

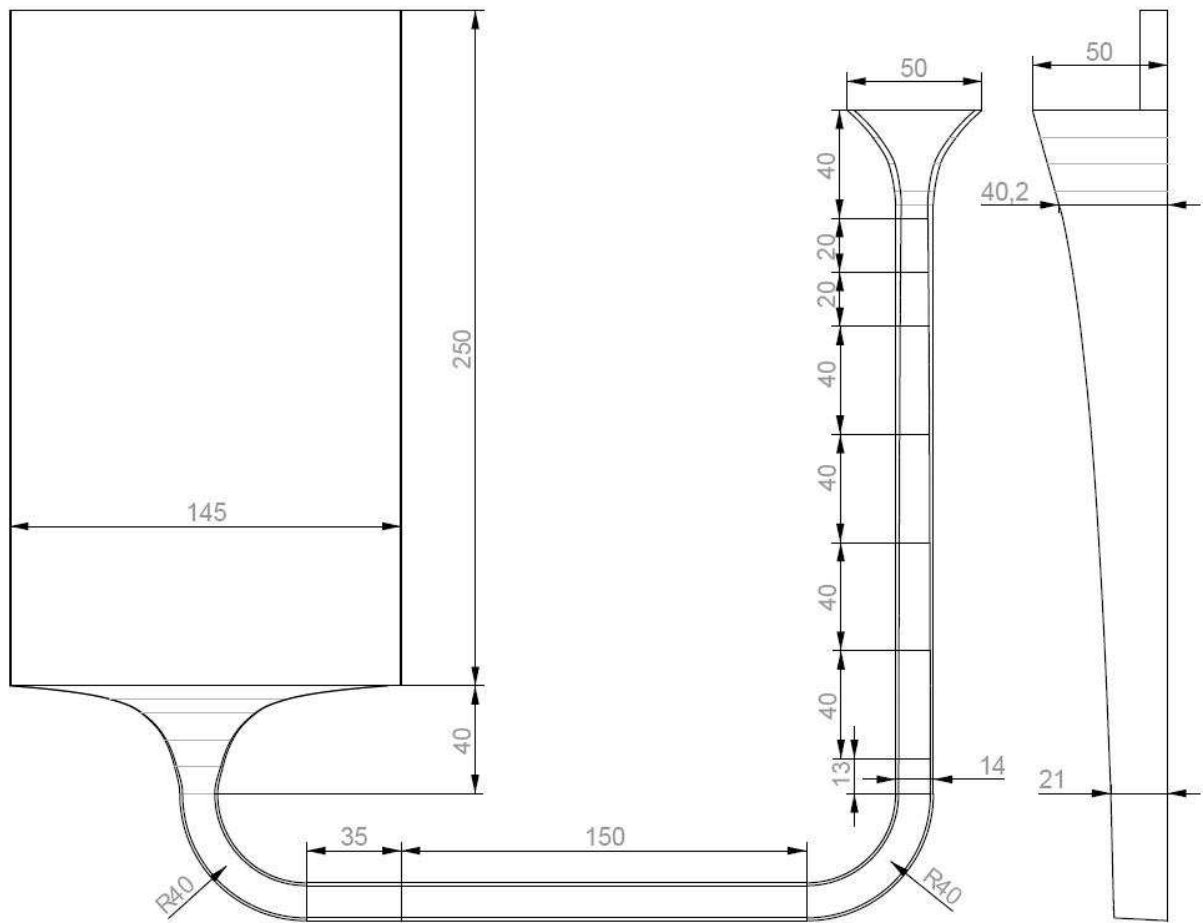
<i>Weight of casting and feeders</i>		2,6	kg
<i>Wallthickness of casting</i>		10	mm
<i>Height of casting</i>		250	mm
<i>Width of casting</i>		145	mm

<i>Estimated weight of runners</i>		1	kg
<i>Loss factor in runner system</i>	m	0,5	
<i>Density of the molten metal</i>	$\rho$	7000	kg/m <sup>3</sup>
<i>Suggestions for pouring times</i>	Cast iron	5,3	s
	Bronze	8,3	s
	Aluminium	26,7	s
	Steel	3,4	s
<i>Chosen pouring time</i>	t	1,51	sec

*Governing area (Base of down runner)* 271 mm<sup>2</sup>

**Table 7-1 The parameters used for designing the layout**

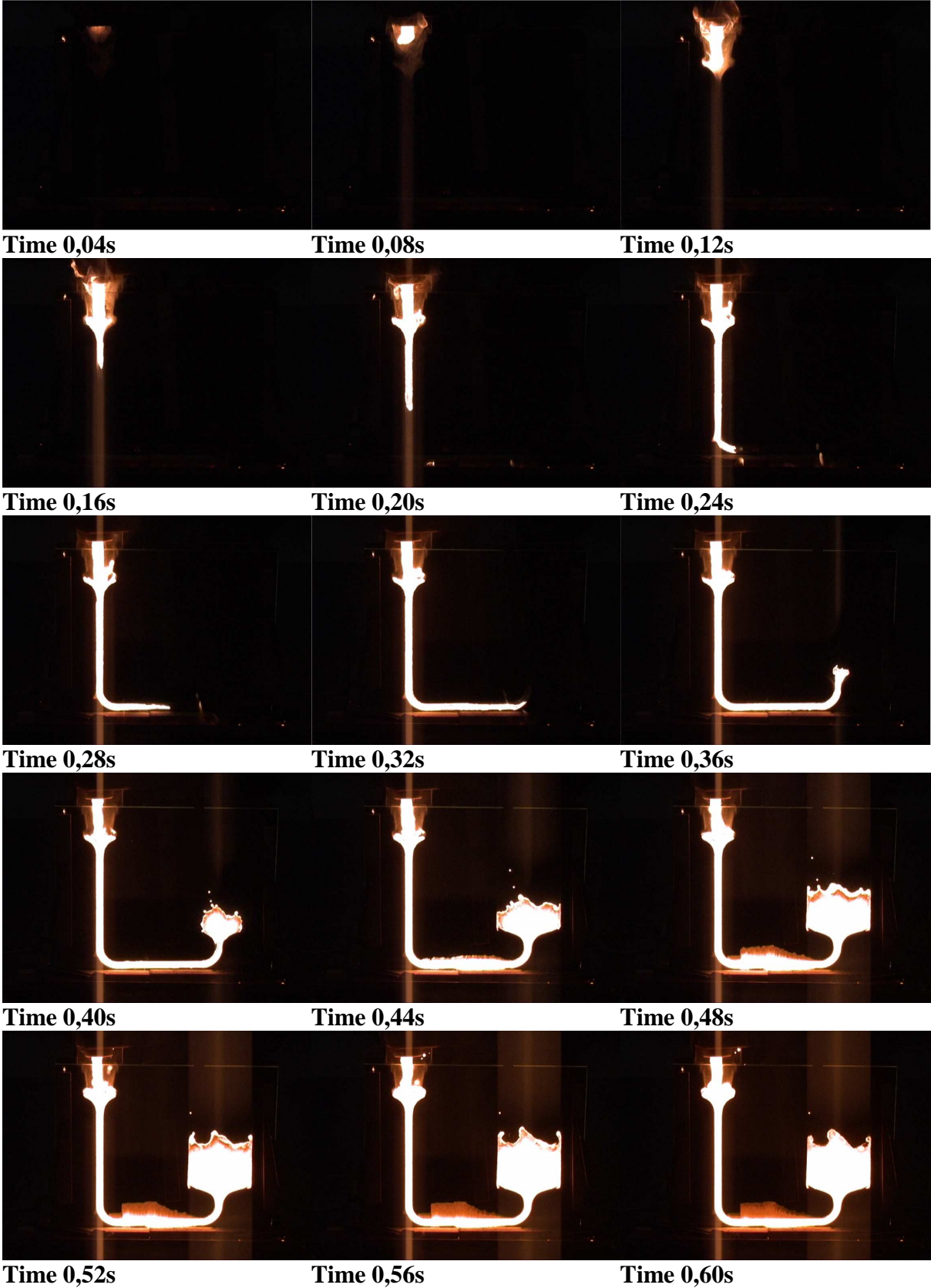


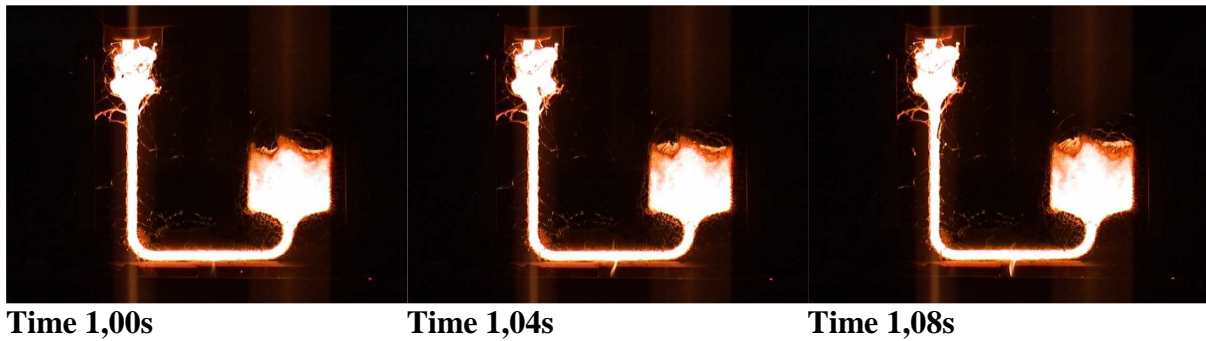


**Figure 7-1 Drawing of the layout**

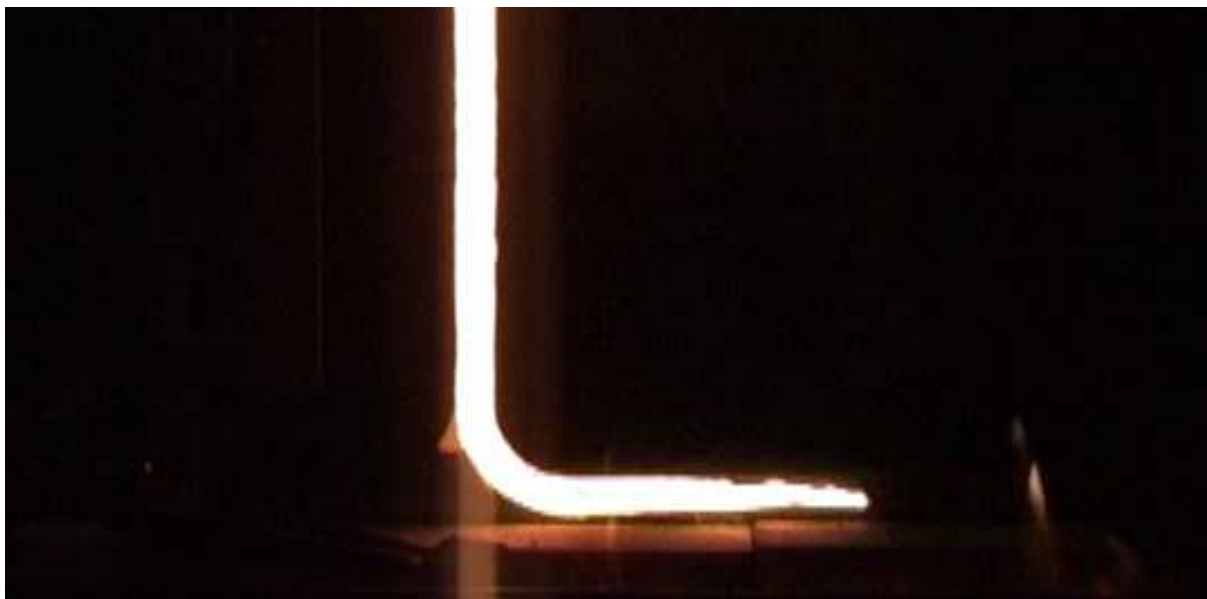
## 7.2 Results from glass plate experiments

Computer simulations have been done with this layout. The results of which were presented in the chapter ‘Simulations’. These simulations showed however that it is very difficult to achieve reliable simulation results using fan gates. However the following results from the experiments using glass plate fronted moulds can help in understanding the flow pattern of the melt through fan gates. Only part of the frames from the experiment is shown here. The full set of frames can be seen in Appendix 3 – 14.3. The films from all the experiments can be seen on the DVD.





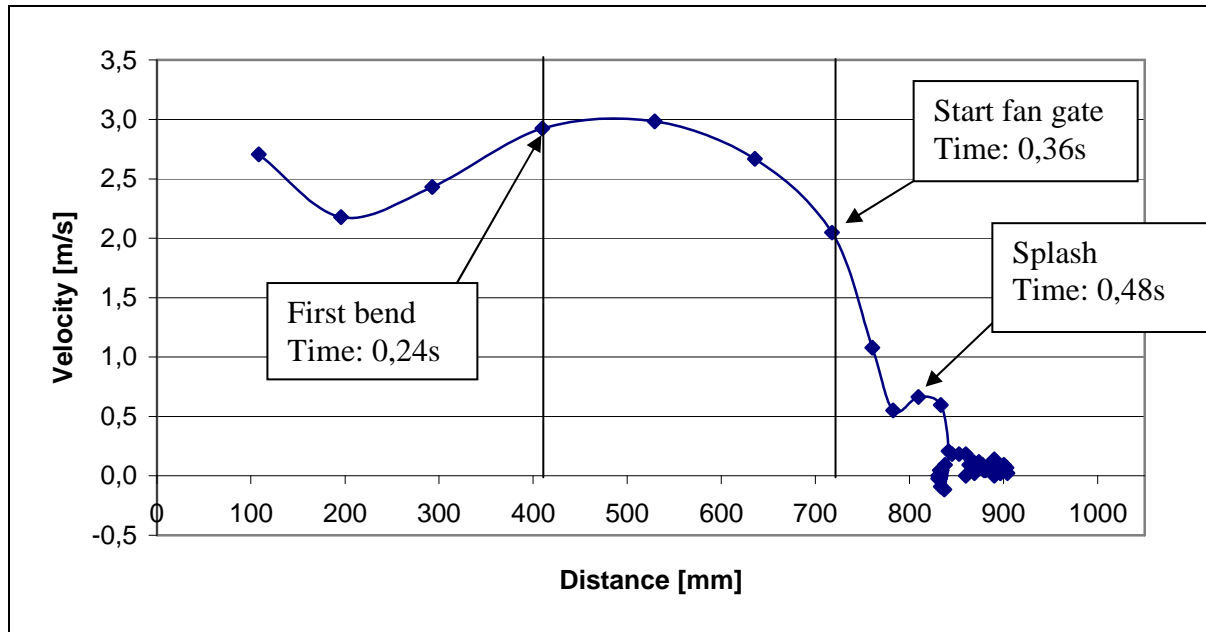
The results show that there is no problem in keeping the front of the melt coherent in the down runner. However in the horizontal runner there are indications that it is difficult to keep the runner full at all times. This is seen in the enlarged frame in Figure 7-2. The melt is kept coherent but the first melt does not fill the runner completely. However the problem is not large enough to cause any problems for the quality of the melt. The results show that having a runner width of 14mm it is still possible to keep the front of the melt coherent.



**Figure 7-2** The frame shows the front of the melt in the horizontal runner. The time for the frame is 0,28s.

As mentioned the gating system used in these experiments results in a very short pouring time for the 10mm plate. This means also that it is tested how well the fan gate is at confining and controlling the melt flow. The results show that the very first melt

to enter the casting forms a thin jet foil in the entire width of the fan gate. Then the remaining melt fills the casting behind this thin plate of metal from the initial jet.



**Graph 7-1** The graph show the measured velocities through out the mould filling

Graph 7-1 shows the velocities throughout the mould filling. As it would be expected the melt accelerates through the down runner. After the first bend the melt is no longer accelerated and a maximum velocity of around 3m/s is reached in the first part of the horizontal runner. The largest deceleration of the melt happens in the fan gate. Passing through the fan gate the melt decelerates from 2m/s to 0,5m/s. After the initial jet the velocity is only in average 0,083m/s for the remaining of the filling.

### 7.3 Conclusions

The results from these glass plate experiments show that it is possible to have a larger runner width than the 10mm recommended. Only small tendencies of problems are seen in these experiments due to a runner width of 14 mm. The front of the melt is still coherent in all of the gating system but there are small difficulties in keeping the cross section of the runner completely full at the melt front. Further studies need to be done to see if more severe problems will occur if the runners are made even wider. One should bear in mind that the problems of having a runner width limited to 10 mm most

likely occur in the very top of the down runner. The results here show that there is no problem in keeping the down runner full having a runner width of 14mm. Therefore, in case a runner width of 10mm is not enough for the top of the down runner it is recommendable that the runner width should be decreased passing from the down runner to the horizontal runner.

## References

**[Ref. 7-1] Larsen, Per – Iron Melt Flow in Thin Walled Sections Cast in Vertically Parted Green Sand Moulds. Technical University of Denmark 2004**



## 8 Filtration

### 8.1 The reasons for discussions

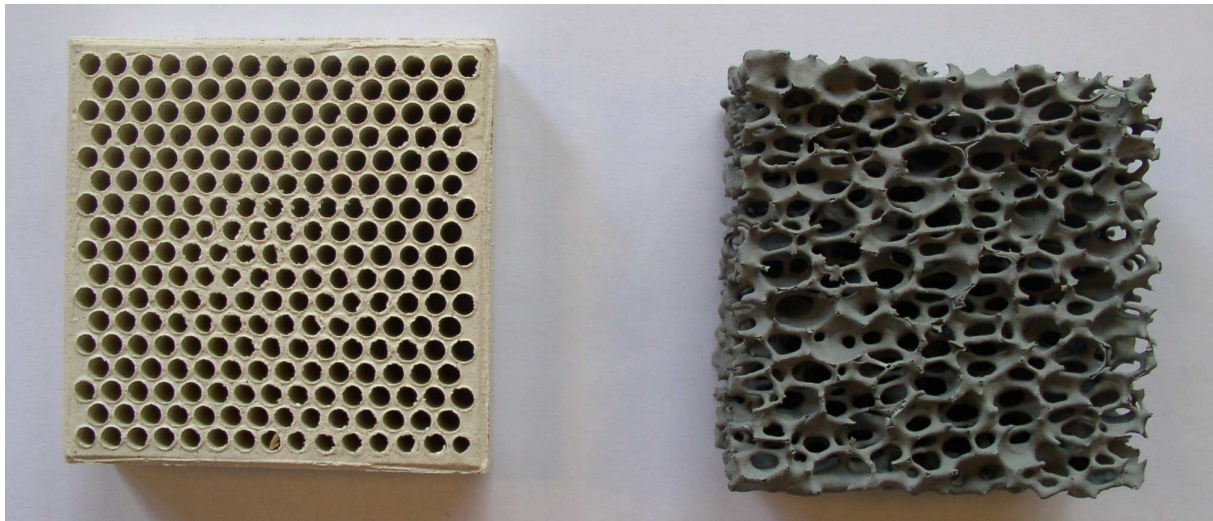
When designing the layout of gating systems one of the major subjects for discussion is filtration. The reason for this discussion is that not everyone agrees on the benefits of using ceramic filters and on whether or not filters should be used in the first place. The first and most obvious reason for using filters is for filtration of the molten metal. This means that filters are to be used as early as possible in the gating system in order to remove slag and dross from the molten metal. The second major reason is that the filters help to achieve a controlled and calm filling of the casting. The filter is supposed to not only help avoiding inclusions in the casting but also reduce the velocity of the melt and, give a coherent flow of melt and hence a calm filling of the casting. This means that the filter should be placed as late as possible in the gating system. Because of this disagreement on the very basic for the use of filters further related discussions often erupt as well. There are different kinds of filters so there is a discussion on which type is the best. Another discussion is about exactly how the filter should be placed in the mould, and especially if the filter should be placed at the top or at the lower part of the mould.

The solutions on how to place a filter have one thing in common. An expansion of the gating system is necessary on either side of the filter. Examples of this are shown below in the passage 'Filter prints'. In this way placing a filter in the mould also increases the poured weight. Since the goal in this project is to try to minimize the amount of metal to be re-melted a closer study on filtration has been done to see if savings are possible. This study can also help answering many of the above described questions concerning filters.



## 8.2 The different kinds of filters

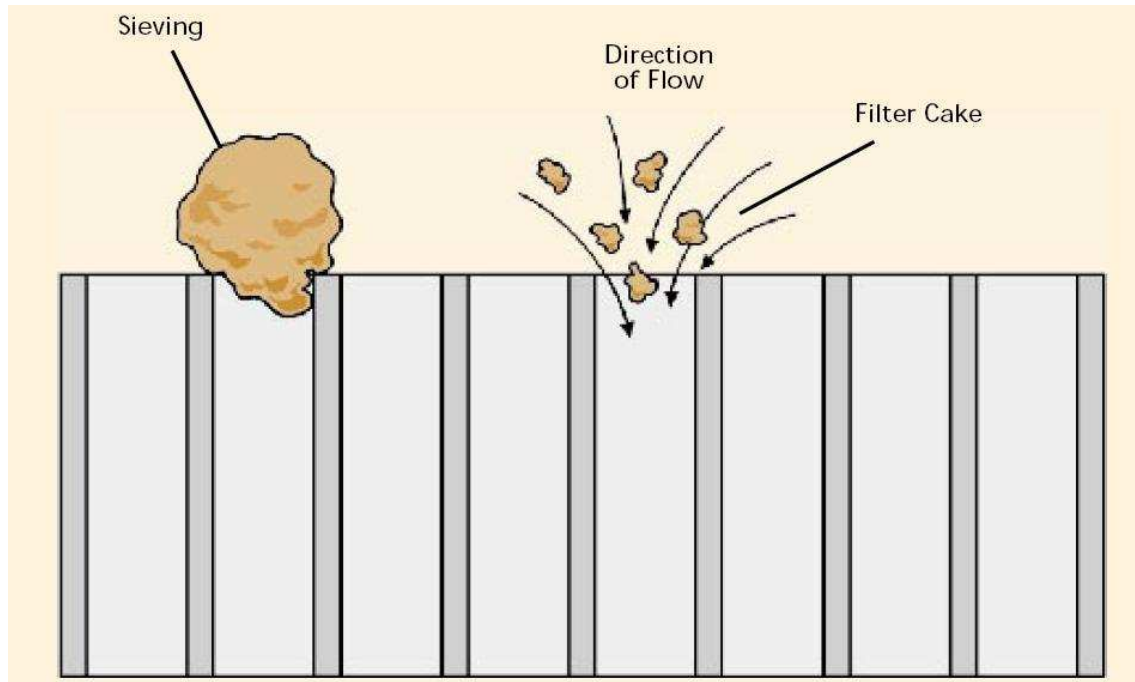
There are different kinds of ceramic filters but only the two most predominantly used by the foundry partners in this project are studied in the following. These are pressed filters and foam filters as shown in Figure 8-1. All the experiments in this study have been done using ductile iron and the filters have been chosen according to the recommendations from the filter producers.



**Figure 8-1 Ceramic filters. To the left: a pressed filter, size: 50mm x 50mm, diameter of the holes: 2,4mm. To the right: a foam filter, size: 50mm x 50mm, porosity: 10ppi (pores per inch)**

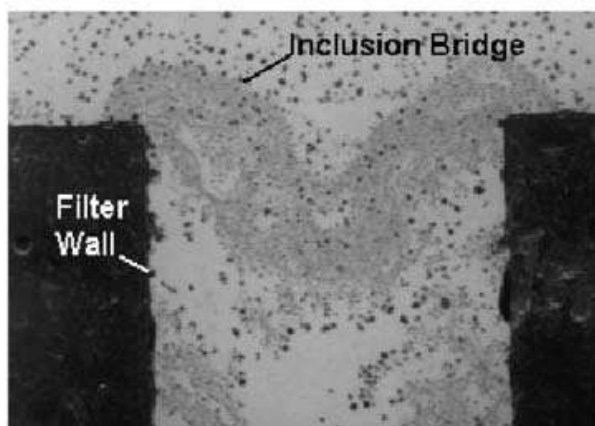
## 8.3 Mechanisms in filtration

The filtration of the melt using pressed and extruded filters works involving three mechanisms. The first mechanism is ‘Sieving’ in which all particles too large are mechanically prevented from passing through the filter. The second filtrations is ‘Cake filtration’ in which particles build on the surface of the ceramic filter becoming a filter in itself. The third mechanism is ‘Deep bed filtration’ in which the very small particles having very high surface energies are attracted to the inside surfaces of the filter and a sintering action occurs. [Ref. 8-1] [Ref. 8-2] The mechanisms are illustrated in Figure 8-2.



**Figure 8-2 [Ref. 8-1] Mechanisms in filtration**

Figure 8-3 illustrates the filtration effect of the filter cake. The figure shows a micrograph of the entrance face of a filter in ductile iron. The hole in the filter has a diameter of 2,3mm. The filter cake is clearly seen as micro inclusions from mainly MgO and MgS form a bridge across the hole in the filter. [Ref. 8-3]

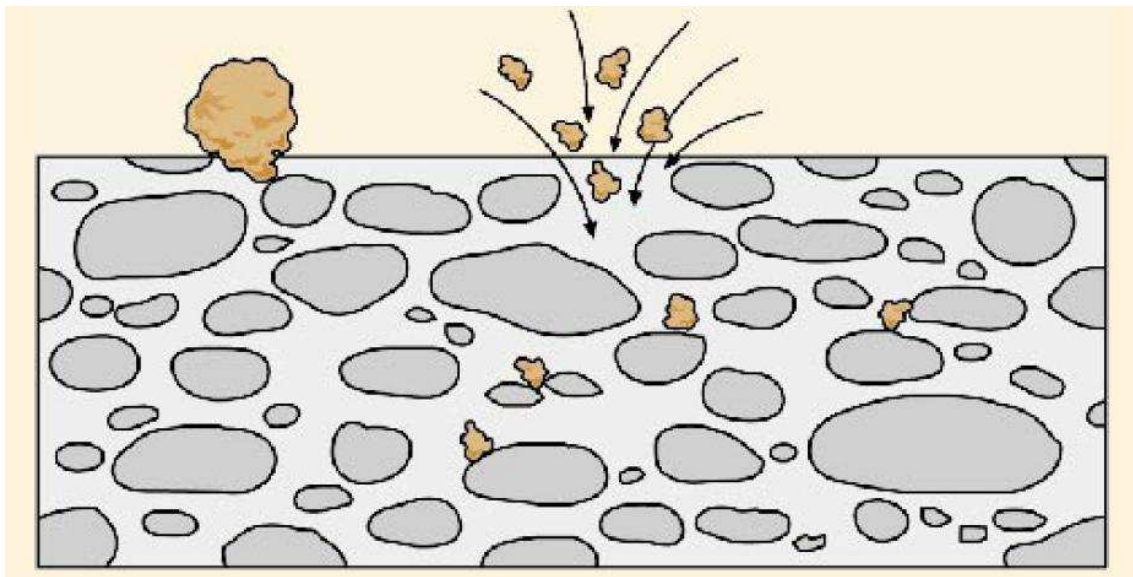


**Figure 8-3 [Ref. 8-3] Micrograph of an inclusion bridge**

That the micro inclusions stopped by the filter mainly are MgO and MgS particles is not necessarily positive. The reason is that especially these particles act as nucleation sites for graphite nodules in ductile iron. This means that the filter actually might

decrease the inoculation of the melt in the casting during solidification. [Ref. 8-4] Cake filtration is a filtration function that builds up gradually so the first melt and thereby the first particle that reaches the filter can pass the filter relatively easy. Therefore cake filtration is not a guarantee that all smaller inclusions are stopped in the filter.

The mechanism in filtration is different in foam filters. The mechanisms ‘Sieving’ and ‘Cake filtration’ are similar. The further description of the mechanism is: ‘*Foam filters rely upon specific density differences between inclusions and the metal as well as hydrodynamic effects such as eddy currents to increase the likelihood of particles smaller than the pore size remaining in the filter.*’ [Ref. 8-1] An illustration of the mechanisms in the foam filters is seen in Figure 8-4.

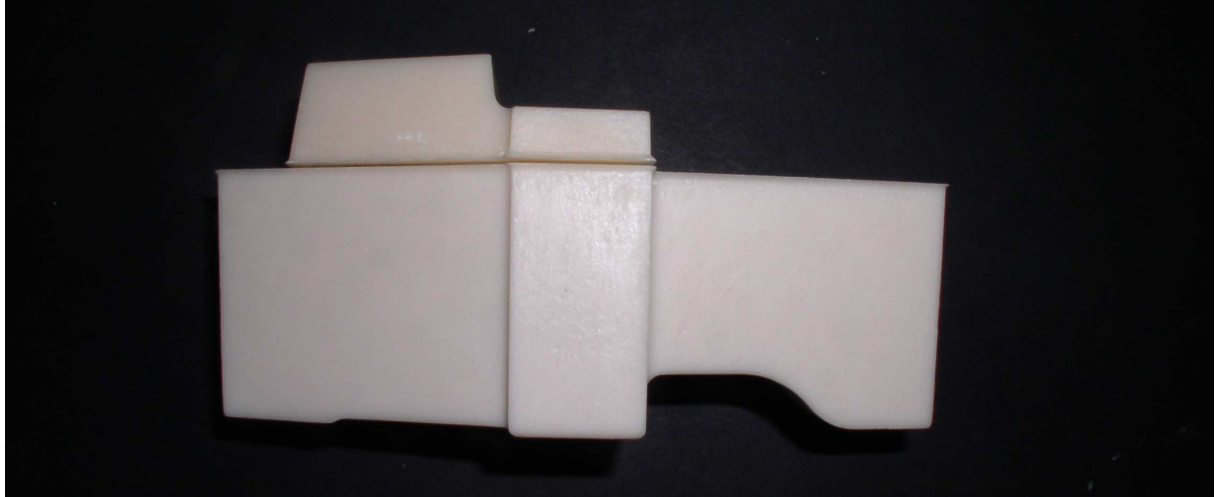


**Figure 8-4 - [Ref. 8-1] Mechanisms in filtration using foam filters**

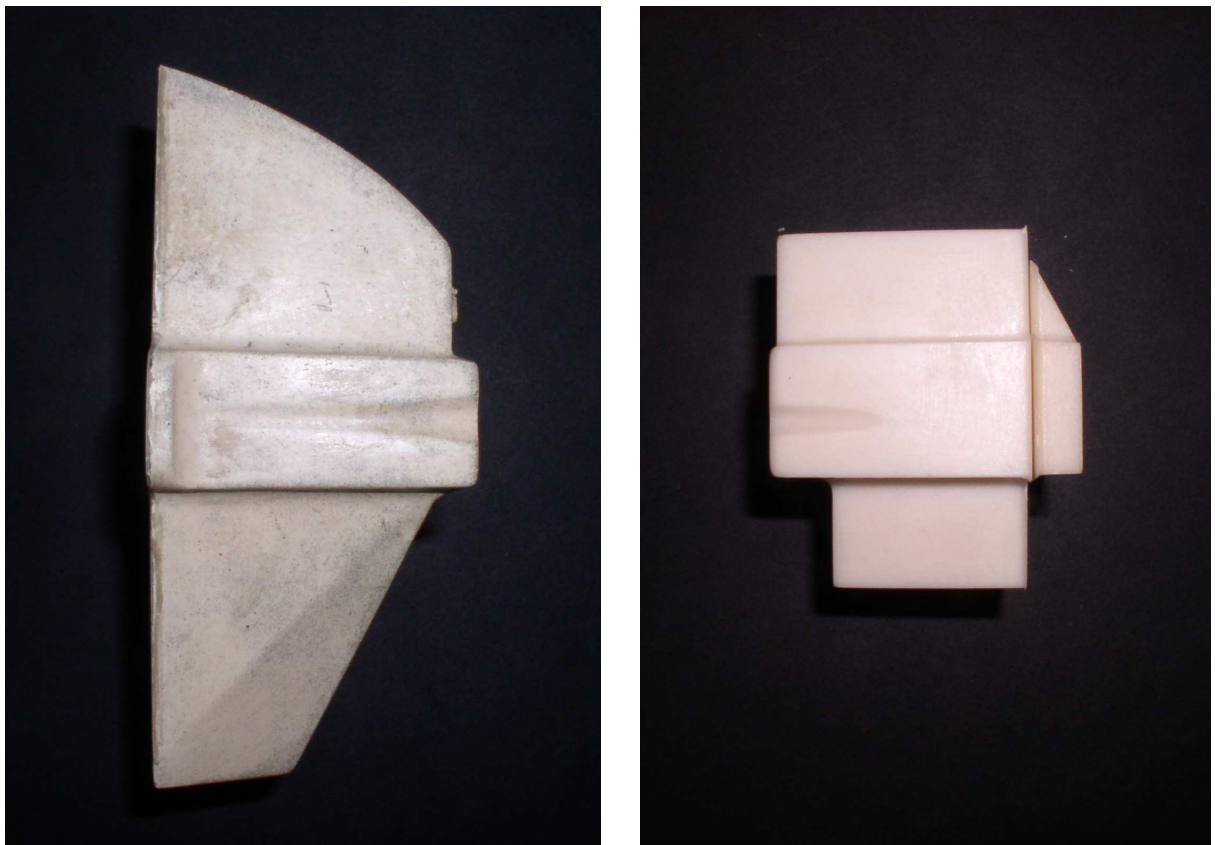
### 8.4 Filter prints

The producers of filters have a series of filter prints for the pattern plate for placing the filters in the mould. These are made to make it easier for foundries to position and use the filters according to the recommended guidelines. These filter prints are often changed slightly though and individualized for the specific foundry. For the study of flow through filters three such filter prints have been tested. These filter prints are seen

in Figure 8-5 and Figure 8-6. All of the filter prints are designed to be used with a 50mm by 50mm foam filter as seen in Figure 8-1.



**Figure 8-5 Replica of a filter print for horizontal moulding.**



**Figure 8-6 Filter prints for vertical moulding. To the left: Filter print as seen in the traditional layout presented in 'Theory in gating technology'. To the right: Replica of a filter print.**

A filter print for horizontal moulding is seen in Figure 8-5. The basic idea behind this layout is that the filter is placed vertically in the horizontal runner. The filter print should be placed so that the flow comes in from left to right. The cross-sectional area of the entrance surface is much larger than the cross-sectional area of the exit surface. The meaning is in this way to try to benefit from that in foam filters the melt flows perpendicular but also parallel to the filter. This supposedly gives a better filtration of the melt and an even more controlled flow from the exit surface.

In the pressed filters the melt obviously only flows perpendicular to the filter. The filter print seen to the right in Figure 8-6 is for use in the down runner in a vertically parted mould. Also in this filter print the cross-sectional area of the exit surface is a lot less than the area at the entrance surface. The filter print to the left in Figure 8-6 is the one used in the traditional layout as described in the chapter 'Theory in gating technology'. This filter print can be used for both foam filters and pressed filters since the entrance area of the filter is the same as the exit area.

When using filters it is important to remember that it is difficult for the manufacturers of filters to produce especially foam filters to the exact specified dimensions. This means that foam filters always are smaller than they should be in order to fit in the mould on all occasions. At the same time the filter prints are always made slightly larger than the specified filter. Combined this means that there may be a gap of at least 2-3 millimetres in total between the filter and the mould. Filter prints are by necessity always made with a draft angle but the filters are not. This means a further increase in the gap between the mould and the filter letting melt circumvent the filter. Even though it means that filters can be placed the wrong way it is still a recommendation to produce the filters with the same draft angle as the filter prints if not all filters then at least for the larger filters.

## 8.5 Glass plate experiments

To investigate the flow of molten metal through filters using the different filter prints presented above a series of glass plate experiments have been conducted. The filter prints have all been modified slightly so that the layout is on only one pattern plate. This is necessary for the glass plate experiments. An example of these modifications is seen in Figure 8-7.

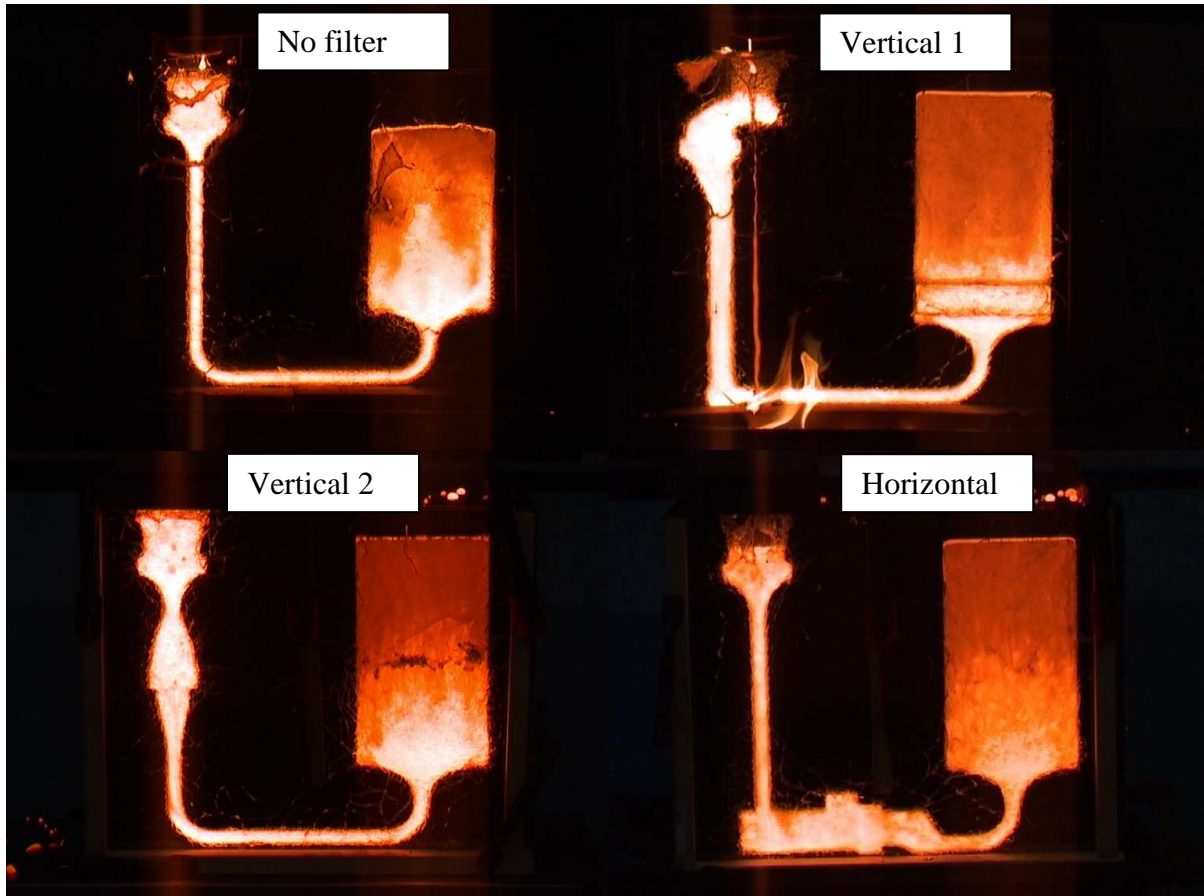


**Figure 8-7** The picture shows an example of how the filter prints have been slightly modified to do the glass plate experiments. In the original use of the filter print shown here the parting line would have been perpendicular to how it is used here.

### 8.5.1 The different layouts

The three filter prints have been tested against the layout with no filter used in the chapter ‘Runner width’. For all of the four different layouts the module pattern plates described in the passage ‘Experimental facilities – Facilities at DTU’ was used. This means that the module with the plate shaped casting; the fan gate and the bend under the casting are used for all layouts. The remaining two modules for the pattern plate are changed for the different layouts and filter prints. The gating systems have all been designed to resemble the type of gating system that the filter prints are designed for.

Figure 8-8 shows a frame from the end of the filling from all four layouts. In this way the differences in the layouts can be seen. In the layout 'Vertical 1' in Figure 8-8 a small 4 mm thick glass plate is positioned in the casting 4mm above the fan gate. This was done to see the effect of the flow pattern of the melt in the casting and especially the effect on the initial thin jet of melt seen in the experiments regarding runner width.



**Figure 8-8** The four different layouts. Top left: layout with no filter. Top right: layout with the filter print from the traditional layout presented in the chapter 'Theory in gating technology'. This layout is called 'Vertical 1'. Lower left: Filter print for vertically parted moulds. This layout is called 'Vertical 2'. Lower right: Filter print for horizontally parted moulds. This layout is called 'Horizontal'.

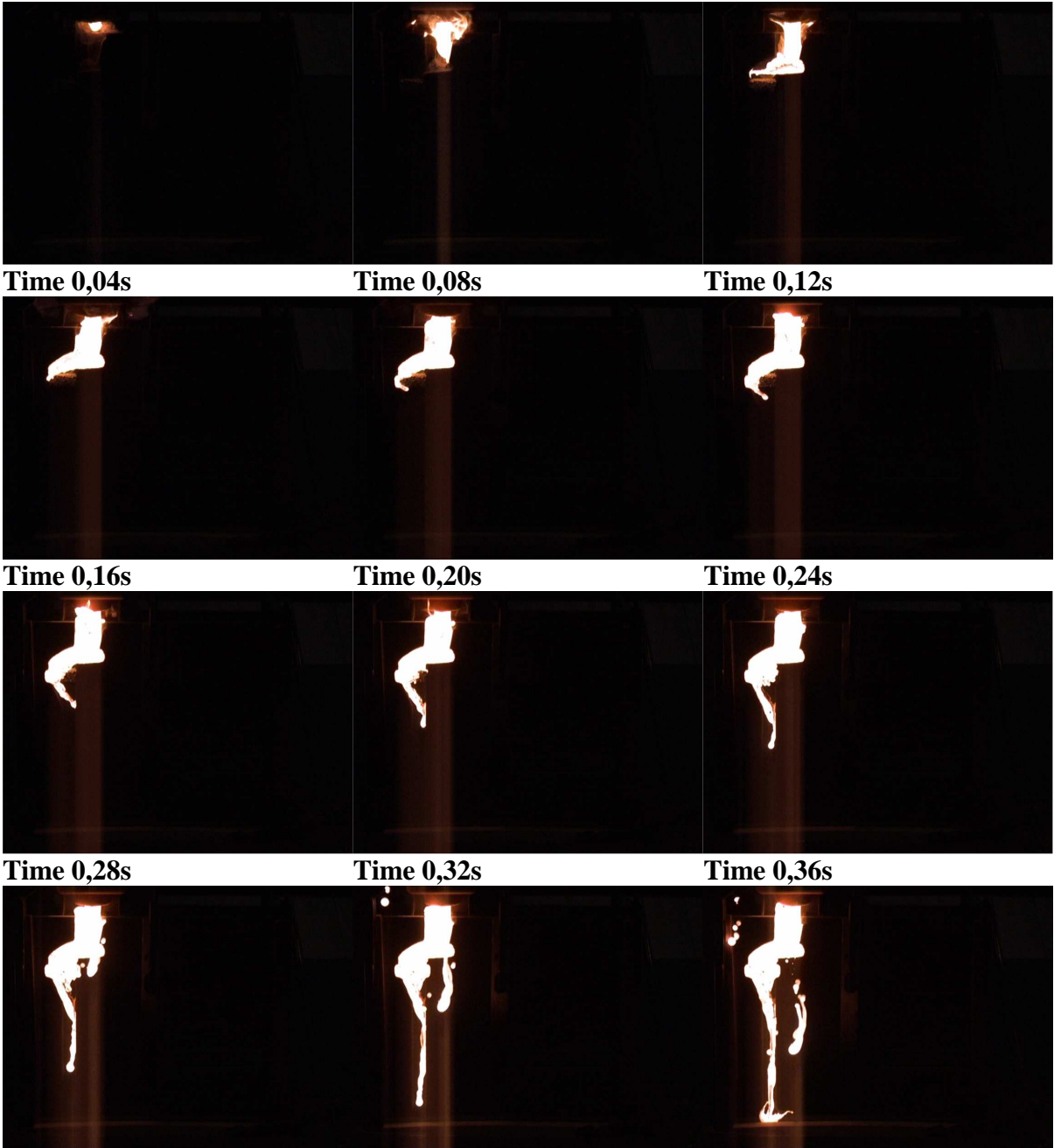
## 8.6 Results from the glass plate experiments

The investigation of the results is divided into two. First the flow patterns for the mould fillings are examined and then the first melt to pass through the filter is examined. The films from all the experiments can be seen on the DVD.

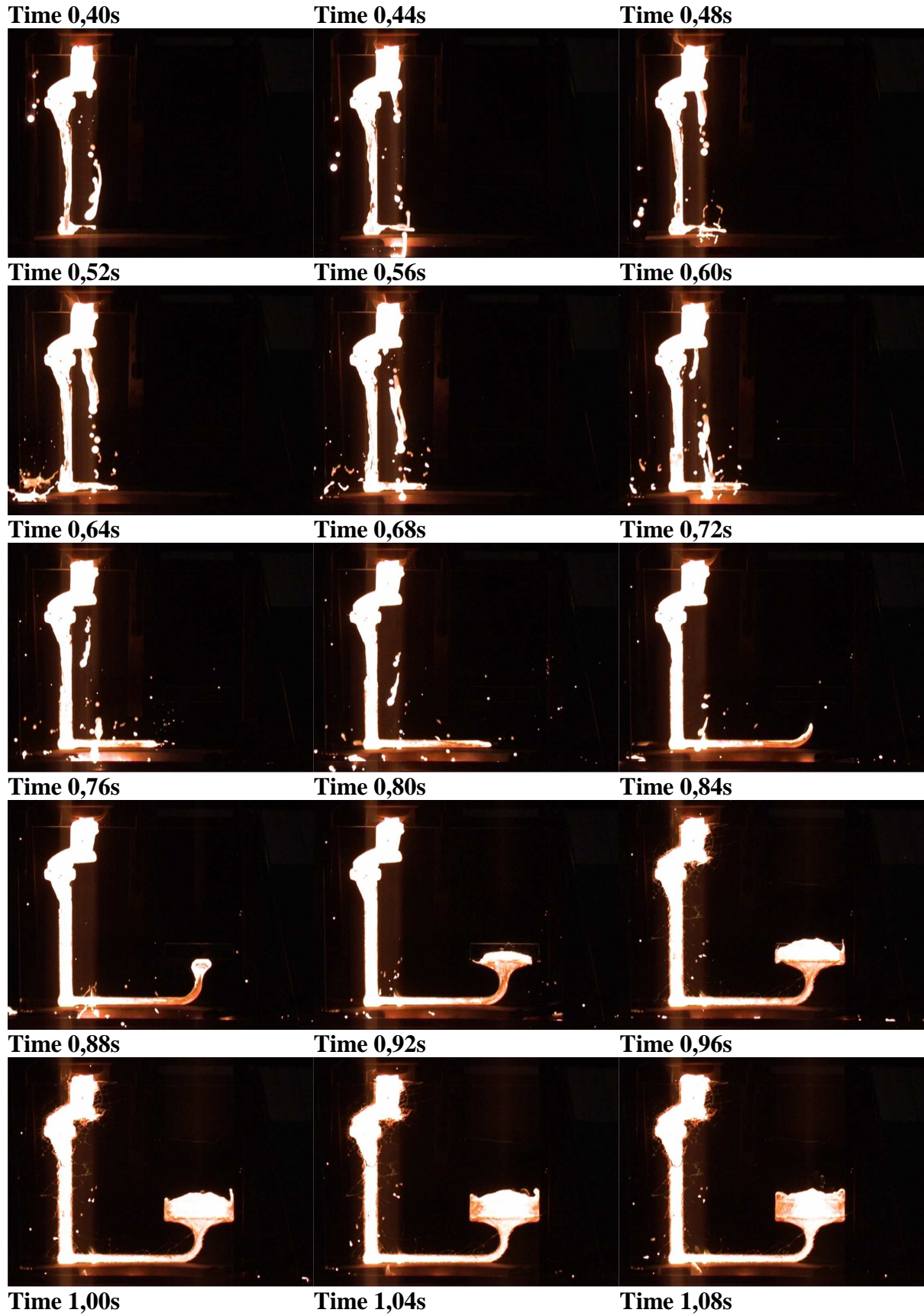
**8.6.1 Investigation of the mould filling**

The results from the glass plate experiments for the layout without filter was presented in the chapter ‘Runner width’. Parts of the results from the remaining layouts with filters are seen in the following. The full sets of frames from the experiments are seen in Appendix 4 – 14.4.1, 14.4.2 and 14.4.3. In all experiments here foam filters were used.

**Vertical 1 (a foam filter is used)**



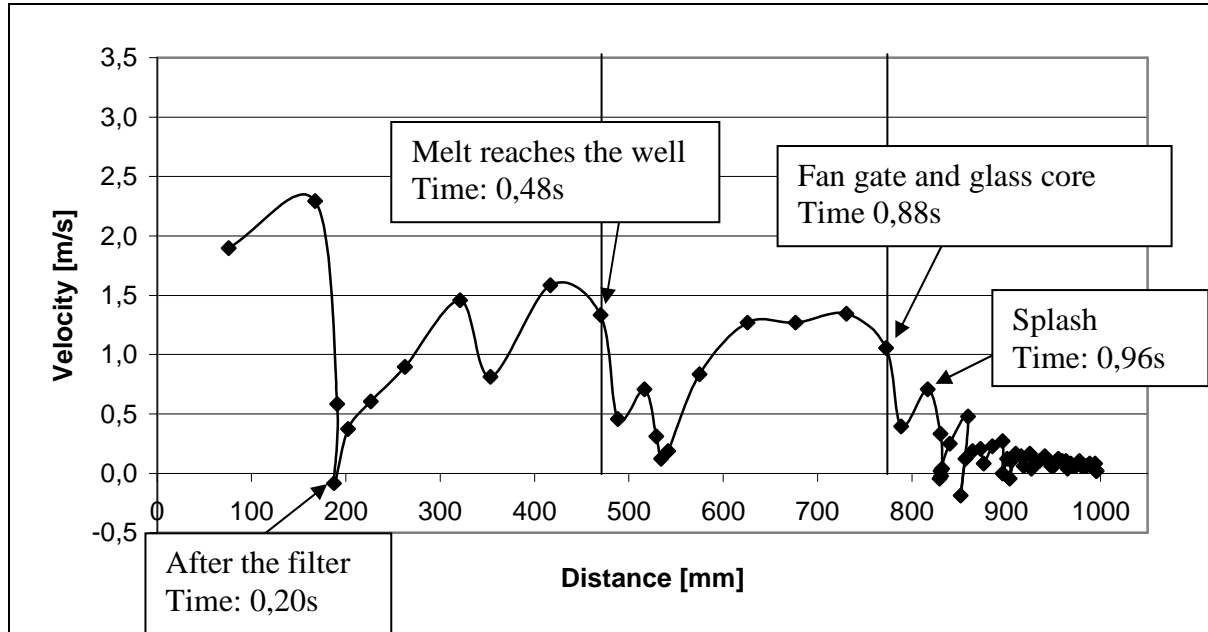




The pouring cup here is filled after 0,16s and the melt in a jet reaches the opposite side of the filter leaving a vena contracta just above the filter in the side of the pouring cup. This vena contracta is there till 0,40s. The very first melt to pass the filter at 0,20s seems to be circumventing the filter and does not flow through the filter. Whether this is the case or not is difficult to say from these experiments only but it is a possible scenario if the filter is smaller than specified. [Ref. 8-5] After the first melt has passed the filter a jet forms towards the right side of the down runner. This leaves a vena contracta in the right side underneath the filter. This part of the gating system is not filled till after 0,96s when the down runner is backfilled. By then the first melt has reached the casting with only a small amount of splashing compared to the layout with no filter. The reason for this calmer initial filling of the casting is partly the small glass plate mentioned earlier but mainly the backfilling of the down runner.

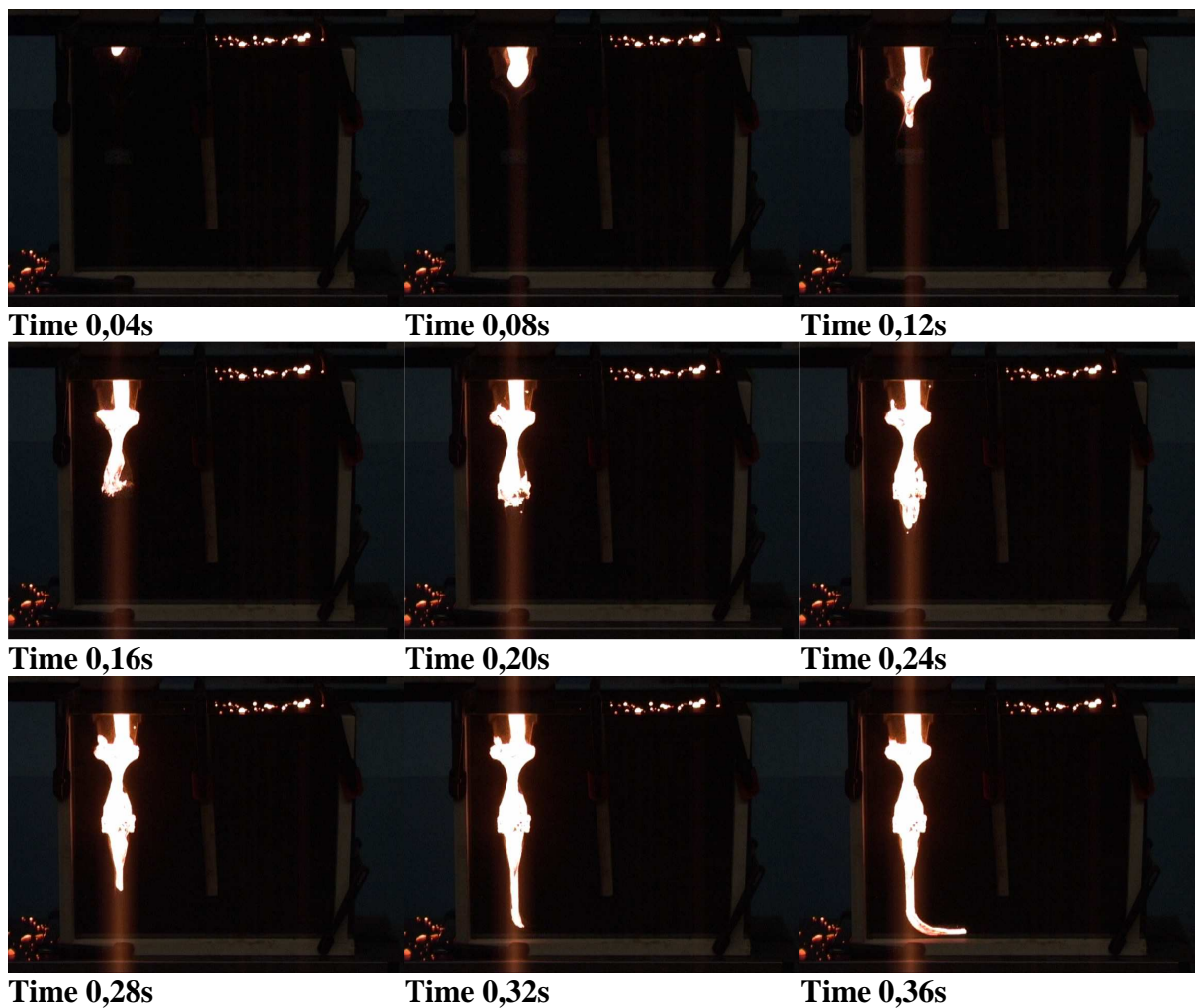
The fact that the down runner is not back filled till the time after the first melt has entered the casting decreases the momentum of this initial melt. One difference worth mentioning is the difference in the time for the melt to reach the fan gate. In the streamlined gating system with no filter the melt reaches the fan gate after only 0,36s whereas in the layout 'Vertical 1' with a foam filter the melt reaches the fan gate in 0,88s. It takes more than twice the time for the melt to reach the mould cavity with only a little less splashing inside the casting but with a much more turbulent flow and with gas entrapment in the runner system.

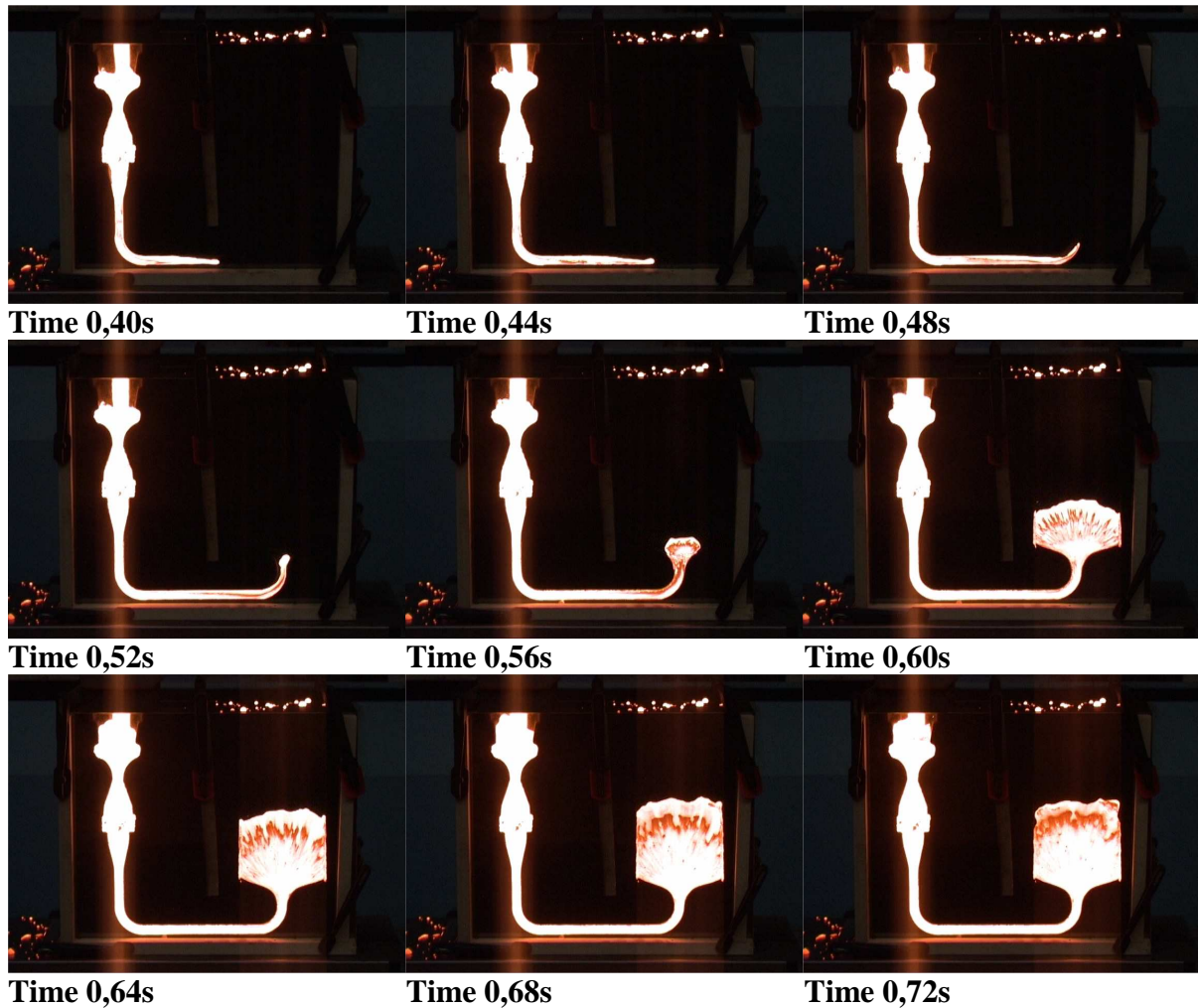
The result of the turbulent mould filling is also seen in Graph 8-1. The graph shows the velocity of the front of the molten metal through out the mould filling. It is seen that the maximum velocity is lower in the layout here than in the layout with no filter. The results also show that even though the velocities of the melt when reaching the fan gate is a lot higher in the layout with no filter the velocities for the melt when entering the casting is practically the same. The graphs show that the initial jet of the first melt entering the casting is very similar.



Graph 8-1 The graph show the measured velocities through out the mould filling

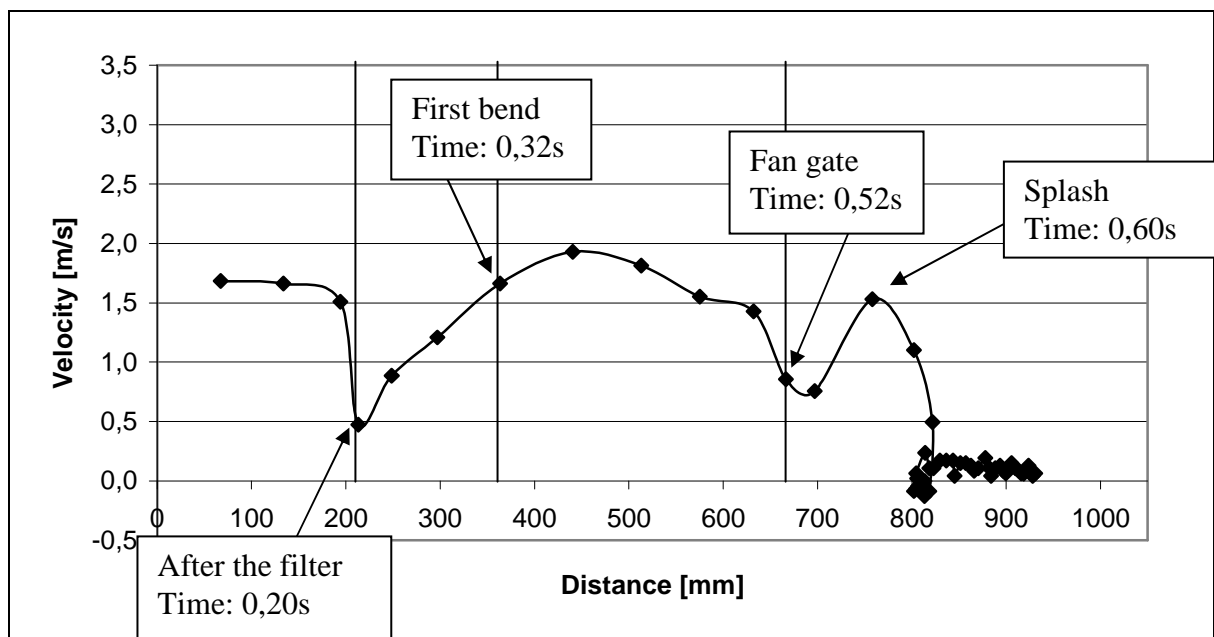
Vertical 2 (a foam filter is used)





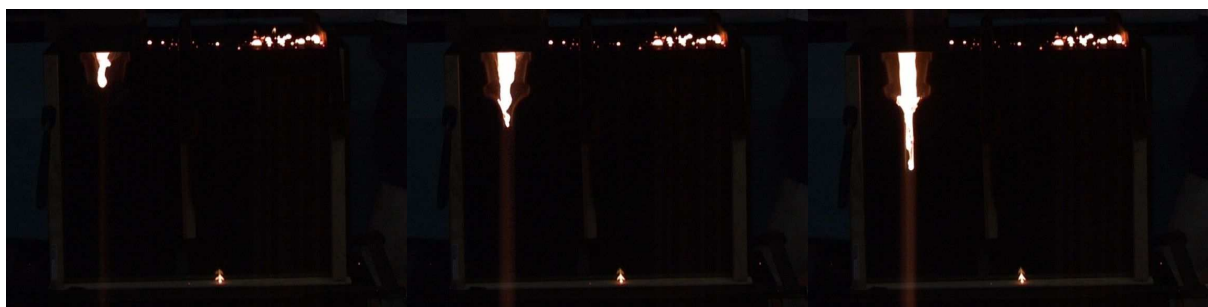
The layout here is very similar to the layout with no filter. The only difference is the expansion of the down runner to make room for the filter print. It is seen that the first melt to reach the front of the filter passes through easily and the front of the metal continues. The down runner backfills because of the increased volume around the filter and filter print. The down runner is full after 0,60s. At the same time the melt reaches the casting. The back filling of the down runner creates a pressure shock in the melt and because this shockwave is created at the same time the initial melt reaches the casting, it means a large initial jet of melt in the casting occurs. Due to the shock wave the jet is larger than seen in the results from the layout 'Vertical 1'. The time it takes for the melt to reach the fan gate in this layout is 0,52s which is only 0,16s more than seen in the layout with no filter. The explanation to this very small time difference is found in the increased poured weight of the gating system. It takes longer time to fill

the bigger volume of the gating system. The remaining filling of the mould resembles the layout with no filter. Graph 8-2 shows the velocity profile of the layout 'Vertical 2'. As seen for the layout 'Vertical 1' the velocity decreases at the filter. This means a lower maximum velocity. But even with a much lower maximum velocity the jet of the initial melt is a lot more severe. Having the same fan gate in either layouts the reason for this difference is the much more turbulent filling of the remaining part of the gating system.



Graph 8-2 The graph shows the measured velocities through out the mould filling

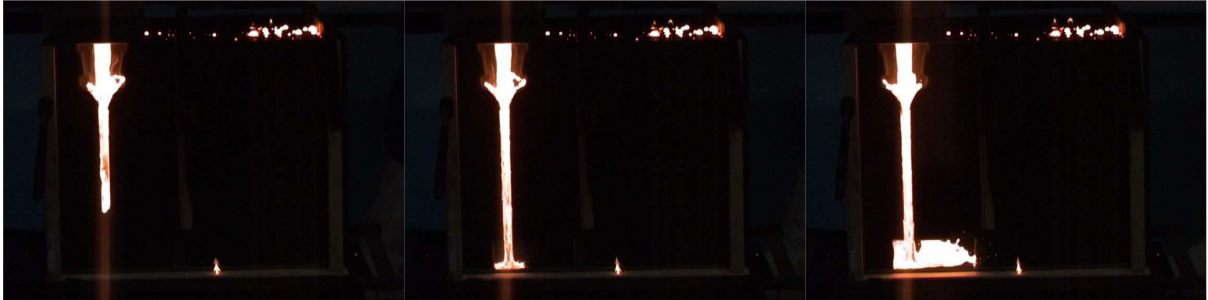
Horizontal (a foam filter is used)



Time 0,04s

Time 0,08s

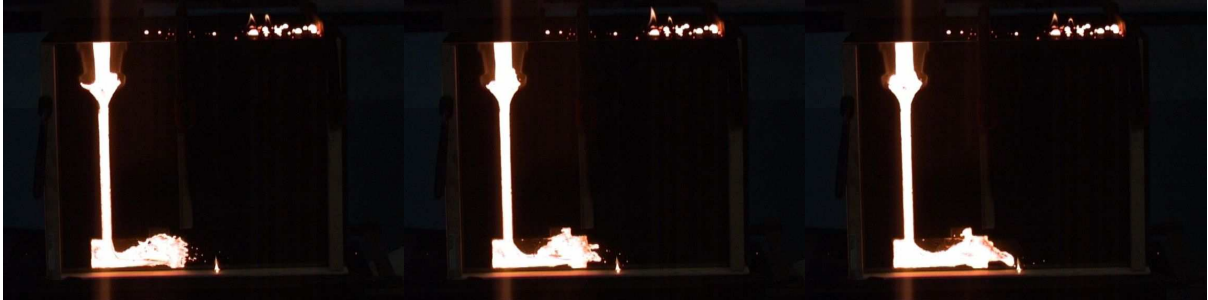
Time 0,12s



Time 0,16s

Time 0,20s

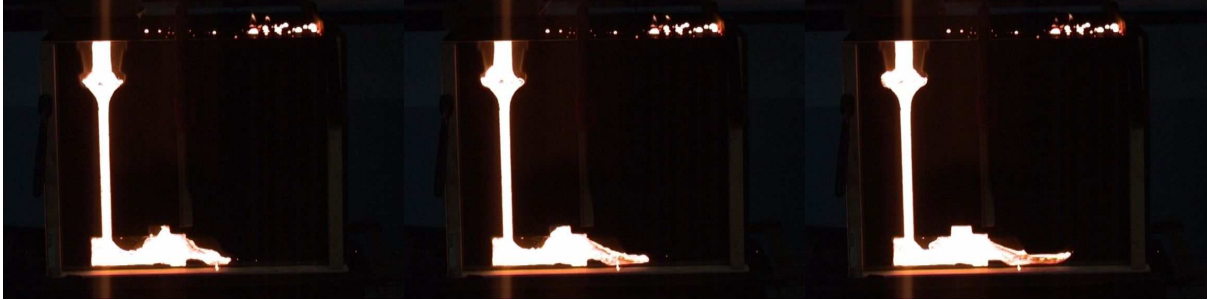
Time 0,24s



Time 0,28s

Time 0,32s

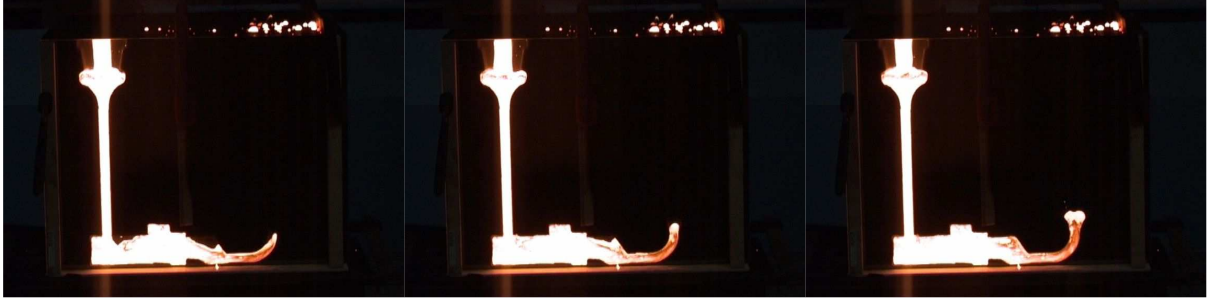
Time 0,36s



Time 0,40s

Time 0,44s

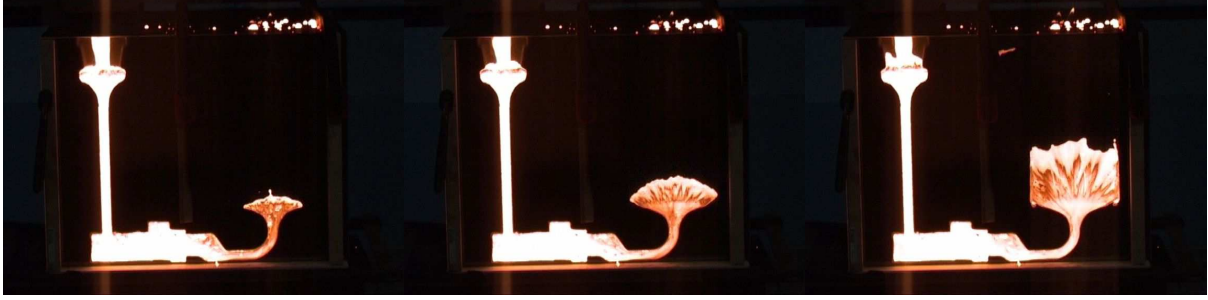
Time 0,48s



Time 0,52s

Time 0,56s

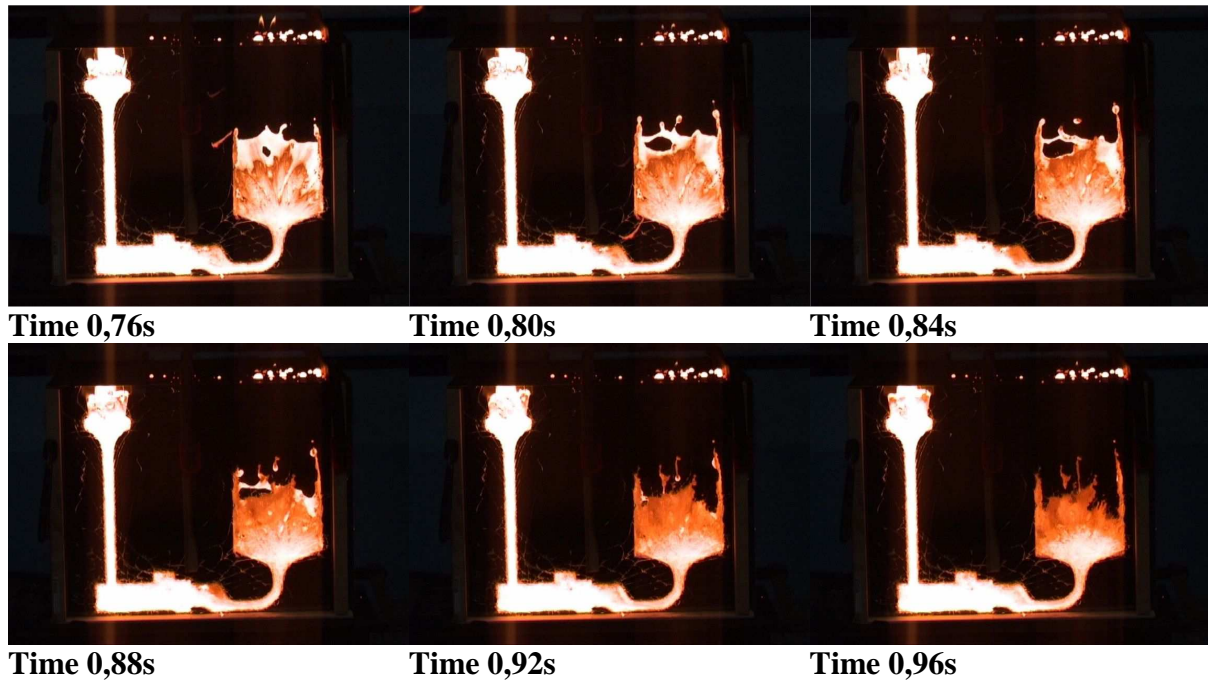
Time 0,60s



Time 0,64s

Time 0,68s

Time 0,72s



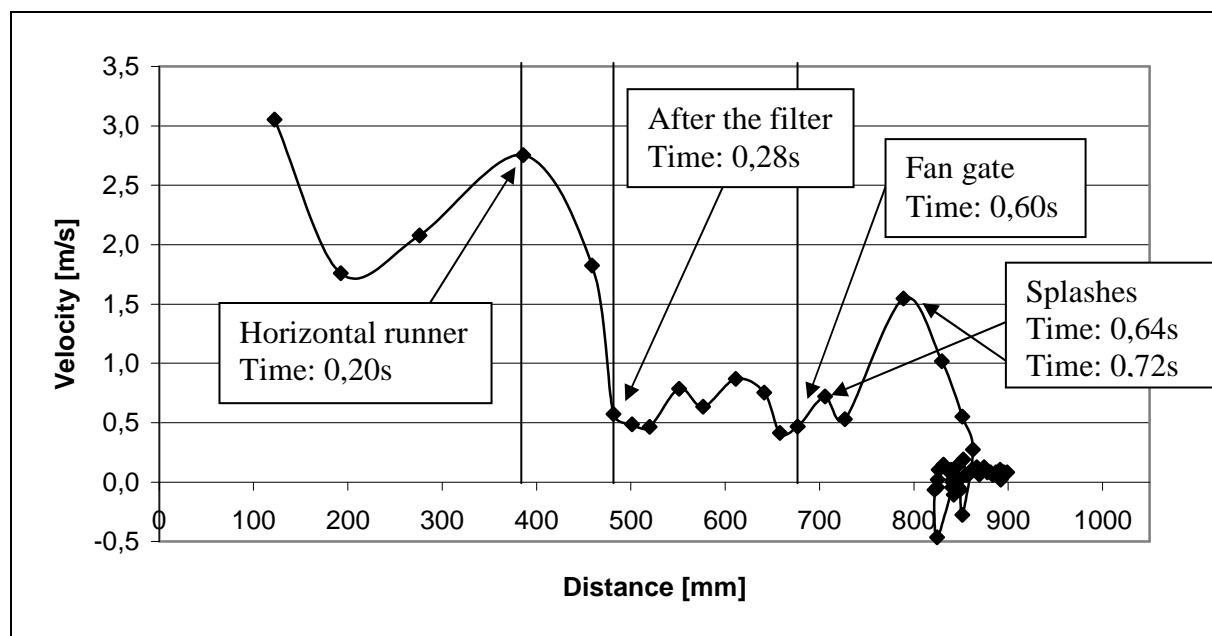
The first part of the gating system, before the runner, is a replica of gating systems often seen in horizontal moulding. It could be argued that the decrease in cross sectional area in the transition from the filter print and to the bend under the casting accelerates the melt. The response to this is that the down runner is an exact replica of the down runner used in the layout with no filter. This means that the flow rate is the same. The bend under the casting and the fan gate is the same as in the other experiments and should give the best possible foundation for the comparison of flow patterns.

When asking manufacturers of filters for the optimal filter position the response is as low as possible. [Ref. 8-6] This means that this layout, Vertical 2, should be preferable to the two layouts previously looked at. This is not the case though. When comparing how the metal enters the mould cavity the layout here causes the most violent and turbulent flow pattern. In the previous experiments the melt enters the casting cavity in a thin jet across the entire fan gate. In a few cases one or two small droplets of melt are seen. In the experiments here the melt enters the cavity more violently and a lot more than a few small droplets are observed. Part of the reason for this highly turbulent flow pattern is that the vena contracta that is found just after the base of the down runner

disappears completely after 0,72s possibly creating a pressure wave. But then the reason for placing the filter in the horizontal runner is among other parameters to minimize this exact problem [Ref. 8-6] [Ref. 8-7].

The time for the melt to reach the fan gate is 0,60s. These 0,24s prolonged filling time relative to the layout with no filter corresponds well with the additional volume of the gating system.

As just mentioned the filling of the vena contracta right after the down runner creates a pressure wave in the melt. This pressure wave is also seen in the velocities of the front of the melt during filling. Graph 8-3 shows how the melt reaches the fan gate at a very low velocity and then actually two jets are seen. First a very small jet at a time of 0,64s in the filling is seen. Then the velocity drops slightly before the second jet. The first small jet is expected as it was seen in all the earlier experiments. The second much larger jet is due to the mentioned pressure wave.



**Graph 8-3** The graph shows the measured velocities through out the mould filling

The reason why two pressure waves are seen here and not in the remaining layouts in which vena contracta was also observed is a matter of at what time the pressure wave



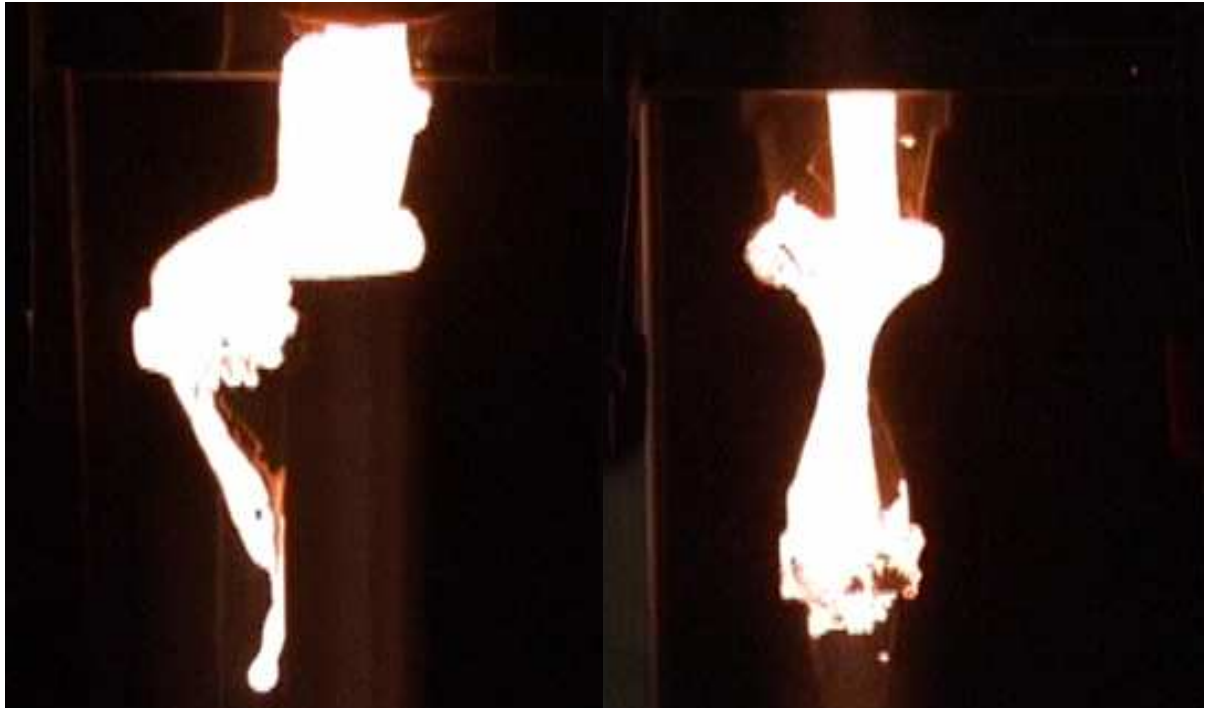
reaches the front of the flowing metal. In the experiment with the layout ‘Horizontal’ this happens at a time when the effect of the first jet is declining. This means that the second jet is not covered by the first as was the case presented for ‘Vertical 2’. To do a closer study of effects like these it is necessary to film with more frames per second as has been used in these experiments.

### 8.6.2 The first melt passing through the filters

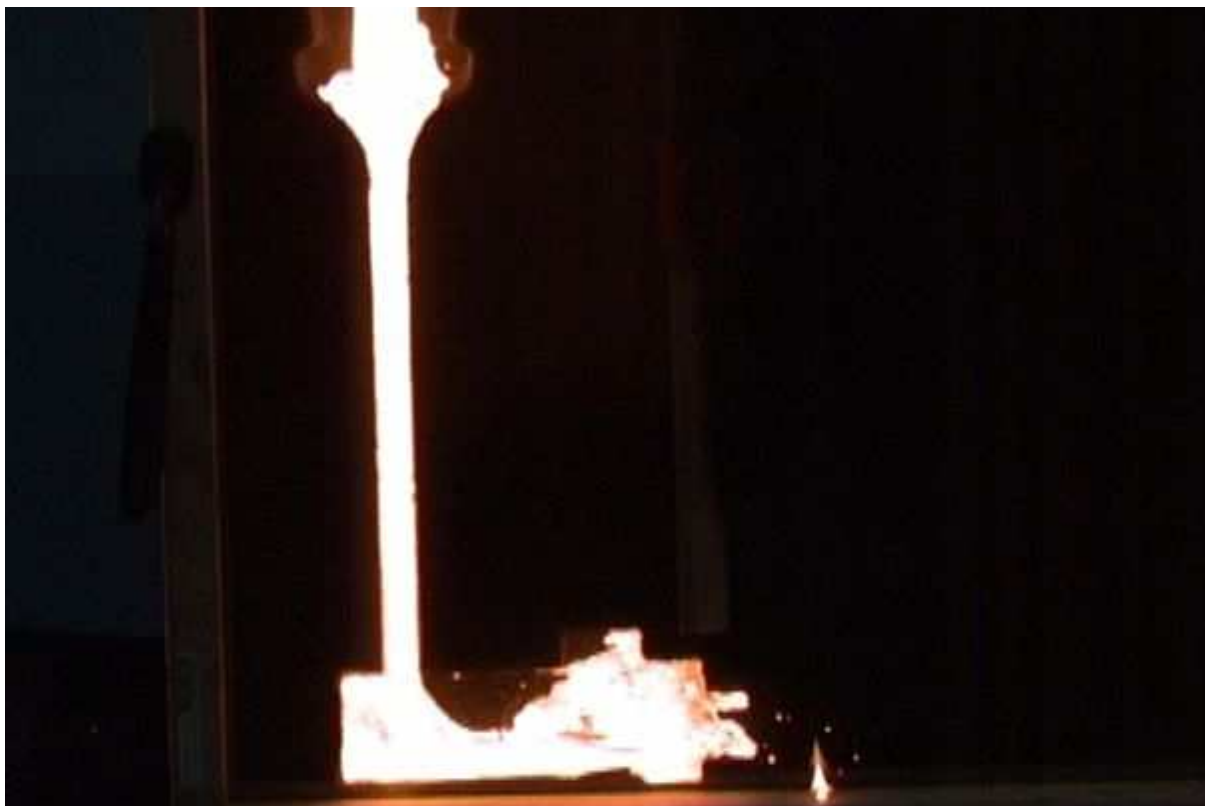
One of the purposes using filters is to reduce velocity but also to achieve a less turbulent flow pattern after the filter. To get a clearer picture and see if this is actually what happens when using a filter a closer investigation is necessary. Frames from each of the layouts here and a single frame from the glass plate experiments in the chapter ‘Casting of a valve housing’ with a filter showing the melt passing through the filters are shown in Figure 8-9, Figure 8-10 and Figure 8-11. The frames in Figure 8-9 are with pressed filters while the frames in Figure 8-10 and Figure 8-11 are with foam filters. The frame to the left in Figure 8-9 is a frame from when most of the gating system is already filled.



**Figure 8-9** The two frames show how the melt is divided into smaller streams when using pressed filters.



**Figure 8-10** Frames from the glass plate experiments showing the initial melt passing through the foam filters. The frames show that the melt does not exit the filter in a coherent stream.



**Figure 8-11** Frame from the glass plate experiments showing the initial melt passing through the foam filter. The frame shows that the melt does not exit the filter in a coherent stream.

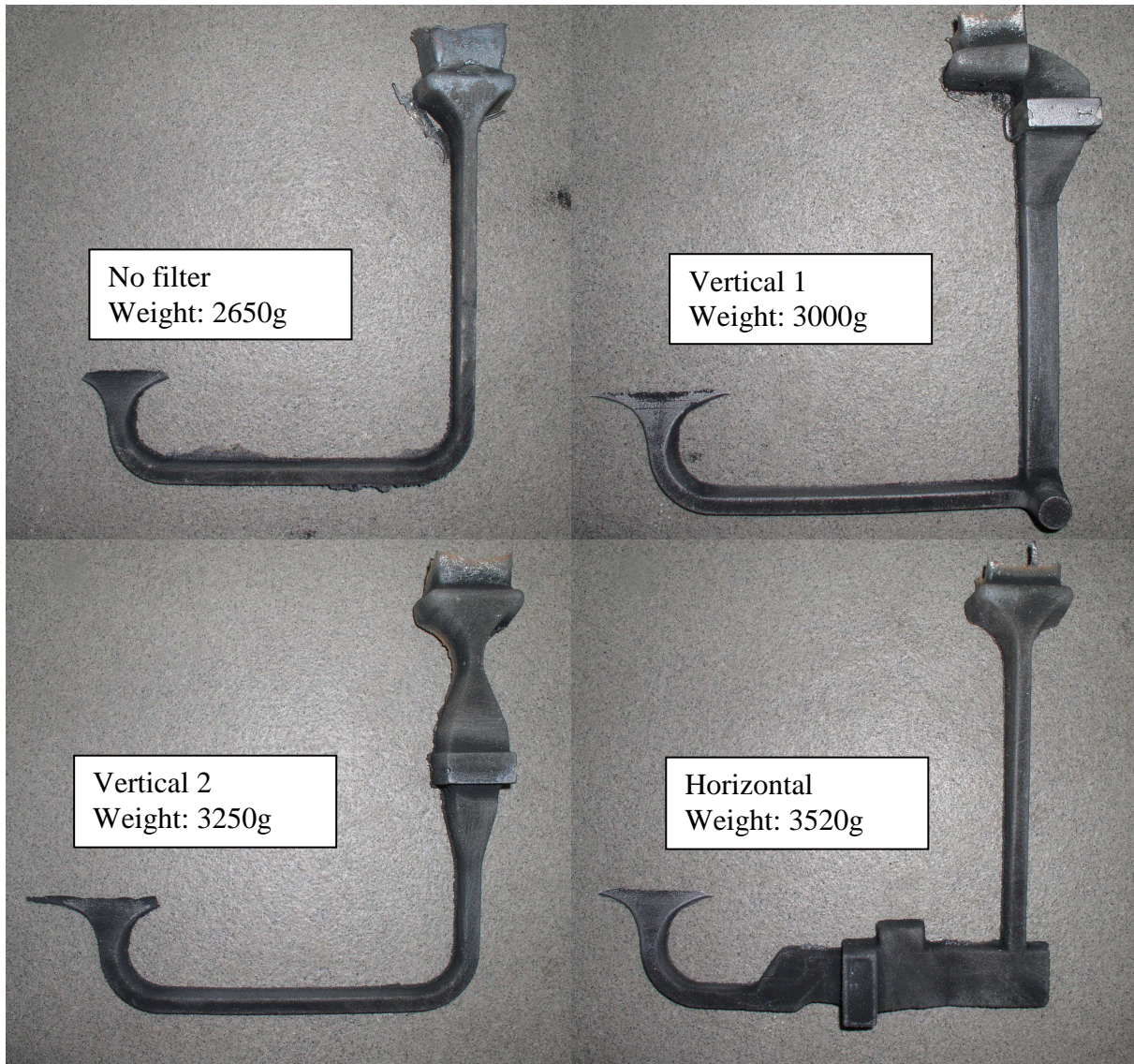
When looking at the two frames in Figure 8-10 it is seen that the first melt to exit the foam filters is highly turbulent. The melt leaving the filter is divided into a lot of very small streams of melt leaving in slightly different directions. In many ways this flow pattern resembles the flow patterns seen using pressed filters in Figure 8-9. These flow patterns promote oxidation of the melt forming oxides that the filter was meant to prevent. In addition to this, the small streams of metal promote gas entrapment leading to an increase in gas porosities in the casting. When looking at the frame in Figure 8-11 it is found that even though it is normally recommended to place the filter in the horizontal runner and not in the down runner the flow pattern is still the same. In Figure 8-11 it is seen very clearly that even though the majority of the melt is stopped by the filter still some melt continues directly through forming small jets on the exit surface. It is often believed that the filter ensures that the runner system prior to the filter is filled before the metal starts to go further. [Ref. 8-8] The results presented here prove that this is wrong.

Often water-analogy studies are used to explain and demonstrate the benefits in controlling the flow of the molten metal making the mould filling less turbulent. [Ref. 8-9] The experimental results presented here show very clearly that these experiments do not represent how the flow of metal is through the filter when used in the mould. The reason is the difference in density of water and molten metal. The momentum of the molten metal is much higher having a density of around seven times that of water.

### **8.7 Recommendations regarding the use of filters**

The experiments have shown that using pressed filters or foam filters in the way they are normally set in the mould the result in an increased turbulence during mould filling. It is often claimed that filters decreases the turbulence and promotes a calmer filling [Ref. 8-6]. In all cases it is found that the filter splits the metal into smaller streams or jets generating oxides and gas entrapment in the melt. In addition the filter prints generates areas with vena contracta on either side of the filter again resulting in gas entrapment and pressure shockwaves. These shockwaves generated during filling

have been proven to actually give much more turbulence and gas entrapment than is the case in the streamlined gating system with no filter.



**Figure 8-12** The pictures show the different layout as cast but without the plate shaped casting. Along with the pictures the weight is found. The filter print that has been modified the least and therefore gives the best comparison is ‘Vertical 2’.

Having compared a streamlined layout with no filter and three layouts with different filter prints the general recommendation must be to avoid the use of filters if possible. The use of filters should have the purpose of removing unwanted particles in the melt only rather than as a sort of flow control. A further recommendation therefore is to have a clean melt before even pouring. Instead of trying to avoid problems with

inclusions at the time just before the melt enters the actual mould cavity emphasis should be put on removing the unwanted particles much earlier. Batch filtration could be one way of removing these unwanted particles. [Ref. 8-5]

A further benefit of not having the filter in the mould is a reduction in the poured weight improving yield. Since the filter prints have been modified for these experiments the actual saving in poured weight is not easy to compare. A clear indication can be given though. All of the modifications have led to a reduction in the volume of the filter prints. In Figure 8-12 the four gating systems are seen and their weight is found as well. The layout that is most similar with the layout with no filter is the layout called 'Vertical 2'. This layout is also the one in which the filter print has been modified the least. Therefore to compare 'Vertical 2' and the layout with no filter gives the best indication of saving in pouring weight. It can be seen that a saving of 600g in poured weight is achieved in this case for each mould.

The filter print in the layout 'Vertical 2' is designed for use in vertically parted moulds in for example a DISAMATIC moulding machine. A machine like this produces around 350 moulds an hour when filters and cores are needed and in every mould 600g of metal is saved by not having the filter. This adds up to a total saving of 210kg of molten iron per hour and 1680kg each eight hour workday. This example shows that huge improvements in yield can be achieved in combination with a less turbulent flow pattern and less gas entrapment during mould filling.

## References

**[Ref. 8-1] Foseco – Production experiences with improved filtration of ductile iron castings**

**[Ref. 8-2] Andrews I.A., Matthews A.L. – Molten Metal Filtration An Engineered Balance. Hamilton Technical Ceramics.**

**[Ref. 8-3] Andrews I, Dumaillet J.-M., Diószegi A – Direct flow simulations in pressed foundry filters. Issued by the Australian Foundry Institute 34<sup>th</sup> National Convention, 2003**

**[Ref. 8-4] Skaland T, Grong Ø. and Grong T. – A Model for the Graphite Formation in Ductile Cast Iron: Part I. Inoculation Mechanisms. Metallurgical Transactions A, Volume 24A, October 1993**

**[Ref. 8-5] Matthews A.L., Ceramic Filters for the Cast Metal Industri, Key Engineering Materials Vols. 122-124 pp. 293-304, 1996**

**[Ref. 8-6] Foseco – Sedex The ceramic foam foundry filter, 2007**

**[Ref. 8-7] Foseco – Sivex FC Machineable Foam filters, 2007**

**[Ref. 8-8] Gebelin, J.-C. and Jolly. M – Numerical modelling of metal flow through filters, Modelling of Casting, Welding and Advanced Solidification Processes X, 2003**

**[Ref. 8-9] Davies R. – Clean Metal, The ‘Holy Grail’ for all foundries, Foundry Trade Journal vol. 180 pages 283-285, 2006**



## 9 Experiments using X-Ray

Many experiments have been conducted as mentioned earlier using glass plate fronted moulds. However it has not yet been investigated how much the glass plate affects the flow pattern during mould filling. One concern about the glass plate is the cooling rate of the melt against the glass plate compared with the cooling rate of the melt against the sand mould. Another concern is whether the flow is affected due to the difference in surface roughness between the sand mould and the glass plates. To investigate this, a series of experiments were conducted at the Metallurgy and Materials department at the University of Birmingham. The facilities are described in the previous chapter 'Experimental facilities'.

### 9.1 The layout and the pattern plates

A layout was designed for the casting of two plates each with a thickness of 10 mm. To be sure that there would be room enough in the x-ray chamber there were certain restrictions to the size of the mould. The layout can be seen in Figure 9-1.

The right upper corner is cut off to make sure that the CNC guided pouring ladle can get close enough to pour without risking that the ladle collides with the mould.

It is possible to have a 4mm thick core located 4mm above the fan gate. The reason is to make it possible to investigate how the flow is affected if the melt when entering the mould cavity is guided directly into a core. An arrangement like this is often recommended in high pressure die casting. [Ref. 9-1]



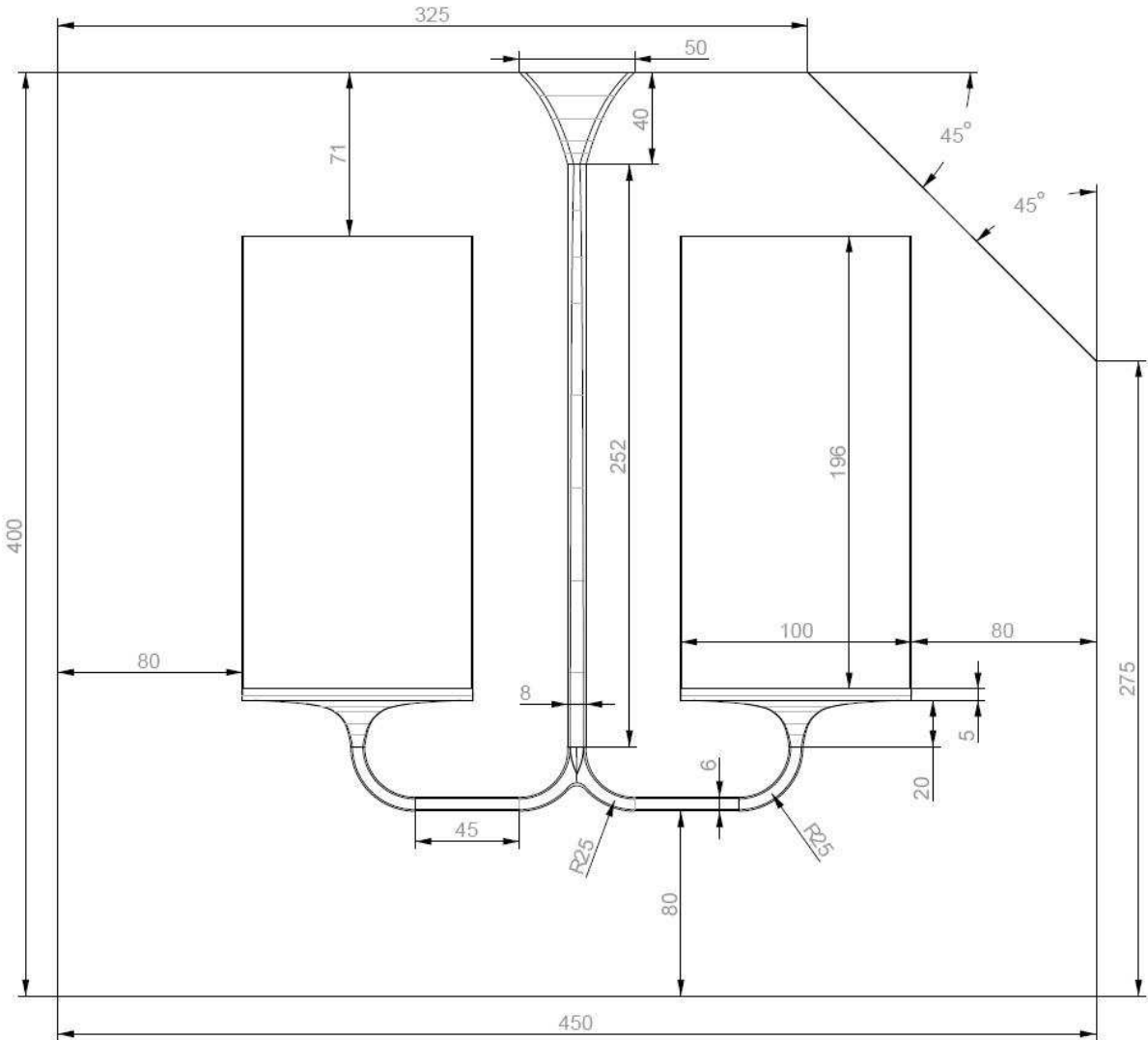
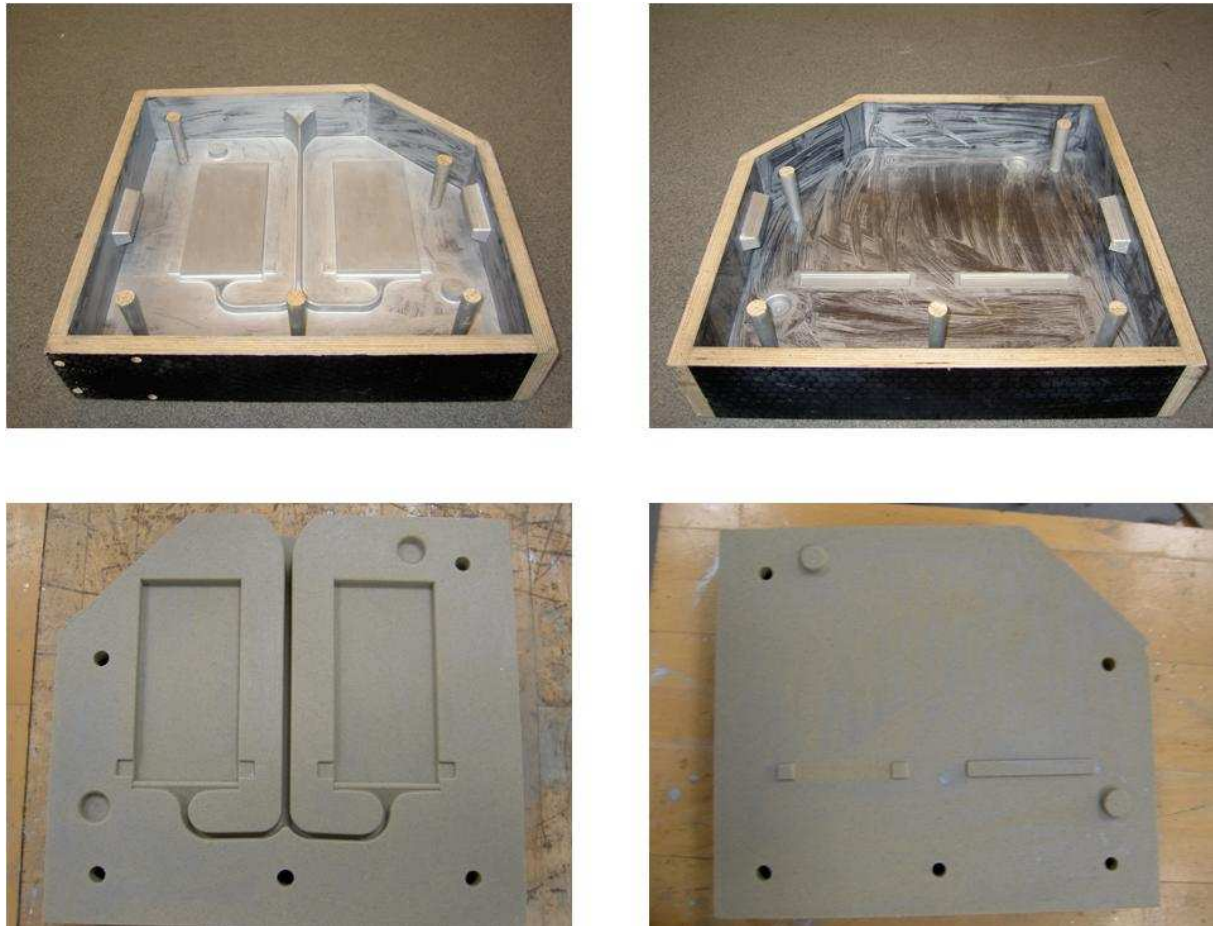


Figure 9-1 The layout for the x-ray experiments. All measurements are in millimetres.

The pattern plates and a set of moulds can be seen in Figure 9-2. The fan gate in this layout is only one millimetre thick just before the castings.



**Figure 9-2** Top left: Pattern plate with the castings. Top right: Pattern plate with the ‘cores’. Bottom left: Sand mould with the castings. Bottom right: Sand mould with the core to the left removed and the core to the right intact.

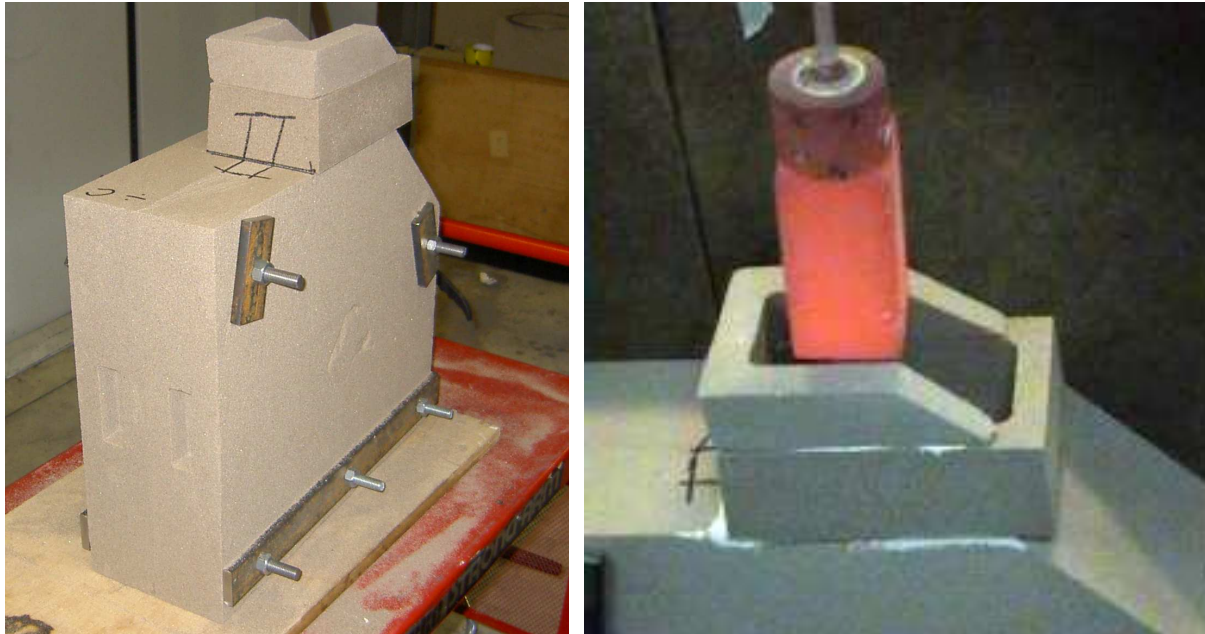
## 9.2 Experimental procedure

### 9.2.1 The mould

After the mould is put together a pouring basin is glued on top of the mould. Figure 9-3 shows the fully assembled mould ready to be placed in the X-Ray chamber. As can be seen the mould is held together using five bolts and three pieces of steel on each side.

When pouring it is very important from the very beginning to pour fast enough. If pouring is not fast enough the runner system will not be filled properly. Every cross section in the runner system is calculated with the assumption that the rest of the runner system is full. Therefore if this is not the case it is not possible to see the

correct flow pattern. The preliminary experiment showed that using only the pouring device it did not give a sufficiently fast pour in the very start. In this way the experiments showed the necessity of having a stopper.



**Figure 9-3 To the left: The fully assembled mould ready to be placed in the X-Ray chamber. To the right: Preheated stopper being placed in the pouring basin**

A stopper was therefore made from graphite. The stopper is seen in Figure 9-3. The stopper had a square cross section with a flat base. In this way the stopper was easily placed correctly every time and it covered the entire top of the funnel in the sand mould. A piece of iron (the cylindrical part seen in Figure 9-3) was placed on top of the graphite stopper. This was done to add weight to prevent the stopper from floating when metal is poured into the basin.

The stopper was preheated to a temperature of 800°C before being placed in the pouring basin. The stopper cooled down to approximately 500°C before the pouring. The preheating of the stopper was done to minimize the heat loss of the melt when in contact with the stopper.

Via a chain the stopper was connected to a pneumatic arm which was activated by pressing a button in the control room. In this way the stopper could be pulled up after the first melt had been poured from the ladle into the basin.

### 9.2.2 Magnesium treatment

As described in the chapter 'Experimental facilities' the melting was done in the same crucible as was used for placing in the pouring device. This was done to minimize the heat loss that would be expected when melting a very limited amount of metal. The magnesium treatment was likewise done in the same crucible while the crucible was still placed in the furnace. In this way the magnesium treatment could be done at a temperature of around 1400°C and the melt could be shortly re-heated in order to obtain the desired pouring temperature. The actual magnesium treatment was done by placing the treatment alloy (5,5% MgSiFe) on top of the melt and then with a tool pressing the treatment alloy to the bottom of the melt.

### 9.2.3 Recording using X-Ray

The flow of metal is recorded for these experiments by 60 frames per second. To get a good recording and representation of the flow of molten iron through the fan gate and into the 10mm thick plate the x-ray was set to 225kV and 6mA.

## 9.3 Experimental results

To find all the correct parameters and settings for the casting of iron a test casting with gray iron was done as a preliminary experiment. This casting was done without a stopper and is numbered 'Gray iron 1'.

For the actual experiments with cast iron 8 moulds were cast in total. All 8 were cast using a stopper. Four were cast with gray iron and four were cast with ductile iron. Two of each alloy were cast with the cores intact and two of each alloy were cast with the cores removed. For the moulds where a magnesium treatment was performed, mould one and three were cast with the cores intact and mould two and four were cast

with the core removed. For the gray iron castings the core was left intact in mould two and five and the core was removed in mould three and four. The table below shows this more schematically.

Ductile iron 1 With cores	Ductile iron 2 No cores	Ductile iron 3 With cores	Ductile iron 4 No cores
Gray iron 2 With cores	Gray iron 3 No cores	Gray iron 4 No cores	Gray iron 5 With cores

**Table 9-1 The table shows the order in which the castings were done**

The results for three of the castings are presented in the following. These results consist of the frames from the films and a graph for each showing the velocity of the melt plotted against the distance the melt has moved. The frames are presented here in three columns so that the differences in flow patterns are more easily seen. The results are also found in Appendix 5 – 14.5.1, 14.5.2, and 14.5.3. All of the films from the experiments are also found on the DVD.

**Ductile iron 1**

**Ductile iron 3**

**Ductile iron 4**



**Time 0,016s**

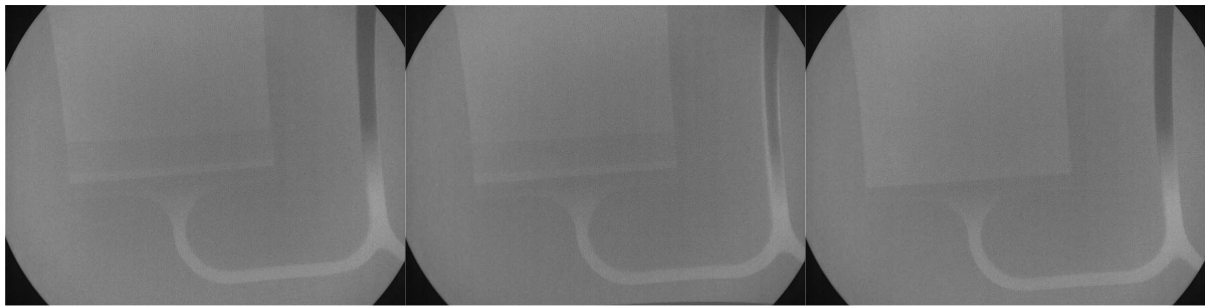


**Time 0,033s**

Ductile iron 1

Ductile iron 3

Ductile iron 4



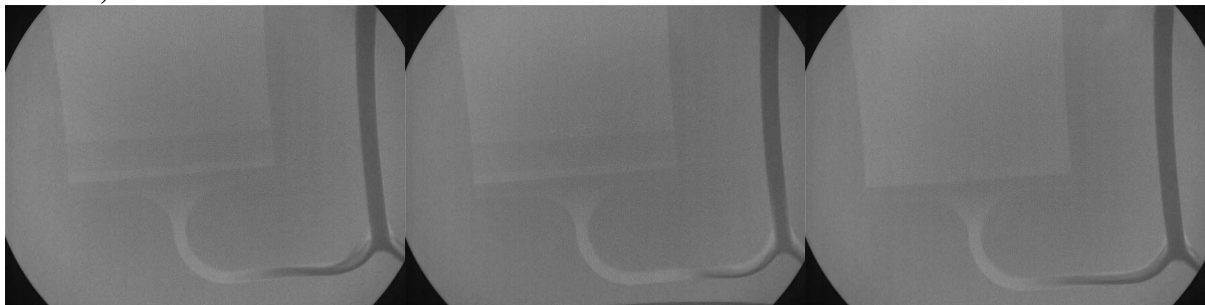
Time 0,050s



Time 0,067s



Time 0,083 s



Time 0,100s

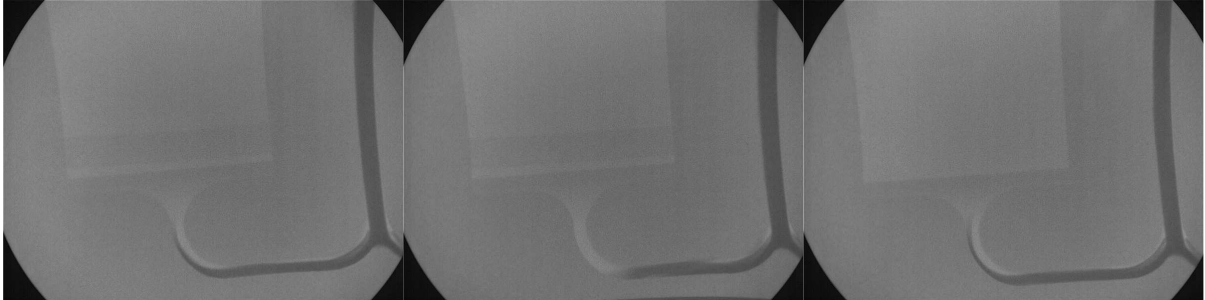


Time 0,117s

Ductile iron 1

Ductile iron 3

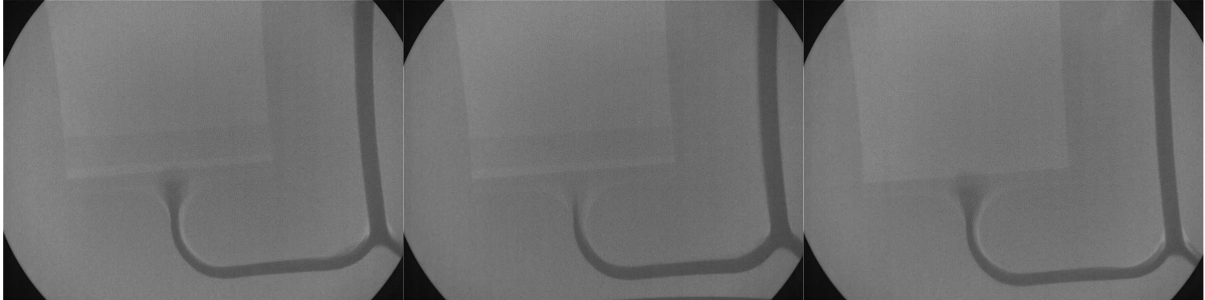
Ductile iron 4



Time 0,133s



Time 0,150s



Time 0,167s



Time 0,183s

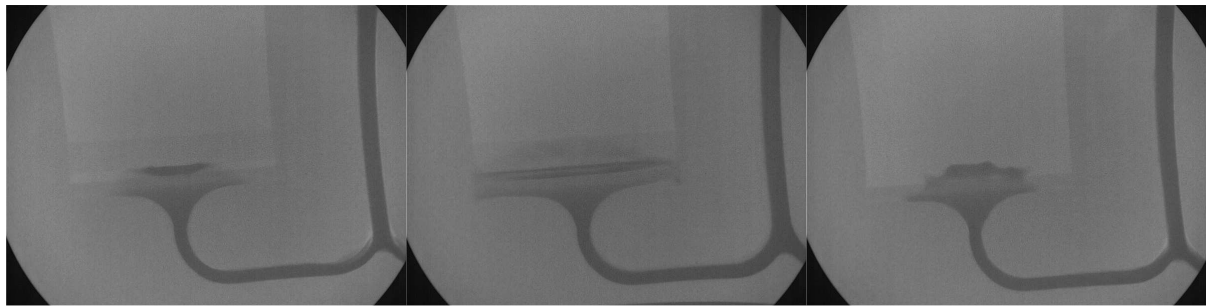


Time 0,200s

Ductile iron 1

Ductile iron 3

Ductile iron 4



Time 0,217s



Time 0,233s



Time 0,250s



Time 0,267s



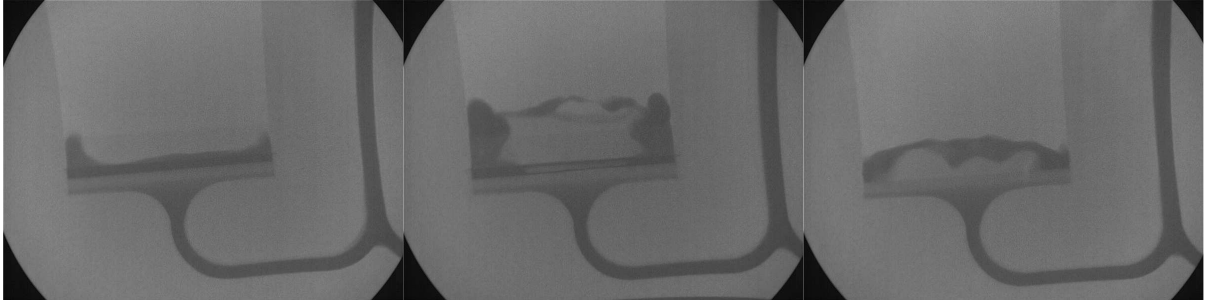
Time 0,283s



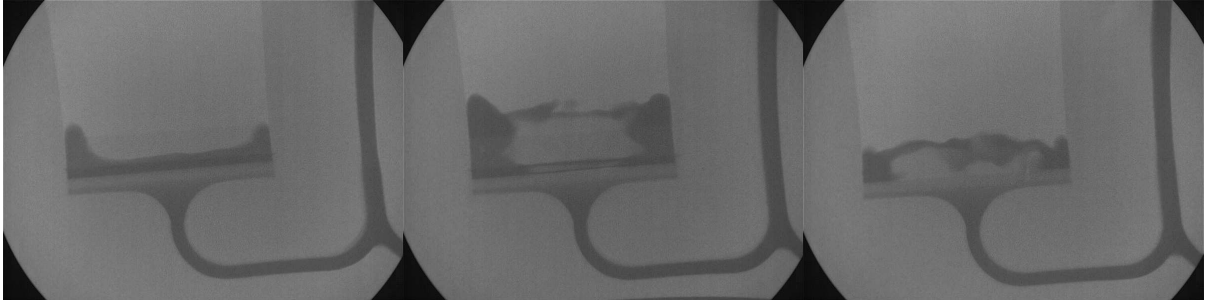
Ductile iron 1

Ductile iron 3

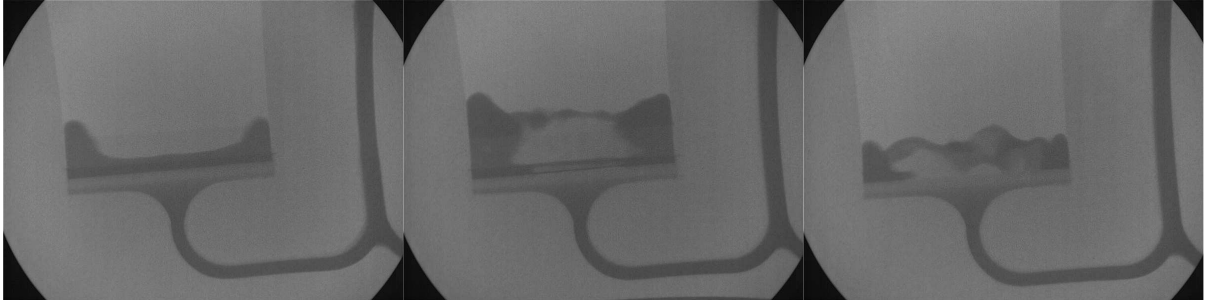
Ductile iron 4



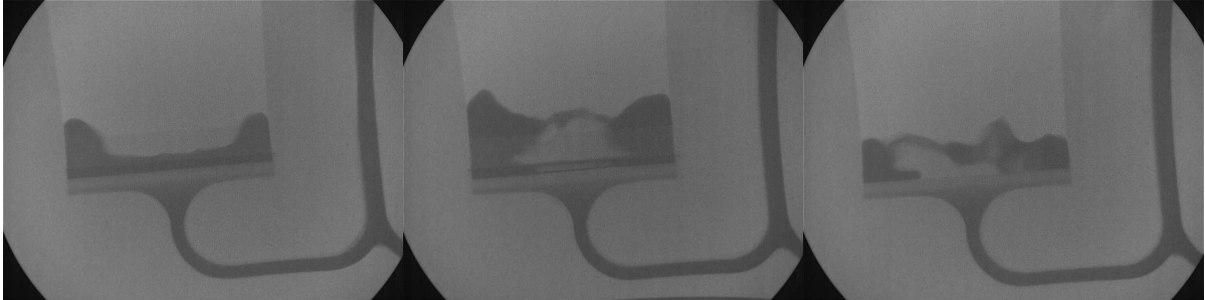
Time 0,300s



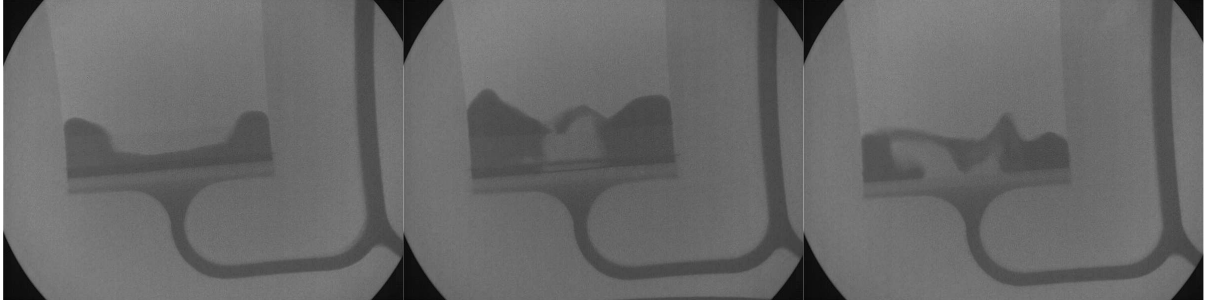
Time 0,317s



Time 0,333s



Time 0,350s

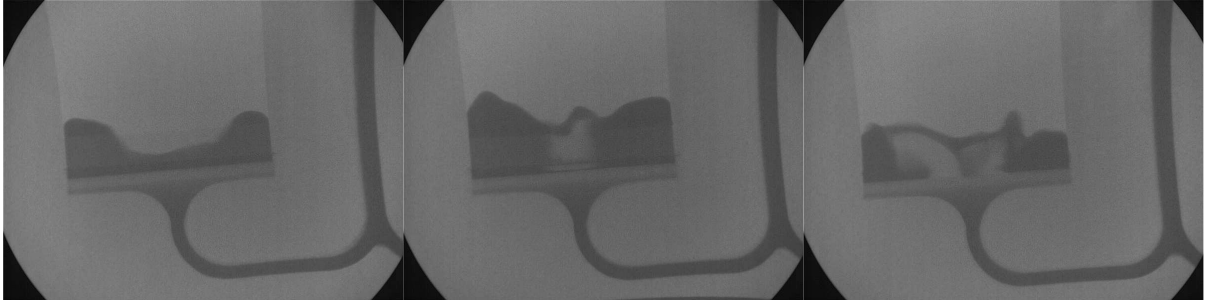


Time 0,367s

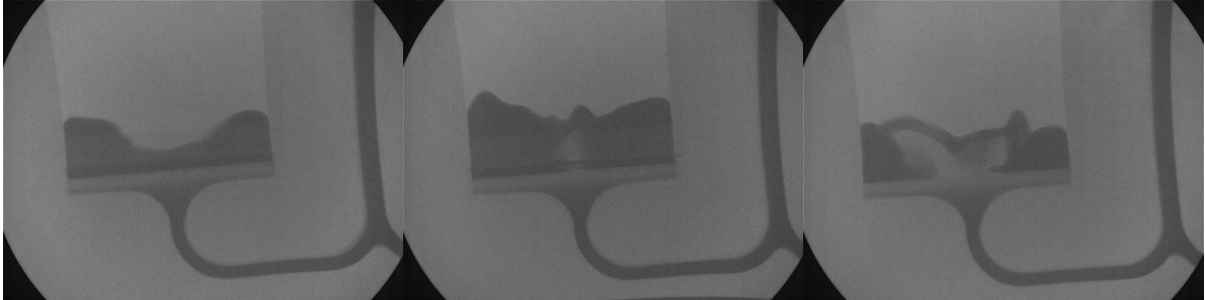
Ductile iron 1

Ductile iron 3

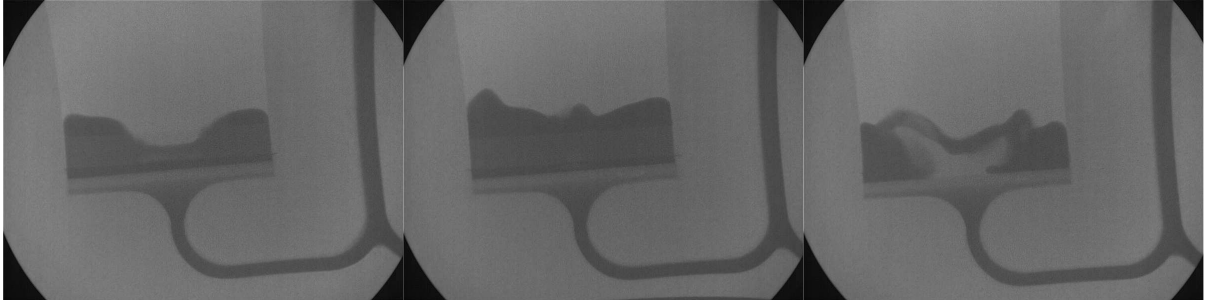
Ductile iron 4



Time 0,383s



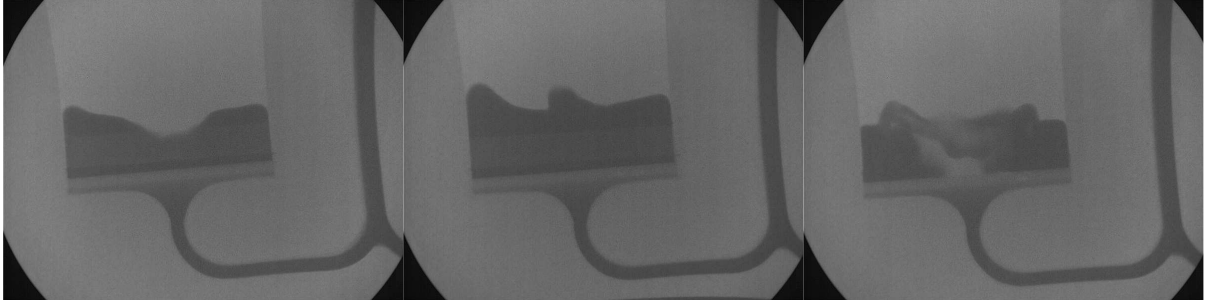
Time 0,400s



Time 0,417s



Time 0,433s

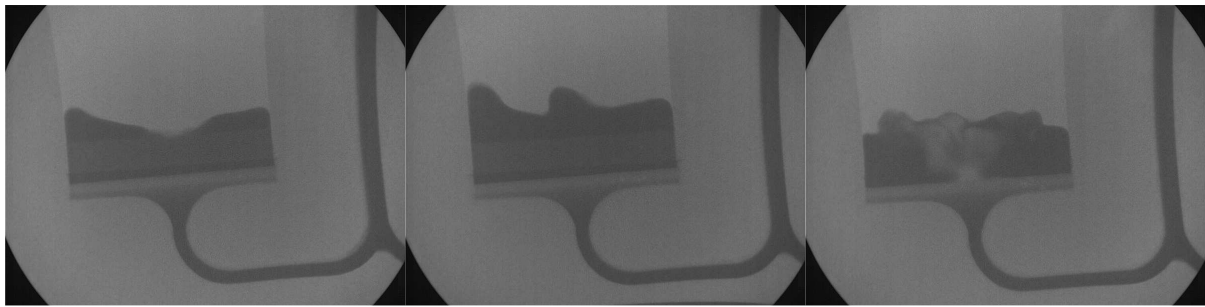


Time 0,450s

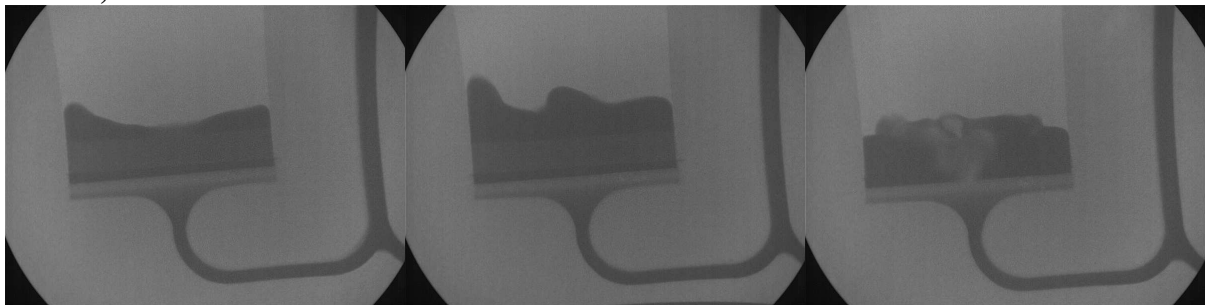
Ductile iron 1

Ductile iron 3

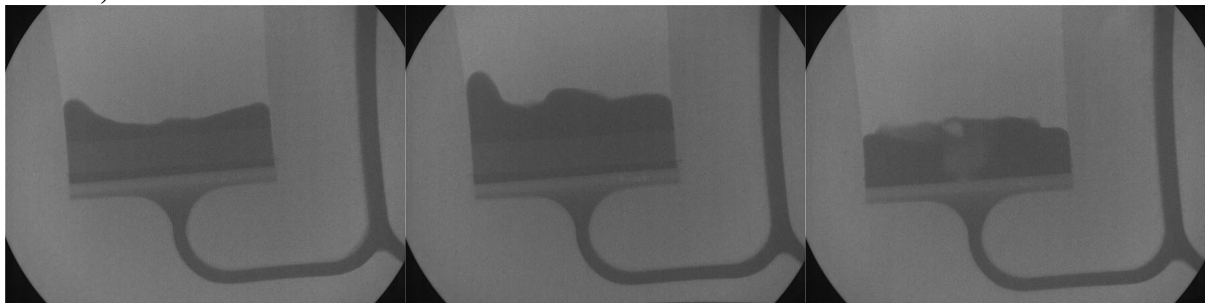
Ductile iron 4



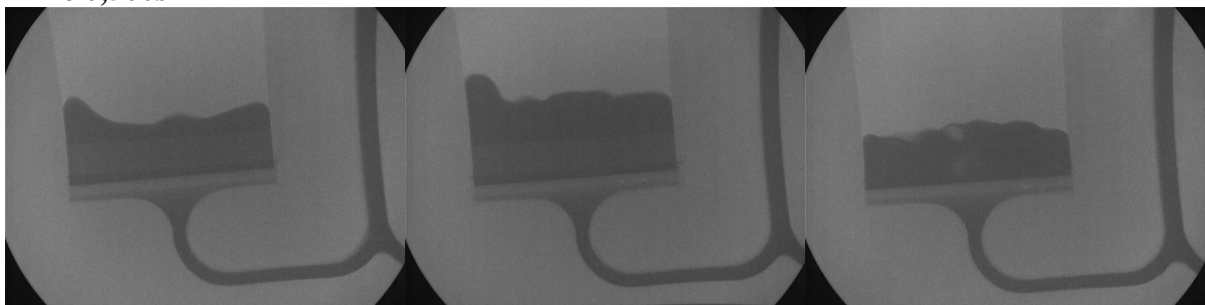
Time 0,467s



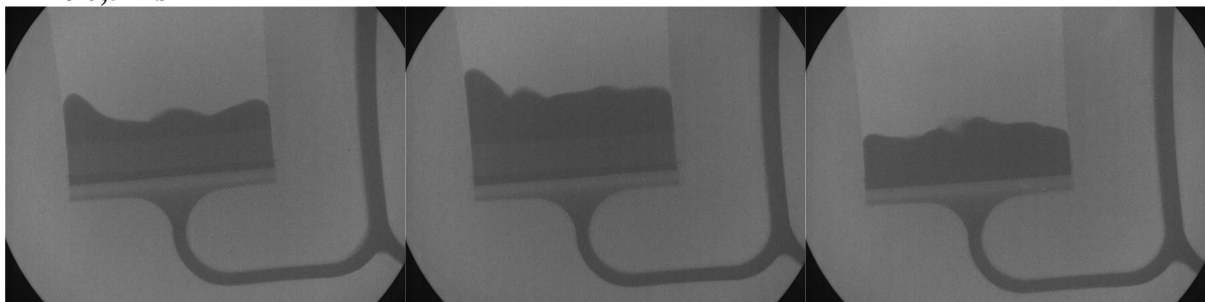
Time 0,483s



Time 0,500s



Time 0,517s

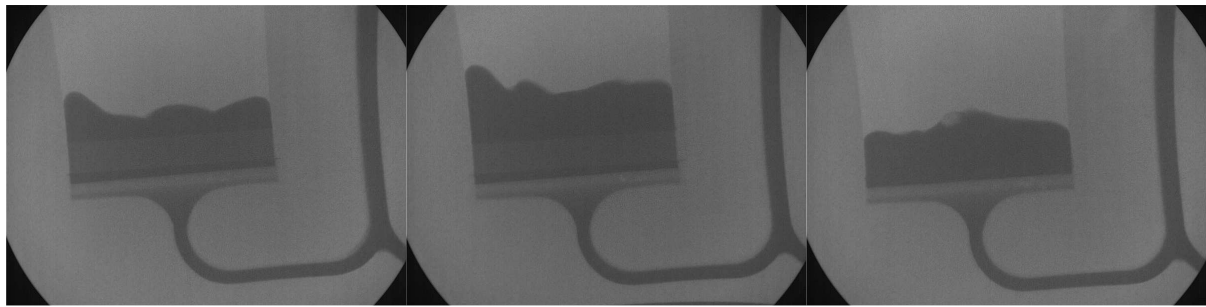


Time 0,533s

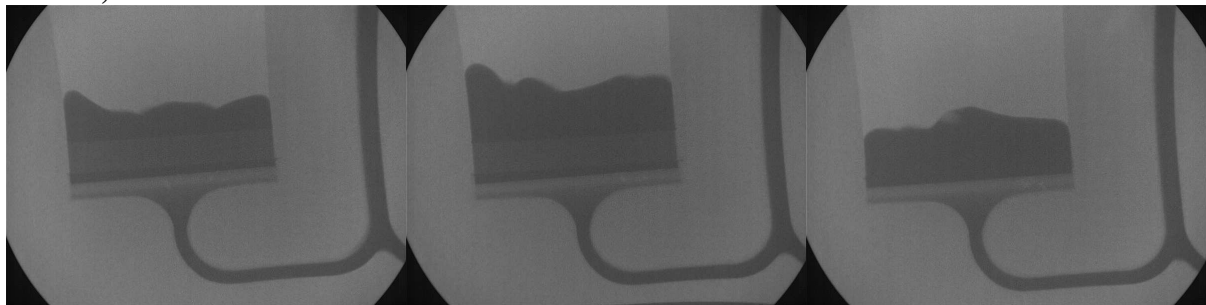
Ductile iron 1

Ductile iron 3

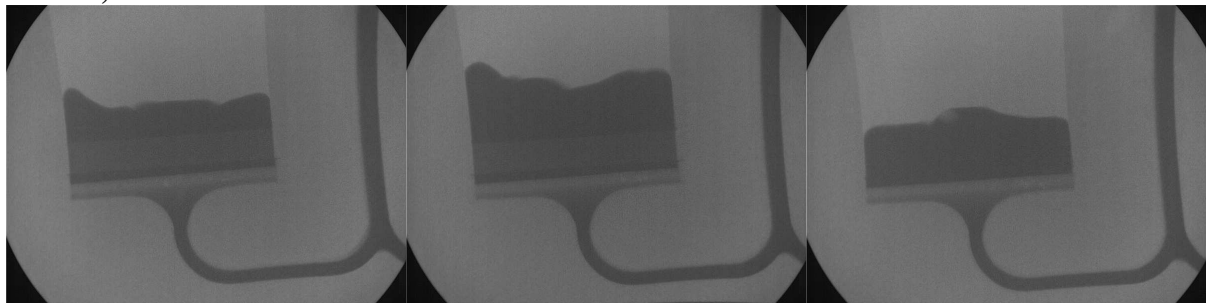
Ductile iron 4



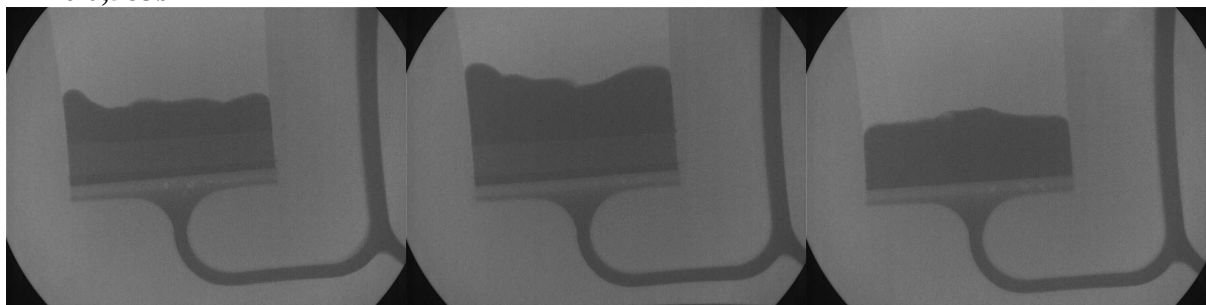
Time 0,550s



Time 0,567s



Time 0,583s



Time 0,600s

**Figure 9-4** The figure shows the frames from three of the castings.

### 9.3.1 The effect of how the melt is poured

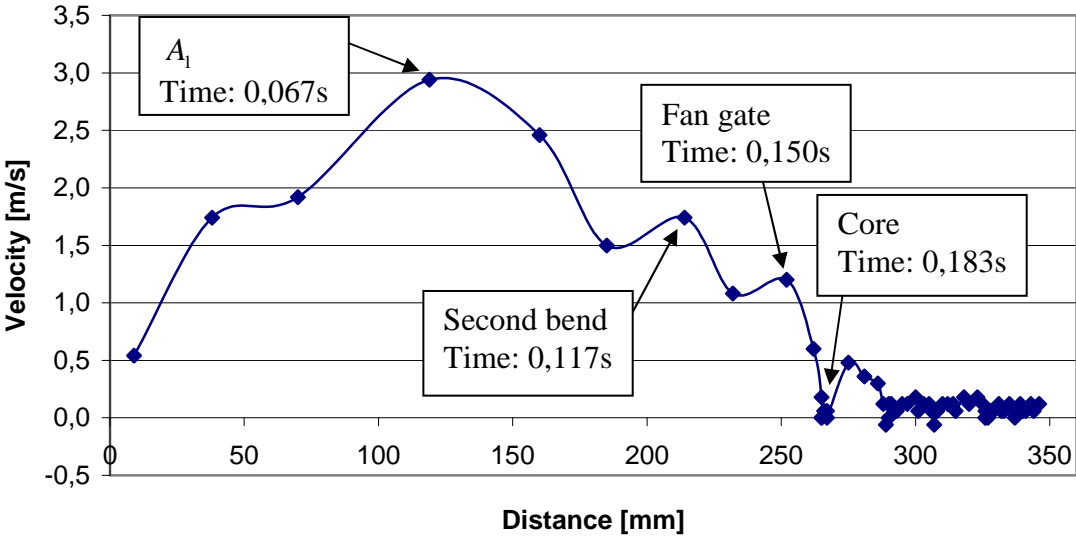
The experiments showed that even with a stopper it can be difficult with the setup presented to pull the stopper at the exact right time. This is illustrated by different flow patterns at the time when the melt enters the actual mould cavity.

As can be seen from the results of 'Ductile iron 1' and 'Ductile iron 3' presented in Figure 9-4 there is a large difference in how much the molten metal splashes when leaving the fan gate and entering the actual castings. The reason for this difference is how well the melt is poured. In the frames from 'Ductile iron 1' it is seen that the melt enters the casting calmly. At the same time it is also seen that the down runner backfills and the part of the down runner seen in the frames is not full till the time of 0,383s. When looking at the frames from 'Ductile iron 3' it is seen how the melt enters the castings with a lot more splashes which again should be seen as a result of the pouring. In 'Ductile iron 3' the pour is relatively good and the down runner is full after only 0,183s. This comparatively early filling of the down runner means that the first melt to enter the casting has a much larger momentum. The mass of molten metal behind the very first melt to enter the casting in 'Ductile iron 1' is simply smaller than the mass behind the first melt to enter the casting seen in 'Ductile iron 3'. At the same time in 'Ductile iron 3' because the down runner is full the molten metal is forced to enter the casting whereas in 'Ductile iron 1' part of the melt is used for backfilling the down runner and only the remaining melt is used for filling the casting.

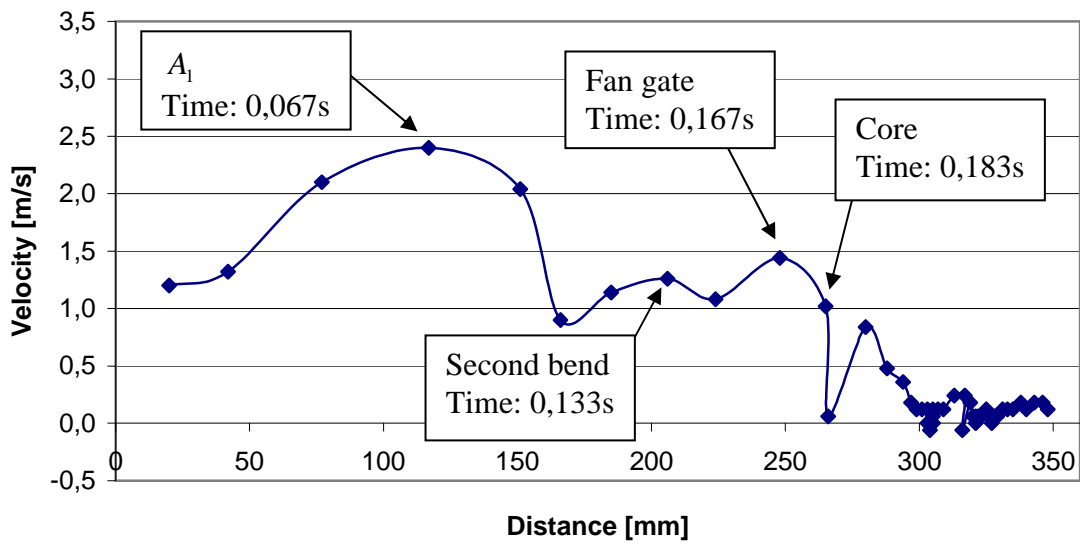
A different way of seeing the effect of how the melt is poured is to compare the velocities of the melt. In the graphs below (Graph 9-1 and Graph 9-2) the velocities have been plotted against the distance which the melt has travelled. The two graphs show that in the case of 'Ductile iron 3' where the down runner is kept full, the maximum velocity which is reached at the base of the down runner is around 2,4m/s whereas the velocity at the same place in 'Ductile iron 1' the velocity is 2,9m/s. The reason for this 0,5m/s lower velocity seen with a full down runner in 'Ductile iron 3' is due to the fact that the loss factor due to friction and surface tension is increased when the cross section of the gating system is full. When the down runner is not maintained full the molten metal is merely subjected to a free fall.

From Graph 9-1 and Graph 9-2 it is also seen that the velocity of the melt when reaching the fan gate is 0,2m/s higher in ‘Ductile iron 3’ than in ‘Ductile iron 1’. As described above this is due to the difference in momentum of the melt.

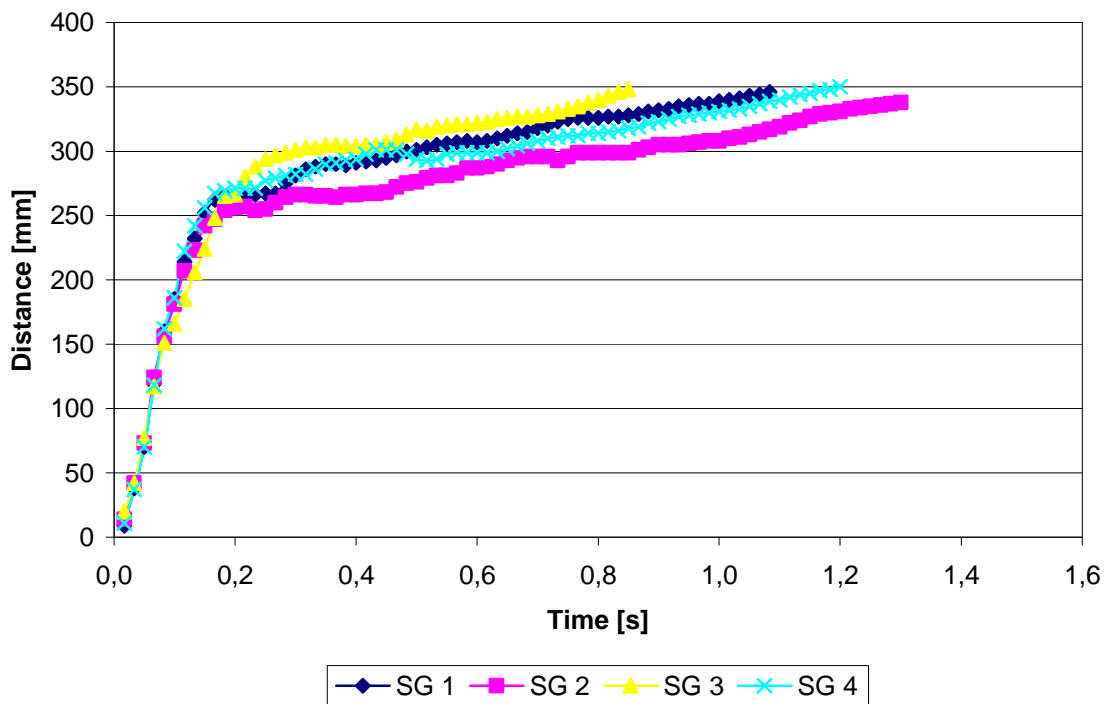
One further benefit from keeping the runner system full by pouring well is that a much higher flow rate is achieved while reducing the maximum velocity. By comparing the frames from ‘Ductile iron 1’ and ‘Ductile iron 3’ at the time 0,600s it is easily seen that more melt has entered the casting in ‘Ductile iron 3’ than in ‘Ductile iron 1’. The same is seen in Graph 9-3. In the graph the distance which the front of the melt has moved is plotted against the time. The graph underlines that ‘Ductile iron 3’ is filled the fastest. In this way the risk of cold running is also minimized.



**Graph 9-1 Ductile iron 1 - Velocity of the front of the molten metal plotted against the distance travelled**



Graph 9-2 Ductile iron 3 - Velocity of the front of the molten metal plotted against the distance travelled



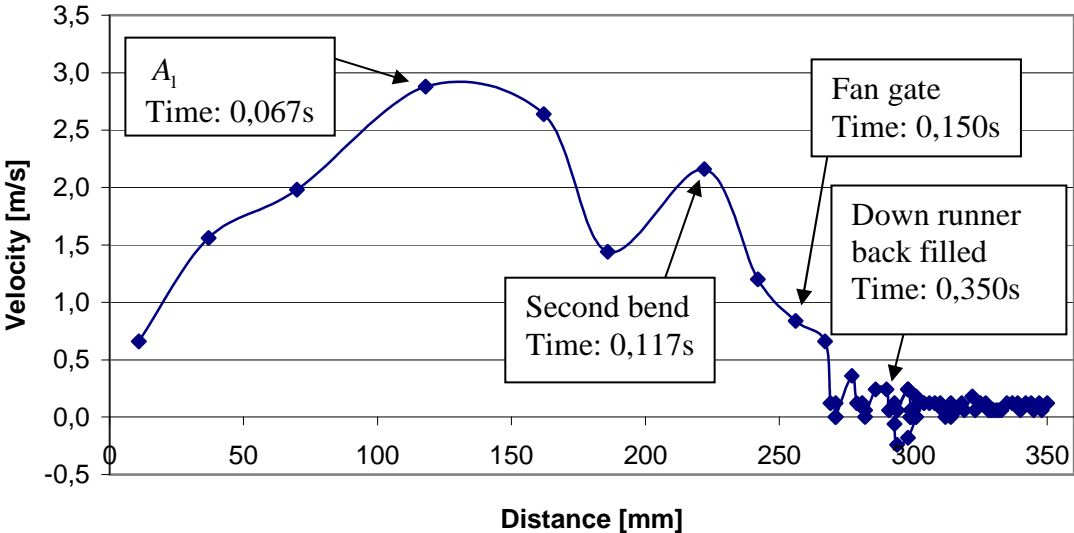
Graph 9-3 The distance which the front of the melt has moved plotted against the time for the experiments with ductile iron. Here 'Ductile iron 1' is called 'SG 1' for convenience.

9.3.2 The effect of directing the flow of metal towards a core

The purpose of placing a core just above the fan gate was to see how this would have an effect on the splashing of the initial melt.

Earlier experiments using glass plate fronted mould showed that the initial melt on entering the casting after it leaves the fan gate will form a thin plate which is then re-melted during the remaining filling. This is commonly seen in high pressure die casting. A core was then placed to try to avoid the formation of this very thin plate. In ‘Ductile iron 1’ and ‘Ductile iron 3’ the core is intact. The results from ‘Ductile iron 4’ with no core are presented for comparison in Figure 9-4.

It is seen that the down runner back fills and it takes 0,350s for it to fill. In ‘Ductile iron 4’ there is lot turbulence in the casting and the turbulence lasts for a very long time compared to ‘Ductile iron 3’. The last bubbles do not leave the melt till after 0,583s in ‘Ductile iron 4’ whereas in ‘Ductile iron 3’ the last bubbles leave after 0,417s. Part of the reason for this difference is, once again, due to the quality of the pouring of the molten metal.



Graph 9-4 Ductile iron 4 - Velocity of the front of the molten metal plotted against the distance travelled

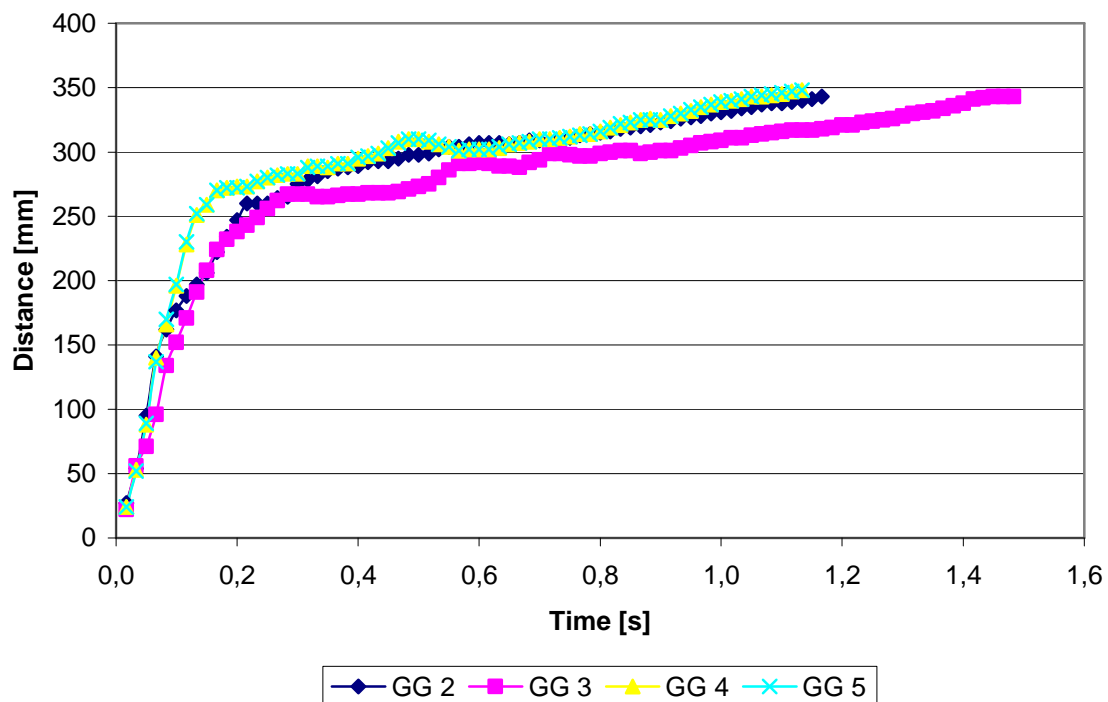


From Graph 9-4 it is seen how the velocity changes quite drastically between positive and negative right after the down runner is full. This is due to the increase in momentum of the melt when the down runner is filled as it is also described earlier.

Due to the difference in how the melt is poured it is difficult to make precise conclusions on how much the core affects the flow. However when comparing the three sets of results regarding the amount of splashing and how full the castings are at the time of 0,600s it does seem like the core has a positive effect. The splashing and turbulent filling stop much earlier when the melt is guided over a core.

### 9.3.3 Comparing the flow of ductile iron and gray iron

Previously it has been described that both a set of experiments using ductile iron and a set of experiments using gray iron were carried out.



**Graph 9-5** The distance which the front of the melt has moved plotted against the time for the experiments with gray iron. Here ‘Gray iron 2’ is called ‘GG 2’, ‘Gray iron 3’ is called ‘GG 3’, ‘Gray iron 4’ is called ‘GG 4’ and ‘Gray iron 5’ is called ‘GG 5’ for convenience.

The reason for this was to see if it is possible to actually see a difference in the flow patterns between the two alloys. In Graph 9-5 the distance the front of the melt has moved is plotted against the time for the experiments using gray iron.

When comparing Graph 9-3 and Graph 9-5 no distinct difference is seen. The results actually show that how the pouring is done has a much larger impact on the filling than the difference in alloy.

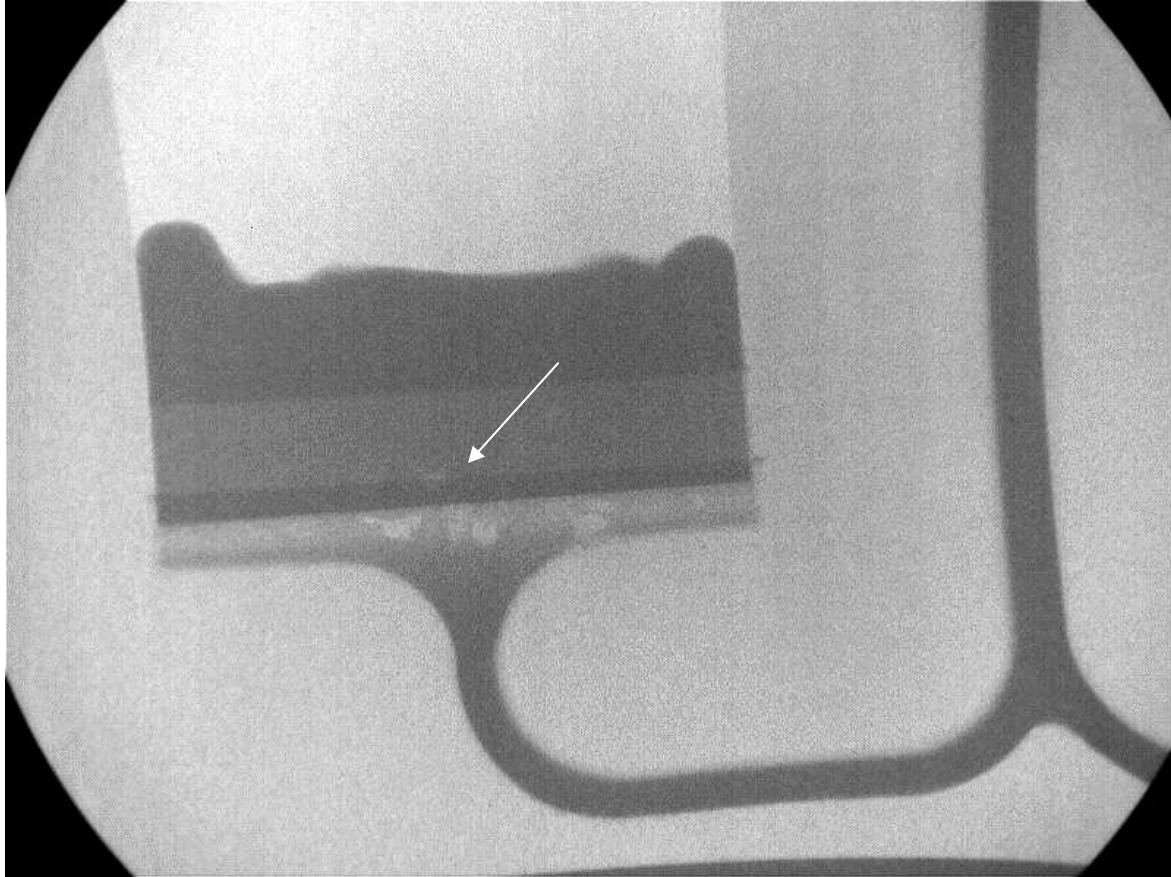
### **9.3.4 Using the in-gate for filtration**

The layout used for all the experiments using x-ray as presented above has a very thin fan gate. The fan gate is as mentioned only one millimetre thick, which is only half the thickness, tested in earlier experiments using glass plate fronted moulds. The experiments using x-ray showed in all cases very clearly how slag and dross was stopped in the fan gates. Obviously particles being too small are seen passing through the fan gates with no problems but the remaining particles are caught without seriously affecting the flow. An example is seen in Figure 9-5.

To estimate the filtration capabilities of the fan gate it is necessary to have a closer look at the pore diameter of commercially used filters. When considering pressed filters used for ductile iron the pore diameter used by the project partners, following the general recommendations, is 2,5mm. As described above the thickness of the fan gate in these experiments is only 1mm therefore one must expect that the fan gate can be equally good if not better for filtration as many filters used.

Normally the lower limit of the thickness of the in-gate is not determined by the pressure height but more likely the accuracy of mould making. When having a very thin in-gate the room for variations in for example the mould making process becomes very small. A very thin in-gate increases the sensitivity to low plasticity in for example green sand moulds. Low plasticity means an increased tendency to “springback” [Ref.

9-2] which again means that the in-gate might end up being thinner than designed and calculated and hence end up being too thin.



**Figure 9-5 Frame 42 from Gray iron 2 – particles (slag and dross) are clearly seen as brighter areas in the top of the fan gates just under the casting. The arrow indicates a small particle that did pass through.**

One benefit of using a thin in-gate for filtering is that the melt is not unnecessarily split into smaller streams as the case when using ceramic filters. When inclusions are caught in the fan gate it will not split the melt in smaller streams simply because inclusions are already surrounded by the melt. The mechanism can be compared with the flow through a conventional filter after priming.

### 9.3.5 Comparison with results from glass plate fronted moulds

One of the purposes with the experiments using x-ray was to validate how well the experiments using glass plate fronted moulds actually represents the flow of molten metal during mould filling. Therefore a number of moulds using the same pattern plate

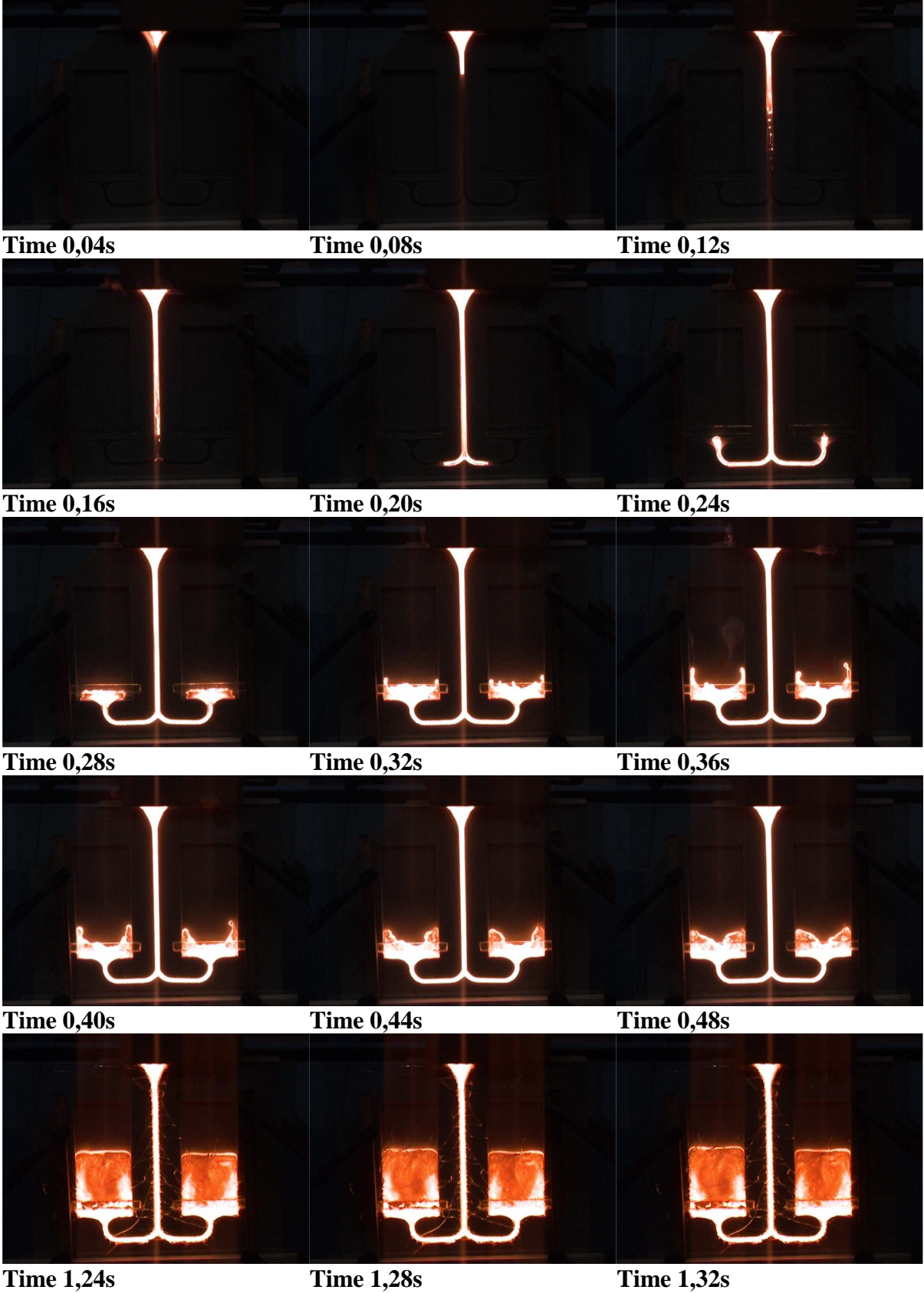
as seen at the top left in Figure 9-2 have been made. These moulds were then fitted with glass plates and a pouring basin with a stopper. Figure 9-6 shows one of these moulds.

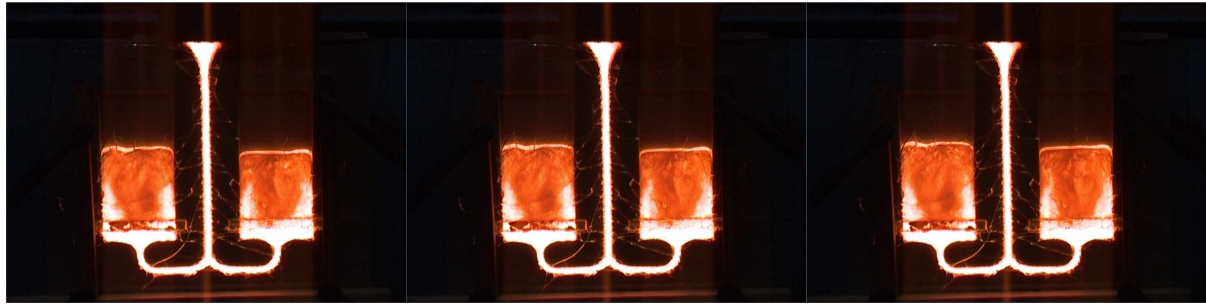


**Figure 9-6 Sand mould fitted with glass plates and pouring-basin with a stopper.**

The frames in Figure 9-7 seen below are all from the filling of one of the glass plate fronted moulds. The mould has been fitted with a core made from glass. The glass core is glued on to the glass plate. In this way the glass plate resembles the other half of the mould the most. Ductile iron is used for the experiments. The entire set of frames is seen in Appendix 5 – 14.5.4. The films from all the experiments using glass plate fronted moulds can be seen on the DVD.

Glass plate experiments – mould 1





**Time 1,36s**

**Time 1,40s**

**Time 1,44s**

**Figure 9-7 The figure shows frames from the glass plate experiments.**

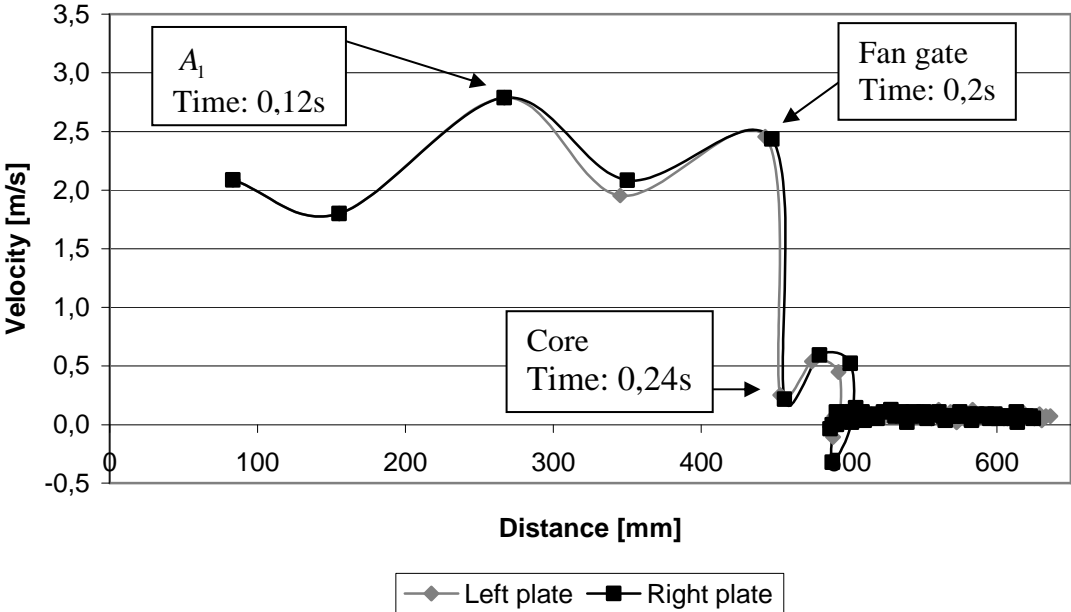
The time for each frame cannot be compared directly with the frames with the same time markings from ‘Ductile iron 1’ and ‘Ductile iron 3’. This is due to the fact that in the x-ray experiments the entire down runner cannot be seen as it can in the experiments using glass plate fronted moulds.

It is seen from the first six frames from the glass plate experiment that the down runner is completely full after 0,20s and is also kept full till the melt reaches the fan gates after 0,24s. This shows how well the pouring was performed. The difference in the pouring in the glass plate experiments here and in the x-ray experiments is that in the x-ray experiments the pouring basin was not big enough to contain all of the melt and the stopper. This meant that the pouring was started and the stopper was pulled while the last melt was poured. In the glass plate experiments the pouring basin was filled with the amount of metal needed and then the stopper was pulled.

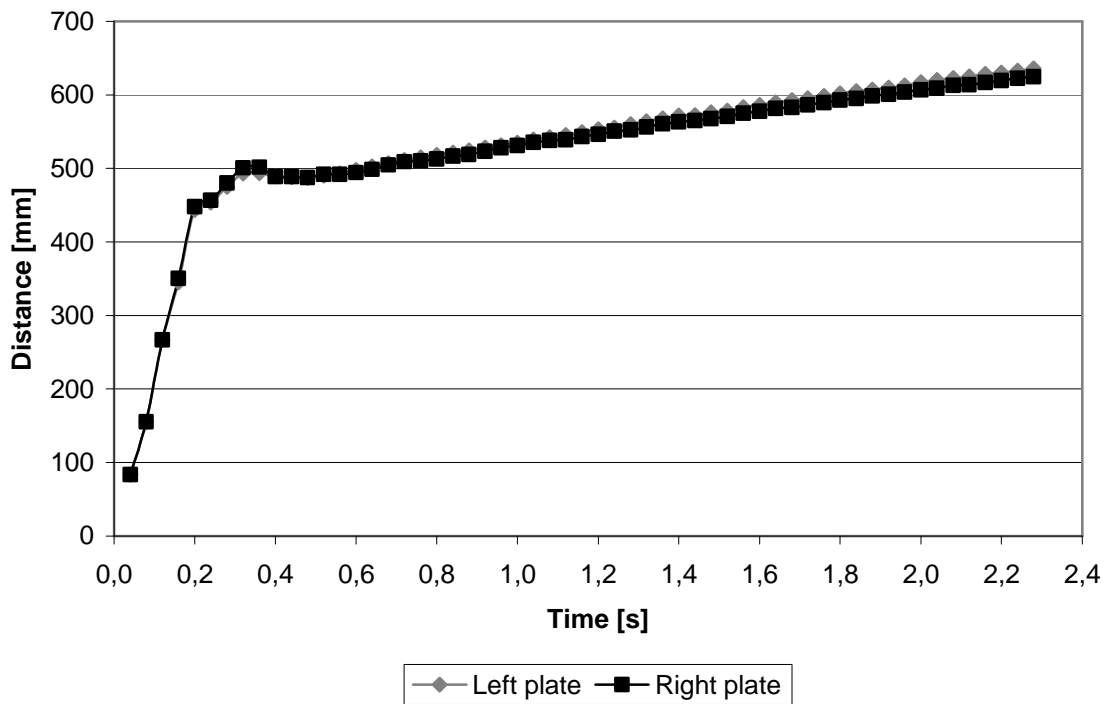
The good pouring means that the results resemble the results from ‘Ductile iron 3’ the most. When comparing the two sets of frames it is seen that in both sets the fan gates actually are a little too good at guiding the flow of metal to the sides. This means that when the metal reaches the left and right sides of the fan gates the melt jets upwards. These jets then form two waves that meet in the middle of the plate. From the colours hence temperature in the glass plate experiments it is seen that the filling of the castings continue in this way meaning that the castings are filled mostly from the sides and not the centre. In both experiments it is seen that the very first melt to enter the

mould cavity forms a very thin layer of metal in a small jet and the remaining of the filling is very calm.

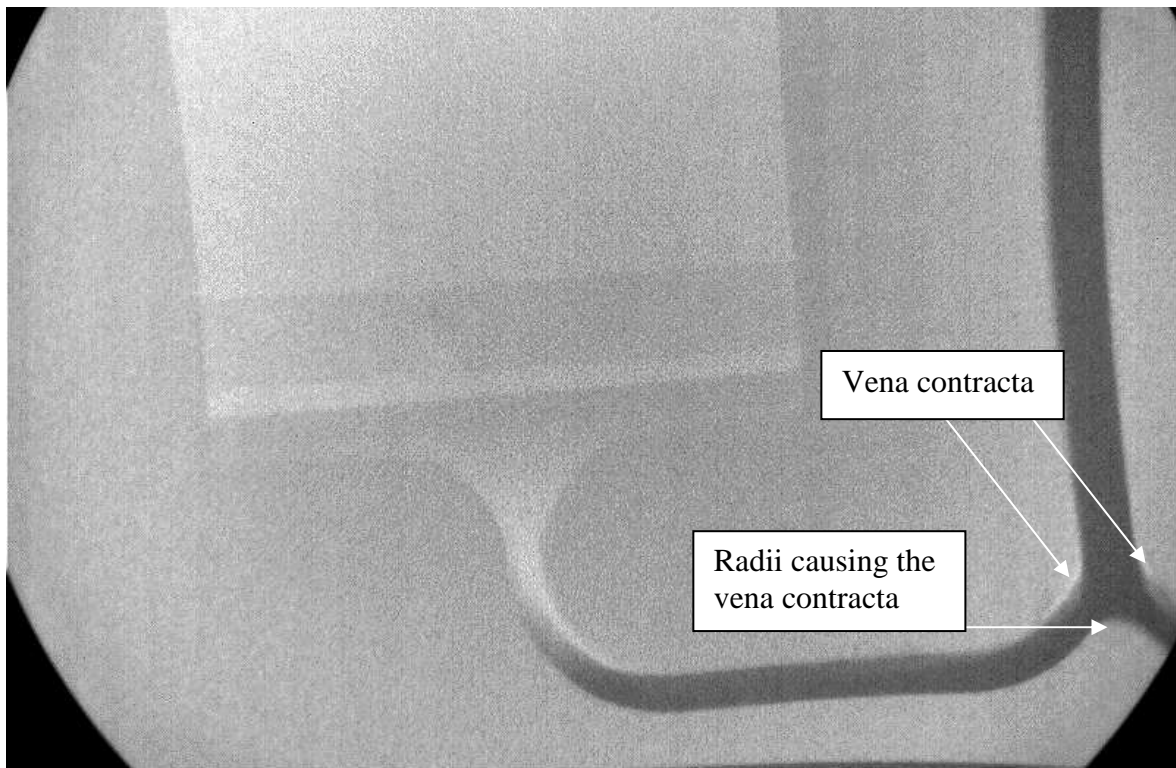
The velocity of the front of the melt is seen in Graph 9-6 and the distance the melt has moved plotted against time is seen in Graph 9-7. Comparing the velocities found here with the velocities presented for the x-ray experiments it is clear that there is very good agreement. The maximum velocity is in good agreement; the velocities by the core and for the initial small jet of metal are also in good accordance. Only the velocity at the fan gate seems very high for the glass plate experiments. In the x-ray experiments two very small vena contracta is observed in the bends under the down runner. The reason for these two vena contracta is the small radii between the two bends. In the layout this expansion in cross sectional area is not compensated for. When these volumes are filled a small pressure wave is formed adding to the velocity. In the glass plate experiments these are filled at the time the melt reaches the fan gate. The vena contracta and the radii are seen in Figure 9-8.



**Graph 9-6 Velocities in the two plates in the glass plate experiment**



**Graph 9-7** The distance which the front of the melt has moved plotted against the time for the experiment with glass plate fronted mould.



**Figure 9-8** Frame showing the small vena contracta observed in the x-ray experiments. The reason for the vena contracta is the small radii between the two bends not compensated for.



### 9.4 Conclusions

The experiments clearly demonstrate how important it is that the melt is poured so that the top of the down runner is maintained full from the very beginning to the very end of the mould filling. If this is not the case it is not possible to keep the rest of the gating system full and back filling occurs. The maximum velocities are also lowered when the down runner is full because the loss factor in this way is increased.

The experiments also revealed that the small radius between the two bends under the down runner is enough to cause vena contracta on the inner side of the bends. The radius between the two bends is to avoid erosion of sand. Having this radius it is necessary to compensate on the inner side of the bends to avoid the problem. This problem underlines the importance of being sure that all cross sectional areas are dimensioned correctly, but also that any sudden expansions in the runner system will cause problems.

Experiments were conducted for both ductile iron and gray iron to investigate the difference in flow properties between the two alloys. However it was found that how well the pouring was done has a much larger impact on the mould filling than the difference in alloys.

In the layout for these experiments the fan gates ended in a thickness of only one millimetre. The experiments revealed that this very thin section works as a filter. In all of the experiments it was clearly seen how slag and dross was caught in the fan gate just before entering the casting.

A comparison of experiments using x-ray and the experiments using glass-plate fronted moulds was done. This comparison proved that glass plate fronted moulds resemble the actual flow pattern in a complete mould very well. The difference in heat

conductivity and surface roughness between the glass plate and a sand mould does not have a significant influence on the flow patterns observed.

## References

**[Ref. 9-1] E. A. Herman, Gating Die Casting Dies, North American Die Casting Association (NADCA), 1996**

**[Ref. 9-2] DISA Application Manual**

## 10 Streamlined gating systems in horizontal moulding

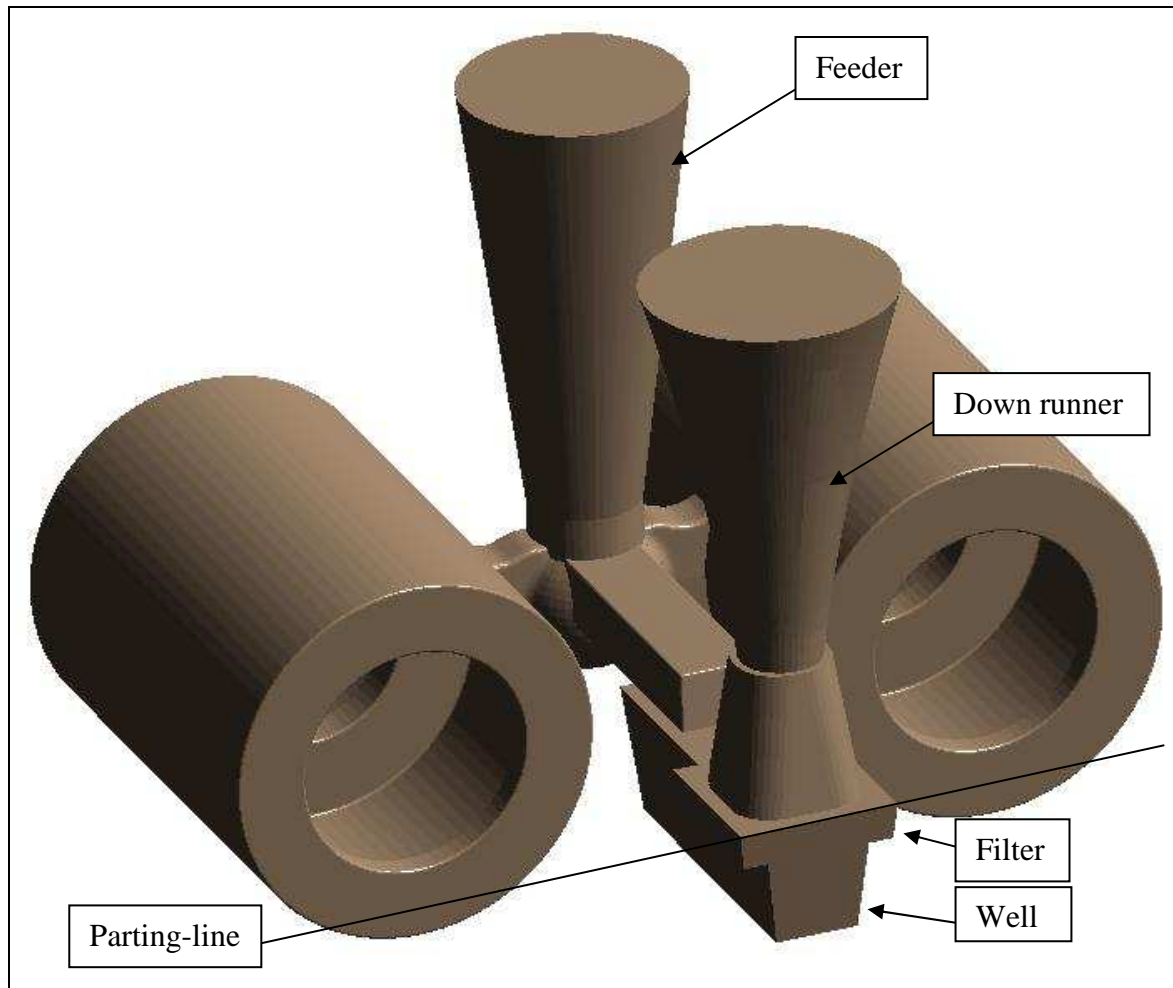
In all the experiments previously described in this project only layouts for vertically parted moulds have been considered. It is of great importance to investigate how to use the principles in horizontally parted moulds. A layout for a valve-housing very similar to the case study has been made for this purpose. The only difference between the two valve-housings is the diameter of the housing. The outer diameter of the case study is 100mm whereas the outer diameter of the valve-housing in these experiments is 131mm. The same type and size of valve is used in both cases. The valve-housing here has not been optimized the way the valve-housing in the case study was. The material for the castings in these experiments is a bronze-alloy. The facilities for these experiments are described in the chapter 'Experimental facilities' - 'Facilities at Frese Metal- and Steel Foundry A/S'.

### 10.1 The layouts

#### 10.1.1 The traditional layout

A schematic representation of the traditional layout is seen in Figure 10-1. One part of the geometry shown here is not completely accurate. The feeder is in reality shaped by an insulating sleeve.

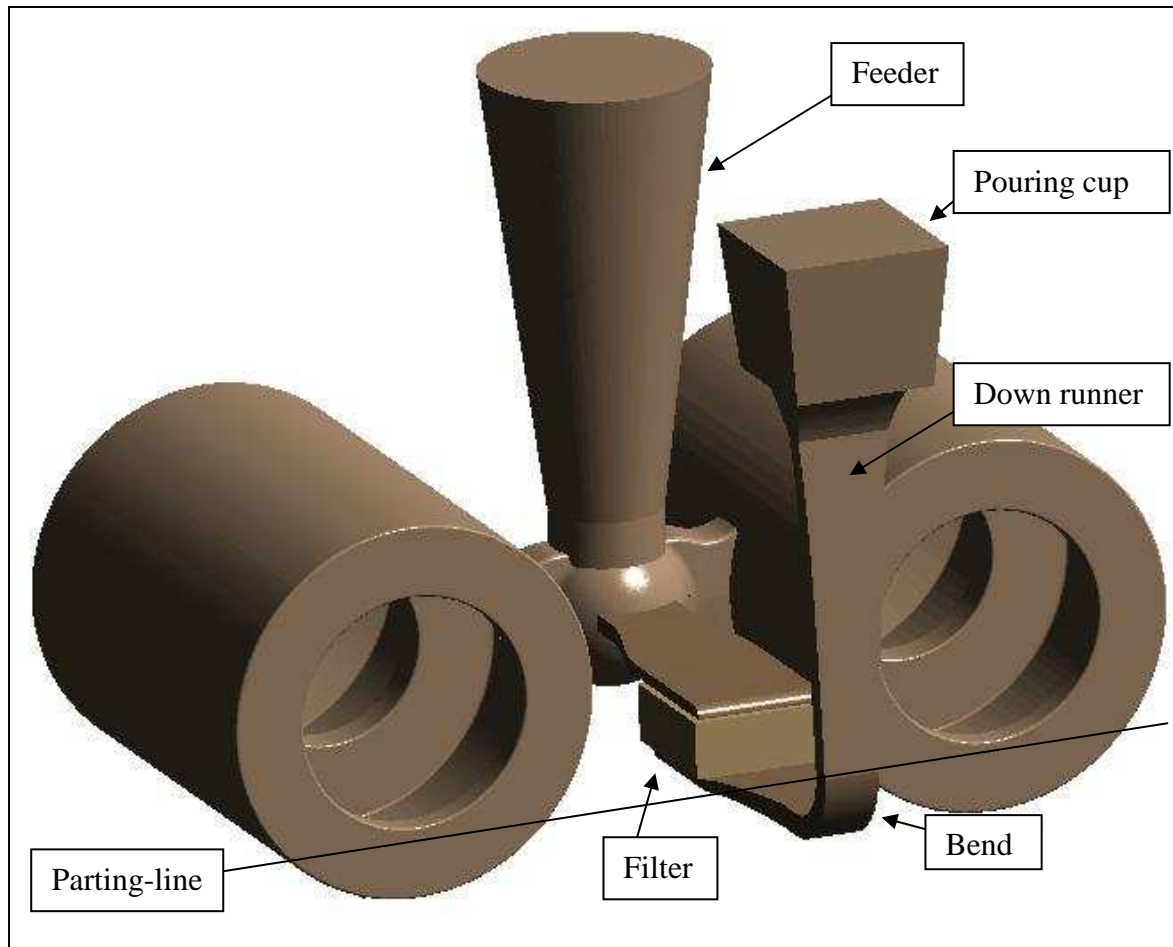
In the traditional layout the filter is placed horizontally in the drag at the base of the down runner. A small expansion of the cross-sectional area in the lower part of the down runner is used to accommodate the filter. Below the filter a large well is seen leading to a short horizontal runner in the cope. The horizontal runner leads to the warm feeder, which is feeding both valve-housings.



**Figure 10-1** The traditional layout for two valve-housings cast in bronze.

### 10.1.2 The streamlined layout

The streamlined layout is seen schematically in Figure 10-2. The feeder has been re-used from the traditional layout in the streamlined layout. This means that also in Figure 10-2 the shape of the feeder is not accurate. The remaining part of the gating system is accurate however.



**Figure 10-2** The streamlined layout for two valve-housings cast in bronze.

The major differences between the traditional layout and the streamlined gating system are the use of a bend below the down runner re-placing the well in the traditional layout combined with the new placement of the filter. In the streamlined layout the melt flows underneath the filter and then up into a horizontal runner in the cope before entering the feeder. The dimensions of the streamlined gating system are seen in Figure 10-3 without the feeder.

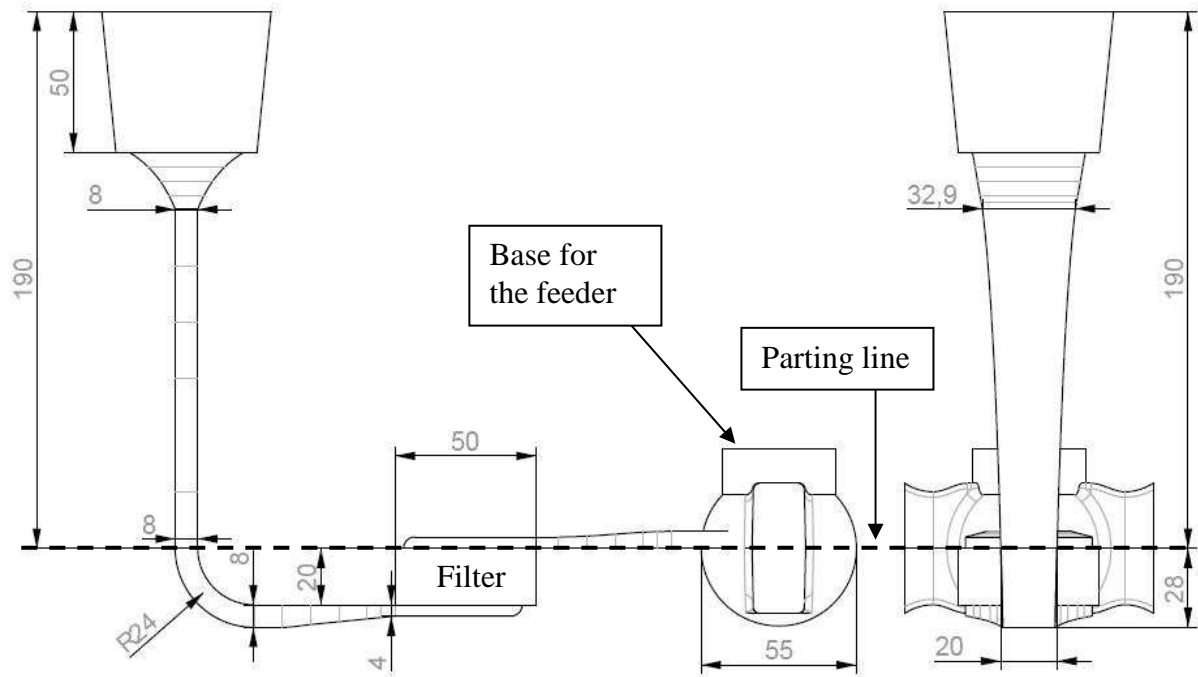


Figure 10-3 The figure shows drawings and dimensions of the streamlined gating system.

## 10.2 The moulds

Moulds have been made using the streamlined layout. Figure 10-4 shows the drag from one of the moulds prior to the assembly. Figure 10-5 shows the drag after the cores and the filter are positioned.

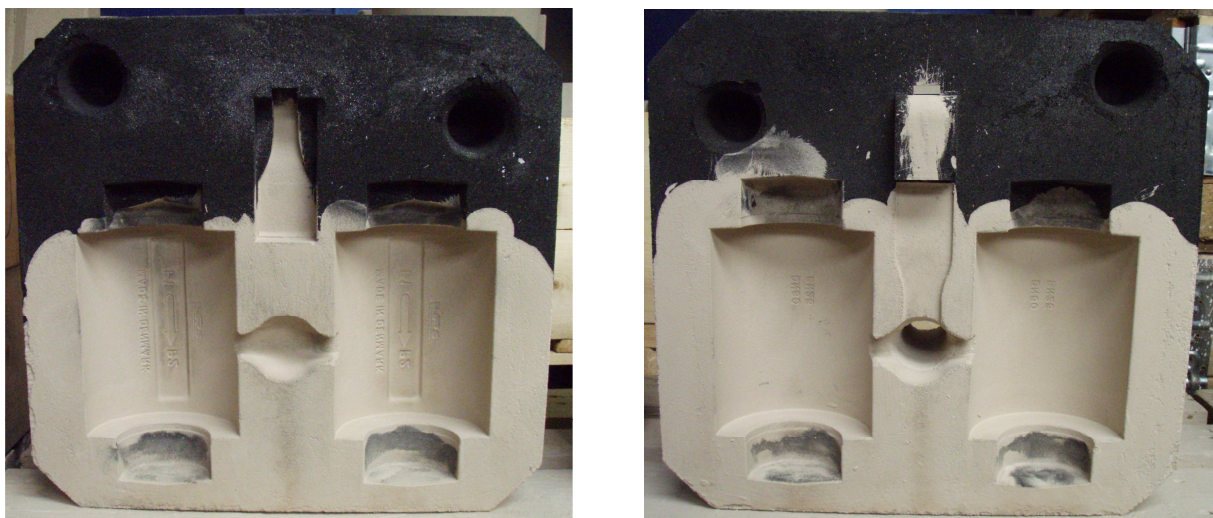
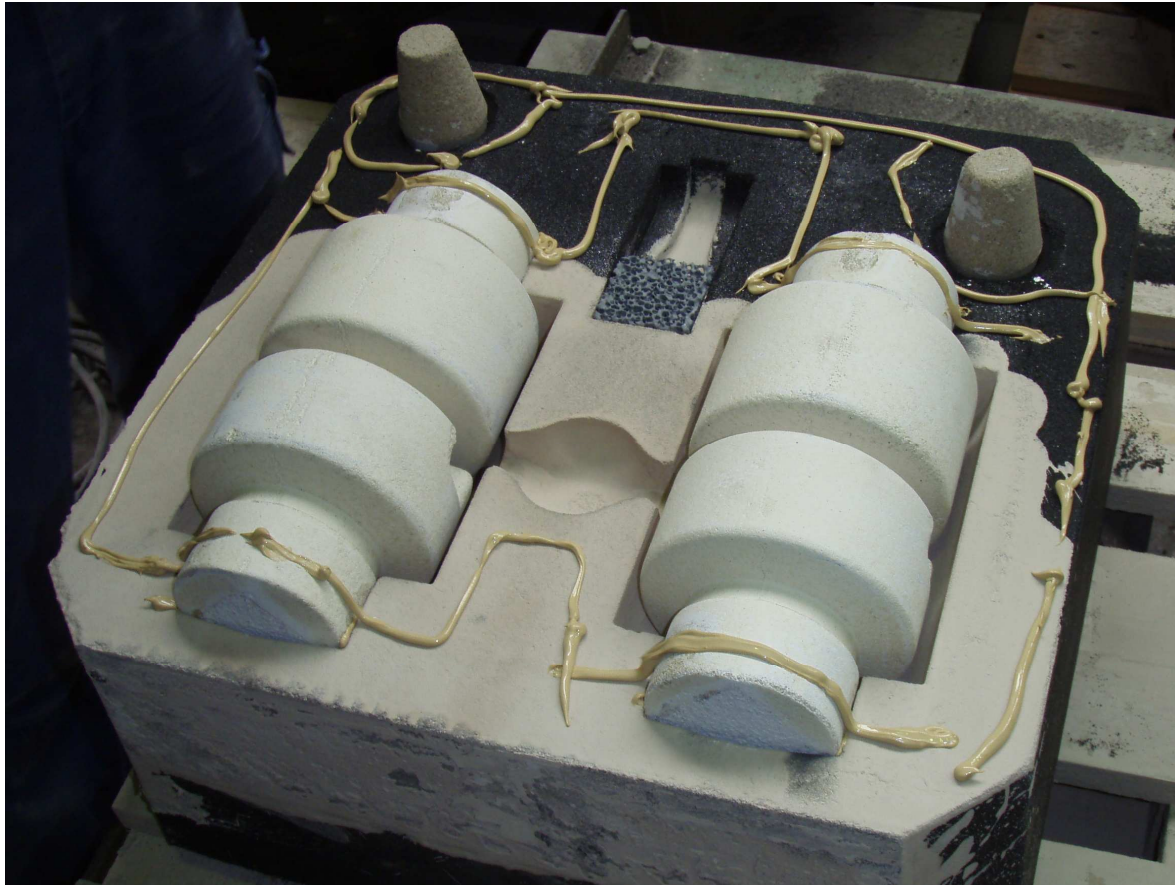


Figure 10-4 The two pictures show one of the moulds for the experiments. To the left: the drag. To the right: the cope.



**Figure 10-5** The picture is showing the drag prior to assembly. The cores and the filter are positioned.

### 10.3 Results

Five moulds were cast in total. Three of the moulds were fully cast and two of the moulds ended up as cold-runs. The two cold runs are seen in Figure 10-6. It is seen that the filling in the two cases stopped at almost the same place in the gating system.

The reason for the cold runs was that it proved difficult in practice to line up the ladle in the crane precisely for pouring in the small pouring cup. Due to this, the top of the down runner was in two occasions not maintained full during the pouring resulting in the cold runs. The remaining three moulds were fully cast. An example is seen in Figure 10-7.





**Figure 10-6** The picture shows the two cold runs from the experiments



**Figure 10-7** An example from one of the fully cast moulds.

### 10.3.1 Reduction in the poured weight

As it was described the feeder in the traditional layout was reused in the streamlined layout. Due to this the change in the poured weight is only found in the remaining gating system. The weight of the two layouts is seen in Table 10-1.

Traditional layout: weight of gating system	Streamlined layout: weight of gating system
6,2kg	2,5kg

**Table 10-1 Poured weight of the gating systems.**

The reduction in the poured weight is found to be 3,7kg.

## 10.4 Conclusions

The experiments proved that it is possible to use the principles in the streamlined gating systems for horizontal moulding. It was also proven that using the streamlined gating system even for relatively small castings a large reduction in the poured weight of 3,7kg is achieved.

The problem of cold runs can be avoided if the size of the pouring cup is increased. In this way it is easier to pour the melt correctly. This underlines, as earlier described, that the design of the pouring cup should accommodate the facilities and practice in the individual foundry.



## 11 Potential energy savings

The main purpose of this project is to develop gating systems that can reduce the amount of metal to be re-melted so that the over all amount of energy needed in foundries is reduced. One way of finding out if this goal has been achieved is to weigh a traditional and a streamlined layout and see the weight difference. However this does not give the full picture of the potential energy savings found in this work. A more full description is found in the following.

### 11.1 Reduction in the poured weight

In the chapter ‘Casting of a valve housing’ two layouts were compared. Here it was found that when comparing the weight of the gating system meaning the poured weight without the castings and the feeders 1,1kg was saved. In the chapter ‘Streamlined gating systems in horizontal moulding’ it was found in the same way that 3,7kg was saved. This is a 60% decrease in the weight of the gating system. The energy consumption for melting one kg of metal is seen in Table 11-1. The value for bronze is based on the assumption that the yield is 50%. The actual energy saving based on the values in Table 11-1 is seen in Table 11-2.

	Iron	Bronze
Energy consumption in total	1,194 kWh/kg	6,800 kWh/kg

**Table 11-1 [Ref. 11-1] Energy consumption per kg melted.**

	Vertical layout	Horizontal layout
Energy saved per mould	1,31 kWh	25,16 kWh

**Table 11-2 The energy saved for melting in the two layouts only considering the gating systems.**

To get a better idea of what these energy savings mean in a production line the layout for the vertically parted moulds is looked at. The layout is for a Disamatic that can produce around 350 moulds an hour for castings with cores. This means reduction in the energy consumption of 460kWh per hour and 3680kWh per eight hour work day.

It should be mentioned that in Denmark in 2006 foundries in total produced 78565 tons of iron castings and 813 tons of bronze alloys. In this perspective the energy savings seen in Table 11-2 shows a very large potential for energy savings. The real potential for the individual foundry depends heavily on a whole range of parameters especially the size of the castings and the demands for the mechanical properties. This means that the potential shown here might be higher than what many foundries will achieve.

It is impossible to say an exact decrease in the poured weight when changing from the traditional to the streamlined gating system in general. But a few obvious savings should be mentioned. The streamlined gating system has no dead ends like the traditional layout often does and also the weight of the well are saved in the streamlined layout. By using bends with radii as large as possible in the layout the runners will be shorter than in the traditional layout having 90 degree bends also leading to savings. Often in traditional layouts the cross-sectional area in the horizontal runners are much larger than the governing area in the down runner. In the streamlined gating system no cross sections are larger than necessary hence saving metal.

One part of the traditional gating system where large reductions in the poured weight can be obtained is in the use of filters and filter prints. In the chapter 'Filtration' it was shown that ceramic filters should only be used for filtration and not for controlling the flow of metal. This means that if it is not possible to clean the melt before pouring, a filter should be placed above the funnel in the streamlined gating system. The reason for this is that it is the only place in the gating system the filter can be placed without the use of large unnecessary volumes for filter prints. It has been shown that by not having filter prints around 600g of metal can easily be saved in every mould.

### 11.2 Reduction in scrap rate

When using the traditional gating systems the flow pattern during mould filling is highly inconsistent meaning that the flow pattern changes from one mould to the other. [Ref. 11-2] This can lead to unexplainable problems and is not easy to simulate either.

The glass plate experiments in this project have shown that streamlined gating systems give very consistent flow patterns during mould filling. This means also that it is much easier to reduce the scrap rate. When having a consistent flow pattern during filling it is also more likely that the problems occurring becomes more consistent, and hence making it easier to pinpoint the exact reason for the problem, and based on this find the right solution to solve it. A problem could be that a feeder dimensioned according to theory is sometimes large enough and some times not when using a traditional layout even with a consistent pouring temperature. Many foundries would solve this problem by simply increase the size of the feeder. This obviously increases the weight poured and reduces yield. The flow pattern during mould filling has an effect on the temperature of the feeder but obviously also an effect on the temperature of the casting. This means that the need for feeding varies and the efficiency of the feeder varies as well. Using the streamlined gating system with a much higher consistency in the flow pattern this kind of problem is not likely to occur. Either the feeder is sufficient or it is not. This also means that it is possible for the foundry to reduce the safety margin when designing feeders hence improving yield.

### 11.3 Potentially no heat treatment

Using streamlined gating systems with fan gates to give a beneficial heat distribution in the castings may be an efficient tool to eliminate the need for heat treatment. In the experiments described in the chapter 'Casting of a valve housing' the change in gating system from the traditional layout to the streamlined layout removed the need for heat treatment. This obviously means a huge energy saving in the foundry. The energy consumption for heat treatment of iron has been found to be 0,489kWh/kg. [Ref. 11-1] The valve housing in the case study weighs 3kg so when the need for heat treatment is

removed around 1,5kWh is saved per casting. Along with the reduction in energy used the foundry also save the cost of handling the castings for the heat treatment and the production time is reduced considerable.

### 11.4 Lower pouring temperature

In most iron foundries a pouring temperature of around 1400°C is desired. Lowering the pouring temperature normally means problems with cold runs. In the chapter 'Casting of a valve housing' it was shown that it is possible to cast the valve housing with a predominant wall thickness of 5mm at a pouring temperature of 1268°C. There are many very different benefits if this potential is used. Some of these are mentioned here:

- Energy saving for melting.
- Energy saving for holding furnace (if a holding furnace is used)
- Reduced potential for loss of heat during transportation and pouring.
- Reduced evaporation of carbon.
- Reduced evaporation of magnesium.
- Reduced need for feeding.
- Reduced cooling time hence reducing the need for long cooling strings.
- Reduced wear on refractory lining in furnaces, ladles and pouring device.

#### 11.4.1 Energy savings

To get an indication of how much electrical energy that potentially can be saved by reducing the pouring temperature by 100°C the following example based on energy values from literature may be useful. Earlier experiments have shown that in a one tonne full induction furnace the energy required to raise the temperature from 1400°C to 1500°C is 54,6 kWh at 750kW and 42,2 kWh at 500kW. [Ref. 11-4] These results give an approximation of the amount of electricity that can be saved. However the

potential for energy saving may be even larger. This is due to the fact that the higher the temperature is the more energy is lost. The explanation follows here:

The reduction in temperature will help save energy throughout the entire casting process. In the calculation above the energy saving for melting was looked at but apart from energy used for melting less energy will be used for holding and transporting. The reason is that the temperature is the driving force for the heat loss or energy loss. The equation for the conduction of heat in its basic form is seen in Eq. 11-1 [Ref. 11-3].

$$\text{Eq. 11-1} \quad q = -kA \frac{\partial T}{\partial x} \quad (\text{Fourier's law})$$

Where

$q$  is the heat flux [W]

$A$  is the area of the surface [m<sup>2</sup>]

$k$  is the thermal conductivity [W/(mK)]

$T$  is the temperature [°C]

$x$  is the descriptive space parameter perpendicular to the surface [m]

Normally the thermal conductivity may be considered constant within a reasonable temperature interval. From the equation it is clearly seen that the temperature being the only variable has the major influence on the amount of energy lost per time. The time it takes for the melt to come from the furnace and to the actual pouring will obviously be the same and therefore because the energy loss per time is less the overall energy loss becomes comparatively less as well. This means that in theory to have a pouring temperature of 1400°C requires a larger superheating than to have a pouring temperature of only 1300°C. In other words there is a potential for lowering the superheat by more than just 100°C when lowering the desired pouring temperature by 100°C. However in practice many parameters have an influence so it is difficult to say



exactly how much energy that can be saved in a foundry but the potential is substantial.

### 11.4.2 Further benefits

A reduced pouring temperature will lower the potential for the evaporation of both carbon and for ductile iron also magnesium from the melt. This means that it takes longer for a certain amount of carbon and especially magnesium to evaporate. Combined, this means easier control of the composition of the melt before pouring. It also means that the holding time from magnesium treatment to pouring is increased. Normally if for some reason a delay occurs and it takes too long from the time of the magnesium treatment and till the time of pouring too much magnesium evaporates and it is necessary to empty the pouring unit. The metal will then be returned to the furnace. By prolonging the time the melt can hold the amount of metal to be re-melted is reduced.

The need for feeding also becomes slightly smaller by reducing the pouring temperature. The thermal contraction of the molten metal is not always seen as a problem because it is easy to compensate for. [Ref. 11-5] However this is only the case if there is still access to the gating system or a feeder is present. The thermal contraction of molten gray- or ductile iron can be approximately 1,7% per 100°C. [Ref. 11-6] In this perspective the need for feeding is actually reduced by 1,7% by lowering the pouring temperature by 100°C.

In many foundries the space for keeping the moulds when cooling after the pouring is an issue. Lowering the pouring temperature reduces the time for cooling and solidification and will therefore also be beneficial here.

Finally a lower temperature will reduce the wear on the refractory linings in both furnaces and ladles hence prolonging the lifetime of these. Changing especially the

refractory linings in the furnaces is both time consuming and expensive so to reduce the wear here will be an economical benefit.

### **11.5 Possibility for foundries to offer more thin walled castings**

In the previous all the benefits and energy savings by lowering the pouring temperature were mentioned. However the potential for casting at a much lower temperature can also be used in a very different way. The fact that it is possible using streamlined gating systems to lower the pouring temperature or avoid problems with cold runs also makes the foundry capable of offering much more thin walled castings to their customers. Many foundries have a lower limit to how thin walled castings they are willing to attempt to cast for their customers. However by using the streamlined gating systems it is possible to lower this limit. Especially the automotive industry continuously asks for lighter castings so there is a huge potential market for a foundry specialized in thin walled castings. It could be argued that the streamlined gating systems in this way can help reducing the energy consumption in cars hence reducing the over all use of energy.

## References

**[Ref. 11-1] Crepaz, R – Renere produkter i støberibranchen, delprojekt 1, 1.1 ”Indsamling og vurdering af eksisterende data”, J.nr. M126-0428, november 2002**

**[Ref. 11-2] Larsen, Per – Iron Melt Flow in Thin Walled Sections Cast in Vertically Parted Green Sand Moulds. Technical University of Denmark 2004**

**[Ref. 11-3] Hattel, Jesper – Fundamentals of Numerical Modelling of Casting Processes, 1. Edition 2005, Polyteknisk Forlag, Kgs. Lyngby, Denmark**

**[Ref. 11-4] Smith, L. and Bullard, H.W. – Best Melting practices in medium frequency coreless induction furnaces, The Foundryman, July 1995**

**[Ref. 11-5] Campbell, John – Castings, second edition. Elsevier Butterworth-Heinemann, 2004**

**[Ref. 11-6] Sillén, Rudolf V. – Gating and Feeding Iron Castings, Foundry Management & Technology, may 1997**

## 12 Discussion

### 12.1 First melt entering the casting

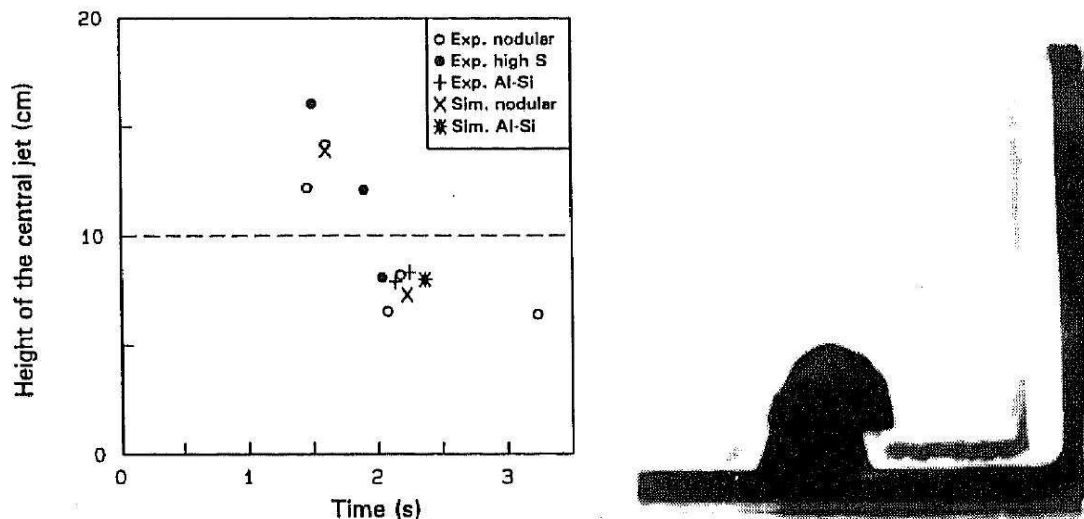
In all of the experiments using streamlined gating systems a jet of the initial melt is seen to enter the casting. The jet is seen as a thin coherent layer of melt that enters the mould and then drops again. In some of the experiments using glass plate fronted moulds the thin jet is seen to solidify against the glass. Whether the melt drops or solidifies depends on how severe the jet is. If the jet is large the risk of it solidifying is also larger than if the jet is smaller. Obviously there is also a risk of oxide formation associated with a jet like this.

The extent of the jet depends on the momentum of the melt. If a streamlined gating system is used and the pouring is done so that the entire gating system is maintained full the melt has the full momentum at all times also when entering the casting. This means that a jet is seen right away but from then on the mould is filled calmly. A very different flow pattern is seen when using a gating system, which is not kept full. If the down runner and/or horizontal runner backfills the result is a very small jet for the initial melt. This jet is followed by another jet created when the gating system is finally back filled creating a pressure wave. In the case that the gating system is backfilled simultaneously with the first melt entering the casting the resulting jet is intensified. These effects were seen in the experiments regarding filtration.

The experimental results that show these influences on the flow pattern from pressures that build up instantaneously underlines the importance of avoiding geometries in the gating system that creates such pressures. The traditional gating systems are full of such geometries. Examples are sudden increases in cross-sectional areas and having a dead-end in runners. The sudden increase in cross-sectional areas is often seen in the transition from the down runner to the horizontal runner. Designs like this ensure sudden pressures forming when the runners are finally filled. Dead-ends in the

horizontal runner result in a build-up in pressure when filled, forming a jet into the mould cavity.

In previous chapters the shape and behaviour of the initial jet in streamlined gating systems were described. Earlier experimental work has proven in more traditional gating systems that the jet of first melt that enters the casting has the shape of a mushroom. [Ref. 12-1] The height and the shape of these mushroom-shaped jets are seen in Figure 12-1. The results show that the height of the jet is approximately five to fifteen centimetres.



**Figure 12-1 [Ref. 12-1] To the left: Graph showing the height of the initial jet of melt in traditional gating systems observed in experiments and in simulations. To the right: Typical stage during mould filling.**

The largest jet observed in all of the experiments where plate shaped geometries were cast, was seen in the experiments in the chapter 'Runner width'. In the results presented in this chapter the jet is found to have a height of 8,1cm. This result is seen to be well within the range of the values of the traditional gating system. It is important to remember however that the gating system in the chapter 'Runner width' is designed for a much shorter pouring time than normally recommended. As it was mentioned the pouring time should have been three and a half times longer considering size and wall thickness of the casting. In the experiments using x-ray the jet in 'Ductile

iron 3' was found to be 3,8cm and for 'Ductile iron 4' 3,4cm. These values are well below any of the values seen in Figure 12-1. This is a clear indication that using streamlined gating systems decrease the jets and turbulence of the initial melt entering the casting compared with the traditional gating systems.

## 12.2 Velocities during mould filling

Most of the experiments in this project have been done with ductile iron or grey iron. These alloys are not known to be especially sensitive to oxide formation and gas entrapment relative to other alloys like aluminium-bronze. The reason is the graphite in cast iron that has a very low strength when compared with the ferrite and pearlite. The tendency for oxide formation in ductile iron is also very limited due to the carbon content. The carbon reacts instead of iron with oxygen and thereby prevents other oxide formation. Smaller spherical gas porosities in ductile iron can be seen as graphite nodules and therefore do not decrease the mechanical properties considerably. This is not the case for castings in other alloys where the mechanical properties are closely linked with the soundness and the amount of oxides in the material. A general guideline for these more sensitive alloys is that the velocity should not exceed 0,5m/s in the in-gates. [Ref. 12-2] However if it is harmful to the melt to exceed 0,5m/s inside the casting it must be just as harmful if the melt exceeds 0,5m/s in the gating system or anywhere else. In this perspective this rule can never be fulfilled. The maximum velocity of the melt is determined by gravity and is found at the base of the down runner. Using the equations presented in the chapter 'Theory in gating technology' the maximum height the molten metal is allowed to fall can be calculated using Eq. 12-2.

$$\text{Eq. 12-1} \quad v = \sqrt{2 \cdot g \cdot H}$$

⇕

$$\text{Eq. 12-2} \quad H = \frac{v^2}{2 \cdot g} = \frac{(0,5\text{m/s})^2}{2 \cdot 9,82\text{m/s}^2} = 0,013\text{m} = \underline{\underline{13\text{mm}}}$$

If the general guideline is to be followed the melt is only allowed to fall 13 millimetres. For iron and dense alloys the critical velocity is only 0,4m/s leading to a

maximum height of only 8 millimetres. [Ref. 12-2] Obviously from a practical point of view this can never be fulfilled. The pouring from the ladle into the pouring cup alone results in a fall higher than 13 millimetres. In the case of casting slightly complex geometries the melt might have to fall more than this inside the casting during the filling. As it was just discussed the initial jet of melt in the casting is many times higher than these 13 millimetres. Still it is possible to produce high quality castings using principles from the traditional gating systems including filter prints and straight tapered down runners and 90° bends in the runner system. When including all of the non-beneficial effects these types of gating systems have been proven to have on the flow pattern this should not be possible.

In all, this means that these alloys perhaps are not quite as sensitive to oxide formations and gas entrapments as commonly believed. It also means that using the principles of the streamlined gating system for these alloys can be very beneficial for the quality of the castings. After all it has been proven that the streamlined gating systems reduce turbulence, vena contracta, and gas entrapment in the gating system. Also the initial jets have been proven to be less. Finally the mean velocity during mould filling, not taking the initial jet in to account, is only around 0,09m/s in the experiments in the chapter 'Runner width'. This velocity is only one fifth of the recommended velocity even when having a pouring time three and a half times shorter than recommended.

### **12.3 Changing to the streamlined gating systems**

In this project a complete set of guidelines and a spreadsheet for the use of streamlined gating systems have been presented. Along with the guidelines, a set of standard geometries for the streamlined gating system have also been presented. With these tools in hand it should be a lot less complicated for a foundry to use the streamlined gating systems, and hence profit from all the benefits. However there are still considerations to do before all the benefits can be achieved.

### 12.3.1 Pouring cup and funnel

To start using the streamlined gating systems it is necessary to make a set of new standard geometries. Considerations in this regard involve whether the existing pouring cup from the traditional gating system needs redesign, and how the shape and size of the pouring cup influence the dimensions for the standard geometry of the funnel.

It has been reported that the use of the funnel improves the pressure height relative to using the filter print seen in the traditional layout in the chapter 'Theory in gating technology'. This means that for a vertically parted mould it is possible to position the castings higher on the pattern plates. This is important to remember when the casting is either close to the maximum size for the pattern plate, or when it is necessary to position the castings high to make room for a the gating system below the casting.

### 12.3.2 Lowering of the pouring temperature

One of the major benefits using the streamlined gating systems is the possibility of lowering the pouring temperature. To do this it is necessary that all the layouts used for the batch of melt is made using the streamlined gating systems. If this is not the case cold runs would be expected for all castings using the traditional gating systems. Foundries having a large amount of different sets of pattern plates will therefore find it difficult to lower the pouring temperature till at least a number of layouts or layouts used for long series have been done using the streamlined gating systems. One way of achieving this number of layouts is by replacing already existing and functioning traditional gating systems. This solution is obviously very cost extensive and can in most cases not be recommended. Another solution is to use the streamlined gating systems for all new layouts and then in time the layouts most commonly used will all have streamlined gating systems. In this way it takes time but eventually it will be possible to lower the pouring temperature. In the mean time the use of streamlined gating system will mean a considerable reduction in the risk of cold runs. In foundries



producing very long series and hence only using a few layouts the cost of replacing the gating systems is a lot less than the savings achieved.

In the cases where the pouring temperature is lowered it is also possible to reduce the size of the feeders accordingly. In this regard it is important to remember the results regarding the temperatures in the feeders found in the chapter 'Simulations'. The results here showed that the temperature in the warm feeders in the traditional layout is only 40°C higher than the temperature in the cold feeders in the streamlined layout. This small temperature difference shows that the advantage of having a warm feeder instead of a cold feeder is minimized.

### 12.4 Filtration

In the chapter regarding filtration it was recommended to remove the unwanted particles in the melt before pouring the melt into the mould. The reason for this recommendation was the fact that the experiments proved that the use of filters do not improve the flow pattern during mould filling the way it is often claimed to do. Actually the use of filters did the exact opposite. When using sand moulds, it may be argued that some of the unwanted inclusions is due to sand particles from the mould itself and therefore it is necessary to have the filter in the mould to stop these particles.

The sand particles the filter is supposed to stop result from erosion of the mould during the filling of the gating system. However when positioning the filter in the mould the filter is squeezed lightly into the filter print to make sure that the filter stays in position during the mould filling. The result of squeezing the filter into the correct position is that sand particles are scraped off. These loose particles will be carried with the melt and end up in the casting. So even though the filter may prevent some sand particles from entering the casting the positioning of the filter also loosen new sand particles and the result will be the same. In this way the benefit of the use of a filter can be seen as a balance between the number of sand particles stopped and the number loosened.

A different approach to avoid sand inclusions is to avoid or at least to minimize the amount of loose sand particle in the first place. The first parameter in the minimization of sand inclusions is to have the correct quality of the moulding sand. In a greensand mould for example it is important to have the correct composition of the sand. If the composition of the sand is wrong, sand grains have a higher tendency to loosen. The second parameter is to avoid erosion in the gating system during mould filling. Not much work has been done to investigate the consequences in this mechanism. It is believed however, that the main problem regarding erosion in the gating system occurs when a jet of melt having high momentum splash at a given angle into a surface. Using streamlined gating systems and maintaining the runners full at all times reduce the risk of this occurring. At the same time it means that the traditional gating system is more prone to develop erosion than the streamlined gating system.

### 12.4.1 Misinterpretation of surface defects

Often in foundries when evaluating the effectiveness of a filter it is done on the basis of the appearance of the surface of the as-cast gating system. If the surface is full of small recesses the conclusion is that these are due to slag and dross that has floated to the top before solidification and has fallen out during shake out, leaving these small recesses. An example of such surface defects is seen in Figure 12-2. The surface defect can be much more severe than what is seen here.

One of the major reasons for this conclusion is that these kinds of surface-defects most often occur in the so called slag-traps or in the filter print just before the filter. In this way it is shown that these arrangements are doing a very important job. A conclusion like this relies more on one wish to make this conclusion than on the actual process forming these recesses.

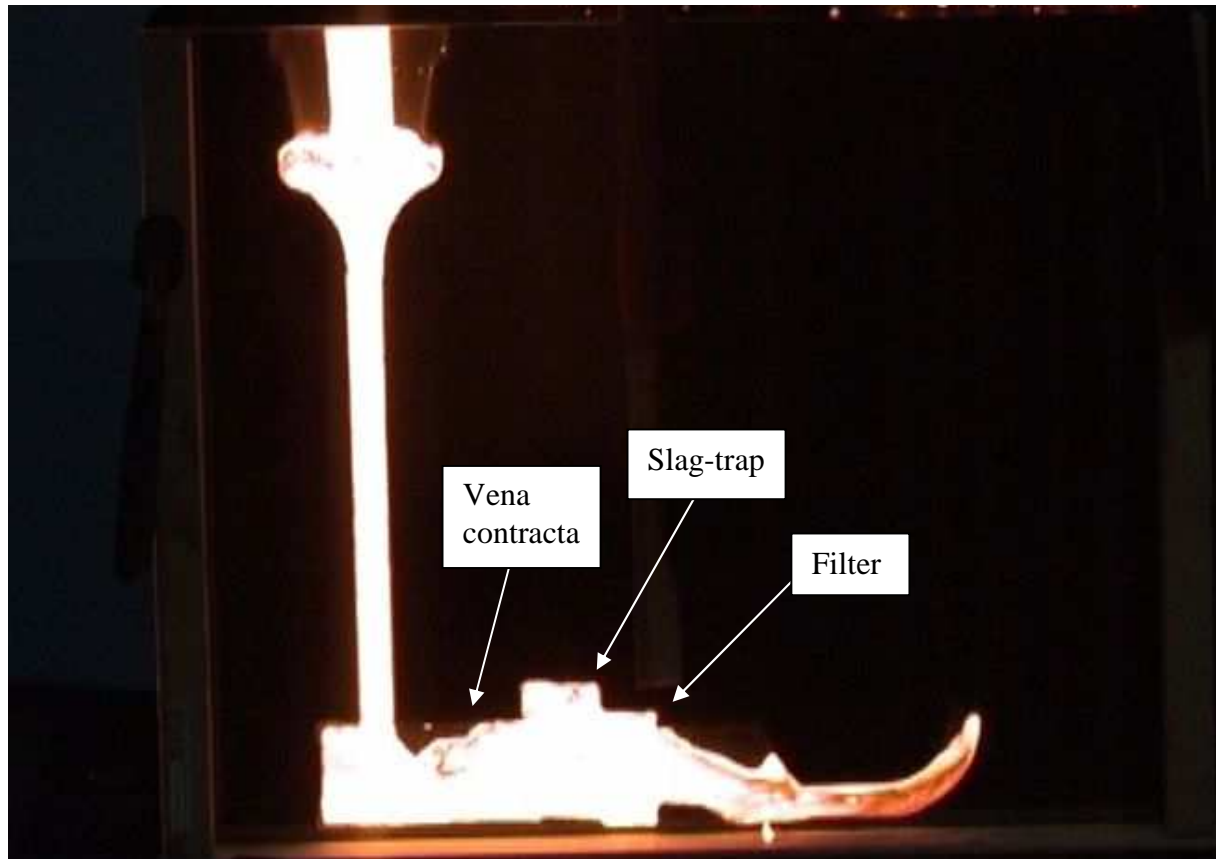
In the experiments using glass plate fronted moulds it is seen that the areas where these surface defects are found, are the exact same as those where pressure-shocks are formed when the last part of the gating system is backfilled. This means that these

surface defects occur where a vena contracta was formed during mould filling, or simpler in the parts of the layout where the gas trapped could not escape at the same rate as the backfilling happened.



**Figure 12-2**

In all of the experiments presented in the chapter ‘Filtration’ it was found that the pressure shock is formed when the gating system is backfilled all the way to the filter. An example is seen in Figure 12-3.



**Figure 12-3** The picture is an example from the chapter 'Filtration', Horizontal at time 0,52s.

In Figure 12-3 it is seen that neither the slag trap nor the filter print, is filled. However, the down runner is completely filled so at the time the gating system backfills there is nowhere for the gas to escape to trapped in these air-pockets. The backfilling happens so fast that the gas cannot flow through the mould since there is no venting in these areas the way there is in the top of the mould for the castings. This means that it is the gas that forms the often observed recesses in the surface and not slag.

It could also be argued that if it were slag that formed these recesses in the surface, then how is it possible for particles to fall out so easily in the shake out. During the filling the particles are completely enclosed by the melt but when the particles supposedly float to the top of the runner all of the particles are free to simply fall from the recesses. This in it self sound very unlikely even if differences in surface energy and wetting is taken into account. Any shape of an inclusion that float to the top, but due to

the mould not on the top of the melt, will still be somewhat enclosed and hence will not be able to simply fall out of the recess.

### **12.5 Ways of investigating flow patterns**

In general when comparing the experimental results from the x-ray experiments and the results from the experiments using glass plate fronted moulds using the same layout there are only minor differences. A large benefit from the x-ray experiments is the complexity of the geometry which can be examined. In the experiments using glass plate fronted moulds only the flow in the parting line can be examined. This also means that it is often difficult to examine the flow if for example not all of the gating system is placed on the one pattern plate. This is not a problem using the x-ray equipment. A further benefit in the x-ray experiments is that there is no glass that brakes due to thermal shock. In the experiments using the glass plate fronted moulds there is always a concern about when the glass brakes. When that happens there is a risk that the mould is emptied again.

A benefit of using the glass plate fronted moulds is that there are only a few limits to the size of the area that can be examined. In the x-ray experiments there is a limit to how big an area that can be seen. The limit is due to the angle of view of the x-ray tube and the size of the x-ray chamber. Another limitation in the x-ray experiments is the amount of metal which can be poured. The limitation is set by the size of crucible the automatic pouring device can handle. Using glass plate fronted moulds there is no such limitation but then there may be a limitation in the weight of metal that the glass plates can support. This problem can be helped by adding an additional glass plate which is normally done for larger moulds or when a large distance between the clamps is necessary. When examining the flow of molten iron glass plate experiments also give an idea of temperature differences which x-ray experiments do not.

One down side using the x-ray equipment is the cost of maintenance. The cost of glass plate experiments is relatively very low. The conclusion and recommendation on

which type of experiment to conduct are therefore that one have to consider all of the above mentioned up- and downsides. In short these considerations regard the complexity of the geometries, or if the gating system crosses the parting line using x-ray is to prefer. For less complicated geometries glass plate experiments can give equally as good information about the flow of metal. It is important to state that the two ways of investigating flow patterns are supplementing each other well.

### 12.5.1 Using the results from these experiments

The results from either type of experiments are being used for achieving better mathematical models and descriptions of how molten metals flow leading to even more reliable computer simulations.

The experimental results should also be applied to help the users of simulation software to achieve a better understanding of how metals flow. Through this knowledge the user will gain a better basis for interpretation and understanding of the simulation results. The necessity of such an understanding was seen in the simulations of the mould filling of the layout for the chapter 'Runner width'. Having knowledge of approximately how the flow pattern should look like helped to see that the results from the simulations were incorrect.

In the simulations for the layout in the chapter 'Runner width' it was found that the incorrect results are due to the fact that surface tension is not taken into account in the numerical models. This is theoretically possible to do, but for practical reasons this is not done because it will give unreasonably long calculation times. This is not always the reason for achieving unlikely results from simulations. To day Incorrect results from computer simulations are most often due to boundary conditions incorrectly set. Having an idea of the correct flow pattern can help the user to find out which parameter should be changed for more reliable simulation results.

## 12.6 Considerations regarding design

In this project it has been shown that there are more ways of saving energy, material, and production time when producing a certain part. It has been proven that a streamlined gating system improves yield compared to the traditional gating system. It has also been proved that the use of fan gates in the gating system can improve the heat distribution in the casting giving more uniform material properties and decrease the need for heat treatment. At the same time it is commonly known that a correct design of feeders has a huge influence on yield. Further savings can be done if already in the design phase considerations are made regarding how to ease the casting of the part.

In this project it was proven that large savings were achieved throughout the entire production line after the valve housing was re-designed considering the feeding during solidification. Together with a redesign of the gating system and the feeders this finally led to a much cheaper product with a shorter overall production time. This illustrates how important it is that early in the design phase of the product designers are in dialog with production people.

## References

**[Ref. 12-1] Xu, Z.A., Mampaey, F. – Computer Simulations of Mould Filling for Horizontal Castings and Its Experimental Validation, European Journal of Mechanical Engineering, Vol. 40, 1995**

**[Ref. 12-2] Campbell, J. – Castings Practice The 10 rules of casting. Elsevier Butterworth-Heinemann, 2004**





## 13 Conclusions

The main purpose of the project has been to investigate the possibilities for reducing the energy consumptions in foundries by reducing the amount of metal to be re-melted by using streamlined gating systems instead of the traditional gating systems.

A gating system for a valve-housing was designed using the principles for streamlined gating systems and the result was investigated and compared to the result of a traditional gating system. It was proven that the weight of the gating system excluding feeders was reduced from 5,6kg to 4,5kg. This reduction in poured weight of the gating system of 1,1kg indicates the amount of the reductions in poured weight that can be expected in other similar examples. One part of the weight reduction is due to the difference in the placement of the ceramic filter from the traditional layout to the streamlined layout but the major part is due to the weight reduction in the runner system it self. The experiments also proved possibilities of reducing the pouring temperature by 100°C and of avoiding the need of heat treating the castings. Experiments were also conducted for horizontal moulding using the principles of the streamlined gating systems for two valve housings. The results showed that the weight of the gating system was reduced by 3,7kg which is also 60% compared to the traditional layout.

The energy saved per mould in both the vertical and the horizontal layout is seen in Table 13-1. For both layouts only the weight reductions in the gating systems are used. The value for the heat treatment is based on all three valve housings in the layout being heat treated.

	Vertical layout	Horizontal layout
Energy saved for melting	1,31 kWh	25,16 kWh
Energy saved for heat treatment	4,40 kWh	
Energy saved in total	5,71 kWh	25,16 kWh

**Table 13-1 The Energy saved for the two layouts per mould**

When the moulds for the vertical layout is produced on a Disamatic that produces 350 moulds an hour the total energy saved per hour for both melting and heat treatment becomes 1999kWh and per eight hour work day 15988kWh. Seen in this perspective the potential for saving energy in the foundries is substantial.

It has been shown that re-designing a casting taking the casting process into consideration can improve the quality of the final product and at the same time lower the cost and production time.

The experiments casting the valve-housing raised a question of how the flow in the streamlined gating system would be affected if the maximum runner width of 10mm was increased. Experiments revealed that increasing the runner width to 14mm is possible in cast iron with only small tendencies of problems in maintaining the horizontal runner full. It is therefore likely that 14mm in runner width is the limit.

The use of ceramic filters has been investigated. A series of experiments using glass plate fronted moulds were conducted. For these experiments commercially recommended filters and filter-prints for correct placement of the filters were used. All of the results proved that the use of filters whether it is pressed- or foam filters do not improve the flow pattern as often claimed. Filters in all of the experiments divided the molten metal into a number of smaller streams or jets from the exit surface and hence did not provide the calm and coherent flow of metal as filters often are claimed to do. The experiments also proved that the large volumetric expansions of the gating system in the filter prints generates large pressure shocks when backfilled. These pressure shocks generate a highly turbulent flow pattern. The recommendation from the study of flow through filters is that filters should only be used for the purpose of filtration, and if possible the use of filters should be avoided. It was proven that the poured weight is easily reduced by 0,6kg by not using filters.

A series of experiments were conducted using the x-ray facilities at the Metallurgy and Materials department at the University of Birmingham. These experiments underlined the importance of pouring in such a way that the very top cross section is maintained full at all times. The experiments also proved how difficult this can be in practice. The flow pattern and the maximum velocity during mould filling were proven to depend heavily on this parameter. In addition the experiments proved that very thin fan gates have a high filtration capability. Finally, from the experiments using x-ray it was proven that results from experiments using glass-plate fronted moulds gives representative and reliable results.

A number of tools and standard geometries have been developed to ease the implementation and use of streamlined gating systems in foundries. These are already now being used by the foundries in the project and they are under implementation by foundries all over the world.

### **13.1 Recommendations for future work**

The results regarding filtration and the use of ceramic filters proved that filters should only be used for filtration and preferably not be used at all. Therefore new methods of cleaning the molten metal should be developed. An investigation of the existing methods for bulk filtration should be carried out and if necessary these methods should be improved. One way to filter the molten metal could be to place a filter right under the pouring device. By doing this the filter might also be reused and time is saved when producing moulds for coreless castings.

In the work presented here only cold feeders have been used. It is recommended that a thorough study of how to use the streamlined gating systems in combination with warm feeders is carried out.

One of the basic recommendations using streamlined gating systems is to use bottom-filling. However investigations should be done to find good methods in case the size of the casting and the size of the pattern plate do not leave room for this.

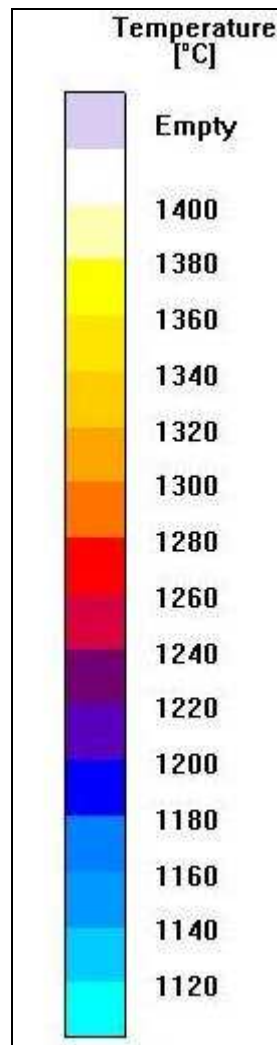
The majority of the experiments carried out so far using glass plate fronted moulds have been with ductile iron. To give good recommendations regarding different alloys and metals experiments are needed that describes the differences in flow patterns and surface tensions from one metal to another.

The use and design of fan gates for various more complicated geometries should be investigated. This should also be done to develop guidelines and recommendations for how to cast complex geometries with varying sections having differences in thicknesses and requirements of mechanical properties.

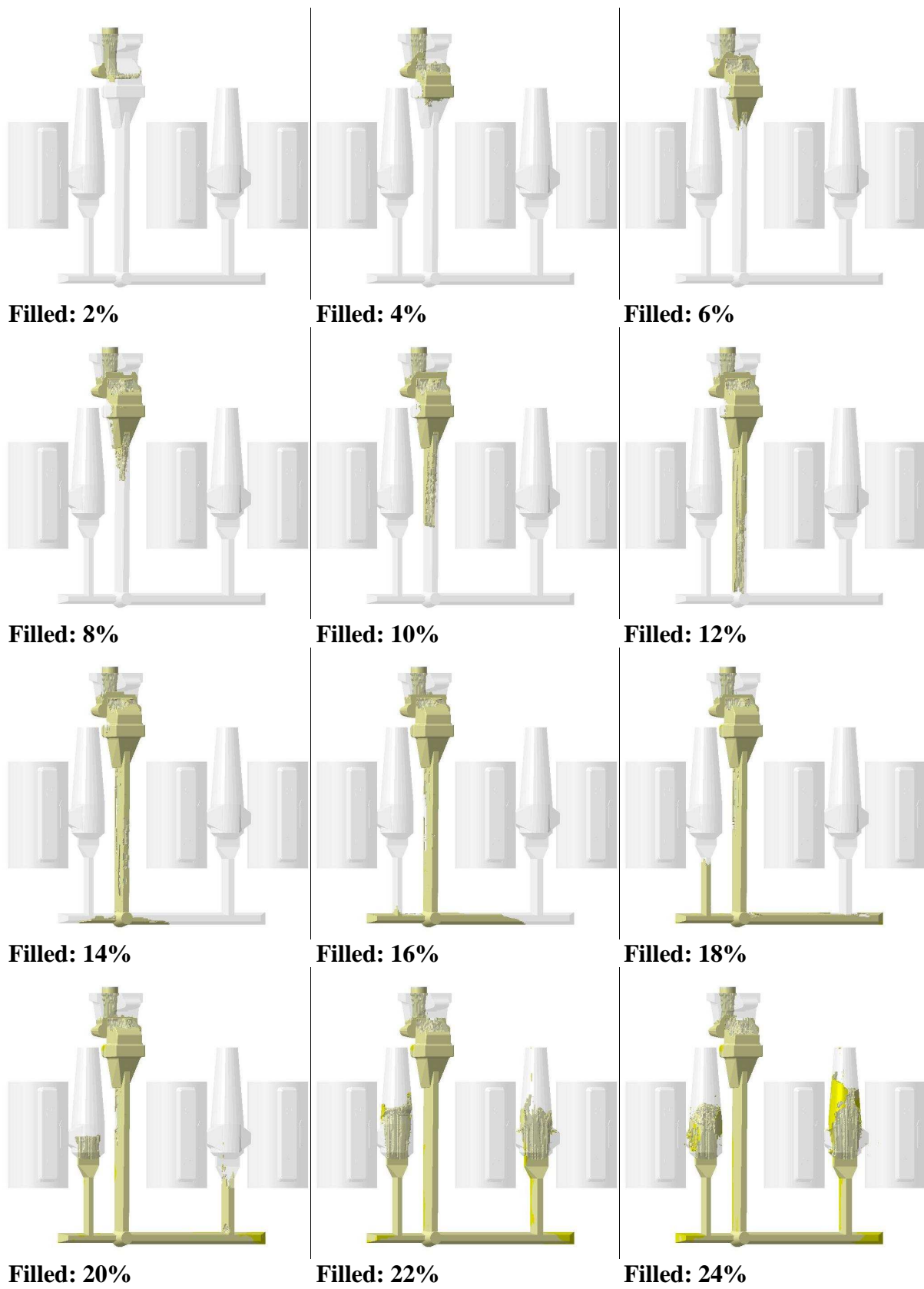
## 14 Appendices

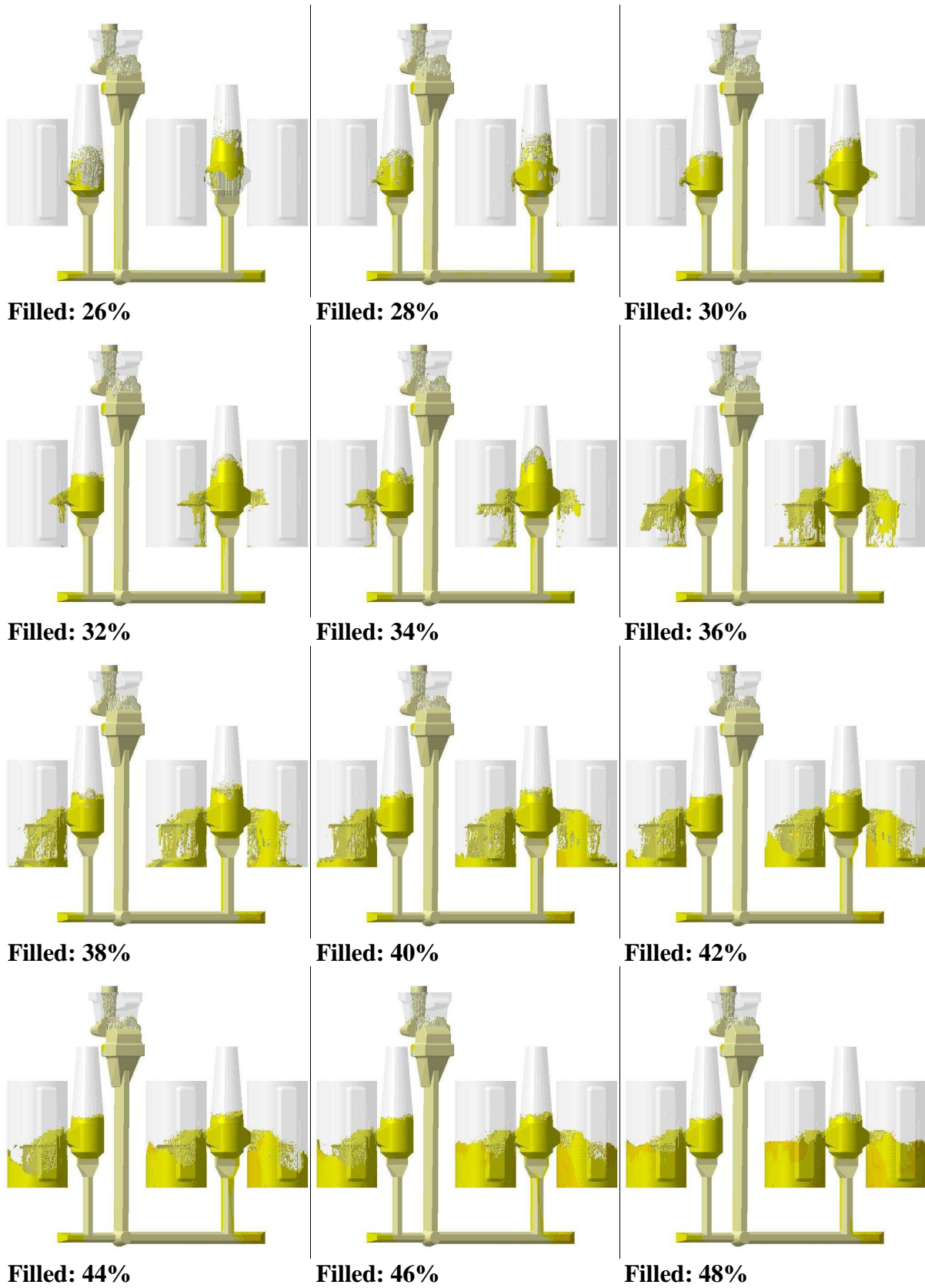
### 14.1 Appendix 1 – Simulation

#### 14.1.1 Temperature scale for the simulation results



### 14.1.2 The traditional gating system









**Filled: 50%**



**Filled: 52%**



**Filled: 54%**



**Filled: 56%**



**Filled: 58%**



**Filled: 60%**



**Filled: 62%**



**Filled: 64%**



**Filled: 66%**



**Filled: 68%**



**Filled: 70%**



**Filled: 72%**



**Filled: 74%**

**Filled: 76%**

**Filled: 78%**



**Filled: 80%**

**Filled: 82%**

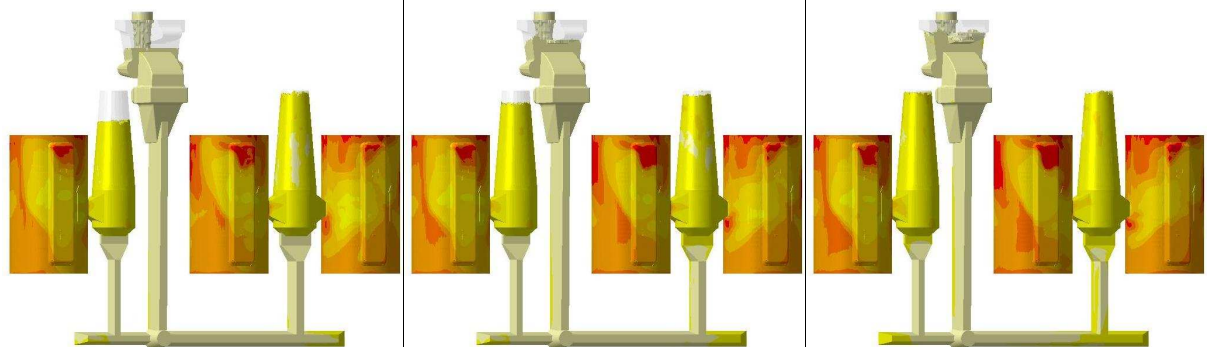
**Filled: 84%**



**Filled: 86%**

**Filled: 88%**

**Filled: 90%**

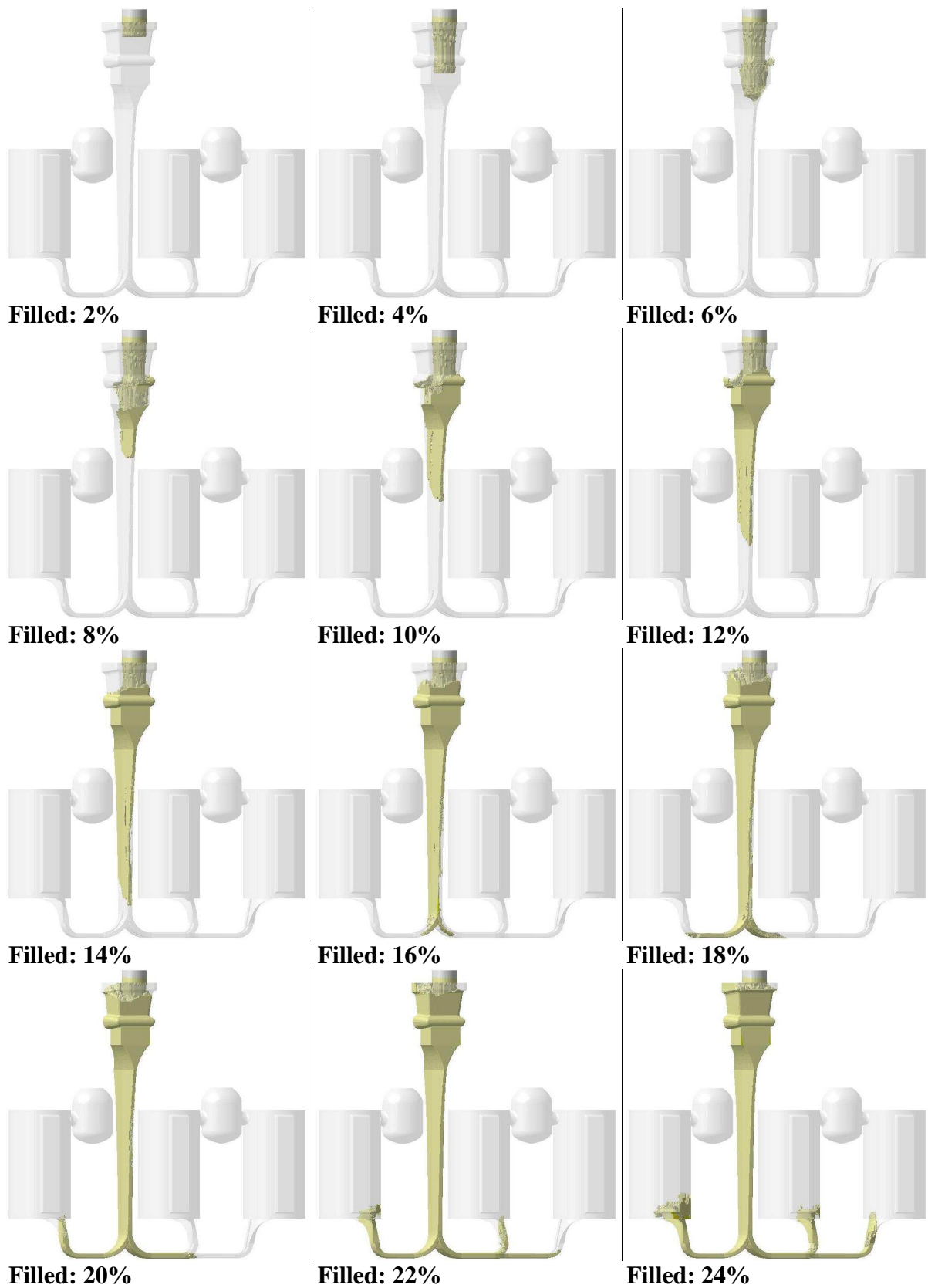


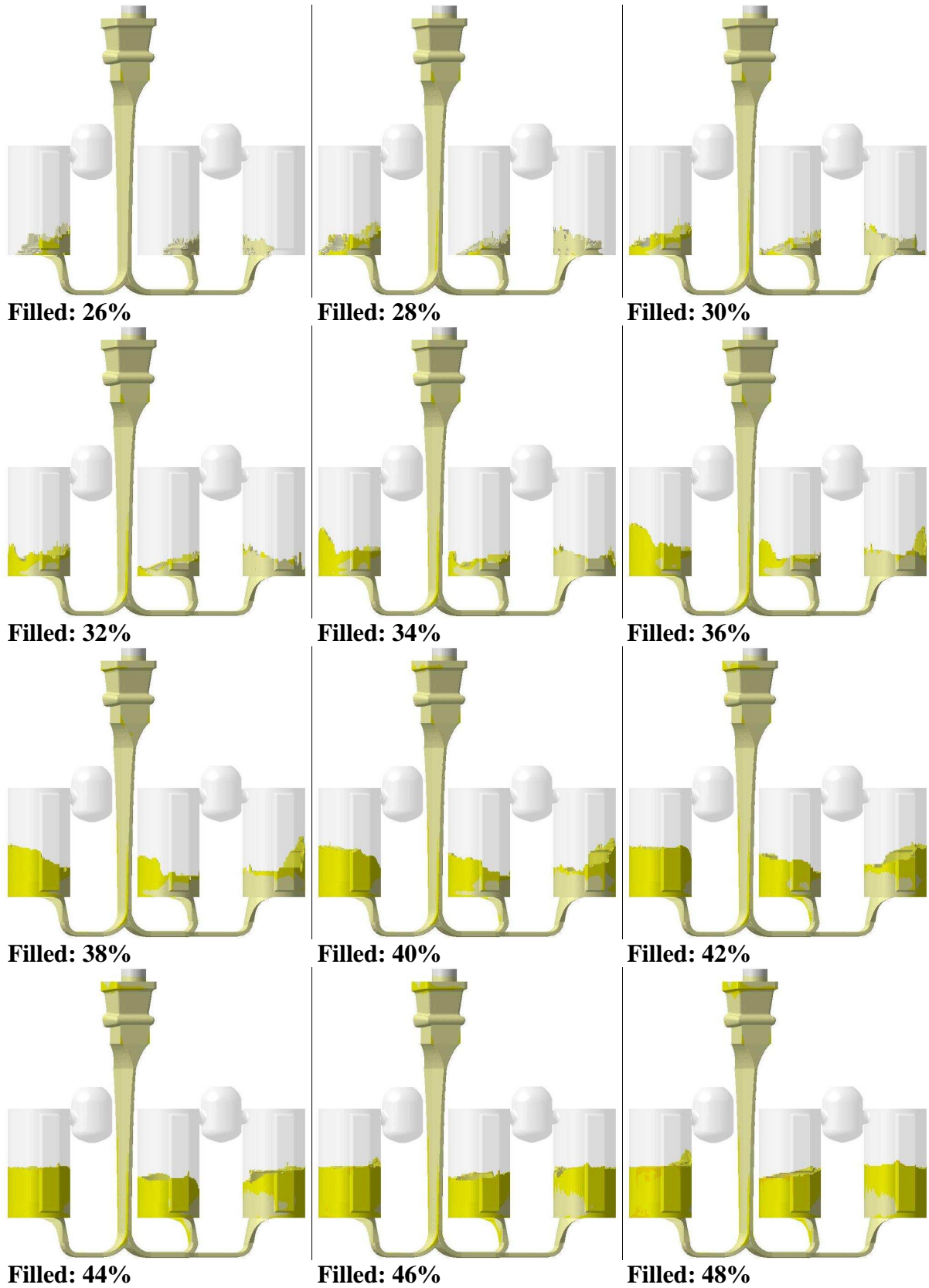
**Filled: 92%**

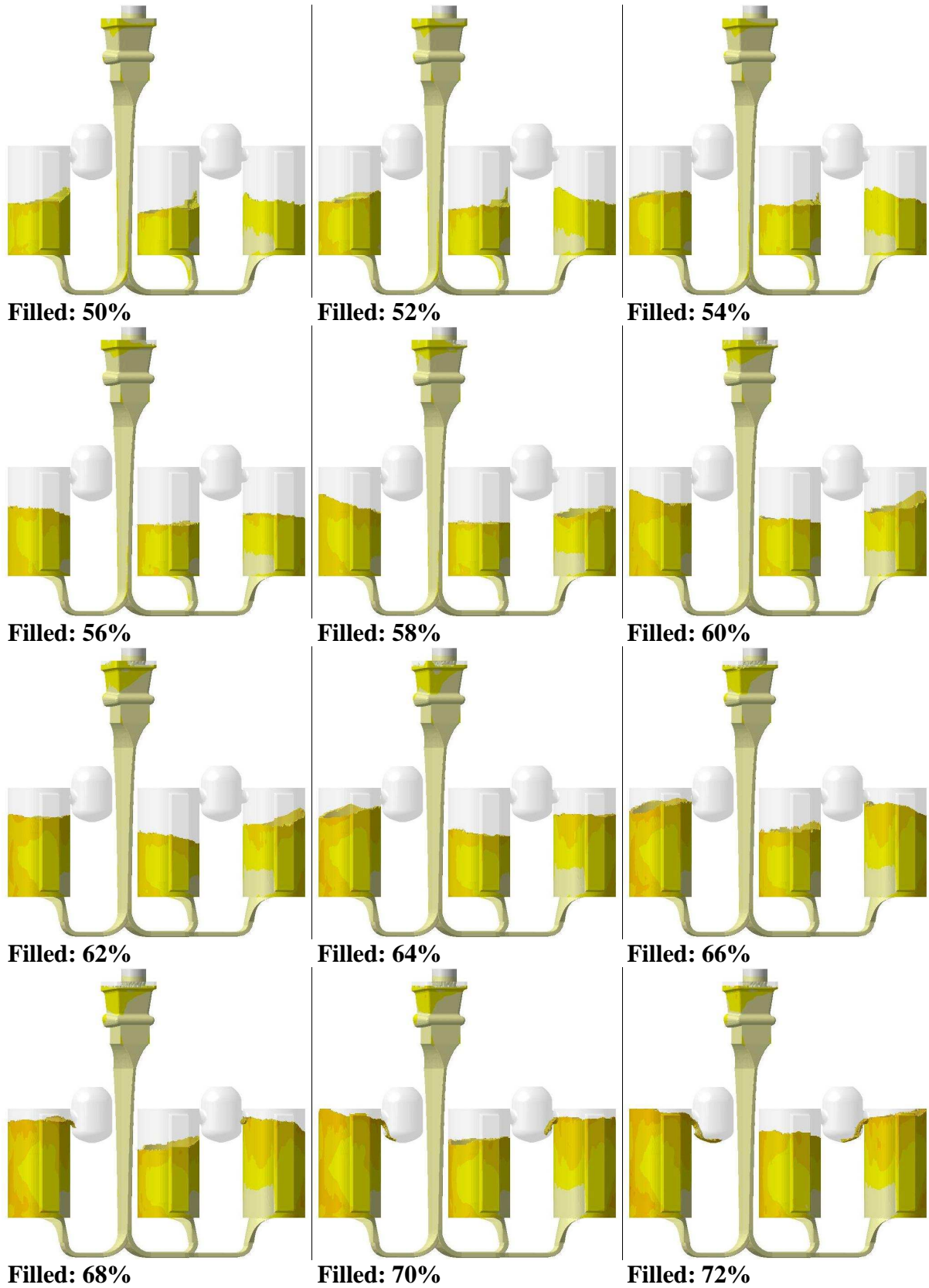
**Filled: 94%**

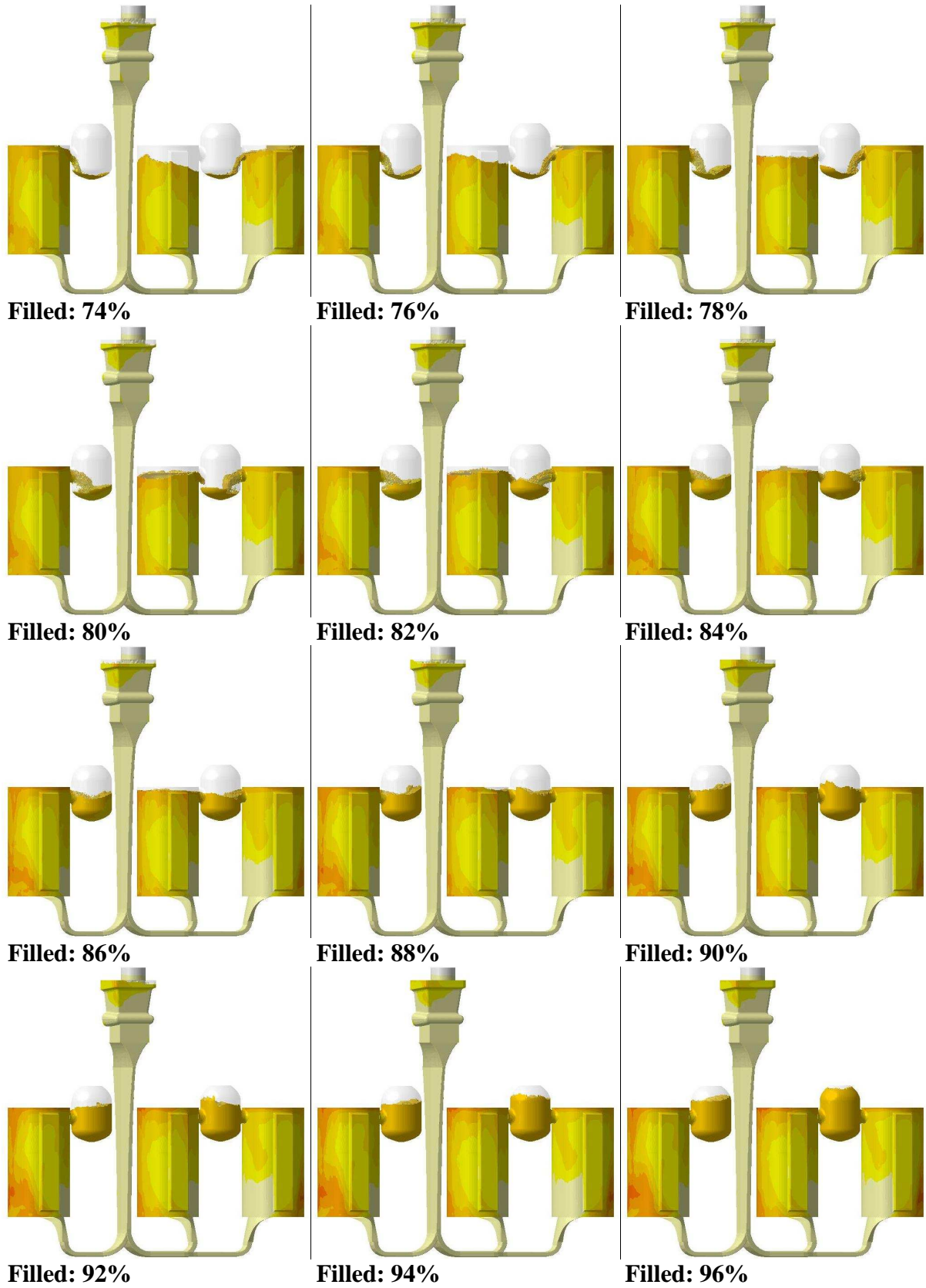
**Filled: 96%**

### 14.1.3 The streamlined gating system

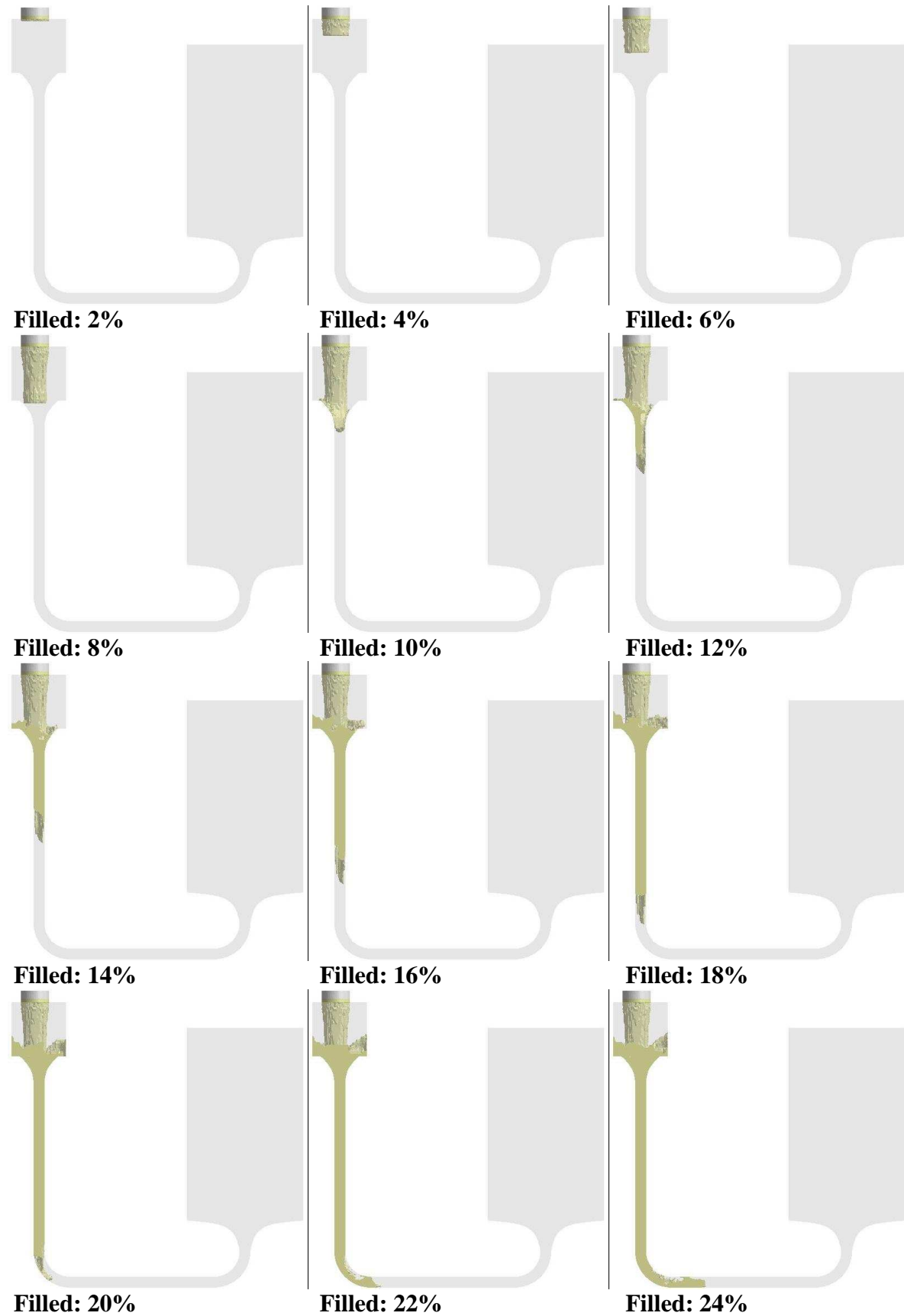


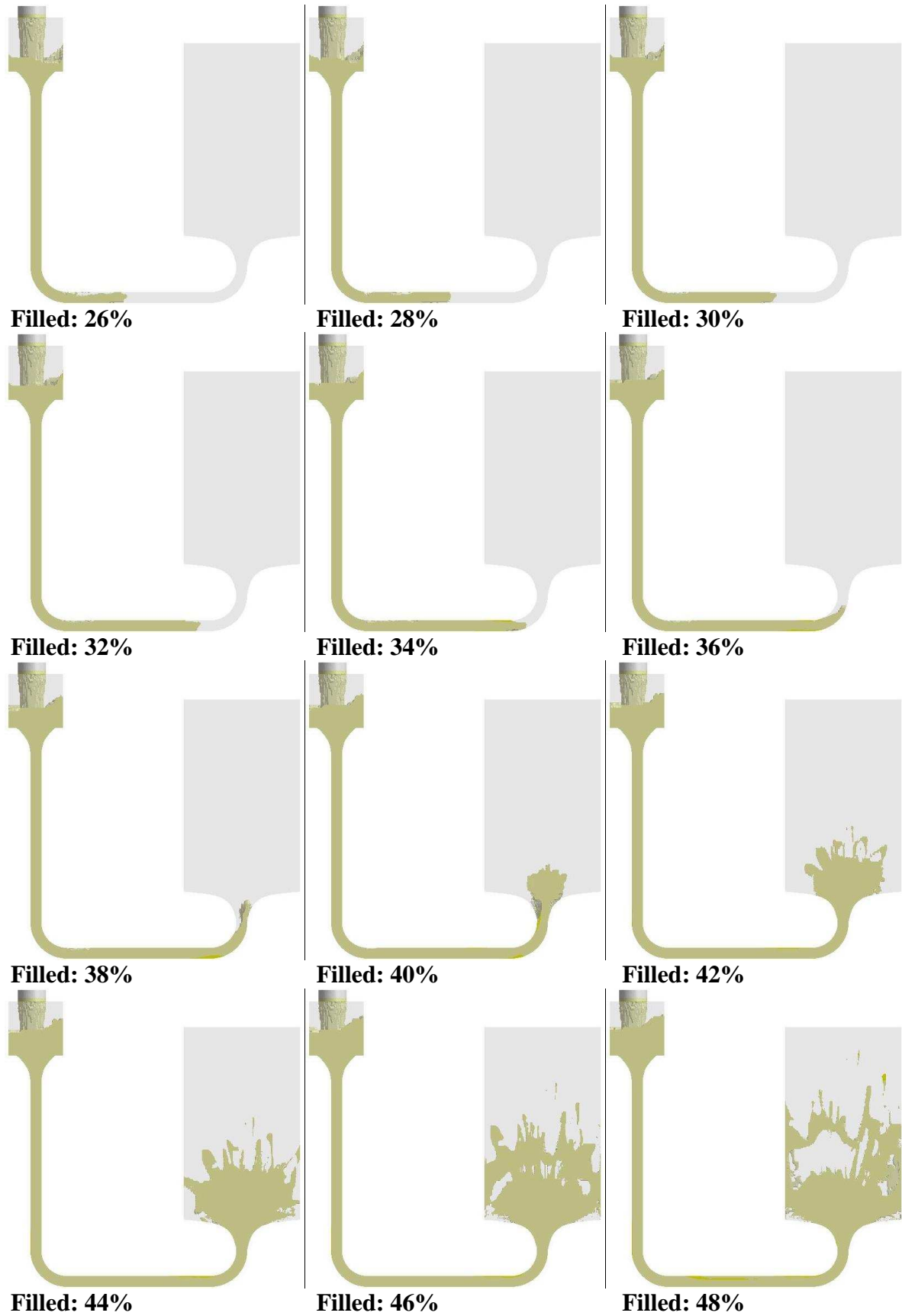




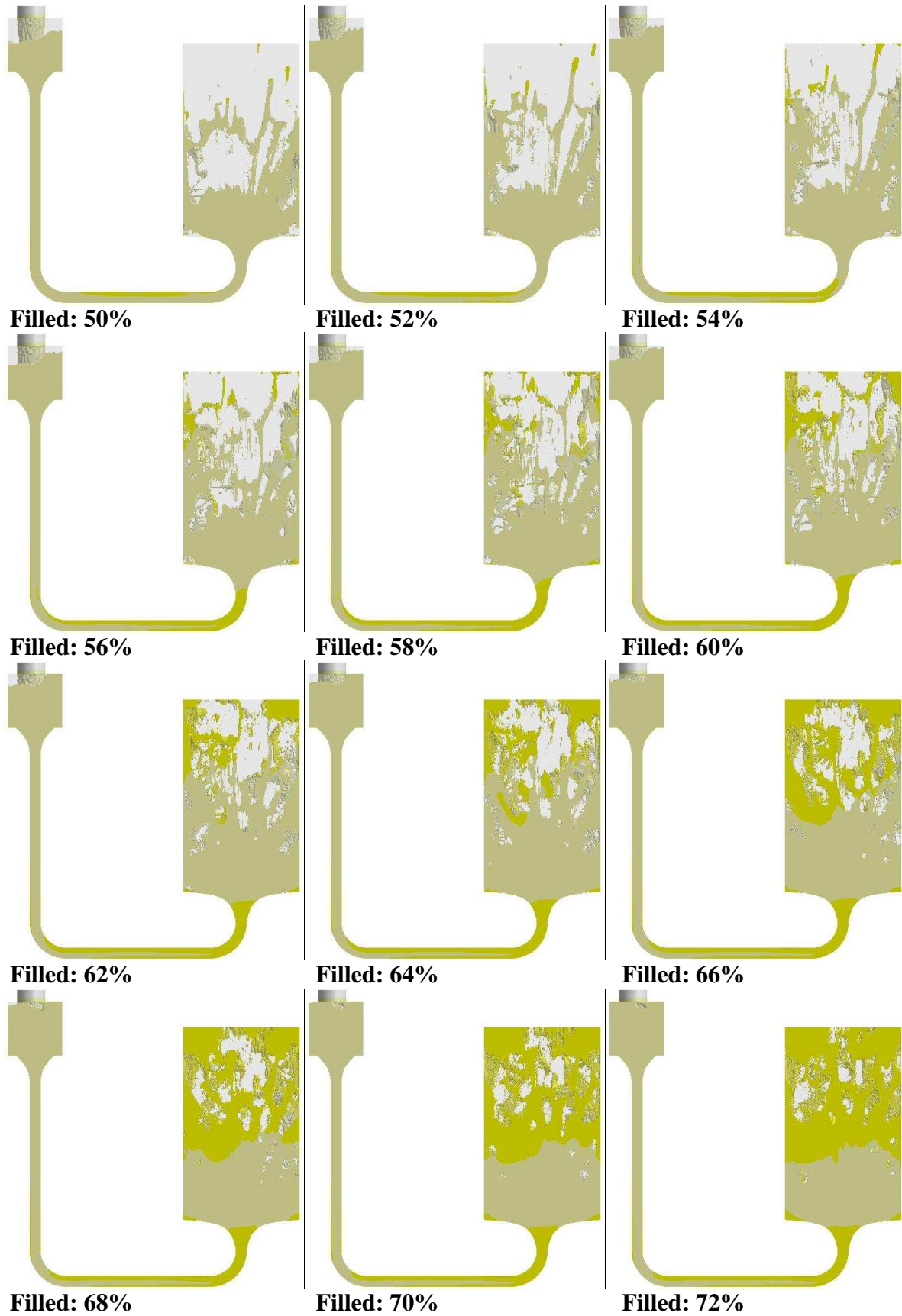


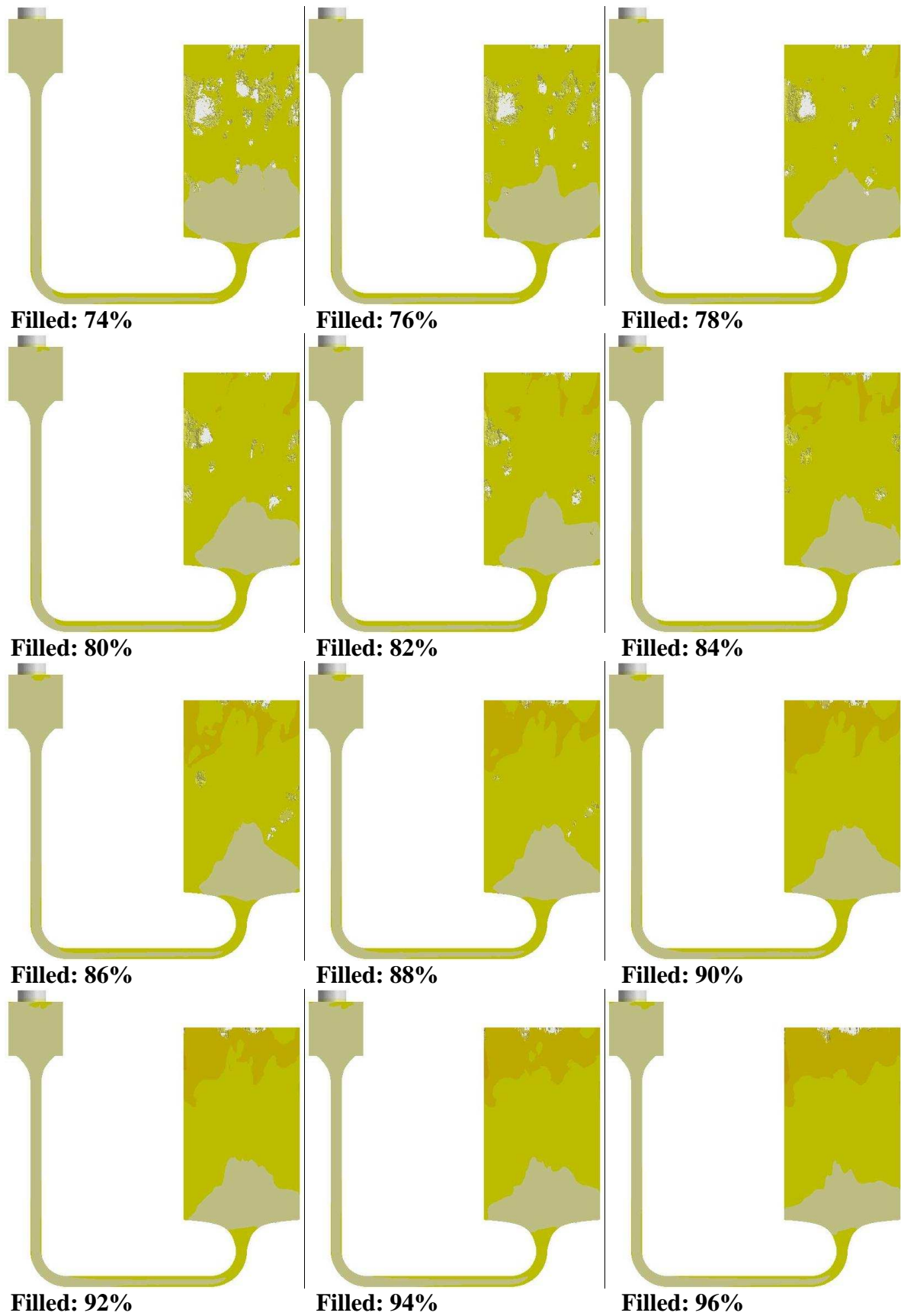
### 14.1.4 Runner width





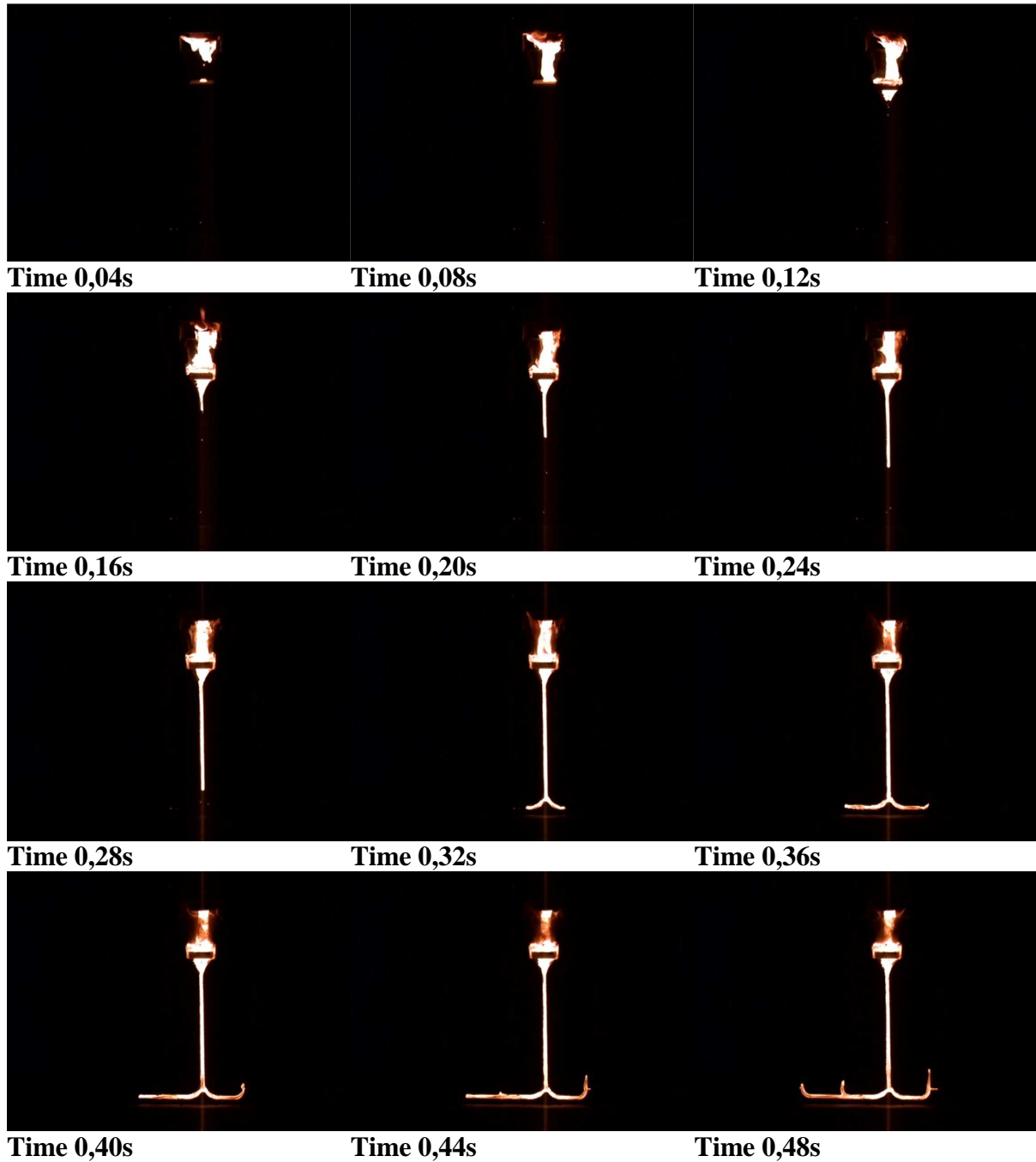


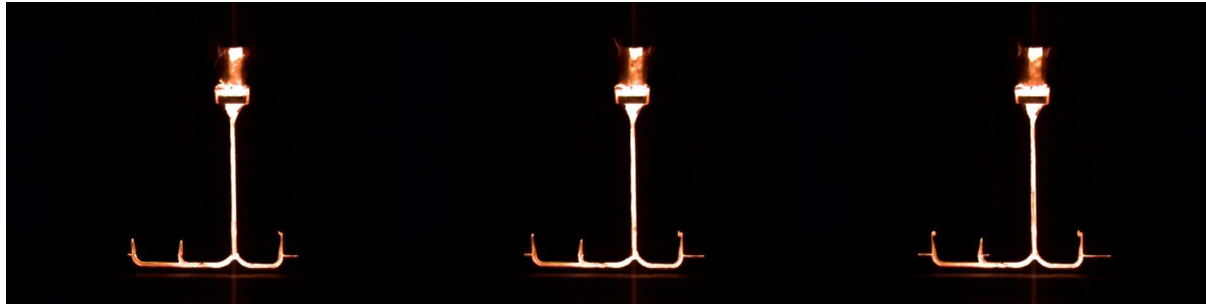




## 14.2 Appendix 2 - Casting of a valve housing

### 14.2.1 Streamlined gating system – Pressed filter

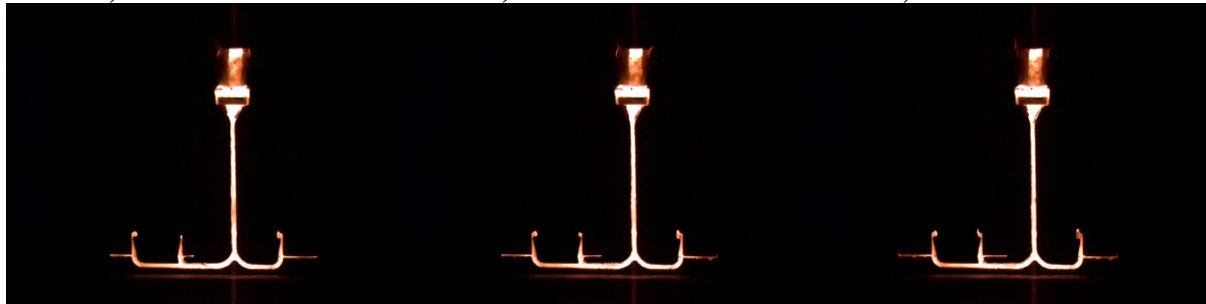




**Time 0,52s**

**Time 0,56s**

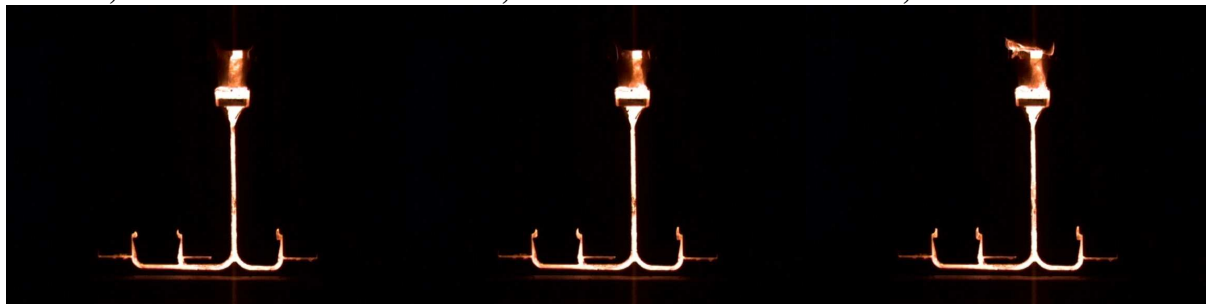
**Time 0,60s**



**Time 0,64s**

**Time 0,68s**

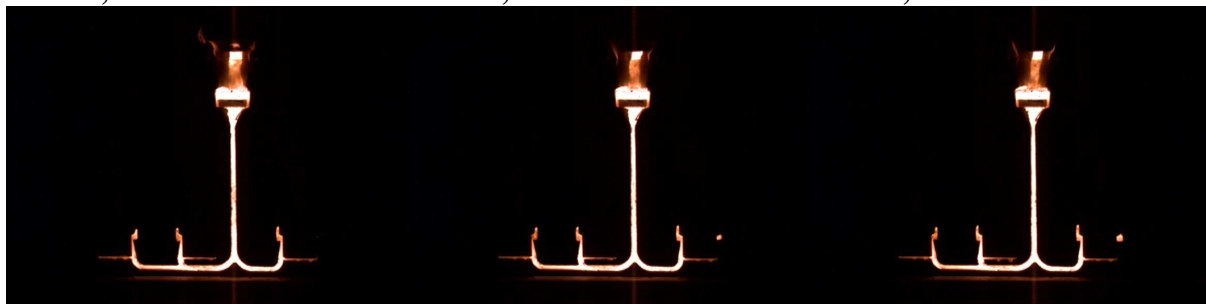
**Time 0,72s**



**Time 0,76s**

**Time 0,80s**

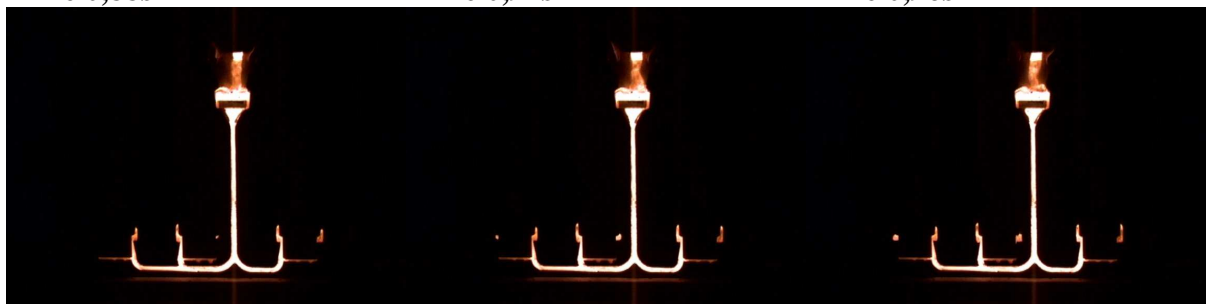
**Time 0,84s**



**Time 0,88s**

**Time 0,92s**

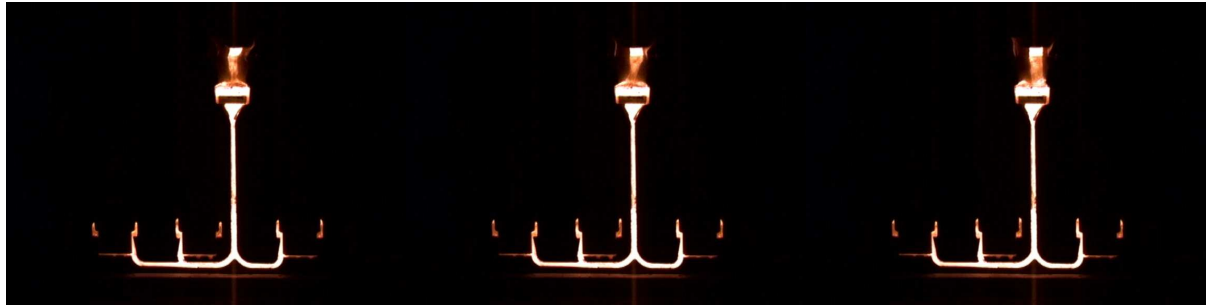
**Time 0,96s**



**Time 1,00s**

**Time 1,04s**

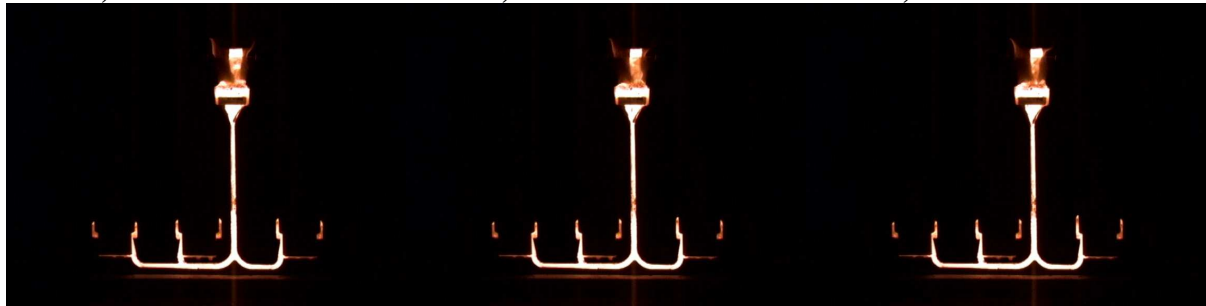
**Time 1,08s**



**Time 1,12s**

**Time 1,16s**

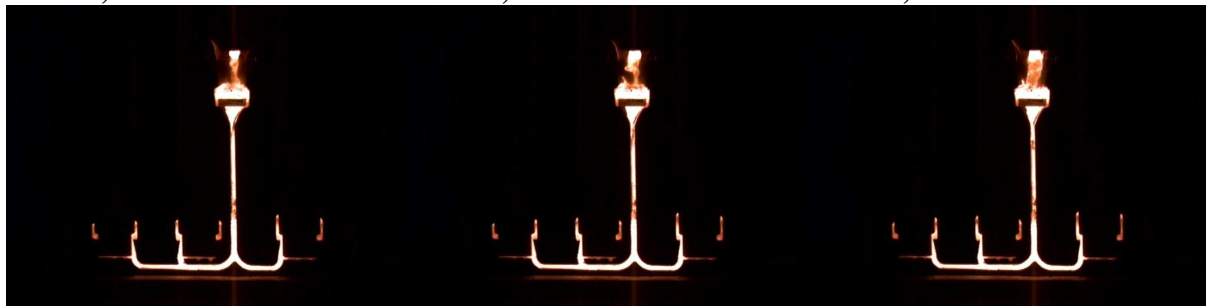
**Time 1,20s**



**Time 1,24s**

**Time 1,28s**

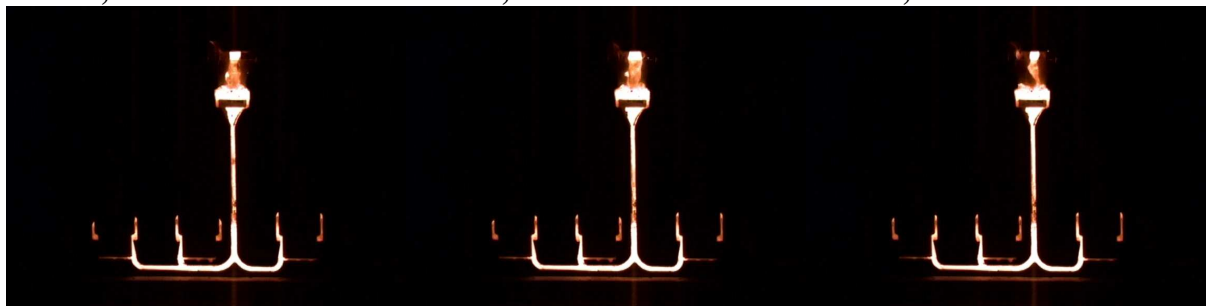
**Time 1,32s**



**Time 1,36s**

**Time 1,40s**

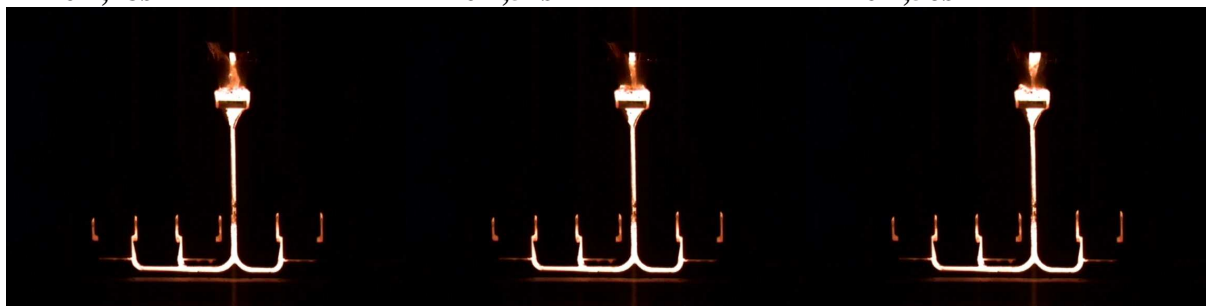
**Time 1,44s**



**Time 1,48s**

**Time 1,52s**

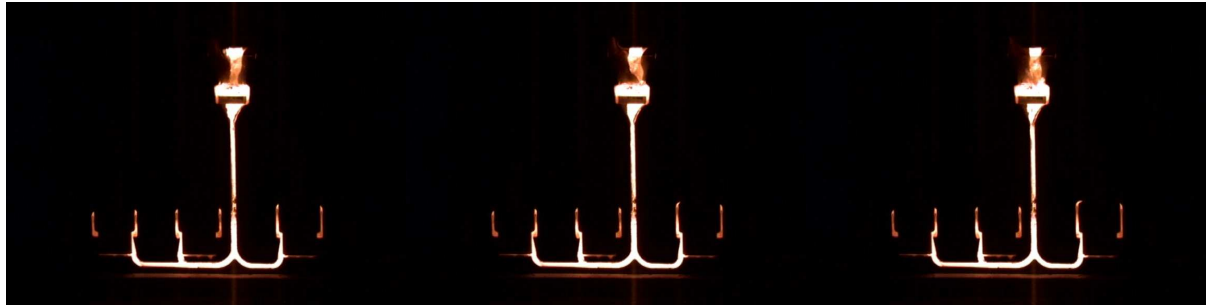
**Time 1,56s**



**Time 1,60s**

**Time 1,64s**

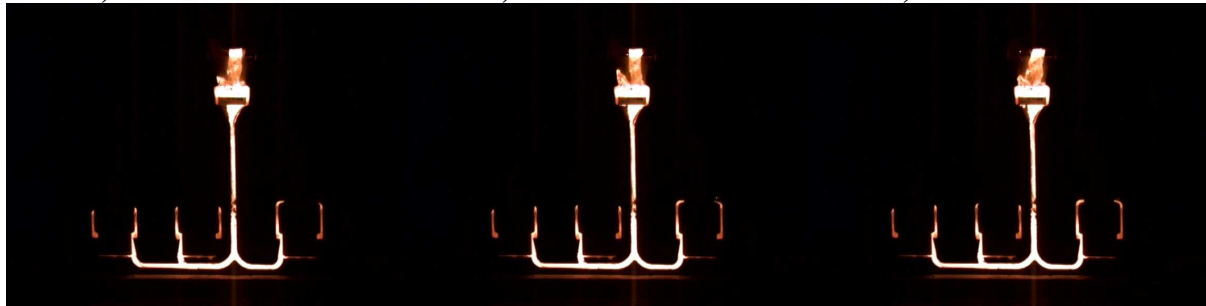
**Time 1,68s**



Time 1,72s

Time 1,76s

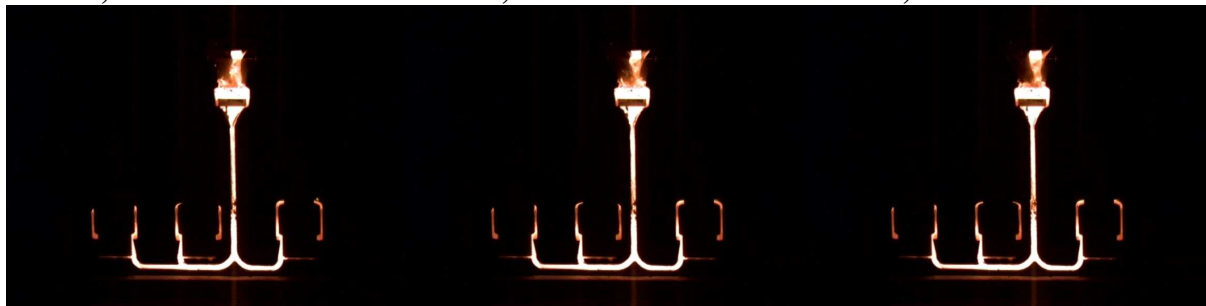
Time 1,80s



Time 1,84s

Time 1,88s

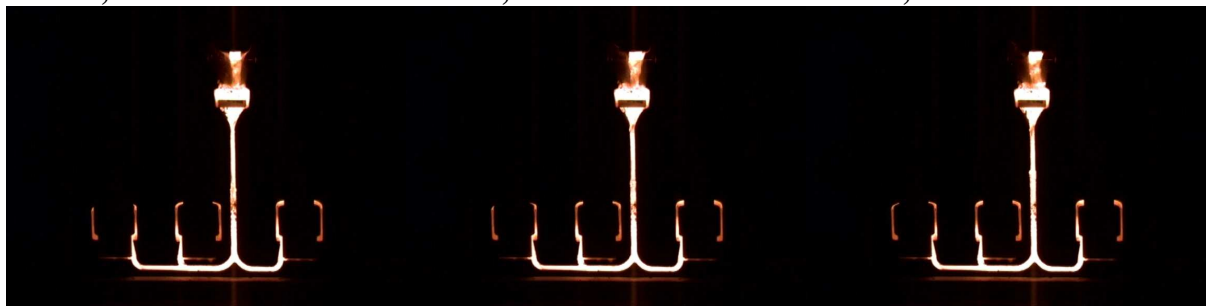
Time 1,92s



Time 1,96s

Time 2,00s

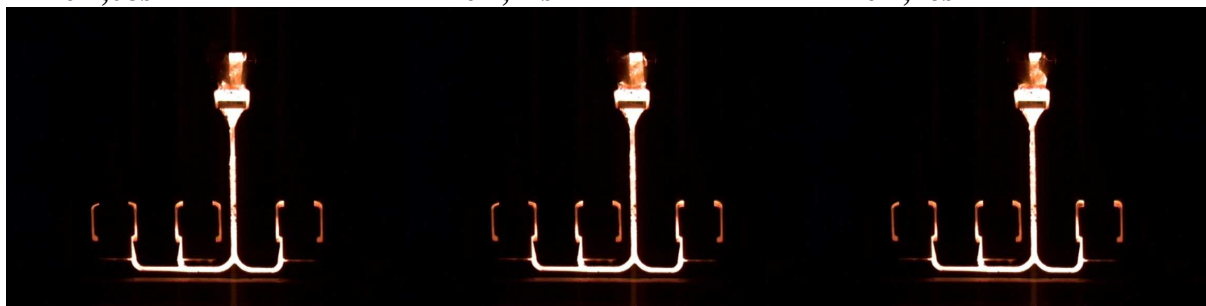
Time 2,04s



Time 2,08s

Time 2,12s

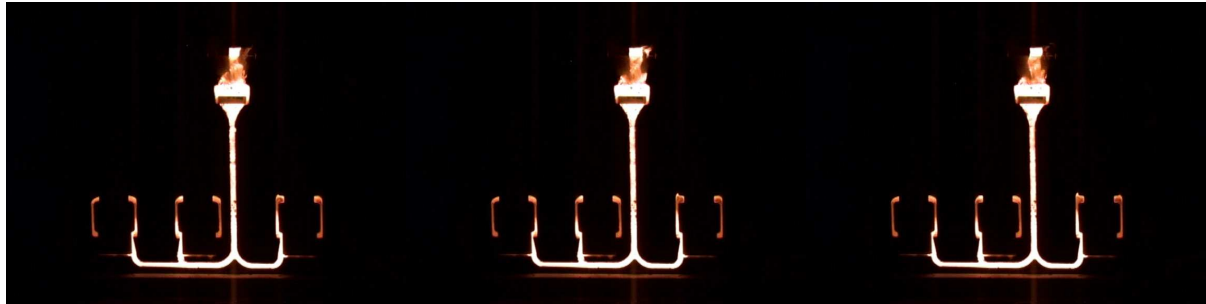
Time 2,16s



Time 2,20s

Time 2,24s

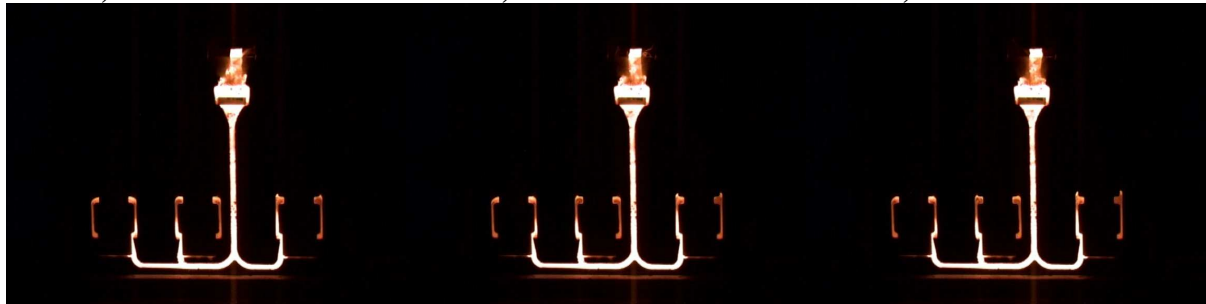
Time 2,28s



Time 2,32s

Time 2,36s

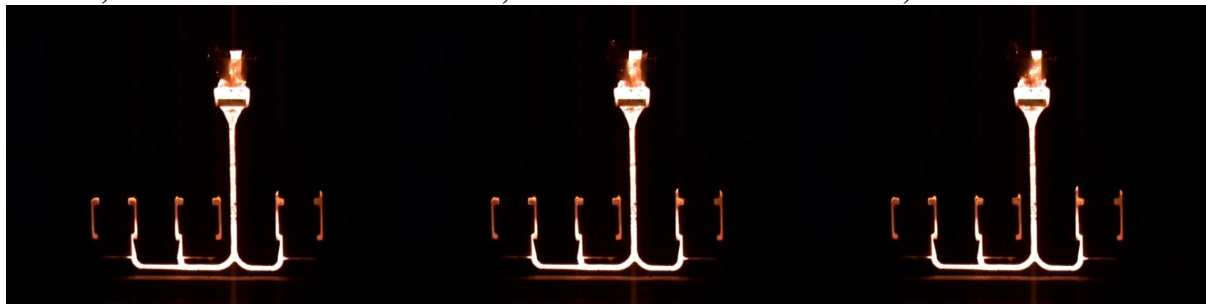
Time 2,40s



Time 2,44s

Time 2,48s

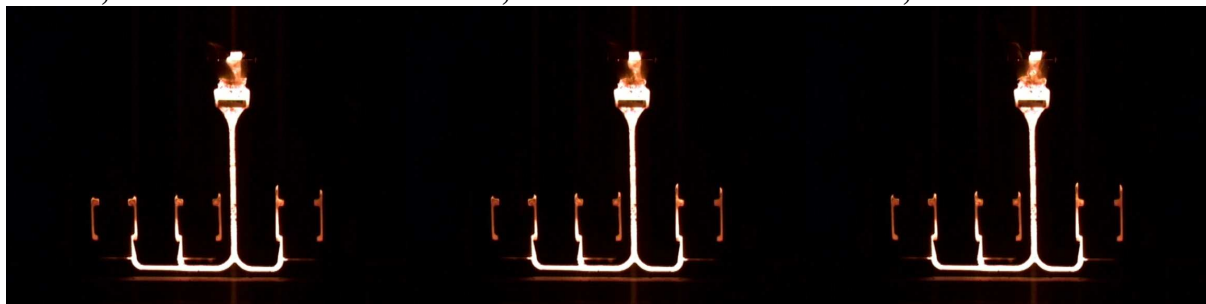
Time 2,52s



Time 2,56s

Time 2,60s

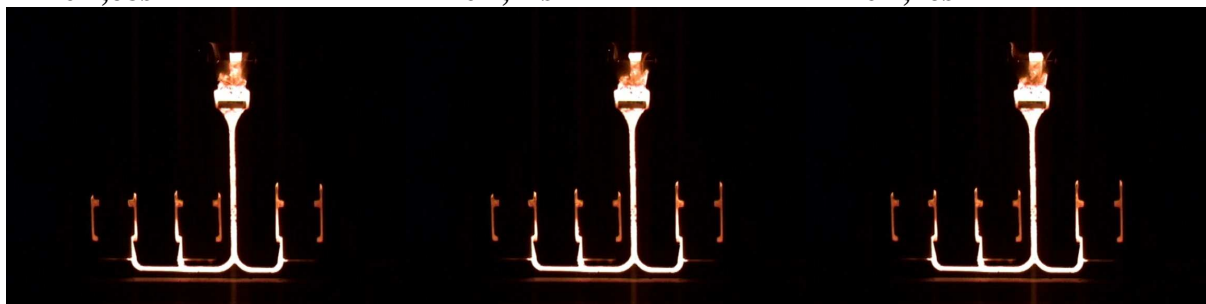
Time 2,64s



Time 2,68s

Time 2,72s

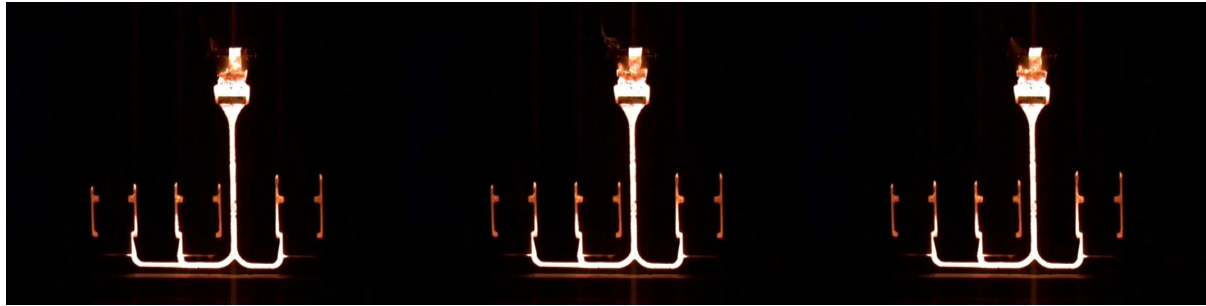
Time 2,76s



Time 2,80s

Time 2,84s

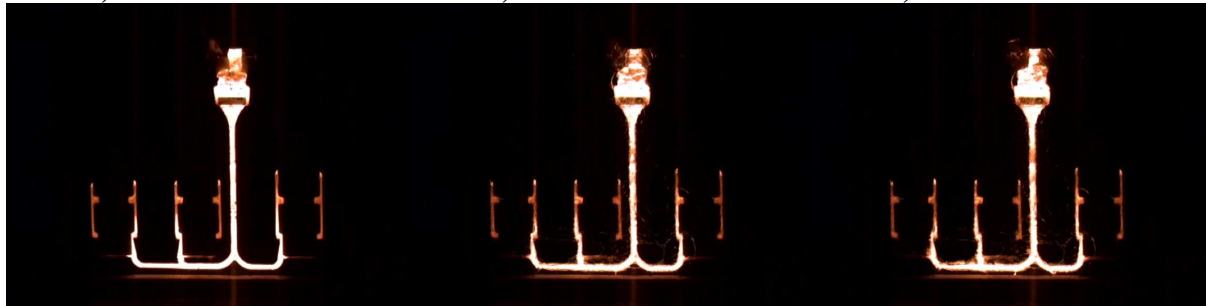
Time 2,88s



Time 2,92s

Time 2,96s

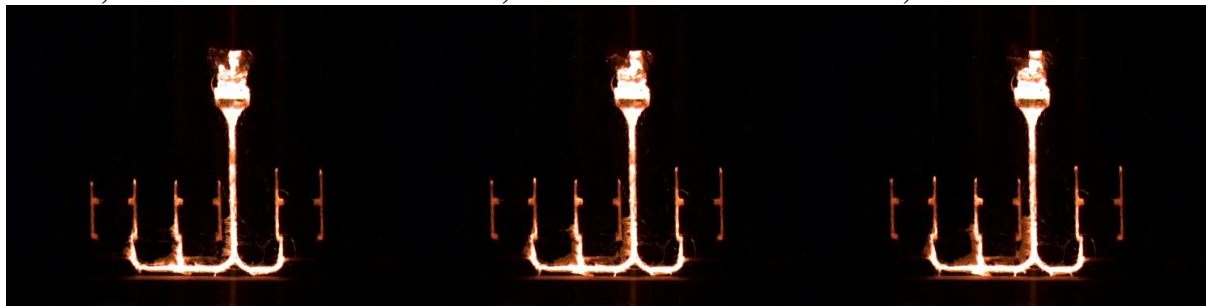
Time 3,00s



Time 3,04s

Time 3,08s

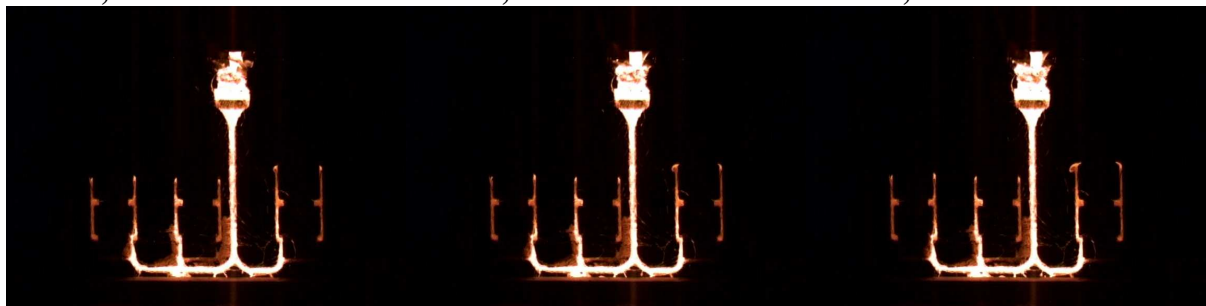
Time 3,12s



Time 3,16s

Time 3,20s

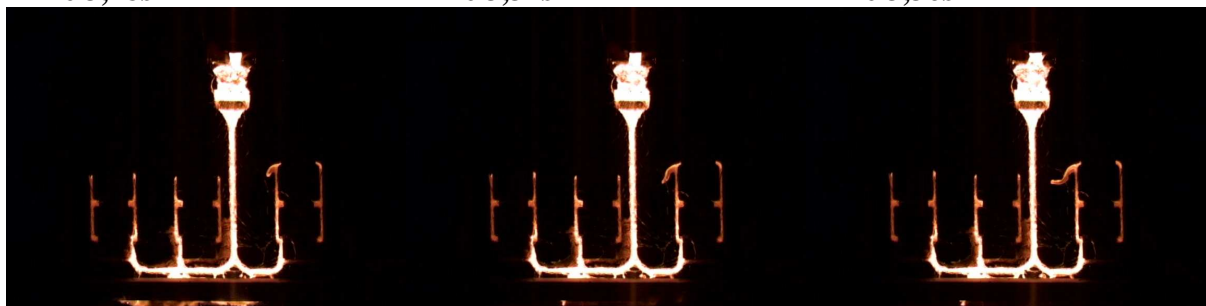
Time 3,24s



Time 3,28s

Time 3,32s

Time 3,36s

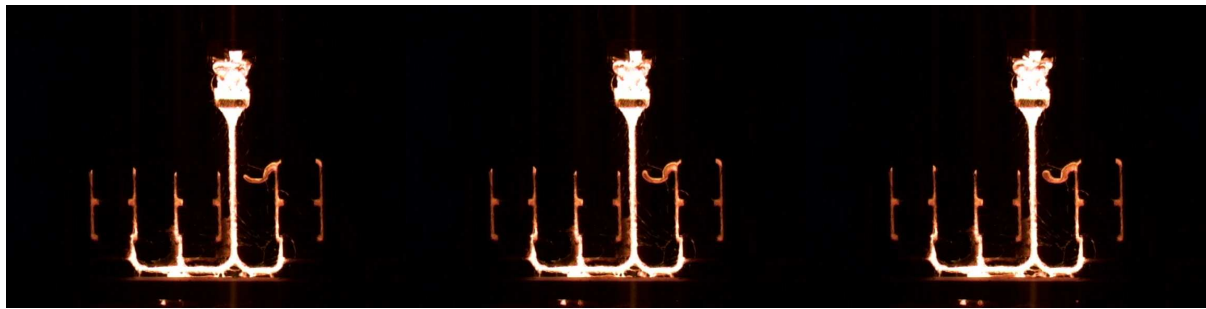


Time 3,40s

Time 3,44s

Time 3,48s

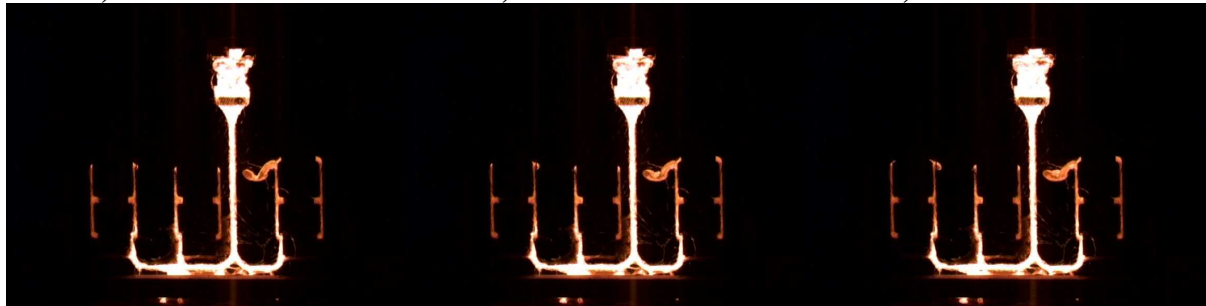




Time 3,52s

Time 3,56s

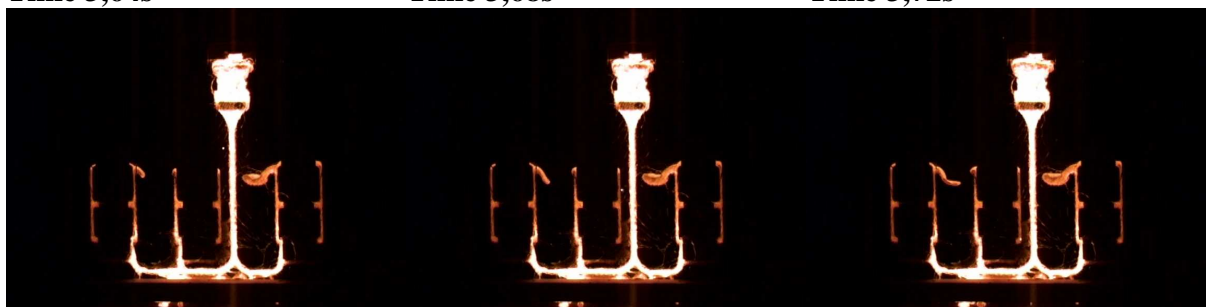
Time 3,60s



Time 3,64s

Time 3,68s

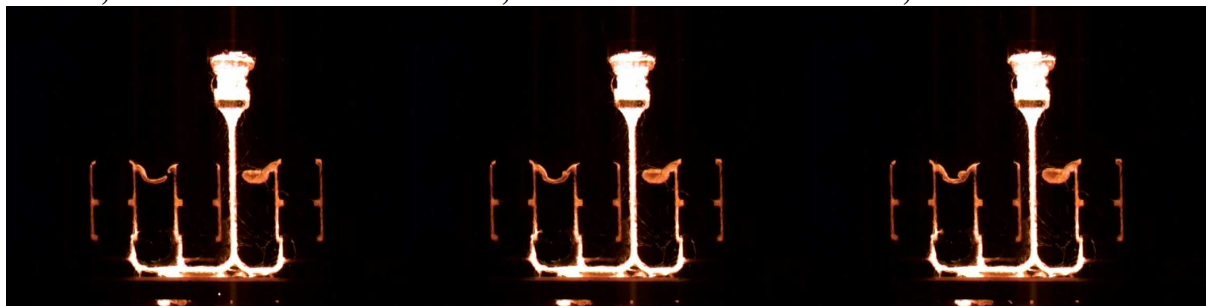
Time 3,72s



Time 3,76s

Time 3,80s

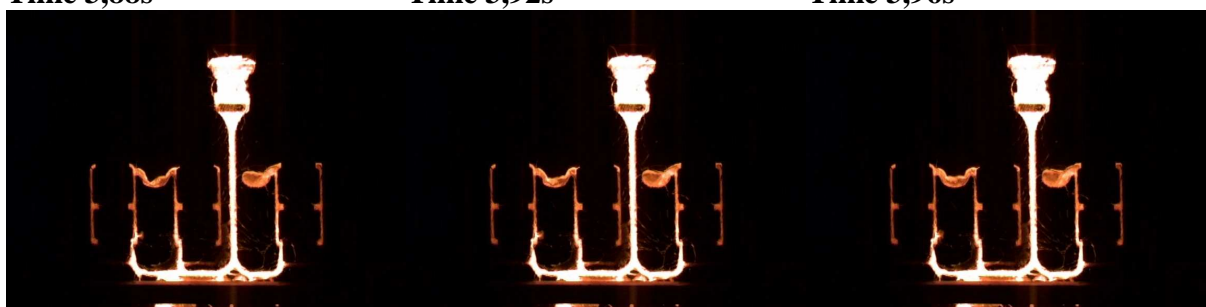
Time 3,84s



Time 3,88s

Time 3,92s

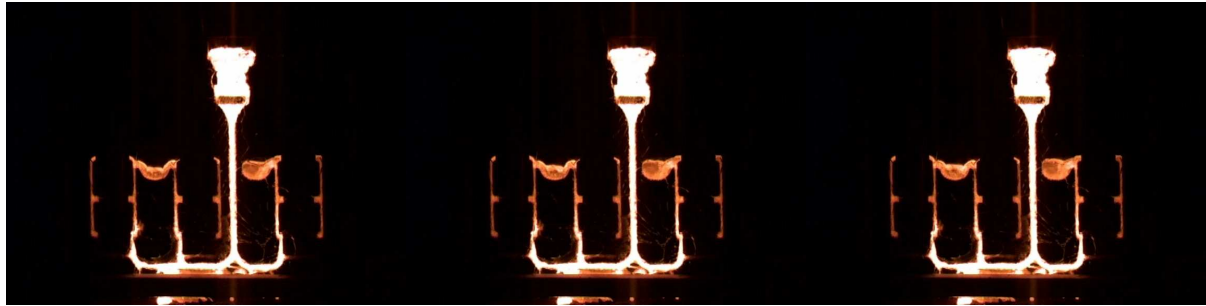
Time 3,96s



Time 4,00s

Time 4,04s

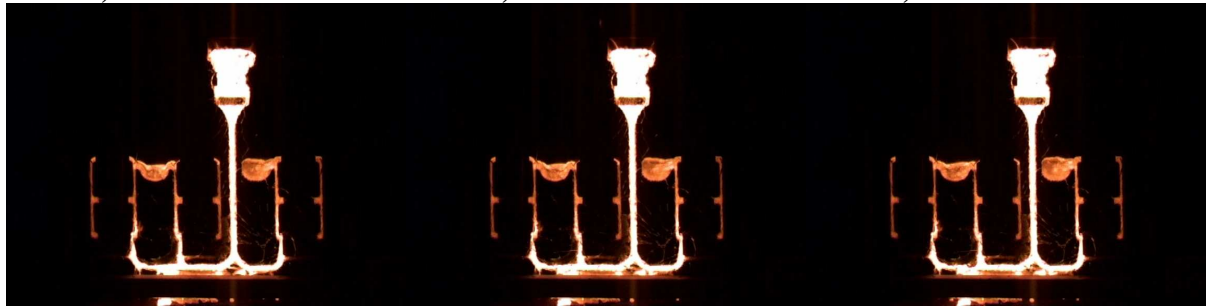
Time 4,08s



Time 4,12s

Time 4,16s

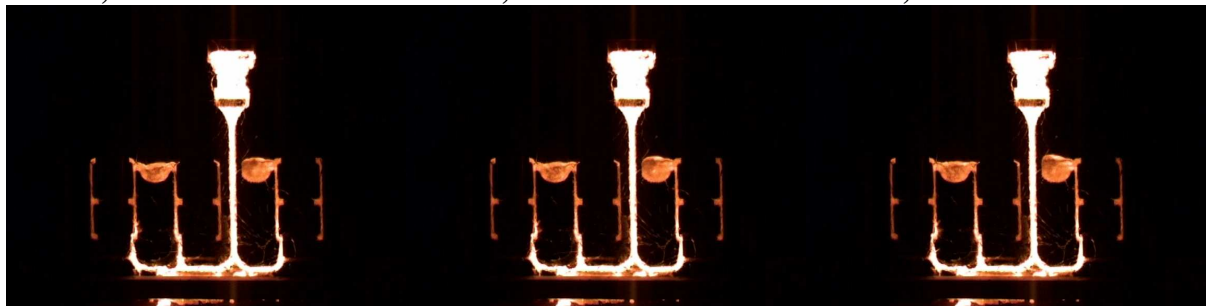
Time 4,20s



Time 4,24s

Time 4,28s

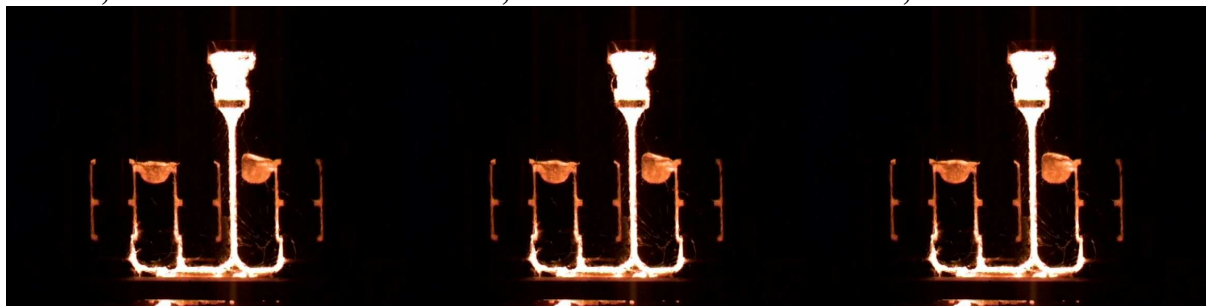
Time 4,32s



Time 4,36s

Time 4,40s

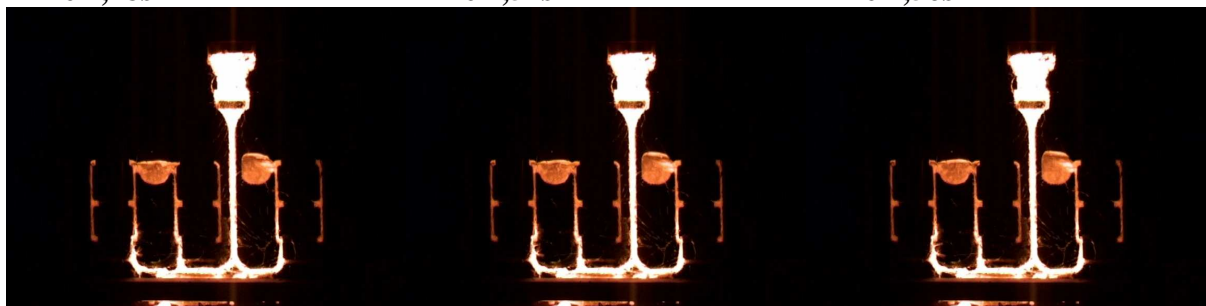
Time 4,44s



Time 4,48s

Time 4,52s

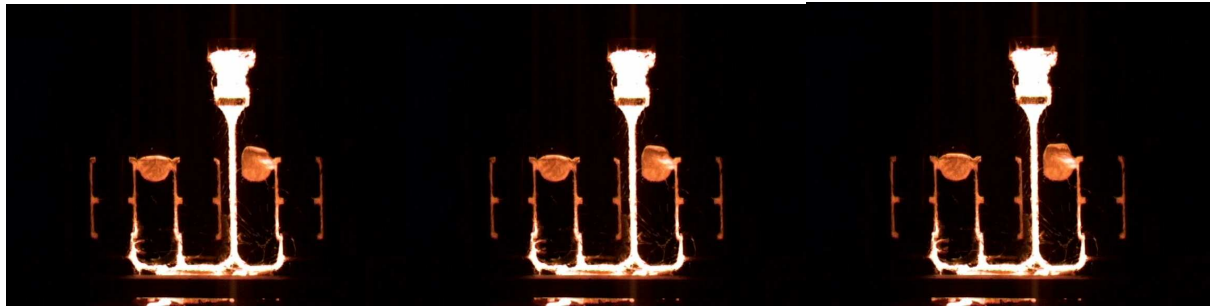
Time 4,56s



Time 4,60s

Time 4,64s

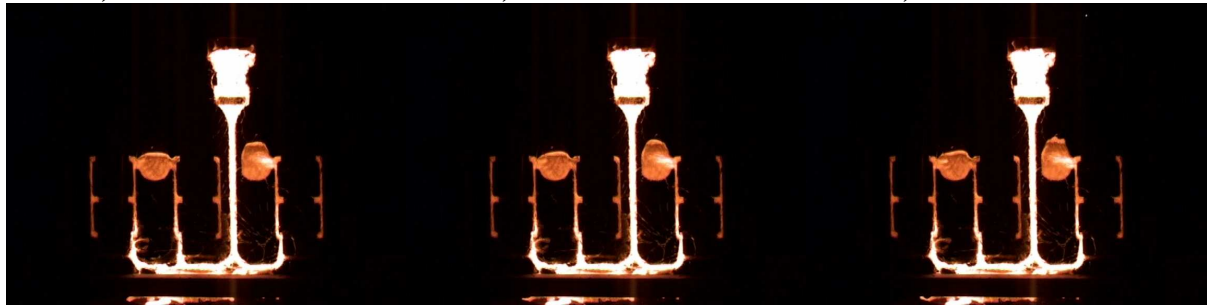
Time 4,68s



Time 4,72s

Time 4,76s

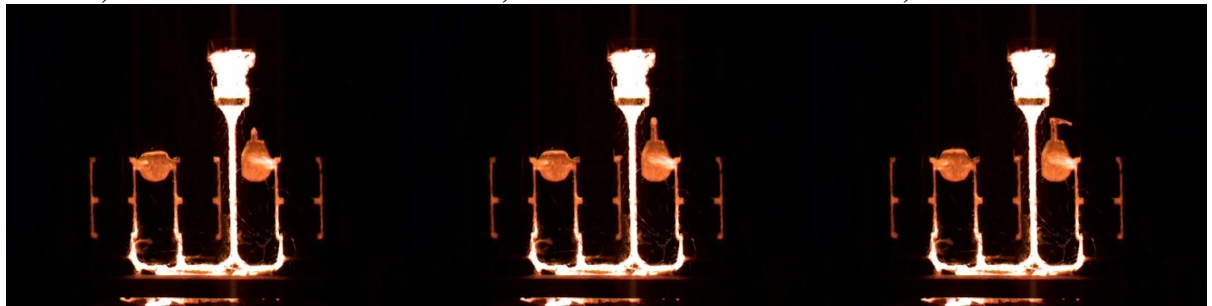
Time 4,80s



Time 4,84s

Time 4,88s

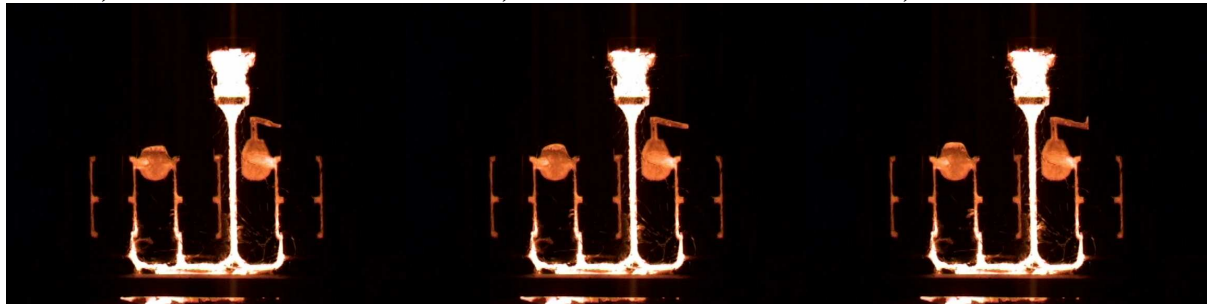
Time 4,92s



Time 4,96s

Time 5,00s

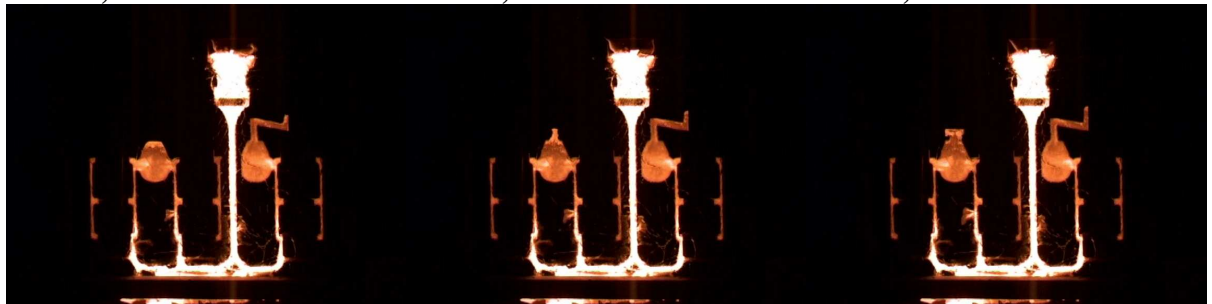
Time 5,04s



Time 5,08s

Time 5,12s

Time 5,16s

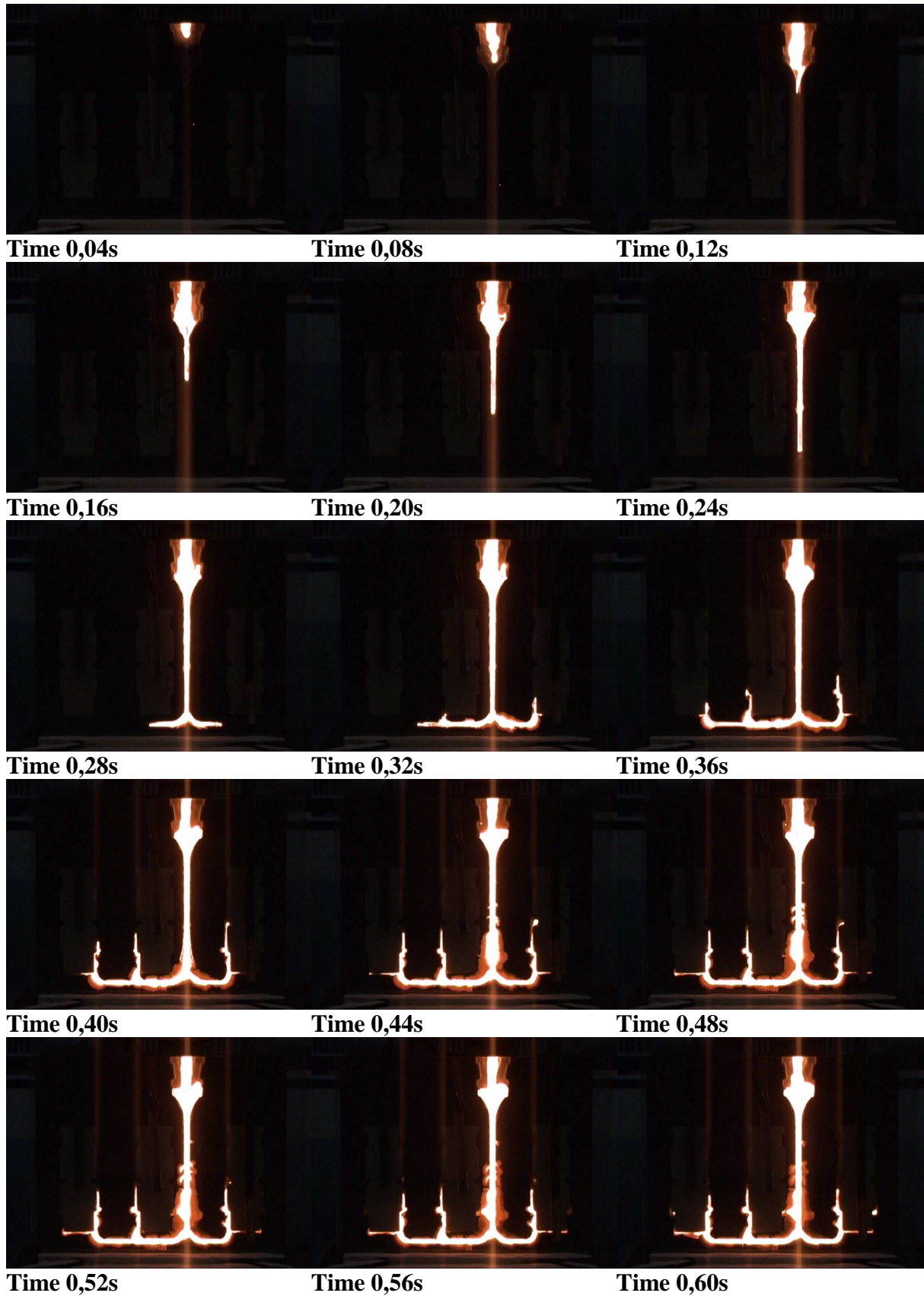


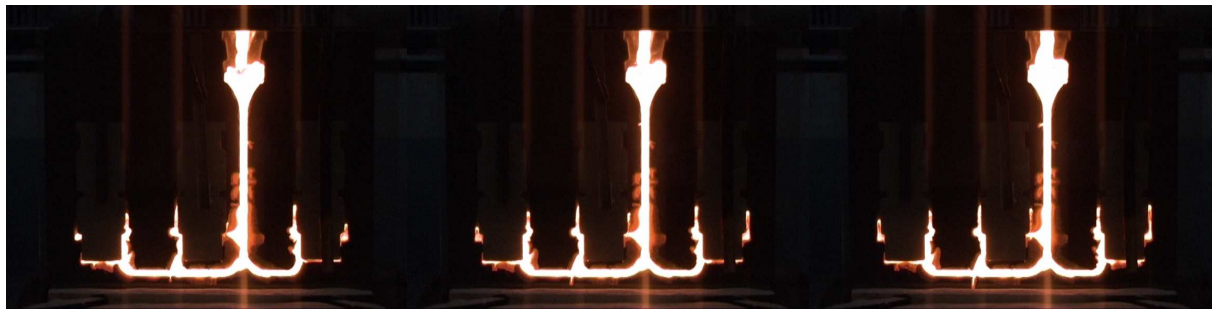
Time 5,20s

Time 5,24s

Time 5,28s

### 14.2.2 Streamlined Gating system – Without filter

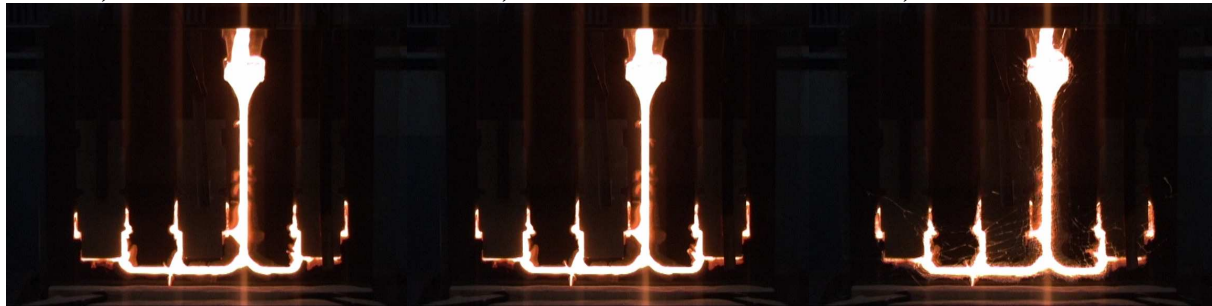




**Time 0,64s**

**Time 0,68s**

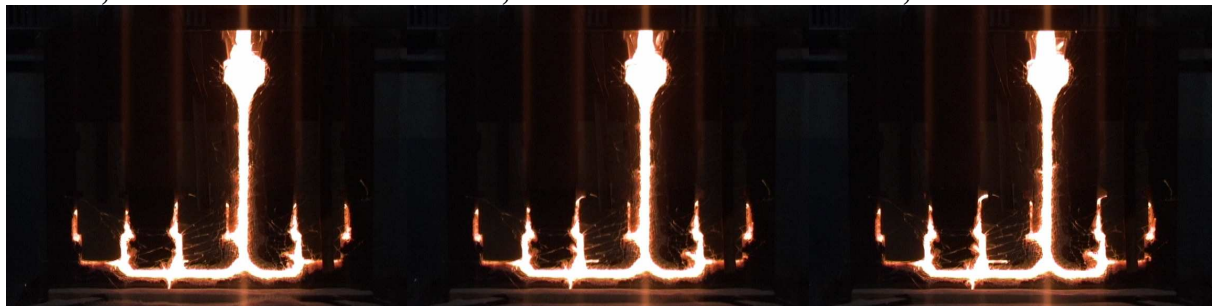
**Time 0,72s**



**Time 0,76s**

**Time 0,80s**

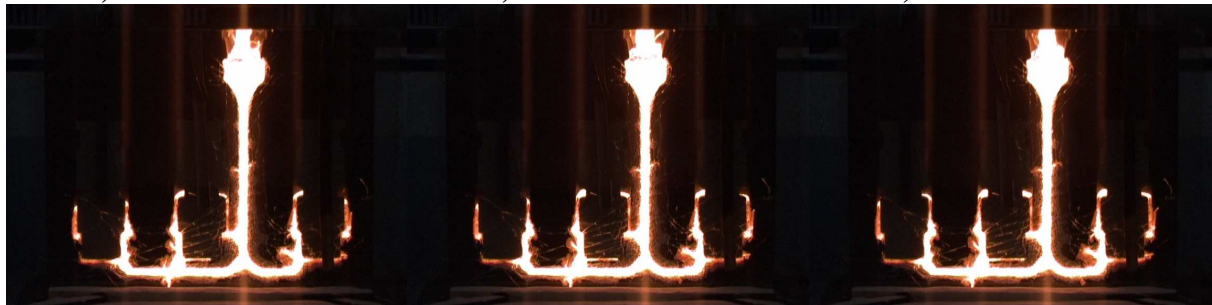
**Time 0,84s**



**Time 0,88s**

**Time 0,92s**

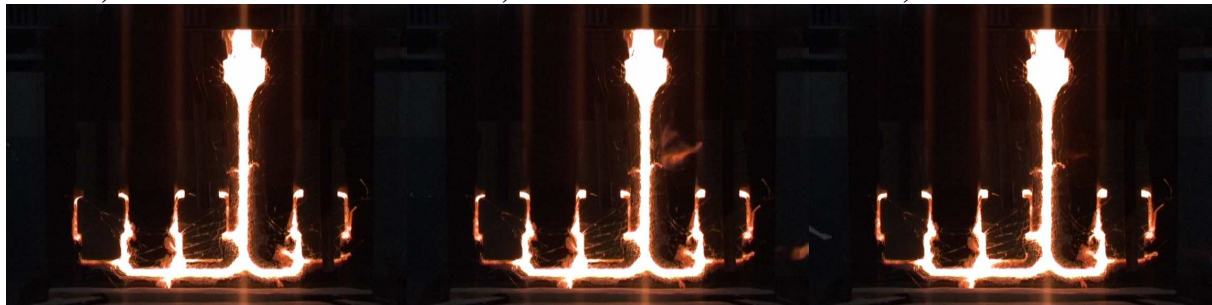
**Time 0,96s**



**Time 1,00s**

**Time 1,04s**

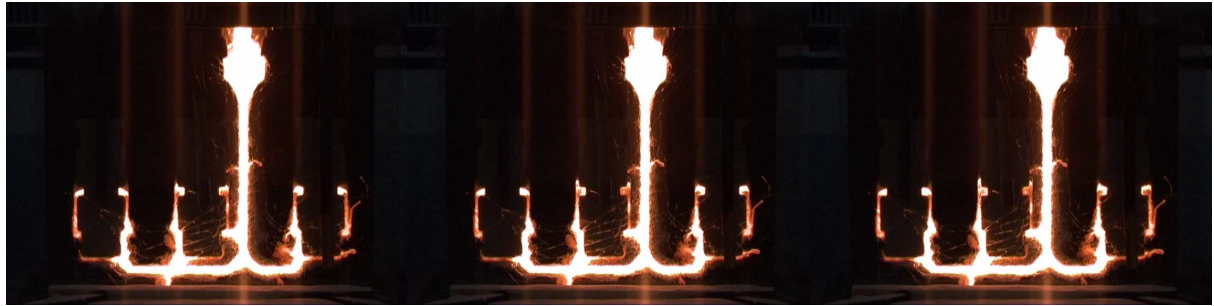
**Time 1,08s**



**Time 1,12s**

**Time 1,16s**

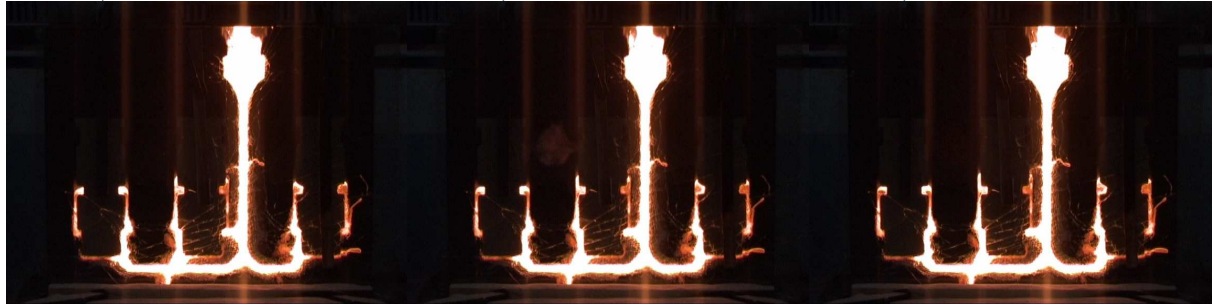
**Time 1,20s**



**Time 1,24s**

**Time 1,28s**

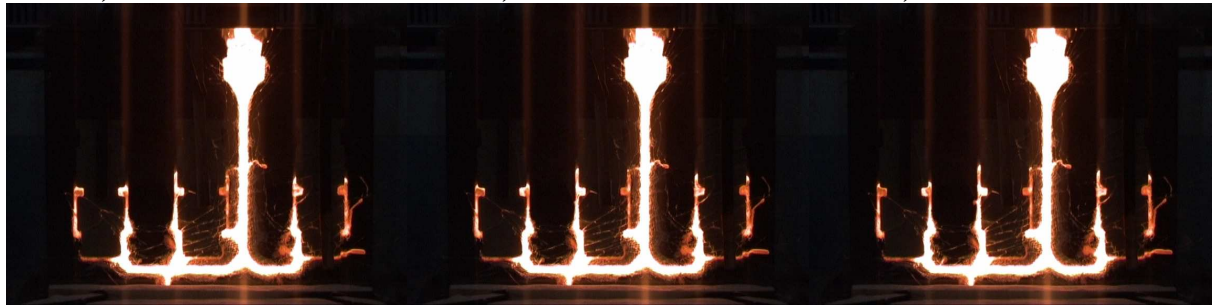
**Time 1,32s**



**Time 1,36s**

**Time 1,40s**

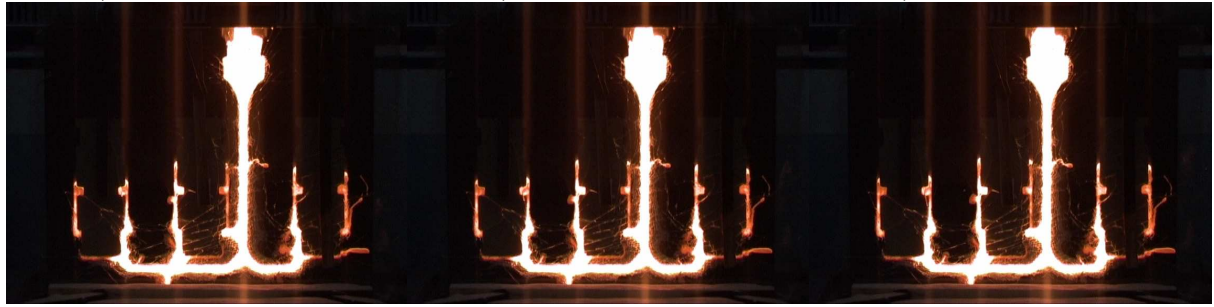
**Time 1,44s**



**Time 1,48s**

**Time 1,52s**

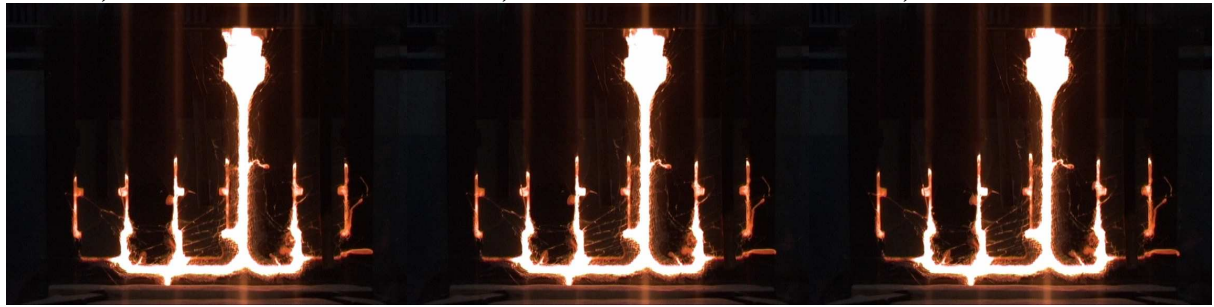
**Time 1,56s**



**Time 1,60s**

**Time 1,64s**

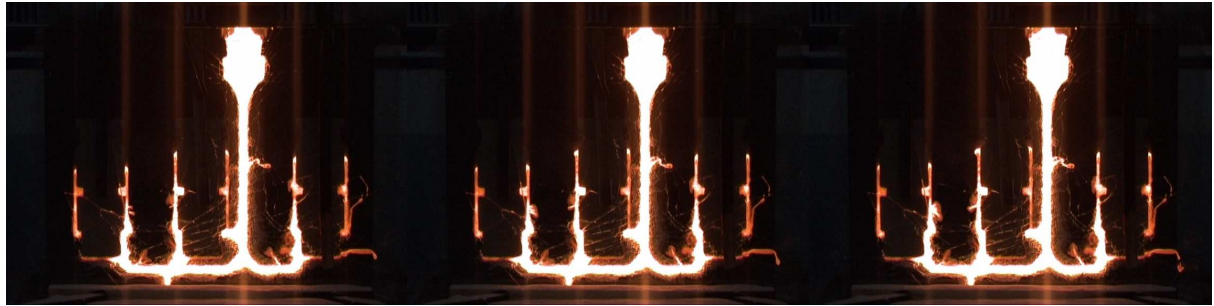
**Time 1,68s**



**Time 1,72s**

**Time 1,76s**

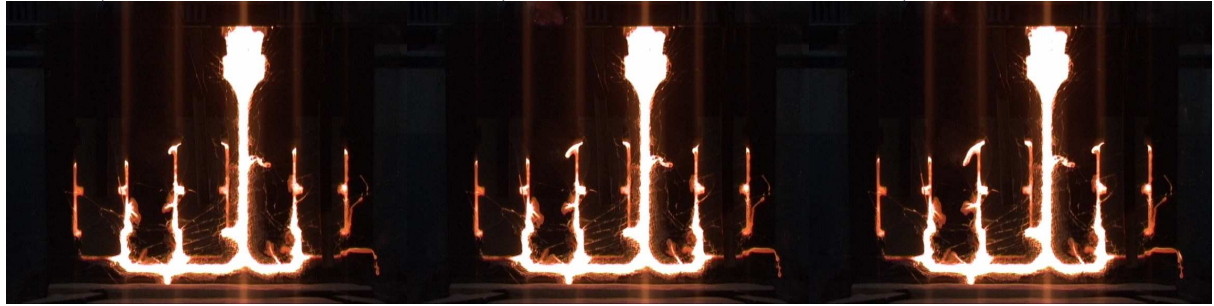
**Time 1,80s**



Time 1,84s

Time 1,88s

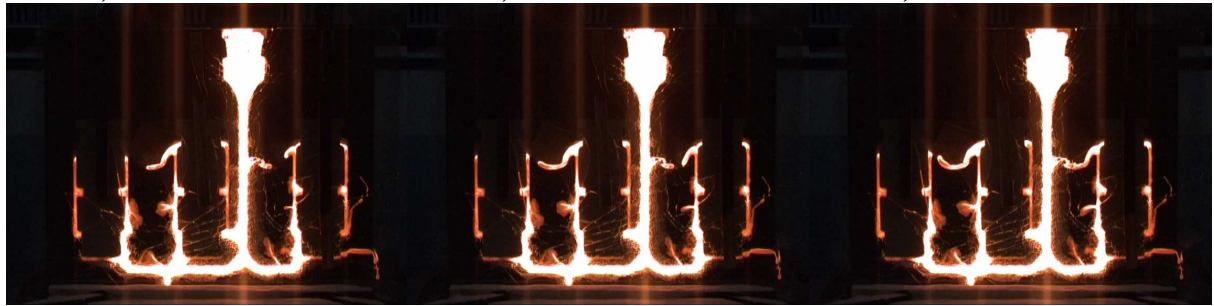
Time 1,92s



Time 1,96s

Time 2,00s

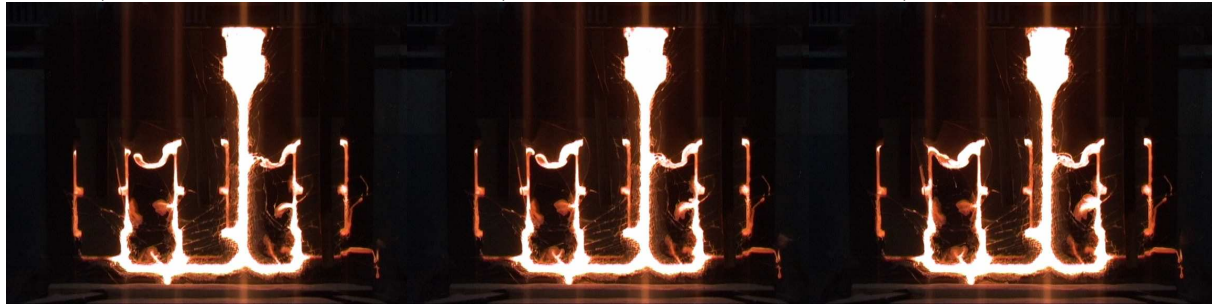
Time 2,04s



Time 2,08s

Time 2,12s

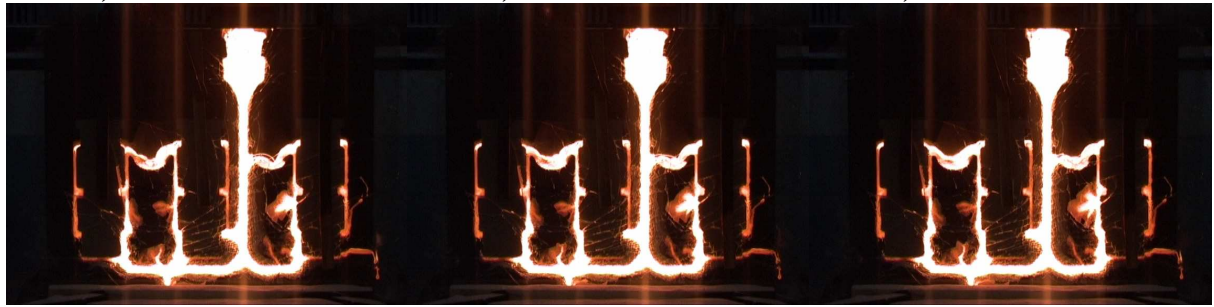
Time 2,16s



Time 2,20s

Time 2,24s

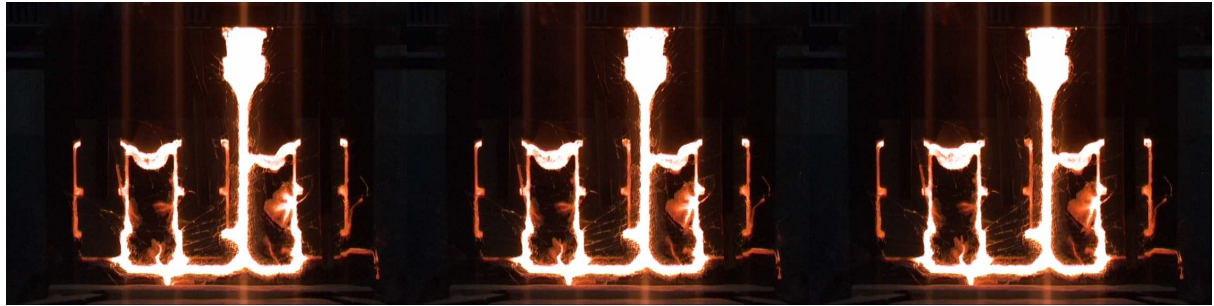
Time 2,28s



Time 2,32s

Time 2,36s

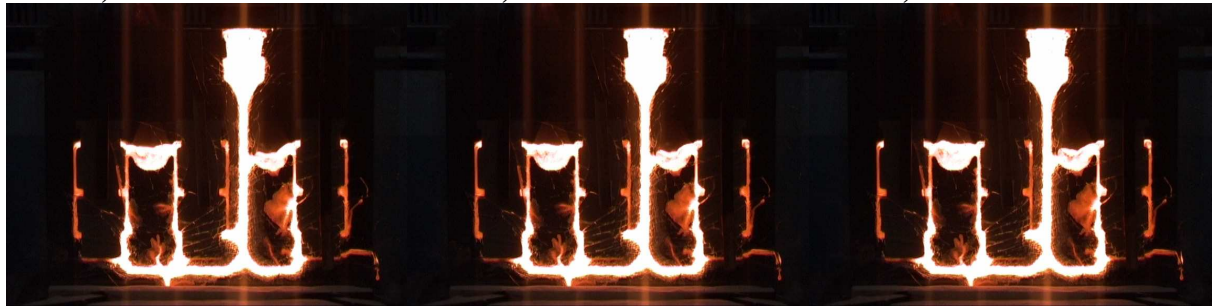
Time 2,40s



Time 2,44s

Time 2,48s

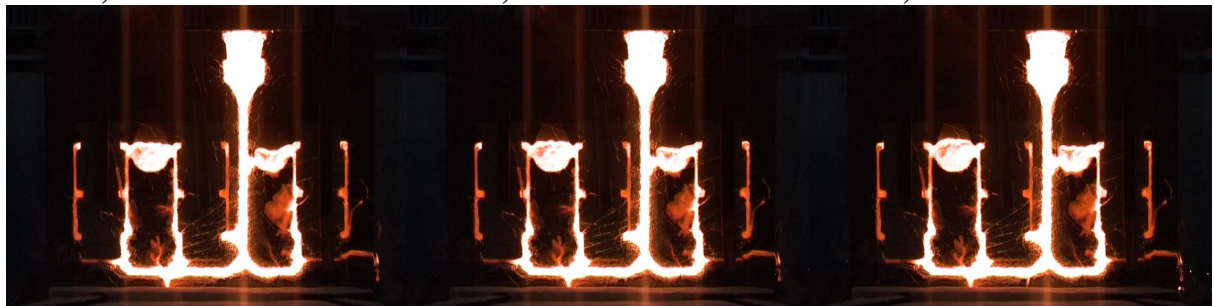
Time 2,52s



Time 2,56s

Time 2,60s

Time 2,64s



Time 2,68s

Time 2,72s

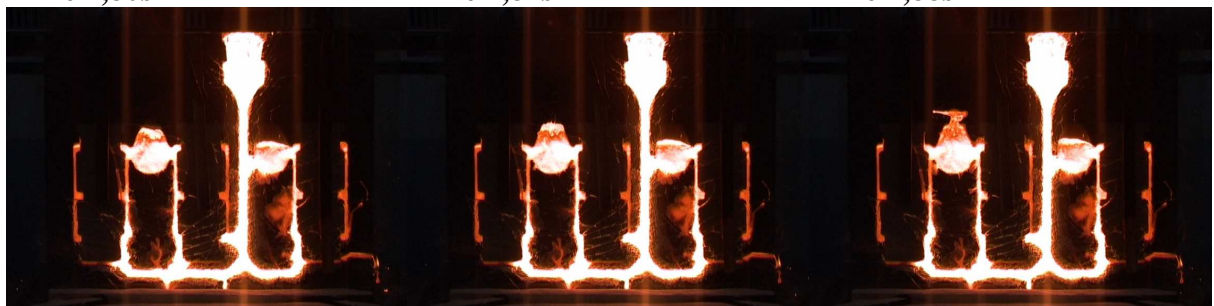
Time 2,76s



Time 2,80s

Time 2,84s

Time 2,88s

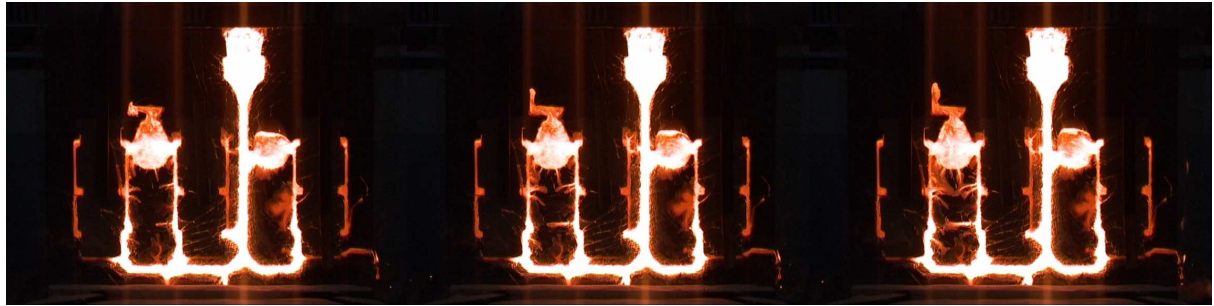


Time 2,92s

Time 2,96s

Time 3,00s

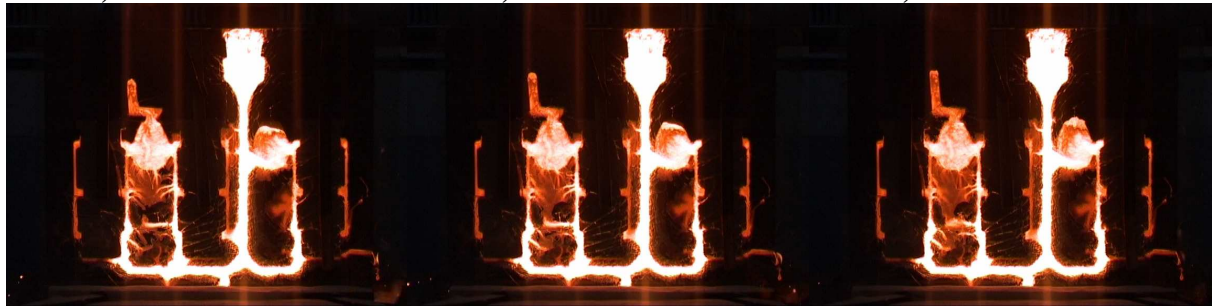




Time 3,04s

Time 3,08s

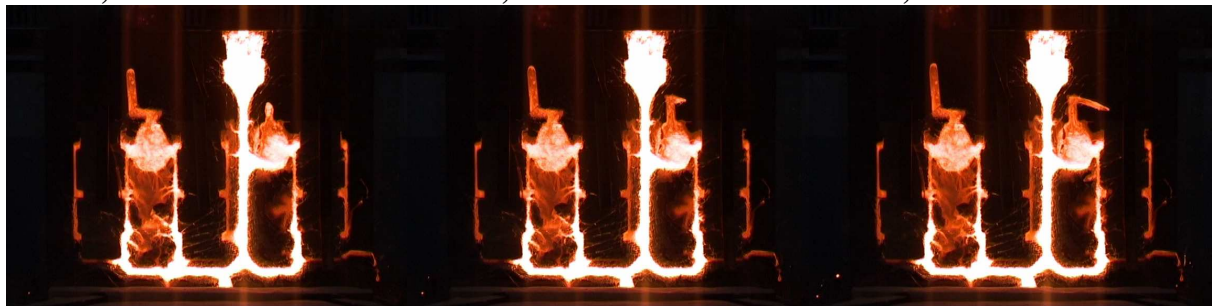
Time 3,12s



Time 3,16s

Time 3,20s

Time 3,24s

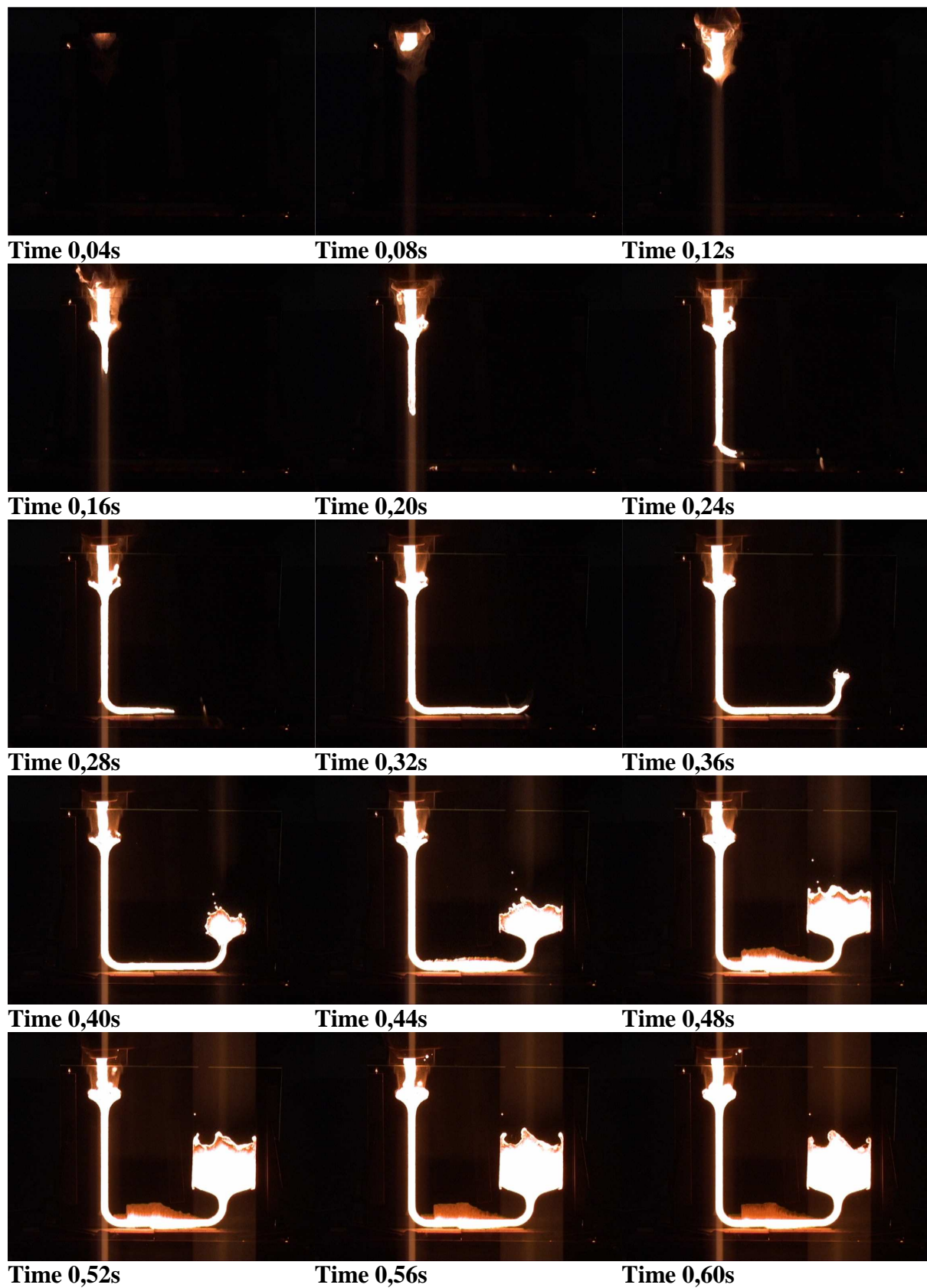


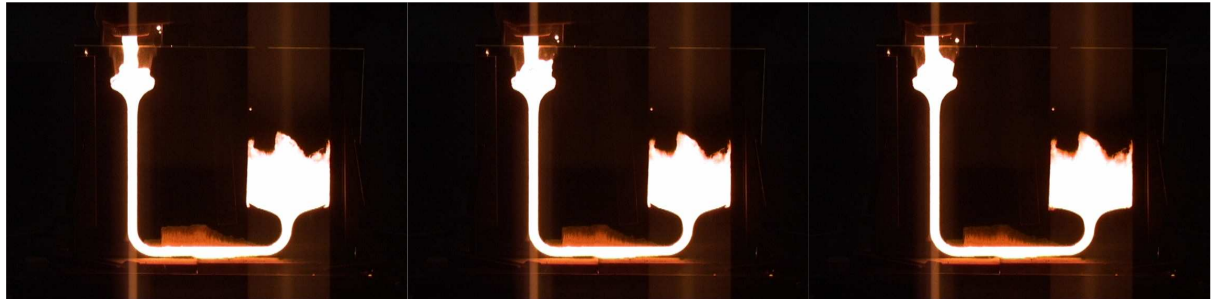
Time 3,28s

Time 3,32s

Time 3,36s

### 14.3 Appendix 3 – Runner width

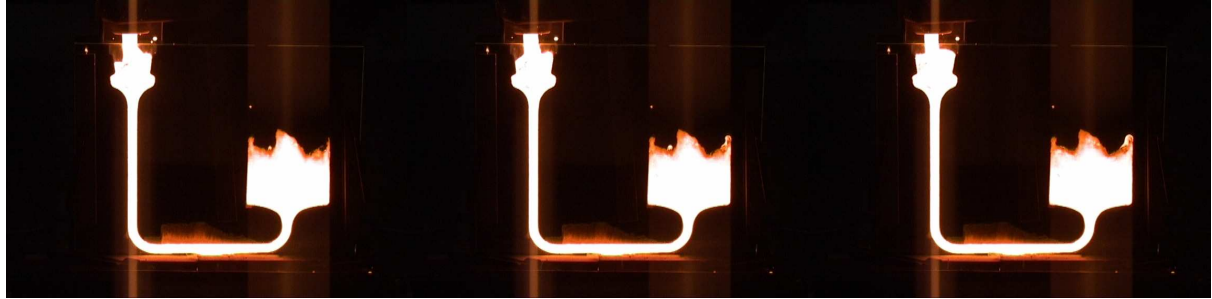




**Time 0,64s**

**Time 0,68s**

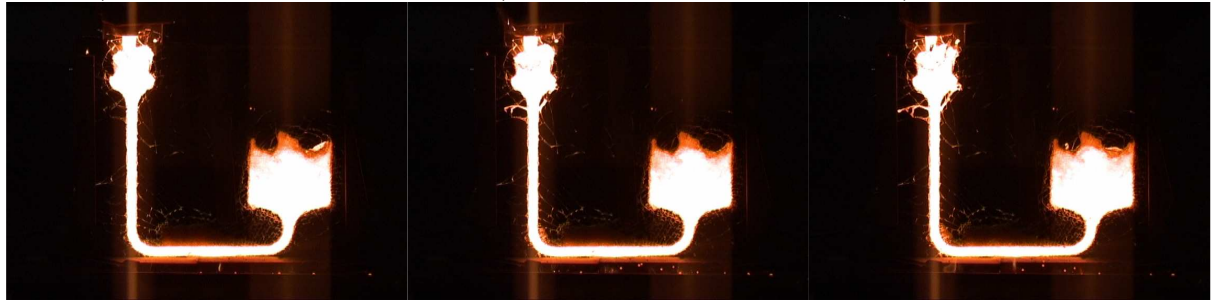
**Time 0,72s**



**Time 0,76s**

**Time 0,80s**

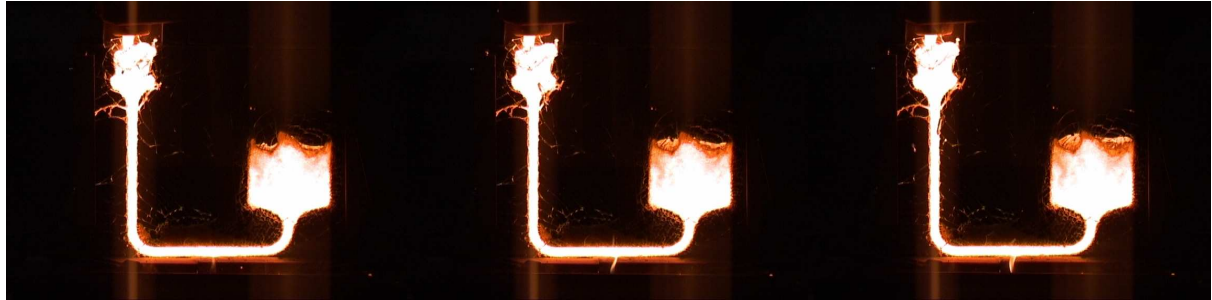
**Time 0,84s**



**Time 0,88s**

**Time 0,92s**

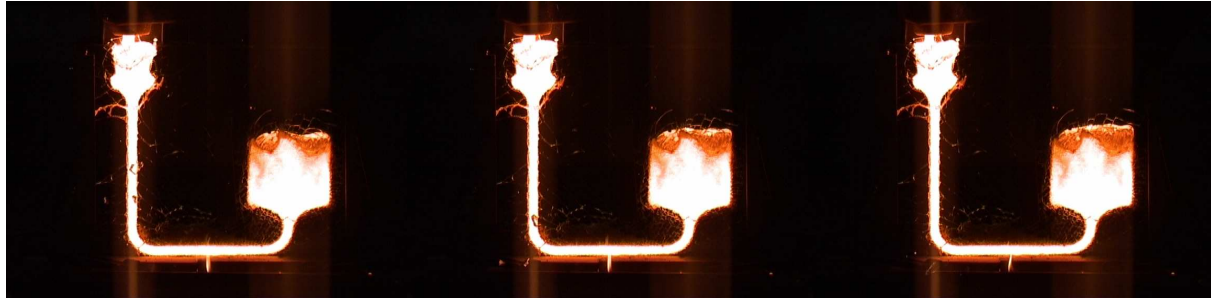
**Time 0,96s**



**Time 1,00s**

**Time 1,04s**

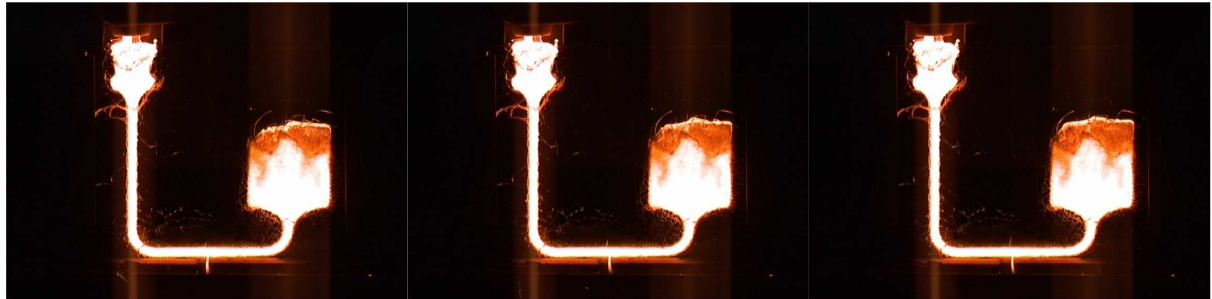
**Time 1,08s**



**Time 1,12s**

**Time 1,16s**

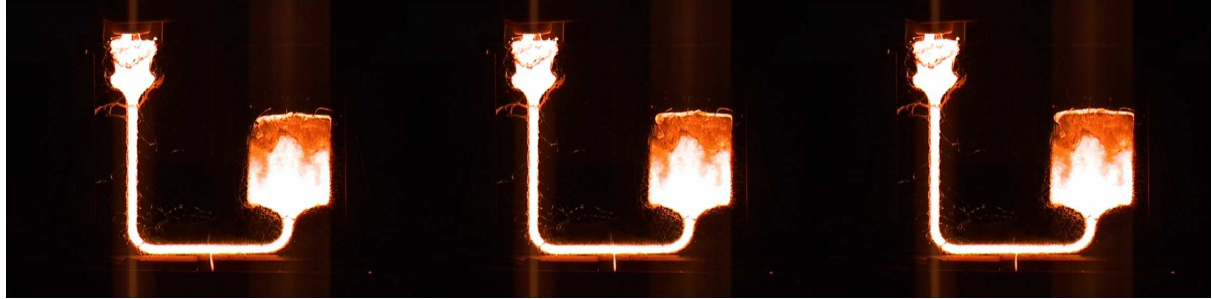
**Time 1,20s**



**Time 1,24s**

**Time 1,28s**

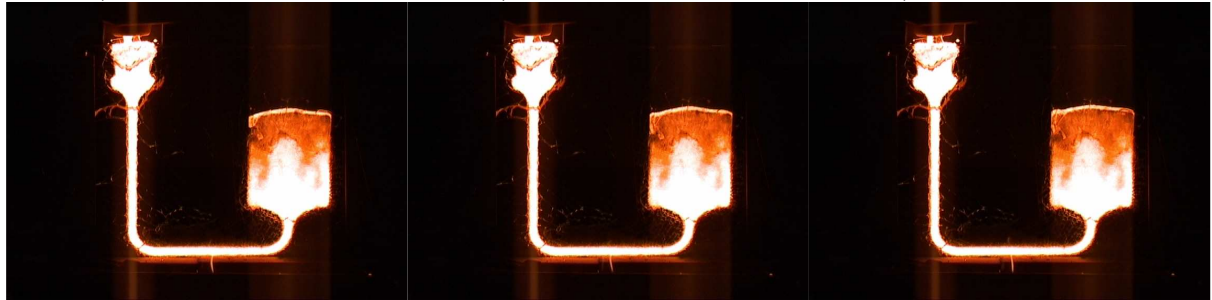
**Time 1,32s**



**Time 1,36s**

**Time 1,40s**

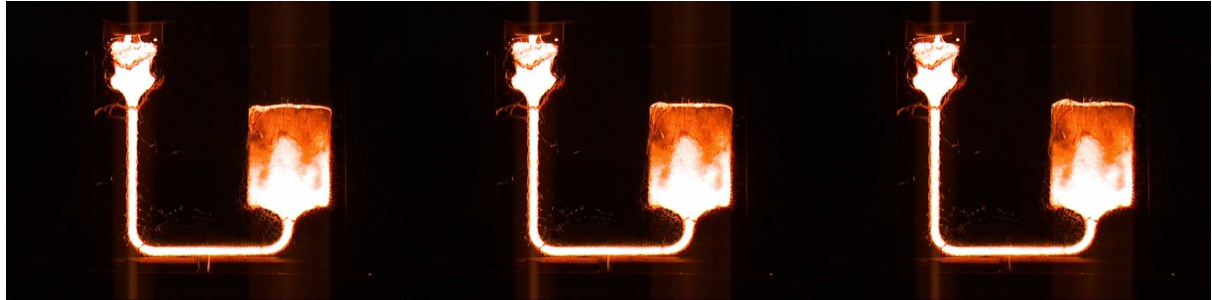
**Time 1,44s**



**Time 1,48s**

**Time 1,52s**

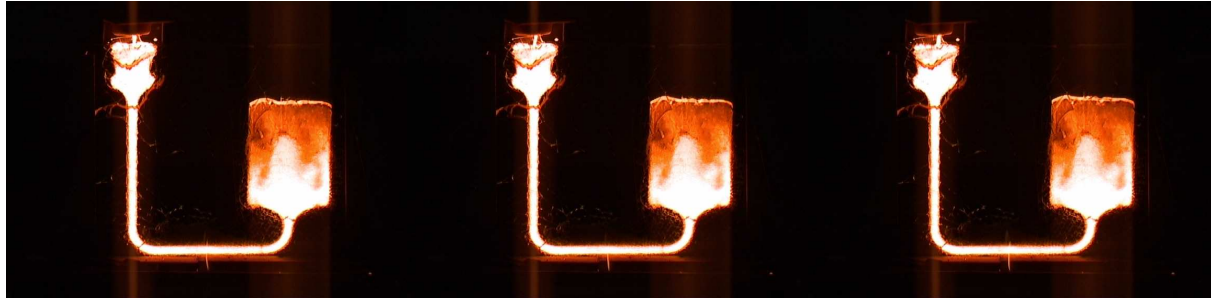
**Time 1,56s**



**Time 1,60s**

**Time 1,64s**

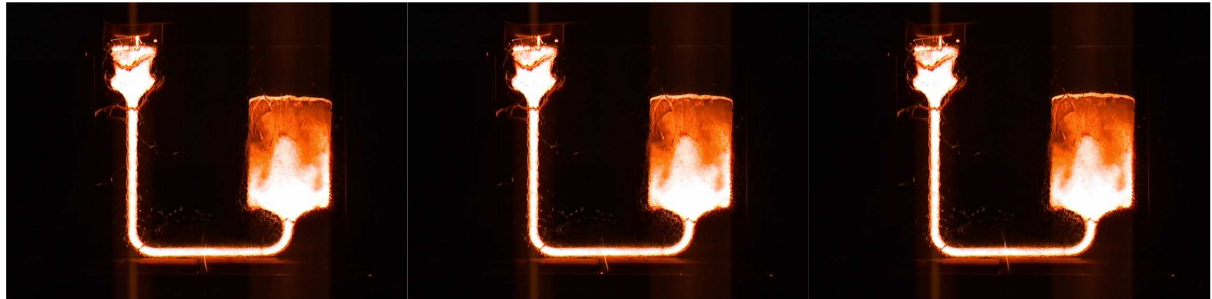
**Time 1,68s**



**Time 1,72s**

**Time 1,76s**

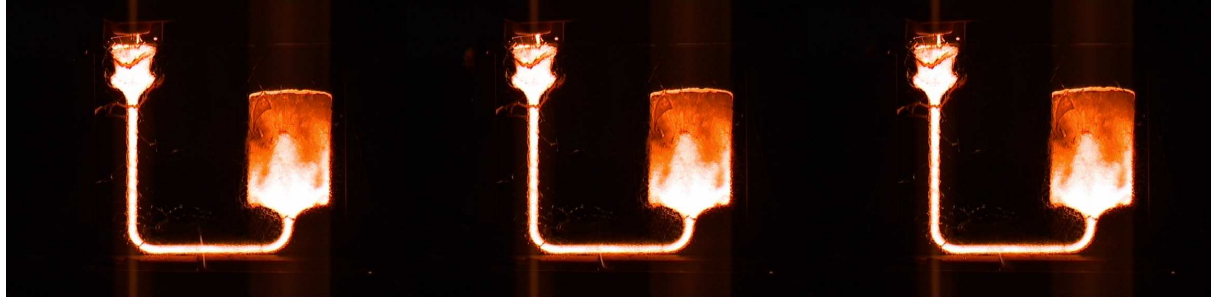
**Time 1,80s**



**Time 1,84s**

**Time 1,88s**

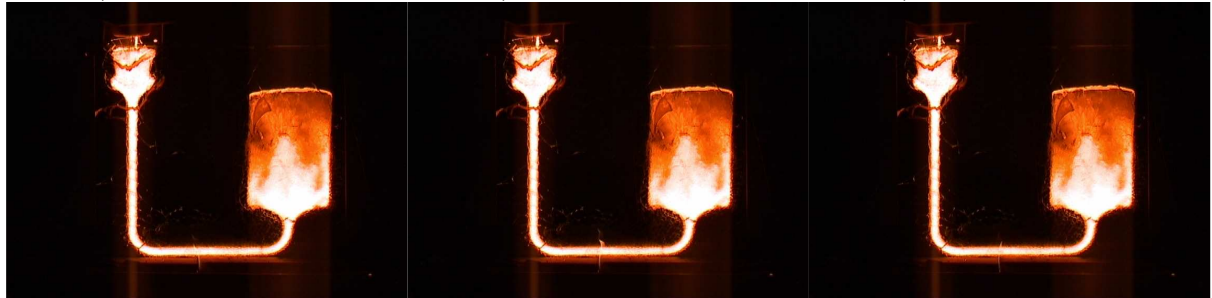
**Time 1,92s**



**Time 1,96s**

**Time 2,00s**

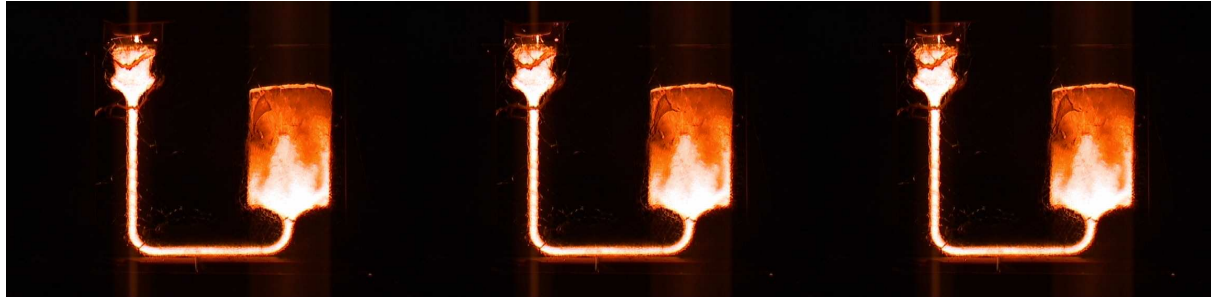
**Time 2,04s**



**Time 2,08s**

**Time 2,12s**

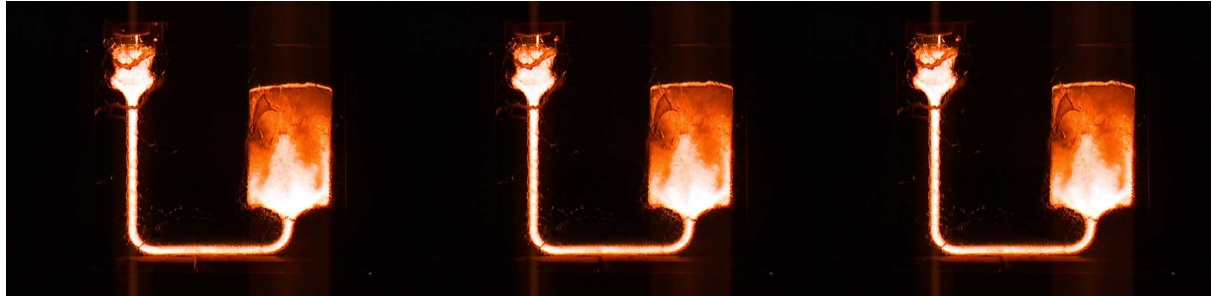
**Time 2,16s**



**Time 2,20s**

**Time 2,24s**

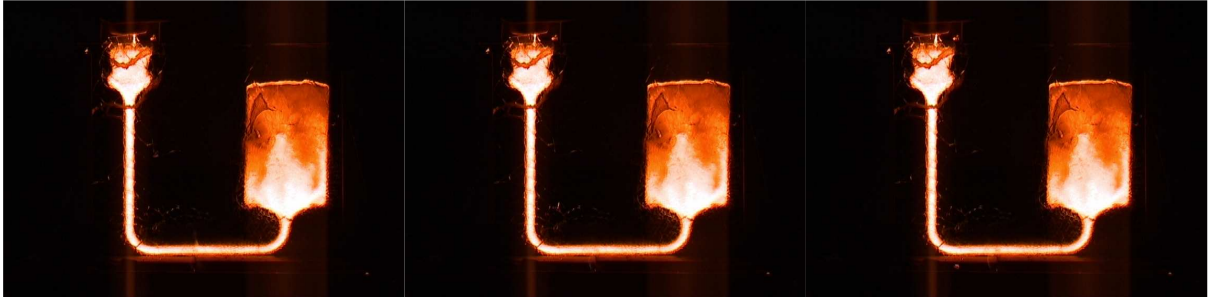
**Time 2,28s**



**Time 2,32s**

**Time 2,36s**

**Time 2,40s**



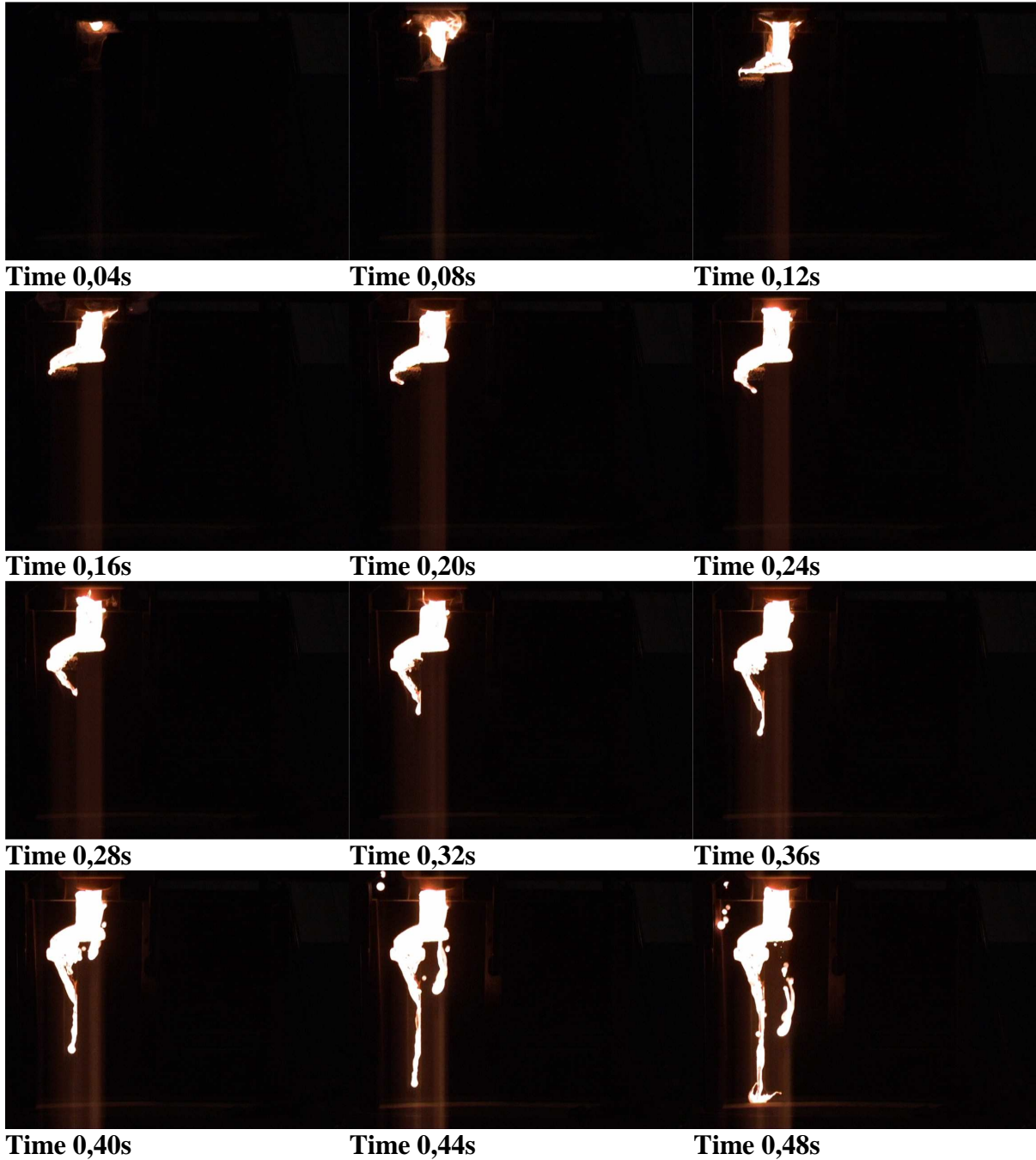
**Time 2,44s**

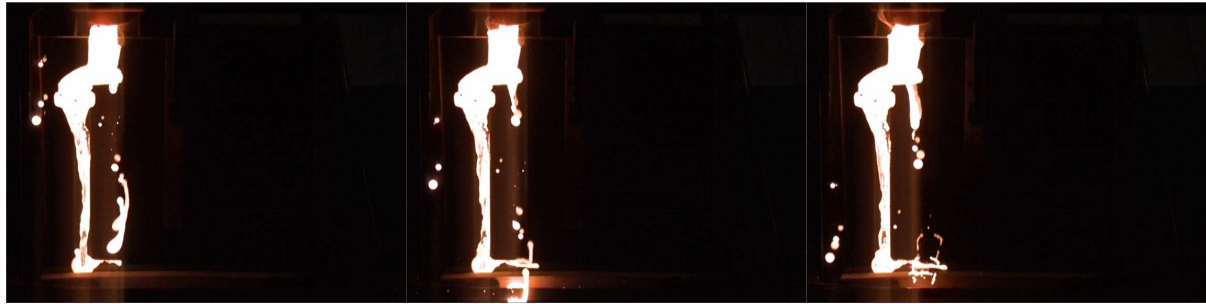
**Time 2,48s**

**Time 2,52s**

## 14.4 Appendix 4 – Filtration

### 14.4.1 Vertical 1 (a foam filter is used)

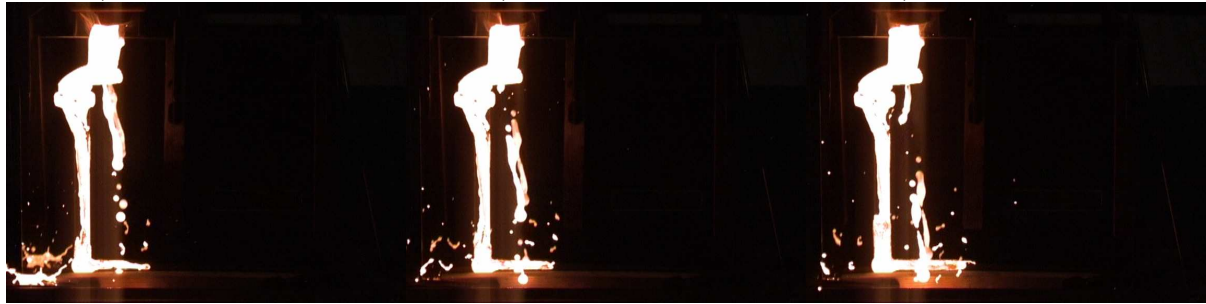




Time 0,52s

Time 0,56s

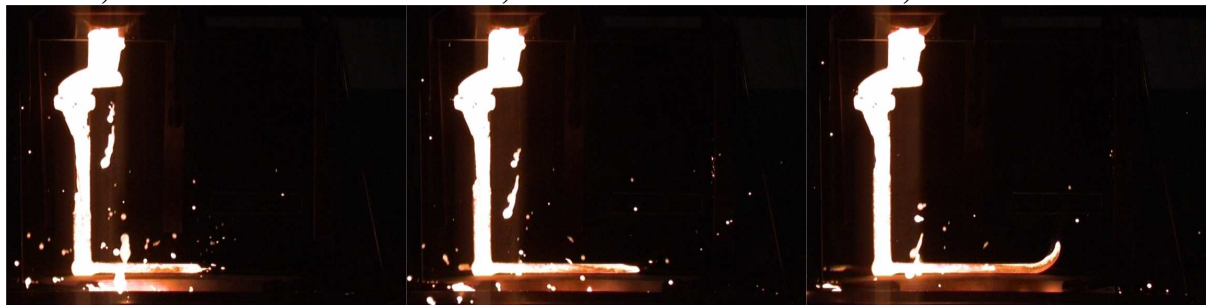
Time 0,60s



Time 0,64s

Time 0,68s

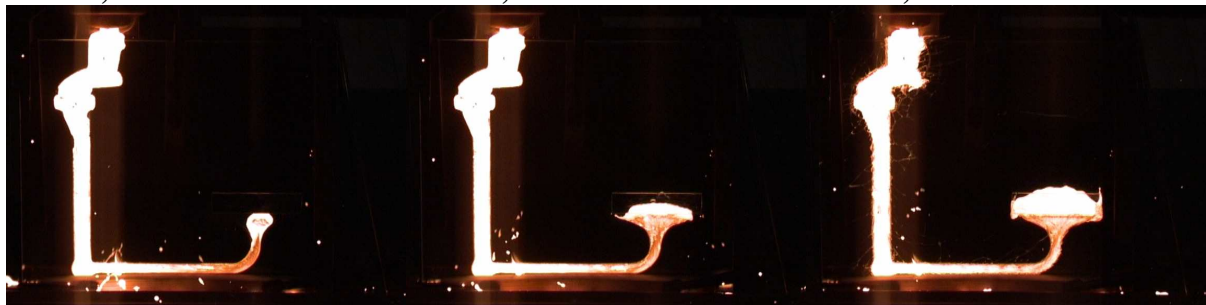
Time 0,72s



Time 0,76s

Time 0,80s

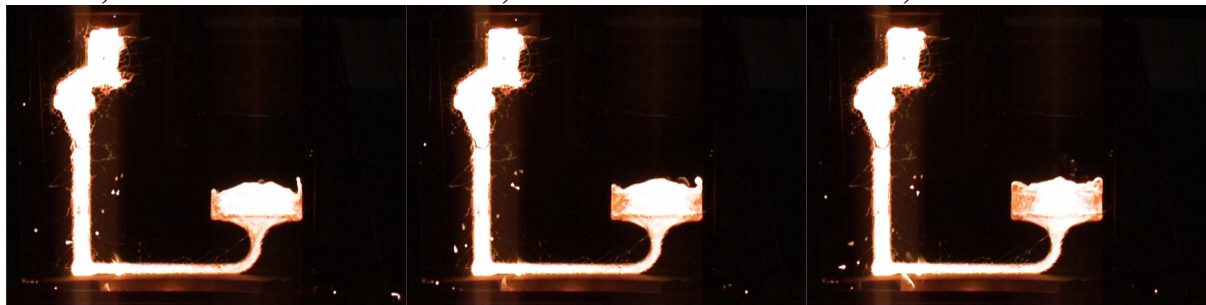
Time 0,84s



Time 0,88s

Time 0,92s

Time 0,96s

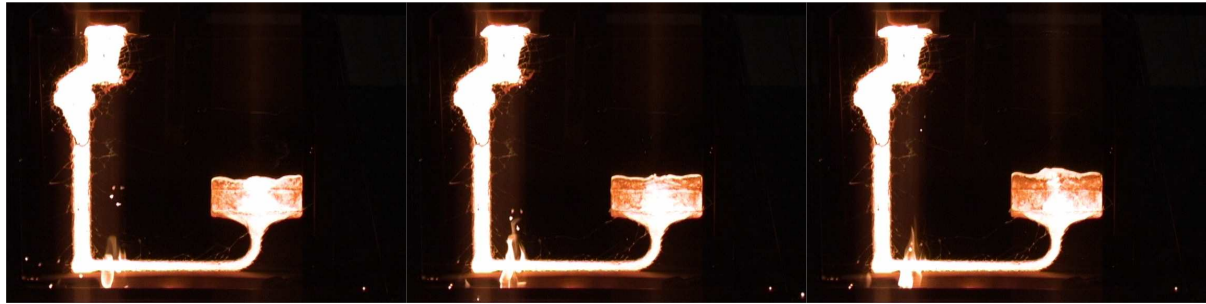


Time 1,00s

Time 1,04s

Time 1,08s

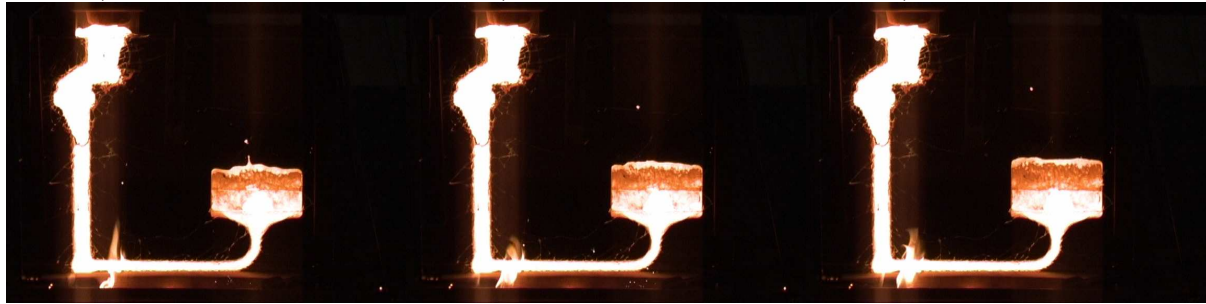




Time 1,12s

Time 1,16s

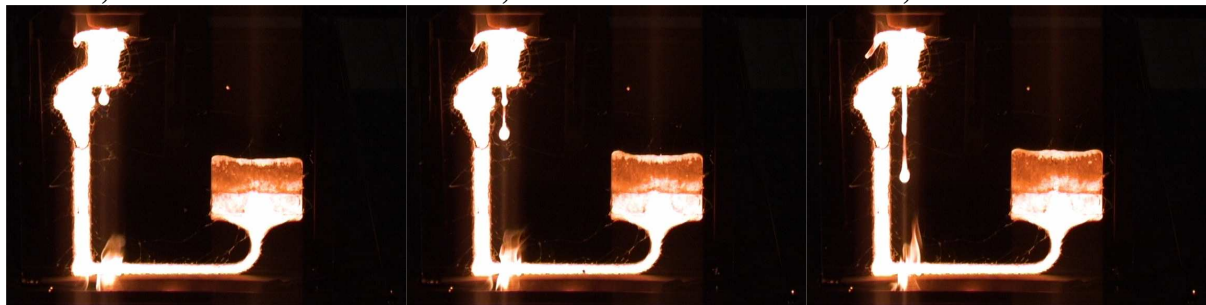
Time 1,20s



Time 1,24s

Time 1,28s

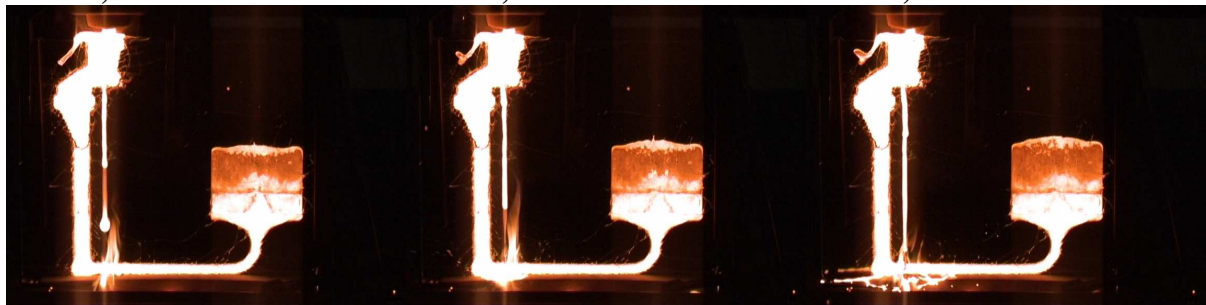
Time 1,32s



Time 1,36s

Time 1,40s

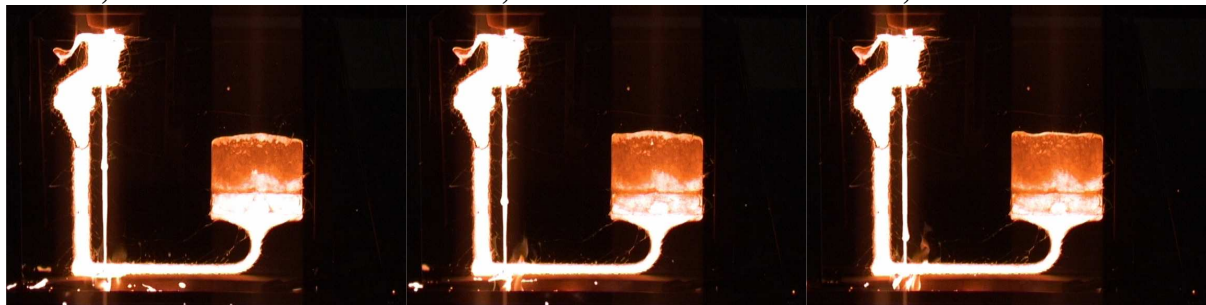
Time 1,44s



Time 1,48s

Time 1,52s

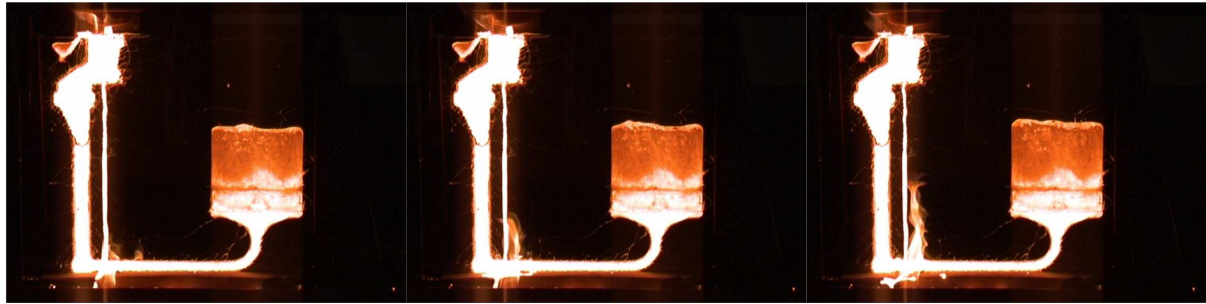
Time 1,56s



Time 1,60s

Time 1,64s

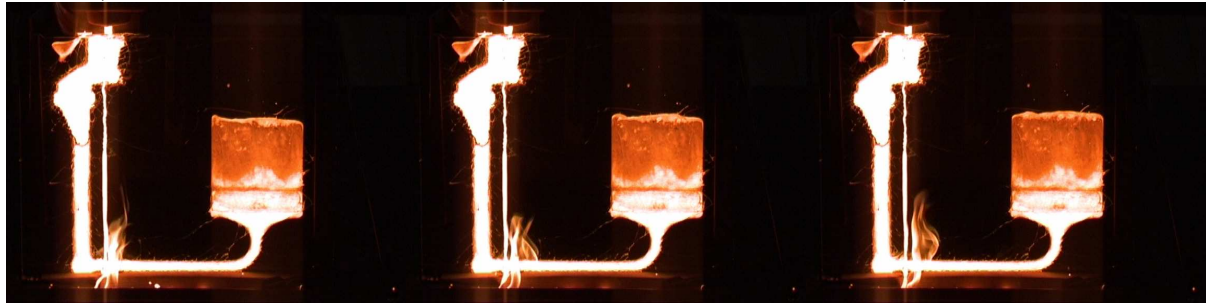
Time 1,68s



Time 1,72s

Time 1,76s

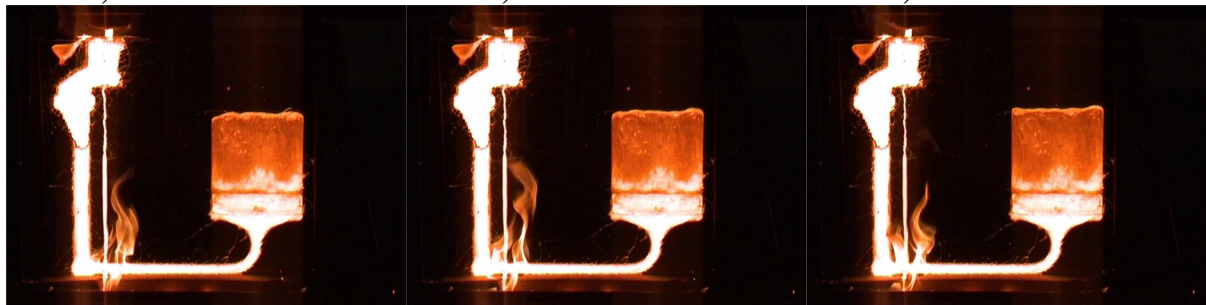
Time 1,80s



Time 1,84s

Time 1,88s

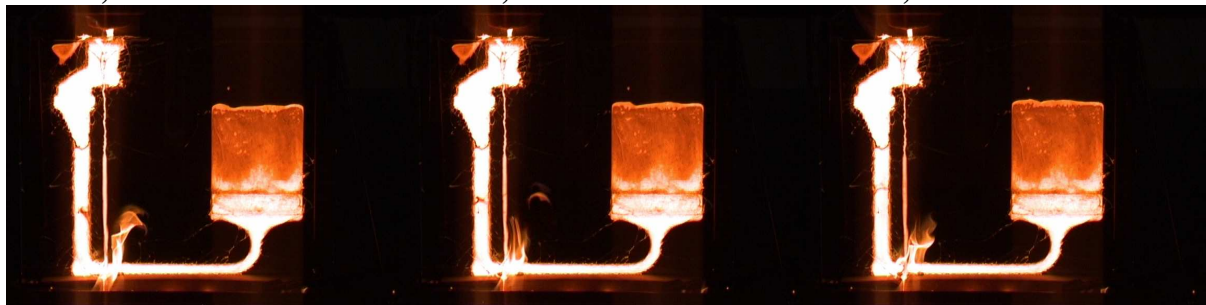
Time 1,92s



Time 1,96s

Time 2,00s

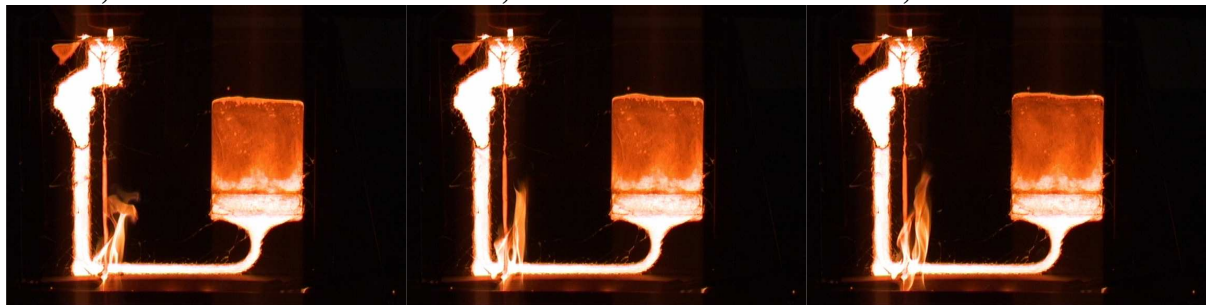
Time 2,04s



Time 2,08s

Time 2,12s

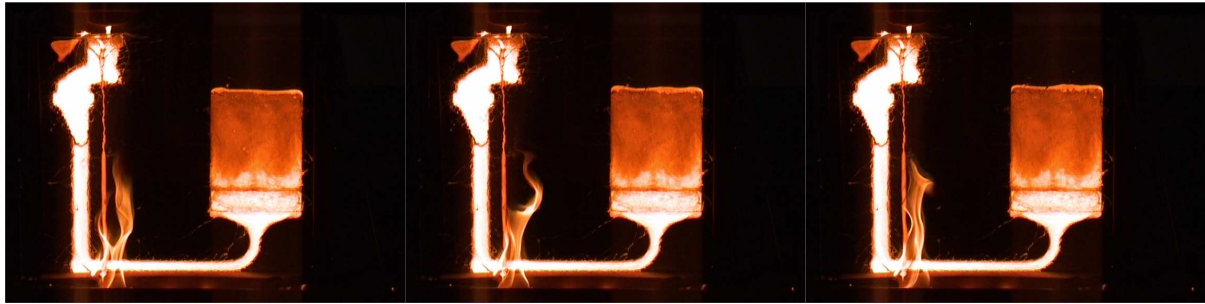
Time 2,16s



Time 2,20s

Time 2,24s

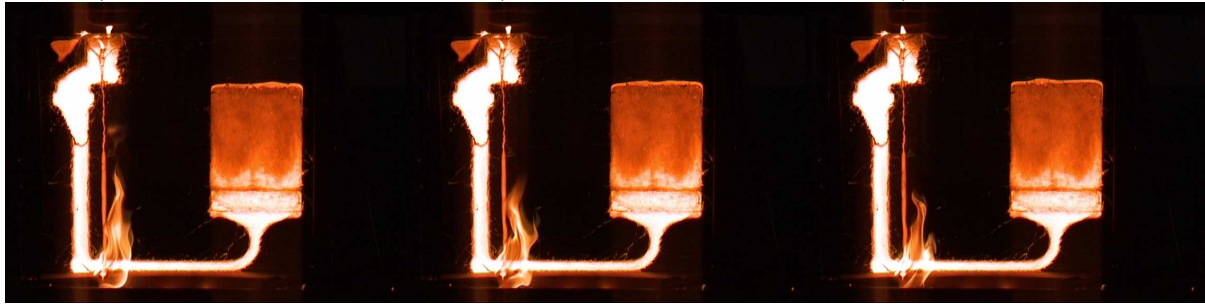
Time 2,28s



**Time 2,32s**

**Time 2,36s**

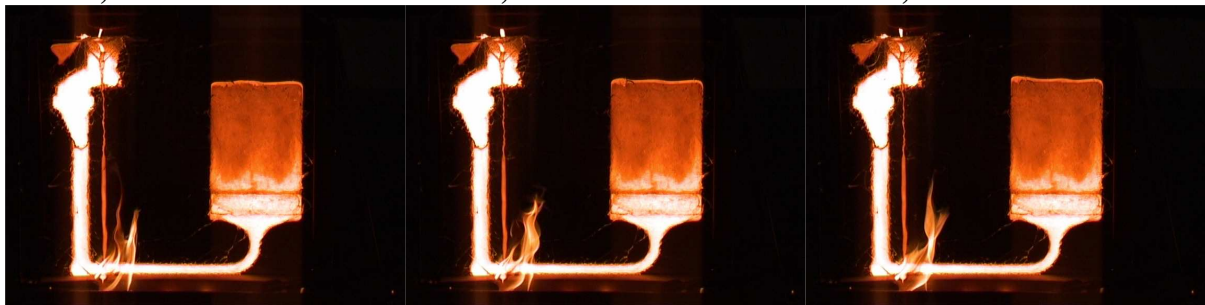
**Time 2,40s**



**Time 2,44s**

**Time 2,48s**

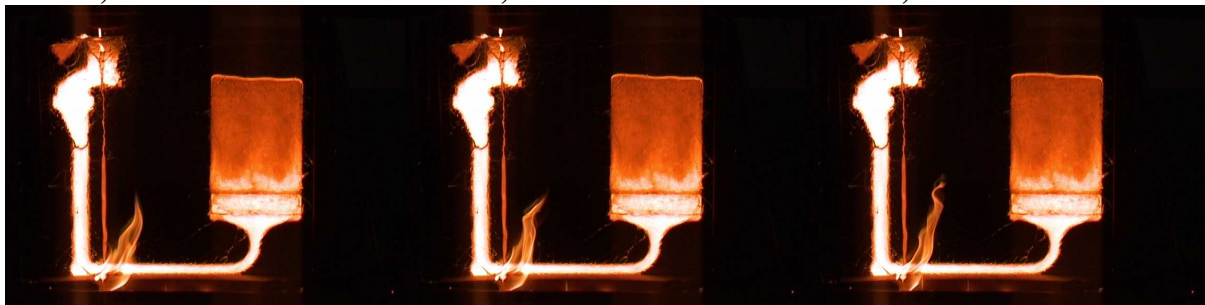
**Time 2,52s**



**Time 2,56s**

**Time 2,60s**

**Time 2,64s**

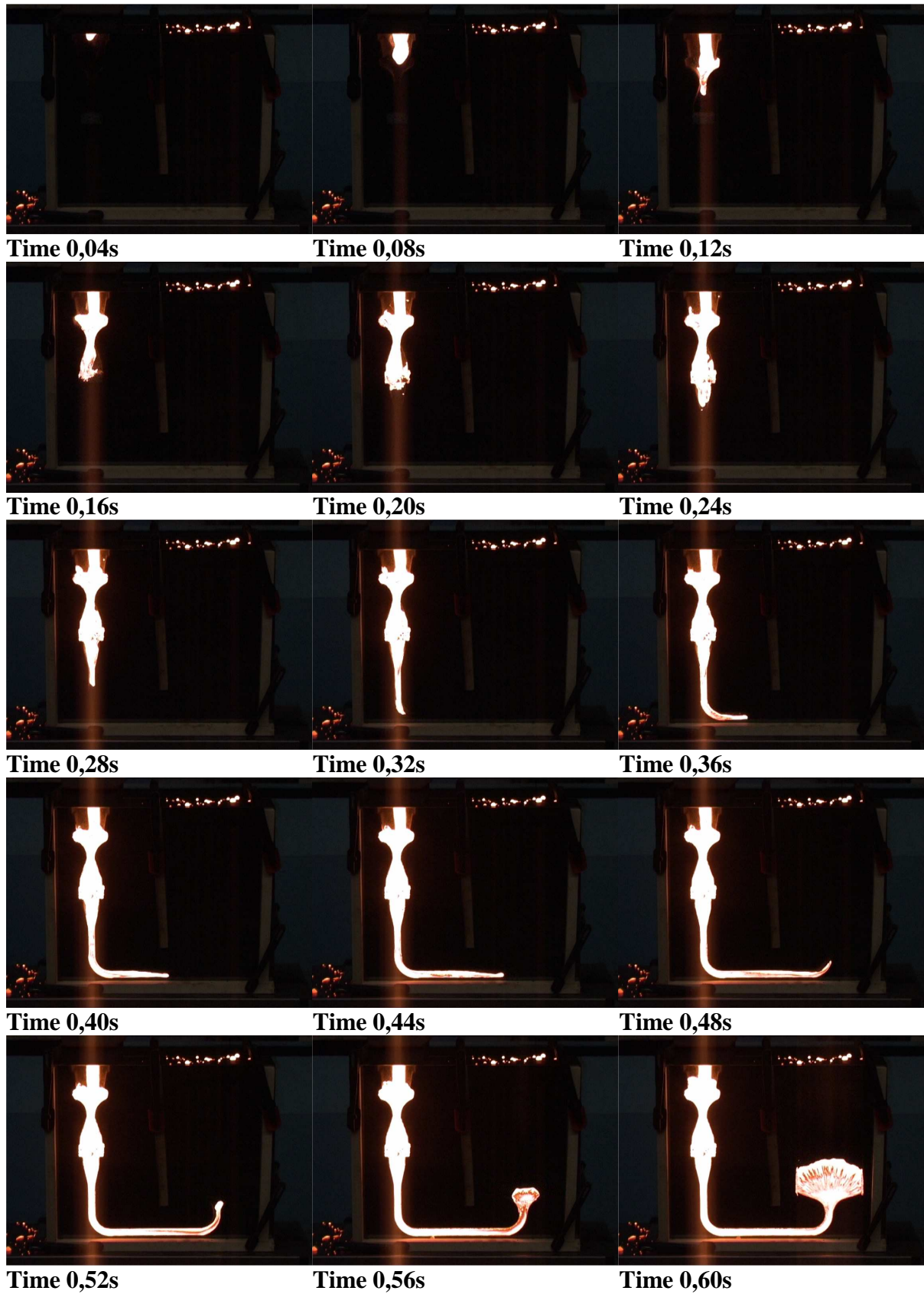


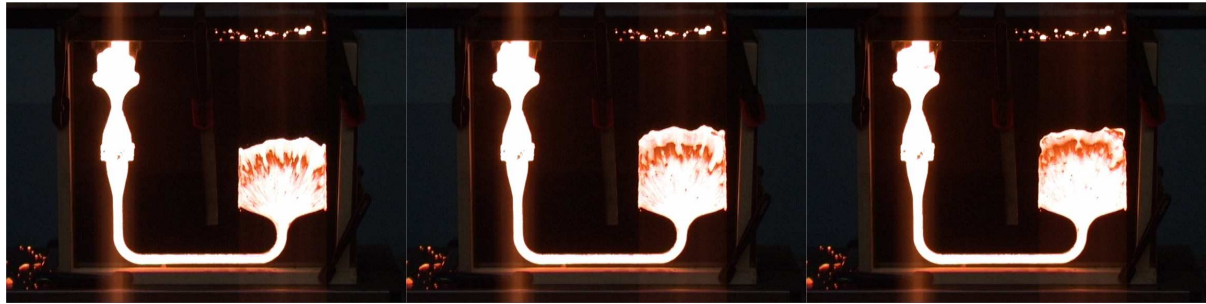
**Time 2,68s**

**Time 2,72s**

**Time 2,76s**

14.4.2 Vertical 2 (a foam filter is used)

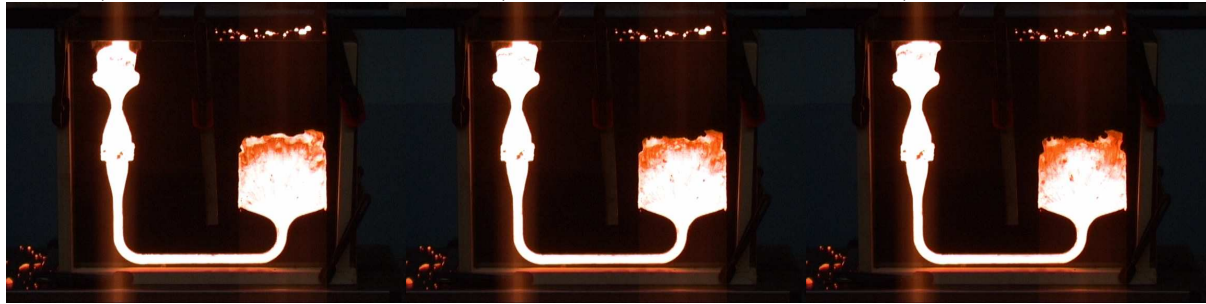




**Time 0,64s**

**Time 0,68s**

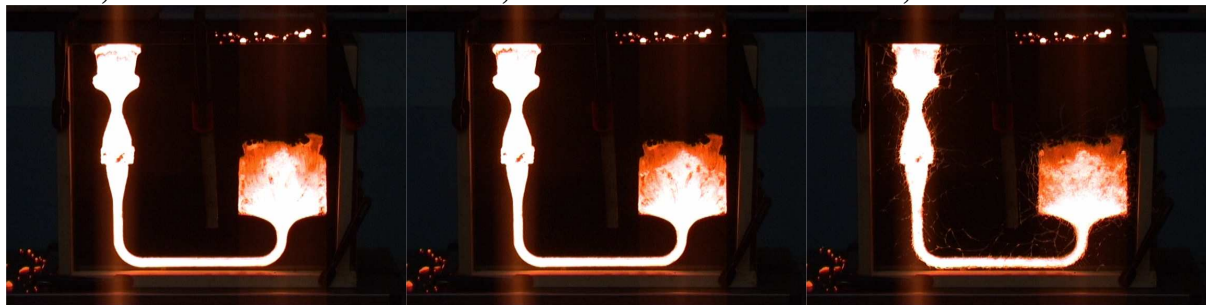
**Time 0,72s**



**Time 0,76s**

**Time 0,80s**

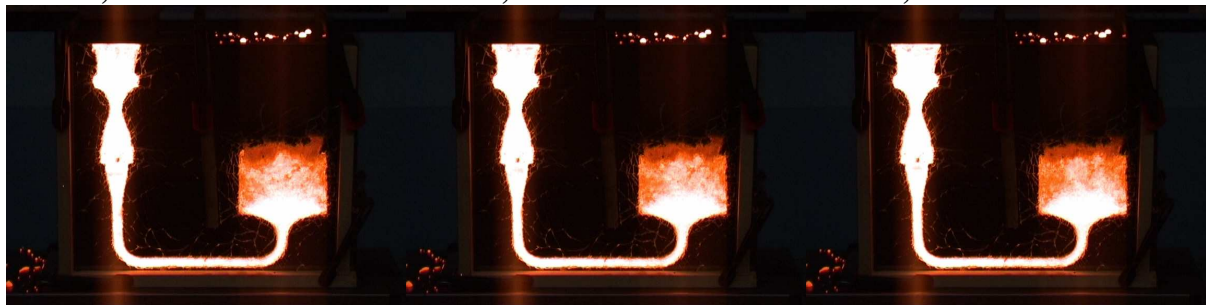
**Time 0,84s**



**Time 0,88s**

**Time 0,92s**

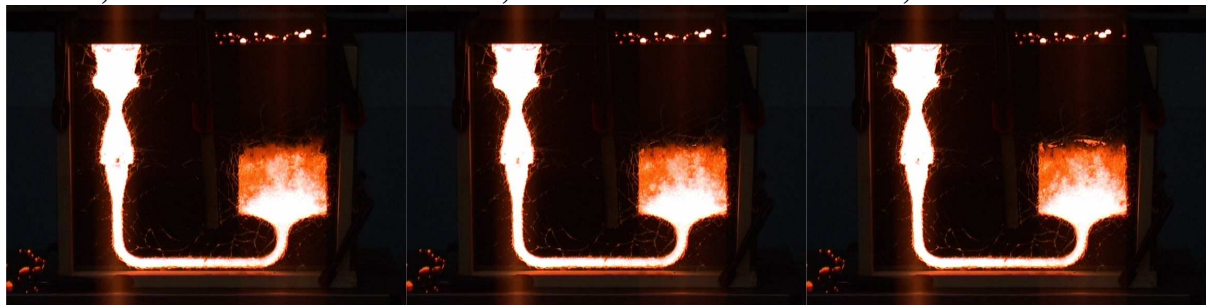
**Time 0,96s**



**Time 1,00s**

**Time 1,04s**

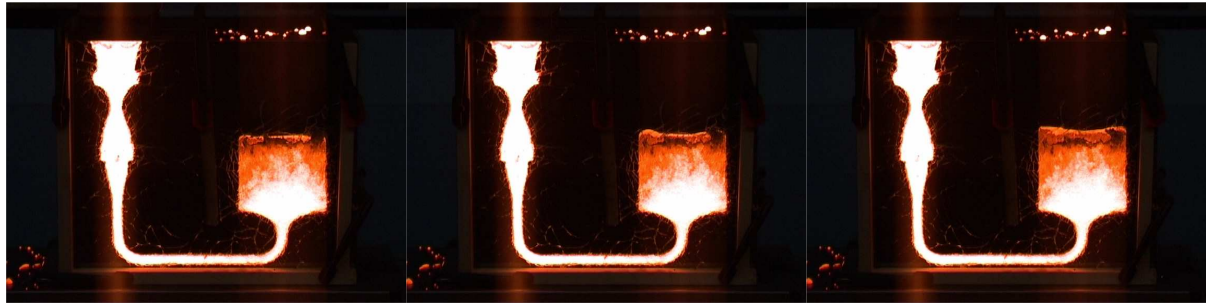
**Time 1,08s**



**Time 1,12s**

**Time 1,16s**

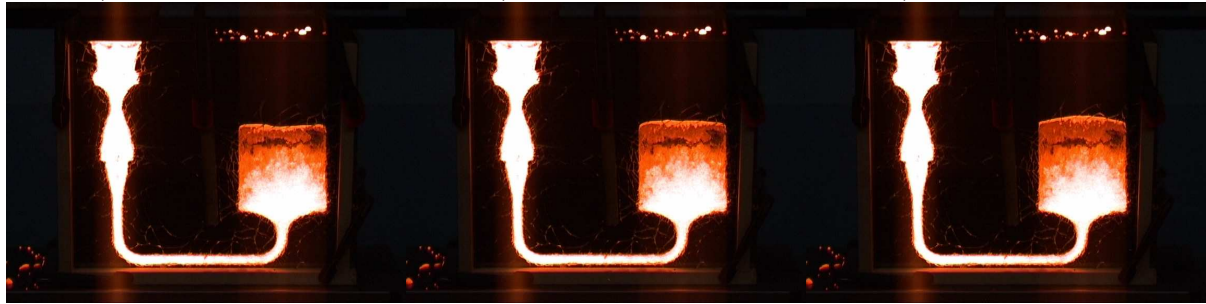
**Time 1,20s**



Time 1,24s

Time 1,28s

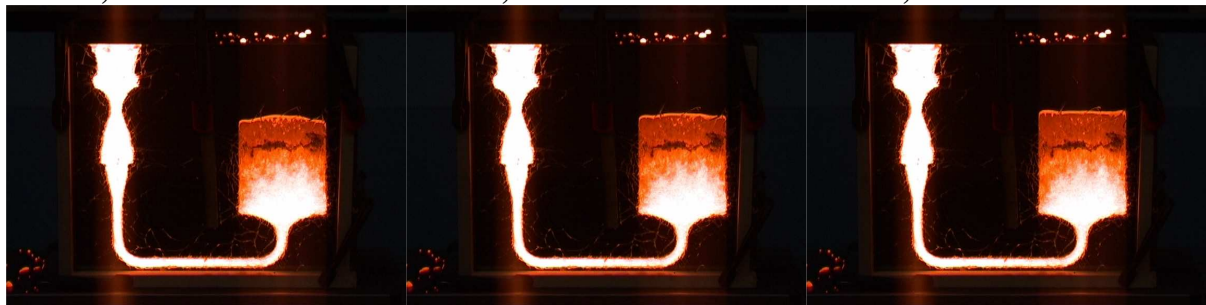
Time 1,32s



Time 1,36s

Time 1,40s

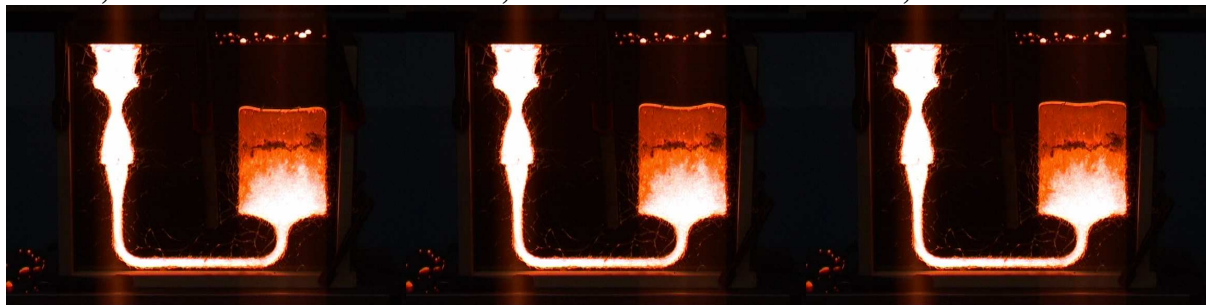
Time 1,44s



Time 1,48s

Time 1,52s

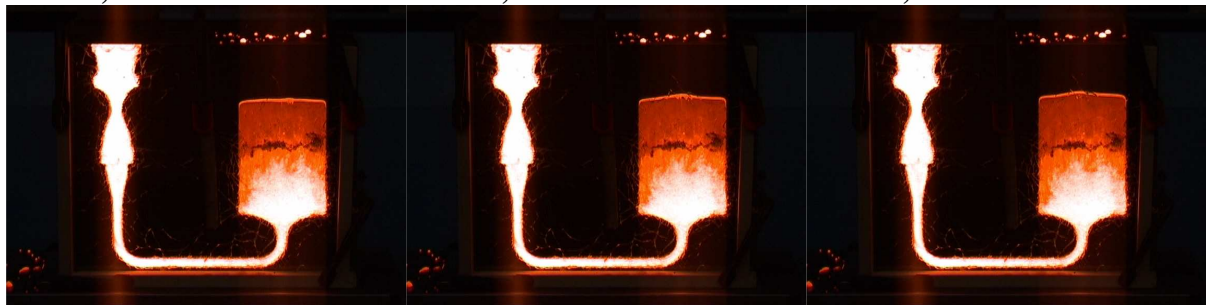
Time 1,56s



Time 1,60s

Time 1,64s

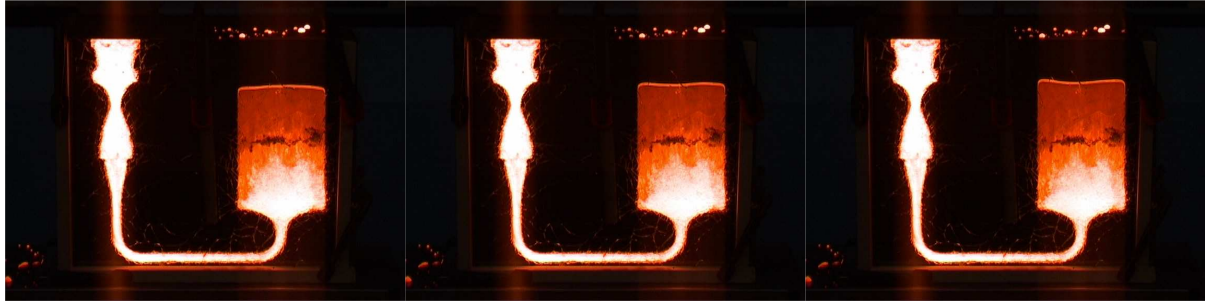
Time 1,68s



Time 1,72s

Time 1,76s

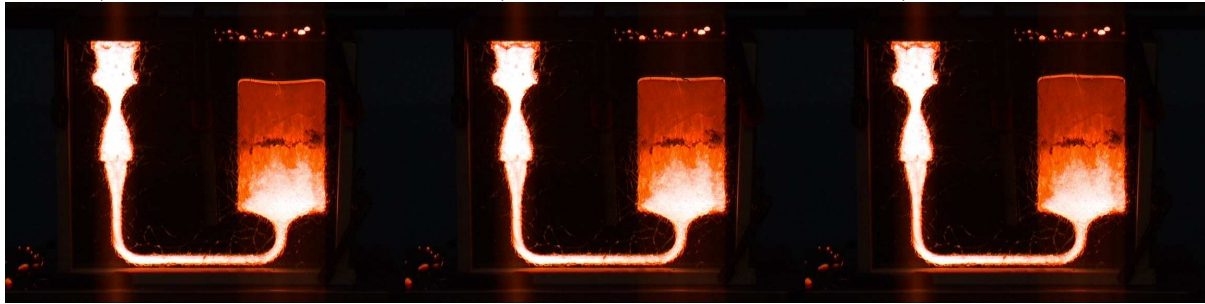
Time 1,80s



**Time 1,84s**

**Time 1,88s**

**Time 1,92s**

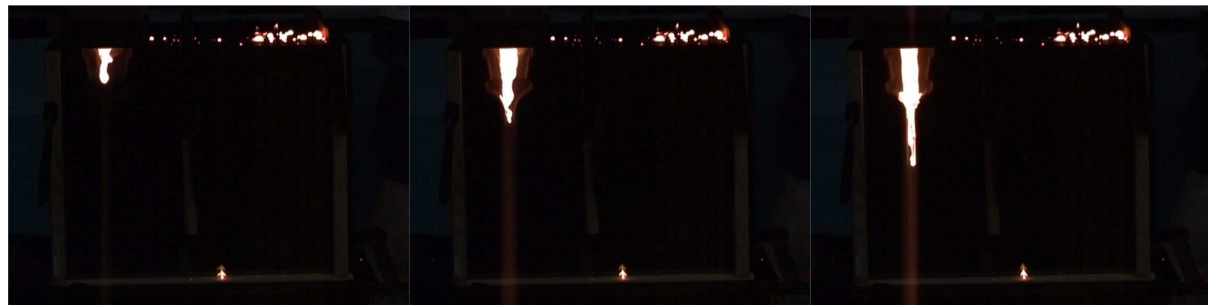


**Time 1,96s**

**Time 2,00s**

**Time 2,04s**

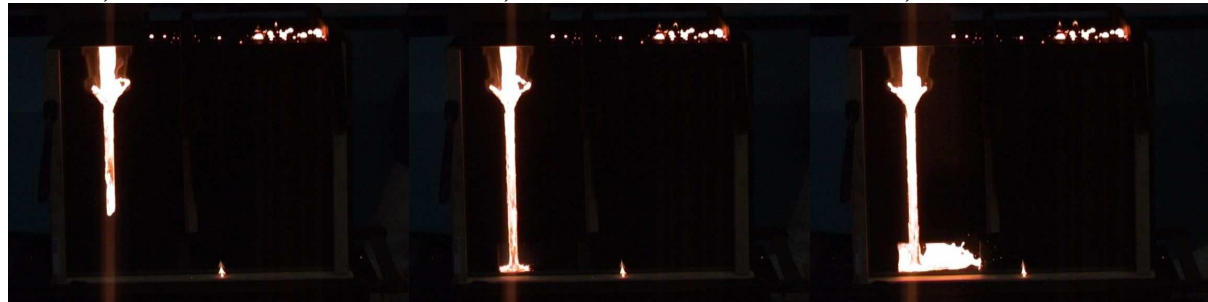
14.4.3 Horizontal (a foam filter is used)



Time 0,04s

Time 0,08s

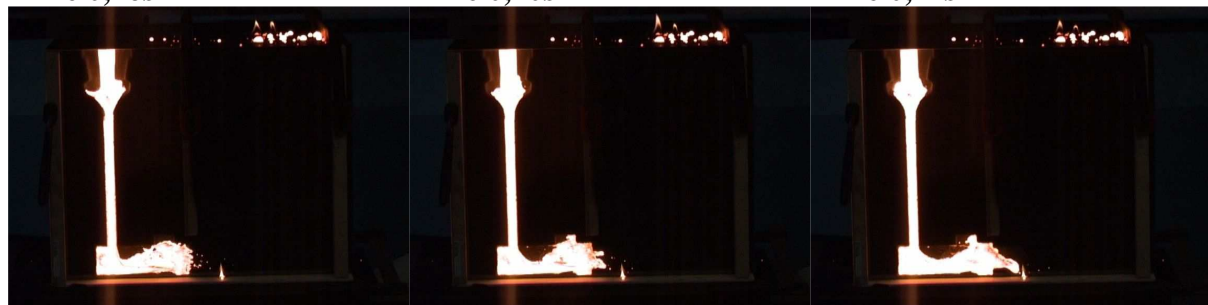
Time 0,12s



Time 0,16s

Time 0,20s

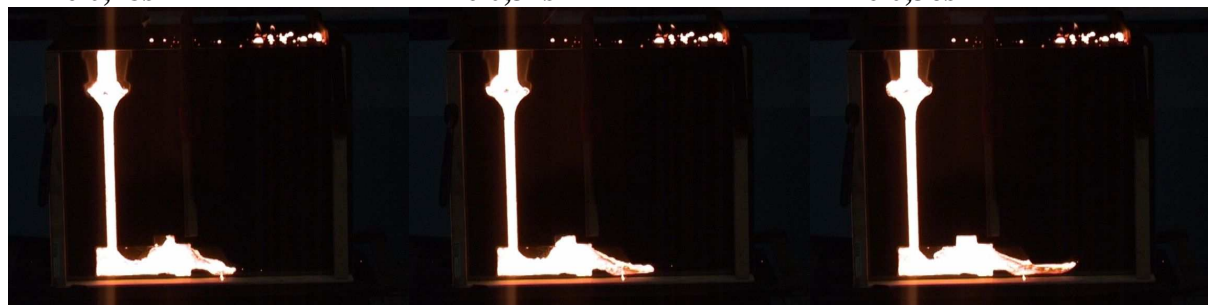
Time 0,24s



Time 0,28s

Time 0,32s

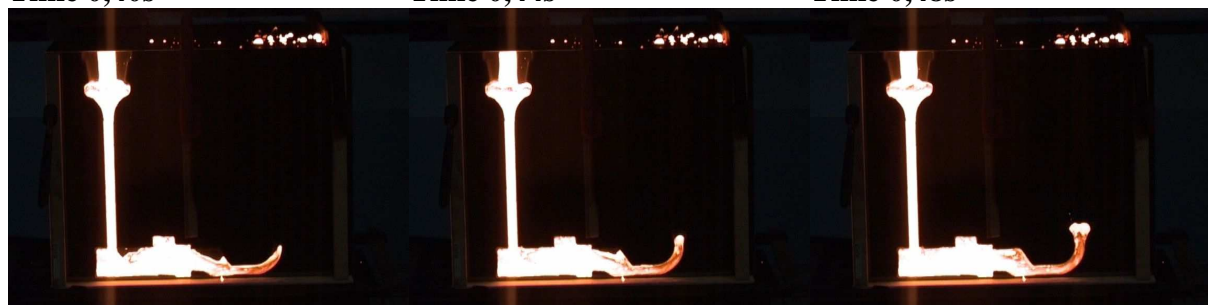
Time 0,36s



Time 0,40s

Time 0,44s

Time 0,48s

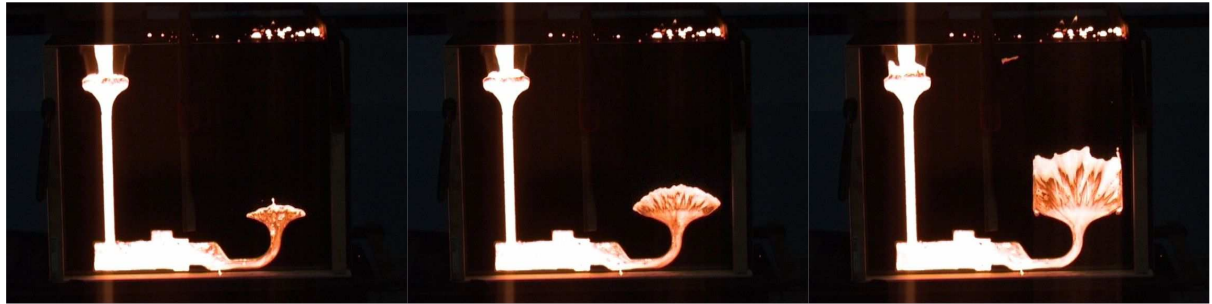


Time 0,52s

Time 0,56s

Time 0,60s

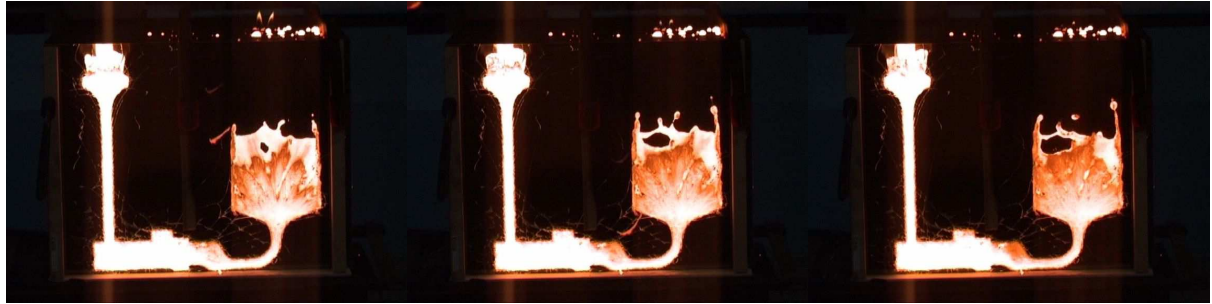




Time 0,64s

Time 0,68s

Time 0,72s



Time 0,76s

Time 0,80s

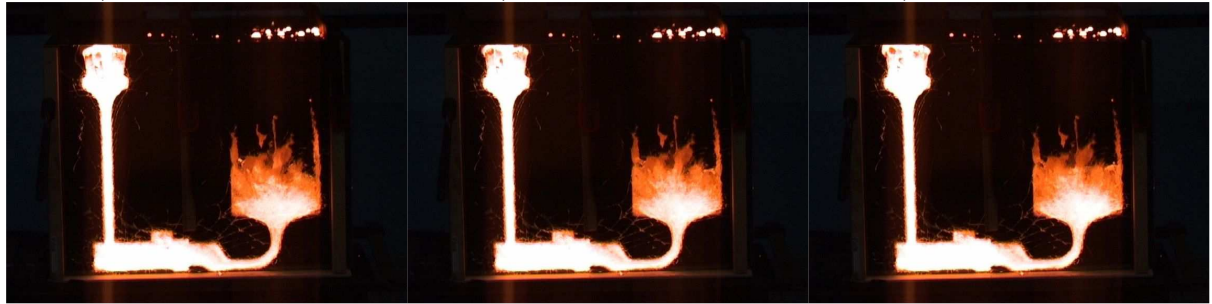
Time 0,84s



Time 0,88s

Time 0,92s

Time 0,96s



Time 1,00s

Time 1,04s

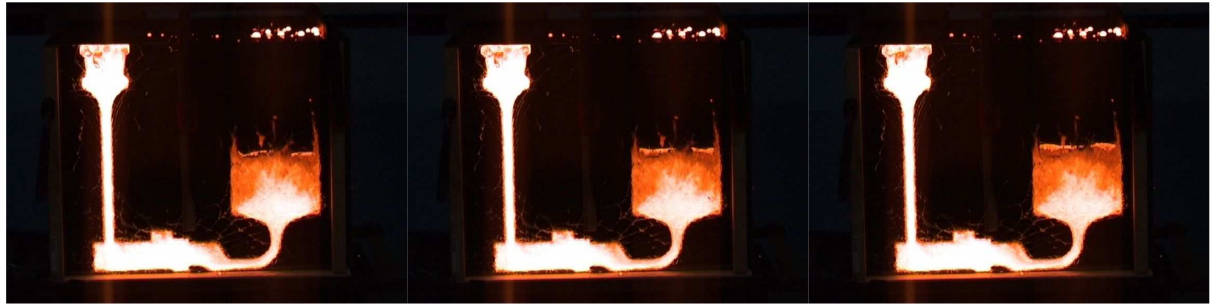
Time 1,08s



Time 1,12s

Time 1,16s

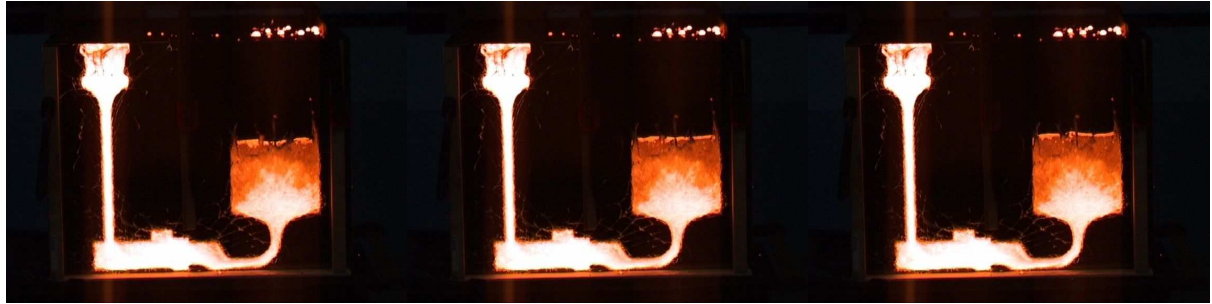
Time 1,20s



Time 1,24s

Time 1,28s

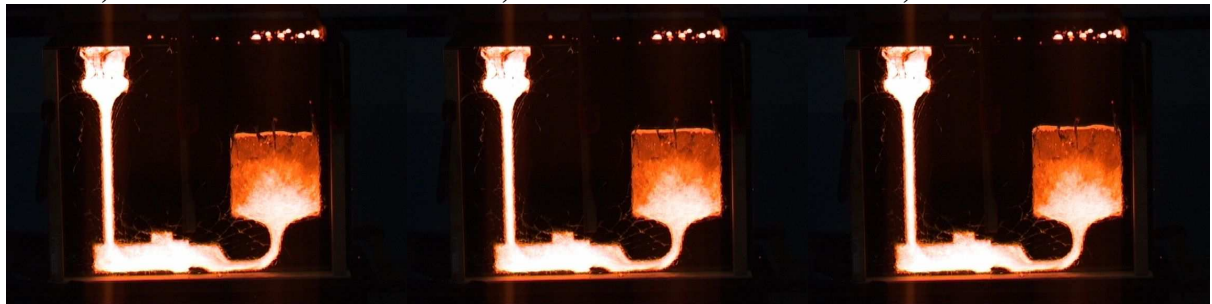
Time 1,32s



Time 1,36s

Time 1,40s

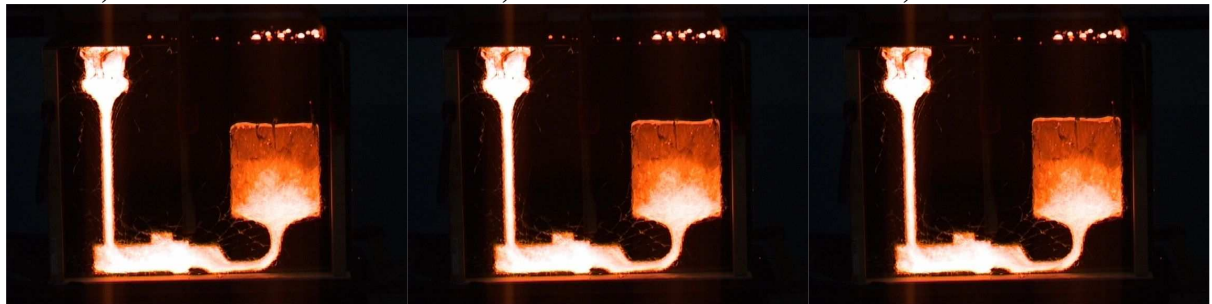
Time 1,44s



Time 1,48s

Time 1,52s

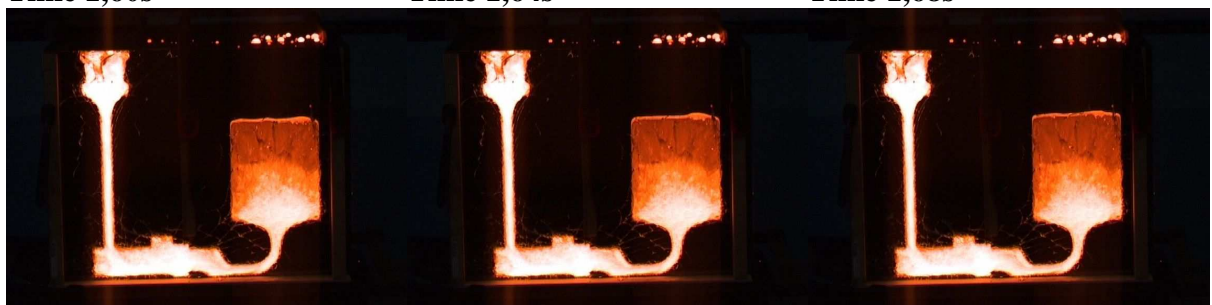
Time 1,56s



Time 1,60s

Time 1,64s

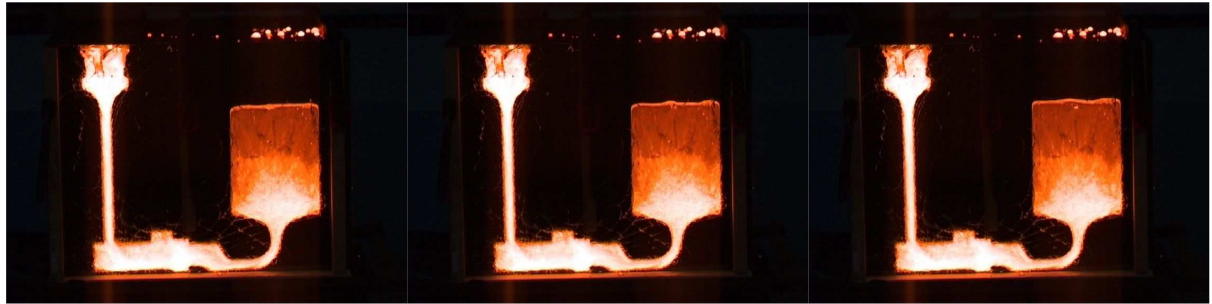
Time 1,68s



Time 1,72s

Time 1,76s

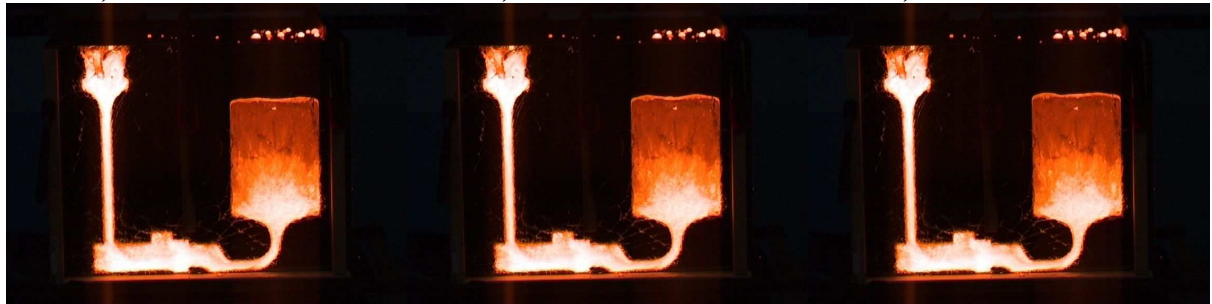
Time 1,80s



**Time 1,84s**

**Time 1,88s**

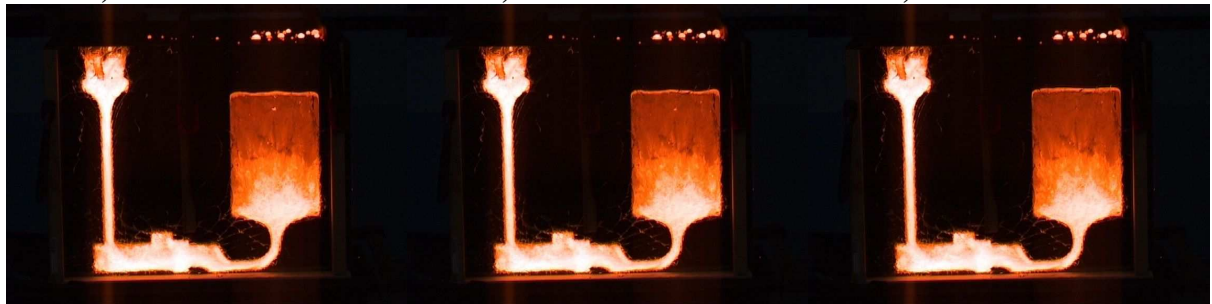
**Time 1,92s**



**Time 1,96s**

**Time 2,00s**

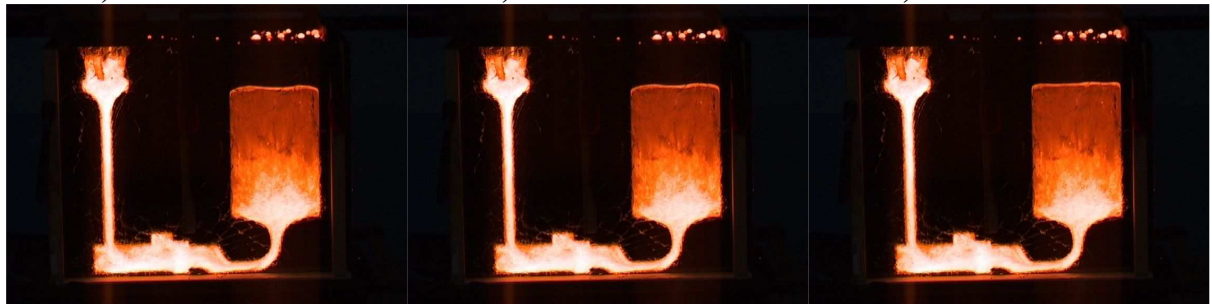
**Time 2,04s**



**Time 2,08s**

**Time 2,12s**

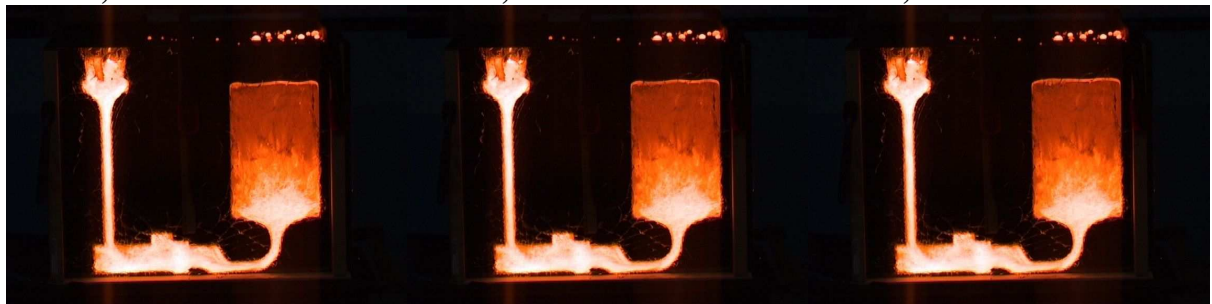
**Time 2,16s**



**Time 2,20s**

**Time 2,24s**

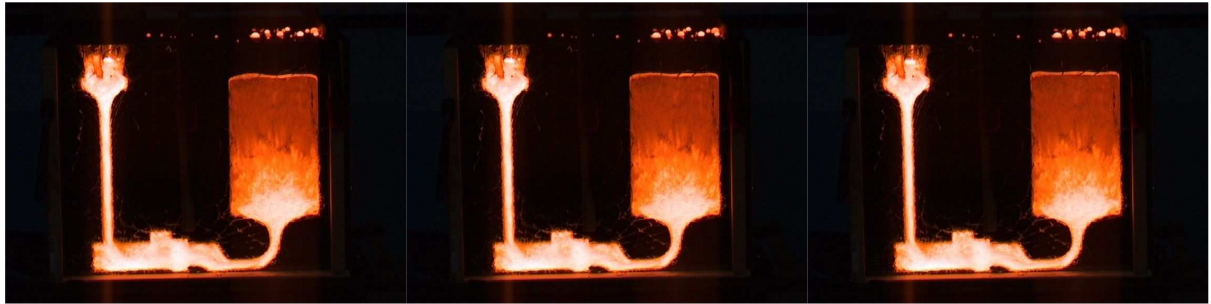
**Time 2,28s**



**Time 2,32s**

**Time 2,36s**

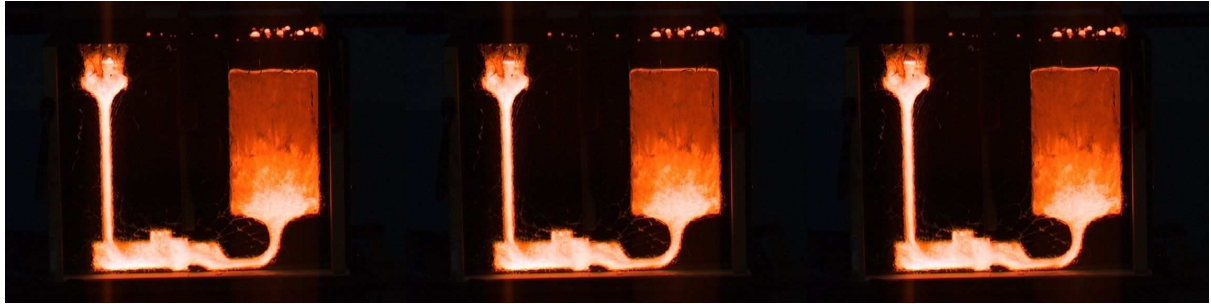
**Time 2,40s**



**Time 2,44s**

**Time 2,48s**

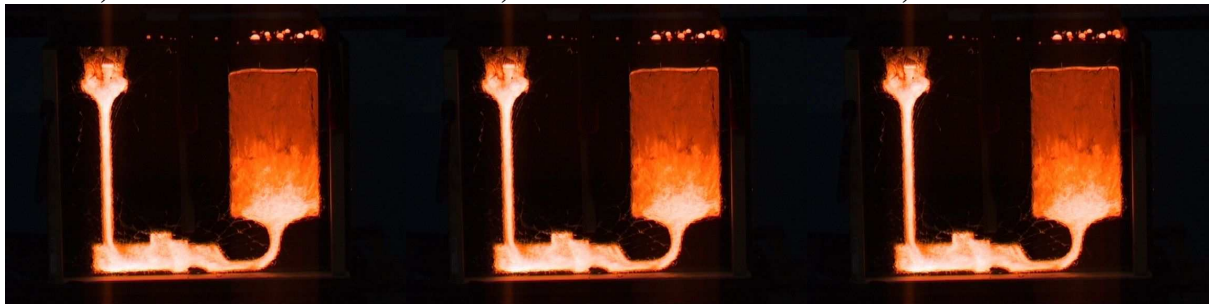
**Time 2,52s**



**Time 2,56s**

**Time 2,60s**

**Time 2,64s**



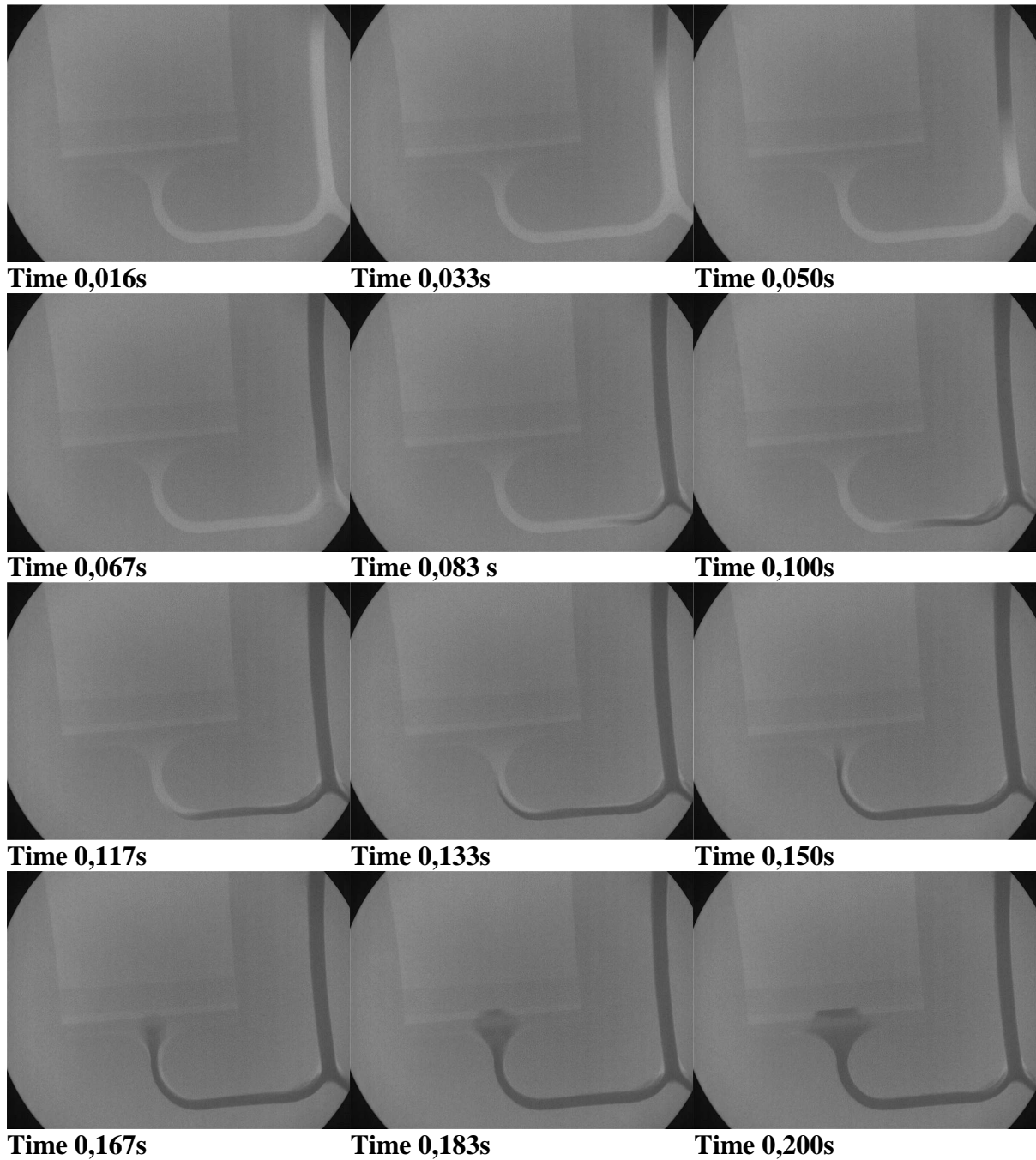
**Time 2,68s**

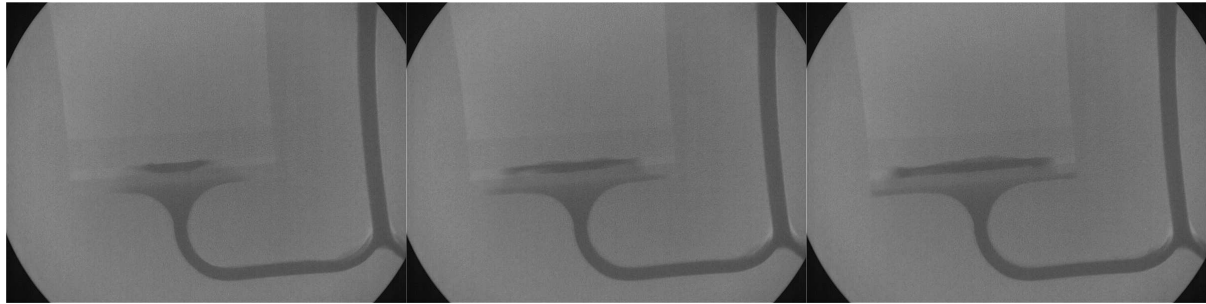
**Time 2,72s**

**Time 2,76s**

## 14.5 Appendix 5 – Experiments using X-Ray

### 14.5.1 Ductile iron 1

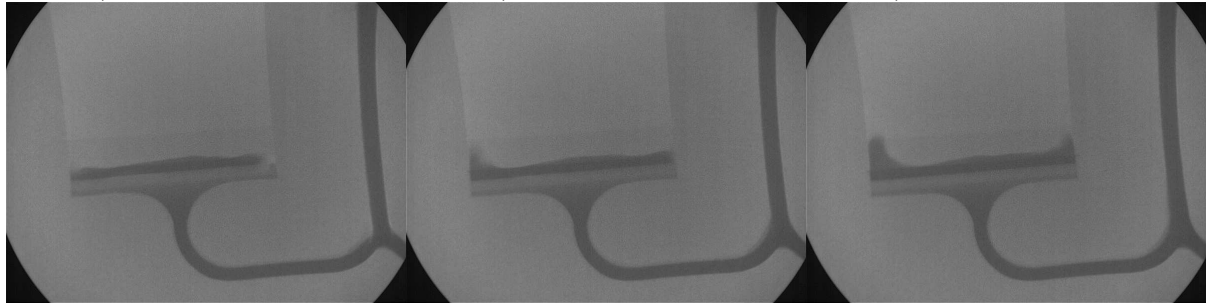




**Time 0,217s**

**Time 0,233s**

**Time0,250s**



**Time 0,267s**

**Time 0,283s**

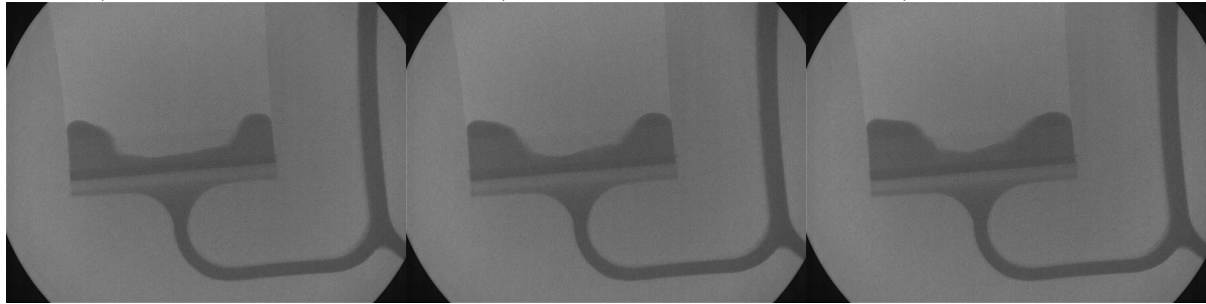
**Time 0,300s**



**Time 0,317s**

**Time 0,333s**

**Time 0,350s**



**Time 0,367s**

**Time 0,383s**

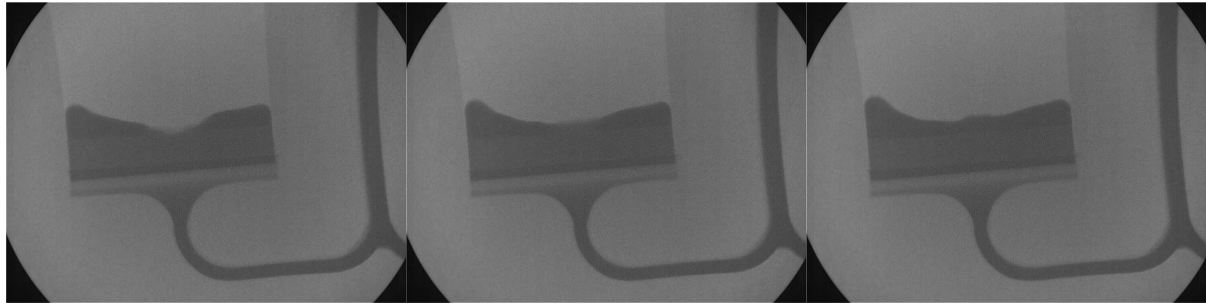
**Time 0,400s**



**Time 0,417s**

**Time 0,433s**

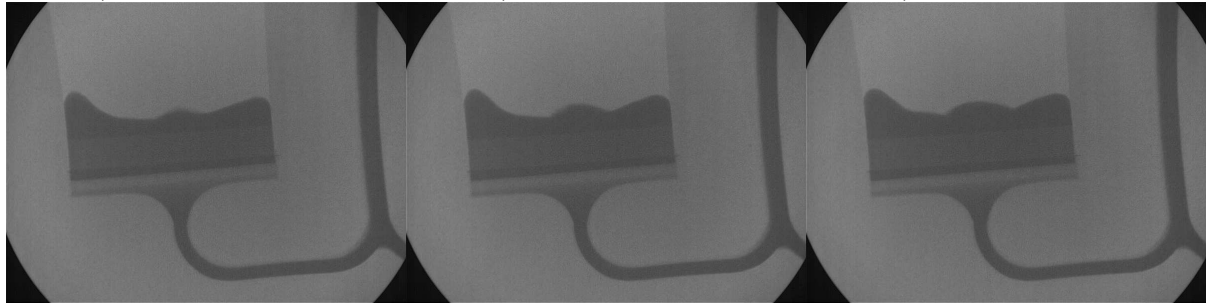
**Time 0,450s**



**Time 0,467s**

**Time 0,483s**

**Time 0,500s**



**Time 0,517s**

**Time 0,533s**

**Time 0,550s**



**Time 0,567s**

**Time 0,583s**

**Time 0,600s**

### 14.5.2 Ductile iron 3



**Time 0,016s**

**Time 0,033s**

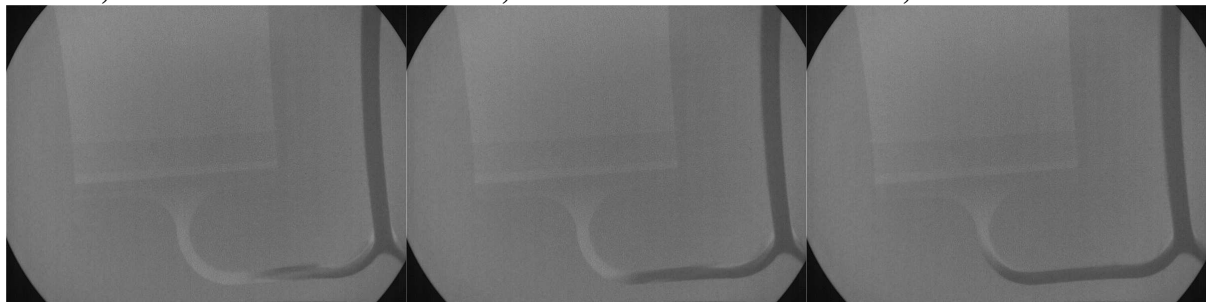
**Time 0,050s**



**Time 0,067s**

**Time 0,083 s**

**Time 0,100s**



**Time 0,117s**

**Time 0,133s**

**Time 0,150s**



**Time 0,167s**

**Time 0,183s**

**Time 0,200s**

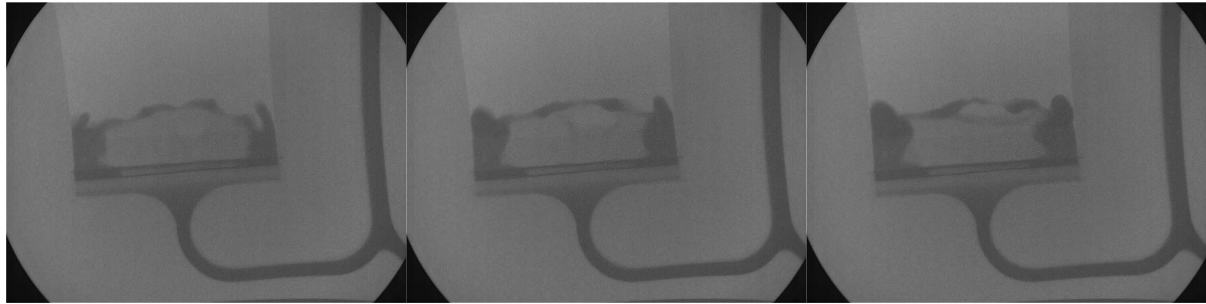


**Time 0,217s**

**Time 0,233s**

**Time0,250s**

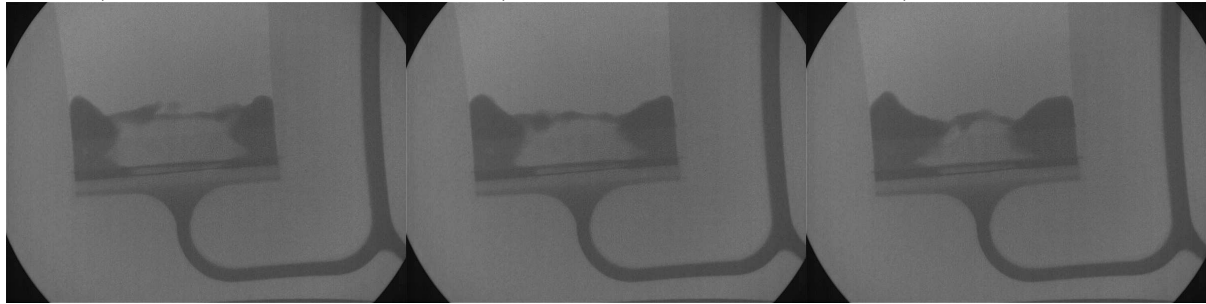




**Time 0,267s**

**Time 0,283s**

**Time 0,300s**



**Time 0,317s**

**Time 0,333s**

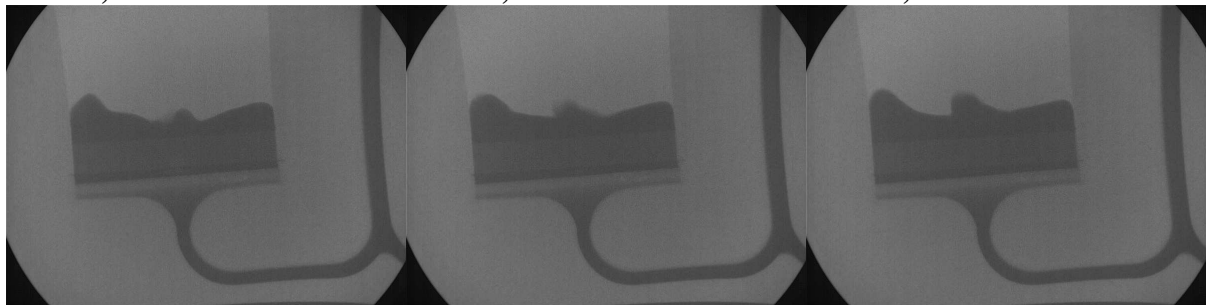
**Time 0,350s**



**Time 0,367s**

**Time 0,383s**

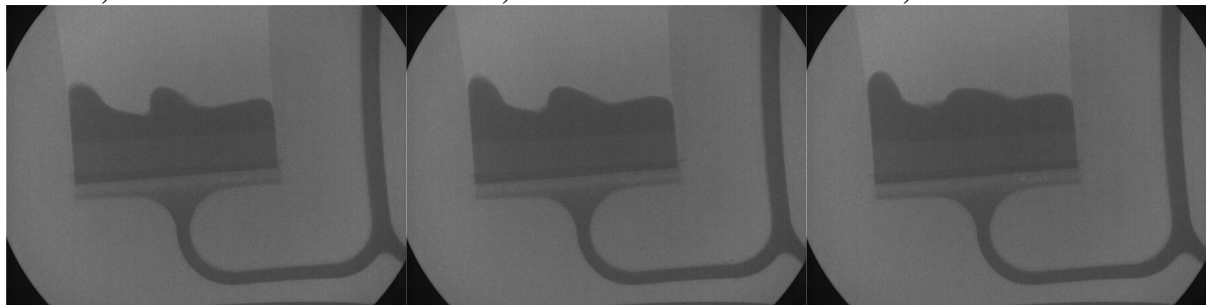
**Time 0,400s**



**Time 0,417s**

**Time 0,433s**

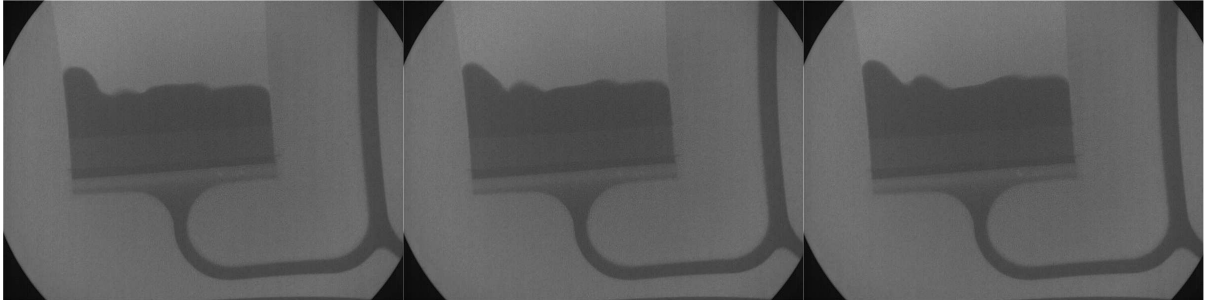
**Time 0,450s**



**Time 0,467s**

**Time 0,483s**

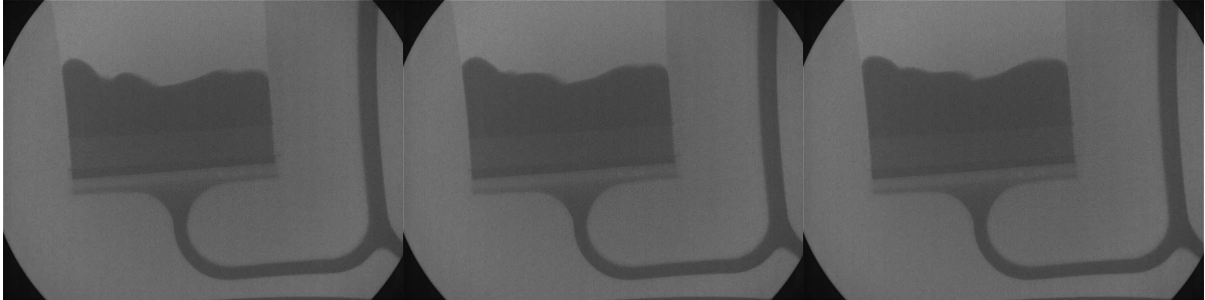
**Time 0,500s**



**Time 0,517s**

**Time 0,533s**

**Time 0,550s**

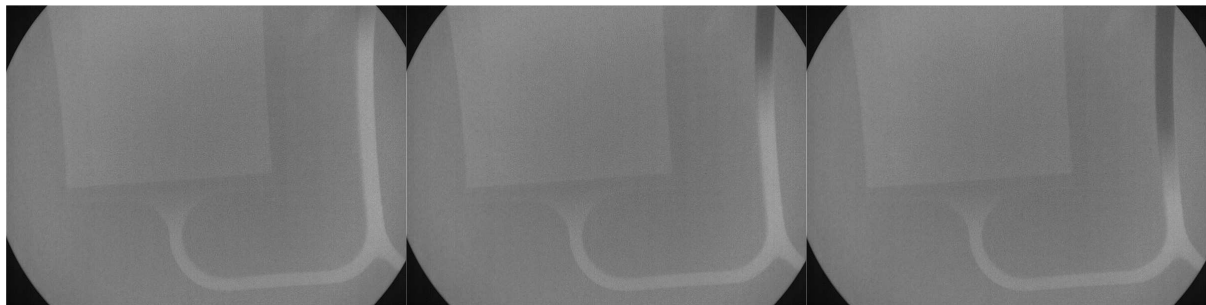


**Time 0,567s**

**Time 0,583s**

**Time 0,600s**

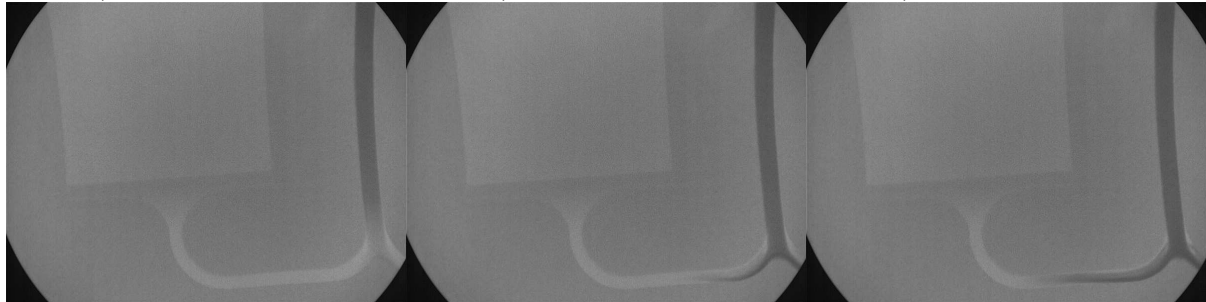
### 14.5.3 Ductile iron 4



**Time 0,016s**

**Time 0,033s**

**Time 0,050s**



**Time 0,067s**

**Time 0,083 s**

**Time 0,100s**



**Time 0,117s**

**Time 0,133s**

**Time 0,150s**



**Time 0,167s**

**Time 0,183s**

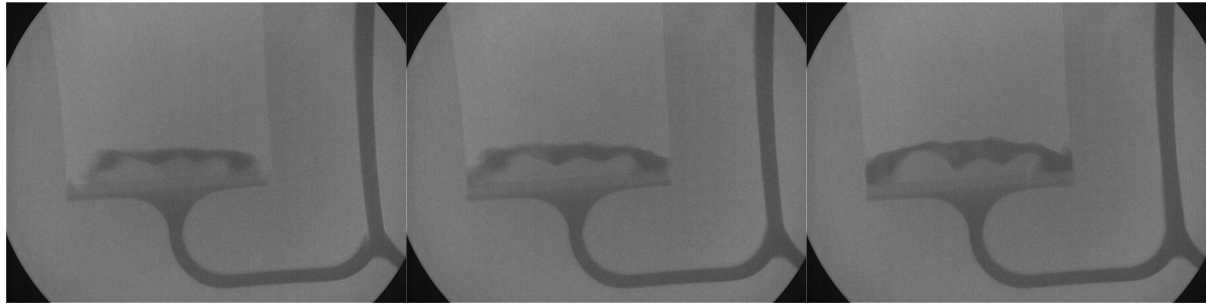
**Time 0,200s**



**Time 0,217s**

**Time 0,233s**

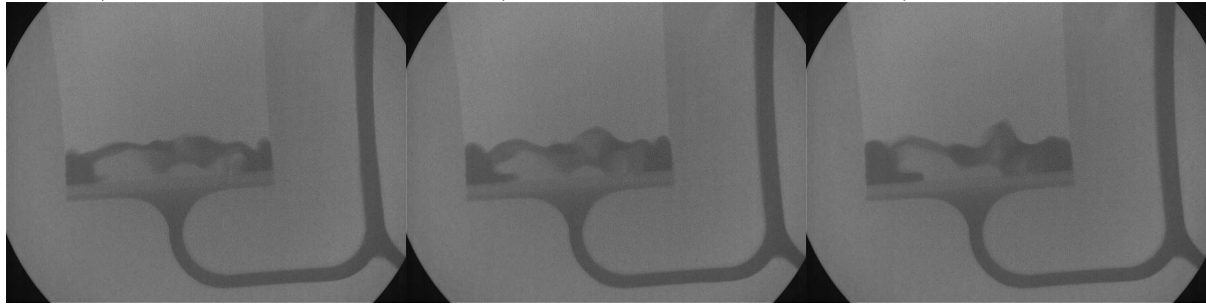
**Time 0,250s**



**Time 0,267s**

**Time 0,283s**

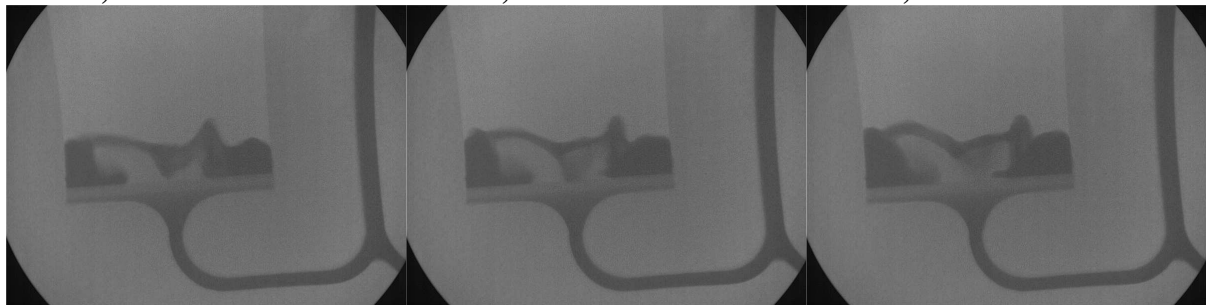
**Time 0,300s**



**Time 0,317s**

**Time 0,333s**

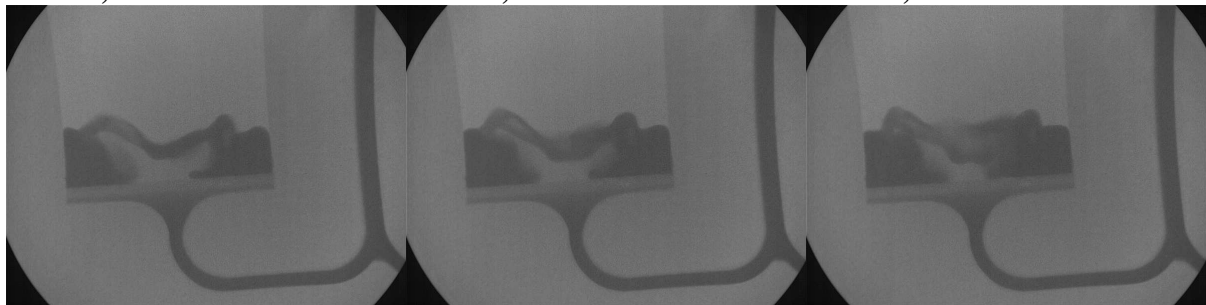
**Time 0,350s**



**Time 0,367s**

**Time 0,383s**

**Time 0,400s**



**Time 0,417s**

**Time 0,433s**

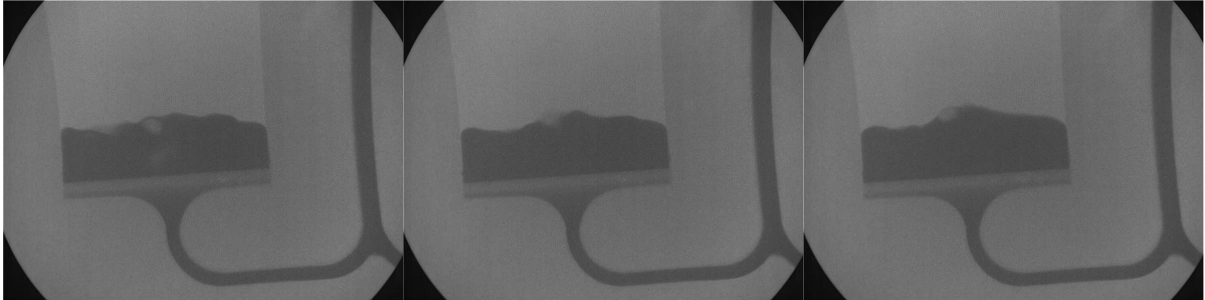
**Time 0,450s**



**Time 0,467s**

**Time 0,483s**

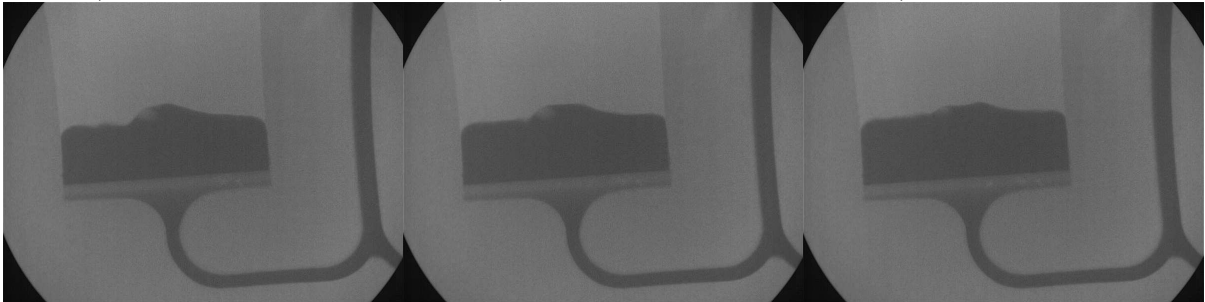
**Time 0,500s**



**Time 0,517s**

**Time 0,533s**

**Time 0,550s**

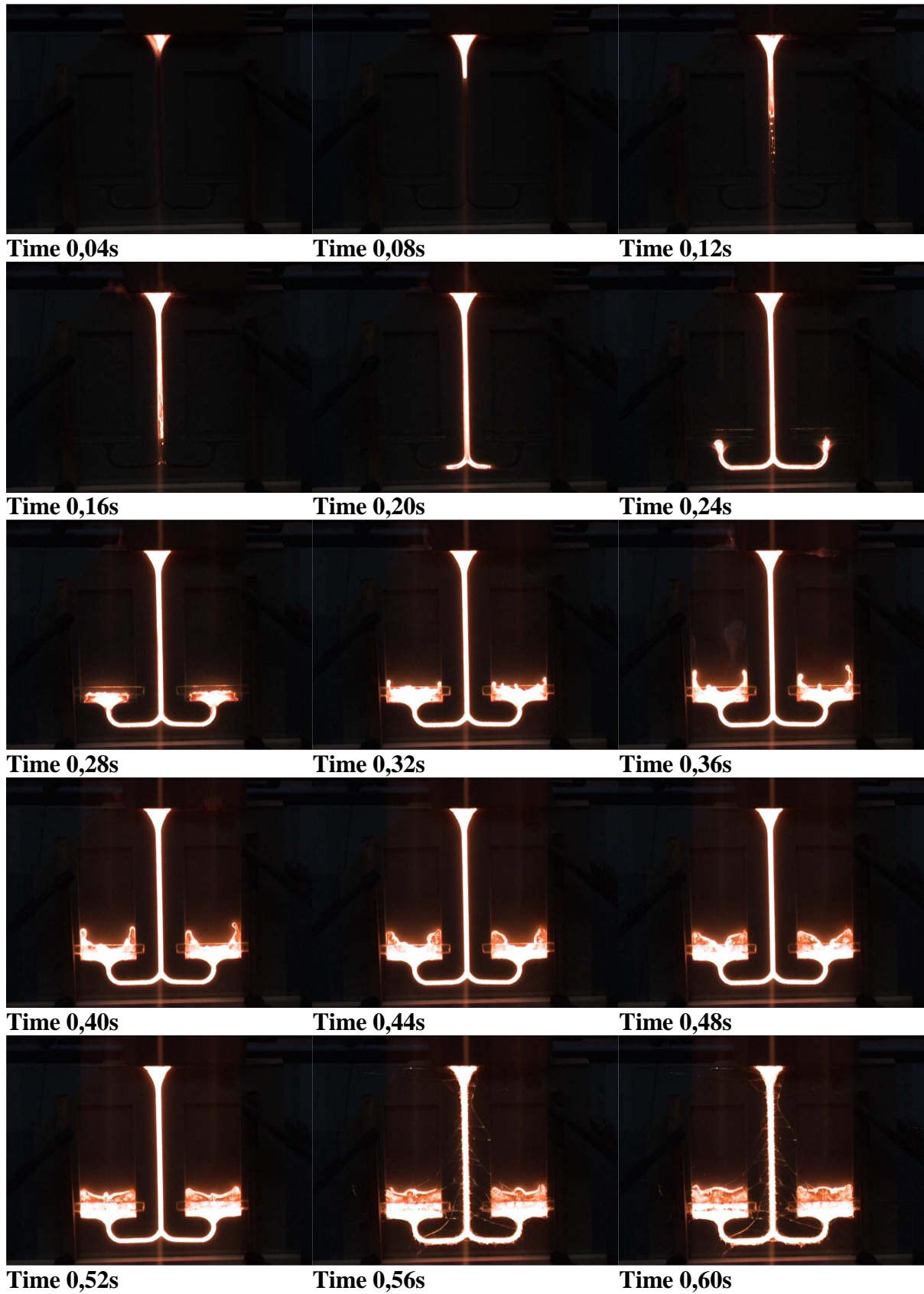


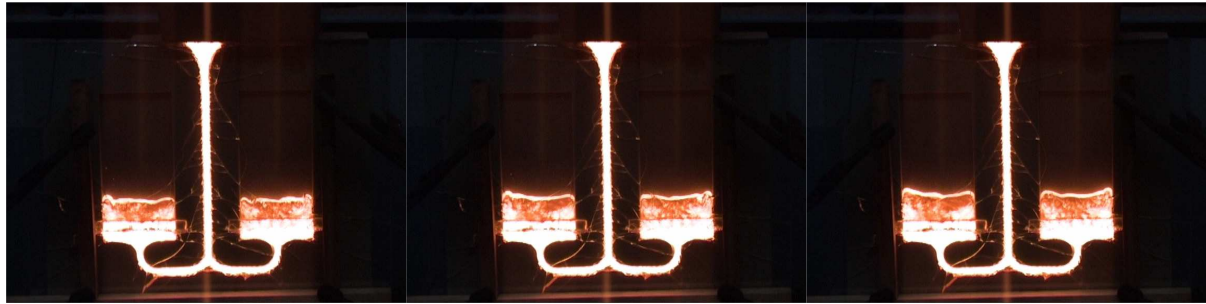
**Time 0,567s**

**Time 0,583s**

**Time 0,600s**

14.5.4 Glass plate experiments – mould 1

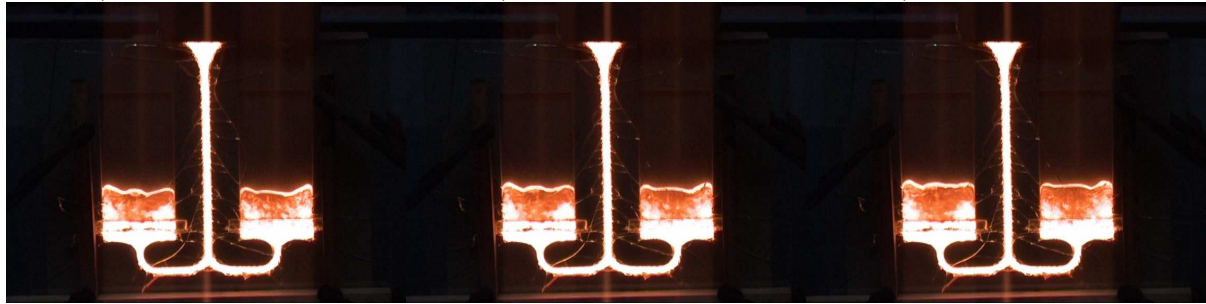




Time 0,64s

Time 0,68s

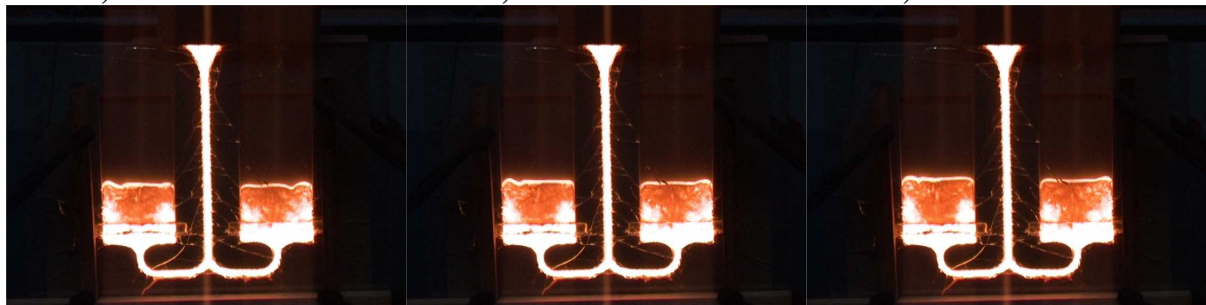
Time 0,72s



Time 0,76s

Time 0,80s

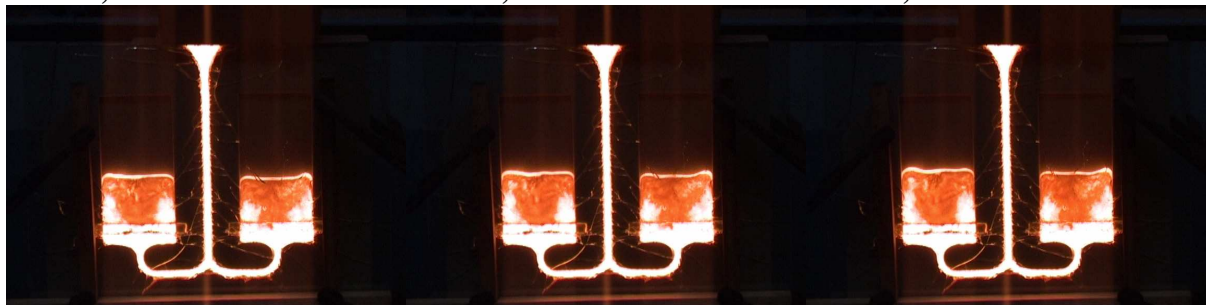
Time 0,84s



Time 0,88s

Time 0,92s

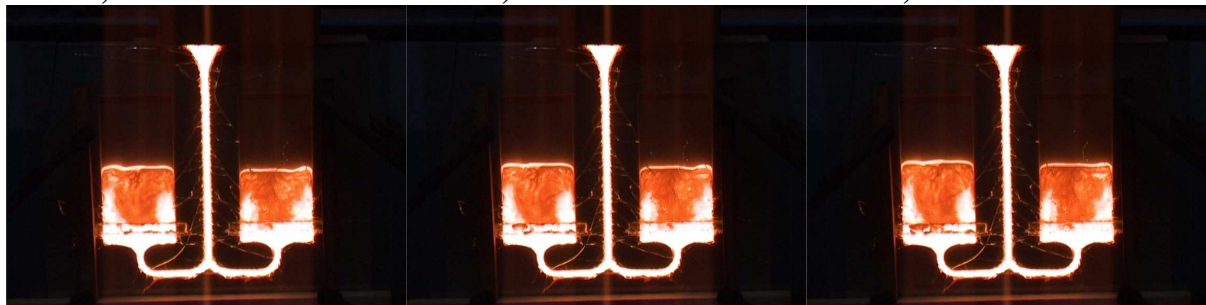
Time 0,96s



Time 1,00s

Time 1,04s

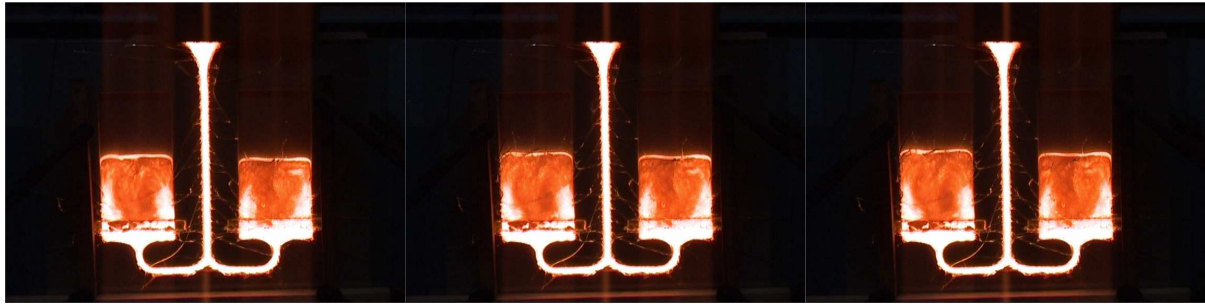
Time 1,08s



Time 1,12s

Time 1,16s

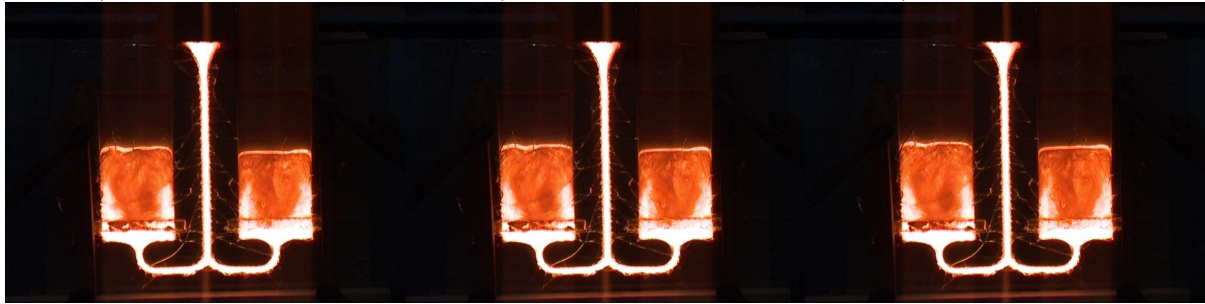
Time 1,20s



**Time 1,24s**

**Time 1,28s**

**Time 1,32s**



**Time 1,36s**

**Time 1,40s**

**Time 1,44s**