

Technical University of Denmark



## Procedure for identifying models for the heat dynamics of buildings

Financed by The Danish Electricity Saving Trust and Vind i Øresund - Interreg 4A

**Bacher, Peder; Madsen, Henrik**

*Publication date:*  
2010

*Document Version*  
Publisher's PDF, also known as Version of record

[Link back to DTU Orbit](#)

*Citation (APA):*

Bacher, P., & Madsen, H. (2010). Procedure for identifying models for the heat dynamics of buildings: Financed by The Danish Electricity Saving Trust and Vind i Øresund - Interreg 4A. Kgs. Lyngby: Technical University of Denmark, DTU Informatics, Building 321. (IMM-Technical report-2010-04).

## DTU Library

Technical Information Center of Denmark

---

### General rights

Copyright and moral rights for the publications made accessible in the public portal are retained by the authors and/or other copyright owners and it is a condition of accessing publications that users recognise and abide by the legal requirements associated with these rights.

- Users may download and print one copy of any publication from the public portal for the purpose of private study or research.
- You may not further distribute the material or use it for any profit-making activity or commercial gain
- You may freely distribute the URL identifying the publication in the public portal

If you believe that this document breaches copyright please contact us providing details, and we will remove access to the work immediately and investigate your claim.

---

# Procedure for identifying models for the heat dynamics of buildings

---

Financed by The Danish Electricity Saving  
Trust and Vind i Øresund - Interreg 4A

Peder Bacher and Henrik Madsen

Informatics and Mathematical Modelling  
Technical University of Denmark  
DK-2800 Kongens Lyngby

March 5, 2010

IMM-Technical Report-2010-04



# Contents

<b>1</b>	<b>Introduction</b>	<b>3</b>
1.1	Background . . . . .	3
1.1.1	FlexHouse . . . . .	4
1.2	Outline . . . . .	5
<b>2</b>	<b>Models for the heat dynamics of a building</b>	<b>6</b>
2.1	Heat dynamics . . . . .	6
2.1.1	Heat Capacity . . . . .	6
2.1.2	Heat Transfer . . . . .	7
2.2	Modelling Approach . . . . .	12
2.3	Grey-box model . . . . .	13
2.3.1	Stochastic linear state space model . . . . .	13
2.3.2	Measurement equation . . . . .	16
2.4	Link to regression models . . . . .	17
<b>3</b>	<b>Parameter estimation</b>	<b>18</b>
3.1	Stochastic linear state space model in discrete time . . . . .	18
3.2	Maximum Likelihood Estimator . . . . .	20
3.3	CTSM - Continuous Time Stochastic Modeling . . . . .	23
3.3.1	Modelling in CTSM . . . . .	23
3.4	Time constants . . . . .	24
3.5	Tests for model selection . . . . .	24
3.5.1	Likelihood ratio tests . . . . .	24
3.5.2	Forward selection . . . . .	25
<b>4</b>	<b>Model identification procedure</b>	<b>26</b>
4.1	Model selection . . . . .	26
4.1.1	Model evaluation . . . . .	28
<b>5</b>	<b>Identifying a model for FlexHouse</b>	<b>29</b>
5.1	Data . . . . .	29

5.2	Applied models . . . . .	30
5.2.1	The full model $TiTmTeThTsAeRia$ . . . . .	32
5.2.2	The simplest model $Ti$ . . . . .	34
5.3	Model identification . . . . .	35
5.3.1	Model selection . . . . .	35
5.3.2	Model evaluation . . . . .	36
<b>6</b>	<b>Conclusion</b>	<b>40</b>
<b>A</b>	<b>Inputs and residuals</b>	<b>41</b>
<b>B</b>	<b>RC-diagrams of applied models</b>	<b>47</b>

# Chapter 1

## Introduction

This report describes a new method for obtaining detailed information about the heat dynamics of a building using frequent reading of the heat consumption. Such a procedure is considered to be of uttermost importance as a key procedure for using readings from smart meters, which is expected to be installed in almost all buildings in the coming years.

### 1.1 Background

Approximately one third of the primary energy production in Denmark is used for heating in buildings. Therefore efforts to accurately describe and improve energy performance of the building mass are very important. In the present study a procedure for identification of suitable models for the heat dynamics of a building is suggested. Such models are essential for different purposes, e.g. control of the indoor climate, accurate description of energy performance of the building, and for forecasting of energy consumption, which will be vital in conditions with increasing fluctuation of the energy supply or varying energy prices. Grey-box models, which are based on prior physical knowledge and data-driven modelling, are applied. A hierarchy of models of increasing complexity is formulated, based on the prior physical knowledge, and a forward selection strategy enables the modeller to iteratively select suitable models of increasing complexity. The performance of the models is measured using likelihood ratio tests, and the models are validated in both a statistical and physical context. A case study is described in which a suitable model is identified for a one-floored 120 m<sup>2</sup> building. The result is a set of different models of increasing complexity, with which building characteristics such as: thermal conductivity, heat capacity of different parts, and effective window area are estimated.

Numerous approaches for modelling the heat dynamics of a building are found in the literature. They can be divided into deterministic methods and stochastic methods. [4] gives an overview of computer-aided building simulation tools presenting the approaches and applications. The present study uses methods developed by [7] and [1] where stochastic differential equations are applied.

### 1.1.1 FlexHouse

FlexHouse is an office building located at Risø DTU, the National Laboratory for Sustainable Energy. The heat supply to FlexHouse is purely electrical. The size of FlexHouse is approximately 120 m<sup>2</sup> divided between eight rooms and a toilet. The rooms have been numbered 0 to 7 to distinguish between them. A layout of FlexHouse can be seen in Figure 1.1 where also the room numbers are shown. Room 1–7 are arranged as small offices, each with

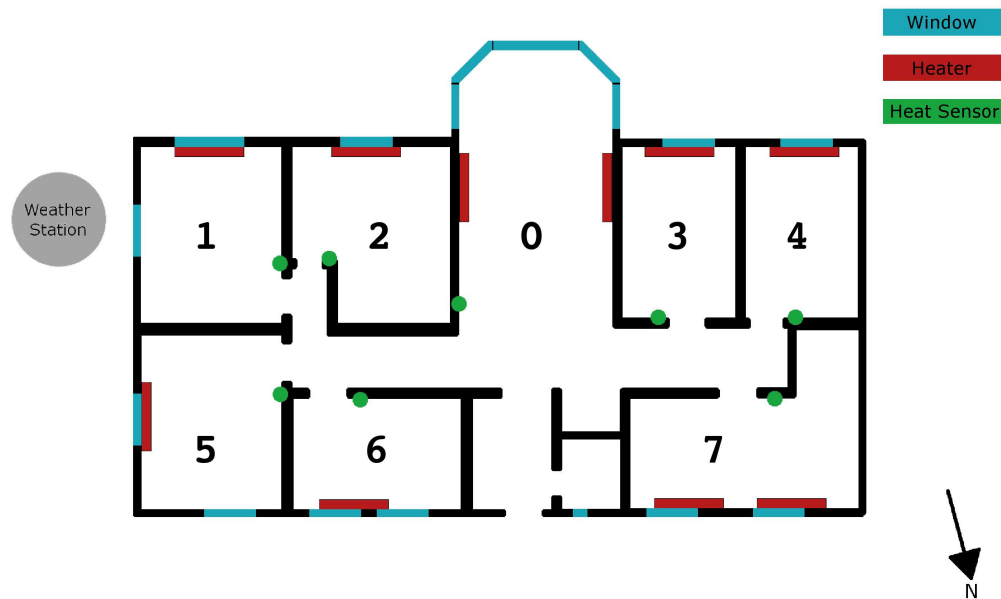

Figure 1.1: FlexHouse layout

a desk, office chair and a computer. The main room, room 0, has been furnished with tables and chairs to accommodate meetings. Moreover room 0 contains a small kitchen with a refrigerator and a coffee machine. The southern wall in the main room is dominated by a large window facade. From the main room access to a toilet is possible, where the water heater is placed. Electrical space heaters are mounted in room 1–6, whereas room 0

and 7 each has two heaters mounted. FlexHouse is build from light building materials. The building envelope consist of an outer layer of wood and an inner layer of plaster, with insolation material in the middle. The house is build upon poles and has an open space of air beneath. For more details of Flexhouse see [10].

## 1.2 Outline

The physical heat transfer theory and modelling approach used in the study are outlined in Chapter 2, followed by a presentation of the statistical techniques used for parameter estimation in Chapter 3. The suggested model identification procedure is described in Chapter 4 and in Chapter 5 the procedure is applied to find a suitable model for the heat dynamics of FlexHouse. Finally the conclusions are drawn in Chapter 6.

# Chapter 2

## Models for the heat dynamics of a building

When modelling the heat dynamics of a building mainly two fundamental aspects are considered. That is, how the heat transfer between the building parts occur and by which entities of the building the model should be divided into. This chapter starts by outlining the theory of heat dynamics and the approximations made in the present models. In the last part of the chapter the grey-box modelling approach is described.

### 2.1 Heat dynamics

Theory of heat dynamics describes the transfer of thermal energy. Thermal energy is energy accumulated in a medium or object as vibration of molecules, and heat transfer is the transfer of thermal energy from an object to its surroundings. According to the second law of thermodynamics the thermal energy transfer is always towards the area with lower energy, i.e. in the direction of the negative temperature gradient. In this way the temperature is always equalized between an object and its surroundings.

#### 2.1.1 Heat Capacity

The capability of a given entity, that is a physical medium or object, e.g. the air in a room or a wall in a building, to accumulate thermal energy is described by its heat capacity  $C$ . When heat  $Q$ , which is the transferred thermal energy is transferred to the object then the temperature  $T$  in the object changes. The heat capacity of the object as a function of the temperature is



defined as

$$C(T) = mc(T) = \frac{dQ}{dT} \quad (2.1)$$

where  $m$  is the mass of the object,  $c(T)$  is the specific heat capacity of the material in the object. The unit of  $C$  is  $[\frac{J}{\circ C}]$ . In the present models  $T$  varies at normal room temperature and the dependency of  $T$  is therefore marginal, and the linear approximation

$$C = \frac{dQ}{dT} \quad (2.2)$$

is used.

### 2.1.2 Heat Transfer

Heat transfer takes place via one of the following fundamental mechanisms

- conduction
- convection
- radiation

Heat transfer is always from areas of higher temperature toward areas of lower temperature and is in general a combination of the three stated mechanisms.

The heat transferred to a system per unit time is the heat flow

$$\frac{dQ}{dt} = C \frac{dT}{dt}. \quad (2.3)$$

where  $t$  is the time. This fundamental relation is utilized in the applied method as the link between a model of heat flows, which are not directly measured, and temperatures which are measured. Furthermore this makes it possible to estimate the heat capacities, since the models are formulated such that they are included as model parameters.

#### Conduction

When a homogeneous medium is conducting thermal energy, the heat conduction per area is proportional to the negative temperature gradient

$$\frac{1}{A} \frac{dQ}{dt} = -\lambda \nabla T = -\lambda \left[ \frac{dT}{dx}; \frac{dT}{dy}; \frac{dT}{dz} \right] \quad (2.4)$$

where  $A$  is the surface area through which the heat flows,  $\lambda$  is the thermal conductivity of the medium. The conductivity is in general dependent on several physical factors, e.g. temperature and moisture, but is in the present models assumed to be constant.

The change in temperature in the medium is described by the diffusion equation. When no heat sinks or sources exist in the conducting medium, the diffusion equation is given by

$$\frac{dT}{dt} = \frac{\lambda}{c\rho} \nabla^2 T = \frac{\lambda}{c\rho} \left( \frac{d^2 T}{dx^2} + \frac{d^2 T}{dy^2} + \frac{d^2 T}{dz^2} \right) \quad (2.5)$$

where  $\rho$  is the density of the medium.

When heat flow through a wall is modelled in the present models, it is approximated to be in the normal direction of the wall only. This reduces the heat conduction per area to

$$\frac{1}{A} \frac{dQ}{dt} = -\lambda \frac{dT}{dx} \quad (2.6)$$

and the change in temperature to

$$\frac{dT}{dt} = \frac{\lambda}{c\rho} \frac{d^2 T}{dx^2}. \quad (2.7)$$

Assuming a stationary condition of temperatures  $T_1$  and  $T_2$ , which are the temperatures on each side of the wall, then

$$\frac{dT}{dt} = 0 \Rightarrow \frac{d^2 T}{dx^2} = 0 \Rightarrow \frac{dT}{dx} = a = \frac{T_2 - T_1}{L} \quad (2.8)$$

where  $a$  is some constant and  $L$  is the thickness of the wall. This is the heat conduction used in the present models and is illustrated in Figure 2.1.

Finally the relation between the temperatures on each side of a wall and the heat flow through the wall can be found from (2.6) and (2.8)

$$\frac{dQ}{dt} = \frac{\lambda A}{L} (T_1 - T_2) \quad (2.9)$$

which is the heat flow from side 1 to side 2. Since the models are formulated such that the heat flows between the entities in model are considered, disregarding the area and thickness of the wall, the R-values are used

$$\frac{dQ}{dt} = \frac{1}{R} (T_1 - T_2) \quad (2.10)$$

where

$$R = \frac{L}{\lambda A} \quad (2.11)$$

is the resistance to heat flow between two entities, and has the unit  $[\frac{^\circ\text{C}}{\text{W}}]$ . Often the UA-values are used and this is simply the inverse of the R-value.

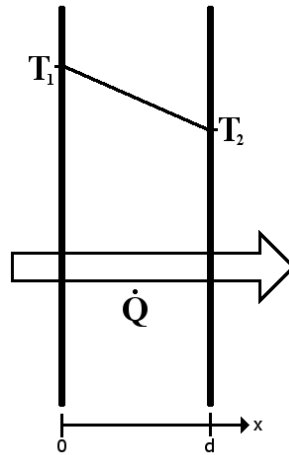

Figure 2.1: Heat transfer through a medium assuming a constant temperature gradient.

## Convection

Convective heat transfer is a mechanism of heat transfer occurring because of bulk motion (observable movement) of fluids. As convection is dependent on the bulk movement of a fluid it can only occur in liquids, gases and multiphase mixtures. Convective heat transfer is split into two categories: natural (or free) convection and forced (or advective) convection, also known as heat advection

Heat transfer by convection is due to a combination of conduction and mass transfer. When a fluid is adjacent to a solid material, heat is transferred between them. If the fluid has a lower temperature than the solid, heat is transferred from the solid to the fluid by conduction. This increases the temperature of the fluid near the wall, which makes the fluid rise and this is replaced by new fluid. The opposite can also happen where warm fluid transfer heat to the solid which sinks down and is replaced by new fluid. The first example is illustrated in Figure 2.2.

As mentioned convection is divided into two categories

- Forced convection
- Free convection

Forced convection is the result of forced fluid flow, e.g. with fans or pumps. In free convection the fluid flows naturally due to density differences in the fluid. For the heat transfer in FlexHouse only free convection will be regarded as a mechanism for exchanging heat between the indoor air and walls.

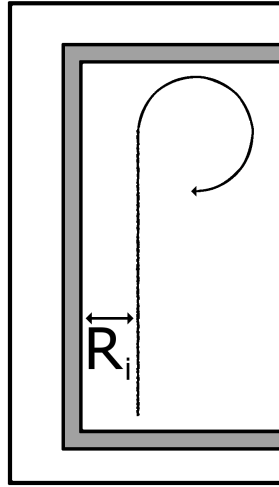

Figure 2.2: Resistance to heat flow by convection

The heat flow by convection is given by Newton's law of cooling

$$\frac{dQ}{dt} = hA(T_s - T_\infty) \quad (2.12)$$

where  $h$  is the convection heat transfer coefficient,  $A$  is the area of the shared surface,  $T_s$  is the temperature of the solid and  $T_\infty$  is the temperature of the fluid far from the solid. A typical value of  $h$  is 2-to-25 W/(m<sup>2</sup> °C), for free convection of gases.

Convection can be modelled similarly to conduction, by setting  $hA = 1/R$ , where  $R$  is the thermal resistance between the air and walls.

### Radiation

Heat exchange by radiation occurs between all objects, having different temperature, that are in optical contact, e.g. radiation is the mode by which heat is transferred from the sun to the earth. The energy is emitted in the form of electromagnetic waves and therefore does not need a medium to propagate in. The energy emitted by a surface is given by

$$\frac{dQ}{dt} = \epsilon\sigma A_s T_s^4 \quad (2.13)$$

where  $\epsilon$  is the emissivity of the surface,  $\sigma = 5.670 \cdot 10^{-8}$  W/(m<sup>2</sup>K<sup>4</sup>) is Stefan-Boltzmann's constant,  $A_s$  is the area of the surface that radiates the energy and  $T_s$  is the surface temperature. In general heat transfer by radiation is very

complex to calculate, since it involves integration over visible surfaces. The heat exchange, however, between a body and a totally surrounding surface can easily be calculated

$$\frac{dQ}{dt} = \epsilon\sigma A_s (T_s^4 - T^4) \quad (2.14)$$

The solar radiation has a big impact on the temperature inside buildings with windows and therefore solar radiation has to be a part of the heat transfer model. The heat flow through a window due to solar radiation can be described by

$$\frac{dQ}{dt} = A_w \Phi_s \quad (2.15)$$

where  $A_w$  is the effective window area and  $\Phi_s$  is the outdoor solar radiation in  $\text{W/m}^2$ . The effective window area is equivalent to the area where the radiation can pass unimpeded.

## Ventilation

Ventilation cause heat transfer due to mass transfer. For most old buildings, like FlexHouse, the house envelope is by no means airtight and the indoor temperature is therefore very dependent on the speed and direction of the wind. The total heat exchange due to ventilation is given by

$$\frac{dQ}{dt} = v c \quad (2.16)$$

where  $v$  is the amount of ventilated air and  $c$  is the specific heat capacity of air.

As with convection, ventilation can either be free or forced. For the heat transfer in FlexHouse only free ventilation is regarded as mode of exchanging heat between the indoor and outdoor air assuming that the air-conditioners are turned off. The amount of free ventilated air is very complex to calculate and depends on many factors, e.g. leakage area, wind speed and direction. Moreover the amount of ventilated air is by no means linear. In previous research conducted in FlexHouse [2] the following relation was proposed for the amount of ventilated air

$$v = \sum \left( A_1 \sqrt{A \Delta T + B V^2} \right) \quad (2.17)$$

where the sum is over all sides of the building,  $A_1$  is the effective leakage area,  $A$  is the stack coefficient,  $B$  is the wind coefficient,  $V$  is the wind component

and  $\Delta T$  is the temperature difference between the indoor and the outdoor temperature.

Due to the age of FlexHouse, the house envelope cannot be assumed to be airtight. [2] estimates the heat loss, in FlexHouse, due to ventilation to be approximately 30% of the total heat loss. This heat loss has to be accounted for in the model of the heat flow. In [2] Equation 2.17 is approximated to be proportional to the temperature difference across the wall, i.e. ventilation loss can be approximated with

$$\frac{dQ}{dt} = k(T_i - T_a) = \frac{1}{R}(T_i - T_a) \quad (2.18)$$

where  $T_i$  is the indoor air temperature,  $T_a$  is the outdoor temperature and  $R$  is the resistance to heat transfer directly to the outside. This approximation holds for low wind speed, but if the wind speed is high ( $> 5 m/s$ ) the heat transfer becomes non-linear.

From this section it is seen that conduction, convection and ventilation, approximately, can be modeled as a resistances against heat transfer. The energy flow into the building due to direct solar radiation can be directly calculated using Equation 2.15 if the outdoor solar radiation is known.

## 2.2 Modelling Approach

When formulating a model for the heat dynamics of a building, three different approaches can be used. The most widespread approach is to formulate a deterministic physical model of the building with which the heat transfer can be simulated in different atmospheric conditions. This approach is called white-box or transparent modelling. A white-box model is continuously formulated. An overview of the vast amount of studies and computer software based on this approach can be found in [4]. Generally the white-box models require detailed building data, such as a 3D model of the dimensions of and the materials in the building.

The simple approach, in terms of physical information needed about the building, is black-box modelling. Here observed data, e.g. the outdoor temperature etc., is used as input to a statistically derived model of some variable e.g. the indoor temperature. A black-box model is discrete and thus contrary to a continuous white-box model. The advantage that little physical information about the building is needed, is also the disadvantage since that less interpretation of the underlying physical parameters can be achieved. Examples of black-box regression models where UA-values of single family houses are estimated can be found in [9]. The link between the grey-box models and the regression models is described in Section 2.4.

The approach used in the present models is grey-box modelling, which is a combination of white-box and black-box modelling. A grey-box model exploits the advantages of these two approaches by both including a continuous physical part and a discrete stochastic part.

## 2.3 Grey-box model

A grey-box model is a model established using a combination of prior physical knowledge and statistics, i.e. information embedded in data. The prior physical knowledge is described by a lumped model of the heat dynamics of the building, which is formulated as a deterministic linear state space model in continuous time. Since the model is lumped a noise term is added to describe the effects which is not described by the deterministic model. Thereby a stochastic linear state space model in continuous time is formed. The information embedded in the observed data is used for parameter estimation, by the formulation of a discrete measurement equation. Furthermore this enables evaluation and tests of the performance of the model. For example the dynamics that is not reflected by the model should optimally be white noise, indicating that the lumped model is consistent with the observed heat dynamics of the building.

### 2.3.1 Stochastic linear state space model

This section describes how the lumped model of the heat dynamics is formulated as a linear state space model, by the use of the heat dynamics theory described in Section 2.1. All the applied models approximate the interior of the building to be one room, and thus that variations of the indoor temperature within the building are close to zero in all areas. The state space model consists of: a set of state variables that describe the state of the system, a set of inputs that affects the system, and a set of continuous differential equations that describe the dynamics of the system. An RC-diagram of a linear model is depicted in Figure 2.3. The model has two heat capacities and two corresponding state variables. The heat flow between building parts are modelled as a combination of a conductive and a convective heat flow, which is simply characterised by a single thermal resistance, i.e. an R-value. Finally the stochastic linear state space model is formed by adding a noise term.

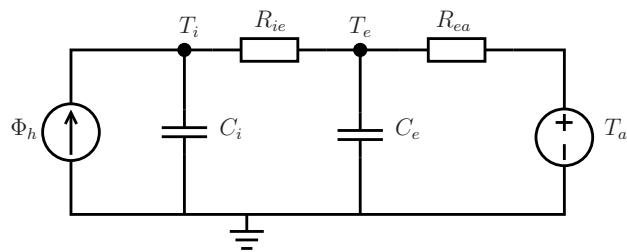
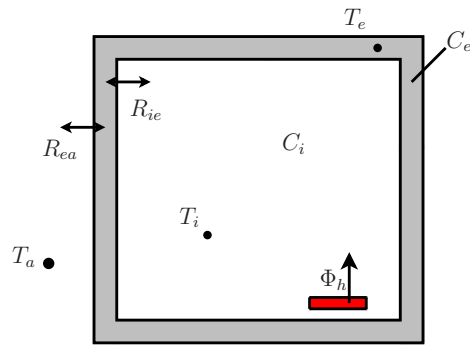

Figure 2.3: An RC-diagram and illustration of a lumped model of the heat dynamics of a building.

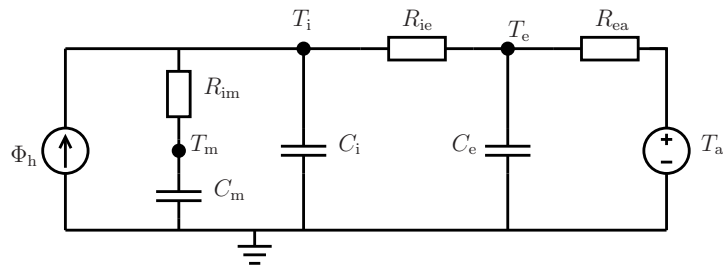

Figure 2.4: A linear model with three state variables.

### State variables

The state variables of the model shown in Figure 2.3 are the indoor temperature  $T_i$  and the building envelope temperature  $T_e$ . Decreasing the number of state variables in the model makes it more lumped. Thus a less lumped model would include more state variables, e.g. the temperature in each room. In the model  $C_i$  represent the total heat capacity both of the indoor air and the interior walls etc. If one more state variable, and corresponding heat ca-



capacity and thermal resistance, is added to the model, as in the model shown in Figure 2.4, then the heat capacity that is represented by  $C_i$  has changed. *Thus it is seen that the physical interpretation of the parameters is dependent on how building is divided into entities in the model.*

## Inputs

Measurements of physical variables are used as input to the state space models. The relevant inputs are those physical variables which affect the state of the system. The input variables of the model showed in Figure 2.3 are the ambient temperature  $T_a$  and the heat from the electrical heaters  $\Phi_h$ .

## Equations describing the heat dynamics

The dynamics of the lumped system is described by first order differential equations which can either be linear or non-linear. The differential equations are based on the heat dynamic theory. In the model showed in Figure 2.3, it is seen that the indoor temperature is dependent on two heat flows. The heat flow from the building envelope to the indoor air is modelled as a combination of a conductive and a convective heat flow. The heat flow from the electrical heater to the indoor air is simply given by  $\Phi_h$ . This leads to the stochastic differential equation describing the first-order dynamics of indoor temperature

$$C_i \frac{dT_i}{dt} = \frac{1}{R_{ie}}(T_e - T_i) + \Phi_h \quad (2.19)$$

where  $R_{ie}$  is the thermal resistance between the building envelope and the indoor air.

The building envelope temperature also dependent on two heat flows, which are both modelled as a combination of a conductive and a convective heat flow. This leads to the first-order dynamics of the building envelope temperature

$$C_e \frac{dT_e}{dt} = \frac{1}{R_{ie}}(T_i - T_e) + \frac{1}{R_{ea}}(T_a - T_e). \quad (2.20)$$

where  $R_{ea}$  is the thermal resistance between the building envelope and the ambient environment.

## Matrix form

The linear state space model depicted in Figure 2.3 on matrix form is

$$\begin{bmatrix} \frac{dT_i}{dt} \\ \frac{dT_e}{dt} \end{bmatrix} = \begin{bmatrix} \frac{-1}{C_i R_{ie}} & \frac{1}{C_i R_{ie}} \\ \frac{1}{C_e R_{ie}} & \frac{-1}{C_e} \left( \frac{1}{R_{ie}} + \frac{1}{R_{ea}} \right) \end{bmatrix} \begin{bmatrix} T_i \\ T_e \end{bmatrix} + \begin{bmatrix} 0 & \frac{1}{C_i} \\ \frac{1}{C_e R_{ie}} & \frac{-1}{C_e} \left( \frac{1}{R_{ie}} + \frac{1}{R_{ea}} \right) \end{bmatrix} \begin{bmatrix} T_a \\ \Phi_h \end{bmatrix} \quad (2.21)$$

and is written as

$$d\mathbf{T} = \mathbf{A}\mathbf{T}dt + \mathbf{B}\mathbf{U}dt \quad (2.22)$$

where  $\mathbf{T} = [T_i, T_e]^T$  is the state vector and  $\mathbf{U} = [T_a, \Phi_h]^T$  is the input vector.  $\mathbf{A}$  defines how the current state affects the dynamics and  $\mathbf{B}$  defines how input enters the system.

## Noise term

To formulate a stochastic state space model, a noise term is added to the state space model. The state space models describes a deterministic system where future states can be precisely predicted if the input and the initial state vector are known. Due to approximations and unknown disturbances in the system this idealization cannot be assumed to be correct. Thus an additive noise term,  $d\boldsymbol{\omega}(t)$  is introduced to form the stochastic linear state space model in continuous time

$$d\mathbf{T} = \mathbf{A}\mathbf{T}dt + \mathbf{B}\mathbf{U}dt + d\boldsymbol{\omega}(t) \quad (2.23)$$

where  $\boldsymbol{\omega}(t)$  is a Wiener process, which is a stochastic process with independent normal distributed increments.

### 2.3.2 Measurement equation

Unfortunately not all states that can be measured, e.g. the building envelope temperature. Therefore a vector of measurable states is introduced. This is defined by the discrete equation

$$\mathbf{T}_r = \mathbf{C}\mathbf{T} + \mathbf{D}\mathbf{U} + \mathbf{e}(t) \quad (2.24)$$

where  $\mathbf{e}(t)$  is the measurement error. It is assumed that  $\mathbf{e}(t)$  is normal distributed white noise with zero mean and variance  $R_e$ . Furthermore it is assumed that  $\mathbf{e}(t)$  and  $\boldsymbol{\omega}(t)$  are mutually uncorrelated.  $\mathbf{C}$  and  $\mathbf{D}$  defines

how the measured states are influenced by the state and input respectively. Considering the example model showed in Figure 2.3 it is seen that the input has no direct influence on the measured air temperature, and therefore  $\mathbf{D} = \mathbf{0}$ .  $\mathbf{C}$  is used to select the states which are measured. For all the models in the present study only the indoor air temperature is measured. The measurement equation for the example model is thus given by

$$T_r = [1 \ 0] \begin{bmatrix} T_i \\ T_e \end{bmatrix} + e(t) = T_i + e(t). \quad (2.25)$$

## 2.4 Link to regression models

The link between the state space models and the regression models considered in [9] for estimation of UA-values, is described in the following. Ignoring the dynamics by setting  $\frac{dT_i}{dt}$  to zero, the simple state space model

$$C \frac{dT_i}{dt} = \frac{1}{R}(T_a - T_i) + \Phi_h \quad (2.26)$$

can be rewritten as

$$\begin{aligned} 0 &= \frac{1}{R}(T_a - T_i) + \Phi_h \Leftrightarrow \\ \Phi_h &= \frac{1}{R}(T_i - T_a). \end{aligned} \quad (2.27)$$

Then since the UA-value

$$\alpha_{UA} = \frac{1}{R} \quad (2.28)$$

and by adding a noise term, the model is

$$\Phi_h = \alpha_{UA}(T_i - T_a) + \epsilon. \quad (2.29)$$

This is the basis for the regression models in [9].

# Chapter 3

## Parameter estimation

In Chapter 2 a simple grey-box model of the heat dynamics of FlexHouse is formulated. Later on more advanced models will be identified using well-known principles from statistical testing. This chapter describes a method for estimation of the parameters in grey-box models, i.e. the thermal resistances and capacities etc. Furthermore it is showed how the time constants are computed and finally statistical tests applied in the model selection strategy is described.

In the first section it is described how the stochastic linear state space model in continuous time is transformed into discrete time. Then the maximum likelihood estimator used to estimate parameters is outlined, followed by a short description of CTSM, which is the software tool used for the calculations. Finally procedures for calculations of time constants and the statistical tests used for the model selection strategy are described.

### 3.1 Stochastic linear state space model in discrete time

The stochastic linear state space model, described in Section 2.3.1, is formulated in continuous time, but the parameter estimation is carried out with statistical techniques applied to data, which is naturally measured in discrete time. The solution to the continuous stochastic differential equation (2.23) is found, such that the state of the system can be calculated for discrete time

steps. The solution to (2.23) can analytically be found to

$$\begin{aligned}\mathbf{T}(t) &= \exp(\mathbf{A}(t - t_0))\mathbf{T}(t_0) + \int_{t_0}^t \exp(\mathbf{A}(t - s))\mathbf{B}\mathbf{U}(s)ds \\ &\quad + \int_{t_0}^t \exp(\mathbf{A}(t - s))d\boldsymbol{\omega}(s)\end{aligned}\quad (3.1)$$

where

$$\exp(\mathbf{A}) = \sum_{k=0}^{\infty} \frac{1}{k!} \mathbf{A}^k = \mathbf{I} + \mathbf{A} + \frac{1}{2}\mathbf{A}^2 + \dots \quad (3.2)$$

See [5] for more details. Given the state vector at time  $t$ ,  $\mathbf{T}(t)$ , the new state vector at time  $t + \tau$  is given by

$$\begin{aligned}\mathbf{T}(t + \tau) &= \exp(\mathbf{A}(t + \tau - t))\mathbf{T}(t) + \int_t^{t+\tau} \exp(\mathbf{A}(t + \tau - s))\mathbf{B}\mathbf{U}(s)ds \\ &\quad + \int_t^{t+\tau} \exp(\mathbf{A}(t + \tau - s))d\boldsymbol{\omega}(s)\end{aligned}\quad (3.3)$$

Assuming that the input,  $\mathbf{U}(t)$ , is constant in the sample interval  $[t; t + \tau[$ , (3.3) can be reformulated to

$$\begin{aligned}\mathbf{T}(t + \tau) &= \exp(\mathbf{A}\tau)\mathbf{T}(t) - \int_{\tau}^0 \exp(\mathbf{A}r)\mathbf{B}dr\mathbf{U}(t) \\ &\quad + \int_t^{t+\tau} \exp(\mathbf{A}(t + \tau - s))d\boldsymbol{\omega}(s) \\ &= \exp(\mathbf{A}\tau)\mathbf{T}(t) + \int_0^{\tau} \exp(\mathbf{A}r)\mathbf{B}dr\mathbf{U}(t) \\ &\quad + \int_t^{t+\tau} \exp(\mathbf{A}(t + \tau - s))d\boldsymbol{\omega}(s)\end{aligned}\quad (3.4)$$

where the substitution  $r = t + \tau - s$  has been used. Defining

$$\begin{aligned}\boldsymbol{\Phi}(\tau) &= \exp(\mathbf{A}\tau) \\ \boldsymbol{\Gamma}(\tau) &= \int_0^{\tau} \exp(\mathbf{A}r)\mathbf{B}dr \\ \mathbf{v}(t; \tau) &= \int_t^{t+\tau} \exp(\mathbf{A}(t + \tau - s))d\boldsymbol{\omega}(s)\end{aligned}\quad (3.5)$$

Then (3.4) can be written as

$$\mathbf{T}(t + \tau) = \boldsymbol{\Phi}(\tau)\mathbf{T}(t) + \boldsymbol{\Gamma}(\tau)\mathbf{U}(t) + \mathbf{v}(t, \tau) \quad (3.6)$$

Assuming that  $\boldsymbol{\omega}(t)$  is a Wiener process,  $\mathbf{v}(t; \tau)$  becomes normally distributed white noise with zero mean and covariance

$$\begin{aligned} \mathbf{R}_1(\tau) &= E[\mathbf{v}(t; \tau)\mathbf{v}(t; \tau)^T] = \int_0^\tau \boldsymbol{\Phi}(s)\mathbf{R}_1\boldsymbol{\Phi}(s)^T ds \\ &= \begin{bmatrix} R_{11} & 0 & 0 \\ 0 & R_{22} & 0 \\ 0 & 0 & R_{33} \end{bmatrix} \end{aligned} \quad (3.7)$$

If the sampling time is constant, the time scale in (3.6) can be transformed such that the sampling time is equal to one time unit, i.e.

$$\mathbf{T}(t+1) = \boldsymbol{\Phi}\mathbf{T}(t) + \boldsymbol{\Gamma}\mathbf{U}(t) + \mathbf{v}(t) \quad (3.8)$$

This formulation can be used for estimation of the unknown parameters in (2.23) without losing the physical interpretation of the parameters.

## 3.2 Maximum Likelihood Estimator

In Section 3.1, it was found that the stochastic linear state space model in continuous time could be formulated as a difference equation in discrete time

$$\mathbf{T}(t+1) = \boldsymbol{\Phi}\mathbf{T}(t) + \boldsymbol{\Gamma}\mathbf{U}(t) + \mathbf{v}(t) \quad t \in 0, 1, 2, \dots, N \quad (3.9)$$

when the sampling time is constant, that is, equally spaced observations. In (3.9)  $t$  corresponds to the measurement at time index  $t$ , i.e. the  $t$ 'th measurement. The likelihood function can be used to estimate the unknown parameters in  $\boldsymbol{\Phi}$  and  $\boldsymbol{\Gamma}$ , where the most likely estimator is given by

$$\hat{\boldsymbol{\theta}} = \arg \max_{\boldsymbol{\theta}} \{L(\boldsymbol{\theta}; \mathbf{T}_r(N))\} \quad (3.10)$$

where  $L$ , the likelihood function, is the joint probability distribution function of all the observations.

Let  $\mathbf{T}_r(t) = [T_r(t), T_r(t-1), \dots, T_r(0)]$  be a vector containing all observations up to and including  $t$  and  $\boldsymbol{\theta}$  be a vector containing all the unknown parameters in  $\boldsymbol{\Phi}$  and  $\boldsymbol{\Gamma}$ , including  $R_{11}$ ,  $R_{22}$ ,  $R_{33}$  from (3.7) and the measurement error,  $R_e$ . Then the likelihood function can be formulated as the joint probability distribution when  $\boldsymbol{\theta}$  is given

$$\begin{aligned} L(\boldsymbol{\theta}; \mathbf{T}_r(N)) &= p(\mathbf{T}_r(N)|\boldsymbol{\theta}) \\ &= p(\mathbf{T}_r(N)|\mathbf{T}_r(N-1), \boldsymbol{\theta})p(\mathbf{T}_r(N-1)|\boldsymbol{\theta}) \\ &= \left( \prod_{t=1}^N p(\mathbf{T}_r(t)|\mathbf{T}_r(t-1), \boldsymbol{\theta}) \right) p(\mathbf{T}_r(0)|\boldsymbol{\theta}) \end{aligned} \quad (3.11)$$

where the rule  $P(A \cap B) = P(A|B)P(B)$  has been used  $N$ -times to form the likelihood function as a product of conditional densities. Since both  $\mathbf{v}(t)$  and  $e(t)$ , in (3.8) and (2.24), are assumed to be normally distributed, the conditional density function is also normally distributed, and is thus fully characterized by its mean and variance. The multivariate normal distribution is given by

$$f(\mathbf{x}) = \frac{1}{(2\pi)^{n/2} \sqrt{\det \boldsymbol{\Sigma}}} \exp \left( -\frac{1}{2} (\mathbf{x} - \boldsymbol{\mu})^T \boldsymbol{\Sigma}^{-1} (\mathbf{x} - \boldsymbol{\mu}) \right) \quad (3.12)$$

where  $\boldsymbol{\Sigma} > \mathbf{0}$  is the covariance and  $\boldsymbol{\mu}$  is the mean. Introducing the conditional mean

$$\hat{\mathbf{T}}(t|t-1) = E[\mathbf{T}_r(t) | \mathbf{T}_r(t-1), \boldsymbol{\theta}] \quad (3.13)$$

the conditional variance

$$\mathbf{R}(t|t-1) = V[\mathbf{T}_r(t) | \mathbf{T}_r(t-1), \boldsymbol{\theta}] \quad (3.14)$$

and the one step prediction error

$$\boldsymbol{\varepsilon}(t) = \mathbf{T}(t) - \hat{\mathbf{T}}(t|t-1) \quad (3.15)$$

Then (3.11) can be reformulated to

$$L(\boldsymbol{\theta}; \mathbf{T}_r(N)) = \prod_{t=1}^N \left( \frac{1}{(2\pi)^{n/2} \sqrt{\det \mathbf{R}(t|t-1)}} \exp \left( -\frac{1}{2} \boldsymbol{\varepsilon}(t)^T \mathbf{R}(t|t-1)^{-1} \boldsymbol{\varepsilon}(t) \right) \right)$$

where  $n$  is the dimension of  $\mathbf{T}_r$ . To simplify the maximization the logarithm to the likelihood function is maximized instead

$$l(\boldsymbol{\theta}; \mathbf{T}_r(N)) = \log \left( \prod_{t=1}^N \left( \frac{1}{(2\pi)^{n/2} \sqrt{\det \mathbf{R}(t|t-1)}} \exp \left( -\frac{1}{2} \boldsymbol{\varepsilon}(t)^T \mathbf{R}(t|t-1)^{-1} \boldsymbol{\varepsilon}(t) \right) \right) \right) \quad (3.16)$$

$$= -\frac{m}{2} \sum_{t=1}^N (2\pi) - \frac{1}{2} \sum_{t=1}^N \log(\det \mathbf{R}(t|t-1)) + \frac{1}{2} \boldsymbol{\varepsilon}(t)^T \mathbf{R}(t|t-1)^{-1} \boldsymbol{\varepsilon}(t)$$

$$= \frac{1}{2} \sum_{t=1}^N [\boldsymbol{\varepsilon}(t)^T \mathbf{R}(t|t-1)^{-1} \boldsymbol{\varepsilon}(t) - \log(\det \mathbf{R}(t|t-1))] + C \quad (3.17)$$

where  $C$  is a constant. A Kalman filter can be applied to recursively calculate the conditional mean and variance.

The Kalman filter is a recursive filter, which can be used to estimate the states of a linear stochastic state space model, given observations of  $\mathbf{U}$  and  $\mathbf{T}$ . The reconstructed states and the corresponding covariance are

$$\hat{\mathbf{T}}(t|t) = \hat{\mathbf{T}}(t|t-1) + \mathbf{K}_t \left( \mathbf{T}_r(t) - \mathbf{C}\hat{\mathbf{T}}(t|t-1) \right) \mathbf{P}(t|t) = \mathbf{P}(t|t-1) - \mathbf{K}_t \mathbf{R}(t|t-1) \mathbf{K}_t^T$$

where  $\mathbf{K}_t$  is the Kalman gain given by

$$\mathbf{K}_t = \mathbf{P}(t|t-1) \mathbf{C}^T \mathbf{R}(t|t-1)^{-1} \quad (3.18)$$

The predicted states are given by

$$\begin{aligned} \hat{\mathbf{T}}(t+1|t) &= \mathbf{\Phi} \hat{\mathbf{T}}(t|t) + \mathbf{\Gamma} \mathbf{U}(t) \\ \hat{\mathbf{T}}_r(t+1|t) &= \mathbf{C} \hat{\mathbf{T}}(t+1|t) \\ \mathbf{P}(t+1|t) &= \mathbf{\Phi} \mathbf{P}(t|t) \mathbf{\Phi}^T + \mathbf{R}_1 \\ \mathbf{R}(t+1|t) &= \mathbf{C} \mathbf{P}(t+1|t) \mathbf{C}^T + \mathbf{R}_2 \end{aligned}$$

where following initial conditions are used

$$\begin{aligned} \hat{\mathbf{T}}(1|0) &= E[\mathbf{T}(1)] = \boldsymbol{\mu}_0 \\ \mathbf{P}(1|0) &= V[\mathbf{T}(1)] = \mathbf{V}_0 \end{aligned}$$

Asymptotically it holds for the maximum likelihood estimator that the variance of the estimate is given by

$$V[\hat{\boldsymbol{\theta}}] = \mathbf{I}^{-1}(\hat{\boldsymbol{\theta}}) \quad (3.19)$$

where

$$\mathbf{I}(\boldsymbol{\theta}) = -E \left[ \frac{\partial^2 \log L}{\partial \boldsymbol{\theta}^2} \right] \quad (3.20)$$

In practice

$$\mathbf{I}(\boldsymbol{\theta}) = - \left[ \frac{\partial^2 \log L}{\partial \boldsymbol{\theta}^2} \right]_{\boldsymbol{\theta}=\hat{\boldsymbol{\theta}}} \quad (3.21)$$

is used. From this the variance and p-value for the parameters are found.



### 3.3 CTSM - Continuous Time Stochastic Modelling

A routine for maximizing the conditional likelihood function has been implemented in CTSM, which is a continuous time stochastic modelling tool. CTSM can be used to estimate parameters in both linear time invariant-, linear time varying- and nonlinear models. The estimated parameters can either be found using the maximum likelihood (ML) method or the maximum a posteriori (MAP) method. The maximum a posteriori estimator is not used in this project, but [5] contains more information. When the maximum likelihood estimator has been found for  $L(\mathbf{T}_r(N); \boldsymbol{\theta})$  CTSM returns the estimate of  $\boldsymbol{\theta}$ .

CTSM also estimates the standard deviation of the estimated parameters. This is given by the estimated variance, which is found by setting the expected value in (3.20) equal to the observed value, i.e.

$$i_{lk} = - \left( \frac{\partial^2 \log L(\boldsymbol{\theta}; \mathbf{T}_r(N);)}{\partial \theta_l \partial \theta_k} \right) \quad (3.22)$$

CTSM has been developed at Department of Informatics and Mathematical Modeling (IMM) at the Technical University of Denmark, (DTU), and can be downloaded from IMM's homepage <sup>1</sup>, where a user's guide [6] is also available.

#### 3.3.1 Modelling in CTSM

Due to the ease of use, CTSM has been chosen for estimation of the parameters in (2.23). When a model, of the same form as (3.8), has been formulated it can easily be entered using the graphical user interface of CTSM. When the number of states, input and output have been defined, CTSM sets up the matrices,  $\mathbf{A}$ ,  $\mathbf{B}$ ,  $\mathbf{C}$  and  $\mathbf{D}$ , defined in (2.23) and (2.24). When the matrices have been filled out it can be selected how to estimate each parameter, i.e. ML, MAP or if it is fixed. Boundaries are defined for each parameter that is to be estimated. It should be noted, that  $\pm\infty$  and 0 should be avoided as boundary and initial values for the parameter estimation. Finally a source of data, which contain time, input and measured output, is specified and the parameters are estimated.

---

<sup>1</sup><http://www2.imm.dtu.dk/~ctsm/>

## 3.4 Time constants

Time constants characterizes the frequency response of a system. Physically, a single time constant represents the time it takes the system's step response to reach approximately 63% of its final (asymptotic) value. The  $i$ 'th time constant of a linear state space model is

$$\tau_i = -\frac{1}{\lambda_i} \quad (3.23)$$

where  $\lambda_i$  is the  $i$ 'th largest eigenvalue of  $\mathbf{A}$  defined in (2.22).

## 3.5 Tests for model selection

Statistical tests that can be utilized in the search for the most appropriate model are useful. If a model is a submodel of larger model then a likelihood ratio test can determine if the larger model performs significantly better than the submodel. Using such tests a strategy for selection of the best model can be evolved.

### 3.5.1 Likelihood ratio tests

Let a model have parameters  $\theta \in \Omega_0$  where  $\Omega_0 \in \mathbb{R}^r$  is the parameter space and  $r = \dim(\Omega_0)$  is the number of parameters in the model. Let a larger model have parameters  $\theta \in \Omega$  where  $\Omega \in \mathbb{R}^m$  and  $\dim(\Omega) = m$ , and

$$\Omega_0 \subset \Omega, \quad (3.24)$$

i.e. the first model is a submodel of the second model and  $r < m$ .

The likelihood ratio test

$$\lambda(y) = \frac{\sup_{\theta \in \Omega_0} L(\theta; y)}{\sup_{\theta \in \Omega} L(\theta; y)} \quad (3.25)$$

where  $y$  is the observed values, can then be used to test the hypothesis

$$H_0 : \theta \in \Omega_0 \quad \text{vs.} \quad H_a : \theta \in \Omega \setminus \Omega_0, \quad (3.26)$$

since under  $H_0$  the test statistic  $-2\log(\lambda(y))$  converges to a  $\chi^2$  distributed random variable with  $(m - r)$  degrees of freedom as the number of samples in  $y$  goes to infinity. If  $H_0$  is rejected then the likelihood of the larger model is significant compared to the likelihood of the submodel, and it is found that  $y$  is more likely to be observed with the larger model. Hence the larger model is needed over the sub-model to describe information in data. For more details see (??HMs nye bog).

### **3.5.2 Forward selection**

In a forward model selection procedure the modeller starts with the smallest feasible model and then in each step extends the model with the part that gives the lowest p-value. The possible parts that are selected among in each iteration are the smallest possible extensions to the current selected model. The procedure stops, when no extensions to the model, yields a p-value below a pre-specified limit, usually the limit is set to 5%.

# Chapter 4

## Model identification procedure

Different strategies for identifying a sufficient model is proposed in the literature and finding a suitable strategy depends on the specific modelling setup in which it shall be applied. An purely algorithmic and exhaustive selection procedure is seldomly feasible, hence iterative methods in which the modeller is partly involved in the selection is commonly applied. Here, a forward selection procedure is suggested for identification of a sufficient model for the heat dynamics. It is based on likelihood ratio tests described in Section 3.5.1.

### 4.1 Model selection

The procedure starts by a formulation of the simplest feasible model having a parameter space  $\Omega_M$  and the full model with the parameter space  $\Omega_{\text{full}}$ , such that

$$\Omega_M \subset \Omega_{\text{full}}. \quad (4.1)$$

Within this range, a set of models can be formed in which a sufficient model is to be identified. The model selection is initiated with the simplest model. Then a loop is carried out, in which extensions of the model are iteratively added. The model extension stops when any of the extensions to the selected model, will give a likelihood-ratio test p-value above the pre-specified limit. Hence procedure will stop with a model from which no larger model can be found, with which it is more likely to observe the given data. As mentioned above a purely algorithmic procedure is not possible, hence the modeller must be involved to evaluate the models found in each iteration. The properties of residuals and parameter estimates must be evaluated and if some of the properties are not in line with assumptions and physical reality the modeller

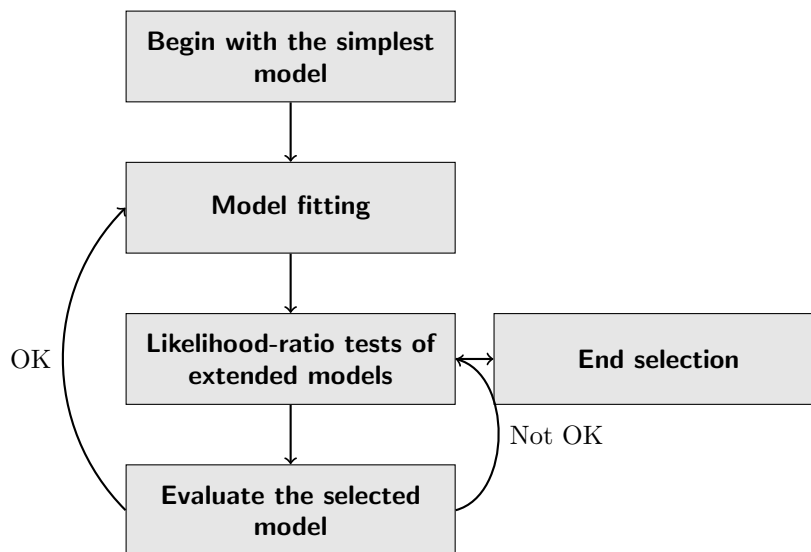

Figure 4.1: Illustration of the model identification procedure

have to influence the choice of model. The procedure is illustrated in Figure 4.1 and here the steps are described

**Model fitting** The models which are extended from the currently selected model are fitted to the data by maximum likelihood estimation of the parameters.

**Likelihood-ratio tests** Calculate the the likelihood-ratio test statistic for the current model versus each of the extended models. Select the extended model which have the lowest p-value of the test below 5%. Stop if none of the tests have a p-value below 5%.

**Evaluate** The modeller evaluates the selected extended model. If the result is satisfactory the model is kept and next iteration can started, if not another model should be selected in the previous step.

If two extensions show an almost identical improvement, i.e. the p-values of the tests are nearly equal, the selection can be branched and extensions with different parts are examined seperately. The procedure will then end with several models, which cannot be tested directly agaist each other, and it is then up to the modeller to decide which should be prepered. This should be done by comparing the likelihoods, where if two models have almost equal likelihoods the smaller model should be preferred, and by an evaluation of the residuals and parameter estimates. It can also be the case that more than

one model has only marginal different performance and that they describe the data equally well.

### **4.1.1 Model evaluation**

In each step the selected model should be evaluated. This serves both to check if the model gives reasonable results according to both assumptions and estimates of physical values, and to reveal model deficiencies from which it can be learned which parts of the model should be further elaborated. The evaluation should consist of the following

- The assumptions of white noise residuals should be inferred upon with the ACF and the cumulated periodogram, which can also reveal how well dynamics on different timescales are modelled.
- Plots of the inputs and the residuals. These plots can be used to understand which effects is not reflected properly by the model.
- Evaluation of the estimated physical parameters. Clearly the results should be consistent among different models, e.g. estimate of the thermal resistance of the building envelope should not change significantly among the models. Furthermore the modeller have to judge if the results are consistent with reality.

# Chapter 5

## Identifying a model for FlexHouse

The proposed procedure is such, that the modeller starts with the simplest model and iteratively selects more complex models. This implies fitting a set of models from the simplest model to the most feasible complex model, here denoted the full model. In this section the set of applied models and the result of the iterative selection procedure is described. A given model is named from its state vector, which implicitly define the model. In Appendix B all applied models are illustrated with RC-diagrams.

### 5.1 Data

The present study is based on data which was collected during a series of experiments carried out in February to April 2009 in FlexHouse. The data is thoroughly described in [3]. The following time series consisting of five minutely values are used:

$T_r$  (°C) An single signal representing the indoor temperature is formed as the first principal component of measurements of the indoor temperature from Hobo sensors (see [3]), which are hanging freely in the middle of each room in the building.

$T_a$  (°C) Observed ambient temperature from a climate station located 2 meters from the building.

$\Phi_h$  (kW) Total heat input to the electrical heaters in the building.

$G$  (kW/m<sup>2</sup>) The global irradiance measured at the climate station.

Plots of the time series can be found in Figure 5.1. The controlled heat input is a Pseudo-random binary sequence (PRBS), which has white noise properties and no correlation with other inputs. It is applied in order to optimize the information embedded in data [8].

## 5.2 Applied models

In this section a description is given of the set of applied models in the selection, ranging from the simplest to the full model. The models are all linear and can all be written

$$d\mathbf{T} = \mathbf{A}\mathbf{T}dt + \mathbf{B}\mathbf{U}dt + d\omega(t) \quad (5.1)$$

where  $\mathbf{T}$  is the state vector and  $\mathbf{U}$  is the input vector, and none of the state variables or input variables are in  $\mathbf{A}$  or  $\mathbf{B}$  which only consist of parameters. All the considered linear models have an input vector with three inputs

$$\mathbf{U} = [T_a, \Phi_s, \Phi_h]^T. \quad (5.2)$$

where

- $T_a$  is the temperature of the ambient environment,
- $\Phi_s$  is the solar irradiance on the building,
- $\Phi_h$  is the heat from the electrical heaters inside the building.

The models are all lumped, but with a different structure which implies that a given parameter does not necessarily represent the same physical entity in different models. For example is the parameter  $C_i$  representing the heat capacity of the entire building in the simplest model, whereas this is divided into five heat capacities in the full model, where the parameter  $C_i$  represents the heat capacity of the indoor air. This is elaborated further in Chapter 5.2, where the parameter estimates for the models are presented. Furthermore it should be kept in mind that these models are linear approximations to the real system. The models are named after their state vector and if needed an extra abbreviated description. In the following sections the full and the simplest model are described, since they represent the range of applied models. First the full model is described to give a complete overview of all the individual parts, which is included in the models. Then the simplest model is described since it is the first model applied in the selection procedure and since it illustrates how the models are lumped. See Appendix B for RC-diagrams of all selected model.



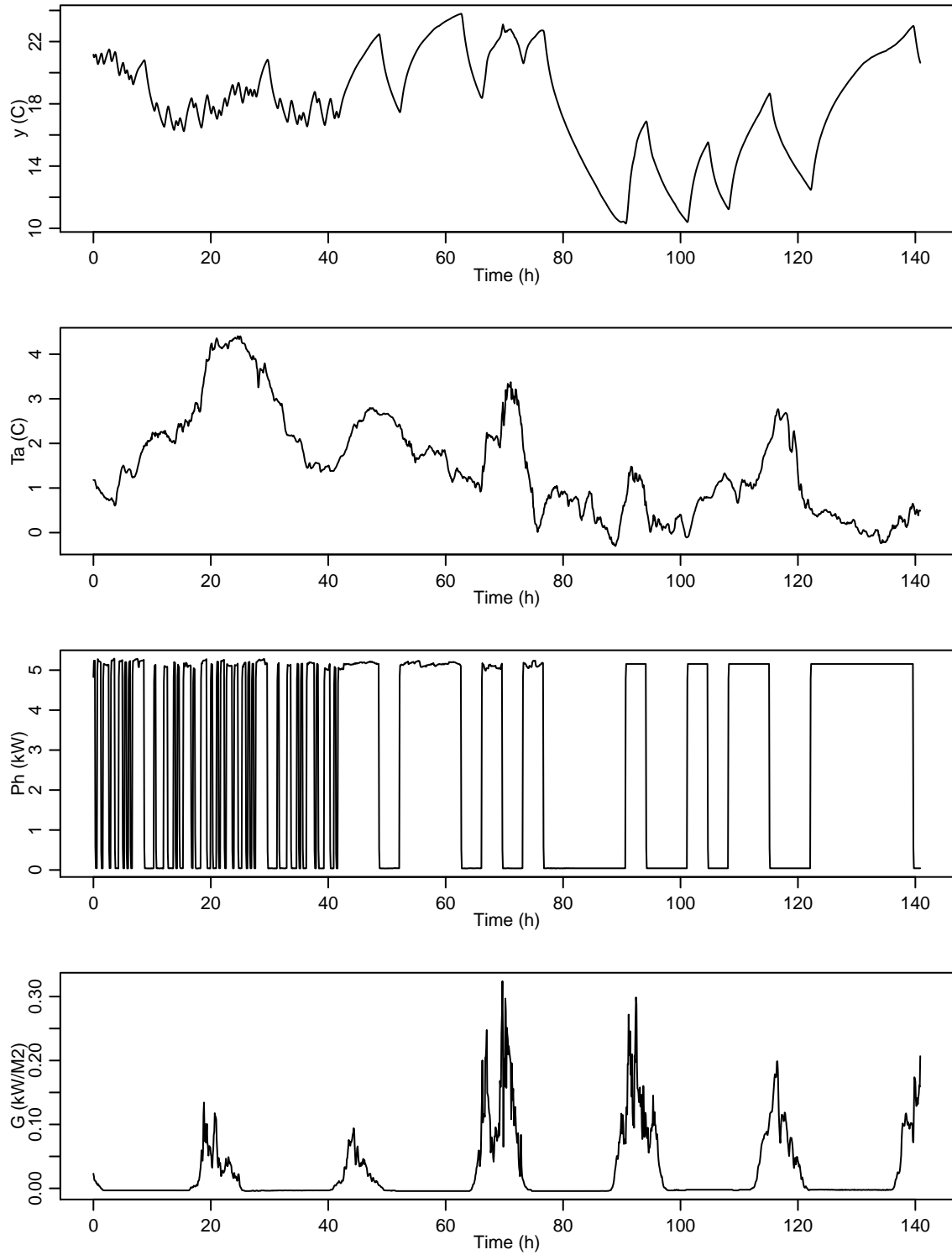

Figure 5.1: The data set. From the top, the first plot shows the measured indoor temperature, the second shows the observed ambient temperature, followed by a plot of the heat input, and finally a plot shows the global irradiance.

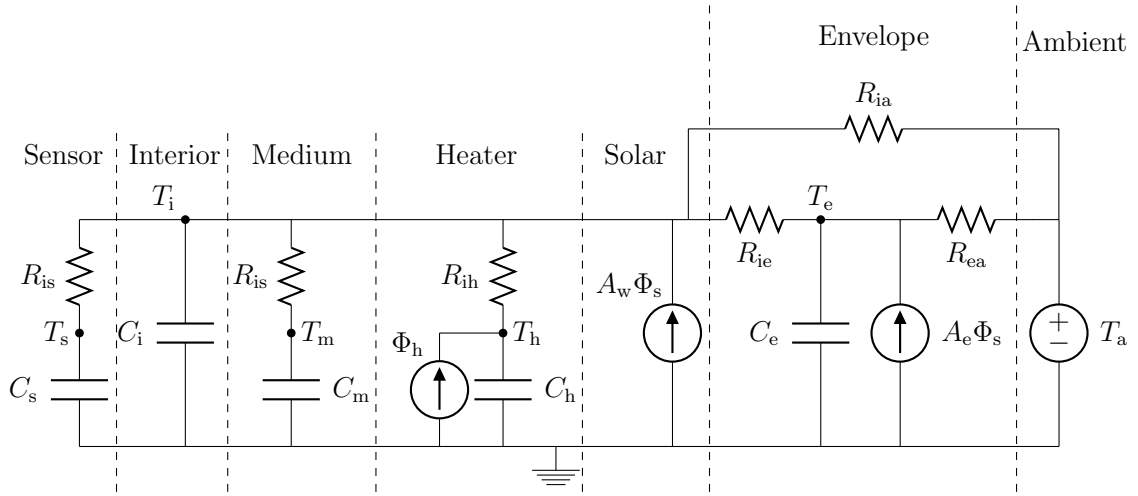

Figure 5.2: The full model  $T_iT_mT_eT_hT_sA_eR_{ia}$  with the individual model parts indicated. This model includes all parts which is included in any of the applied models.

### 5.2.1 The full model $T_iT_mT_eT_hT_sA_eR_{ia}$

The full model, which is the most complex model applied is illustrated in Figure 5.2. This model includes all the individual parts of the building, which it is found feasible to include into linear models, with the current available data. The individual model parts are indicated on the figure and they are

**Sensor** The temperature sensors are modelled with a heat capacity and a thermal resistance to the interior.

**Interior** The interior is considered to be the indoor air (again depending on which other parts are included into the model) and it is modelled as a heat capacity connected to other parts by thermal resistances.

**Medium** A thermal medium inside the building is the interior walls and furniture, which are modelled with a heat capacity and a thermal resistance to the interior.

**Heaters** The heaters are modelled by a heat capacity and a thermal resistance to the interior.

**Solar** The heat input from solar radiation is modelled by the global irradiance times a coefficient.

**Envelope** The building envelope is modelled with a heat capacity and thermal resistances to both the interior and the ambient environment. A thermal resistance directly coupled to the ambient is also included.

**Ambient** The ambient environment is the observed ambient temperature.

The model includes five state variables, that each represents the temperature in a part of the building. The representation of the parameters for this model is the following:

$T_s$  The temperature of the sensor, which for this model is the model output (i.e.  $T_r$  in the measurement equation).

$T_i$  The temperature of the interior, i.e. the indoor air.

$T_m$  The temperature of an interior thermal medium, i.e. interior walls and furniture.

$T_h$  The temperature of the heater.

$T_e$  The temperature of the building envelope.

The parameters of the model represent different thermal properties of the building. This includes thermal resistances

$R_{is}$  between the indoor air and the sensor,

$R_{im}$  between the indoor and the interior thermal medium,

$R_{ih}$  between the heaters and the indoor air,

$R_{ia}$  between the indoor air and the ambient environment,

$R_{ie}$  between from the indoor air and the building. envelope.

$R_{ea}$  between the building envelope and the ambient environment.

The heat capacities of different parts of the building is represented by

$C_s$  for the temperature sensor,

$C_i$  for the indoor air,

$C_m$  for the interior walls and furniture,

$C_h$  for the electrical heaters,

$C_e$  for the building envelope.

Finally two coefficients is included, each representing an estimate of an effective area, in which the energy from solar radiation enters the the building. They are

$A_w$  The effective window area of the building (see Section 2.1.2).

$A_e$  The effective area in which the solar radiation enters the building envelope.

The stochastic differential equations describing the heat flows are

$$C_s \frac{dT_s}{dt} = \frac{1}{R_{ih}}(T_i - T_s) + \sigma_s \frac{dW}{dt} \quad (5.3)$$

$$C_i \frac{dT_i}{dt} = \frac{1}{R_{is}}(T_s - T_i) + \frac{1}{R_{is}}(T_m - T_i) + \frac{1}{R_{ih}}(T_h - T_i) \quad (5.4)$$

$$\frac{1}{R_{ie}}(T_e - T_i) + \frac{1}{R_{ia}}(T_a - T_i) + A_w \Phi_s + \sigma_i \frac{dW}{dt} \quad (5.5)$$

$$C_m \frac{dT_m}{dt} = \frac{1}{R_{is}}(T_i - T_m) + \sigma_m \frac{dW}{dt} \quad (5.6)$$

$$C_h \frac{dT_h}{dt} = \frac{1}{R_{ih}}(T_i - T_h) + \Phi_h + \sigma_h \frac{dW}{dt} \quad (5.7)$$

$$C_e \frac{dT_e}{dt} = \frac{1}{R_{ie}}(T_i - T_e) + \frac{1}{R_{ea}}(T_a - T_e) + A_e \Phi_s + \sigma_e \frac{dW}{dt} \quad (5.8)$$

and the measurement equation is

$$T_k^r = T_k^s + e_k \quad (5.9)$$

since the recorded temperatur is approximated by the state variable  $T_s$ .

### 5.2.2 The simplest model $T_i$

The most simple model considered is illustrated by the RC-network in Figure 5.3. The model has one state variable  $T_i$  and the following parameters

- $R_{ia}$  The thermal resistance from the indoor to the ambient environment.
- $C_i$  The heat capacity of the entire building, including the indoor air, interior walls, funiture etc., and the building envelope.
- $A_w$  is the effective window area of the house (see Section 2.1.2).

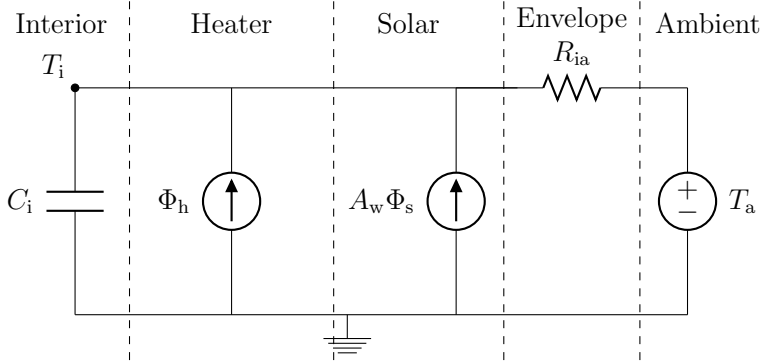

Figure 5.3: RC-network diagram of  $T_i$  which is the simplest feasible model.

The stochastic differential equation describing the heat flow is

$$C_i \frac{dT_i}{dt} = \frac{1}{R_{ia}} (T_a - T_i) + A_w \Phi_s + \Phi_h + \sigma_i \frac{dW}{dt} \quad (5.10)$$

and the measurement equation is

$$T_k^r = T_k^i + e_k. \quad (5.11)$$

Note especially the differences in representation of the building parts between the simplest and full model, e.g.  $R_{ia}$  represent the thermal resistance of the building envelope in the simplest model, whereas this is represented by a coupling of  $R_{ia}$ ,  $R_{ie}$  and  $R_{ea}$ .

## 5.3 Model identification

The identification procedure is here applied to find a sufficient model in the set of model ranging from  $T_i$  to  $T_i T_m T_e T_h T_s A_e R_{ia}$ . First the selection of a sufficient model is outlined, this is followed by an evaluation of the selected models, and finally the selected model is throughly evaluated.

### 5.3.1 Model selection

The loglikelihood of each model which is fitted is listed in Table 5.1 ordered by the iterations of the model selection. The procedure begins with the simplest model and in the first iteration four extended models are fitted and  $T_i T_h$  is selected since it has the highest loglikelihood and hence the lowest p-value of the likelihood-ratio tests. The selection procedure is carried out until no significant extension can be found, which occurs in iteration No. 5.

Iteration	Models			
<b>Begin</b>	<i>Ti</i>			
$l(\theta; y)$	2482.6			
$p$	6			
<b>1</b>	<i>TiTe</i>	<i>TiTm</i>	<i>TiTs</i>	<i>TiTh</i>
$l(\theta; y)$	3628.0	3639.4	3884.4	3911.1
$p$	10	10	10	10
<b>2</b>	<i>TiThTs</i>	<i>TiTmTh</i>	<i>TiTeTh</i>	
$l(\theta; y)$	4017.0	5513.1	5517.1	
$p$	14	14	14	
<b>3</b>	<i>TiTeThRia</i>	<i>TiTeThAe</i>	<i>TiTmTeTh</i>	<i>TiTeThTs</i>
$l(\theta; y)$	5517.3	5520.5	5534.5	5612.4
$p$	15	15	18	18
<b>4</b>	<i>TiTeThTsRia</i>	<i>TiTmTeThTs</i>	<i>TiTeThTsAe</i>	
$l(\theta; y)$	5612.5	5612.9	5614.6	
$p$	19	22	19	
<b>5</b>	<i>TiTmTeThTsAe</i>	<i>TiTeThTsAeRia</i>		
$l(\theta; y)$	5614.6	5614.7		
$p$	23	20		

Table 5.1: Loglikelihood for the fitted models ordered by iterations of the model selection procedure and in each row by loglikelihood. In each iteration the extended model with highest loglikelihood is selected, which is the rightmost models.  $p$  is the number of estimated parameters for each model.

During each iteration the current selected model is evaluated, see Section 5.3.2. It is found that the selected models are all found to satisfy the evaluation with respect to improvement of the results etc. in each iteration. In Table 5.2 the result of likelihood-ratio tests for model expansion in each iteration is listed. Clearly the expansion carried out in the first three iterations indicate very significant improvement of the model. In iteration No. 4, the improvement is still below 5%, whereas no improvement is found in iteration five. The procedure thus ends with *TiTeThTsAe* as a sufficient model, which is illustrated by the RC-network diagram in Figure 5.4.

### 5.3.2 Model evaluation

The selected models are evaluated as outlined in Section 4.1.1.

Iteration	Submodel	Model	$m - r$	$-2\log(\lambda(y))$	p-value
1	$T_i$	$T_iTh$	4	4121	$< 10^{-16}$
2	$T_iTh$	$T_iTeTh$	4	4634	$< 10^{-16}$
3	$T_iTeTh$	$T_iTeThTs$	4	274	$< 10^{-16}$
4	$T_iTeThTs$	$T_iTeThTsAe$	1	6.4	0.011
5	$T_iTeThTsAe$	$T_iTeThTsAeRia$	1	0.17	0.68

Table 5.2: Tests carried out in the model selection procedure.

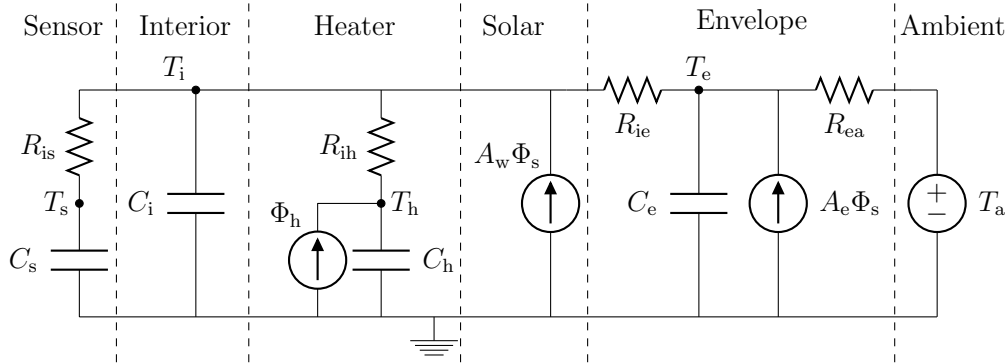

Figure 5.4: The final selected model  $T_iTeThTsAe$  with the individual model parts indicated.

## Residuals

Plots of inputs and residuals for each of the selected models is found in Appendix A. The plot of the inputs and residuals for the simplest model  $T_i$  can be seen in Figure A.1. It is seen directly from the plot of the residuals that they do not have white noise properties and that they are not independent of the inputs and output. The ACF of the residuals also clearly show a high lag dependency. The cumulated periodogram (CP) reveal that the model is too stiff to reflected the dynamics. Plots of the residuals for the model selected in the first iteration,  $T_iTh$ , can be seen in Figure A.2, where it seen that the level of residuals are reduced compared to the residuals for  $T_i$ . The ACF and the CP indicate that the assumption of white noise residuals are not fulfilled. Plots of the residuals for the model selected in the second iteration,  $T_iTeTh$ , can be seen in Figure A.3. It is seen that the level of the residuals are reduced dramatically, and that some dependency of the inputs is still seen, mostly from the solar irradiance. The ACF reveals that the characteristics of the residuals are much closer to white noise, which is also seen from the CP, indicating that the model now reflect the dynamics of the system quite well. Plots of the residuals for the model selected in

the third iteration *TiTeThTs* can be seen in Figure A.4. Only very slight improvements are seen compared the previous model. Plots of the residuals for the final selected model *TiTeThTsAe* is seen in Figure A.5. Almost no differences can be observed from the previous model. The highest level of error can be observed where the solar irradiance is high, hence it is found that further improvement of the model should be focused on the part in which the solar radiation enters the building.

### Parameter estimates

The parameter estimates of the selected models are evaluated in the following. The estimates are presented in Table 5.3 together with the time constants calculated for each of the selected models. The total heat capacity and thermal resistance of the building envelope found by the selected models are presented in Table 5.4. As found by evaluating the residuals, see previous Section, the models *Ti* and *TiTh* doesn't reflect the dynamics of the system very well, which implies that the estimates of the heat capacities are not reliable. Estimates of the heat capacities found by the tree larger models are

Name	<i>Ti</i>	<i>TiTh</i>	<i>TiTeTh</i>	<i>TiTeThTs</i>	<i>TiTeThTsWithAe</i>
$C_i$	2.07	1.36	1.07	0.143	0.0928
$C_e$	-	-	2.92	3.24	3.32
$C_h$	-	0.309	0.00139	0.321	0.889
$C_s$	-	-	-	0.619	0.0549
$R_{ia}$	5.29	5.31	-	-	-
$R_{ie}$	-	-	0.863	0.909	0.897
$R_{ea}$	-	-	4.54	4.47	4.38
$R_{ih}$	-	0.639	93.4	0.383	0.146
$R_{is}$	-	-	-	0.115	1.89
$A_w$	7.89	6.22	5.64	6.03	5.75
$A_e$	-	-	-	-	3.87
$\tau_1$	10.9	0.16	0.129	0.0102	0.0102
$\tau_2$	-	8.9	0.668	0.105	0.105
$\tau_3$	-	-	18.4	0.786	0.788
$\tau_4$	-	-	-	19.6	19.3

Table 5.3: The estimated parameters. The heat capacities,  $C_x$ , are in [kWh/°C]. The thermal resistances,  $R_x$ , are in [°C/kW]. The areas,  $A_x$ , are in [m<sup>2</sup>]. The time constants,  $\tau_x$ , are in hours. Note that the physical interpretation most of the parameters is different for each model.



Model	$T_i$	$T_iTh$	$T_iTeTh$	$T_iTeThTs$	$T_iTeThTsAe$
$C$	2.07	1.67	3.99	4.32	4.36
$R$	5.29	5.31	5.40	5.38	5.28
$\alpha_{UA}$	1.55	1.55	1.52	1.53	1.55

Table 5.4: The total heat capacity [kWh/°C] and thermal resistance [°C/kW] of the building envelope found with the selected models. The UA-values  $\alpha_{UA}$  are in [W/(°Cm<sup>2</sup>)].

more credible, especially it is seen that the time constants are almost equal, indicating that the model comprise the same dynamics. The exact physical interpretation of the smaller heat capacities  $C_i$ ,  $C_h$ , and  $C_s$  cannot be given, since they are lumped parameters, but it is noted that their sum, for each of the three larger models, is quite close ranging from 1.03 to 1.08 [kWh/°C].

The total thermal resistance of the building envelope and thereby the UA-values is quite similarly determined for all models, as seen in Table 5.4.

# Chapter 6

## Conclusion

A procedure for identification of models for heat dynamics of a building has been described and applied on the basis of data from an experiment carried out in FlexHouse in February 2009. The procedure is based on likelihood-ratio tests combined with a forward selection strategy. The evaluated models are grey-box models, where a combination of prior physical knowledge and data-driven modelling is utilized. The input to the models consist of: climate data measured at the location, measurements of the indoor temperature, and a controlled heat input.

The results of the identification procedure are evaluated and discussed, both in a statistical and physical context. The evaluation reveal that the selected model meet the assumptions of white noise residuals, hence it can be applied to give reliable estimates consistent with reality. Furthermore model deficiencies are pointed out, from which further advancement of the model should be pursued, especially on the model part where the solar radiation input enters the building.

It has been shown that the procedure is able to provide rather detailed knowledge of the heat dynamics of the building. This includes for instance the thermal resistance of the envelope, the UA-value, and parameters describing the capabilities for storing heat.

# Appendix A

## Inputs and residuals

# Inputs and residuals

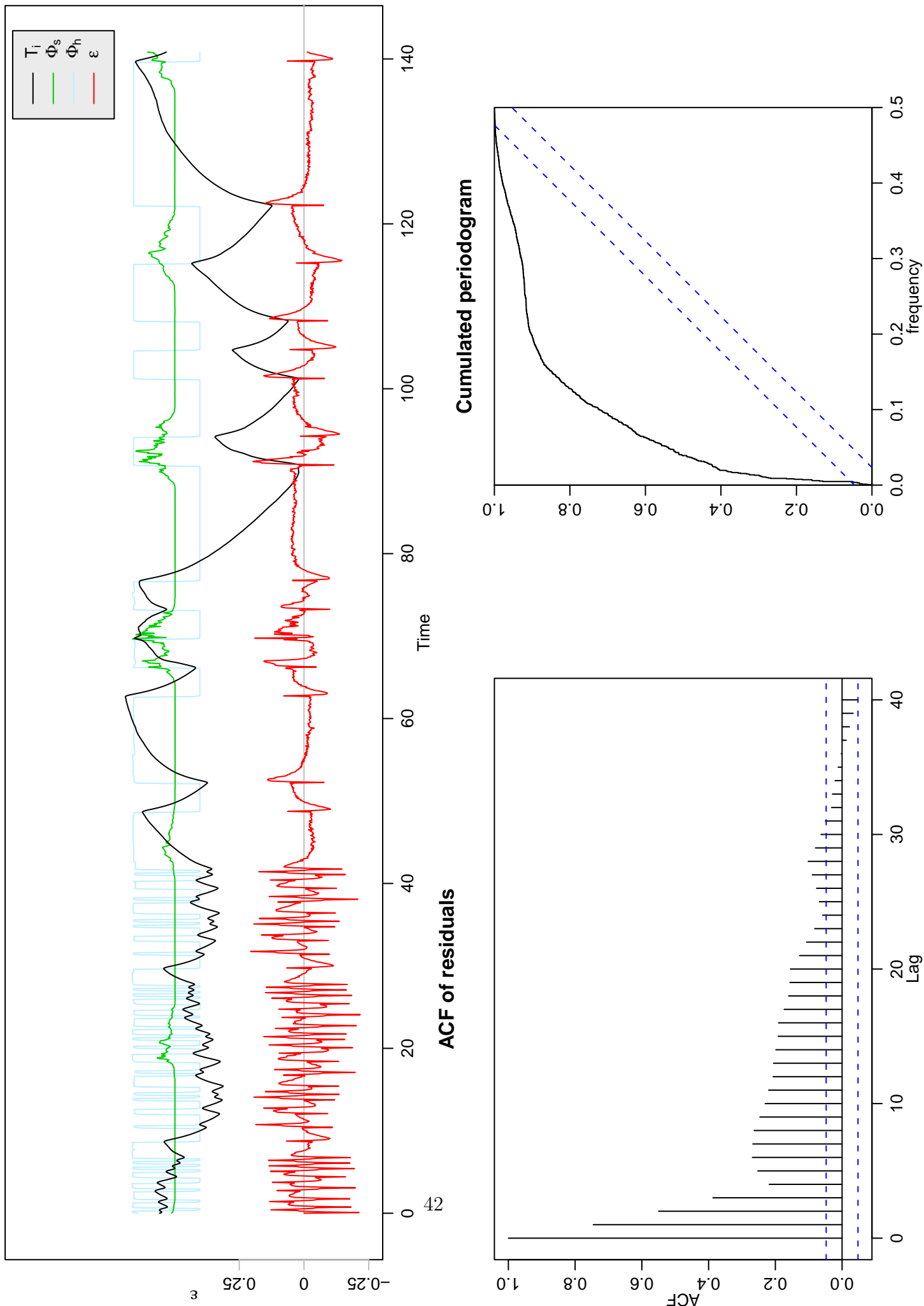

Figure A.1: Inputs and residuals for  $T_i$ .

# Inputs and residuals

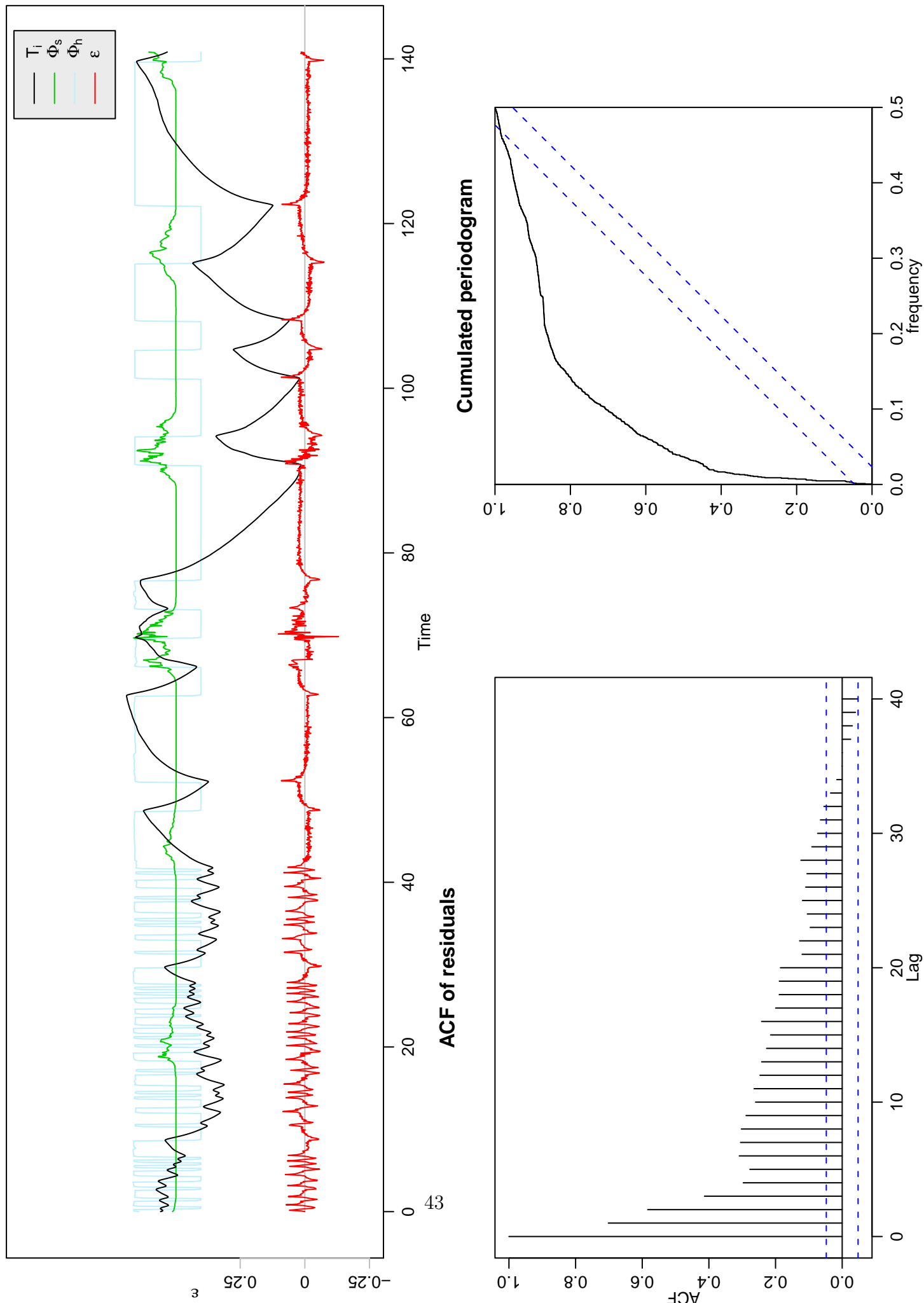
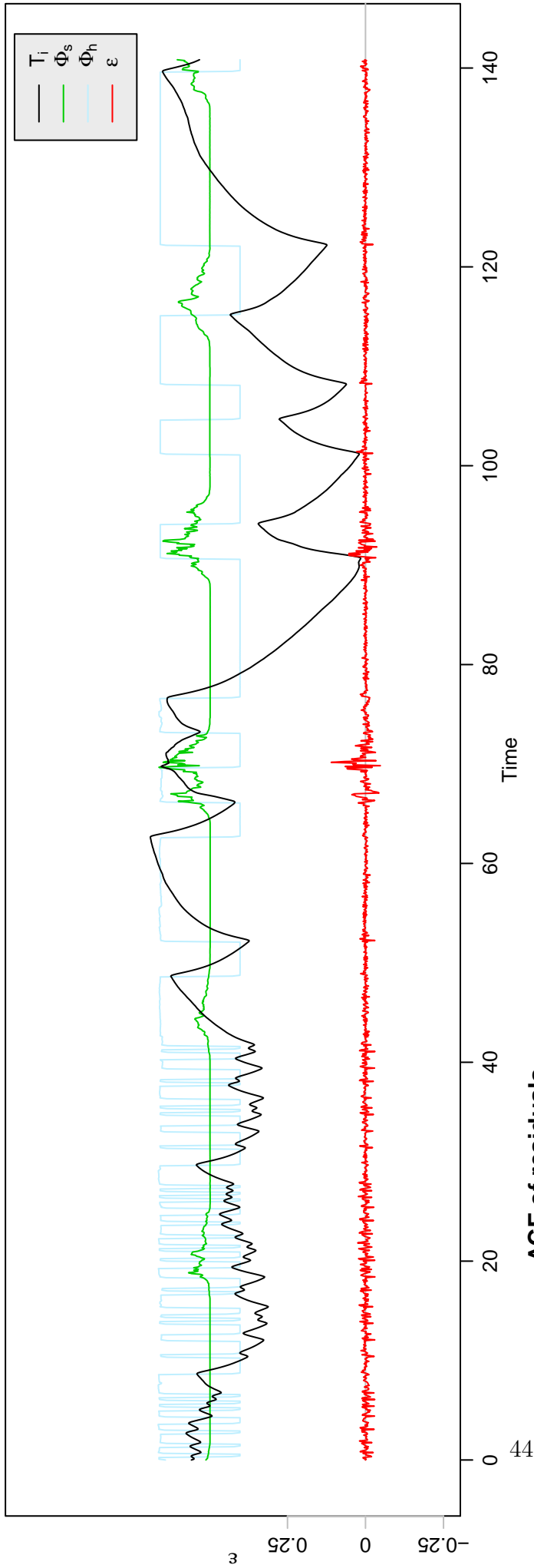
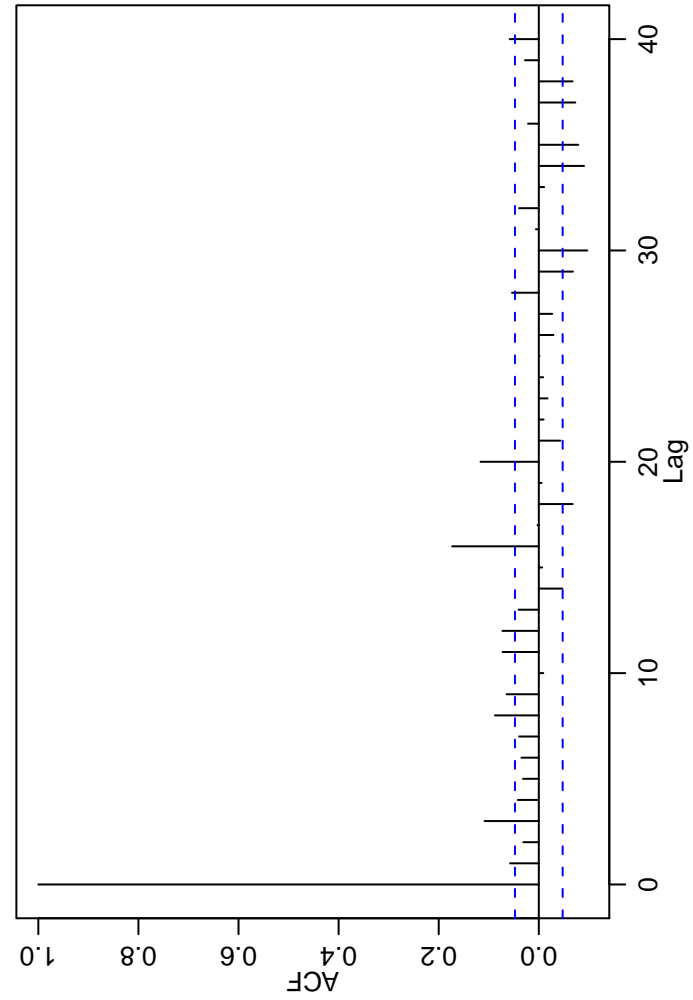

Figure A.2: Inputs and residuals for  $T_iTh$ .

# Inputs and residuals



# ACF of residuals



# Cumulated periodogram

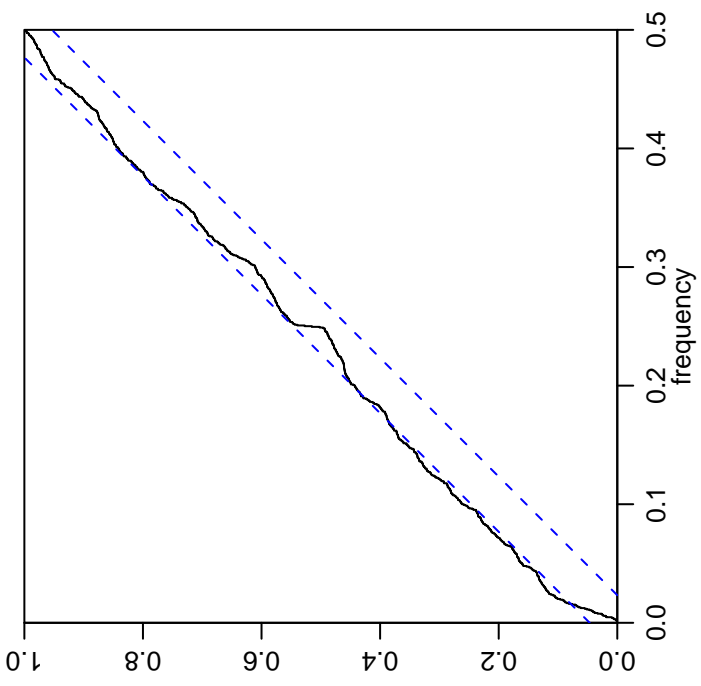
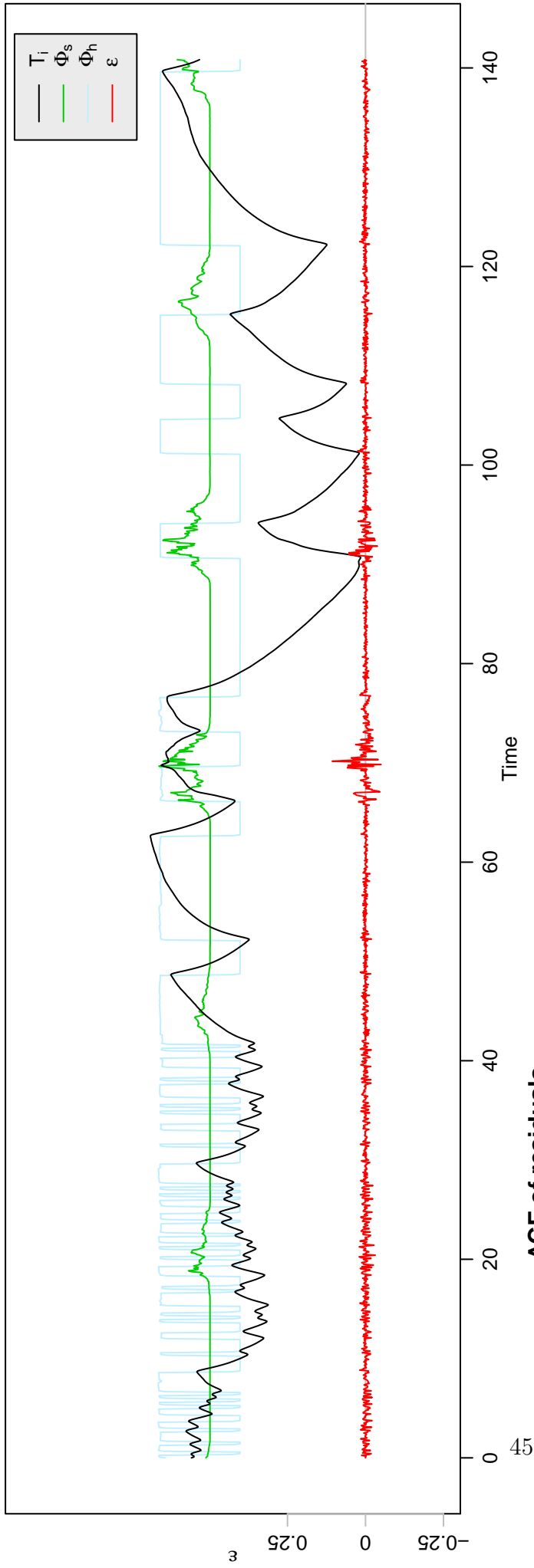
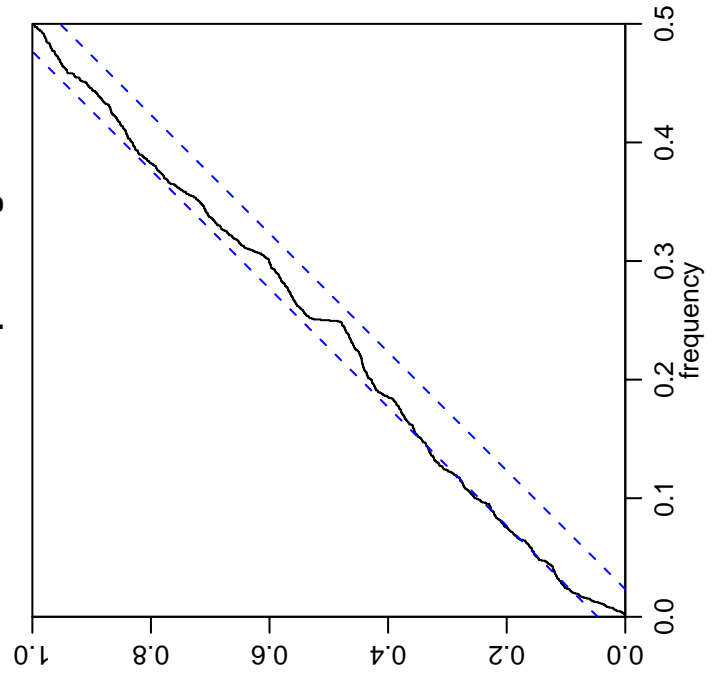

Figure A.3: Inputs and residuals for  $TiTeTh$ .

### Inputs and residuals



### Cumulated periodogram



### ACF of residuals

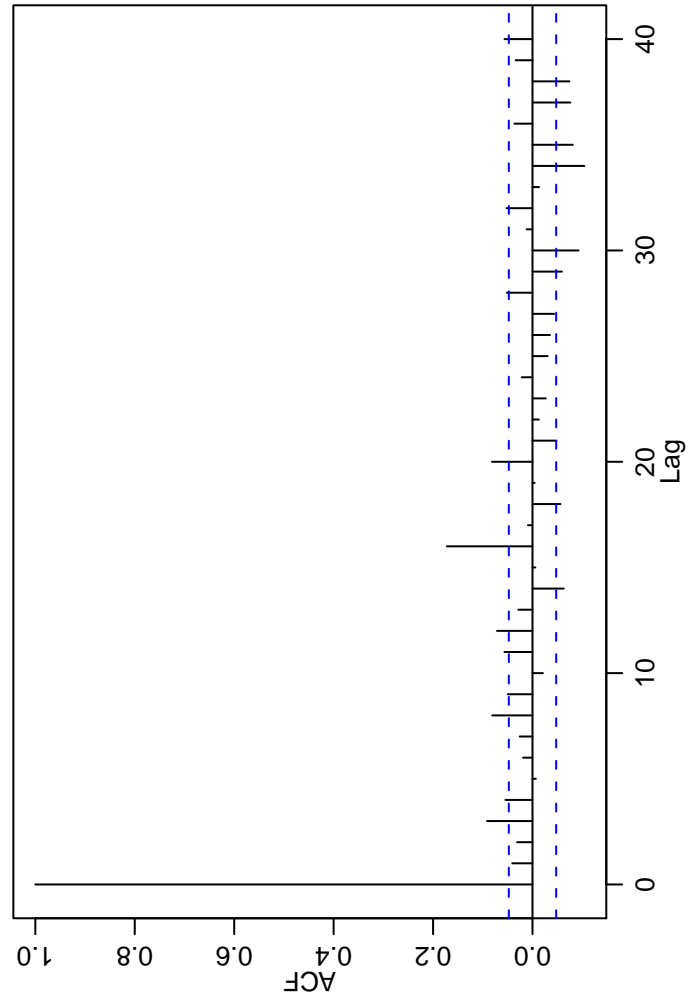

Figure A.4: Inputs and residuals for  $T_iTeThTs$ .

# Inputs and residuals

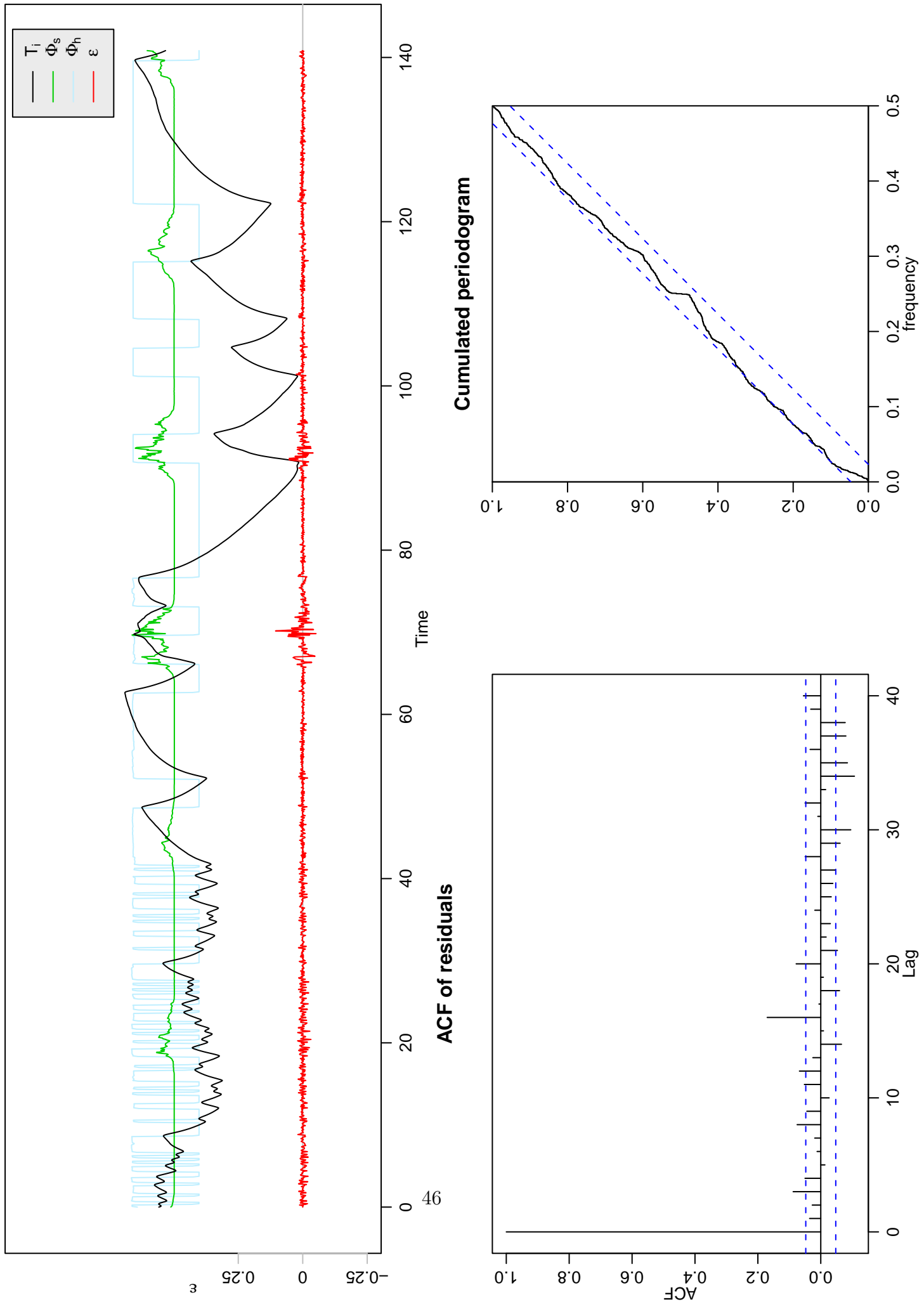

Figure A.5: Inputs and residuals for  $TiTeThTsAe$ .



# Appendix B

## RC-diagrams of applied models

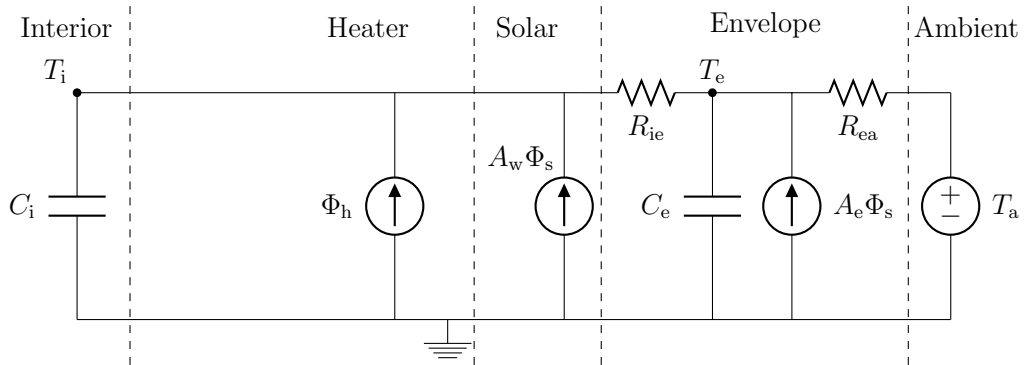

Figure B.1: RC-network diagram of  $T_iT_e$ .

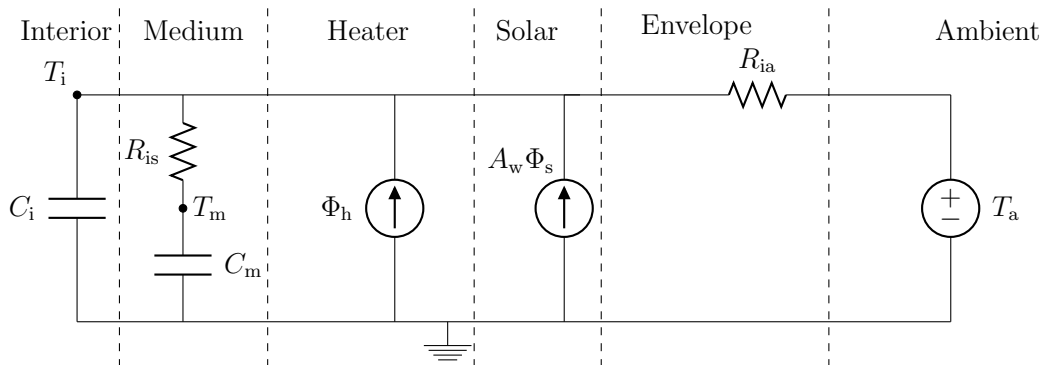

Figure B.2: RC-network diagram of  $T_iT_m$ .

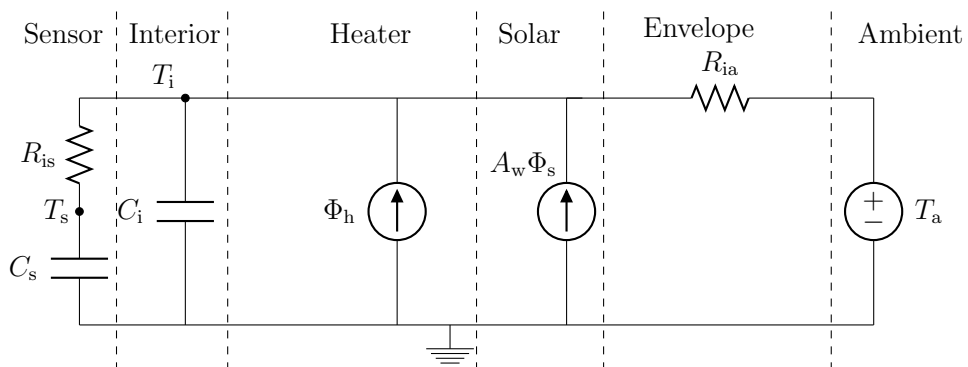

Figure B.3: RC-network diagram of  $T_iT_s$ .

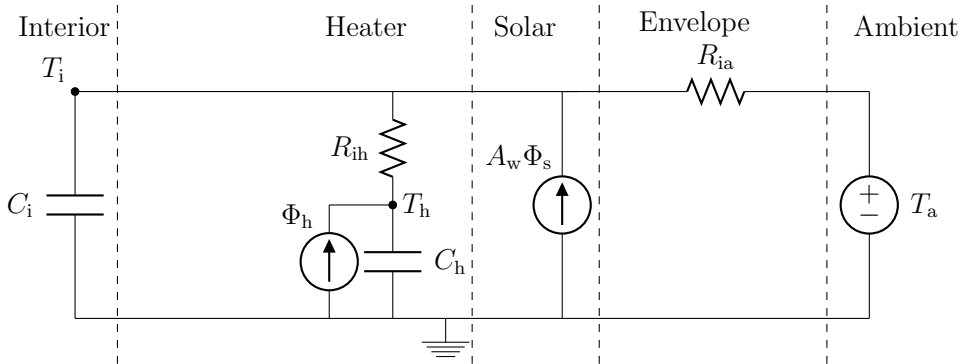

Figure B.4: RC-network diagram of  $T_iTh$ .

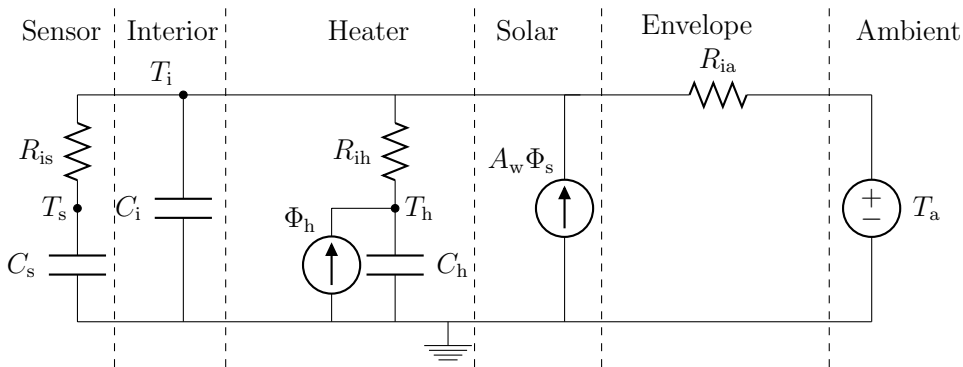

Figure B.5: RC-network diagram of  $T_iThTs$ .

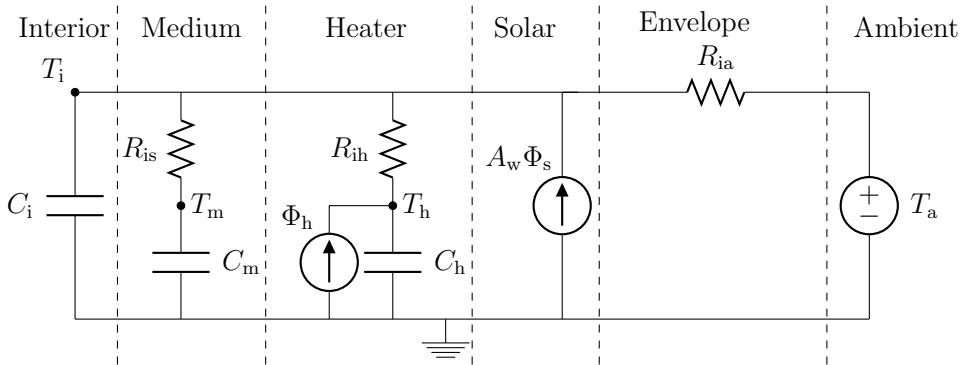

Figure B.6: RC-network diagram of  $T_iT_mTh$ .

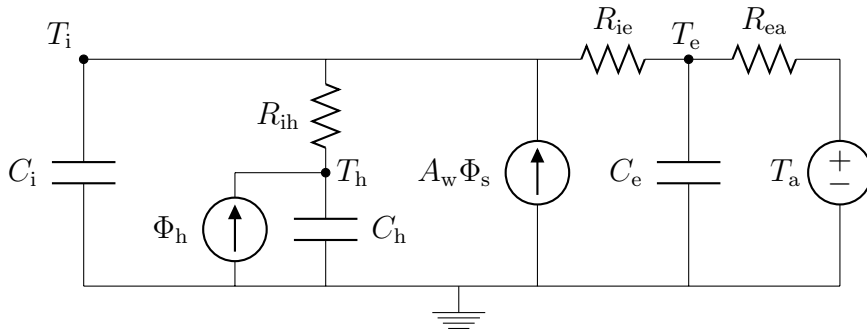

Figure B.7: RC-network diagram of  $T_iT_eTh$ .

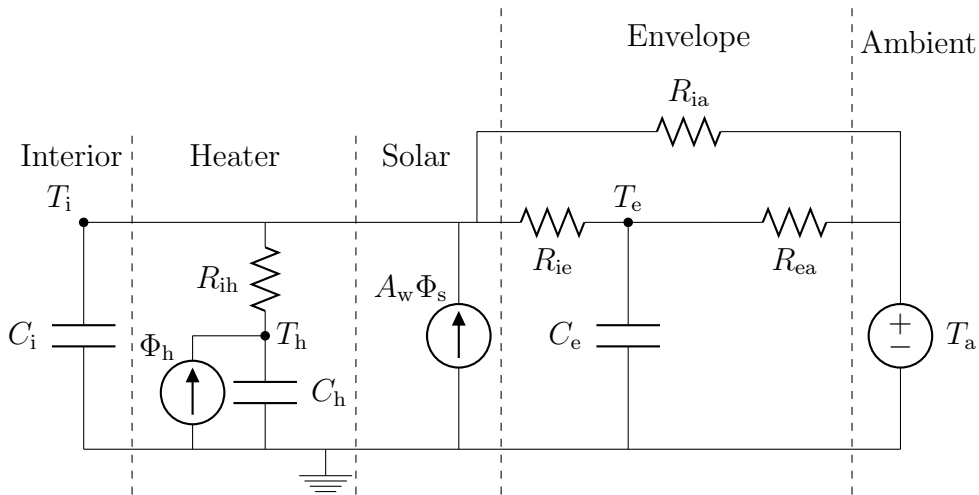

Figure B.8: RC-network diagram of  $T_iT_eThR_{ia}$ .

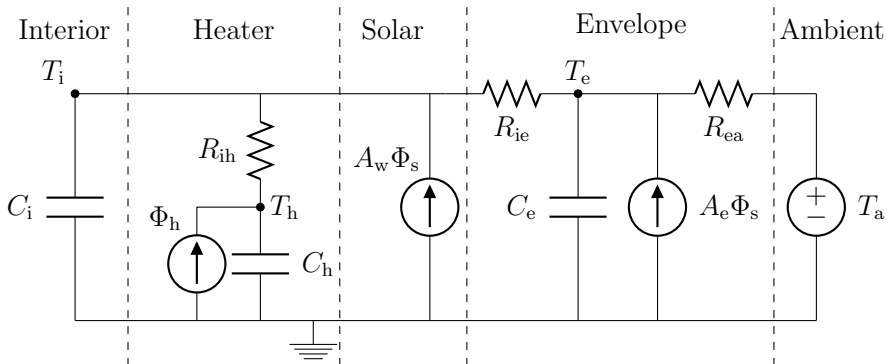

Figure B.9: RC-network diagram of  $T_iT_eThA_e$ .

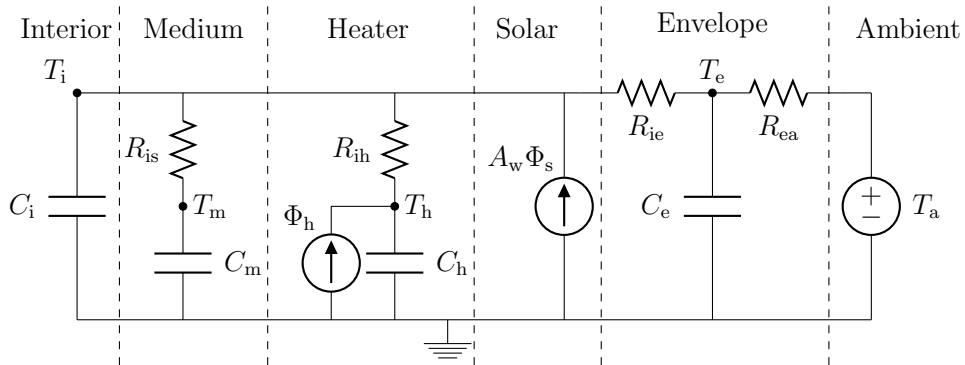

Figure B.10: RC-network diagram of  $T_iT_mT_eT_h$ .

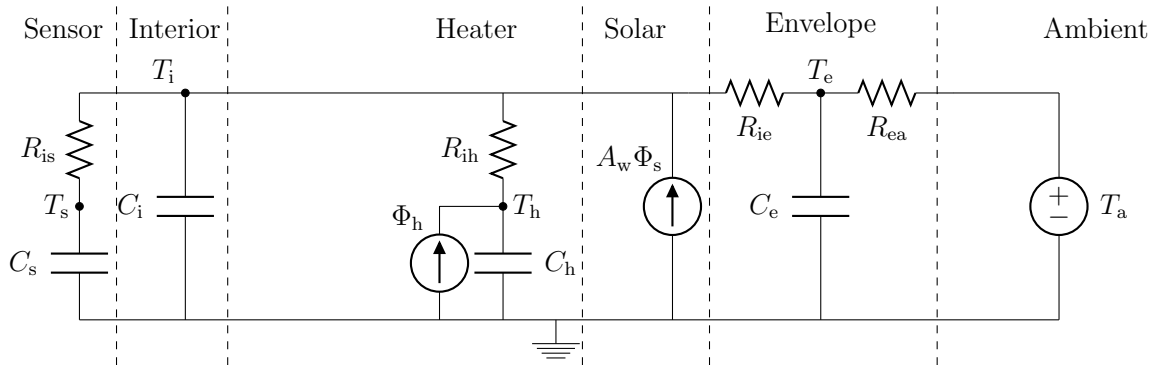

Figure B.11: RC-network diagram of  $T_iT_eT_hT_s$ .

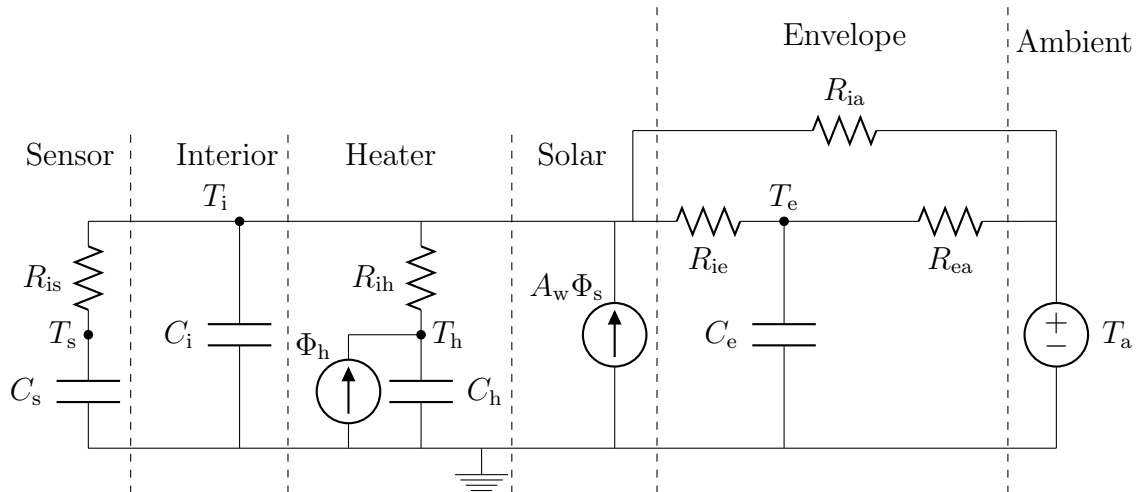

Figure B.12: RC-network diagram of  $T_iT_eT_hT_sR_{ia}$ .

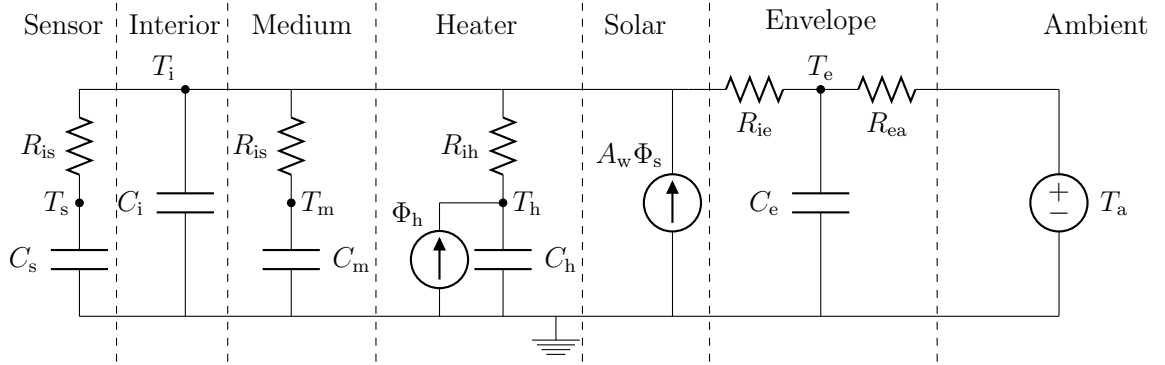

Figure B.13: RC-network diagram of  $T_i T_m T_e T_h T_s$ .

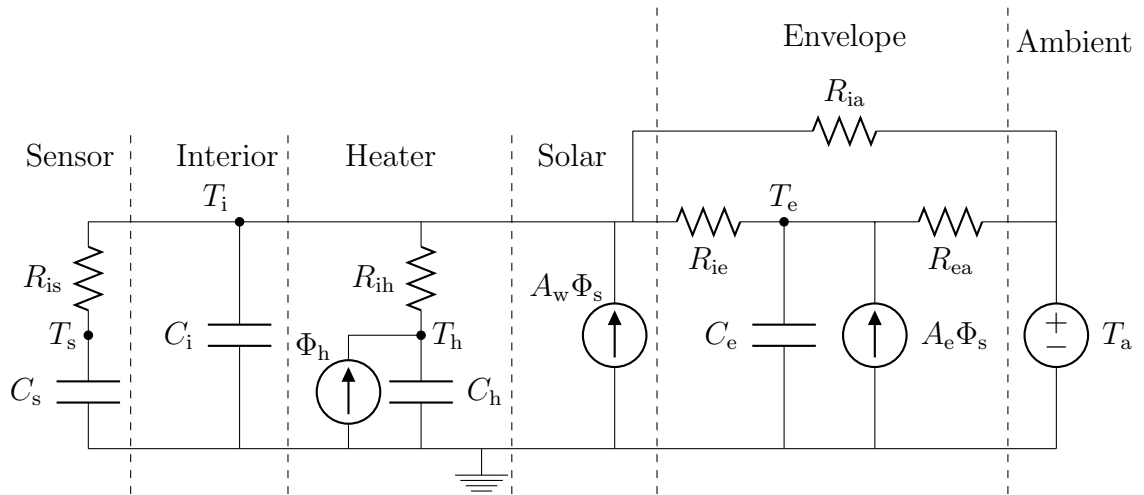

Figure B.14: RC-network diagram of  $T_i T_e T_h T_s A_e R_{ia}$ .

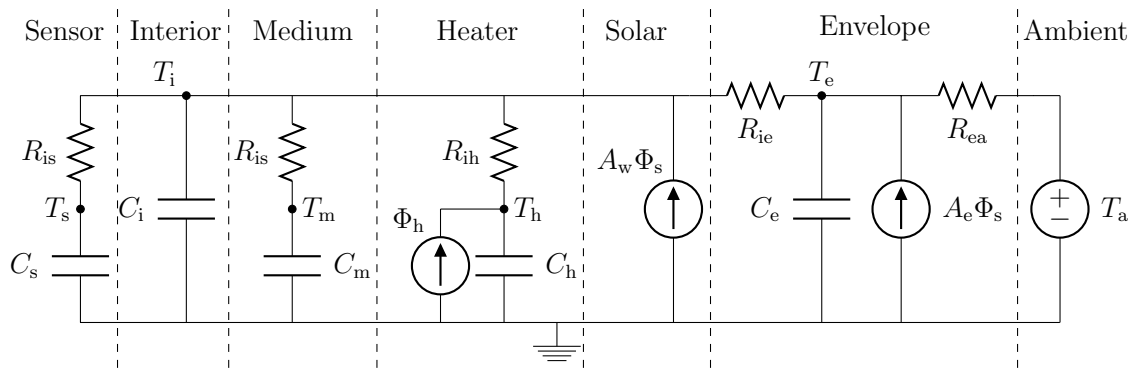

Figure B.15: RC-network diagram of  $T_i T_m T_e T_h T_s A_e$ .

# Bibliography

- [1] Klaus Kaae Andersen, Henrik Madsen, and Lars H. Hansen. Modelling the heat dynamics of a building using stochastic differential equations. *Energy and Buildings*, 31(1):13–24, 2000.
- [2] Ander Goikoetxea Arana. Flexhouse. Technical report, Risø DTU, 2007.
- [3] Peder Bacher and Henrik Madsen. Experiments and data for building energy performance analysis : Financed by the danish electricity saving trust. Technical report, DTU Informatics, Building 321, Kgs. Lyngby, 2010.
- [4] Tianzhen Hong, S.K. Chou, and T.Y. Bong. Building simulation: an overview of developments and information sources. *Building and Environment*, 35(4):347–361, 2000.
- [5] Niels Rode Kristensen and Henrik Madsen. Continuous time stochastic modelling, CTSM 2.3 - mathematics guide. Technical report, DTU, 2003.
- [6] Niels Rode Kristensen and Henrik Madsen. Continuous time stochastic modelling, CTSM 2.3 - user’s guide. Technical report, DTU, 2003.
- [7] H. Madsen and J. Holst. Estimation of continuous-time models for the heat dynamics of a building. *Energy and Buildings*, 22(1):67–79, 1995.
- [8] Henrik Madsen and J.M. Schultz. Short time determination of the heat dynamics of buildings. Technical report, DTU, 1993.
- [9] Henrik Aalborg Nielsen. Estimation of UA-values for single-family houses. Technical report, ENFOR, 2008.
- [10] Anders Thavlov, Peder Bacher, and Henrik Madsen. Data for energy performance analysis. Technical report, IMM, DTU, 2008.