

Technical University of Denmark



Squeezing based on nondegenerate frequency doubling internal to a realistic laser

Andersen, Ulrik Lund; Tidemand-Lichtenberg, Peter; Buchhave, Preben

Published in:
Physical Review A (Atomic, Molecular and Optical Physics)

Link to article, DOI:
[10.1103/PhysRevA.69.013908](https://doi.org/10.1103/PhysRevA.69.013908)

Publication date:
2004

Document Version
Publisher's PDF, also known as Version of record

[Link back to DTU Orbit](#)

Citation (APA):
Andersen, U. L., Tidemand-Lichtenberg, P., & Buchhave, P. (2004). Squeezing based on nondegenerate frequency doubling internal to a realistic laser. *Physical Review A (Atomic, Molecular and Optical Physics)*, 69(1), 013808. DOI: 10.1103/PhysRevA.69.013908

DTU Library

Technical Information Center of Denmark

General rights

Copyright and moral rights for the publications made accessible in the public portal are retained by the authors and/or other copyright owners and it is a condition of accessing publications that users recognise and abide by the legal requirements associated with these rights.

- Users may download and print one copy of any publication from the public portal for the purpose of private study or research.
- You may not further distribute the material or use it for any profit-making activity or commercial gain
- You may freely distribute the URL identifying the publication in the public portal

If you believe that this document breaches copyright please contact us providing details, and we will remove access to the work immediately and investigate your claim.

Squeezing based on nondegenerate frequency doubling internal to a realistic laser

Ulrik L. Andersen,* Peter Tidemand-Lichtenberg, and Preben Buchhave

Department of Physics, Technical University of Denmark, DK-2800 Kongens Lyngby, Denmark

(Received 10 April 2003; revised manuscript received 12 September 2003; published 15 January 2004)

We investigate theoretically the quantum fluctuations of the fundamental field in the output of a nondegenerate second-harmonic generation process occurring inside a laser cavity. Due to the nondegenerate character of the nonlinear medium, a field orthogonal to the laser field is for some operating conditions independent of the fluctuations produced by the laser medium. We show that this fact may lead to perfect squeezing for a certain polarization mode of the fundamental field. The experimental feasibility of the system is also discussed.

DOI: 10.1103/PhysRevA.69.013808

PACS number(s): 42.50.Dv, 42.50.Lc, 42.65.Ky, 42.55.Ah

I. INTRODUCTION

The generation of manifestly nonclassical states of the light field and, in particular, the Gaussian squeezed state of light is motivated by the great arena of applications, ranging from high-precision measurements with optical sensors [1] to the field of quantum information science [2,3]. The most successful scheme for the production of such states is via intracavity $\chi^{(2)}$ -nonlinear processes where second-harmonic generation of a laser field is followed by a subthreshold optical parametric oscillator [4,5]. Unfortunately, this scheme requires a rather extensive and hence space demanding optical setup. It will therefore appear fruitful to devise some alternative systems which are more compact and consequently more easily integrated into different applications. Towards this aim we investigate, theoretically, the amount of squeezing that can be expected in a certain polarization state of a laser beam using a polarization nondegenerate (type-II) second-harmonic generation (SHG) process which is located inside a laser cavity.

The intensity noise of a standard laser operating well above laser threshold is usually at the quantum noise limit (QNL) provided that the pump source is at the QNL [6]. It is, however, possible to enforce squeezed state production via different means. Regularizing the pumping mechanism, e.g., using a sub-Poissonian pump, may lead to amplitude squeezing at low frequencies of the laser field [7]. This has been shown experimentally for semiconductor lasers, pumped with a sub-Poissonian electrical current [8]. Alternatively, squeezed states can be produced by some mechanisms intrinsic to the laser medium. For example, if the decay rate from the lower lasing level and the pumping rate are matched [9] or if the coherence effect between the pump levels plays a significant role [10], amplitude squeezing is expected to occur. Finally, squeezing effects are anticipated to appear if a nonlinear $\chi^{(2)}$ crystal is placed inside the laser cavity [11–17]. In particular, the system comprising a polarization degenerate (type-I phase-matched) SHG crystal internal to a laser has been investigated theoretically. Fernandez *et al.*

[12] and Levien *et al.* [15] showed that perfect quadrature squeezing may be obtained in the laser field and the up-converted second-harmonic field, respectively, for certain settings of the decay rates involved. A rigorous treatment of the same system was carried out by White *et al.* [16,18]. Contrary to other theoretical investigations, these authors included the effect of very fast dephasing of laser coherence, a practical fact in all common laser systems. They found that the inclusion of this effect leads to additional noise, obscuring the squeezing to the extent that the experiment is not feasible for squeezing production using a type-I SHG crystal. This conclusion has been further corroborated by the fact that squeezing effects from a laser with internal frequency doubling have so far never been observed experimentally.

However, in this paper we show that one should not give up on an up-conversion process internal to a laser as a source of efficiently squeezed light. Rather than incorporating a type-I crystal inside the laser cavity, as done in Ref. [16], we here consider the case of a type-II phase-matched crystal placed inside the cavity. In a type-II SHG process, two fundamental beams along the crystal axes have to be excited. We show that this extra degree of polarization freedom may give rise to very efficient squeezing of a certain polarization state of the fundamental field.

The way of attacking the problem is to derive a set of linearized Langevin equation for the fluctuations of the atomic variables and the fundamental fields (Sec. II) and together with the steady-state values derive the spectrum for the relevant quadratures (Sec. III). In Sec. III we discuss the experimental feasibility and calculate the degree of squeezing that might be expected in a realistic system. Finally, in Sec. IV we conclude this work.

II. LINEARIZED QUANTUM LANGEVIN EQUATIONS

Many different approaches have been developed to characterize the quantum fluctuations of a laser. Here we use a linearized input-output approach in which linearized quantum Langevin equations, derived from the Hamiltonian, are solved directly in Fourier space to yield solutions for the quadrature noise spectra. Details regarding such derivation for a laser system (without a nonlinear crystal) can be found in Ref. [19]. In this section we use this approach to describe a system consisting of a laser crystal and a type-II nonlinear crystal for SHG located inside a common cavity.

*Present address: Institute of Optics, Information and Photonics, Max-Planck Research Group, University of Erlangen-Nürnberg, Staudtstr. 7/B2, D-91058 Erlangen, Germany. Electronic address: andersen@kerr.physik.uni-erlangen.de

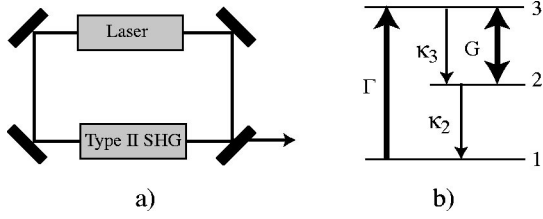

FIG. 1. (a) Schematic setup of the self-frequency-doubling laser. (b) Energy-level scheme of the lasing atoms.

A schematic diagram of the model is shown in Fig. 1(a). The frequency doubling laser consists of a four-level laser crystal (with one of the levels adiabatically eliminated), a type-II nonlinear medium and two orthogonally polarized ring modes; the parallel polarized mode, a_{\parallel} and the orthogonally polarized mode a_{\perp} (see Fig. 2). The former mode constitutes the laser mode as well as one of the fundamental modes of the type-II SHG process. This mode is therefore coupled to the lasing atoms via the coupling strength g and to the nonlinear crystal via the coupling parameter κ . The orthogonally polarized mode also has to be taken into account due to the nondegenerate polarization character of the SHG process. We assume that this mode does not couple directly to the laser medium. This is a good assumption as long as the mode occupies the vacuum state, but it becomes invalid when the mode is intense. However, the implementation of an extra ring cavity, which is coupled to the laser cavity around the SHG crystal, assures that this assumption is valid. We should point out that we consider the system in a basis which is rotated 45° with respect to the basis spanned by the principal axes of the nonlinear crystal [20] as shown in Fig. 2. The reason for this basis shift is to make the intense laser field parallel to one of the fundamental fields and also because, as we will see soon, these polarization directions are particularly interesting.

The Hamiltonian describing the internal mode interaction in the laser and the SHG process is

$$H = i\hbar g (a_{\parallel}^{\dagger} \sigma_{23} - a_{\parallel} \sigma_{23}^{\dagger}) + i \frac{\hbar \kappa}{2} (b a_{\parallel}^{\dagger 2} - b a_{\perp}^{\dagger 2} - \text{H.c.}), \quad (1)$$

where σ_{23} and σ_{23}^{\dagger} are the collective atomic lowering and raising operators between levels 2 and 3. The second-harmonic mode is represented by the annihilation operator b and the creation operator b^{\dagger} . Using the interaction Hamiltonian (1) together with the reservoir Hamiltonian a set of quantum Langevin equations of motion for the internal field

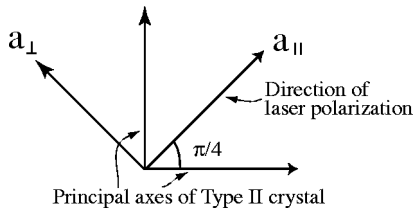

FIG. 2. The principal axes of the nonlinear crystal with respect to the base in which the theory is derived.

operators, the occupation operators, and the coherence operators can be derived directly [19].

We introduce a series of assumptions consistent with most laser systems with intracavity SHG. First, we assume that the decay rate of the second-harmonic field is high; the field escapes the cavity immediately after its generation, enabling an adiabatical elimination from the Langevin equations. Furthermore, we assume that the laser coherence, the pump coherence, the pump cavity, and the upper level decay very rapidly. This enables an adiabatical elimination of the pump mode and the occupation operator of the upper level (see Ref. [19] for details). This results in a three-level laser description as shown in Fig. 1(b).

The steady-state solutions for the atomic populations and the fields are required to evaluate the field spectra. The semiclassical equations of motion are given by

$$\begin{aligned} \frac{d\langle a_{\parallel} \rangle}{dt} &= \frac{G}{2} (\langle \sigma_3 \rangle - \langle \sigma_2 \rangle) \langle a_{\parallel} \rangle - \gamma_{\parallel} \langle a_{\parallel} \rangle \\ &\quad - \mu \langle a_{\parallel} \rangle^* (\langle a_{\parallel} \rangle^2 - \langle a_{\perp} \rangle^2), \\ \frac{d\langle a_{\perp} \rangle}{dt} &= -\gamma_{\perp} \langle a_{\perp} \rangle + \mu \langle a_{\perp} \rangle^* (\langle a_{\parallel} \rangle^2 - \langle a_{\perp} \rangle^2), \\ \frac{d\langle \sigma_1 \rangle}{dt} &= \kappa_2 \langle \sigma_2 \rangle - \Gamma \langle \sigma_1 \rangle, \end{aligned} \quad (2)$$

$$\frac{d\langle \sigma_2 \rangle}{dt} = G (\langle \sigma_3 \rangle - \langle \sigma_2 \rangle) \langle a_{\parallel} \rangle^2 + \kappa_3 \langle \sigma_3 \rangle - \kappa_2 \langle \sigma_2 \rangle,$$

$$\frac{d\langle \sigma_3 \rangle}{dt} = -G (\langle \sigma_3 \rangle - \langle \sigma_2 \rangle) \langle a_{\parallel} \rangle^2 - \kappa_3 \langle \sigma_3 \rangle + \Gamma \langle \sigma_1 \rangle.$$

$\langle \sigma_i \rangle$ is the population of level i scaled by the number of atoms N and $\langle a_n \rangle$ ($n = \perp, \parallel$) are the amplitudes scaled by \sqrt{N} . The total decay rates for the ring modes are γ_{\parallel} and γ_{\perp} , the pump rate is denoted by Γ and the decay rate between levels 3 and 2 (2 and 1) is given by κ_3 (κ_2). G is the stimulated emission rate per photon for the laser mode and the nonlinear coupling parameter is μ , which is proportional to κ^2 .

Homogeneous steady-state solutions are derived by equating Eq. (2) to zero whereby three different solutions are found. The solutions for the internal fields depend on the power level of the beam, pumping the laser process, and can be divided into three regimes as shown in Fig. 3(a). Below threshold for laser action, we naturally have $\langle a_{\perp} \rangle = \langle a_{\parallel} \rangle = 0$ [region (i)]. Above laser threshold one of the field solutions destabilizes associated with the occurrence of the parallel polarized fundamental field, e.g., the laser field [region (ii)]. Another instability, which corresponds to the emergence of the orthogonally polarized fundamental mode, can be reached by increasing the pump power further [region (iii)].

For completeness, the second-harmonic power is shown in Fig. 3(b), and we observe that, due to the back-conversion (associated with the generation of a bright orthogonally polarized mode), the second-harmonic output clamps at a certain value.

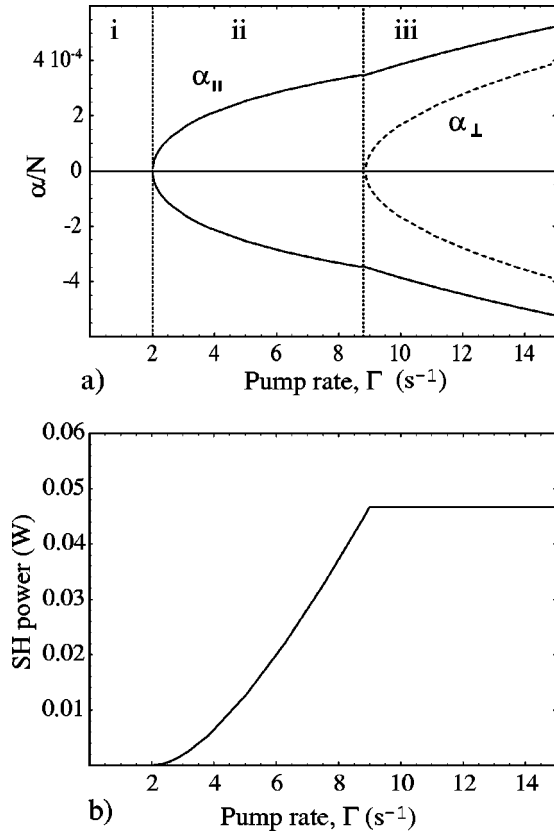

FIG. 3. Steady-state solutions as a function of the pump strength Γ . Solid curve in (a) represents the parallel polarized field amplitude (the laser field) while the dashed curve is the orthogonally polarized mode. (b) The second-harmonic power vs the coupling strength.

To solve for the quantum dynamics we now conduct a linearization approximation by inserting the superpositions

$$w = \langle w \rangle + \delta w, \quad w = (a_{\perp}, a_{\parallel}, \sigma_1, \sigma_2, \sigma_3) \quad (3)$$

into the quantum Langevin equations. We then arrive at the following set of linearized Langevin equations for the quadrature fluctuations of the fundamental fields:

$$\begin{aligned} \frac{d\delta Z_{\parallel}}{dt} &= \Theta G(\delta\sigma_3 - \delta\sigma_2)\langle a_{\parallel} \rangle + 2\sqrt{\mu}\langle a_{\parallel} \rangle \delta Z_b^{in} - 2\mu\langle a_n \rangle^2 \delta Z_{\parallel} \\ &\quad \pm 2\mu\langle a_{\parallel} \rangle \langle a_{\perp} \rangle \delta Z_{\perp} + \sqrt{2\gamma_{\parallel}^c} \delta Z_{\parallel}^{in1} + \sqrt{2\gamma_{\parallel}^c} \delta Z_{\parallel}^{in2} \\ &\quad + \sqrt{G} \delta Z_p, \\ \frac{d\delta Z_{\perp}}{dt} &= -\gamma_{\perp} \delta Z_{\perp} - 2\sqrt{\mu}\langle a_{\perp} \rangle \delta Z_b^{in} + [\pm\mu(\langle a_{\parallel} \rangle^2 - \langle a_{\perp} \rangle^2) \\ &\quad - 2\mu\langle a_{\perp} \rangle^2] \delta Z_{\perp} + 2\mu\langle a_{\perp} \rangle \langle a_{\parallel} \rangle \delta Z_{\parallel} + \sqrt{2\gamma_{\perp}^c} \delta Z_{\perp}^{in1} \\ &\quad + \sqrt{\gamma_{\perp}^c} \delta Z_{\perp}^{in2}, \end{aligned} \quad (4)$$

where the quadrature fluctuation amplitudes, $\delta Z = (\delta X, \delta Y)$, of the fields are defined by $\delta a = \frac{1}{2}(\delta X - i\delta Y)$, where δX and δY represent the amplitude and phase quadra-

tures, respectively. $n = \parallel$ and $n = \perp$ apply to the amplitude and the phase quadrature, respectively. $\Theta = 1$ for the amplitude quadrature while $\Theta = 0$ for the phase quadrature. In both equations the “plus” sign and “minus” sign are associated with the amplitude and phase, respectively. The operators δZ^{in} represent the input fluctuations associated with the various passive loss mechanism while δZ_p is the fluctuations in the laser pump mode. $\delta\sigma_2$ and $\delta\sigma_3$ are fluctuations associated with the atomic populations in the two lasing levels; levels 2 and 3. Finally, the decay rates for the two fundamental fields, γ_n^a and γ_n^l ($n = \perp, \parallel$), are associated with the losses for the cavity mirrors and the other passive losses, respectively.

From the Langevin expressions we see that the quadratures for the parallel polarized mode are, not surprisingly, directly coupled to the laser process. This means that the laser noise adds considerable noise to the parallel polarized mode, which is subsequently transferred into the orthogonally polarized mode. Therefore, we might expect that the laser source has an adverse impact on the production of squeezed light, an expectation also alluded to by White *et al.* [16] for type-I SHG inside a laser cavity. However, we see that in the regime where the orthogonally polarized mode is unexcited, corresponding to region (ii) in Fig. 3(a), i.e., $\langle a_{\perp} \rangle = 0$, the mode decouples from the parallel polarized mode. In turn this means that the laser noise stays in the latter mode and the orthogonal polarization mode evolves independent of the laser mode. Setting $\langle a_{\perp} \rangle = 0$ in the Langevin equation we find

$$\begin{aligned} \frac{d\delta X_{\parallel}}{dt} &= G(\delta\sigma_3 - \delta\sigma_2)\langle a_{\parallel} \rangle + 2\sqrt{\mu}\langle a_{\parallel} \rangle \delta X_b^{in} - 2\mu\langle a_{\parallel} \rangle^2 \delta X_{\parallel} \\ &\quad + \sqrt{2\gamma_{\parallel}^c} \delta X_{\parallel}^{in1} + \sqrt{2\gamma_{\parallel}^c} \delta X_{\parallel}^{in2} + \sqrt{G} \delta X_p, \\ \frac{d\delta Y_{\parallel}}{dt} &= -2\sqrt{\mu}\langle a_{\parallel} \rangle \delta Y_b^{in} + \sqrt{2\gamma_{\parallel}^c} \delta Y_{\parallel}^{in1} + \sqrt{2\gamma_{\parallel}^c} \delta Y_{\parallel}^{in2} \\ &\quad + \sqrt{G} \delta Y_p, \end{aligned} \quad (5)$$

$$\begin{aligned} \frac{d\delta X_{\perp}}{dt} &= -(\gamma_{\perp} - \mu\langle a_{\parallel} \rangle^2) \delta X_{\perp} + \sqrt{2\gamma_{\perp}^c} \delta X_{\perp}^{in1} + \sqrt{2\gamma_{\perp}^c} \delta X_{\perp}^{in2}, \\ \frac{d\delta Y_{\perp}}{dt} &= -(\gamma_{\perp} + \mu\langle a_{\parallel} \rangle^2) \delta Y_{\perp} + \sqrt{2\gamma_{\perp}^c} \delta Y_{\perp}^{in1} + \sqrt{2\gamma_{\perp}^c} \delta Y_{\perp}^{in2}. \end{aligned}$$

Strictly speaking the linearization approximation breaks down when the steady-state solution becomes comparable to the size of its fluctuations. Therefore, in the above-mentioned case where $\langle a_{\perp} \rangle = 0$, the linearization approximation is invalid. However, in a realistic system a small part of the parallel polarized field will always be coupled to the orthogonally polarized wave due to inevitable imperfect alignment of the direction of the laser polarization. In fact, only a few microwatts have to be transferred from the laser polarization to the orthogonal polarization mode to justify the linearization approximation. Due to the vanishingly small amount of light, which is transferred between the two polarization

modes, the seeded light will be at the QNL. Therefore, the asymmetry will not be detrimental to the production of squeezed light.

III. NOISE SPECTRA

Having the linearized Langevin equation for the quadratures at our disposal it is now rather straightforward to evaluate the various noise spectra using well-known techniques.

First we note that since the two orthogonally polarized states are decoupled, the quadratures for the parallel polarized mode [described by the two first evolution equations in Eq. (5)] and the second-harmonics mode mimics that of a singly resonant type-I SHG process located inside a laser cavity. The noise spectra for this system were derived by White *et al.* [16]. They concluded that in an ideal situation where dephasing of the laser coherence could be eliminated, a maximum squeezing of only 50% is reachable at zero frequency. However, they also concluded that in any practical laser system, where realistic values of the laser dephasing noise is taken into account, no squeezing will occur in either the fundamental field or the second-harmonic field.

We now turn to the different feature of our system, namely, the fact that also the orthogonally polarized mode is affected by the nonlinear process. Therefore, we proceed by evaluating the output fluctuations of the orthogonally polarized mode,

$$\delta Y_{\perp}^{out} = \sqrt{2\gamma_{\perp}^c} \delta Y_{\perp} - \delta Y_{\perp}^{in2}, \quad (6)$$

in frequency space, and subsequently derive the quadrature spectrum:

$$V_{\perp}^{\mp}(\omega) = 1 \mp \frac{2\gamma_{\perp}^c [G(\langle\sigma_3\rangle - \langle\sigma_2\rangle) - 2\gamma_{\parallel}]}{\left[\gamma_{\perp} \mp \gamma_{\parallel} \pm \frac{1}{2} G(\langle\sigma_3\rangle - \langle\sigma_2\rangle) \right]^2 + \omega^2}, \quad (7)$$

where the upper signs and the lower signs refer to the phase and amplitude quadratures, respectively. ω is the analyzing frequency and

$$\begin{aligned} \langle\sigma_3\rangle &= \frac{1}{2a}(-b + \sqrt{b^2 - 4ac}), \\ \langle\sigma_2\rangle &= \Gamma \frac{1 - \langle\sigma_3\rangle}{\kappa_2 + \Gamma}, \\ a &= \frac{G^2}{2\mu} \left(1 + \frac{\Gamma}{\Gamma + \kappa_2} \right)^2, \\ b &= \kappa_3 + \kappa_2 \frac{\Gamma}{\Gamma + \kappa_2} - G \left(1 + \frac{\Gamma}{\Gamma + \kappa_2} \right) \left(\frac{G}{\mu} \frac{\Gamma}{\Gamma + \kappa_2} + \frac{\gamma_{\parallel}}{\mu} \right), \\ c &= G \frac{\Gamma}{\Gamma + \kappa_2} \left(\frac{G}{2\mu} \frac{\Gamma}{\Gamma + \kappa_2} + \frac{\gamma_{\parallel}}{\mu} \right) - \kappa_2 \frac{\Gamma}{\Gamma + \kappa_2}. \end{aligned} \quad (8)$$

This corresponds to the steady-state solution indicated by region (ii) in Fig. 3(a).

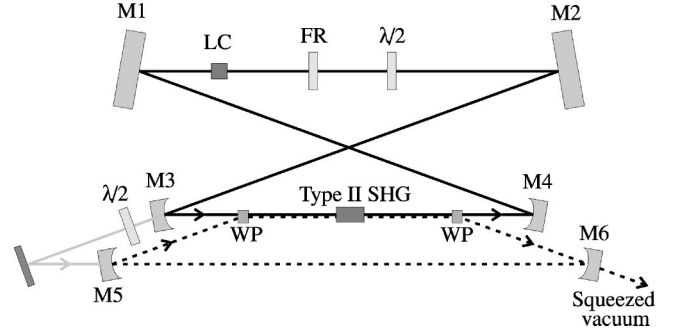

FIG. 4. Schematic of an experimental setup to realize the proposed scheme. The parallel polarized fundamental field (the laser field) resonates between the mirrors M1–M4, while the orthogonally polarized field resonates in a coupled cavity confined by two Wollaston prisms (WP) and the mirrors M5 and M6. A leakage through mirror M3 can be used for locking the coupled cavity to the desired resonance. LC, laser crystal; FR, Faraday rotator and $\lambda/2$, half-wave plate.

We immediately see that the expressions for the spectra (7) resemble the ones for a subthreshold optical parametric oscillator [21]. It is a well-known fact that such a process is capable of producing perfect vacuum squeezing near its oscillation threshold [22] at zero frequency. In our case the phase quadrature is squeezed while the amplitude quadrature is correspondingly antisqueezed. A very important point that can be drawn from these spectra is that like in a subthreshold optical parametric oscillator, the noise of the pump beam (which is very noisy in our case) does not sabotage the degree of squeezing of the orthogonal polarization state.

IV. EXPERIMENTAL CONSIDERATIONS

We now proceed with a discussion of the experimental feasibility of generating squeezed light in the system mentioned above under realistic conditions.

A practical setup has to fulfill a number of important criteria: It is important to maintain low losses at the orthogonally polarized states in order to obtain high squeezing. Both the parallel and orthogonal polarization states have to be kept simultaneously at resonance. It is crucial to make the type-II phase-matched nonlinear crystal work as a full-wave plate to avoid unwanted cross coupling between the two polarization states. Finally beam walkoff has to be eliminated since it introduces cross coupling between the polarization states.

A setup that fulfills the above-mentioned design criteria is shown in Fig. 4. A unidirectional bow-tie ring laser, confined by the mirrors M1–M4, is coupled to a secondary resonator confined by mirrors M5 and M6 and two polarization beam splitters, implemented by, e.g., Wollaston prisms (WP). Wollaston prisms have low insertion losses resulting in low losses in both cavities. The parallel polarized wave circulates in the laser cavity, while the orthogonally polarized wave is confined to the coupled cavity avoiding a passage through the laser crystal.

The cavity containing the laser crystal is a unidirectional ring laser due to the rectification imposed by the combination of the Faraday rotator (FR) and the half-wave plate $\lambda/2$. This

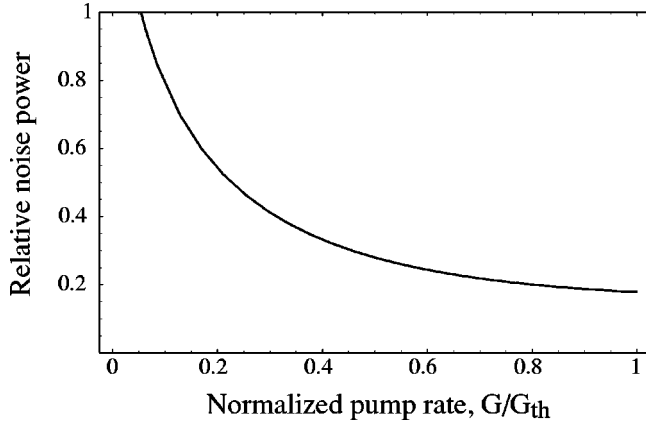

FIG. 5. The phase quadrature noise power of the orthogonally polarized fundamental field as a function of the diode normalized pump rate. $\gamma_{\perp}^c = 1.5 \times 10^7 \text{ s}^{-1}$, $\gamma_{\perp}^l = 0.75 \times 10^6 \text{ s}^{-1}$, $\gamma_{\parallel}^c = 0.5 \times 10^6 \text{ s}^{-1}$, $\gamma_{\parallel}^l = 2.5 \times 10^6 \text{ s}^{-1}$, and $\omega = 4\pi \times 10^6 \text{ s}^{-1}$.

assures a stable, single-frequency laser operation completely avoiding the fluctuations often referred to as “the green problem” [23]. The second coupled cavity must be phase locked to the laser cavity. We suggest a convenient solution where part of the laser field leaking out through mirror M3 is fed into the coupled cavity in the direction opposite to the circulating orthogonally polarized wave. This beam does not disturb the countercirculating orthogonally polarized wave.

A phase-matching scheme without beam walkoff must be chosen in order to avoid direct coupling of the fundamental fields. This is achieved either by choosing a lasing wavelength where noncritical phase matching can be obtained using a type-II crystal, e.g., KTP (potassium titanium oxide phosphate) at 1080 nm [24] or by codoping the nonlinear crystal to match the desired lasing wavelength [25]. Furthermore, careful temperature control should be applied to stabilize the nonlinear crystal as a full-wave plate.

Optimum squeezing in the orthogonally polarized vacuum state occurs at the point of its oscillation, which corresponds to $\langle a_{\parallel} \rangle^2 = \gamma_{\perp} / \mu$. Thus we can estimate the diode pump strength needed to reach the point of instability and hence optimum squeezing. Using realistic values of $\mu = 8.0 \times 10^{-4} \text{ s}^{-1}$ and $\gamma_{\perp} = 1.6 \times 10^7 \text{ s}^{-1}$ we find $\langle a_{\parallel} \rangle^2 = 19.7 \times 10^9$, which again corresponds to a pump rate of 11.1 s^{-1} . This pump rate is readily reached, using, e.g., a diode pumped Nd:YVO₄ laser.

Figure 5 shows the expected degree of squeezing at 2 MHz as a function of the pump rate normalized to the pump rate at the instability point. In calculating this degree of squeezing we have used realistic parameters for the laser medium (e.g., Nd:YVO₄), the cavity, and the nonlinear medium (e.g., KTP). Squeezing at oscillation threshold is given by

$$V = 1 - \frac{4\gamma_{\perp}^c \gamma_{\perp}}{4\gamma_{\perp}^2 + \omega^2}. \quad (9)$$

From this expression and using the parameters mentioned above we estimate that as much as 7.5 dB squeezing at 2 MHz should be observable in a realistic experiment.

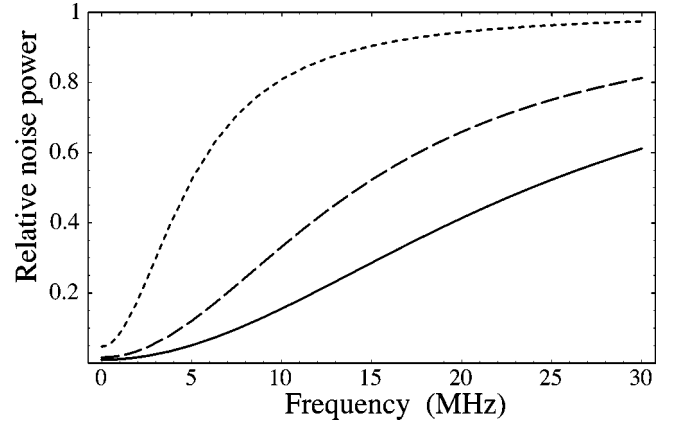

FIG. 6. The phase quadrature noise power of the orthogonally polarized fundamental field as a function of the frequency at three different decay rates for the orthogonally polarized mode. Dotted curve: $\gamma_{\perp}^c = 1.5 \times 10^7 \text{ s}^{-1}$; dashed curve: $\gamma_{\perp}^c = 4.5 \times 10^7 \text{ s}^{-1}$; and solid curve: $\gamma_{\perp}^c = 7.5 \times 10^7 \text{ s}^{-1}$.

In Fig. 6 we plot the noise power (normalized to the shot-noise level) at the oscillation threshold as a function of the measuring frequency for three distinct values of the coupling rate of the orthogonally polarized field. Maximum squeezing is achieved at the impractical zero frequency. However, as clearly seen from the figure, substantial degree of squeezing can also be attained for nonzero frequency. To expand the frequency interval in which squeezing can be obtained the cavity linewidth has to be increased. This, however, will be at the expense of a huge increase in the pump power for reaching the instability point, which is computed to $\Gamma = 11.1 \text{ s}^{-1}$, $\Gamma = 65.6 \text{ s}^{-1}$, and $\Gamma = 165 \text{ s}^{-1}$ for the cases corresponding to the decay rates $\gamma_{\perp}^c = 1.5 \times 10^7 \text{ s}^{-1}$ (dotted curve), $\gamma_{\perp}^c = 4.5 \times 10^7 \text{ s}^{-1}$ (dashed curve), and $\gamma_{\perp}^c = 7.5 \times 10^7 \text{ s}^{-1}$ (solid curve), respectively. Therefore, in order to generate a broadband efficiently squeezed beam, a powerful and efficient pump source for the laser process is needed.

V. CONCLUSION

We have investigated, theoretically, squeezing in a frequency doubler based on a type-II phase-matched nonlinear crystal located inside a laser cavity. The system is resonant for two orthogonal polarization directions of the fundamental field (doubly resonant for the fundamental) while the generated second-harmonic field is allowed to escape freely. Contrary to previously published results concerning type-I frequency doubling, where pump laser noise couples strongly into the quadratures of the generated laser field and subsequently into the generated second-harmonic light, we find that in the regime between the threshold for generation of the parallel polarized fundamental laser field and the threshold for down-conversion into the orthogonally polarized fundamental field it is possible to obtain squeezing in the fundamental field. In fact, we show that the Langevin equation for the phase quadrature of the orthogonally polarized fundamental is identical to the one for subthreshold optical parametric oscillation. Consequently, we claim that our setup can in principle produce perfectly squeezed light in the orthogo-

nally polarized fundamental field near the threshold for down-conversion. We propose an experiment for verification of this idea based on a unidirectional bow-tie laser with a type-II phase-matched second-order nonlinear crystal. The resonance for the orthogonally polarized light is provided by a separate cavity, which is aligned with the laser cavity by

means of polarization dependent components.

We believe the proposed method with carefully aligned components will allow detection of squeezed light from a frequency doubler internal to a laser, a process which has so far not been practical due to different noise sources triggered by the laser process.

-
- [1] V. Giovanetti, S. Lloyd, and L. Maccone, *Nature (London)* **412**, 417 (2001).
- [2] A. Furusawa *et al.*, *Science* **282**, 706 (1998).
- [3] T.C. Ralph, *Phys. Rev. A* **61**, 010303(R) (2000).
- [4] L.-A. Wu, H.J. Kimble, J.L. Hall, and H. Wu, *Phys. Rev. Lett.* **57**, 2520 (1986).
- [5] Breitenbach, T. Müller, S.F. Pereira, J.-Ph. Poizat, S. Schiller, and J. Mlynek, *J. Opt. Soc. Am. B* **12**, 2304 (1995).
- [6] D.F. Walls and G.J. Milburn, *Quantum Optics* (Springer, Berlin, 1995).
- [7] Y. Golubev and I. Sokolov, *Zh. Eksp. Teor. Fiz.* **87**, 408 (1984); Y. Yamamoto, S. Machida, and O. Nilsson, *Phys. Rev. A* **34**, 4025 (1986).
- [8] S. Machida, Y. Yamamoto, and Y. Itaya, *Phys. Rev. Lett.* **58**, 1000 (1987).
- [9] A.M. Khazanov, G.A. Koganov, and E.P. Gordov, *Phys. Rev. A* **42**, 3065 (1990); T.C. Ralph and C.M. Savage, *Opt. Lett.* **16**, 1113 (1991).
- [10] T.C. Ralph and C.M. Savage, *Phys. Rev. A* **44**, 7809 (1991).
- [11] V.N. Gorbachev and E.S. Polzik, *Zh. Eksp. Teor. Fiz.* **96**, 1984 (1989).
- [12] P.G. Fernandez, L.A. Lugiato, F.J. Bermejo, and P. Galatola, *Quantum Opt.* **2**, 49 (1990).
- [13] D.F. Walls, M.J. Collett, and A.S. Lane, *Phys. Rev. A* **42**, 4366 (1990).
- [14] R. Schack, A. Sizmann, and Schenzle, *Phys. Rev. A* **43**, 6030 (1991).
- [15] R.B. Levien, M.J. Collett, and D.F. Walls, *Phys. Rev. A* **47**, 2324 (1993).
- [16] A.G. White, T.C. Ralph, and H.-A. Bachor, *J. Opt. Soc. Am. B* **13**, 1337 (1996).
- [17] J. Zhang, Y. Cheng, T. Zhang, K. Zhang, C. Xie, and K. Peng, *J. Opt. Soc. Am. B* **17**, 1695 (2000).
- [18] A.G. White, T.C. Ralph, and H.-A. Bachor, *J. Mod. Opt.* **44**, 651 (1997).
- [19] T.C. Ralph, C.C. Harb, and H.-A. Bachor, *Phys. Rev. A* **54**, 4359 (1996).
- [20] Z.Y. Ou, *Phys. Rev. A* **49**, 4902 (1994).
- [21] P.D. Drummond, K.J. McNeil, and D.F. Walls, *Opt. Acta* **28**, 211 (1981).
- [22] M.J. Collett and D.F. Walls, *Phys. Rev. A* **32**, 2887 (1985).
- [23] T. Baer, *J. Opt. Soc. Am. B* **3**, 1175 (1986).
- [24] Z.Y. Ou, S.F. Pereira, E.S. Polzik, and H.J. Kimble, *Opt. Lett.* **17**, 640 (1992).
- [25] J. Wang, J. Wei, Y. Liu, X. Yin, X. Hu, Z. Shao, and M. Jiang, *Prog. Cryst. Growth Charact. Mater.* **40**, 3 (2000).