



Compact Solar Combisystem High Efficiency by Minimizing Temperatures

Thür, Alexander; Furbo, Simon

Publication date:
2007

Document Version
Publisher's PDF, also known as Version of record

[Link back to DTU Orbit](#)

Citation (APA):
Thür, A., & Furbo, S. (2007). Compact Solar Combisystem: High Efficiency by Minimizing Temperatures.

DTU Library Technical Information Center of Denmark

General rights

Copyright and moral rights for the publications made accessible in the public portal are retained by the authors and/or other copyright owners and it is a condition of accessing publications that users recognise and abide by the legal requirements associated with these rights.

- Users may download and print one copy of any publication from the public portal for the purpose of private study or research.
- You may not further distribute the material or use it for any profit-making activity or commercial gain
- You may freely distribute the URL identifying the publication in the public portal

If you believe that this document breaches copyright please contact us providing details, and we will remove access to the work immediately and investigate your claim.

Alexander Thür

Compact Solar Combisystem

High Efficiency by Minimizing Temperatures

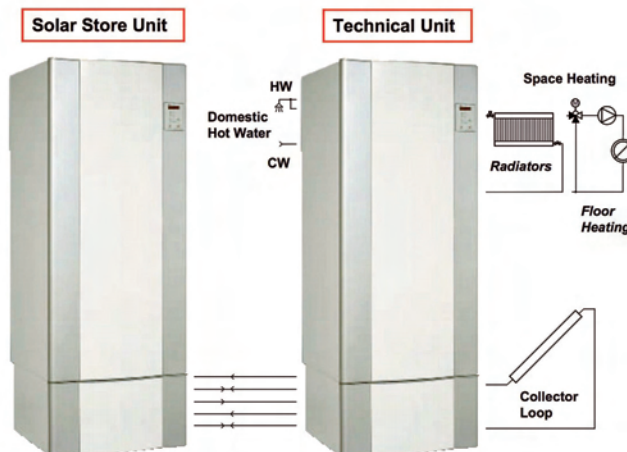
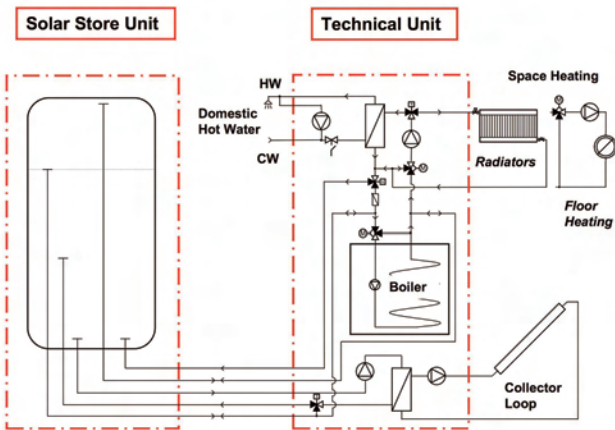
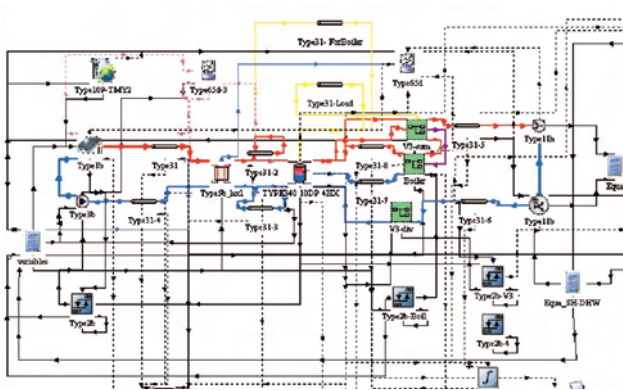

Compact Solar Combisystem

High Efficiency by Minimizing Temperatures

Ph.d.-Thesis

Alexander Thür

BYG•DTU - Department of Civil Engineering

Technical University of Denmark

February 2007

Compact Solar Combisystem - High Efficiency by Minimizing Temperatures

Copyright (c), Alexander Thür, 2007

Printed by DTU-Tryk

Department of Civil Engineering

Technical University of Denmark

ISBN 9-78877-877-2343

ISSN 1601-2917

Preface

This work has been financed by Nordic Energy Research and the Technical University of Denmark and the main industry partner METRO THERM A/S as sponsor of the prototypes.

This thesis is part of the result of the project REBUS – Competitive Solar Heating Systems for Residential Buildings. It was a great honour for me to work within this project and I like to thank all partners for the good co-operation. Naturally, the co-operation with some persons was much closer than others, therefore I like to thank especially the following:

First of all I like to thank my supervisor Simon Furbo, who was available for discussions and support at any time. Further, I like to thank Frank Fiedler who was the main partner for fruitful discussions and exchange of experience, especially during the important period of laboratory tests.

I also like to thank Dan Kristoffersen, Torben Schifter-Holm and their chief Kurt Rasmussen from METRO THERM A/S for the good co-operation. Very special thanks to Frede Schmidt for his great personal effort. He supported the controller development even when being in hospital.

I also like to thank Otto Schäffer and his family for the possibility to get the first experience in practice with the demonstration system in their house. Thank you for almost adopting me in the family and for the perfect support with superb food all the time when I was working in the basement.

I also like to thank for the important contribution from Katrin Zaß, Daniel Barandalla and Anneli Carlqvist, who carried out very valuable master thesis projects within this project.

All my colleagues in the solar group I like to thank for being good and friendly company for the last three years with a lot of interesting and fruitful discussions as well.

The proof readers, Simon Furbo, Anne Rasmussen and Walter Meusburger, I like to thank for the time consuming and great job they did to improve the English of this thesis significantly.

Last but not least, never forget the past. In Austria I also like to thank all my former colleagues at AEE INTEC, where during eight years of joint work I learned the basics about solar heating systems, which was important background knowledge for this work. Further, I like to thank Manfred Oelsch and his family who also gave me the possibility to learn a lot about solar combisystems in practice in their own house.



norden

Nordic Energy Research

Abstract

Compact Solar Combisystem - High Efficiency by Minimizing Temperatures

Alexander Thür

Department of Civil Engineering, Technical University of Denmark

Solar heating systems are getting increasingly popular in many European countries, mainly focused on solar domestic hot water systems. But so-called solar combisystems, which supply heat for both domestic hot water and space heating, are still only really noticeable in Sweden, Germany, Switzerland and Austria. Reasons for that, beside others, might be not sufficiently attractive energy savings, too big space requirement and too much effort and risks for installers due to the complexity of many system concepts and products available on the market.

Based on elaborated knowledge in international research projects within IEA-SHC Task 26 and the ALTENER project “Solar Combisystems”, a new solar combisystem concept was developed. Therefore the focus was concentrated on minimizing the temperature in the system with the goal to reduce system heat losses and to increase the efficiency of the condensing natural gas boiler and the solar collector. The major task was to enable high domestic hot water comfort at any time, independent of the auxiliary set temperature in the solar tank. For a condensing natural gas boiler in combination with a flat plate heat exchanger hot water unit, a hydraulic and control concept could be developed, which ensures the required hot water comfort without the need of high temperature in the solar tank. As a consequence it is possible to use the auxiliary volume in the solar tank at any low temperature level required by the actual space heating demand. This strongly improves the operating conditions for a condensing natural gas boiler and reduces the heat losses of the tank and, most important of all, the pipes within the system.

The compactness of the total hydraulic system, which is installed in a closed 60 x 60 cm cabinet as a technical unit, leads to further reduction of heat losses, the possibility to use heat recovery effects, and several practical advantages like attractive appearance, easy transport and simple and fast installation. Due to the concentration of all technical parts in the technical unit, it is possible to combine it easily with standard tanks of any size in order to achieve the requested energy savings. The hydraulic and control concept was designed to be used with great advantage in combination with condensing natural gas boilers, but it can be also combined with pellet-, wood- or oil boilers just by adjusting some control parameters.

Theoretical investigations including system simulations with TRNSYS showed for this new solar combisystem concept a potential of up to 80% more energy savings compared to existing, conventionally controlled solar combisystems. After development and test of the first prototype in the laboratory, a demonstration system was built which replaced an old conventional natural gas heating system in a one-family house. Measurements in practice showed how this new natural gas - solar heating concept performs in comparison with the old one.

Keywords: Solar Heating, Solar Combisystem, Heat Loss, Efficiency, Condensation

Resumé

Kompakt kombianlæg - Høj effektivitet ved lavere temperaturer

Alexander Thür

BYG•DTU, Danmarks Tekniske Universitet

Solvarmeanlæg bliver mere og mere populære i mange europæiske lande; hovedsagelig solvarmeanlæg til brugsvandsopvarmning. Dog er brugen af solvarmeanlæg til kombineret brugsvands- og rumopvarmning faktisk kun værd at bemærke i Sverige, Tyskland, Schweiz og Østrig. Nogle af grundene til det kunne være: ikke tilstrækkeligt fordelagtige energibesparelser, for stort pladsbehov og for meget besvær, og for store risici for installatører på grund af den kompleksitet der er ved mange anlægskoncepter og produkter på markedet.

Baseret på detaljeret viden om internationale forskningsprojekter inden for IEA-SHC Task 26 og ALTENER projektet "Solvarmeanlæg til kombineret brugsvands- og rumopvarmning", er der udviklet en teknisk unit inklusive en kondenserende naturgaskedel og en lagerunit med solvarmeanlæggets varmelager. Der blev fokuseret på at minimere temperaturen i anlægget med det mål at reducere varmetabene og øge effektiviteten for den kondenserende naturgaskedel og solfangeren. Hovedopgaven var at muliggøre en høj brugsvandskomfort til enhver tid, uafhængigt af temperaturen i solvarmebeholderen. For en kondenserende naturgaskedel kombineret med en pladevarmeveksler til opvarmning af brugsvandet kunne der udvikles et hydraulik- og kontrolkoncept, der sikrer den fornødne varmtvandskomfort uden brug af høj temperatur i solvarmebeholderen. Følgelig er det muligt at bruge det supplerende volumen i solvarmebeholderen på et hvilket som helst lavt temperaturniveau der kræves af rumopvarmningsbehovet. Dette forbedrer driftsbetingelserne for en kondenserende naturgaskedel betydeligt og reducerer varmetabet fra beholderen og, vigtigst af alt, fra anlæggets rør.

Den tekniske unit, som er indbygget i et lukket 60 x 60 cm kabinet har et lavt varmetab, mulighed for at bruge varmegenvinding, flere fordele som attraktivt udseende, nem transport, og enkel og hurtig installation. På grund af koncentrationen af alle tekniske dele i den tekniske unit, er det muligt nemt at kombinere den med standardbeholdere af enhver størrelse for at opnå de ønskede energibesparelser. Konceptet blev konstrueret til med stor fordel at kunne anvendes i kombination med en kondenserende naturgaskedel, men det kan også kombineres med pille-, træ- eller oliefyrbare ved indstilling af nogle kontrolparametre.

Teoretiske undersøgelser, inklusive simuleringer med TRNSYS, viste et potentiale på op til 80% større energibesparelser for dette nye kombianlægskoncept, sammenlignet med eksisterende, konventionelle kombianlæg. Efter at den første prototype var udviklet og afprøvet i laboratoriet, blev der bygget et demonstrationsanlæg der erstattede et gammelt konventionelt naturgasanlæg i et enfamiliehus. Målinger i praksis viste hvordan dette nye naturgas- solvarmekoncept fungerer sammenlignet med det gamle energianlæg.

Stikord: Solvarme, kombianlæg til kombineret rum- og brugsvandsopvarmning, varmetab, effektivitet, kondensation

Kurzfassung

Solar Kombianlage – Effizienz Maximierung durch Temperatur Minimierung

Alexander Thür

Department of Civil Engineering, Technical University of Denmark

Solarthermische Anlagen werden in vielen Europäischen Ländern immer häufiger installiert, insbesondere Solaranlagen zur Warmwasserbereitung. Solaranlagen zur Warmwasserbereitung und Heizungsunterstützung, sogenannte Solare Kombianlagen, haben bisher aber nur in Schweden, Deutschland, der Schweiz und Österreich einen nennenswerten Marktanteil. Mögliche Gründe dafür sind, dass die Energieeinsparung nicht attraktiv genug erscheint, zu hoher Platzbedarf im Haus oder der Aufwand und das Risiko für Installateure ist wegen zu komplexen Systemkonzepten zu groß.

Basierend auf den Erkenntnissen internationaler Forschungsprojekte im Rahmen der IEA-SHC Task 26 und des ALTENER Projektes „Solar Combisystems“ wurde ein neues Konzept für eine solare Kombianlage entwickelt. Bei der Konzeptentwicklung wurde der Schwerpunkt darauf gelegt, die Temperaturen im System zu minimieren, mit dem Ziel die Systemverluste zu reduzieren und die Wirkungsgrade einer Gasbrennwerttherme sowie des Solarkollektors zu steigern. Die wesentliche Herausforderung war, unabhängig von der Temperatur im Solarspeicher und bei gleichzeitiger Einhaltung der Komfortanforderungen, den Warmwasserbedarf zu jeder Zeit decken zu können. Dazu wurde für eine Gasbrennwerttherme in Verbindung mit einer Plattenwärmetauscher-Warmwasserstation ein Hydraulik- und Regelungskonzept entwickelt, welches bei Warmwasserzapfung jederzeit eine ausreichend konstante Warmwassertemperatur sicherstellt. Das Bereitschaftsvolumen im Solarspeicher kann daher von der Gasbrennwerttherme auf dem niedrigeren, im Heizbetrieb gerade notwendigen Temperaturniveau gehalten werden. Dies verbessert deutlich die Betriebsbedingungen für die Gasbrennwerttherme, reduziert die Speicherverluste und besonders auch die Rohrleitungsverluste innerhalb der Kombianlage. Die Kompaktheit der in einem geschlossenen 60 x 60 cm Kabinett eingebauten technischen Einheit reduziert zusätzlich die Wärmeverluste und ermöglicht auch Wärmerückgewinnungseffekte. Weitere Vorteile des vorgefertigten Kabinetts sind einfacher Transport sowie einfache, schnelle und fehlerfreie Installation. Durch die Konzentration aller Einzelkomponenten in dieser technischen Einheit kann diese in einfachster Weise mit Standardspeichern unterschiedlichster Größe für solare Kombianlagen mit beliebigen solaren Deckungsgraden kombiniert werden. Das gesamte Systemkonzept ist derart aufgebaut, dass es besonders effizient in Kombination mit Gasbrennwertthermen mit ausreichender Maximalleistung für die direkte Warmwasserbereitung eingesetzt werden kann. Es kann aber auch in Kombination mit einem Pellet-, Stückholz oder Ölkessel kombiniert werden.

An Hand theoretischer Untersuchungen mit dem Simulationsprogramm TRNSYS konnte gezeigt werden, dass durch dieses neue Regelungskonzept die Energieeinsparung einer solaren Kombianlage gegenüber einem Referenzsystem um bis zu 80 % gesteigert werden kann. Nach erfolgreichen Labortests wurde eine Demonstrationsanlage gebaut und in einem Einfamilienhaus anstatt eines konventionellen Gasheizsystems installiert. Das alte Gasheizsystem sowie die neue solare Kombianlage wurden messtechnisch erfasst und analysiert.

Nomenclature

List of abbreviations used in this thesis:

AC	Alternating current - electric power
COP	Coefficient of performance
COP _{DHW}	Domestic hot water coefficient of performance
DC	Direct current - electric power
DH	District heating
DHW	Domestic hot water
η_{boil}	Boiler efficiency
η_{DHW}	Domestic hot water efficiency
η_{hyd}	Hydraulic efficiency
$F_{\text{sav,therm}}$	Fractional energy savings
GW _{th}	Giga Watt thermal
HDD	Heating degree days
IEA	International Energy Agency
MFH	Multi-family house
NTC	Negative temperature coefficient
PEX	Cross-linked Polyethylene
PUR	Polyurethane
SCS	Solar combisystem
SDHW	Solar domestic hot water system
SF	Solar fraction
SH	Space heating
SHC	Solar Heating and Cooling Program
TRNSYS	Transient Energy System Simulation Tool

Explanations and definitions of the main terms used in this thesis, which are also given in the chapters where the terms are used:

Auxiliary Heat Source	Any other source of heat than solar heat to supply the system; typically this is a boiler or an electric heater.
Auxiliary Volume	The volume that the auxiliary heat source can use as a buffer.
Coefficient of performance	Ratio of (auxiliary final energy consumption) to the (heat load).
Collector Area	Is equal to aperture area in this thesis.
Forward Temperature	The flow with the high temperature within a hydraulic circuit including a heat source and/or a heat sink.
Fractional energy savings	This is the reduction of purchased energy achieved by the use of a solar combisystem, calculated as $1 - (\text{auxiliary energy of the solar combisystem} / \text{auxiliary of a non-solar reference system})$.
Generic System	All described solar combisystem concepts within the IEA-SHC Task26 were called "Generic Systems".
Heat load	Domestic hot water load and space heating load but no hot water circulation heat loss.
Hydraulic efficiency	Ratio of (heat load) to the (total amount of heat put into the heating system).
PID controller	Proportional-integral-derivative controller
Return Temperature	The flow with the low temperature within a hydraulic circuit including a heat source and/or a heat sink.
Solar Combisystem	A solar-plus-supplementary heating system designed to supply heat to both a space heating system and to a domestic hot water system.
Solar fraction	Ratio of (solar heat into the heating system) to the (total amount of heat into the heating system).

Table of Contents

PREFACE	III
ABSTRACT	V
RESUMÉ	VII
KURZFASSUNG	IX
NOMENCLATURE	XI
TABLE OF CONTENTS	XIII
1. INTRODUCTION	1
1.1 OUTLINE	1
1.2 BACKGROUND AND PREVIOUS RESEARCH	2
1.2.1 SOLAR THERMAL ENERGY MARKET AND ENERGY POLICY	2
1.2.2 RECENT RESEARCH RESULTS ON SOLAR COMBISYSTEMS	5
1.3 AIMS AND SCOPE	9
1.4 METHOD	9
2. DESIGN PRINCIPLES FOR A SOLAR COMBISYSTEM	11
2.1 BOUNDARY CONDITIONS FOR THIS PROJECT	12
2.2 CHARACTERISATION OF THE MAIN COMPONENTS	13
2.2.1 SOLAR HEAT SOURCE	13
2.2.2 AUXILIARY HEAT SOURCE	14
2.2.3 DOMESTIC HOT WATER PREPARATION	16
2.2.4 SPACE HEATING	20
2.3 MINIMIZING HEAT LOSSES	22
2.3.1 SOLAR TANK	22
2.3.2 DOMESTIC HOT WATER	23
2.3.3 PIPING AND HYDRAULIC COMPONENTS	25
2.3.4 BOILER HEAT LOSS AND HEAT RECOVERY	26
2.4 MAXIMIZING EFFICIENCY OF BOILER AND SOLAR COLLECTOR	27
2.4.1 CONDENSING NATURAL GAS BOILER	27
2.4.2 SOLAR COLLECTOR CIRCUIT	28
2.5 MAXIMIZING THE UTILIZATION OF STORED HEAT	29
2.5.1 THERMAL STRATIFICATION	29
2.5.2 LOW TEMPERATURE – HIGH POWER CONTROL CONCEPT	31

3. DESCRIPTION OF THE NEW CONCEPT	33
3.1 OPERATION TASKS OF THE SYSTEM	34
3.1.1 DOMESTIC HOT WATER PREPARATION	34
3.1.2 DOMESTIC HOT WATER CIRCULATION	34
3.1.3 SPACE HEATING	34
3.1.4 BOILER AT LOW TEMPERATURE	35
3.1.5 BOILER AT HIGH TEMPERATURE	35
3.1.6 SOLAR HEATING	36
3.2 SOLAR STORE UNIT	36
3.2.1 IMPROVEMENT OF THE STANDARD TANK DESIGN	36
3.2.2 HEAT LOSS COEFFICIENT OF DIFFERENT TANK DESIGNS	38
3.3 TECHNICAL UNIT	41
3.4 POSSIBLE OPTIONS OF THE HYDRAULIC SCHEME	43
4. ANNUAL CALCULATIONS	47
4.1 SYSTEM MODELLING	47
4.1.1 INTERNAL PIPES IN THE TANK	50
4.1.2 PIPING WITHIN THE SOLAR COMBISYSTEM	50
4.1.3 HOT WATER PREPARATION AND SPACE HEATING	51
4.1.4 BOILER INTEGRATION	52
4.2 DIFFERENT BOILER CONTROL STRATEGIES	53
4.2.1 BOUNDARY CONDITIONS FOR THE CALCULATIONS	53
4.2.2 ANNUAL CALCULATION RESULTS	54
4.2.3 CONCLUSIONS	56
4.3 INFLUENCE OF PIPE CONNECTIONS AT THE TANK ON THE ENERGY SAVINGS	57
4.3.1 VALIDATION OF THE TRNSYS MODEL BASED ON LABORATORY EXPERIMENTS	57
4.3.2 DESCRIPTION OF THE SIMULATION MODELS AND THE PARAMETERS	60
4.3.3 SIMULATION RESULTS	62
4.3.4 CONCLUSIONS	67
5. LABORATORY EXPERIMENTS	69
5.1 HYDRAULIC STRATEGIES FOR HOT WATER PREPARATION	71
5.1.1 MIXING VALVE CONTROLS HOT WATER TEMPERATURE	71
5.1.2 STANDARD AC SPEED CONTROLLED PUMP	73
5.1.3 STANDARD DC SPEED CONTROLLED PUMP	74
5.1.4 STANDARD AC PUMP WITH FREQUENCY CONVERTER SPEED CONTROL	75
5.2 DIFFERENT TYPES OF FAST TEMPERATURE SENSORS	77
5.3 CONTROL ALGORITHM FOR HOT WATER PREPARATION	80
5.3.1 HOT WATER WITHOUT BOILER	81
5.3.2 IMPROVED CONTROL OF PUMP SPEED AND MIXING VALVE	83
5.3.3 HOT WATER WITH BOILER START DURING TAPPING	84
5.3.4 HOT WATER WITH BOILER FROM START	86
5.3.5 HOT WATER WITH PREVIOUS OPERATING BOILER FROM START	88
5.3.6 HOT WATER WITH BOILER AND VERY LOW TAP FLOW	89
5.4 BOILER CONDENSATION RATE IN PRACTICE	92

6. DEMONSTRATION HOUSE	95
<hr/>	
6.1 DESCRIPTION OF THE DEMONSTRATION HOUSE	95
6.1.1 THE OLD NATURAL GAS HEATING SYSTEM	98
6.1.2 THE NEW INSTALLED SOLAR COMBISYSTEM	100
6.2 MEASUREMENTS OF THE OLD HEATING SYSTEM	104
6.2.1 DESCRIPTION OF THE MEASUREMENT CONCEPT	105
6.2.2 ENERGY BALANCE OF THE OLD HEATING SYSTEM	107
6.2.3 SPECIFIC DETAILED EVALUATION OF THE OLD HEATING SYSTEM	111
6.3 MEASUREMENTS OF THE NEW SOLAR COMBISYSTEM	114
6.3.1 DESCRIPTION OF THE MEASUREMENT CONCEPT	115
6.3.2 ENERGY BALANCE OF THE NEW SOLAR COMBISYSTEM	117
6.3.3 SPECIFIC DETAILED EVALUATION OF THE NEW SOLAR COMBISYSTEM	121
6.4 COMPARISON OF OLD AND NEW HEATING SYSTEM	130
6.4.1 SPACE HEATING DISTRIBUTION SYSTEM	131
6.4.2 HOT WATER PREPARATION	132
6.4.3 HOT WATER CIRCULATION	133
6.4.4 ELECTRICITY CONSUMPTION	134
6.4.5 KEY EFFICIENCY VALUES	134
6.4.6 ENERGY SAVINGS	139
7. CONCLUSIONS AND SUGGESTIONS FOR FURTHER INVESTIGATIONS	145
<hr/>	
7.1 CONCLUSIONS	145
7.2 SUGGESTIONS FOR FURTHER THEORETICAL INVESTIGATIONS	147
7.3 SUGGESTIONS FOR SYSTEM SIMPLIFICATIONS AND IMPROVEMENTS	148
8. REFERENCES	151
<hr/>	

1. Introduction

This thesis describes the work carried out from 2004 to 2006 at the Department of Civil Engineering, Technical University of Denmark. In this introduction first the outline will briefly be explained, followed by a summary of previous research and background information on this project. Based on this, aims and scope of this thesis will be described and a short description of the method used in this work will close this chapter.

First of all a very basic remark: In general, in this thesis, all energies and efficiencies based on natural gas are based on the lower heating value if not extra defined.

1.1 Outline

This thesis in total has eight chapters with the following content:

- 1) Introduction
The outline is explained, followed by a summary of previous research and background information, aims and scope of the project and the method used to achieve the goals.
- 2) Design Principles for a Solar Combisystem
In this chapter, first the start and boundary conditions for the development of this solar combisystem will be described. After an introduction of the main components of a solar combisystem and their characteristics, the major principles how to design the new concept will be explained.
- 3) Description of the New Concept
First the basic hydraulic scheme will be introduced and the control strategies for all operation tasks will be explained. Further, the two main components “Solar Tank Unit” and “Technical Unit” are characterised and described in detail. Finally some options of additional hydraulic schemes based on the two basic units are described.
- 4) Annual Calculations
The TRNSYS model of this solar combisystem is briefly described, followed by calculation results of a reference system and the new developed system with different system sizes. Further, some theoretical investigations on the influence of some specific parameters on yearly energy savings are presented.
- 5) Laboratory Experiments
The results of the main experiments are described, which were done to find the best components and control strategies for hot water preparation in all situations. Further, the quality of the integration of the condensing natural gas boiler was tested based on measurements of the condensation rate at different operating conditions.
- 6) Demonstration House
This chapter contains the brief description of the demonstration house itself and a detailed description of the old and the new heating system and the measurement concepts for both as well. For both the old and the new system the energy balance on a monthly basis is presented followed by some specific measurement results. A comparison of the old and the new system against each other and against further published measurement results as well concludes this chapter.

7) Conclusions and Suggestions for Further Investigations

A short review is done to summarize the results and the pro's and con's of the concept. Since the process of development and improvement never stops, some suggestions for further work will be done, mainly with the goal to simplify but also to increase the flexibility of the system and to decrease the cost. Finally, some thoughts about the goals which have been achieved or not and conclusions on how things maybe could be improved in similar projects in future will round off this chapter.

8) References

The list of references as they are referred to within the thesis.

1.2 Background and Previous Research

This thesis is dealing with the use of solar thermal energy in buildings. As introduction, first an overview on the worldwide situation is given followed by a summary of some major research results from the recent years, which are used as a basis for this work.

1.2.1 Solar Thermal Energy Market and Energy Policy

Within the framework of the Solar Heating and Cooling Programme (SHC) of the International Energy Agency (IEA) since 2002, each year a study is prepared with the goal to document the worldwide installed solar collector capacity for heat production and to ascertain the contribution of solar heating systems to the supply of energy and the avoided CO₂ emissions (Weiss et.al. 2006). According to this study, in 2004 in 41 countries (3.74 billion inhabitants) a capacity of 98.4 GW_{th} (corresponding to 141 Mio m²) was installed, contributing a heat supply of 58,117 GWh per year and avoiding 25.4 million tons of CO₂. The remarkable market growth rate for this technology between 1999 and 2004 was between 13% in Europe and 25% in China and Taiwan. It is also referred to a study of the Swiss Sarasin bank (Fawer 2005) (see Fig. 1-1), which shows that after wind energy power, solar thermal heat has the worldwide largest contribution of energy production based on renewable energy sources. Solar heating systems are getting increasingly popular in many European countries, but as Table 1-1 shows, there are still big differences in market penetration in different European countries. Actually, public discussions about the energy policy are increasing dramatically in Europe and worldwide as well. At the World Economic Forum 2007 in Davos/Switzerland the dramatic change of the global climate and the need of reducing CO₂ emissions are one of the top discussion themes, which is a big surprise because it is typically a very economically dominated event.

Introduction

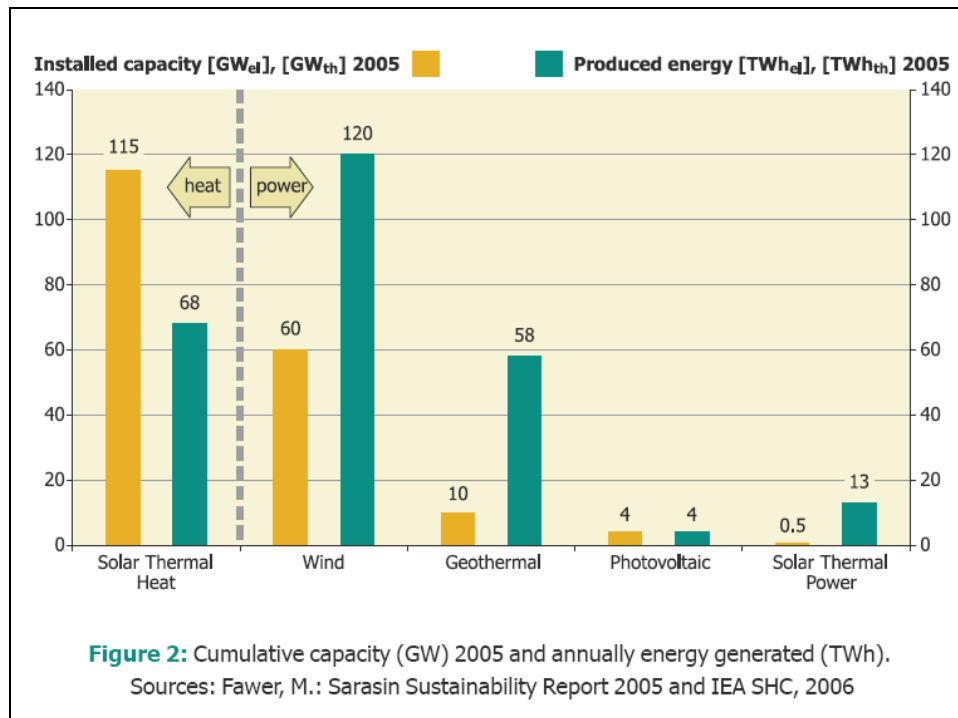

Fig. 1–1 Renewable energy sources worldwide in 2005 (Fawer 2005).

Table 1–1 Market development of glazed flat plate and evacuated tubular collectors in some European countries; installed capacity per year from 1999 until 2004, total capacity in operation in 2004 (absolute and per inhabitant) and the corresponding heat production and CO₂ reduction per year (Weiss et.al. 2006).

		DK	AUT	S	GER	CH	F
Inhabitants	Mio	5.4	8.1	8.9	82.5	7.2	62.0
1999	MW _{th} /a	11	111	9	333	33	22
2000	MW _{th} /a	9	120	15	474	36	29
2001	MW _{th} /a	42	118	44	665	18	43
2002	MW _{th} /a	15	115	13	413	28	43
2003	MW _{th} /a	9	124	17	504	26	68
2004	MW _{th} /a	12	134	20	525	31	82
Total ₂₀₀₄	MW _{th}	215	1527	144	3991	238	484
Total ₂₀₀₄	W _{th} /Inhabitant	40	189	16	48	33	8
Total ₂₀₀₄	GWh/a	106	824	68	2072	115	255
CO ₂ red	t/a	40,711	314,667	24,982	813,380	43,860	101,164

Also the commission of the European Union is discussing the energy policy of the future intensively. But not only global warming is the driving factor since the supply of oil and natural gas from eastern Europe is getting less and less reliable due to increasing political risks. The huge dependency of the European economy and society on fossil fuel from political trustless countries makes clear that the much more important reason for alternative energy sources is to decrease the grade of dependency

dramatically and to raise the degree of self supply. Therefore the use of renewable energies (beside the still existing huge potential of energy savings in Europe) is a must for a sustainable and secure future of the European countries. In that point Sweden is at least a political front runner, since the government has announced the goal to reach 100% independency from fossil fuels until 2020.

As Fig. 1–2 shows, there is a huge gap between the countries Cyprus and Israel and the rest of the world concerning market penetration with solar collectors. Of course the climatic boundary conditions are quite different, but at least Austria as the country No 5 in Fig. 1–2, placed at the “second level”, shows that also in central Europe it is possible to reach a much higher level of solar thermal energy contribution than is the fact in many other countries with similar boundary conditions. But even Austria is still far away from what can be achieved.

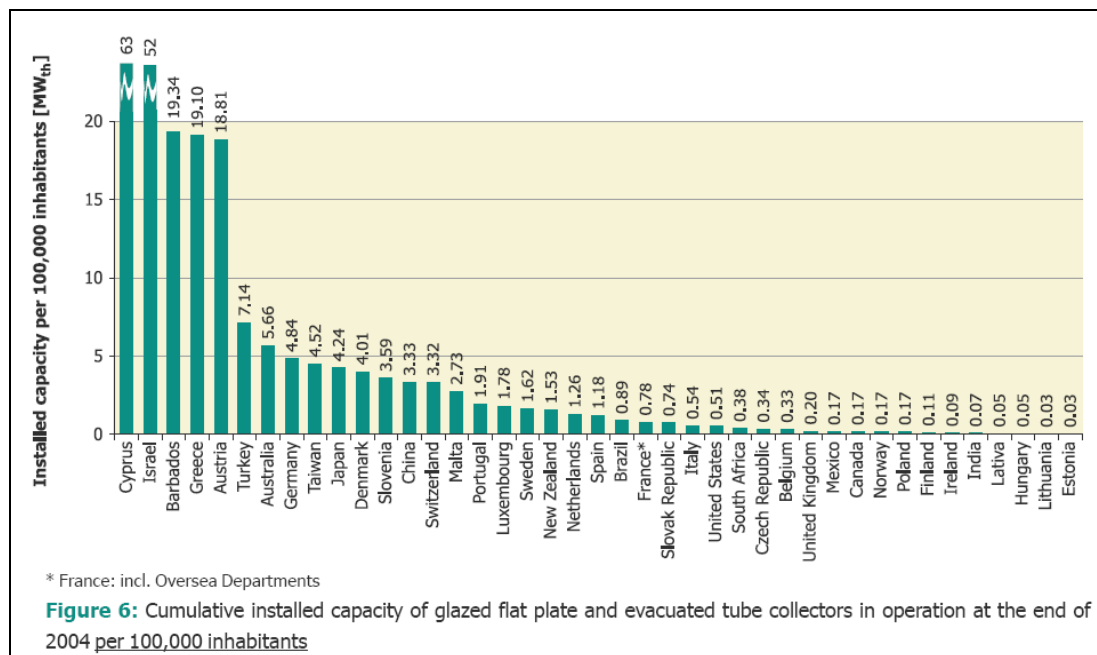

Fig. 1–2 Market penetration in 41 countries per inhabitant in 2004 (Weiss et.al. 2006)

In most countries the market is still focused on solar domestic hot water systems, which are simple and have short pay back times, especially due to good subsidies in some countries. But so-called solar combisystems, which supply heat for both domestic hot water and space heating, are still only really noticeable in Sweden, Germany, Switzerland and Austria, as Table 1–2 shows. Reasons for that, beside others, might be not sufficiently attractive energy savings, too big space requirement and too much effort and risks for installers due to the complexity of many system concepts and products, which are available on the market.

Introduction

Table 1–2 Ratio of installed collector area in 2004 used for solar domestic hot water systems (SDHW), multi family houses and district heating systems (MFH/DH) and solar combisystems (SCS) according to the IEA study (Weiss et.al. 2006).

Country		SDHW	MFH/DH	SCS
DK	%	86	13	1
AUT	%	77	3	20
S	%	10	25	65
GER	%	80	8	12
CH	%	80	5	15
F	%	95	1	4
NL	%	90	8	2
NOR	%	98	1	1
Japan	%	96	2	2

To reduce the obstacles and to increase the market share of solar combisystems, in Scandinavia the project “REBUS – Competitive Solar Heating Systems for Residential Buildings” was started in 2003 with a main financial contribution from Nordic Energy Research. In Fig. 1–3 the network of participants of this project is shown: Technical University of Denmark (DTU), Dalarna University (SERC), University of Oslo (UiO), Riga Technical University (RTU) and Lund Institute of Technology (LIT), as well as the companies: METRO THERM A/S (Denmark), VELUX A/S (Denmark), SOLENTEK AB (Sweden), GRANDEG (Latvia) and SOLARNOR AS (Norway).



norden

Nordic Energy Research

Fig. 1–3 The REBUS – project network, supported by Nordic Energy Research

This PhD-project was done as one out of 4 PhD studies and one post.doc. study in the frame of the REBUS-project.

1.2.2 Recent Research Results on Solar Combisystems

The most important research on solar combisystems most likely was done in the years between 1998 and 2002 in the frame of Task 26 of the International Energy Agency Solar Heating and Cooling Programme (IEA-SHC). The Task 26 involved 35 experts

Introduction

from 9 IEA member countries and 16 solar industries. In total the Task 26 resulted in an impressive number of outputs:

- “Solar Combisystems in Austria, Denmark, Finland, France, Germany, Sweden, Switzerland, the Netherlands and the USA – Overview 2000”, a colored brochure presenting 21 so-called “Generic Systems” which were the most common solar combisystems at that time (Suter et.al. 2000).
- “Solar Heating Systems for Houses – A Design Handbook for Solar Combisystems” (Weiss Ed. 2003).
- Nineteen technical reports
- Proceedings of six industry workshops
- Three Industry Newsletters
- Test facilities in five European countries were included.



Fig. 1–4 On left side the Colored Brochure and right the Design Handbook of the IEA-SHC Task 26

A follow up project of the Task 26 was the ALTENER project “Solar Combisystems” (Ellehaug 2003), which lasted from April 2001 to March 2003. More than 200 solar combisystems in 7 EU countries were installed, documented and theoretically evaluated, and 39 of them were also monitored in detail. The goal of this project was to demonstrate the state of the art of solar combisystems in practice and to be able to compare the measured results with the annual calculations done within Task 26.

From analysing previous research results about solar combisystems and conventional heating systems as well, the main conclusions, of how to achieve high energy savings with a good designed solar combisystem, are:

- High efficiency of the auxiliary heater during operation in practice.
- Low auxiliary set point temperature of the auxiliary volume in the heat storage.
- Small auxiliary volume in the heat storage.
- Compact system design with low heat losses in general.
- Good utilisation of the stored heat which is available in the heat storage.

In Germany the report of a large field test of about 60 heating systems in combination with condensing natural gas boilers in one-family houses was presented (Wolff, et.al. 2004). According to this report, the average annual boiler efficiency of 35 condensing

Introduction

natural gas boilers with an integrated bypass valve (to ensure sufficient high internal flow rate) was 94.6 % compared to 99.0 % (+4.4 %-points) of 23 boilers without such an integrated bypass valve. For 11 boilers placed in a heated room, the average efficiency was 98.4 % compared to 96.3 % of 47 boilers placed in an unheated room. Further, in 15 houses the pre-adjustment valves at the radiators were checked, resulting in the depressing experience that not one of them was set, all valves were totally open.

A difference of 4.4 %-points in average annual boiler efficiency and a natural gas consumption of about 20,000 kWh per year is resulting in 880 kWh difference. To achieve this energy savings a collector area of about 3-4m² in a typical solar combisystem would be necessary.

In addition, in this study the domestic hot water heat demand was investigated. In 22 houses hot water circulation pumps were in operation, resulting in a domestic hot water heat demand of 24.5 kWh/a per m² living area compared to 15.3 kWh/a per m² living area in 25 houses without a circulation pump. In average, this is a difference of about 9 kWh/a per m² living area or 1,500 kWh/a per household (167 m² living area in average). To achieve this energy savings a collector area of about 5-6 m² in a typical solar combisystem would be necessary.

In Denmark a similar test in practice with condensing natural gas boilers in one-family houses was elaborated, but with much less number of systems (Furbo et.al. 2004). For example, the influence of the space heating distribution system on the annual boiler efficiency can be quite large. Two houses had one-pipe systems and two houses had two-pipe systems, which typically causes quite a big difference in the return temperature that can be achieved. The annual boiler efficiency in combination with the one-pipe systems were 93 and 92%, where in the houses with two-pipe systems annual boiler efficiencies of 98 and 97% could be measured. Further, the monthly boiler efficiencies of these four boilers during the summer period without any space heating demand were measured between 77 and 85%.

In a different one-family house, also mentioned in the same report, a very typical problem could also be documented: the start frequency of the burner. In total this burner started 46,307 times within one year, at about 30,000 kWh natural gas consumption. Based on monthly counter results, the daily start frequency in average was between 13 and 246 ignitions per day. The annual boiler efficiency was 96.3 %.

Several theoretical investigations based on annual calculations were done in order to investigate the influence of auxiliary volume and auxiliary set point temperature in solar combisystems.

In Denmark within Task 26 the “Generic system #2” was analysed by Ellehauge (Ellehauge 2002) and the “Generic system #4” by Shah (Shah 2002). The so-called “fractional thermal energy savings” $F_{sav,therm}$, as the savings compared to a reference system for different parameter settings, were calculated.

Ellehauge showed that in a small solar combisystem (280 liter domestic hot water tank volume with gas boiler and 10 m² collector area) for decreasing auxiliary volumes from 126 to 70 liter, $F_{sav,therm}$ increased from 19 to 22%, or plus 16% relative. Shah investigated a medium sized system (750 liter domestic hot water tank volume with gas boiler and 15 m² collector area) where $F_{sav,therm}$ increased from 22 to 26% (plus 18%) if the auxiliary volume is decreased from 375 to 75 liter. Decreasing the domestic hot water set point temperature from 60 to 40°C, in this system resulted in an increase of $F_{sav,therm}$ from 24 to 27% (plus 13%).

Introduction

In Switzerland the “Generic System #8” (830 liter space heating tank volume with integrated gas burner and 12 m² collector area) was analysed by Bony (Bony 2002). Decreasing the burner thermostat set point temperature from 80 to 55°C resulted in an increase of $F_{\text{sav,therm}}$ from 28 to 35%, or plus 25%. In other words, one degree Celcius lower set point temperature increased the savings by about 1% relative.

In Sweden Bales (Bales 2002a) analysed the “Generic System #11” (700 liter space heating tank volume with oil boiler and 10 m² collector area) with the conclusion that a decrease of the auxiliary set point temperature from 80°C to 60°C in this system increases $F_{\text{sav,therm}}$ from 10 to 20%, or plus 100%. The big difference in improvement between the last two systems is most likely due to the different types of auxiliary sources, an integrated natural gas burner and an oil boiler.

An advanced version of “Generic System #11” is “Generic System #12” (700 liter space heating tank volume with gas boiler and 10 m² collector area) which was also investigated (Bales 2002b). $F_{\text{sav,therm}}$ increased from 12 to 17% (plus 42%) if the auxiliary volume was decreased from 350 to 140 liter. Decreasing the auxiliary set point temperature from 75 to 68°C, in this system resulted in an increase of $F_{\text{sav,therm}}$ from 14 to 21% (plus 50%).

Relating to overall system efficiency, very interesting results were reported from a laboratory test at the Swedish National Testing and Research Institute (SP) in Sweden (Kovacs et.al. 1998). Based on 48 hours laboratory test sequences, four solar storage concepts including hot water preparation were tested. The total volume in each system was 1,500 liter, but realized as one, two (2 x 750 liter) or three (3 x 500 liter) store packages. Based on the tests, annual system heat losses between 1,700 and 3,600 kWh were calculated. In other words, the hydraulic system efficiency (without any boiler efficiency) was estimated to be in the range of 78 to 90%. The difference in annual heat losses of 1,900 kWh between the best and the worst system is equivalent to a collector area of about 6-7 m², which would be necessary in a typical solar combisystem to achieve the same energy savings.

The influence and significance of low return temperatures from the space heating circuit, good cooling effect during hot water preparation and good thermal stratification were reported in a study based on calculations done at the Solar Energy Research Center in Sweden (Lorenz et.al. 2000). Base case was a solar combisystem with 750 liter space heating tank volume (240 liter used as auxiliary volume), 10 m² collector area and two immersed heat exchangers for hot water preparation, one in the top and one in the bottom part of the solar tank. The space heating system was designed for 55/45°C at design ambient temperature. The energy savings $F_{\text{sav,therm}}$ of this base case was 20%.

A space heating system designed more advanced like 55/25°C at design ambient temperature was calculated with energy savings $F_{\text{sav,therm}}$ of 22%, or 10% better than the base case. Replacing the immersed heat exchanger for hot water preparation by an external flat plate heat exchanger unit improved $F_{\text{sav,therm}}$ to 23%. With both improvements in the system design, the energy savings $F_{\text{sav,therm}}$ increased to 26%, or 30% more than the base case.

On the other hand, measurements in the laboratory also showed (Andersen et.al. 2005) that external flat plate heat exchanger units for hot water preparation can increase the heat losses significantly. Based on laboratory measurements, the additional heat loss due to an external flat plate heat exchanger unit was reported to be

about 0.76 W/K. The external heat exchanger is mounted directly at the tank and kept warm (at about 40°C) for technical and comfort reasons. The pipes are mounted inside the tank insulation. Therefore, the heat loss coefficient of this investigated tank (460 liter) is increased by about one third from 2.3 W/K to 3.1 W/K due to the external flat plate heat exchanger unit.

The last summary deals with the “Simulation Study of a Dream System” as part of IEA-SHC Task 26 and was elaborated at Solar Energy Research Center in Sweden (Tepe et.al. 2003). Based on “Generic System #11” (700 liter space heating tank volume with oil boiler and 10 m² collector area) with energy savings $F_{\text{sav,therm}}$ of 15.5% several improvements were investigated. A major result was that an improved system concept with an external heat exchanger hot water unit, a 4-way mixing valve for space heating forward flow and a stratifier in the tank for the space heating return flow could achieve almost the same energy savings with a much smaller heat storage volume of 373 liter instead of 700 liter. The energy savings $F_{\text{sav,therm}}$ of the improved but much smaller system were 14.9%, or 4% less.

1.3 Aims and Scope

The aim and scope of this project is simply summarized by the REBUS project title: “Competitive Solar Heating Systems for Residential Buildings”.

To make solar heating systems competitive, in this project the following aims were tried to be achieved:

- Increased energy savings of the solar combisystem by increased system efficiency, especially in combination with condensing natural gas boilers.
- Increased degree of prefabrication shall lead to cost reduction, reduced responsibility of the installer, increased reliability of the installation and increased acceptance by costumers due to high optical attractiveness.
- Flexibility of the system concept to be used for small and large solar fractions, new and retrofit installations with high or low temperature space heating systems and different auxiliary sources like natural gas, oil, pellet or wood boilers.

The major goal was to find a hydraulic and control concept, which in a best way integrates a condensing natural gas boiler leading to highest possible overall system efficiency.

The scope for this solar combisystem in residential buildings is restricted to one family houses (maybe two family houses) due to the limited peak power for hot water preparation. But outside the field of residential buildings, it can also be used in small and medium sized office or industry buildings.

The magnitude of solar fraction is unlimited, since any size of collector area and solar tank volume can be combined with the solar heating unit.

1.4 Method

Based on analysis of previous research results the major characteristics for a high efficient solar combisystem in combination with a condensing natural gas boiler were elaborated theoretically. In a further step, including also the production point of view with major participation of the main industry partner METRO THERM A/S, a prototype was designed and built in the laboratory in order to develop and test the

Introduction

necessary key function of the new system concept. This is the hot water preparation in all situations with and without sufficient temperature in the solar tank. After successful demonstration of this key function, in parallel a simulation model was built up and a demonstration system was built by the main industry partner METRO THERM A/S. Annual calculations were done in order to show the theoretical potential of this concept. The demonstration system was built in order to demonstrate in practice how the developed solar combisystem performs and to determine the energy savings in practice in comparison to the old conventional heating system in the same one-family house.

2. Design Principles for a Solar Combisystem

In this chapter the main components and operation tasks of a solar combisystem are shortly presented and the main characteristics are discussed. Especially new ideas and, from a personal point of view, important thoughts will be focused on, which will be integrated in the new developed system concept. Mainly the thoughts are derived from both previous own experience and of course experiences and results from international research projects, where mainly the IEA-SHC Task26 (Weiss Ed. 2003; Suter et.al. 2000) must be mentioned.

A so-called “solar combisystem” is a heating system with the aim to supply a building with heat for domestic hot water and space heating using two energy sources, the solar energy and any kind of auxiliary heat. As shown in Fig. 2–1 in a very simplified way, a solar combisystem (SCS) in principle consists of the following main parts:

1. Solar collector including collector loop
2. Solar Heat exchanger
3. Heat store
4. Auxiliary heating system
5. Domestic Hot Water preparation (DHW)
6. Space Heating system (SH)
7. Controller

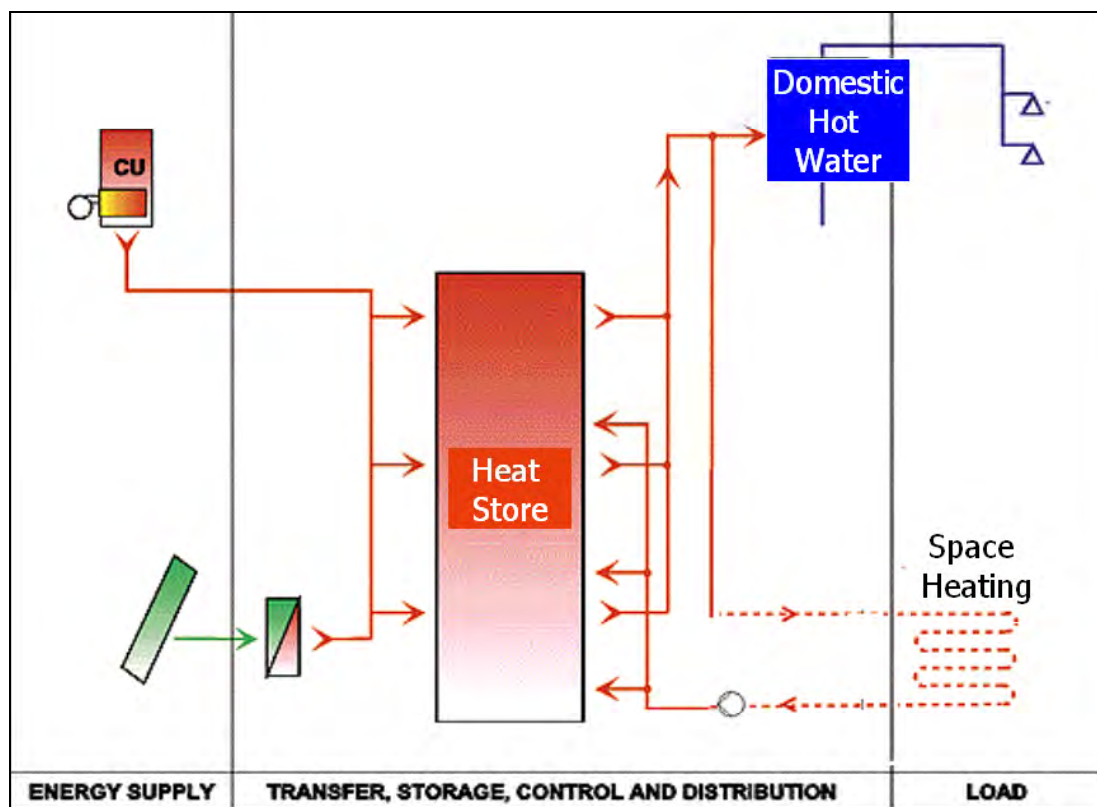

Fig. 2–1 Main parts of a solar combisystem (Suter et.al. 2000)

Design Principles

To replace as much as possible auxiliary energy by using solar energy is the main goal to be achieved. It is the demanding task of the designer to design such a solar combisystem, fitting best to the boundary conditions. Unfortunately, a lot of different boundary conditions have a big influence on the quality, the performance and the efficiency of such a solar combisystem which shall finally satisfy also all expectations of the customer. Such boundary conditions might be:

- Some special kind of available fuel (wood logs for free, low temperature waste heat from a small company, forced to use district heating with special requirements, ...)
- Type of auxiliary heater (fast power changing like a natural gas boiler or very heavy and slow reacting wood log boiler, ...)
- Availability of space in the house for the components (no basement, space only in the attic, ...)
- Type of solar collector (flat plate collector or vacuum tubes)
- Type of space heating system (floor heating, old radiator heating, air heating system in a passive house, ...)
- Heat load of the house (much higher than the available solar power, no space heating demand during sunshine because of high passive solar gain, only on weekends, ...)
- Available subsidies based on specific requirements (based on collector area, based on solar fraction, ...)
- Special kind of domestic hot water demand (only small peaks because of water saving equipment and only taking showers, high peaks because of hot water wasting equipments and taking bathes)
- Weather conditions at the specific place of construction
- Etc., etc., ...

Since all these boundary conditions for one solar combisystem can lead to more or less good performance indicators, it is not possible to design the “best” solar combisystem for all conditions. It is necessary to mark advantages and disadvantages of a specific solar combisystem and the main components related to specific boundary conditions respectively. In most cases, because of any reason, at least one (maybe more) component of the solar combisystem is fixed, which can limit the possibilities of the concept quite strongly. Most times the type of the auxiliary heater is the first component which is fixed, and based on this, and maybe some further restricting factors, the concept can be designed.

2.1 Boundary Conditions for this Project

Also for the REBUS project some main boundary conditions were defined in the contract from the very start:

- Natural gas shall be used as auxiliary heat source in Denmark and Norway; wood pellet shall be used as auxiliary heat source in Sweden and Latvia.
- The solar combisystem shall be able to achieve a solar fraction in the order of 30 to 50% of the annual energy consumption for heat in a building.
- The installation of the solar combisystem shall be possible in both retrofits and new buildings.
- The R&D activities in this project shall focus on:
 - Integration of active solar elements in buildings

Design Principles

- New materials
- Low temperature heating systems
- Optimal control strategies and heat storage technologies
- Optimal interplay between solar and auxiliary energy sources

In the start phase of this project several investigations, surveys and discussions with industry partners on the specific boundary conditions in Denmark were done. Therefore further boundary conditions that are more specific are:

- In Denmark the existing market for solar combisystems is dominated by small solar combisystems with small solar fractions.
- Looking on markets in other countries in Europe, the future market is expected to develop towards more solar combisystems instead of solar domestic hot water systems.
- Houses in Denmark typically have no basements and therefore only very limited space for technical installations in rooms like kitchen, entrance room, laundry room, etc. Space requirement for the solar combisystem should therefore be minimized and the optical appearance should be nice.
- For best possible integration into the furniture, the solar heating system shall consist of 60 x 60 cm cabinets looking like a refrigerator or a freezer.
- High degree of prefabrication shall reduce installation costs and installation failures.
- The system shall be usable for solar combisystems with small and large solar fractions; therefore, small to large heat storages shall be usable.
- Different heat storages from different producer shall be usable.
- The system shall be flexible for different boiler types, both from different producers and for different fuels (natural gas, oil, wood pellet, district heating).
- The system shall be flexible to be used for different space heating systems: high or medium temperature radiator systems or low temperature floor heating systems.

Based on these boundary conditions the concept for the solar combisystem shall be developed. As the next step in the process of system development, it is necessary to analyse the components, which are acting within such a solar combisystem. It is important to understand the operation characteristics of each component in order to use and to control the complete system in the best possible way.

2.2 Characterisation of the Main Components

In order to develop a solar combisystem based on the boundary conditions described before, possible technical solutions for the main components are now described and discussed.

2.2.1 Solar Heat Source

The task of the solar collector is to convert the solar radiation to heat and to transfer this heat to a heat store or directly to a heat sink. For solar combisystems mostly two types of collectors are used, these are flat plate collectors or vacuum tubes.

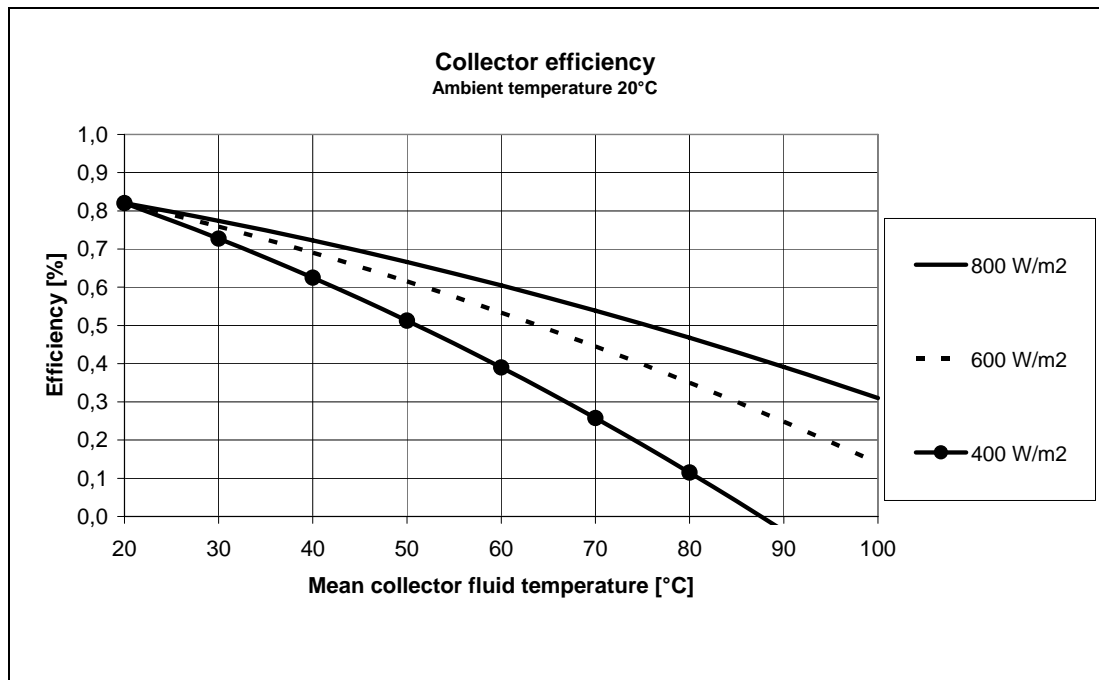

Fig. 2-2 Collector efficiency of a typical flat plate collector at 20°C ambient temperature as a function of solar irradiance and mean collector fluid temperature.

The most important characteristic of a collector is described by the collector efficiency curve, shown in Fig. 2-2, depending on the operating conditions, which are:

- Solar irradiance on the collector
- Ambient temperature
- Mean collector temperature

The first two points are given by the climate and cannot be influenced by the design of the solar combisystem. The mean collector fluid temperature is defined as the mean value of the collector inlet and the collector outlet temperature. This mean collector temperature during operation is strongly influenced by the behavior of the solar combisystem and the space heating system of the house. The solar combisystem should ensure that the return temperature coming to the collector is as low as possible to operate the collector as much as possible on the left side of the diagram. Ten degrees less temperature difference (e.g. mean collector temperature of 50°C instead of 60°C and irradiance of 800 W/m²) increases the collector efficiency in this example by 10% from 61 to 67% (and increasingly more with lower irradiation).

2.2.2 Auxiliary Heat Source

Several different auxiliary heaters are available and they have typically different operating conditions. For example a condensing gas boiler needs in general low operation temperatures, but especially very low return temperatures (<<57°C) for good condensation, which is the basic need for the high efficiencies promised by the manufacturers. A wood boiler on the other hand needs a minimum return temperature (>55°C) in order to avoid condensation and further on deposits and corrosion in the heat exchanger inside the boiler. Different boilers also have different characteristics of how they can be controlled.

Design Principles

Wood pellet and oil boilers nowadays also can modulate within a limited range, but much slower due to high thermal mass. Wood log boilers can typically just be operated in a stop or go modus and simply not be stopped as long as there is wood in the burner. Since in this project a condensing natural gas boiler shall be implemented, now the main characteristics for natural gas and natural gas boiler types are listed:

Natural gas in general:

- Natural gas is one of the most expensive fuels.
- Natural gas is a fossil, not renewable energy source.
- Due to the high content of hydrogen, burning natural gas is producing relatively little CO₂ per kWh compared to other fossil fuels.
- The chimney must be proof against corrosive condensate.
- The chimney can be mounted directly outside the wall (instead of reaching the top of the roof) thanks to the low exhaust temperature and the clean exhaust gases.
- No fuel tank in the house leads to high dependency on the gas grid but saves a lot of space.
- Natural gas is explosive.

Natural gas condensing gas boiler:

- Condensing natural gas boilers can modulate the power within a wide range, typically between 20 and 100%.
- Due to little thermal mass, the standby losses are low.
- Due to the good modulation characteristics, a natural gas boiler can deliver an exact temperature according to the needs given by a controller. If needed, the power is changing very fast in order to keep the set forward temperature.
- Highest boiler efficiency due to condensation is possible, if the system is installed and operated properly.
- Due to a high number of produced units and low material demand, the costs for condensing natural gas boilers are relatively low.
- Efficiency of condensing natural gas boilers is not only a characteristic of the boiler itself, it very strong depends on the operating conditions, like:
 - The dew point of the exhaust gas is in the range of 50 to 57°C, depending on the lambda value the combustion in the gas boiler takes place. To gain the condensation energy, it is needed to cool the exhaust gas below this dew point. Therefore the forward temperature, but much more important, the return temperature must be as low as possible to reach this goal. Because heat transfer demands temperature difference, the water temperature must be well below the dew point.
 - Most of the modern condensing natural gas boilers have internal overpressure bypass valves to ensure a minimum flow rate passing the internal burner heat exchanger. This minimum flow rate is typically in the range of 450 to 600 liter/h, which is much more than the typical flow rate of a radiator heating system most of the time in the heating period. Therefore, the flow rate passing the boiler must be higher than the minimum flow rate in order to avoid internal mixing of the return flow with the forward flow, which would increase the temperature and further on reduce the condensation rate.

2.2.3 Domestic Hot Water Preparation

The domestic hot water preparation is maybe the most variable and therefore most critical part of the whole system; the following characteristics have to be taken into account:

- Fast energy supply is required when hot water is tapped
- Power demand is varying in a wide range (washing hands - filling a bath)
- Highest peak power in the system, up to 30 kW in a one family house
- Fresh water causes various problems like corrosion and lime problems
- Legionella security
- A hot water circulation loop might strongly influence the thermal stratification in the tank
- Constant tap temperature within a very small range is required, e.g. for a shower
- Hot water preparation has the potential to get the lowest return temperature for the collector (cold water temperature is in the range of about 5 to 15°C)

In principle the following solutions are available and typically used to prepare domestic hot water:

1. Separate domestic hot water tank
2. Tank in tank system
3. Internal heat exchanger for domestic hot water preparation
4. External flat plate heat exchanger unit

1. Separate Domestic Hot Water Tank

In Fig. 2–3 a picture shows a possible situation of a large space heating tank and a small hot water tank. The hot water tank (200-300ltr) is typically heated by one or two immersed heat exchangers with heat either from solar collector, from space heating tank or from the boiler. Alternatively, when high hot water power is necessary, also a solution with a flat plate heat exchanger is possible to heat the hot water tank. In principle a lot of hydraulic concepts are possible. Both energy sources - solar collector and boiler - can heat the two tanks either directly, indirectly or even not. Based on this flexibility, a very proper design of the specific system and the used components has to be done and strongly influences the comfort, performance and efficiency of the system.



Fig. 2–3 Solar combisystem with extra domestic hot water tank.

Design Principles

Advantages

- With low temperature space heating systems (floor heating, wall heating) best “thermal stratification” can be achieved between the two very different required temperature levels (space heating loop: 30-35°C and hot water demand: 45-60°C).
- Low return temperature to the collector when the collector loop is also directly connected to the hot water tank.
- Limited lime problems when forward temperature to the hot water heat exchanger is limited to maximum 60°C.
- High hot water peak power on demand side.
- Maintenance and replacing of the hot water tank is easily possible.
- If the boiler is directly heating the auxiliary volume of the hot water tank, the set point temperature for the boiler can be low.

Disadvantages

- Two stores require a high demand of space and piping.
- Hot water tank must be resistant against corrosion.
- Very bad ratio of surface to volume leads to relatively high heat losses.
- A pump is necessary to transfer energy from the one tank to the other.
- Bad cooling effect in the space heating tank during hot water preparation when an immersed heat exchanger only in the top of the hot water tank is used; a concept with a flat plate heat exchanger between space heating tank and hot water tank performs better, but is much more expensive.
- A circulation loop connected to the hot water tank effects very bad thermal stratification in the space heating tank due to the high circulation return temperature.
- Parasitic energy (electricity for the pump) is required for hot water preparation.
- Relatively large volume on temperature level for legionella growth.
- If the boiler is only heating the auxiliary volume of the space heating tank, the boiler set point temperature must be relatively high.

2. Tank in tank

As a step to become more compact the tank in tank concept was developed. The domestic hot water tank (100-200ltr) is integrated in the heat store, as Fig. 2–4 shows.

Advantages

- High peak power on demand side.
- Little effect of the circulation circuit because the circulation return pipe is connected at the right height where the temperatures fit together.
- Lime problems almost impossible; if yes, then only with small effect.
- No parasitic (additional electric) energy for hot water preparation.
- Little space requirement.
- Much smaller hot water volume compared to the hot water tank which strongly reduces the legionella problem in the tank.
- Little heat losses due to the compact design.
- The set point temperature for the boiler can be relatively low.

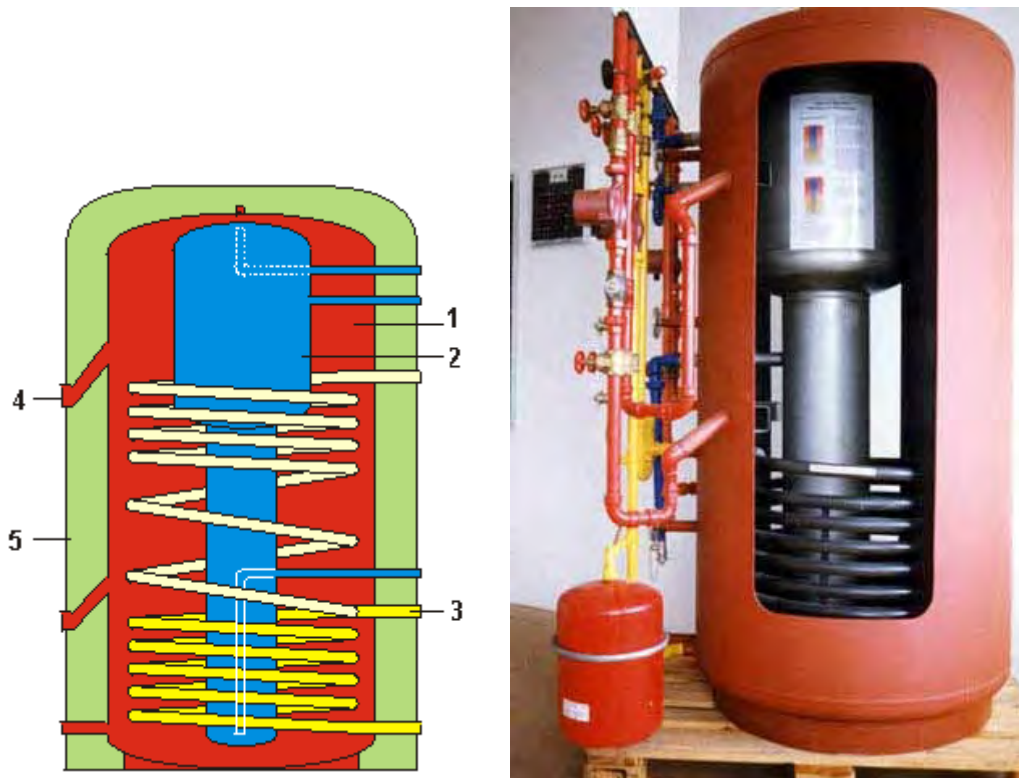

Fig. 2-4 Tank in tank system (Jenni, CH)

Disadvantages

- Depending on details of how the hot water tank is designed (and there are many), medium to worse cooling effect of the heat store.
- Some volume in the lower part is on temperature level for legionella growth.
- Maintenance and replacement is almost impossible, but depends on the tank design.
- The space heating tank in the top part must be heated to hot water set temperature all the time.

3. Internal Heat exchanger for hot water preparation

Mainly to reduce the legionella risk (but also the cost) the tank in tank concept was further developed to a hot water preparation system with immersed heat exchanger (hot water volume: 30-70ltr) shown in Fig. 2-5. Different systems are on the market, mainly differing on how the parts of the heat exchanger are situated in different heights of the heat store.

Advantages

- No parasitic (additional electric) energy for hot water preparation.
- High legionella security because only a very little volume is kept warm.
- Little space requirement.
- Little effect of the circulation circuit because the circulation return pipe is connected at the right height where the temperatures fit together.
- Little heat losses due to the compact design.



Fig. 2-5 Tanks with internal heat exchanger for domestic hot water-preparation (2 figures left: Feuron, CH / right: Solentek, S)

Disadvantages

- Low peak power, therefore depending on comfort requirements, the auxiliary set temperature must be clearly higher than the domestic hot water set temperature.
- Depending on details, bad to worse cooling effect of the heat store.
- Lime problems possible if temperature in heat store exceeds 60°C.
- Maintenance and replacement is almost impossible, depending on the design.
- The space heating tank in the top part must be heated to a higher temperature than hot water set temperature to ensure enough peak power during hot water preparation.

4. Flat plate heat exchanger unit

To prepare domestic hot water in the continuous-flow principle by an external flat plate heat exchanger is the last step of the development to reduce the volume of hot water: only 1-2 Liter in this case.

Advantages

- Peak power is limited, but the power easily can be adapted with the correctly designed heat exchanger, depending on the requirements.
- Good cooling effect in the heat store.
- Best usage of the stored energy in the tank.
- No lime problems when forward temperature is controlled.
- Highest legionella security because almost no volume is kept warm.
- Little space requirement.
- Maintenance and replacement is easily possible.

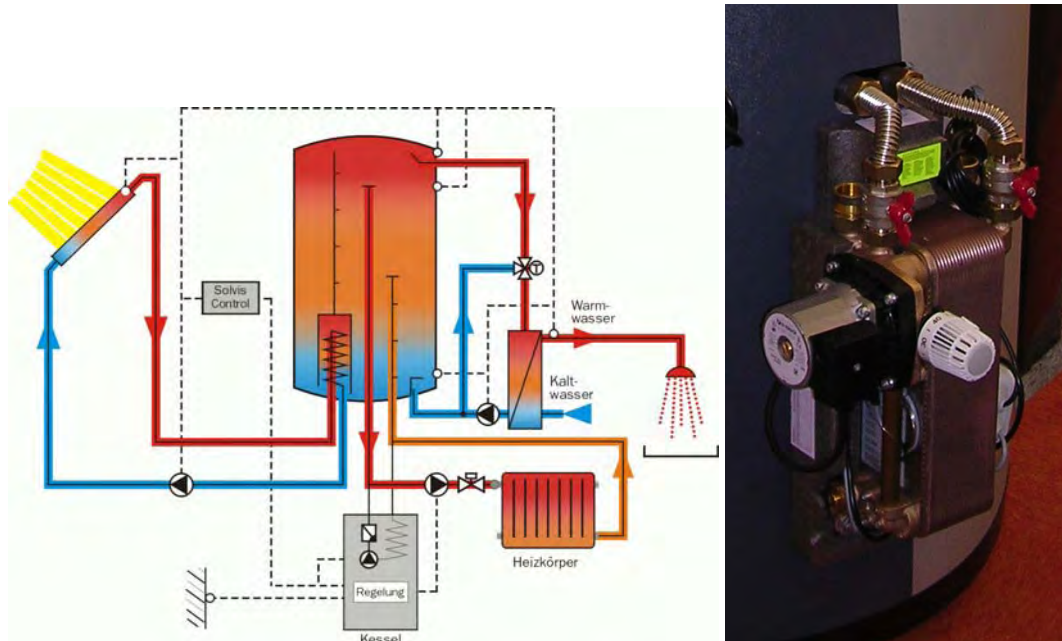

Fig. 2-6 External flat plate heat exchanger unit for domestic hot water (left: SOLVIS, GER / right: Sonnenkraft, AUT)

Disadvantages

- Circulation loop has negative influence on the thermal stratification in the heat store due to high return temperature if no stratification device for the return flow is used in the tank.
- Advanced control system is needed for good behavior of this concept.
- A pump is necessary to run the hot water preparation unit.
- Parasitic energy (electricity for the pump) is required.
- Depending on system design, increased heat losses due to the external installation of the hot water heat exchanger.
- The space heating tank in the top part must be heated to higher temperature than hot water set temperature to enable enough peak power during hot water preparation, if the boiler peak power is not high enough.

2.2.4 Space Heating

The space heating system is typically the largest energy demand over the year in a building (except extreme low energy houses). Also the space heating demand mainly takes place in the winter period with bad operating conditions for the collector: reduced solar radiation and low ambient temperatures. Therefore the space heating system has a large influence on the system behavior, mostly caused by the return temperature:

- Return temperature is depending on the used components like old radiators or new low temperature radiators, wall heating or floor heating systems.
- Return temperature is also depending on the operating conditions, for example if the hydraulic loop is adjusted or not. Also the control strategies like ambient temperature controlled or controlled by thermostatic valves, etc. have a high influence on the return temperature of the space heating loop.

1. High temperature space heating systems

Old radiator systems with design temperatures like 90/70 (very old systems) or 70/50°C (forward/return temperature, for design outdoor temperature) are typically installed in old houses.

Advantage:

- No advantage but easy decision: Do not install a solar combisystem if the heat load of the building is still high. It is possible to invest money more efficient in reducing the energy consumption for the house.

Disadvantage:

- Very high return temperature to the heat store leads to bad operating conditions for the collector.

After thermal insulation of the building the radiators might change to a medium temperature heating system since then the radiators are oversized. Then maybe such a heating system is usable for solar combisystems with low solar fraction and good hydraulic adjustment of the space heating system.

Such systems are also often installed in old houses, which even in summertime often have little space heating demand; in such cases, a solar combisystem can be a good opportunity.

2. Medium temperature space heating systems

In new buildings, radiator systems are typically designed for medium or low temperature operation, like 60/40 or very advanced: 50/25°C (flow/return temperature, for design outdoor temperature).

Advantages:

- Cheap space heating system
- Very low return temperatures are possible, especially in spring and autumn; but only if the radiators are correctly designed AND hydraulically adjusted AND controlled by thermostatic valves (especially 50/25-systems).
- Because of large temperature differences (flow/return) very little mass flow occurs which causes little turbulences in the heat store.

Disadvantage:

- Practical experience shows that in the normal case in existing houses, the return temperatures are very high caused by missing hydraulic adjustments. Especially in heating systems without thermostatic valves where standard valves are manually opened and closed, this is a big problem.

3. Low temperature space heating systems

Floor- or wall heating systems designed for temperature operation like 35/25°C (flow/return temperature, for design outdoor temperature) are in principal the best space heating systems in combination with solar combisystems, because the temperature level in general is very low.

Advantages:

- These systems in general have low return temperatures which leads to good operating conditions for the collector
- Low forward temperatures can easily be reached by the collector even in winter time; therefore the auxiliary heat source can be switched off soon.

Disadvantages:

- Because of little temperature differences (flow/return) very high mass flow might cause strong turbulences in the heat store. This depends on the specific boundary conditions and tank design.
- This type of space heating system is relatively expensive.

2.3 Minimizing Heat Losses

A major requirement for an efficient solar combisystem is to keep the heat losses of the system low. Each kWh heat loss needs to be replaced by more than one kWh energy of the fuel, because the efficiency of the boiler is typically less than one, and some parasitic electricity to run the boiler is needed additionally. Very often it is also possible with a smart design, not only to reduce heat losses, but to reduce the costs as well, like e.g. one meter less installed pipe.

The basic principles are simple:

- Minimizing the surfaces where heat loss can occur.
- For good insulation, beside a low heat transfer rate of the insulation material and sufficient insulation thickness, a perfect fit of the insulation is at least as important in order to avoid thermal bridges and air convection inside the insulation.
- Keep the temperature difference, which is the driving force for the heat loss, as low as possible.
- Keep the heat capacity (therefore the volume) as low as possible, which can cool down to ambient temperature when the system is out of operation.

For the main components the possibilities of minimizing the heat losses now will be discussed more specifically.

2.3.1 Solar Tank

To minimize the surface of a tank, the shape should be a ball. On the other hand, the thermal stratification in a very slim and high tank is best built up and kept. Therefore, it is necessary to find an optimum, which is depending on the operating conditions on how the tank is used. A rule of thumb for cylindrical tanks is a height – diameter ratio of about 3:1. However, typically many other, more practical boundary conditions influence the shape of the tank as well.

The quality of the tank insulation is very strong depending on the thermal bridges. If all pipe connections are placed at the bottom of the tank, it is possible to have a fully closed insulation without any holes and thermal bridges on the side and at the top of the tank. This is especially important in the top part of the tank, where the average temperature is highest. Holes in the tank insulation, which are needed for temperature sensors, can be kept very small and can easily be closed with some insulation material after mounting the sensors.

To keep the heat losses low, it is also important to keep the temperature in the tank low. Low return temperatures from space heating and hot water preparation are therefore essential to minimize the average temperature.

But much more important is the set temperature of the auxiliary volume, which has a big influence on the overall efficiency of a solar combisystem, as it was investigated in the IEA-SHC Task26 project (Shah 2002; Bony 2002; Bales 2002a; Bales 2002b).

Therefore, it is a goal of the system concept, developed within this project, to reduce the auxiliary set temperature as much as possible. Thanks to the fast and powerful natural gas boiler, in this concept the set temperature of the auxiliary volume can be lower than the hot water temperature because the boiler is immediately in operation for hot water preparation. For example in combination with floor heating, the set temperature can be reduced to 35°C. How this can be done will be explained in detail later in chapter 2.5.2 (page 31) and how it works in chapter 5.3 (page 80).

2.3.2 Domestic Hot Water

Beside the quality of insulation of all components used for hot water preparation, a main potential to reduce heat losses and to save energy is how to use hot water. The following points strongly influence the energy consumption, but they strongly depend on the behavior of the consumer:

1. Water saving = energy saving
2. Short time tapping
3. Tap temperature – hot water set temperature
4. Hot water circulation

1) Water saving = energy saving

In mean time water saving equipment is more and more popular. In fact such equipment is reducing the flow rate, mostly by mixing water with air or simply due to an increased resistance in the tap. In most cases of daily life the reasons for tapping hot water is not to fill a certain volume but to wash something under a hot water flow. As long as the washing process with the water saving tap takes the same time it is an advantage to reduce the flow rate and to save water and energy as well. In the case to fill a bath for example, a water saving tap is a disadvantage because it takes more time to fill the bath.

Unfortunately, water saving equipment can also have negative effects:

- Due to the reduced flow rate, the waiting time for hot water at the set temperature increases. Therefore, it is getting more and more popular to install circulation pipes and run circulation pumps, which increase the pipe heat losses dramatically and the electricity consumption a little.
- If the water saving tap is decreasing the flow rate by mixing air to the water, the mixed water-air flow “feels” colder than the water itself before. Consequently, to feel hot water the set temperature of the water is increased in order to compensate for this effect. Therefore, water saving taps, which reduce the flow rate by pressing the water through little holes generating strong, little water jets, might be the better solution from that point of view.

2) Short time tapping

Measurements in practice showed that very short tappings occur quite often. If “one handle mixer” or “thermostat mixer” are installed, it happens very often that the standard position is somewhere in the middle. In such cases, each tapping is also taking some hot water. If such a tapping is quite short, almost no hot water reaches the tap due to the pipe length, but the hot water pipe is filled with hot water, which cools down to ambient temperature again quite fast. In fact in such a case the efficiency is zero: no hot water leaves the tap but energy is used to heat up the pipe. Of course, the higher the hot water set temperature is chosen, the higher is the waste of energy in such cases.

A simple calculated estimation shows the magnitude of this effect: If a hot water pipe with 10 m length and one inch in diameter is filled six times per day with hot water at 60°C and cooling down to ambient temperature of 20°C after the tapping, this is summing up to heat loss of about 300 kWh per year. This is equivalent to more than one month hot water consumption in a typical one family house. If the hot water temperature would be only 40°C, the heat loss would reduce to about 150 kWh per year. If such short tapplings would be done only with cold water, of course the most energy could be saved.

3) Tap temperature – hot water set temperature

As described before the hot water temperature entering the hot water pipes has a quite big influence on the heat losses of the hot water pipes, therefore it should be the goal to reduce the temperature as much as possible. Mainly two arguments are mentioned typically why hot water temperature must be 50 to 60°C: for washing dishes in the kitchen and to prevent the legionella bacteria. Therefore, in conventional installations hot water is heated up to about 60°C (or more) and then again mixed with cold water to get the really wanted temperature. In fact, it is almost impossible to keep hands in water with more than 50°C. Beside washing dishes all needs like washing hands, taking a shower or a bath can be satisfied with about 40°C.

The rate of growth of the legionella bacteria can be kept at an uncritical low level by reducing the volume of water that is kept warm. As described before in chapter 2.2.3 (page 16), a “flat plate heat exchanger unit” for hot water preparation is reducing this volume to about 1 liter. Since this volume of fresh water is replaced several times per day (at e.g. typically 150 Liter per day hot water consumption), there is simply not enough time for the legionella bacteria to grow. Therefore, when such a “flat plate heat exchanger unit” is used, there is no argument any more to heat up hot water to 60°C for legionella prevention. Of course the piping in the house should also be as short as possible and without any dead ends as for example it is the rule in Germany (DVGW W551).

Anyway, this topic is not finally discussed scientifically. Within IEA-SHC Task 26 an extra one day workshop was organized with the main result that there is a big need of research to get serious answers (Warmerdam 2001). At this workshop it could not be reported any study showing that the legionella bacteria is a serious problem. A severe accident in the Netherlands in 1999 was reported at the workshop where 32 people died, but this was due to legionella bacteria which were spread into the air with water vapor for increasing the air humidity at a flower fair.

Now washing dishes with hot water at sufficient high temperature is limiting the potential to reduce the hot water set temperature. If dish washing machines are used the need for washing dishes by hand is reduced significantly. Also the Danish regulations (DS 439) recommend only 45°C for use in the kitchen. Using a “flat plate heat exchanger unit” where the tap temperature is controlled by a controller, a switch in the kitchen could be easy integrated to choose between standard low temperature (e.g. 40°C) and exceptional high temperature (e.g. 45-50°C) for washing dishes. Within this system concept an additional advantage would be that if the low temperature is chosen, the condensing natural gas boiler is able to operate on such a low temperature level that good condensation is possible, which strongly increases the boiler efficiency.

4) Hot water circulation

Depending on the dimensions of hot water pipes (diameter and length) after starting the hot water tapping it takes more or less time until hot water really leaves the tap. During this waiting time, a lot of water is wasted. In order to reduce this waste of water during the waiting time circulation pipes were introduced and they are installed nowadays more and more also in one family houses. Unfortunately, due to this circulation pipes the energy demand for hot water preparation increases dramatically. Circulation heat losses have been measured (Wolff et.al. 2004) which were up to the same magnitude as the hot water consumption itself (or even higher).

In his master thesis, Jens Apel (Apel 2005) investigated different strategies how to operate hot water preparation systems in a one family house based on theoretical simulation studies. A hot water system with 14 m hot water pipes without circulation pipes was compared with several systems where a circulation pipe was controlled according to different strategies. A very advanced control strategy called “circulation on demand” was investigated as well. The control strategy “circulation on demand” means that before e.g. a shower takes place, the circulation pump is switched on by a very short tapping and switched off again when a temperature sensor, which is placed at the start of the circulation return pipe, reached the set temperature. The time the circulation pump needs to run of course is depending on the general boundary conditions and the start conditions. With a flow rate of 5 l/min a 10 m long hot water pipe (one inch diameter) is heated up after about 35 seconds. To take off the clothes before starting the shower typically takes more time.

The main result of this study is that the control concept “circulation on demand” is far the best in all three investigated categories: economy, wasted water and heat losses. The heat loss of the system with “circulation on demand” is only the half compared to the conventional system with a circulation pump running from 6-9, 12-14 and 17-23. Therefore, if it is not possible to install only very short hot water pipes and to avoid circulation pipes, the most efficient operation strategy is “circulation on demand”. Of course for this strategy it is needed that the consumer is accepting this special kind of behavior to activate the circulation pump himself actively.

2.3.3 Piping and Hydraulic Components

A solar combisystem typically is a little more complex than conventional heating systems since more parts (boiler, tank, collector, etc.) are in the system. Therefore, also more pipes are necessary to connect all these parts. Unfortunately, pipes have a very bad ratio of surface to volume and therefore very high heat losses, even when good insulated. Additionally, pipe connections to a tank also cause thermal bridges in the tank insulation and therefore also have a bad influence on the heat loss of the solar tank.

To keep pipe losses as low as possible, the goal is to reduce the number and the length of the pipes and last but not least the temperature of the water inside the pipes. The last one for example can be reached by placing a mixing valve in a way, that the hot pipe is the short one and the warm pipe the long one. In addition, the way how the pipe is used and operated is important. For example the return pipe from hot water heat exchanger to the tank in a good controlled system always has a temperature around the ambient temperature. This pipe simply has no losses and the insulation material can be saved.

Similar but less simple is the case for the space heating return pipe. If the hydraulic circuit for space heating and the radiators are designed, installed and adjusted

properly and the power is controlled in a good way by the flow rate via thermostat valves also the return temperature is very low.

For the decision of the insulation quality that is needed, it is also important to distinguish between pipes with flow over long periods and pipes with flow only during short periods and long periods of no flow. The first type is the space heating circuit, the second is the hot water preparation circuit. In the hot water preparation circuit the hot pipe is used for relative short time and then the flow stops typically for relative long time. If this pipe is good insulated it just takes more time to cool down, but in the end after reaching the ambient temperature the heat loss is the same as no insulation would have been mounted.

The solar collector circuit is a quite special case. Typically, the pipes are from the basement to the roof and therefore quite long and the flow stops at least once per day. In small solar heating systems and if other boundary conditions fit, sometimes it might be a good opportunity to place the solar tank in the attic and therefore to reduce the pipe length dramatically.

But if the tank is placed in the basement, beside good insulation a huge potential typically is the reduction of the pipe diameter. Unfortunately solar collector circuits are very often overdimensioned. A very often used flexible stainless steel pipe is one with 16 mm inner diameter. For collector areas less than 10 m² (as mostly installed in Denmark) and operated according to the low flow principle a pipe with the half diameter would be easily sufficient. The half diameter is resulting in a quarter of volume and therefore also only a quarter of heat loss after switching off the pump in the afternoon.

A simple estimation shows the magnitude of this effect. For a small solar heating system with 30 m total length of the solar circuit this kind of heat loss for a 16 mm pipe is about 0.5 kWh (cooling down from 90°C to 20°C). In the summer period this happens at least 100 times resulting in heat losses of about 50 kWh.

2.3.4 Boiler Heat Loss and Heat Recovery

To keep the boiler temperature as low as possible in coordination with the system concept and the control strategy, is the possibility to keep heat losses low. But especially for small and compact boilers like wall mounted natural gas boilers, the heat loss additionally can be reduced by increasing the ambient temperature. If the natural gas boiler is mounted inside a closed cabinet a kind of extra insulation layer of air is created and the air convection around the boiler is reduced. If inside of this closed cabinet also some other typically bad insulated components like pumps, valves or heat exchangers are mounted, the air temperature inside the cabinet is increased somewhat more and therefore reducing the driving force for the heat loss.

As a last step, a very efficient heat recovery effect of the heat loss of all components inside the cabinet can be realized, if this warm air inside the cabinet is used as preheated combustion air for the boiler.

2.4 Maximizing Efficiency of Boiler and Solar Collector

Beside reducing the heat losses of all components of the solar combisystem it is important to ensure best possible operating conditions for the heat sources which are the boiler and the solar collector to achieve high efficiencies during heat production.

2.4.1 Condensing Natural Gas Boiler

Due to the high content of hydrogen in natural gas, the exhaust gas after combustion consists of quite a big part of steam. Condensing natural gas boilers therefore can increase the heat output significantly. Theoretically, based on the low heating value the boiler efficiency could increase from 100% without condensation to 111% with full condensation. To be able to use this additional potential of heat it is necessary to cool the exhaust gas to less than about 57°C to condensate the steam. Depending on some more specific settings of the burner, this temperature can vary some degrees. In order to achieve a highest possible condensation rate it is necessary to keep the water temperature in the boiler circuit as low as possible for both the forward set temperature and most important for the return temperature.

Standard condensing natural gas boiler for one family houses which are offered on the market, typically have a nominal power between 10 and 40 kW and can modulate the power between 20 and 100 %. For minimizing the production costs and the size and weight of the boiler the water content in most of this kind of boilers is minimized to typically less than 2 liter. To avoid overheating and boiling in parts of the internal heat exchanger therefore an internal bypass valve is used to ensure a minimum flow rate of 400 to 600 liter per hour inside the boiler.

Radiator space heating systems that are installed and adjusted correctly and which are controlled with thermostat valves (especially new radiators) are operating with typical flow rates of 50 to 400 liter per hour.

Comparing the minimum flow rates of the boiler and the flow rates of the space heating system it is clear that the bypass valve of the boiler almost all the time is open. In fact this valve is acting as a mixing valve rising the temperature of the internal boiler return flow.

In Germany, the “University of Applied Science - Braunschweig Wolfenbüttel” carried out long time measurements in practice with in total 67 natural gas boilers (Wolff et.al. 2004). One of the results was that in average the annual boiler efficiency of 35 condensing natural gas boilers with integrated bypass valve was 4 per cent points lower compared to 23 condensing natural gas boilers without an integrated bypass valve. If for example the natural gas consumption for one year is 20,000 kWh, the difference of 4 % is equivalent to 800 kWh, which again is equivalent to the total annual solar gain of about 3 m² collector area.

Therefore, it should be the goal to avoid that such an internal bypass valve in the natural gas boiler is active. If the boiler is not directly connected to the space heating circuit but in parallel also to an auxiliary volume in a tank, the boiler can operate always with the necessary high flow rates. As an additional advantage the number of boiler starts can be reduced significantly in combination with an auxiliary volume in a tank. A reduced number of boiler starts is reducing the start heat losses and the start emissions and rising the life time of the ignition unit of the burner.

In combination with a flat plate heat exchanger unit for hot water preparation (see chapter 2.2.3 page 16) also the average of both the forward and the return temperature

of the boiler can be reduced. Due to the much higher heat transfer rate of the plate heat exchanger compared to an immersed heat exchanger in a hot water tank the forward temperature of the boiler only needs to be about 10 K higher than the hot water set temperature. In conventional heating systems with immersed heat exchanger the forward temperature needs to be 15 to 20 K higher than the hot water set temperature. Depending on the hot water set temperature between 40 and 55°C the boiler can operate with forward temperatures between 50 and 65°C, which is much closer to the condensing temperature of 57°C. Also the return temperature coming from the auxiliary volume in the tank is much lower compared to that from an immersed heat exchanger in a hot water tank. Therefore, in combination with a flat plate heat exchanger unit, during hot water preparation the natural gas boiler is able to condensate, which typically is not the case in combination with hot water tanks and immersed heat exchangers.

If the peak power of the natural gas boiler is high enough to prepare hot water directly, it is possible to operate the system without heating the auxiliary volume up to high temperatures like 60°C, which is needed for hot water preparation. Therefore, the auxiliary volume always can be used with the low set temperatures for space heating, which again is raising the potential of condensation and reducing pipe and tank losses as described earlier.

2.4.2 Solar Collector Circuit

As described in chapter 2.2.1 (page 13) high collector efficiency strongly depends on lowest possible operating temperature. Low return temperature from hot water preparation and space heating is therefore the basic boundary condition.

Depending on the control strategy of the flow rate in the solar collector circuit also the forward temperature can be controlled. It is possible to use one of the three control strategies: “high flow”, “low flow” or “matched flow”.

For the “high flow” strategy the flow rate is adjusted and fixed in a way that, in combination with high irradiation, the forward temperature is about 5-10 K higher than the return temperature. This strategy always keeps the average collector temperature on the lowest temperature level according to the temperature in the bottom of the solar tank.

For the “low flow” strategy the flow rate is adjusted and fixed in a way that, in combination with high irradiation the forward temperature is about 30 K higher than the return temperature. The goal is to reach directly the needed forward temperature as soon as possible and to avoid or at least to delay a start of the auxiliary heat source. With this strategy of course the average collector temperature is much higher compared to the “high flow” principle, in situations where the temperature in the bottom of solar tank is the same.

Unfortunately, it is not as simple as it seems to be. Depending on the kind of system integration, the size of the system, the level of solar fraction that shall be achieved, the characteristic of the heat load and the auxiliary heat source, both control strategies can be of advantage. But several investigations (Andersen et.al. 2006; 2007; Duff Ed. 1996) have shown that in most cases the “low flow” principle, in combination with good thermal stratification in the solar tank, results in higher savings of auxiliary energy. Additionally, due to the “low flow” principle, some further advantages can be achieved: The installation costs are less because smaller pipes and pumps can be used

and the electricity consumption for the pumps is lower. Especially in larger systems with more than about 15 m² collector area, this is a clear advantage.

In combination with speed controlled pumps and a good control algorithm the “matched flow”, as a flexible mix between the “high flow” and the “low flow” principle, gives the best results, if the additional effort for pump and controller is not too big. Especially large systems in combination with district heating are with advantage controlled according to the “matched flow” principle.

2.5 Maximizing the Utilization of Stored Heat

After producing heat with the highest possible efficiency of the boiler and the solar collector and keeping the heat losses as small as possible, it is also important to use the potential of the heat capacity of the heat store in the best way. Since the volume after installation is fixed, only the maximum and the minimum temperatures which occur in the tank can influence the heat capacity. A high heat capacity of the tank has the following effects in the system:

- The start/stop frequency of the boiler is reduced.
- The amount of heat from the solar collector that can be stored in the solar tank is increased.
- Due to high heat capacity based on advanced operation strategy the tank size can be reduced, which also reduces costs and space requirement.

To minimize the temperature in the tank means that the temperature difference between the forward temperature and the return temperature during discharge of the tank should be as large as possible. Therefore, also the process of discharging the tank should take place according to the “low flow” principle with the main goal to achieve lowest possible return temperatures.

Mainly in the period with the potential of strong irradiation and therefore high solar gain, it is important to be able to charge the solar tank as much as possible with solar energy. Therefore, it is also important to minimize the temperature and the volume of the auxiliary volume in the tank as much as possible. Especially for small solar tanks this can have a quite large effect. It is a big difference, if in a 300 liter tank about 100 liter auxiliary volume is kept at a set temperature of 60 to 65°C or not.

If the solar tank is a hot water tank, due to the risk of lime problems very often the controller is set to switch off the solar pump between 60 and 70°C. If the solar tank is a space heating tank, the only limitation is the boiling temperature and the maximum temperature the material of the tank and the insulation can withstand. Therefore, in a typical space heating tank made of steel, temperatures up to 100°C are possible.

2.5.1 Thermal Stratification

In order to achieve the goals of best possible utilization of the energy stored in the tank, one of the most important tasks is to build up and keep good thermal stratification in the tank in the best possible way. The optimum would be, at any time, to have all useful heat stored in the top part just exactly at the set temperature and with a sharp border, the rest of the tank volume should have the lowest temperature occurring in the system. Unfortunately, in reality this is not possible due to several effects.

Design Principles

To build up good thermal stratification means that the inlet flow into the tank enters the tank at the height where the tank temperature is equal to the inlet temperature. To reach this goal, in principle two possibilities are possible:

- A hydraulic device, a so-called stratifier, is used to achieve that the flow enters the tank at the level according where the inlet temperature fits to the tank temperature. Such devices can be different kinds of self acting stratifiers mounted inside or beside the tank. Alternatively, the flow is controlled by switching valves in combination with several pipes connected at the tank in different heights.
- According to few fixed inlets where the temperature in the tank is measured, the inlet temperature is controlled in a way that it fits to the tank temperature. For example, the collector forward flow temperature in combination with a “matched flow” control strategy can be controlled in such a way.

In simulation studies (Andersen et.al. 2006; 2007) of medium sized solar combisystems with 20 m² collector area, 1000 liter solar tank and different total heat loads between about 5,500 and 18,000 kWh per year the influence of theoretical perfect stratifiers on the energy savings was investigated.

For the case of inlet temperatures, due to variable space heating return temperatures, simulations have shown that a perfect inlet stratifier can improve the energy savings by 2 to 6 %. For the case of variable solar forward temperatures due to changing irradiation a perfect inlet stratifier can improve the energy savings by 5 to 8 %. When using perfect inlet stratifiers for both cases in parallel, the calculations showed increased energy savings between 7 and 14 %. The simulations also showed, the higher the space heating load is, the higher the advantage of the stratifier.

If good thermal stratification is built up, it is also important to keep the thermal stratification as good as possible over time.

Thermal stratification can easily be destroyed by turbulences due to badly designed inlets. The inlet flow direction, first of all, should be horizontal and not vertical. Further, the inlet velocity should be very low; less than 0.03 m/s are recommended (Furbo 2004).

Beside a good insulation quality of the tank and no thermal bridges, especially in the hot, top part of the tank, low vertical heat conductivity is essential to keep the thermal stratification. Water itself has a relatively low heat conductivity (0.6 W/mK), but steel has a relatively high heat conductivity (50 W/mK). Therefore, it should be avoided to use steel inside the tank for devices like internal vertical pipes or frames to fix other components. Plastic material with a heat conductivity of only 0.35 W/mK (cross-linked Polyethylene, also called PEX), which can withstand temperatures up to 100°C is much better for such purpose.

As part of a very detailed simulation study on pipe connections at a tank (see chapter 4.3, page 57) (Thür et.al. 2005), it was also investigated how big is the influence of internal pipes (going from the bottom to the desired height) on the thermal stratification in the tank and therefore on the auxiliary demand. The major conclusions were that PEX pipes with 2 mm wall thickness and 20 mm outer diameter, which are used for three internal pipes in the tank, lead to 2.2 % higher auxiliary demand compared to ideal internal pipes. If the wall thickness of the PEX pipes is increased from 2 mm to 8 mm the auxiliary demand is only 1.2 % higher compared to ideal internal pipes (see Fig. 4–12, page 67). The difference of 1 %-point

based on a typical annual heat load of about 20,000 kWh is equivalent to 200 kWh, which again is equivalent to the total annual solar gain of almost 1 m² collector area.

2.5.2 Low Temperature – High Power Control Concept

Good utilization of heat also means that in the best case, heat should be generated exactly at the right temperature and at the time when it is needed. In combination with a fast and powerful condensing natural gas boiler this can be realized. The principle is to use a sufficiently large auxiliary volume as part of the solar tank, which can be used by the boiler to operate at good operating conditions for all conditions during space heating. This means that the boiler can operate at low temperature and at least at the minimum power that can be reached by modulation and is not forced to operate below this minimum power.

High power and high temperature for hot water preparation are produced exactly when hot water is tapped. Therefore, it is not necessary to store heat at high temperature for long time without being used and just generating heat losses.

Summarizing up all the discussed details in this chapter, the goal is to design a system concept, which ensures high efficiency during heat production (solar collector and boiler), good utilization of heat that is available in the heat storage, and finally low heat losses. The next chapter will describe one possibility how such a new developed system concept, based on the specific boundary conditions described in chapter 2.1 (page 12), can look like.

Design Principles

3. Description of the New Concept

Based on the principles which were discussed in chapter 2, the following hydraulic concept was developed. The simplified hydraulic scheme in Fig. 3–1 shows the main components and pipe connections.

The system consists of two units, the “Solar Store Unit” and the “Technical Unit”. The “Solar Store Unit” is, in principle, a buffer tank filled with space heating water which needs to have 5 connections at the right heights. For this “Solar Store Unit” any simple available tank can be used because all advanced devices for optimized operation of the system are integrated in the “Technical Unit”. Of course also more advanced tanks with e.g. stratification devices can be used. The “Technical Unit”, so to say, is the heart of the whole system. In this prefabricated unit all components needed to operate the solar heating system are integrated. Essentially these are the central controller, the condensing natural gas boiler, the domestic hot water flat plate heat exchanger, the solar flat plate heat exchanger, the expansion vessels for the tank and the solar collector loop, as well as several pumps and all necessary mixing and switching valves.

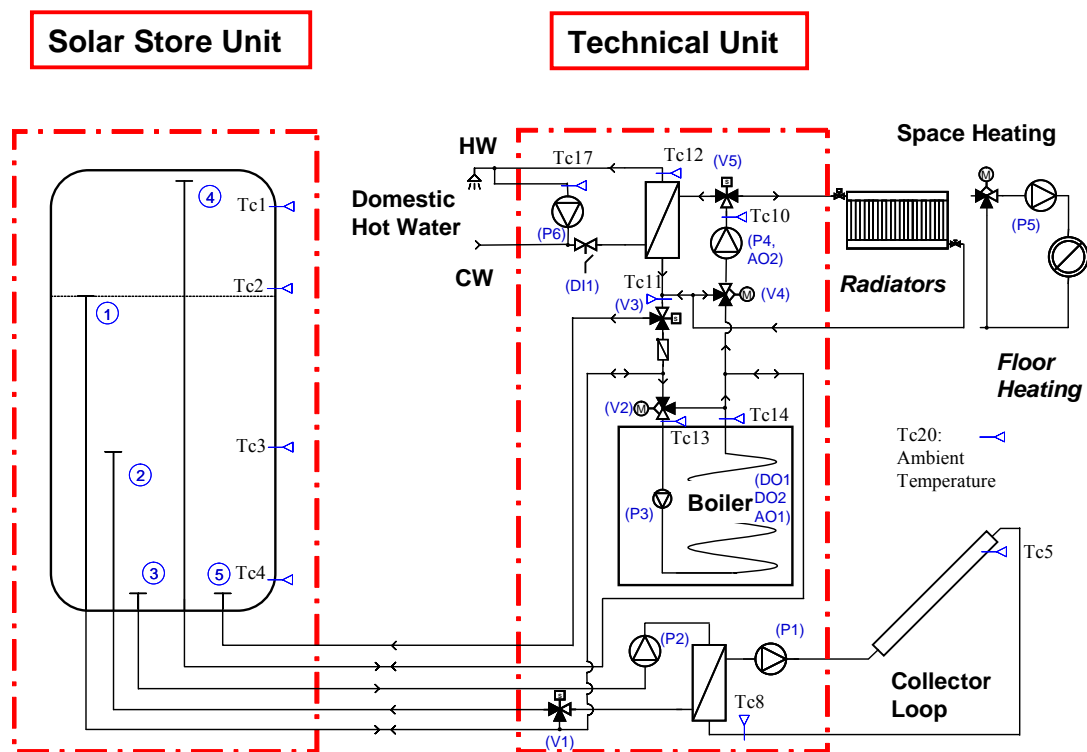

Fig. 3–1 Principle hydraulic scheme of the solar combisystem concept

3.1 Operation Tasks of the System

The operation of the system can be separated in six operation tasks, each of them can either be active alone or two or more can be active in parallel. The six operation tasks are:

1. Domestic hot water preparation
2. Domestic hot water circulation
3. Space heating
4. Boiler at low temperature for space heating
5. Boiler at high temperature for domestic hot water preparation or space heating
6. Solar heating

3.1.1 Domestic Hot Water Preparation

If domestic hot water is used the flow sensor at cold water (CW) inlet activates the domestic hot water preparation. The switching valve (V5) immediately switches to the domestic hot water heat exchanger, the pump (P4) starts running and the mixing valve (V4) controls the primary forward temperature depending on the controller settings. Pump (P4) is speed controlled in a way that the hot water (HW) temperature is kept constantly at the set temperature. Both the pump (P4) and the mixing valve (V4) are controlled by a PID controller which is integrated in the central system controller. Hot water is taken from the highest point in the tank (pipe 4) passing the mixing valve (V4), the pump (P4) and the switching valve (V5) to enter the domestic hot water heat exchanger. After the heat exchanger, the cold water is stratified into the tank by the valve (V3) via pipe 5 or via pipe 1, depending on the return temperature and the actual temperature stratification in the tank.

In the controller, it is possible to define the set temperature for the tap hot water (HW). Furthermore the temperature difference can be defined which the hot water temperature at the primary side of the heat exchanger (Tc10) shall be higher than the tap hot water temperature (Tc12).

3.1.2 Domestic Hot Water Circulation

In general, the domestic hot water circulation pump (P6) can be activated by several time windows which can be defined in the controller. Two different operation modes are possible:

1. The domestic hot water pipes are kept warm within defined time windows.
2. Hot water circulation on demand.

The first strategy starts the hot water circulation pump (P6) if the circulation temperature decreases below a set start temperature and stops when the circulation temperature increases above a set stop temperature.

The second strategy starts the hot water circulation pump (P6) when the flow sensor indicates hot water tapping. Therefore, with a short opening of any tap valve in the house the circulation pump is started. If the circulation temperature increases above a set stop temperature, the circulation pump stops after a defined additional delay time.

3.1.3 Space Heating

Space heating can be switched on or off in the controller by a parameter or activated automatically if ambient temperature or the measured room temperature is below a set

value. The space heating forward temperature is controlled via a so-called “heating curve” depending on the ambient temperature. This heating curve can be defined in the controller. During space heating operation, the speed of the pump (P4) is constant and can be defined as a parameter in the controller. The actual flow rate is controlled by thermostatic valves and/or pre-adjusting valves in the space heating system.

Hot water is taken from the highest point in the tank (pipe 4) passing the mixing valve (V4), the pump (P4) and the switching valve (V5) to enter the space heating system. Depending on the return temperature after the radiators or after the floor/wall heating and on the actual temperature stratification in the tank, the cold water is stratified into the tank by the valve (V3) via pipe 5 or via pipe 1.

3.1.4 Boiler at Low Temperature

Condensing natural gas boilers typically have two hydraulic connections in combination with two operation modes, the space heating mode and the domestic hot water preparation mode. Space heating mode is typically activated by a room thermostat, and the domestic hot water preparation mode is controlled by a temperature sensor in the hot water tank. In this case the central controller is controlling the two inputs of the gas boiler controller instead of connecting a room thermostat and a hot water temperature sensor.

If during space heating the temperature in the top of the tank (pipe 4) is not high enough the boiler is activated. If the demanded space heating forward temperature (depending on the heating curve) is below a defined set temperature, the boiler is allowed to operate at the low temperature level (typically between 40 and 50°C) in the space heating mode. This gives the condensing natural gas boiler good operation conditions for condensation since the dew point of the exhaust gas is about 57°C.

Cold water is taken out of the tank via pipe 1, passing the mixing valve (V2) and entering the boiler. The hot water coming out of the boiler is stratified into the tank via the highest inlet, which is pipe 4. In parallel, hot water coming out of the boiler is directly used for space heating with the demanded flow rate. Since the boiler always has a higher flow rate than space heating, the auxiliary volume in the tank (volume between pipe 4 and pipe 1) is heated up. If the temperature at the level of pipe 1 approaches the switch off set temperature, the boiler is switched off.

Due to this concept of parallel flows, several advantages are achieved. The boiler is not forced to operate below its minimum flow rate, which ensures that an internal bypass valve (which exists in most condensing natural gas boilers) remains closed and therefore the return temperature is not raised, which would reduce the condensation rate. Furthermore, due to the possibility of using the auxiliary volume the boiler is not forced to operate below its minimum power, which the boiler can achieve by modulation. This heavily reduces the start/stop frequency and therefore also raises the boiler efficiency and reduces the exhaust gas emissions.

3.1.5 Boiler at High Temperature

If during domestic hot water preparation the temperature in the top of the tank (pipe 4) is not high enough the boiler also is activated, but this time at high temperature level in domestic hot water mode, which is needed to be able to prepare domestic hot water at the desired tap temperature. Since the tap temperature is

typically between 45 and 55°C, the boiler set temperature at high temperature level must be about 55 to 65°C.

If during space heating the demanded space heating forward temperature (depending on the heating curve) is above a defined set temperature the boiler is also forced to operate at the high temperature level in the domestic hot water mode.

Due to the high boiler forward temperature it could be expected, that the condensation rate of the natural gas boiler is very low. But thanks to the high flow rate and the very low return temperature during hot water preparation, also in this high temperature operation mode good condensation can mostly be achieved.

3.1.6 Solar Heating

If the temperature sensor in the solar collector exceeds the temperature in the bottom of the tank, the primary solar pump (P1) starts running. When the primary solar forward temperature at the inlet of the solar heat exchanger is also high enough, the secondary solar pump (P2) starts. Cold water is taken from the tank via pipe 3 and depending on the existing temperature stratification in the tank the solar heated water is stratified back into the tank by the switching valve (V1) via pipe 2 or via pipe 1.

3.2 Solar Store Unit

This solar store unit was developed based on the 300 liter standard domestic hot water tank from Metro Therm A/S. The tank is integrated in a 60 x 60 cm cabinet with a nice casing which is perfect for optical integration. The standard tank is insulated with PUR-foam which is filled between the tank with a diameter of 500 mm and the 60 x 60 cm cabinet. Consequently, the minimum insulation thickness is 50 mm. At the top of the tank the insulation thickness is also about 50 mm. All pipe connections are placed at the bottom of the tank, using internal PEX pipes to reach the different levels in the tank. Only small holes in the insulation at the top of the tank are needed to mount the temperature sensors. These holes reduce the insulation quality only very little, because the two thin cables are just marginal thermal bridges.

According to Metro Therm A/S the overall heat loss coefficient of this standard tank is about 1.9 W/K.

3.2.1 Improvement of the Standard Tank Design

In order to improve the standard tank to be usable in a solar combisystem, several changes in the tank design were done:

The volume of about 300 liter for a solar combisystem, even a small one, is too little. To increase the volume but still to keep the 60 x 60 cm concept, a new combined insulation concept was developed to be able to increase the diameter of the tank. Using 20 mm thick vacuum panels which are integrated into the PUR foam allows to increase the diameter of the tank by 10% (550 mm instead of 500 mm). This increases the volume by 20% (360 liter instead of 300 liter) but enables about the same heat loss coefficient. Detailed investigations on the heat loss coefficient are presented in chapter 3.2.2.

Description of the New Concept



Fig. 3-2 Left: View of the top of the tank with vacuum panels at the sides and the 2 small holes for the temperature sensors in the middle of the tank; Right: View of front of the tank without the cover plate to see one of the vacuum panels.

Since the tank is filled with space heating water instead of fresh water, to reduce costs, it is possible to cancel the internal enamel protection layer, which normally exists in the standard tanks.

All pipe connections are at the bottom of the tank. PEX pipes with 16 mm inner diameter and 20 mm outer diameter that fit exactly into the $\frac{3}{4}$ inch steel pipes (which are welded into the bottom of the tank) are used to reach to the right level in the tank. Investigations (see chapter 4.3, page 57) showed that the pipe wall thickness of 2 mm should be enlarged to reduce the heat transfer coefficient between the tank water and the water inside the PEX pipe to minimize unintentional heat transfer which would have several negative effects. For that reason a second PEX pipe with 22 mm inner diameter and 32 mm outer diameter is used for additional insulation for the long pipes (pipe 1 and pipe 4) which reach the top part of the tank.



Fig. 3-3 Prototype example showing a thin PEX pipe (with holes at the end) with an additional thick PEX pipe to decrease the heat transfer coefficient.

A drawing of the tank is shown in Fig. 3-4. Pipe 1 and pipe 4 have this additional thick PEX pipe. Pipe 1 is closed at the end to prevent vertical flow into the tank which could cause strong turbulences. Water can enter or leave the tank through the holes which are drilled radially into the PEX pipe. Pipe 4 has a T-piece at the end in order to have low and horizontal inlet velocity when water is entering the tank. This

Description of the New Concept

guarantees good thermal stratification. Pipe 2 is only a thin PEX pipe, again with radially drilled holes. Pipe 3 has no PEX pipe, it is just the $\frac{3}{4}$ inch steel pipe which is welded into the bottom part of the tank. Pipe 3 is only used to take out water from the tank to be heated by the solar collector. Pipe 5 is the low temperature inlet pipe which also has a T-piece in order to guarantee good thermal stratification when cold water enters the tank. During hot water preparation, this inlet pipe 5 can have the highest inlet flow rate of all pipes which typically can take place. For this reason the T-piece here is very important.

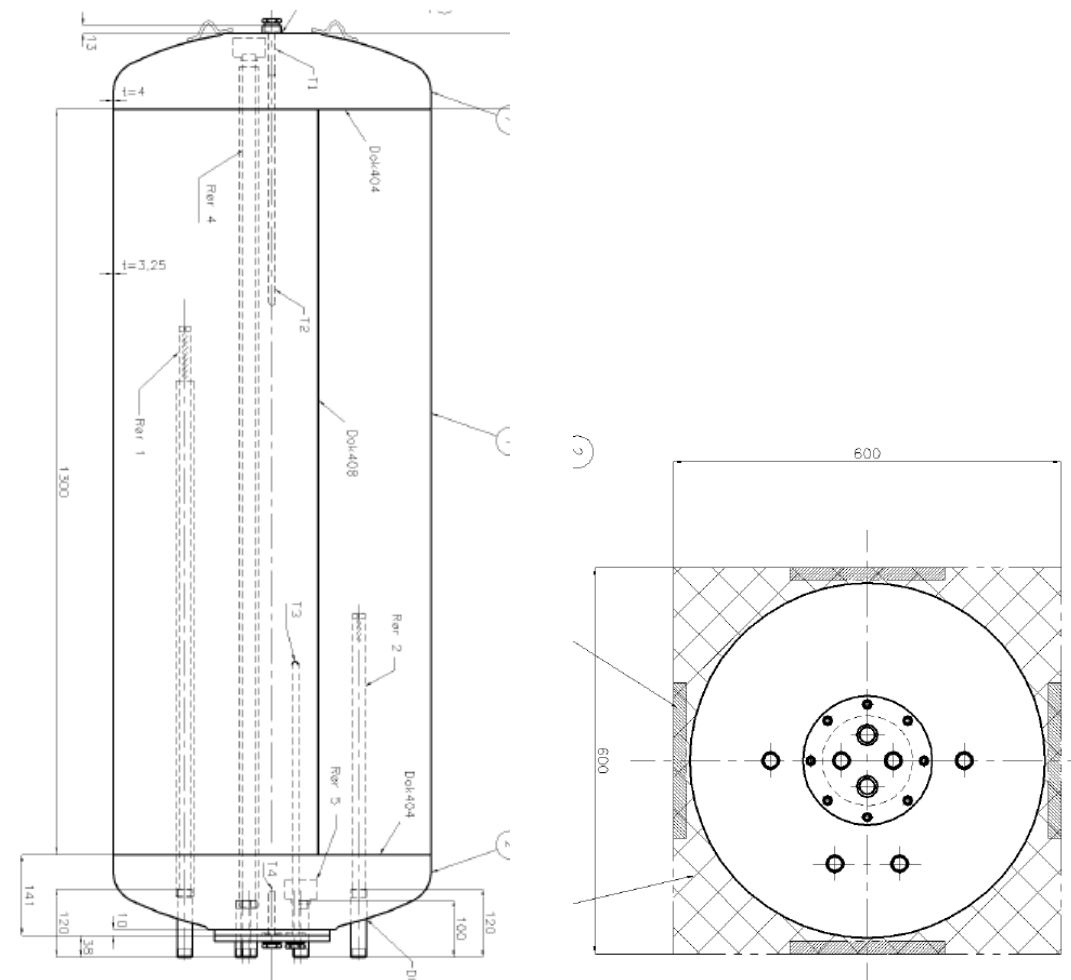

Fig. 3–4 Left: Drawing of the solar tank including the internal pipes 1-5 and the temperature sensor sockets T1-T4; Right: the tank with the vacuum panels on four sides integrated in the PUR foam.

3.2.2 Heat Loss Coefficient of Different Tank Designs

Some calculations with the finite element program THERM (Huizenga 2003) were done, in order to investigate the influence of the different tank designs relating to volume and heat loss. A large tank diameter (550 mm) with less insulation thickness (minimum = 25 mm) but using vacuum panels was compared with a smaller tank diameter (500 mm) with more insulation thickness (minimum = 50 mm). Six different cases were calculated. The following main parameters were used for the calculations:

Description of the New Concept

Tank diameter:	550 mm (case 6: 500 mm)
Cabinet dimensions:	60 x 60 cm (case 5: 65 x 65 cm)
Total insulation thickness on thinnest position:	25 mm (case 5 and 6: 50 mm)
Temperature inside:	60°C
Film coefficient inside:	1000 W/m ² K
Temperature outside:	20°C
Film coefficient outside:	8 W/m ² K
Polyurethane (PUR) Foam, heat conductivity:	0.024 W/mK
Vacuum panels, heat conductivity:	0.005 W/mK
Dimensions of the vacuum panel:	10 mm x 200 mm x 1000 mm

In Fig. 3–5, the tank with the rectangular 60 x 60 cm cabinet is shown. Due to the symmetry of the geometry, only the colored part needs to be calculated. The yellow marked part represents PUR foam, the small grey and green parts are filled with PUR foam, vacuum panel(s) or air, depending on the goal of investigation.

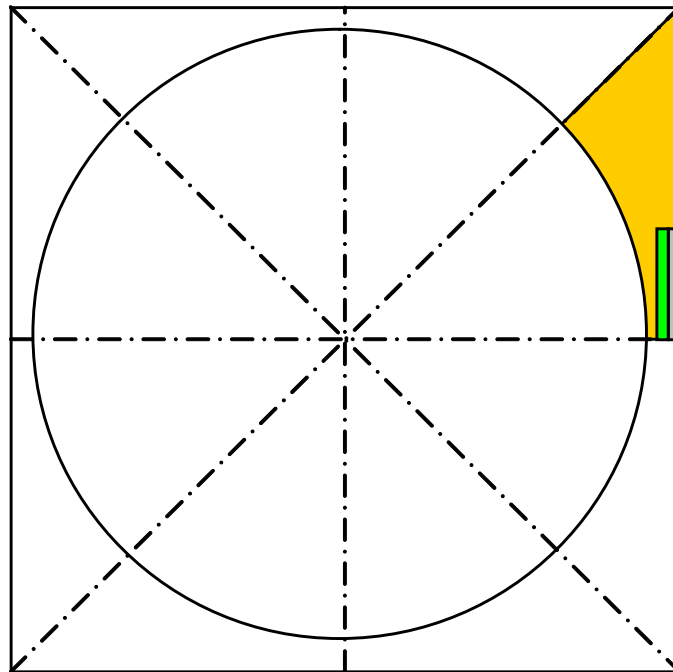

Fig. 3–5 Tank model; the colored sector was used for calculation.

The results of the six different cases which were investigated are summarized in Table 3–1. Case 6 is the base case with a tank of 500mm diameter surrounded by PUR foam within a 60 x 60 cm cabinet. The finally realized tank design is based on case 3, where 20 mm thick vacuum panels are used.

Description of the New Concept

Table 3–1 Heat loss coefficient of 1 m tank height with different insulations and PUR foam with heat conductivity of 0.024 W/mK:

No:	Tank diameter [mm]	Insulation thickness at thinnest position [mm]	Foam thickness [mm]	Air thickness*) [mm]	Vacuum panel thickness [mm]	Heat loss coeff. [W/K]	Change in [%]
1	550	25	25	0	0	0.94	165
2	550	25	15	0	10	0.65	113
3	550	25	5	0	20	0.55	96
4	550	25	5	10 *)	10	0.68	119
5	550	50	50	0	0	0.61	107
6	500 **)	50	50	0	0	0.57	100

*) In case 4 an air bubble is calculated for the whole height between a 10 mm vacuum panel and the tank. This is a very pesimistic worst case scenario for the case that an air bubble is being left somewhere during foaming.

**) Base case.

These calculations are only done for the energy losses of a 1m high cylindrical part of the tank sides. The top and bottom parts of the tank are not included in these investigations.

Comparing case 3 to base case 6 shows that using a 20 mm vacuum panel the tank with 20% more volume (due to 10% larger diameter within the same 60 x 60 cm cabinet) will result in 4% less heat losses from the tank sides compared to the small standard tank. If only the 10 mm vacuum panel is used (case 2), then the heat losses of the tank sides will be 13% higher compared to base case 6.

According to information from Metro Therm A/S the marketed standard 280 liter solar tank, which corresponds to the base case 6, has a heat loss coefficient of 1.9 W/K.

Due to problems during the foaming process, it might be possible that air bubbles will appear between the vacuum panel and the tank. Therefore, case 4 was defined as a worst case scenario using only 10 mm vacuum panel and assuming a 10 mm air bubble instead of the inner vacuum panel. Comparing case 3 with case 4 shows that in the worst case scenario this huge air bubble between the tank and the vacuum panel is increasing the heat loss coefficient from 0.55 to 0.68 W/K, which is 23%. This heat loss coefficient is still much less compared to case 1 without vacuum panel. In fact the air bubble(s) due to production failure are much smaller, so it can be assumed that the influence will be much less. Of course, this is only valid if the air bubble is closed and has no connection to outside so that no air flow can occur.

Description of the New Concept

As an example, in Fig. 3–6 the results of case 3 are presented. In the graph on the right side of the figure the isothermal lines are shown.

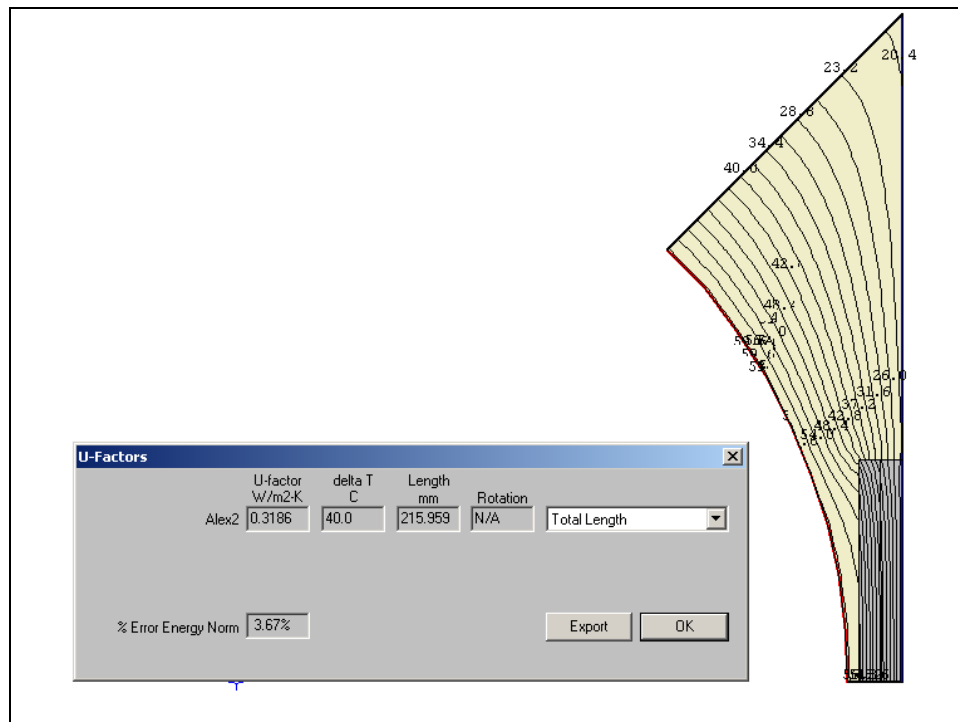

Fig. 3–6 Calculation results of case 3

3.3 Technical Unit

The technical unit is a prefabricated cabinet, again with the same dimensions of 60 x 60 cm and containing all components which are needed to run the solar combisystem. The unit which was prepared to be installed in the first demonstration system is shown in Fig. 3–7.



Fig. 3–7 Technical Unit, ready for installation in the demonstration house

Description of the New Concept

In the top of the cabinet the condensing natural gas boiler is mounted. Below the boiler in the front, the expansion vessels for the solar tank (the 3 red ones) and for the solar collector loop (the 2 white ones) are mounted. They can be easily removed without disconnecting the pipe connections to get access to all the components in the back, such as pumps, heat exchangers, mixing and switching valves, etc.

The special characteristics and advantages of this prefabricated technical unit are:

- All components are included in the two cabinets making the whole installation looking nice and therefore acceptable for installations in daily used rooms like entrance room, bath room, kitchen, etc.
- The installation time on construction site is reduced due to the prefabrication.
- The cabinet is easy to transport.
- The possibilities of mistakes during installation due to high degree of prefabrication are reduced.
- In spite of the prefabrication it is still possible for the customer to choose different suppliers for the tank and/or the boiler, which are the most costly single components.
- The technical unit can be operated also independently from the tank, which gives the possibility to invest step by step. First only the technical unit can be installed, which is supplying the house with hot water and space heating. As a second step the solar tank and the solar collector can be added.
- The minimization of the pipe length within such a compact system results in a faster reaction and in lower heat losses of the whole system.
- Due to the closed cabinet the ambient temperature for all non-insulated components is higher and therefore the heat losses are lower. The insulation of the flat cover plates of the cabinet is much easier than that of all the single pipes and components and therefore it is cheaper.
- Due to the special design of the hydraulic system and the control algorithm this system can be operated in combination with a high peak power condensing natural gas boiler in a very special way which leads to high system efficiency. This means that the natural gas boiler needs to have a peak power of about 30kW, which enables to prepare domestic hot water directly without keeping the auxiliary volume of the tank at a high temperature level. The reasons why this leads to several effects increasing the system efficiency are discussed in detail in chapter 2.

The technical unit and the controller are also prepared to operate in combination with different auxiliary heat sources than high power condensing natural gas boilers. In addition also low power condensing natural gas boiler, pellet boiler, oil boiler or district heating can be used as an auxiliary heat source. The only difference is in a parameter setting of the controller such that the auxiliary volume is kept hot at a sufficiently high temperature to ensure high enough hot water power at any time. With the advantage of using a larger auxiliary volume the hydraulic scheme in this case looks as shown in Fig. 3–8. The difference to Fig. 3–1 is just that pipe 1 is shorter and the temperature sensors Tc1 and Tc2 are positioned lower.

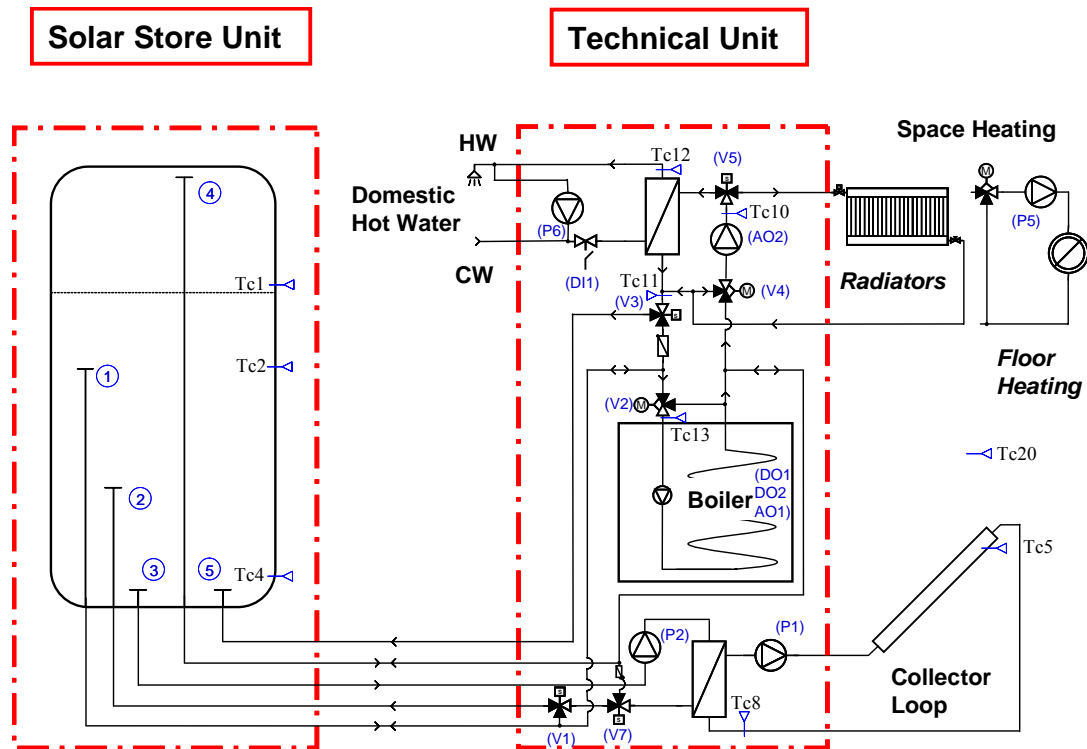

Fig. 3–8 Principle hydraulic scheme of the solar combisystem concept with enlarged auxiliary volume.

3.4 Possible Options of the Hydraulic Scheme

The controller is also prepared to operate in combination with more than one tank. For example it is possible to integrate an auxiliary tank of about 80 liter in the technical unit instead of the gas boiler (see Fig. 3–9, left) as it was done by the Swedish project partner SERC (Fiedler 2006) for their demonstration system in combination with a pellet stove. For a more advanced and compact technical unit in combination with a pellet boiler a compact 80 liter tank with a cubic shape was used at SERC as a prototype shown in Fig. 3–9 on the right.

Description of the New Concept



Fig. 3–9 Left: Top of the technical unit with a standard 80 liter auxiliary tank instead of a gas boiler. Right: Prototype of a technical unit at SERC with a cubic 80 liter tank in the top and an adapted pellet stove below.

The hydraulic concept in this case has to be changed only very little as shown in Fig. 3–10. In practice, hydraulically, the auxiliary tank is just added at the top of the solar tank. In order to be able to heat the auxiliary tank also by solar energy, it is possible to add the switching valve (V7). Otherwise in a more simple and cheaper way also the switching valve (V1) could be used when the two outlets are interchanged in their functionality (the pipe 2 outlet has to be changed to the auxiliary tank and is now the high temperature outlet).

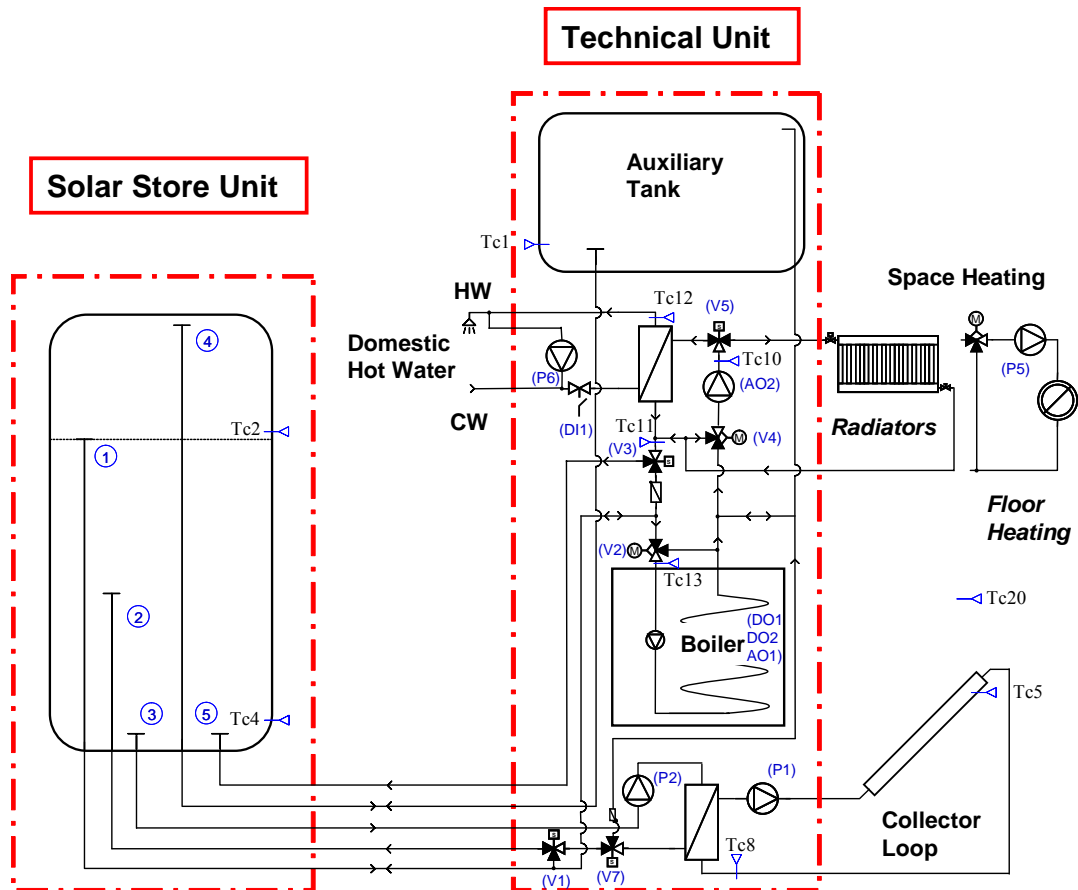

Fig. 3–10 Principle hydraulic scheme of the solar combisystem concept with auxiliary tank.

Of course the auxiliary tank can also be realized in full size as a second solar tank in order to increase the heat storage capacity more significantly as shown in Fig. 3–11. This scheme is designed to be used again in combination with a fast reacting natural gas boiler. To be able to use the two tank scheme in combination with a pellet boiler, only a parameter in the controller must be switched and the length of pipe 1 reduced, and the temperature sensors Tc1 and Tc2 must be positioned lower like shown in Fig. 3–12.

Description of the New Concept

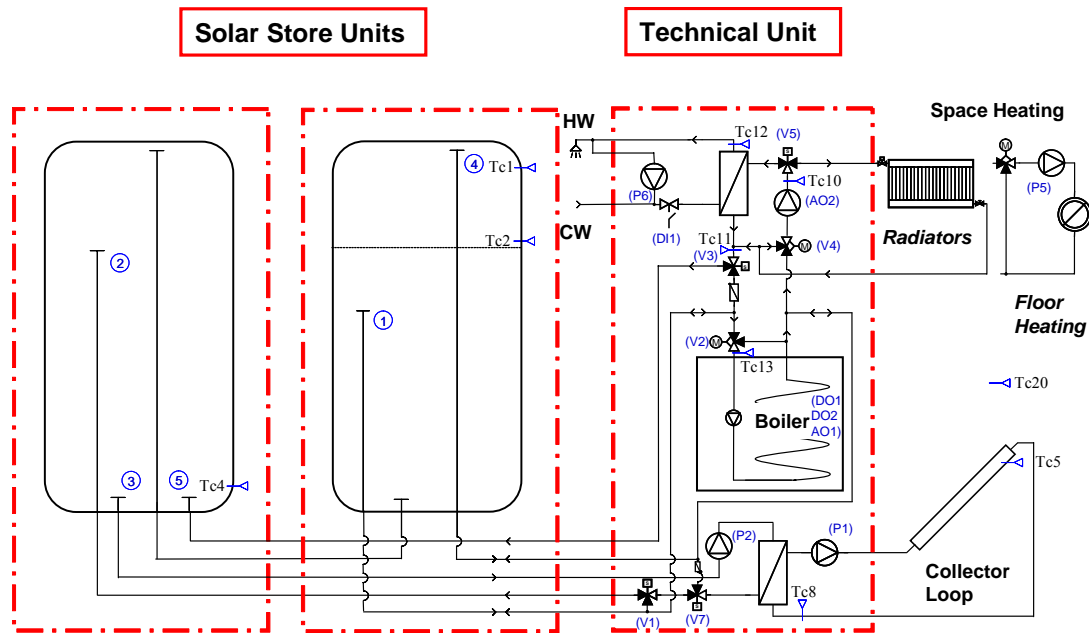

Fig. 3–11 Principle hydraulic scheme of the solar combisystem concept with two tanks to be used with a fast natural gas boiler.

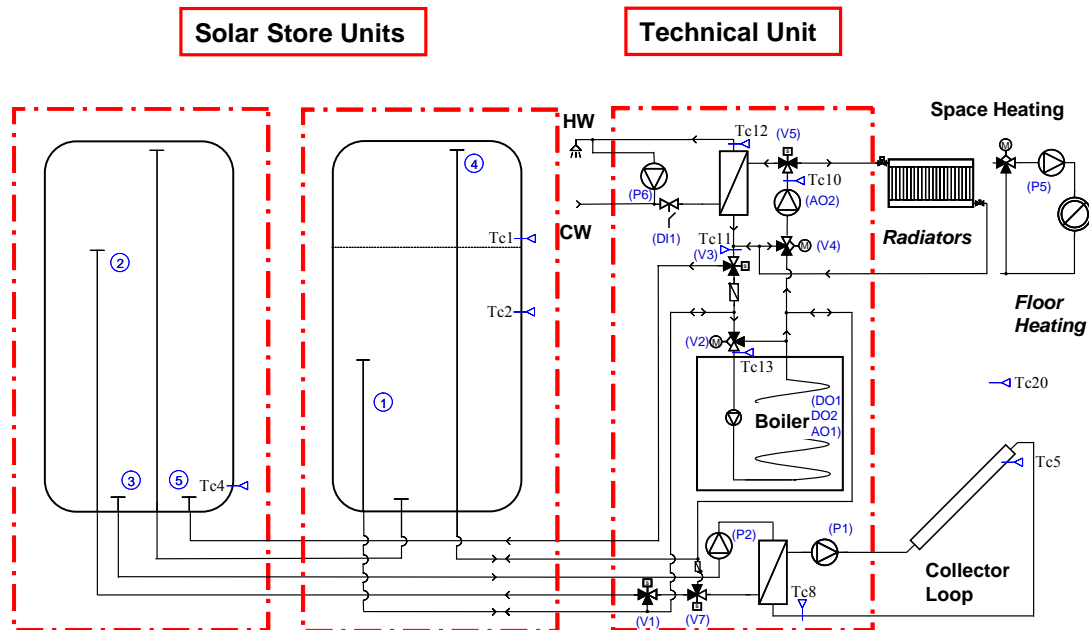

Fig. 3–12 Principle hydraulic scheme of the solar combisystem concept with two tanks to be used with a pellet boiler.

4. Annual Calculations

Based on the theoretical investigations and thoughts (see chapter 2, page 11) the concept of the new solar combisystem was designed as described in chapter 3 (page 33). In order to investigate the advantage of this system concept, further on annual calculations were done using the simulation program TRNSYS (TRNSYS 16 2004).

The major topics of the investigations based on TRNSYS calculations are the following:

1. The most important topic is to find out the difference between a conventional and the new control concept. The conventional concept always keeps the auxiliary volume of the tank at the set point temperature, which is necessary for hot water preparation. The new control concept operates the boiler only at the actual needed set point temperature depending on the actual operation mode: space heating or domestic hot water preparation. Therefore, the auxiliary volume in the tank and all the pipes and components within the system are operated in average at lower temperature leading to lower heat losses.
2. How shall the pipe connections at the tank be realized best? To achieve highest possible tank insulation quality it is clear that all pipe connections should be at the bottom in order to have totally closed tank insulation without any thermal bridges. One possibility is to pass the pipes inside the insulation to the correct height and connect the pipe from outside of the tank. An alternative is to connect the pipes at the bottom of the tank and to use internal plastic pipes, which reach to the correct height. The difference of these two possibilities on the overall system performance was investigated by means of annual calculations.

4.1 System Modelling

For this simulation model only standard types from TRNSYS are used beside one: as tank model the type 340 (former type 140) from (Drück et.al. 1996) is used. The main general parameter information about the model is given in Table 4–1, some more specific explanations about some special model characteristics will be discussed in separate chapters further on. The simulation time step in general is 6 minutes.

For the space heating load and the domestic hot water load the load files from IEA-SHC Task 26 for the Stockholm case are used (Weiss Ed. 2003):

- The space heating load file for the Stockholm climate is “LO60stock.Prn” and leads to a space heating load of 12,227 kWh per year (Streicher et.al. 2003). The design heat load for this case is 6.16 kW at -17°C ambient temperature. The design forward temperature is 40°C and the design return temperature is 35°C.
- The domestic hot water load file is “06Dhw001.txt” and leads to a domestic hot water load of about 2,000 kWh per year based on an average temperature difference of 45 K and an average daily hot water consumption of 100 liter per day (Jordan et.al. 2002).
- The weather data file is the standard TRNSYS file: “SE-Stockholm-Arlanda-24600.tm2”.

Annual Calculations

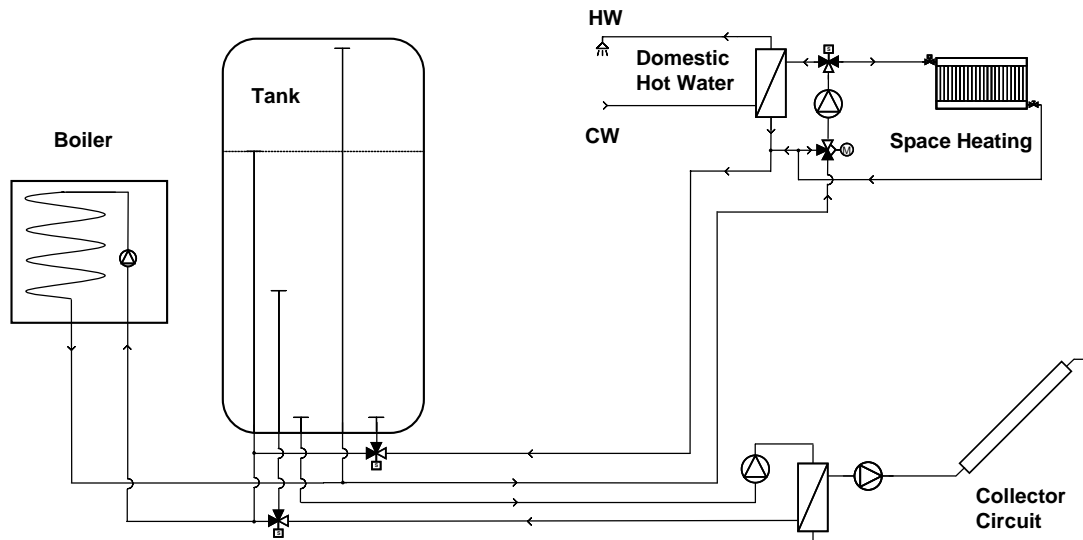

Fig. 4-1 Simplified hydraulic scheme of the simulation model of the solar combisystem.

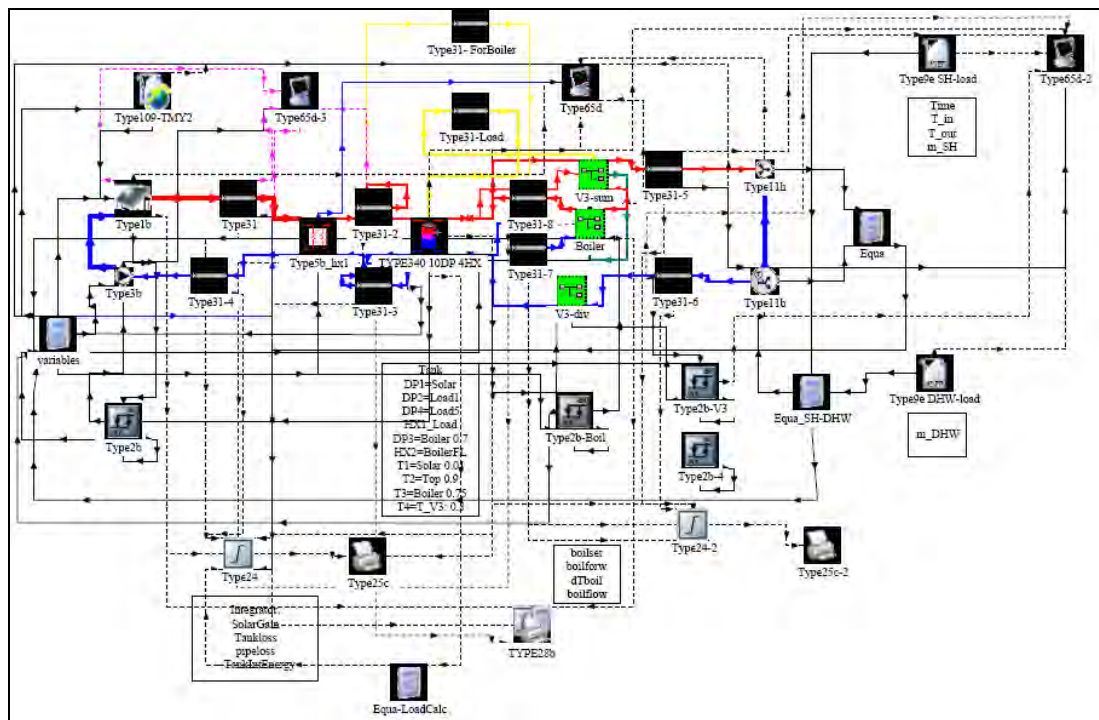

Fig. 4-2 Layout of the TRNSYS model how it looks like in TRNSYS Studio.

The hydraulic concept of the simulation model is as close as possible as described in chapter 3 (page 33). Fig. 4-1 again shows the hydraulic concept in a TRNSYS adapted way. In Fig. 4-2 the layout of the simulation model is shown as a screen-shot of TRNSYS Studio, which is the user interface program of TRNSYS.

In contradiction to most published simulation models in this model also the hydraulic circuits between solar flat plate heat exchanger and solar tank and between boiler and tank are modeled with pipes leading to heat losses. Further on the pipes from the tank to the pump and the mixing valve are modeled as well as the return pipe to the tank.

Annual Calculations

Table 4–1 General informations and parameter settings of the simulation model.

Solar collector:	
Collector area:	6 / 10 / 20 m ²
Start efficiency:	80 %
Linear heat loss coefficient:	3.611 W/m ² K
Quadratic heat loss coefficient:	0.014 W/m ² K ²
Incident angle modifier:	$k_{\Theta} = 1 - \tan^a(\Theta/2)$; a = 3.3; for $\Theta = 50^\circ$: $k_{\Theta} = 0.92$
Collector slope:	50°
Collector azimuth:	South
Solar circuit:	
Total pipe length primary circuit:	20 m
Total pipe length secondary circuit:	11 m
Inner pipe diameter:	20 mm
Pipe insulation thickness:	20 mm
Pipe heat loss coefficient:	3.823 W/m ² K; based on inner pipe diameter
Solar collector fluid specific heat:	3.68 kJ/kgK
Solar collector fluid density:	1020 kg/m ³
Solar collector flow rate:	15 kg/m ² h (0.25 kg/ m ² min)
Solar tank:	
Total volume:	300 / 500 / 1000 Liter
Overall heat loss coefficient:	2.70 / 2.73 / 3.79 W/K
Auxiliary volume:	30 % of the total volume
Height:	1.6 m
Lower solar inlet height:	0.56 m (35 %)
Upper solar inlet height:	1.12 m (70 %) (or stratifier until the top)
Boiler:	
Maximum power:	infinite
Efficiency:	100 %
Total boiler circuit pipe length:	13 m
Inner pipe diameter:	20 mm
Pipe insulation thickness:	20 mm
Pipe heat loss coefficient:	3.823 W/m ² K; based on inner pipe diameter
Load circuit:	
Total load circuit pipe length:	13 m
Inner pipe diameter:	20 mm
Pipe insulation thickness:	20 mm
Pipe heat loss coefficient:	3.823 W/m ² K; based on inner pipe diameter

4.1.1 Internal Pipes in the Tank

All the pipes inside the tank are influencing the thermal stratification in the tank due to heat exchange. If the boiler is charging the tank the forward pipe is hot and therefore also heating the lower part of the tank like an immersed heat exchanger. Other way round, if hot water is taken from the top of the tank, e.g. for hot water preparation, some heat is lost on the way to the bottom of the tank. In order to take this effect into account, the pipe connections are modeled in the following way.

In the tank type 340 all pipe connections at the tank are done via so-called double-ports, if the goal is to exchange water. To transfer heat from or into the tank is also possible via an immersed heat exchanger. To model such an internal pipe therefore it is possible to use both elements in series. For example the boiler forward pipe (hot water into the tank) first is connected to an immersed heat exchanger with flow direction from bottom to top and then to the double-port which is placed at the correct height. The tank type 340 in principle gives the possibility to model four immersed heat exchangers, but only two are allowed to overlap. Therefore the following assumptions are done:

- **Boiler circuit:** If the boiler is in operation, always both the forward and the return pipe are in use. Therefore the effect of internal heat exchange is modeled only for the boiler forward pipe, which is also the long pipe. The heat transfer coefficient for this immersed heat exchanger is set to 8 W/K (Thür et.al. 2005). This value was found by a fit of two different simulation models: As a first step both the boiler return and the boiler forward pipe inside the tank were modelled in combination with an immersed heat exchanger. In the second step the heat transfer coefficient for the boiler return pipe was set to zero and the heat transfer coefficient for the boiler forward pipe was increased until the annual auxiliary demand was equal to the result of the first step.
- **Load circuit:** Since the load return flow anyway is relative cold and most of the time in the same magnitude as the temperature in the lower part of the tank, for this pipe no immersed heat exchanger is modeled. Only the load forward pipe coming from the very top of the tank and passing the whole tank to the bottom is modeled with an immersed heat exchanger. The heat transfer coefficient for this immersed heat exchanger is set to 4 W/K (Thür et.al. 2005).
- **Solar circuit:** In type 340 no immersed heat exchanger is available anymore which is allowed to overlap, since two are used now. Anyway, since the solar forward flow is controlled via a two-way valve the long pipe only is in use if the lower part of the tank is preheated. Therefore when the flow of the solar circuit is switched to the long pipe the temperature difference between the incoming flow and the bottom part of the tank is not that large any more and the effect is also not that strong anymore.

4.1.2 Piping within the Solar Combisystem

In Table 4–1 for all four hydraulic circuits (boiler-, load-, solar primary- and solar secondary circuit) the parameters for the pipes are given. The reason for this modeling is to find out how big is the influence of the heat losses of this piping which is counted as part of the heat supply system and not of the space heating distribution system. Since these pipes (except the primary solar circuit) are in the same room as

the tank and the boiler, it is just consequent that the heat losses of these pipes are also taken into account.

In practice the situation is much more complicated, because a lot of further components than pipes are part of the piping, for example pumps and valves, which are typically not insulated and therefore can cause higher heat losses than the pipe itself.

As a first step, in this study the model is based on a simplified approach. Instead of trying to calculate an average heat loss of all components in the hydraulic circuit, the length of the insulated pipes was just enlarged. Since each system depending on the boundary conditions is looking different in that point of view, anyway these assumptions would be of low accuracy. To achieve the goal of getting some first results on this topic, it is assumed that this approach is sufficient.

4.1.3 Hot Water Preparation and Space Heating

The hot water preparation is modelled in a simplified way. It is assumed that the flat plate heat exchanger is designed in a correct way which always allows to prepare hot water at the desired tap temperature.

In practice the heat transfer coefficient of a flat plate heat exchanger of course is strong depending on the operation conditions. Also the thermal mass and the dynamic behaviour of the speed controlled pump has a quite big influence. On the other side the simulation time step is six minutes, where many hot water tapplings in practice are shorter or much shorter. Additionally, measurements in the demonstration house showed (see examples in chapter 6.3.3 on page 121) that it takes up to about one minute until the process of hot water preparation is fully stable.

Therefore it was decided to keep the TRNSYS model simple and to skip the heat exchanger and the speed controlled pump and to fix the temperatures as following:

- Hot water set point temperature: 50°C
- Primary forward temperature: 55°C
- Primary return temperature: 15°C

The reason for also fixed primary return temperature is unsatisfactory, but a result of practical work with TRNSYS: When the annual oscillation of the cold water temperature was introduced to the model, due to unexplainable reasons the program stopped the calculations with error messages. The problem unfortunately could not be solved in time.

The hot water circulation in this solar combisystem concept plays a major role in practice. But since the hot water distribution system is not modeled also no hot water circulation is taken into account.

Space heating is covered with the flow rate and the forward and return temperature always according to the load file. Due to the double use of the mixing valve and the space heating pump one effect has to be noted: During periods of hot water preparation the space heating load is not covered since the 3-way valve also in the model is switching to the hot water heat exchanger and therefore stopping the space heating flow rate. This leads finally to a reduced load in comparison with the theoretical load according to the load file.

The return flow coming from the hot water heat exchanger or the space heating circuit is stratified into the tank via a 3-way valve with two possible heights in the tank.

Depending on the return temperature and the tank temperature (at 30 % height) the return flow is stratified into the tank via the low or the high inlet pipe.

4.1.4 Boiler Integration

The boiler in all cases has 100 % efficiency and is able to modulate from 0 to 100 %. The boiler is controlled slightly different, depending if used in the solar combisystem or in the reference system:

1. Solar combisystem:

The maximum power of the boiler is set to 100 kW, just to be sure that the heat load always can be covered, since it is not goal of the investigations to find out some limitations due to the boiler power.

The boiler set point forward temperature is always according to the actual demand set point temperature plus 1 K: During hot water preparation the boiler set point forward temperature therefore is $55 + 1 = 56^{\circ}\text{C}$ with the goal to prepare hot water at 50°C at the secondary side of the hot water flat plate heat exchanger. During space heating the boiler set point forward temperature is 1 K higher than the space heating forward temperature according to the heat load file.

The hysteresis for the boiler to switch on and off is -1 K relative to the demand set point temperature (this is not the boiler set point forward temperature, which is 1 K higher!). Therefore, the boiler is switched on, if the reference temperature is just less than the demand set point temperature and switched off, if the reference temperature is 1 K lower than the demand set point temperature. During hot water preparation this means that the boiler is switched on if the reference temperature is less than 55°C and switched off again if the reference temperature is higher than 54°C , whereas the boiler forward temperature is 56°C .

With these hysteresis control settings, it is necessary that in the tank the reference temperature sensor for switching on and off the boiler is changing depending on the status of the boiler. In the case the boiler is switched off, the temperature sensor at the top of the tank (at 99 % height) is used as reference. In the case the boiler is in operation, the temperature sensor at the lower end of the auxiliary volume (at 72 % height) is used as reference.

The boiler flow rate is always according to the demand depending on the load but it is limited with minimum flow rates. During space heating the flow rate is at least 400 ltr/h and during hot water preparation the flow rate is at least 800 ltr/h. The surplus of flow rate which is not immediately used to cover the heat demand is charging the auxiliary volume. When the auxiliary volume at the lower end has reached the switch off temperature, the boiler is switched off and the heat demand is covered from the tank.

2. Reference system:

The maximum power of the boiler is set to 24 kW, the boiler flow rate is constant at 450 ltr/h and the tank set point temperature is constant at 65°C .

In this case the classical method with one fixed reference temperature sensor at the lower end of the auxiliary volume (at 72 %) is used to switch on/off the boiler. The hysteresis is chosen in a way that the boiler is started, if the reference sensor measures less than 55°C and stopped if the reference sensor measures more than 63°C .

In a first step again the boiler forward temperature was chosen to be 1 K higher than the set point temperature: $65 + 1 = 66^{\circ}\text{C}$. In practice this lead to a surprisingly high

annual auxiliary energy demand. Detailed analysis showed that with this setting the boiler circuit heat losses were very high because the boiler was switched on and off with a very high frequency. The effect was that the pipes of the boiler circuit were filled with hot water, after stopping the boiler the heat was lost and quite soon the boiler was started again and the pipes were filled again as well.

Therefore, the boiler forward temperature was increased. Finally the boiler forward temperature was set to: $65 + 12 = 77^{\circ}\text{C}$. This led in total to about 400 kWh less boiler circuit heat losses (mainly in the summer period) and therefore also to a more realistic annual auxiliary energy demand of the reference system.

4.2 Different Boiler Control Strategies

As discussed before, the major advantage of this new developed solar combisystem concept shall be that high temperature in the auxiliary volume of the solar tank and in the pipes within the solar combisystem are avoided as much as possible. The goal of this investigation is to show the potential of this new concept. How much more auxiliary energy can be saved in comparison to conventional approaches?

4.2.1 Boundary Conditions for the Calculations

Two different sized solar combisystems (as described in chapter 4.1) were simulated with two different operation strategies:

- A small sized solar combisystem with 6 m^2 collector area and a 300 liter solar tank with 90 liter auxiliary volume.
- A medium sized solar combisystem with 20 m^2 collector area and a 1,000 liter solar tank with 300 liter auxiliary volume.
- “ $T_{\text{set}} = 65^{\circ}\text{C}$ ”: As the conventional strategy, the auxiliary volume all the time was heated up to 65°C by the boiler. Therefore the set temperature of the boiler was also always set to 65°C . The mixing valve then was mixing the forward temperature to the needed temperature according to the demand, which is domestic hot water preparation or space heating depending on the ambient temperature.
- “ $T_{\text{set}} = \text{flex}$ ”: As the advanced strategy, the auxiliary volume was only used for hydraulic reasons to keep the set flow rate of the boiler all the time. However, the set temperature of the boiler was always in a flexible way set to the lowest possible forward temperature needed by space heating or domestic hot water preparation. If there was no demand, then the boiler was switched off immediately.

As a reference system the small solar combisystem was simulated with the conventional operation strategy (as described before with increased boiler forward temperature), but the solar collector pumps were always switched off. Therefore, the 90 liter auxiliary volume was always heated up to 65°C and the system is essentially a boiler with domestic hot water store. The energy savings are defined as the difference between the heat delivery of the boiler in the reference system minus the heat delivery of the boiler in the solar combisystem. The solar fraction is defined as the ratio of the energy savings to the total energy demand.

4.2.2 Annual Calculation Results

In Table 4–2 the results of the calculations are presented in detail and in Fig. 4–3 as a summary for the case of the small solar combisystem.

First some explanations to Table 4–2:

- Solar tank volume: Total volume / Auxiliary volume (= 300/90 or 1000/300)
- Total losses are the tank losses plus all pipe losses, including the primary and secondary solar circuit heat losses.
- To get a closed energy balance, the energy gap (which always was less than 0.3 % of the total energy input) due to the uncertainty of the calculations was added to the tank heat losses.
- All specific energies [kWh/m²] refer to the collector area: 6 or 20m²

The four columns left of the “Reference” in Table 4–2 will be discussed first. Looking on “Collector gain” and “Solar energy into tank” for both system sizes the improvement due to the improved, flexible operation strategy is between 7 and 13 %. In both cases the collector gain increased slightly less (plus 7 % and 8 %) compared to the solar energy delivered into the tank (plus 9 % and 13 %).

But the most interesting fact is: How much “Energy delivered by boiler” can be reduced? This is shown by the “Energy savings” and the “Solar Fraction” respectively. In case of the small solar combisystem due to the advanced operation strategy the energy savings could be increased by 83 % compared to the conventional operation strategy. This is 10 times more than the improvement of the “Collector gain” which was 8 %. For the large solar combisystem the advantage is not that large, but still the energy savings could be increased by 33 %, which is also significantly more than just 7 % higher “Collector gain”.

The explanation for this big difference in improvement of “Collector gain” and improvement of the energy savings is found by analysis of the heat losses in the system. Comparing the “Tank losses” shows a potential of reduction of 14 and 25 % respectively. The “Load pipe losses” can be reduced by 36 % and 44 % respectively, this is almost the double effect compared to the tank losses.

But the major effect can be seen by the reduction of the “Boiler pipe losses”: about 80 % less heat losses for both system sizes due to the advanced control concept. Finally the total heat losses in the small sized solar combisystem can be reduced by 43 % or 1,252 kWh and by 29 % or 965 kWh in the medium sized solar combisystem. In other words: for both sizes this corresponds to the energy savings of more than 4 m² collector area of the conventional controlled solar combisystem.

In Fig. 4–3 the results are shown for the small sized solar combisystem as a graph. On the right half of the graph the top part of three columns show impressive the huge influence of the pipe losses (boiler and load circuit).

Annual Calculations

Table 4–2 Summary of the calculation results of different boiler control strategies for two different sized solar combisystems (SCS).

		SCS small	SCS small	SCS large	SCS large	Reference	SCS small
Control strategy		T_set = 65 °C	T_set = flex	T_set = 65 °C	T_set = flex	T_set = 65 °C	T_set = 65 °C
Solar circuit losses	Yes / No	Yes	Yes	Yes	Yes	-	No
Collector area	m ²	6	6	20	20	0	6
Solar tank volume	ltr	300/90	300/90	1000/300	1000/300	300/90	300/90
Energy delivered by boiler	kWh	13964	12469	11560	10195	15756	13704
Total energy demand (DHW+SH)	kWh	13632	13605	13632	13620	13639	13632
Tank losses	kWh	886	662	1402	1209	636	910
Difference	kWh		-224		-193		24
Difference	%		-25%		-14%		3%
Boiler pipe losses	kWh	947	185	685	131	933	893
Difference	kWh		-762		-554		-54
Difference	%		-80%		-81%		-6%
Load pipe losses	kWh	499	279	521	332	548	501
Difference	kWh		-220		-189		2
Difference	%		-44%		-36%		0%
Solar pipe losses	kWh	582	536	678	649	0	0
Difference	kWh		-46		-29		-582
Difference	%		-8%		-4%		-100%
Total losses	kWh	2914	1662	3286	2321	2117	2304
Difference	kWh		-1252		-965		-610
Difference	%		-43%		-29%		-21%
Collector gain	kWh/m ²	430	466	268	287	0	372
Difference	kWh/m ²		36		19		-58
Difference	%		8%		7%		-14%
Solar energy into tank	kWh/m ²	333	377	234	255	0	372
Difference	kWh/m ²		44		21		39
Difference	%		13%		9%		12%
Solar fraction	%	13%	24%	31%	41%	0%	15%
Difference	%		84%		33%		15%
Energy savings	kWh/m ²	299	548	210	278		342
Difference	kWh/m ²		249		68		43
Difference	%		83%		33%		15%

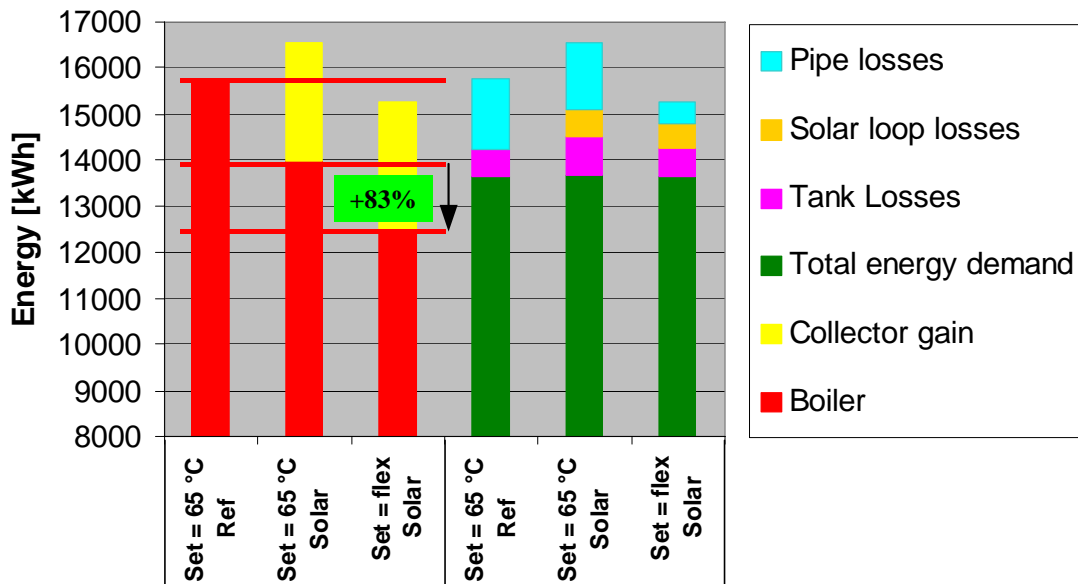

Fig. 4–3 Increase of the energy savings by 83 % due to the advanced control concept for the small sized solar combisystem: 6 m² collector area and 300 liter tank.

A final look on Table 4–2 shows how complex a solar combisystem is acting. The most right column shows the calculation result of the small sized solar combisystem, which is conventionally controlled but assuming that the solar circuit pipes have perfect insulation and therefore no heat losses. This result has to be compared with the first column where due to the heat losses in the collector circuit the “Solar energy into tank” is 97 kWh/m² less than the “Collector gain”. But assuming no heat losses in the collector circuit is resulting in an increase of “Energy savings” of only 43 kWh/m². The main reason for this effect is that during summer period the collector circuit heat losses mostly can be compensated by longer operation periods. This is possible in solar combisystems since in the summer period such a system typically is clear oversized.

4.2.3 Conclusions

The calculations showed that there is a large difference in energy savings between the two control strategies, especially for small sized solar combisystems. The investigated energy savings could be improved by 83 % for the small and 33 % for the medium sized system compared to traditional controlled solar combisystems based on the described assumptions.

These energy savings are only due to reduced heat delivery of the boiler since in this study no boiler efficiency was taken into account. For condensing natural gas boilers it is expected that due to better operating conditions for the boiler within this system concept the fuel consumption will be reduced disproportionate to the energy savings as an additional benefit. Long term measurements in a one-family house shall demonstrate this effect (see chapter 6.4.5 on page 134).

The conventional control concept investigated in this simulation study on the one hand side for sure is somehow a worst case scenario for a solar combisystem in combination with condensing natural gas boilers (e.g. for pellet boiler this is the standard case). There are of course hydraulic concepts on the market, which more or less are able to operate also at lower temperature levels, and achieve high coefficients of performance (see Austrian example in chapter 6.4.5, page 134 and Fig. 6–34, page 136). On the other side, the best performing solar combisystem evaluated within the IEA-SHC Task 26 project (Weiss Ed. 2003) was the “Generic system #15” (Jähnig 2002) which is controlled exactly like the conventional case in this investigation. Due to a tank integrated condensing natural gas burner the “boiler” losses are almost eliminated. Since this system also has no boiler pipes, the boiler circuit heat losses are totally eliminated. These are the major reasons for the high performance of this system.

Therefore, the result of this investigation has to be interpreted as a comparison between a relatively bad, but still realistic conventional case and the proposed new, advanced case.

Further, the absolute number of 83 % higher energy saving is not the main message of this investigation. Much more important is the fact that the main potential in improving the energy savings is based on a reduction of the heat losses of all the pipes and other components within the solar combisystem. This can be done by reducing the temperatures (as shown in these investigations) but also by reducing pipe length and by increasing the compactness of the complete solar combisystem.

4.3 Influence of Pipe Connections at the Tank on the Energy Savings

How to connect the pipes from solar collector loop, boiler loop and heating loop to the tank is a basic tank design problem. Based on the typical production technique of the industry partner METRO THERM A/S two designs were investigated. To reach the goal of having a best insulated tank with minimized thermal bridges it was clear that all pipes should be led into the tank from the bottom part. Based on this design principle it is not necessary to break through the tank insulation for pipe connections. The first solution is to connect the pipes at the bottom and to go to the right level inside the tank by PEX pipes with the right lengths (Fig. 4–8 left).

The second possibility is to pass the pipes from the bottom inside the tank insulation to the right height and to connect the pipe on the side wall of the tank (Fig. 4–8 right). Now it is known that different effects will influence the yearly thermal performance of the whole system. The first solution has shorter pipe lengths in the room compared to the second solution which leads to lower pipe losses. Further, a pipe connection located at the side of a tank, even when inside the tank insulation, results in somewhat higher energy losses due to the thermal bridge effect than a pipe connection located at the bottom of a tank. But the PEX pipes inside the tank also act as a kind of internal heat exchanger which leads to destratification of the tank which again has disadvantages on the performance of the collector and the auxiliary demand as well. But which effects will dominate?

Based on TRNSYS simulations with several parameter variations the influence of these two designs on the thermal performance of the whole system was investigated.

4.3.1 Validation of the TRNSYS Model Based on Laboratory Experiments

In the year 1994 at DTH (today: DTU) some experiments were done to investigate the influence on the thermal performance of different pipe connections for hot water circulation pipes at hot water tanks (Furbo 1994). It was compared first to connect the forward pipe at the top of the tank and second (Fig. 4–4) to use a 2016 PEX pipe (outer diameter = 20 mm, inner diameter = 16 mm) inside the tank from the top to the bottom and to connect the forward pipe of the circulation loop at the bottom of the tank. To get the right parameters for simulations some tests were done over a time period of 24 hours. The first 9 hours an electric heater with 1000 W power heated up the auxiliary part of the tank (total volume: 275 ltr, auxiliary volume: 115 ltr, volume above the circulation return pipe: 75 ltr). For the reference test (Fig. 4–4) until the end of the 24 hours the circulation pump was not switched on and the electric heater just had to keep the set temperature of about 50.5°C. For the circulation test (Fig. 4–6) after 9 hours the circulation pump was switched on and the mass flow controlled in a way, that the return temperature into the tank was always about 45°C resulting in about 100 W pipe losses.

Annual Calculations

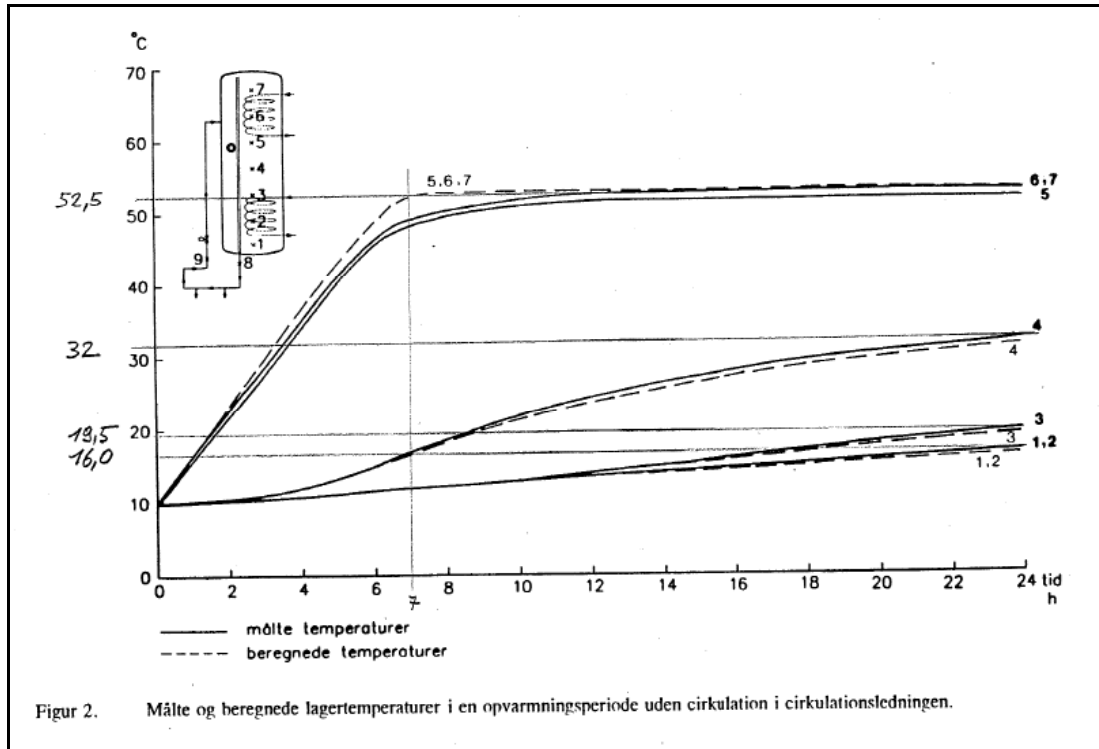

Fig. 4-4 Reference test: measured.

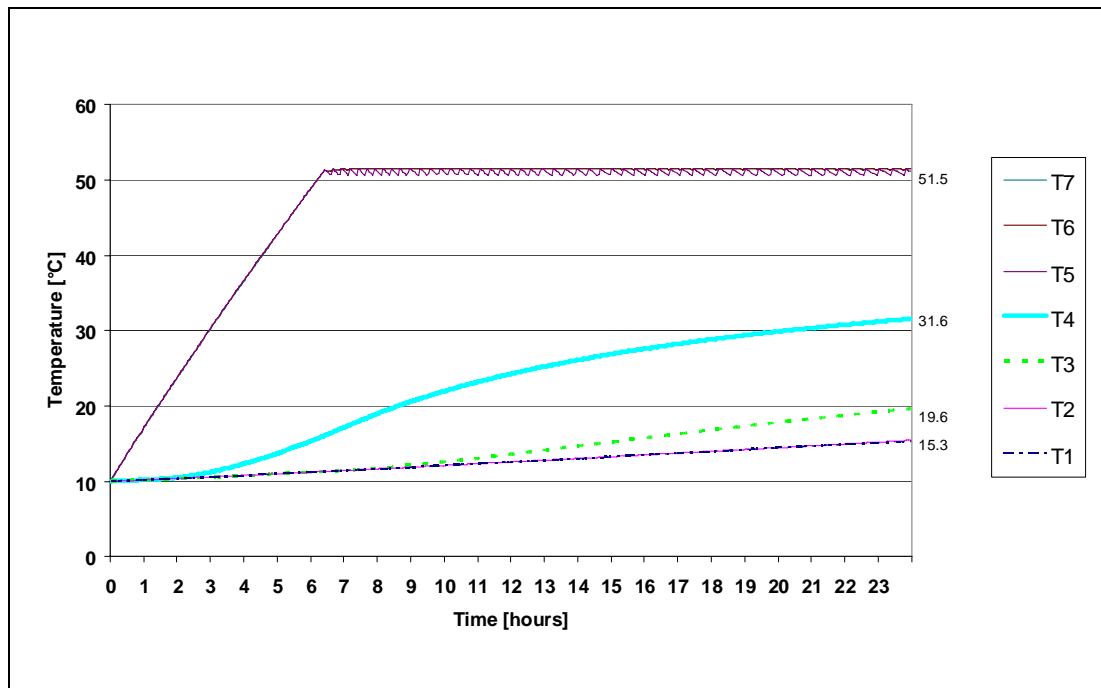

Fig. 4-5 Reference test: calculated.

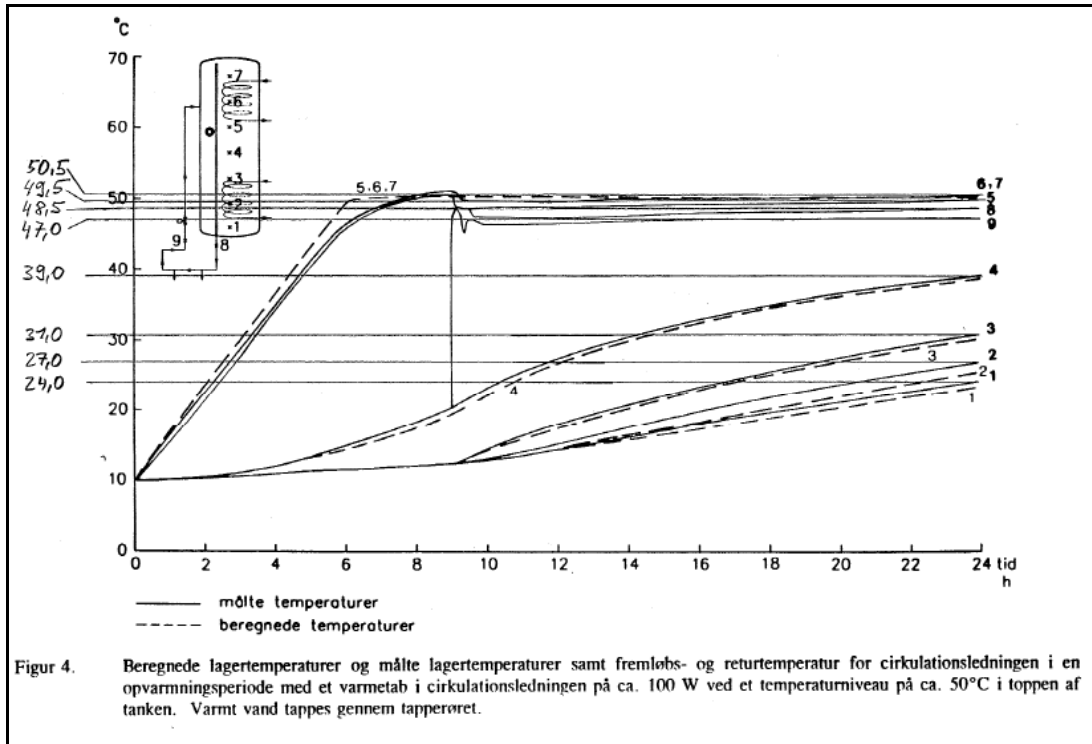

Fig. 4–6 Circulation test: measured.

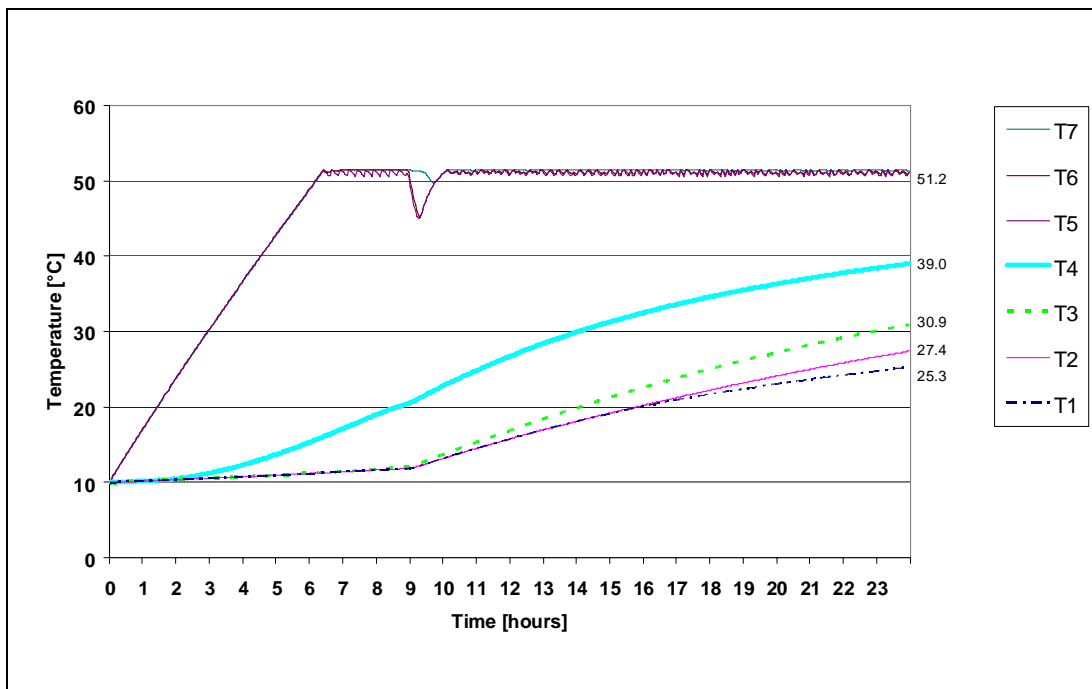

Fig. 4–7 Circulation test: calculated.

For both tests seven temperatures inside the tank were measured and plotted. Now with TRNSYS the experimental setup of these tests was modeled (Fig. 4–5 and Fig. 4–7) and with this tool it is possible to model the PEX pipe like an internal heat exchanger. The goal was to find the correct UA-value for the PEX pipe. Based on theoretical calculations using the theory of heat transfer for free convection (based on the dimensionless numbers of Nusselt, Grashof and Prandtl) for the 2016 PEX pipe

with a length of 1.45 m, 50°C inside the pipe and depending on the tank temperature UA values between 10.2 (tank temperature = 40°C) and 11.3 W/K (tank temperature = 20°C) were found.

With parameter fitting based on several TRNSYS simulations it was found that the UA value of 10.5 W/K for the 2016 PEX pipe fits best to get the most similar temperature curves compared to the experimental results (Fig. 4–6 and Fig. 4–7). This fitted value also is in the range of the theoretical calculated UA values.

4.3.2 Description of the Simulation Models and the Parameters

Based on these findings it can be stated that the TRNSYS model is simulating the reality with a very high degree of similarity. As the next step now the model of the solar combisystem was set up to be able to do the investigations which are in fact the goal of the whole work.

The model is in principle built up as described in chapter 4.1 (page 47), but the control concept for these investigations is different. The maximum power of the boiler is limited to 24 kW and the boiler set point temperature is 65°C all the time. Further, the auxiliary volume is always kept at 65°C as well.

As shown in Fig. 4–8 it is assumed that the system is situated in the house in a technical room, most likely in the basement. Practical experience is, that because of a lot of specific possible reasons the installers pass the pipes from the tank to the ceiling, further to the wall and then downwards to some components like a heat exchanger, the boiler or the pump and mixing unit. Based on this circumstance some metres of piping can be summed up which in most cases cause energy losses since they are heating a room which is very effectively cooled by fresh air coming in by a hole in the wall to be used in the boiler for combustion. This of course causes remarkable energy losses which not always simply can be calculated to heat the house and therefore not to be real energy losses. Due to the different designs of the pipe connections, different lengths of piping have to be calculated.

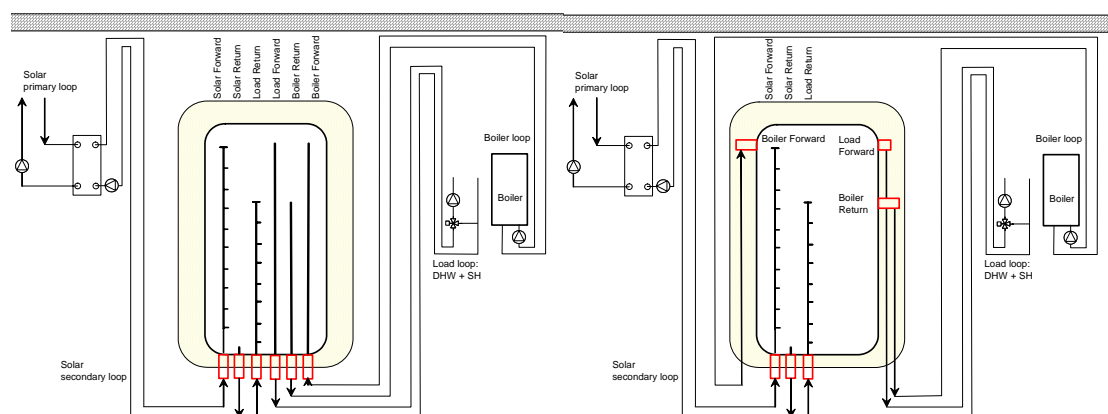

Fig. 4–8 Solar combisystem with pipe connections at the bottom (left) and pipe connections at the tank side (right).

In Fig. 4–8 on the left the design with all pipe connections at the bottom and the use of only internal pipes is shown, therefore this system concept in the following has the abbreviation “int”. These internal pipes are PEX pipes, which is a widely used plastic material for pipes inside water tanks. In Fig. 4–8 on the right the design with the pipe

connections for the load forward pipe and both boiler pipes external on the side of the tank is shown, therefore this system concept in the following has the abbreviation “ext”. In the simulation model it is assumed that all the pipes inside the insulation of the tank have the same thermal behaviour as they would have, if they were mounted outside of the insulation and being insulated like all the other pipes. But no thermal bridges are taken into account for this kind of pipe connection on the side of the tank. This can be argued since in this particular case of tank producer the insulation has a quadratic cross section but the tank itself is round. The pipes are connected in the corners of the quadratic casing where the thickness of the insulation is much larger than at the thinnest part, which is the insulation thickness in fact used in the model for the whole tank.

In general in the model of all different variations all pipes outside the tank are copper pipes 22x1 with 20 mm insulation, which results in a heat loss coefficient of 3.8 W/Km^2 . The pipe length of the solar primary loop (from collector to heat exchanger and back) is 20 m and the solar secondary loop (from heat exchanger to the tank and back) is 11 m.

The solar forward pipe and the load return pipe inside the tank are assumed to be stratification pipes. Because this configuration in all different designs does not change and also because of limitations of the tank model of the simulation program TRNSYS these two internal pipes are not modelled as an internal heat exchanger.

The length of the boiler loop is depends on the system concept, with internal pipes the length is 13 m (Fig. 4–8 left) and with external connection it is 15.5 m (Fig. 4–8 right).

The length of the load loop is also depends on the system concept, with internal pipes the length is again 13 m and with external connection it is 14.5 m.

For the concept with the internal pipes two different pipe dimensions with different heat transfer coefficients (when modelled as internal heat exchanger) were investigated. The abbreviation 2016 indicates PEX pipes with outer diameter of 20 mm and inner diameter of 16 mm. The heat transfer coefficient for this pipe was calculated to be 12 W/K. This value is somewhat higher compared to the one calculated in chapter 4.3.1 because the pipe is slightly longer (1.6 m instead of 1.45 m) and the temperature inside the pipe here is 70°C (only 50°C before). The abbreviation 3216 indicates PEX pipes with outer diameter of 32 mm and inner diameter of 16 mm. The heat transfer coefficient for this pipe was calculated to 4 W/K.

To investigate the difference of the two system concepts also for different system sizes, three different collector sizes and tanks were defined.

All three tanks had the same height of 1.6 m and also all connection heights were constant. This fact maybe might not be perfectly realistic, but it ensures to eliminate height effects on the behaviour of the internal pipes acting as internal heat exchangers. Based on this decision the three different tanks have total volumes of 300, 500 and 1,000 liter, the auxiliary volumes are 90, 150 and 300 liter respectively. The tanks are insulated with different insulation thickness, depending on their size. The 300 liter tank was calculated with 50 mm, the 500 liter tank with 80 mm and the 1,000 liter tank with 100 mm insulation respectively. Therefore, the overall heat loss coefficients of the three tanks are for the 300 liter tank 2.70 W/K , for the 500 liter tank 2.73 W/K and for the 1,000 liter tank 3.79 W/K respectively.

The collector size was kept in a constant ratio to the tank volume of 50 liter per m^2 collector area. This results in 6, 10 and 20 m^2 , respectively.

4.3.3 Simulation Results

Using the above described models a lot of annual calculations with different parameter settings were done to investigate the influence of the different concepts how to connect the pipes to the tank. The following parameters were changed:

Size of collector area and tank volume:

- 1) 6 m² and 300 liter
- 2) 10 m² and 500 liter
- 3) 20 m² and 1000 liter

For each size again the type of pipe connection was changed:

- 1) External pipe connection
- 2) Internal pipe connection

Last but not least for the internal pipe connection again two different pipe dimensions were simulated:

- 1) PEX pipe 2016 (da = 20 mm, di = 16 mm)
- 2) PEX pipe 3216 (da = 32 mm, di = 16 mm)

So all in all 3 x 3 = 9 simulations (plus some special investigations) were done.

The system with external pipe connections, without collector and with the 300 liter tank, with only the top 90 liter heated, was simulated to be used as the reference. This system is very close to a typical heating system used in Danish houses.

1. Overall comparison of the simulation results

In Fig. 4–9 the auxiliary demand (=energy produced by the boiler, this is not the fuel consumption) for the reference system and the different investigated systems is presented. The energy demand on the load side for domestic hot water (DHW) and space heating (SH) for all systems is the same: 13,637 kWh per year.

In general the reduction of auxiliary demand is strongest influenced by the size of the system, only little depending on the concept how to connect the pipes at the tank. Compared to the reference system the smallest solar combisystem (SCS) with 6 m² collector area can reduce the auxiliary demand by about 12 %, the medium sized system with 10 m² can reduce the auxiliary demand by about 18 % and the largest sized system with 20 m² can reduce the auxiliary demand by about 26 %.

In Fig. 4–10 the difference between the 3 investigated concepts is shown based on the specific energy savings. This number is calculated by subtracting the auxiliary demand of the reference system minus the auxiliary demand of the investigated system, divided by the collector area of the investigated system. In fact this number shows how much auxiliary energy per square meter collector area could be saved by the solar combisystem. The concept Int2016 in general has the lowest performance compared to the other two concepts. However, in relative numbers the difference is getting less with growing system sizes. Compared to the best performing concept Int3216 the concept Int2016 has a reduced performance of -5.8 % (6 m²), -4.2 % (10 m²) and -3.8 % (20 m²), respectively.

Auxiliary demand to cover a total heat load of 13,637 kWh per year for DHW and SH

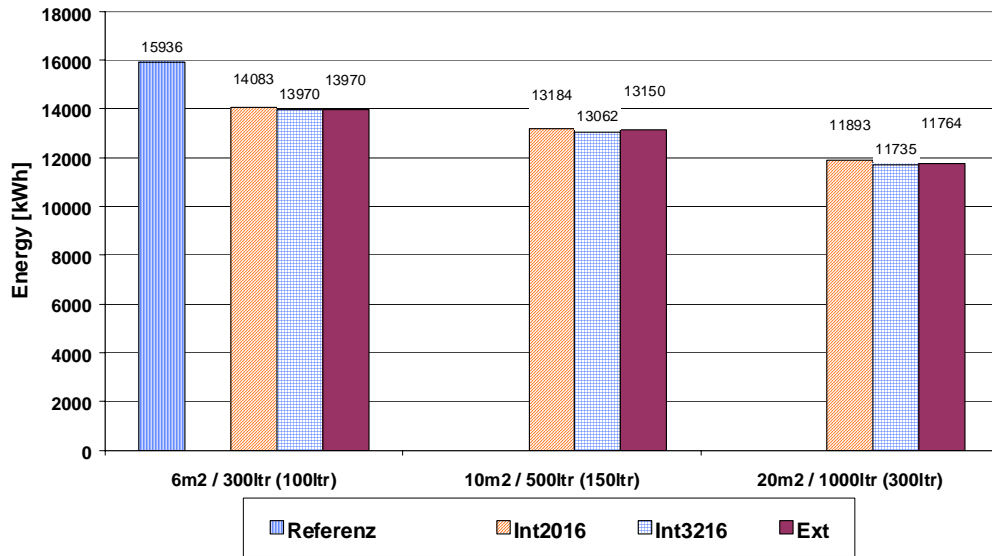

Fig. 4–9 Yearly auxiliary demand of the reference system and the three system sizes with the three system concepts, respectively.

Comparing Int3216 and Ext shows that Int3216 has the highest performance but very strongly depending on the system size. For the small and the large sized system no or almost no difference can be observed, for the medium sized system Int3216 performs 2.9 % better than Ext. This shows that obviously the difference in the performance is also influenced in the same magnitude by other parameters than by these two different concepts of how to connect the pipes to the tank.

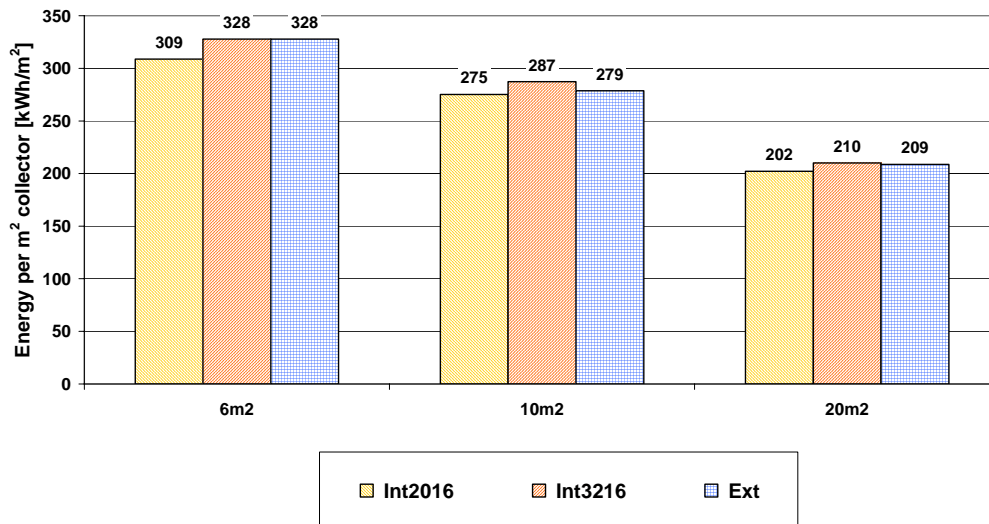

Fig. 4–10 Energy savings for the three investigated system concepts and the three system sizes respectively.

Which parameter these could be was not possible to determine. Most likely caused by different geometric parameters (height/diameter, insulation thickness/volume, surface/volume, etc.) the tank losses are changing in a way to get the observed results.

Additionally, seasonal effects or simply inaccuracy of the simulation program might influence the results as well.

2. Detailed analysis of the energy balance

After discussing the overall results now some detailed results will be presented, trying to explain different effects which can be observed. In Fig. 4–11 for the medium sized system with 10 m² collector area and the 500 liter tank the energy balance for the three investigated pipe connection concepts is presented. The energy values are shown in absolute numbers in kWh inside the columns. The columns themselves are standardized to a percentage scale to give a better impression on the ratios between the different parts of energies. The numbers are also shown in Table 4–3.

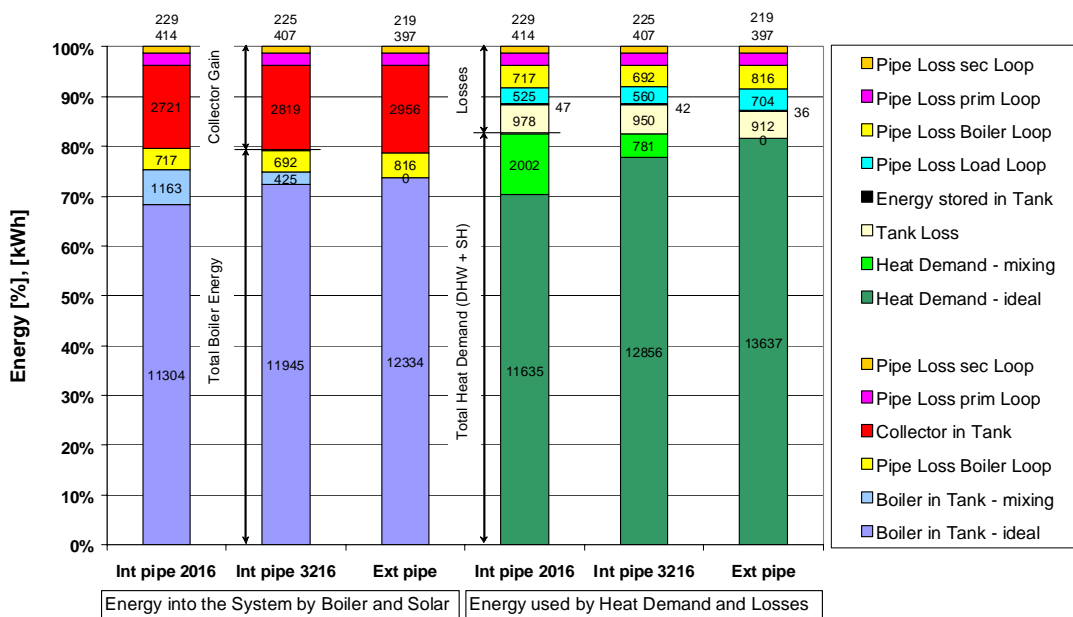

Fig. 4–11 Energy balance of the three system concepts for the 10 m² and 500 liter system size (see also Table 4–3).

The three columns on the left side show how the energy is produced from the two energy sources boiler and collector. From bottom to the top the first three parts are related to the boiler, the second three parts are related to the collector.

The first part “Boiler in tank – ideal” is the amount of energy coming from the boiler which is put into the tank at the top level where the internal pipe ends or the external pipe is connected to the tank respectively.

The second part “Boiler in tank – mixing” is the amount of energy coming from the boiler which is put into the tank when passing the internal pipe from the bottom to the top of the tank like via an internal heat exchanger. Depending on the thermal stratification in the tank in different heights more or less energy is lost from the internal pipe to the tank before the hot water reaches the top. In the case “Int pipe 2016” 1,163 kWh or about 10 % of the energy coming from the boiler into the tank is not only heating the top of the tank, but the lower parts as well. In the case “Int pipe 3216” only 425 kWh corresponding to about 4 % have a much smaller effect. Of course in the case “Ext pipe” this part is zero.

Annual Calculations

The third part “Pipe loss boiler loop” represents the pipe losses of the boiler loop. The energy for these losses of course also has to be produced by the boiler.

The fourth part “Collector in tank” is the part of energy produced by the collector which finally really comes into the tank.

Part five “Pipe loss prim loop” and six “Pipe loss sec loop” are finally the pipe losses of the primary loop (collector to heat exchanger) and the secondary loop (heat exchanger to the tank) which are necessary to transfer the energy from the collector to the tank.

Table 4–3 Energy balance of the three system concepts for the 10 m² and 500 liter system size (see also Fig. 4–11).

	Int pipe 2016	Int pipe 3216	Ext pipe
Energy production:			
Boiler in Tank - ideal	11304	11945	12334
Boiler in Tank - mixing	1163	425	0
Pipe Loss Boiler Loop	<u>717</u>	<u>692</u>	<u>816</u>
Total Boiler production	13184	13062	13150
Collector in Tank	2721	2819	2956
Pipe Loss prim Loop	414	407	397
Pipe Loss sec Loop	<u>229</u>	<u>225</u>	<u>219</u>
Collector gain	3363	3451	3571
Energy use:			
Heat Demand - ideal	11635	12856	13637
Heat Demand - mixing	<u>2002</u>	<u>781</u>	<u>0</u>
Heat Demand (SH and DHW)	13637	13637	13637
Tank Loss	978	950	912
Energy stored in Tank	47	42	36
Pipe Loss Load Loop	525	560	704
Pipe Loss Boiler Loop	717	692	816
Pipe Loss prim Loop	414	407	397
Pipe Loss sec Loop	<u>229</u>	<u>225</u>	<u>219</u>
Total Losses	2909	2876	3084

The three columns on the right side show how the energy is used. Again from bottom to top the first two parts show the total heat demand which is the goal to be covered by the heating system. The six other parts show all the different types of energy losses which of course also have to be covered by the energy sources collector and boiler.

The first part “Heat demand - ideal” and the second part “Heat demand - mixing” together are the heat demand of space heating and domestic hot water which has to be covered. The second part “Heat demand - mixing” again shall demonstrate how big is the effect of destratification of the tank because of the behaviour like an internal heat exchanger of the internal pipe where the hot water is taken out of the tank. This means that in the case “Int pipe 2016” when taking 13,637 kWh out of the tank, additional 2,002 kWh are transferred from the top of the tank to lower parts of the tank. This amount of energy represents about 15 % of the demand for the “Int pipe 2016” pipe and about 6 % in the case of the “Int pipe 3216” pipe. Of course in the case “Ext pipe” this energy part is zero.

Annual Calculations

Part number three “Tank loss”, quite simply are the tank losses.

The part “Energy stored in tank” in fact has two parts which are roughly of the same order. One part is what it says: the change of the internal energy between the beginning and the end of the simulation period of one year. The other part is the missing amount of energy caused by inaccuracies of the iterations in the simulation program. This missing part of energy typically is in the order of about 0.25 % of the total energy turnover.

The last four parts of the right columns are simply the energy losses of all the piping of the whole heating system. These are the pipe losses of the load loop (to cover the heat demand), the boiler loop and also again the primary and secondary solar collector loop.

Comparing the three left columns, which are showing the energy production gives some more interesting information.

Because of the destratification effect of the internal pipes the average temperature in the lower part of the tank is higher in the “Int” cases than in the “Ext” case. The result can be clearly seen in the collector loop and the solar gain. “Int pipe 2016” compared with “Ext pipe” shows that obviously because of a higher temperature level the collector gain is 6 % lower for “Int 2016” than for “Ext”. Additionally also the pipe losses in the solar loops are 4 % higher which in the end leads to in total 8 % less energy from the collector coming into the tank. In the case “Int pipe 3216” the disadvantage in total is 5 % less energy from the collector coming into the tank.

Also in the boiler loop differences in the same order can be observed, but the other way round. Because of an in total 2.5 m longer boiler loop (this is about 19 %) of course the pipe losses in the case “Ext” are 14 % or 18 % higher than in the “Int” cases. In absolute numbers, “Ext” with the 124 kWh higher boiler pipe losses lost the advantage of the higher collector gain (this was 120 kWh more for “Ext” compared to “Int 3216”).

Also the difference in the boiler loop losses of the two “Int” cases is interesting. Because of the better insulation of the 3216 PEX pipe compared to the 2016 PEX pipe two effects are working. From the 3216 PEX return pipe slightly higher return temperatures to the boiler lead to also slightly higher boiler return pipe losses. Since the boiler always heats to the same forward temperature, no changes of the boiler forward pipe losses take place. However, the 3216 PEX inlet pipe loses less energy in the lower parts of the tank because of better insulation. Because of this reason now the auxiliary volume more efficiently and much faster is heated to the set temperature that leads to shorter operation time of the boiler loop, and further on, obviously to lower total boiler pipe losses.

Further, the three right columns show how the energy is used. As discussed before the internal pipes have destratification effects, these can also be observed when looking at the tank losses. Because the lower part of the tank has in average higher temperature (but not usable) this also leads to 7 % and 4 % higher losses of the “Int” cases compared to the “Ext” case.

Last but not least also the pipe losses of the load loops have significant differences. The “Int” cases have 25 % and 20 % lower load pipe losses than the “Ext” case. This is first of all quite simple due to 10 % (13 m instead of 14.5 m) shorter pipe lengths. But only about 10 % lower pipe losses can be explained by the shorter pipes. The remaining 10 to 15 % must be explained by other effects. Now the heat exchanger effect of the internal pipes has an advantage. Compared to the external connected

pipe, the forward load pipe has lower temperatures and further on lower pipe losses because of the energy losses in the tank. Because of quite long running hours of the load loop during one year also in absolute numbers the difference with 179 kWh and 144 kWh respectively is relatively high.

As discussed in several points the internal pipes have a more or less large effect on the performance of the system. In Fig. 4–12 now the impact of the different internal pipes and the different pipe dimensions are shown. Again for the medium sized system (10 m² and 500 liter) the case with internal pipe connections was simulated in several configurations. As base case the heat transfer coefficient of the internal PEX pipe was set to zero. Then the internal load forward pipe was simulated with a PEX 2016 and both boiler pipes still had a UA value of zero. Third step was to set the UA value of the internal load forward pipe again to zero and to simulate both internal boiler pipes with PEX 2016 pipes. Simulation No 4 then was to simulate all three internal pipes with the PEX 2016 pipe. Last but not least all internal pipes were simulated with the PEX 3216 pipe.

As shown in Fig. 4–12 the increase of the auxiliary demand is 1.4 % only for the internal load pipe and 1.5 % only for both internal boiler pipes. All three internal pipes together lead to an increase of the auxiliary demand of 2.2 % when using the 2016 PEX pipe and 1.2 % when using the 3216 PEX pipe.

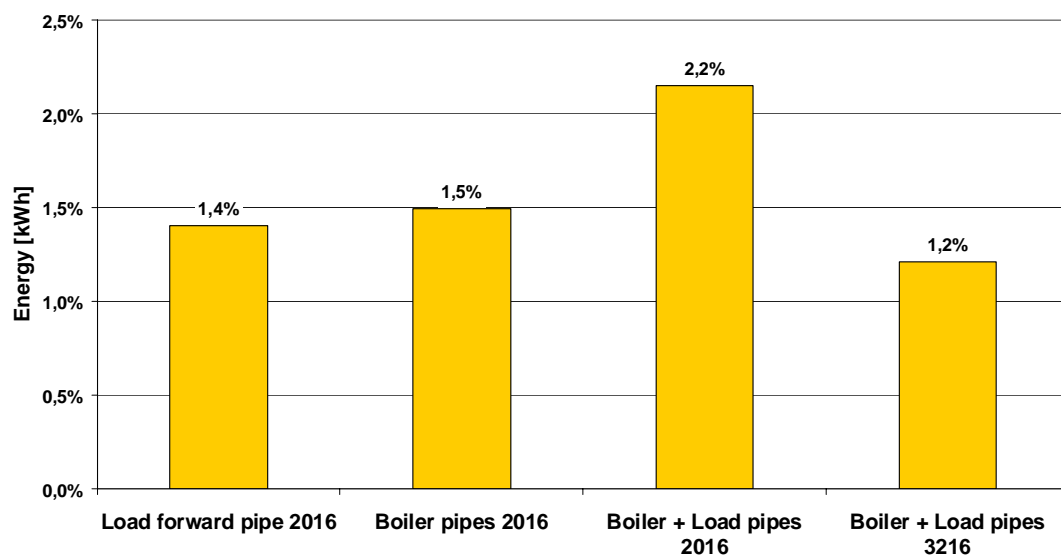

Fig. 4–12 Increase of the auxiliary energy by the effect of different types of internal pipes compared to ideal internal pipes.

The effect of the separate pipes can not be added ($2.2\% < 1.4\% + 1.5\%$). This is the case due to the fact that the first internal pipe leads to some destratification in the tank which reduces the temperature difference between the internal pipes and the water in the tank which of course is the driving force. So adding more and more pipes will influence the system performance not in a linear way.

4.3.4 Conclusions

Two different concepts how to connect the pipes at the tank were investigated for different system sizes. In one concept the pipes are connected at the bottom of the

Annual Calculations

tank and internal PEX pipes with two different dimensions were compared with a concept passing the pipes outside the tank to the right height and connecting them there directly.

The net utilized solar energy between the three different concepts compared to the average varies between -4% and $+2\%$ for the smallest, -2% and $+2.4\%$ for the medium and -2.4% and $+1.4\%$ for the largest sized system. This shows that the type of pipe connections for small systems has the highest influence, decreasing with larger system sizes and higher solar fractions respectively.

Due to the internal load pipe and the internal boiler pipe in the case “Int 2016 pipe” during one year in total 3,165 kWh or 23 % of the heat demand (13,637 kWh) are “used” for destratification with various negative effects on the system performance. In the case “Int 3216 pipe” only 1,206 kWh or 9 % of the heat demand are used for destratification, therefore the negative effects on the system performance are much lower. Because of also positive effects of the cases with internal pipes, mainly due to shorter pipe loops, the overall performances of the concepts with internal pipes are close to (with the 2016 PEX pipe) or better (with the 3216 PEX pipe) than the concept with external pipe connection.

5. Laboratory Experiments

As described previously, the main focus of this solar combisystem concept to achieve low heat losses and high efficiency is to minimize the operating temperature of the whole system. Therefore, during the heating period, the system always operates at the temperature necessary for space heating, which typically is clear below the temperature needed for hot water preparation. The main problem of this concept was therefore to make sure that based on all possible start and boundary conditions hot water preparation performs in a sufficiently good way from the user point of view according to hot water comfort, but also from an energy point of view. This means the system must ensure to achieve the following goals:

- Sufficiently high hot water power
- Sufficiently fast achievement of the hot water set temperature
- Sufficiently stable hot water temperature
- Lowest possible return temperature to the tank

The most critical situation in this system concept (see Fig. 5–1) is during hot water tapping, when the boiler has to start and to deliver heat to the system because the temperature in the tank is not sufficiently high anymore. This quite dynamic process has to be controlled in such a smart way that the hot water temperature is not oscillating too much. In this situation, three components are controlled in a dynamic way, influencing each other quite a lot. These components are the boiler, the mixing valve (V4) and the speed of the pump (P4).

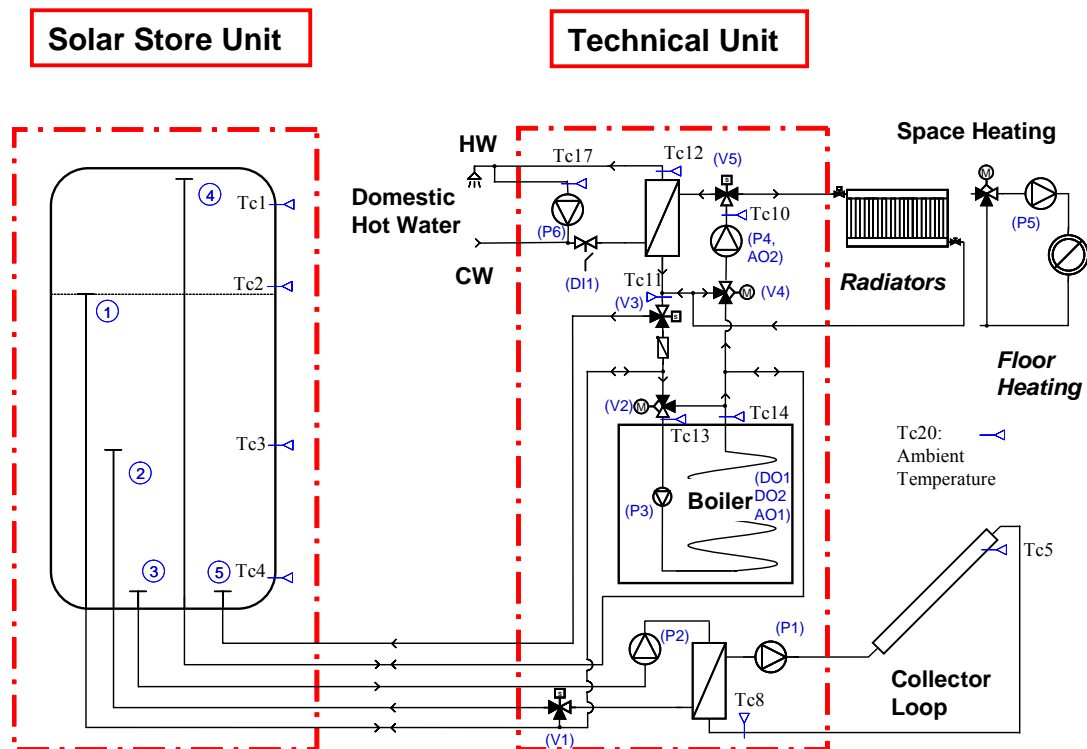

Fig. 5–1 Principle hydraulic scheme of the solar combisystem concept

As a first step it was necessary to find a proper solution to control the speed of a pump (P4) in combination with the available controller. The controller was able to be programmed as a PID-controller and to give two analog voltage control signals between 0 and 10 V for controlling both the pump speed (P4, AO2) and the mixing valve (V4). Therefore the following possibilities were investigated and tested to prepare hot water in combination with a flat plate heat exchanger unit:

- A standard pump (Grundfos UPS 25-60) (Grundfos-A) with constant speed is used in combination with a mixing valve (V4) which controls the primary forward temperature (Tc10) in a way that the tap temperature (Tc12) reaches the set temperature.
- The mixing valve (V4) controls the primary forward temperature (Tc10) to a fixed set temperature (T10_set). The standard pump Grundfos UPE 25-60 (Grundfos-B), which has a standard 0 to 10 V input for speed control, controls the hot water temperature (Tc12) according to the set temperature.
- Again the mixing valve (V4) controls the primary forward temperature (Tc10) to a fixed set temperature (T10_set). The DC pump LAING D5-38/700 B (LAING) is used as a speed controlled pump. For this pump the control signal was a 5 to 0 V signal.
- Finally, again the mixing valve (V4) controls the primary forward temperature (Tc10) to a fixed set temperature (T10_set). A frequency converter (Motron FC750-SP55) (Motron) is used to control the speed of a standard Grundfos UPS 25-60 pump. The 0 to 10 V signal from the controller is translated by this frequency converter to electrical power with a frequency of 5 to 50 Hz, which finally powers the pump.

In order to be able to control the hot water temperature (Tc12) as fast as possible, it is necessary to measure the actual temperature in a way that changes are registered by the controller very fast. For that reason different types of temperature sensors were tested in order to find a simple, cheap, but also good enough solution to measure the temperature fast enough:

- A very thin stainless steel needle is used as sensor pocket reaching inside the flat plate heat exchanger. Inside this needle is a very tiny NTC sensor element with a diameter of about 1 mm. This sensor therefore is reacting very fast.
- A very thin NTC sensor element is clipped on the copper pipe in a way that the sensor has direct contact to the pipe. Due to the very little thermal mass this sensor is reacting very fast.
- A standard NTC sensor packed in a copper cylinder with a diameter of 6 mm is clipped on the copper pipe with a copper clamp resulting in a relatively slow reaction.

After finding the right products for the pump and the temperature sensor, it was necessary to find the best parameter settings for the standard hot water preparation. Additionally for some special situations, also some more advanced control algorithm had to be developed. Finally, the following points were investigated by tests in the laboratory:

- Parameter settings in general and especially for the PID-controllers for the speed controlled pump (P4) and the mixing valve (V4).
- Ensure stable hot water temperature and avoid too high return temperature to the solar tank in cases where the forward temperature on the primary side of the heat

exchanger is not sufficiently high for a period. This mainly happens at the start of hot water tapping and when the boiler has to start due to hot water preparation.

- Optimize stability of hot water temperature in cases with just sufficiently temperature in the tank.
- Ensure to reach the hot water set temperature also for very low flow tapping in combination with the powerful natural gas boiler.

Finally some tests were done to investigate the boiler efficiency in practice as the boiler is integrated in the demonstration system. Based on measurements of the condensation rate at different operation conditions, it was estimated how the hydraulic integration influences the boiler efficiency.

5.1 Hydraulic Strategies for Hot Water Preparation

As it can be seen in Fig. 5–1 (page 69) for hot water preparation based on a “flat plate heat exchanger hot water unit” the hot water in the primary loop has to pass the mixing valve (V4), the pump (P4), the switching valve (V5) and finally the hot water heat exchanger. The main goal of this process is to reach as fast as possible and as stable as possible at the secondary side outlet of the heat exchanger the chosen set temperature (Tc12). For that reason the power on the primary side has to be adjusted to the hot water tap power as fast and as accurate as possible. This can be reached by controlling two parameters at the primary side of the heat exchanger: the flow rate and the forward temperature. Additionally, the forward temperature must be limited to a temperature maximum of about 60°C to avoid deposits of lime stone at the secondary side of the heat exchanger.

Due to the fact that the available controller was only able to use a standard voltage 0 to 10 V signal as an analog control signal for the pump and the mixing valve, it was necessary to find proper solutions and products to achieve the goals. The following four possible solutions were investigated and tested.

5.1.1 Mixing Valve Controls Hot Water Temperature

In this case the pump (P4) is operated with constant speed and the mixing valve (V4) is adapting the forward temperature (Tc10) in a way that the hot water temperature (Tc12) is controlled to the set temperature.

In Fig. 5–2 the result of this strategy is shown based on the data available from the controller. During this test, also the condensing natural gas boiler in parallel is in operation with a forward temperature of about 60 to 65°C. The hot water set temperature is 45°C. The cold water temperature from the mains is about 8°C. The constant primary flow rate forced by the pump (P4) is set to about 530 ltr/h until 23:04 and to about 760 ltr/h until 23:10.

Table 5–1 shows the key figures of the hot water tapping in Fig. 5–2 within the period from 22:43 until 23:07. It can be observed that the return temperature (Tc11) in the cases with low flow rates is very high.

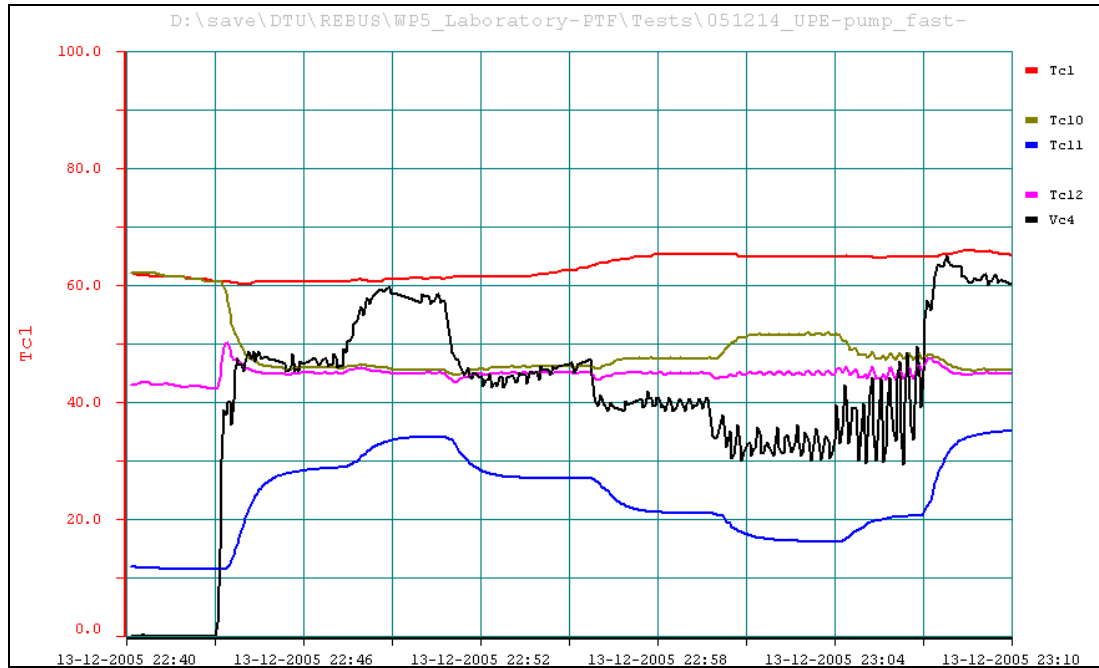

Fig. 5–2 Hot water preparation with constant flow rate and the mixing valve (V4) controls the hot water temperature (Tc12) by changing the forward temperature (Tc10). (Vc4=0% means that the cold inlet of the mixing valve is closed) (Tc1-Tc20 in °C / Vc4 in %).

Table 5–1 Primary flow rate, domestic hot water flow rate, return temperature (Tc11) and domestic hot water power for the period from 22:43 until 23:04.

Time period	Prim. flow [ltr/h]	DHW flow [ltr/h]	DHW flow [ltr/min]	Tc11 [°C]	Power [kW]
22:43–22:47	530	250	4	29	11
22:47–22:51	530	180	3	34	8
22:51–22:56	530	300	5	27	14
22:56–23:00	530	420	7	21	19
23:00–23:04	530	540	9	16	25
23:04–23:07	760	540	9	21	24

Comparing the last two lines (and the equivalent part in Fig. 5–2) shows how strong the flow rate in the primary circuit influences the forward and return temperatures (Tc10) and (Tc11). If this high primary flow rate of 760 ltr/h would be used also for low flow tapping the return temperature (Tc11) would be much higher.

Since flow rates less than 360 ltr/h (6 ltr/min) take place very often, especially when water saving equipment is used, for an efficient solar combisystem, such high return temperatures are not acceptable.

Of course this concept would have the advantage to be able to provide the consumer in a very flexible way also with very high power and with very stable and constant hot water temperature.

5.1.2 Standard AC Speed Controlled Pump

The conclusion of the test results in chapter 5.1.1 is that it is necessary to control the flow rate in the primary circuit in order to get low return temperatures back into the solar tank. The Grundfos UPE 25-60 pump is available on the market as a standard pump which can be speed controlled via an external standard voltage 0 to 10 V signal. Therefore this pump was tested as a next step.

According to the pump specifications, unfortunately, even when the signal for pump speed is set to 5% or less, this pump will operate at a minimum speed of about 1000 rpm. In combination with the hydraulic system of the prototype, this minimum speed leads to a minimum flow rate of about 250 ltr/h. In addition, the voltage signal is not translated linear to pump speed. In fact, the internal electronic controller of the pump is switching stepwise between 20 pump speeds. This is most likely no problem in the range of high speed, but at low speed this fact can cause quite big differences in the flow rate just between one and the other step due to the quadratic pressure drop curve of hydraulic systems.

Fig. 5–3 shows the result of a test with this pump with the following boundary conditions: Hot water set temperature is 45°C. The cold water temperature from the mains is about 8°C. Set temperature difference between primary forward temperature (Tc10) and hot water temperature (Tc12) is 3 K before 12:53 and 5 K after.

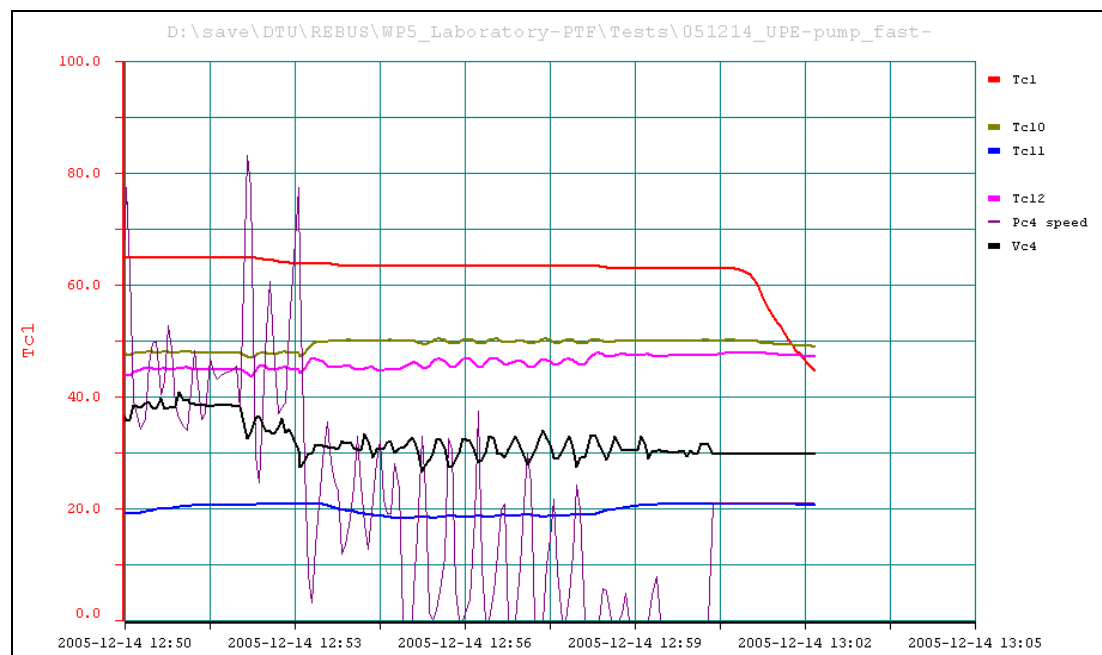

Fig. 5–3 Hot water preparation with the pump UPE 25-60 (Tc1-Tc20 in °C / Vc4 and Pc4_speed in %).

The interesting part is the period between 12:53 and 13:00. From 12:53 until 12:58 the hot water tap flow rate is about 310 ltr/h (5 ltr/min), from 12:58 until 13:00 it is decreased to 200 ltr/h (3 ltr/min). It can be observed that in the first part after a short while the signal for the pump speed (Pc4_speed) goes to zero and starts to oscillate quite strongly between 0 and 30%. This also leads to some oscillation of the tap temperature (Tc12), which would be acceptable with this magnitude.

After reducing the tap flow rate to 200 ltr/h at 12:58, the pump speed goes to zero. But obviously the heating power is still too high because the hot water temperature (Tc12) increases from 45 to about 48°C and the return temperature increases from 19

to about 21°C. This fits to the fact that the minimum flow rate measured before in the primary circuit was about 250 ltr/h.

These tests were done with settings which minimized the problems of instability. It has to be taken in consideration that in practice, customer likes to use a hot water set temperature of up to 55°C instead of 45°C. This leads to more mixing of cold water at the tap to reach the right temperature (e.g. 38 to 40°C for a shower or washing hands) and further on to a reduced hot water flow rate.

Further, the minimum return temperature in this test is 19°C. Compared with the cold water temperature of 8°C from the mains, this is quite high and should be reduced. To achieve a reduction of the return temperature, it is necessary to increase the set temperature difference between primary forward temperature (Tc10) and hot water temperature (Tc12) from 5 to e.g. 7 K. This again leads to the effect that the flow rate in the primary circuit will decrease.

Taking these effects into consideration, it has to be expected that there is a high risk of instability of hot water preparation and too high hot water temperatures because the minimum power in many cases will be too high.

Based on these investigations and conclusions, it was decided to look for better solutions to be able to control the primary flow rate in a better way and to lower values.

5.1.3 Standard DC Speed Controlled Pump

As an alternative to AC pumps, also DC pumps could be used which, in principle, can easier be speed controlled and typically have higher efficiency leading to less electricity consumption. Unfortunately, DC pumps are mainly built for large applications in industry, but not for small heating systems. Therefore only one product was found on the market which potentially could be used: This is the LAING D5-38/700 B (LAING). This pump is powered by 24 V DC and can be controlled via a 5 to 0 V signal. According to the data sheet the maximum pressure at zero flow rate is 320 mbar. This is almost the half of the previously used UPE 25-60 which had a maximum pressure of 600 mbar.

Fig. 5-4 shows the result of a test sequence with this pump with the following boundary conditions: Hot water set temperature is 45°C until 21:53, 50°C until 21:55, 40°C until 22:03 and again 45°C until the end. Set temperature difference between primary forward temperature (Tc10) and hot water temperature (Tc12) is 5 K before 22:50, further 10 K until 22:05 and again 5 K until the end. The cold water temperature from the mains is about 9°C.

Since the signal for pump speed is inverted the controller had to be reprogrammed. Therefore, in the graph if the parameter (Pc4_speed) is 50 %, the speed in fact is the minimum, which is zero. If (Pc4_speed) is 0 % the pump speed is the maximum.

In general it can be observed that the hot water temperature (Tc12) is very stable with only very small oscillations at any temperature level. In addition, when the hot water tap flow rate is changed, the tap temperature (Tc12) is back to set temperature very quick.

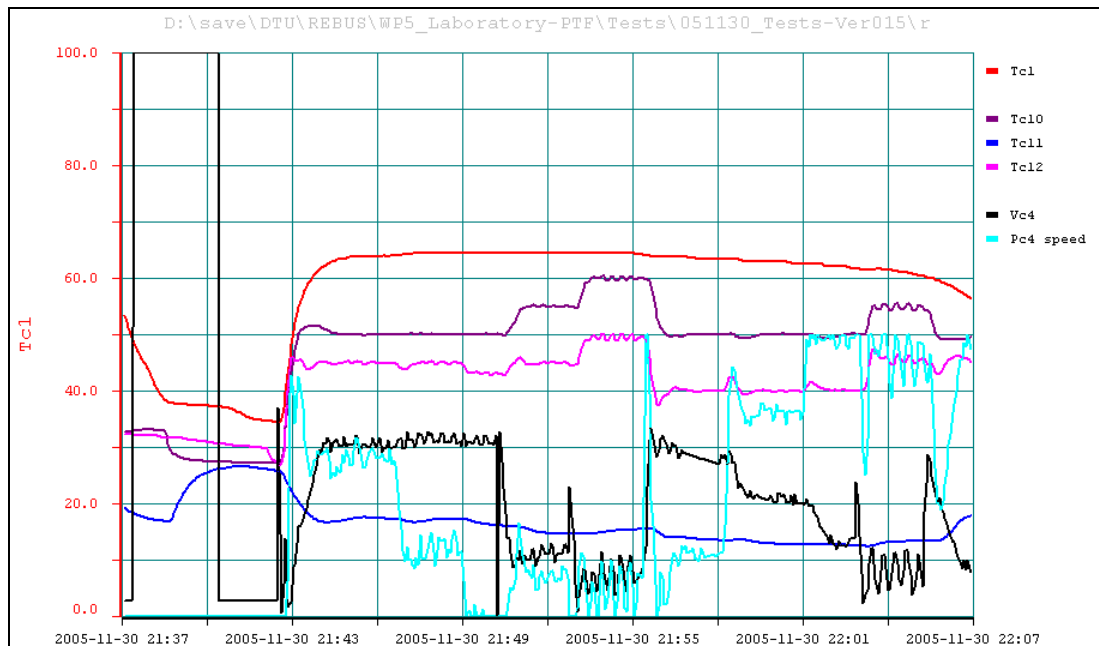

Fig. 5–4 Hot water preparation with the DC pump: LAING D5-38/700 B (Tc1-Tc20 in °C / Vc4 in % / Pc4_speed: 0 = 100 % speed, 50 = 0 % speed).

As it can be seen at 21:49, the signal for pump speed (Pc4_speed) is 0 %, which means that the pump is running full speed. At that time the hot water tap flow rate is 500 ltr/h (8 ltr/min). It can be observed that the hot water temperature slightly decreases from 45 to 43°C, which clearly shows that the maximum power is reached with these settings. After increasing the primary forward temperature from 50 to 55°C at 22:50, the hot water temperature (Tc12) reaches the set temperature of 45°C again and the pump speed is slightly reduced.

At 22:01 the hot water tap flow rate is reduced from 310 ltr/h (5 ltr/min) to 210 ltr/h (3.5 ltr/min) still showing a very stable hot water temperature (Tc12).

In two situations some slightly increased oscillations can be observed: at about 21:54 and at 22:04. In both cases the mixing valve is forced to operate with a signal less than 10 %, which means that only very little cold water is mixed. This shows that for perfect stable operation of the mixing valve, the hot temperature inlet (Tc1) should be 5 to 10 K higher than the set temperature (Tc10). This is additionally strong depending on the flow rate. At high flow rate, the system is more stable than at low flow rate.

Conclusion of these tests: With this pump, hot water preparation can be managed with very high quality, but unfortunately there is one major problem: with this pump the hot water power is limited at about 24 kW, and a larger pump could not be found presently. Reaching a hot water power of about 30 kW with this pump is only possible with a set hot water temperature of 60°C and therefore about 70°C as forward temperature (Tc10) in the primary circuit. For an efficient solar combisystem this temperature level is too high.

5.1.4 Standard AC Pump with Frequency Converter Speed Control

A standard pump (Grundfos UPS 25-60) in combination with a frequency converter (Motron FC750-SP55) could finally be found as a usable solution. The standard voltage 0 to 10 V signal from the controller is translated by this frequency converter

to electrical power with a frequency of 5 to 50Hz, which finally powers the pump. This leads to a range of 300 to 3000 rpm for the pump speed.

In Fig. 5–5 the first test results with the frequency converter are presented which were done without optimized control parameter of the PID controller for the mixing valve (Vc4) and the pump speed (Pc4_speed). The hot water set temperature is 45°C (50°C after 14:27), set temperature difference between primary forward temperature (Tc10) and hot water temperature (Tc12) is 7 K. The cold water temperature from the mains is about 6°C.

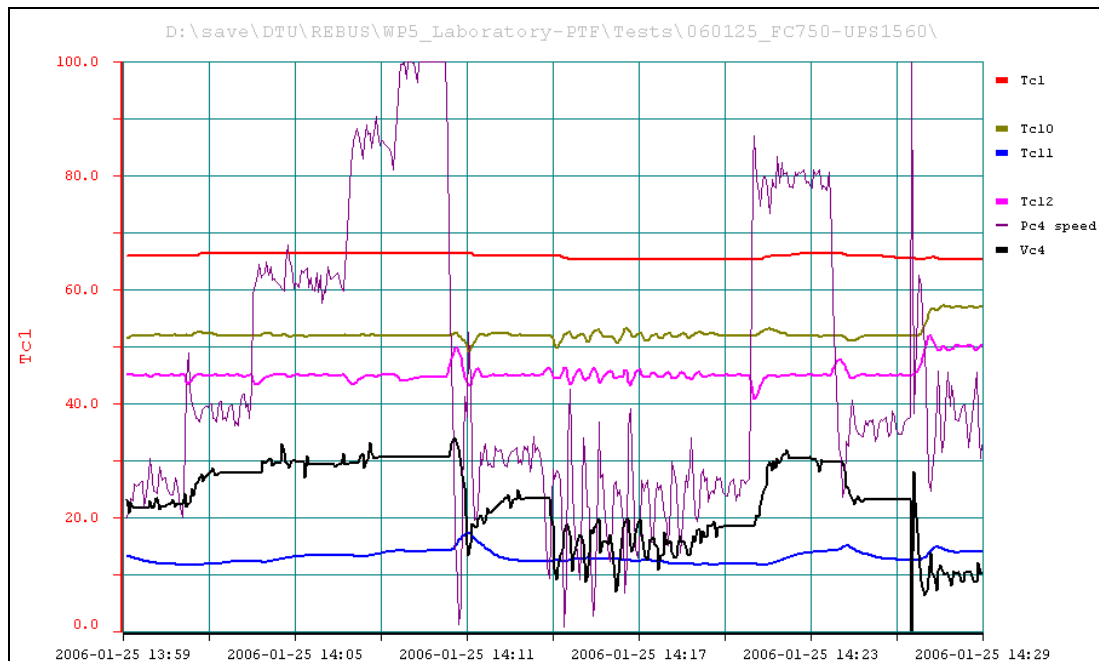

Fig. 5–5 Hot water preparation with the AC pump Grundfos UPS 25-60 in combination with the frequency converter Motron FC750-SP55 (Tc1-Tc20 in °C / Vc4 and Pc4_speed in %).

From 13:59 until 14:10, the hot water tap flow rate was increased step by step from 210 to 300, 460, 600 up to 660 ltr/h (3.5, 5, 7.7, 10, 11 ltr/min). The pump speed (Pc4_speed) is changing fast and obviously also the flow rate changes fast since the hot water temperature (Tc12) is very quick corrected. In addition, the return temperature (Tc11) with these settings is at a constant low level of 11 to 15°C. At the end the hot water flow rate of 660 ltr/h (11 ltr/min) corresponds to a hot water power of about 30 kW at a hot water temperature of 45°C. Therefore hot water power of more than 40 kW is possible without problems, if the hot water set temperature is increased up to 60°C.

At 14:10, the hot water tap flow rate is suddenly reduced from 660 ltr/h to 240 ltr/h which causes a short peak of the hot water temperature (Tc12) by 5 K. At 14:14, an extreme low flow test is done with a tap flow rate of 140 ltr/h (2.3 ltr/min). Even in this situation, the system is able to prepare hot water with oscillations less than ± 2 K. At 14:17, the flow rate was slightly increased to 170 ltr/h (2.8 ltr/min), at 14:18 to 200 ltr/h (3.3 ltr/min).

The reason why this configuration with the frequency converter is operating much better than the one before with the UPE pump, can be explained by comparing the two cases in situations with the same hot water tap flow rate. For 200 ltr/h in Fig. 5–3 at 12:59, the signal for the pump speed (Pc4_speed) is 0 % and the flow rate in the

primary circuit is still too high. In comparison in Fig. 5–5 at 14:20, the signal for the pump speed (Pc4_speed) is about 25 %.

In Fig. 5–3 at 12:54, the signal for the pump speed (Pc4_speed) was in average about 25 % for a hot water tap flow rate of 310 ltr/h. In comparison in Fig. 5–5 at 14:02, the signal for the pump speed (Pc4_speed) is about 38 % for a hot water tap flow rate of 300 ltr/h.

Due to the much larger control range of 300 to 3000 rpm with the frequency converter compared to 1000 to 3000 rpm with the UPE pump it is possible to control the flow rate much better, especially in cases of flow rates less than about 300 ltr/h.

Additionally the UPE pump has a minimum flow rate of about 250 ltr/h (in this system) where, in combination with the frequency converter, the flow rate can be controlled down to almost 0 ltr/h. Therefore, the controlled hydraulic circuit is acting uniformly continuously, where, with the UPE pump due to the minimum flow rate of 250 ltr/h, the hydraulic system is acting discontinuously. For the PID controller it is much easier to control a uniformly continuous acting system than a discontinuous acting system.

Finally it was decided to use this standard UPS 25-60 pump in combination with the frequency converter for further development work on the system and for the demonstration system which was built later as well. Of course it is the goal to find cheaper and more compact solutions in future.

5.2 Different Types of Fast Temperature Sensors

For most of the control tasks within the solar combisystem, temperatures are measured and used in the controller for decisions to switch on/off the pumps or the boiler or to change the position of a switching valve. In most of these cases, there is no need of very fast reacting temperature sensors.

This is different for hot water preparation with the main requirement to prepare hot water with temperature as constant as possible even during strong changes of the tap flow rate. The two temperature sensors that are measuring the primary forward temperature (Tc10) and most important the hot water temperature (Tc12) (see Fig. 5–1 on page 69) need to be quite fast because they are used for hot water preparation.

Three different types were tested to find a proper sensor, which can be used in practice:

- 1) As a very fast type a self built sensor was used as a reference, which in a very similar design in Austria is used for such purpose as well (TA 2006). A very thin and long stainless steel needle is used as a sensor pocket which reaches inside the flat plate heat exchanger. Inside this needle a very tiny NTC sensor element with a diameter of about 1 mm is placed (Fig. 5–6). This sensor has almost no thermal mass and therefore is reacting very fast.



Fig. 5–6 A thin and long stainless steel needle (right) is used as a sensor pocket for a very tiny NTC sensor element (left).

- 2) From the industry partner Metro Therm A/S a special clip-on sensor was proposed. A very thin but robust NTC sensor element is fixed on a plastic part and can be clipped on a pipe in such a way, that the sensor element has a direct contact to the pipe. Due to the very little thermal mass, this sensor also is expected to react very fast.



Fig. 5–7 NTC sensor to be clipped on a pipe

- 3) An advanced standard temperature sensor was proposed from the controller company. The NTC sensor element is packed in a copper cylinder with a diameter of 6 mm and can be clipped on a pipe with a copper clamp that shall ensure good thermal contact. The copper clamp is soldered to the cylinder to ensure good thermal contact here as well.

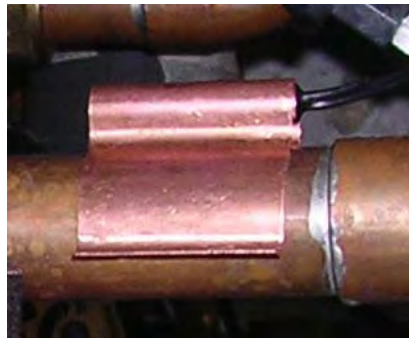

Fig. 5–8 Advanced standard sensor based on a NTC element in a copper cylinder with a copper clamp to be clipped on a pipe.

For testing these three temperature sensors, a step function test was planned to be done in the laboratory directly on the prototype. All three sensors were mounted on the system as shown in Fig. 5–9. The first sensor (1) was connected to the controller and used for hot water preparation. The two other sensors were just connected to the controller for data logging.

Fig. 5–10 shows the results of the test. At the beginning, the pump (Pc4) was switched off and hot water tapping was started. Therefore, all the pipes and the hot water heat exchanger were cooled down to the mains cold water temperature of about 5°C. After starting the pump, it can be observed that the temperature sensors (Tc12) and (Tc9) increased very quickly, sensor (Tc17) reacted much slower. At 17:05 the tapping was stopped and the pump switched off. At about 17:06 tapping was started again to cool the system very fast.

The conclusion of this test is that sensor (1) and sensor (2) are reacting very fast in the step function test in both cases when heating up and cooling down. Sensor (3) is reacting much slower.

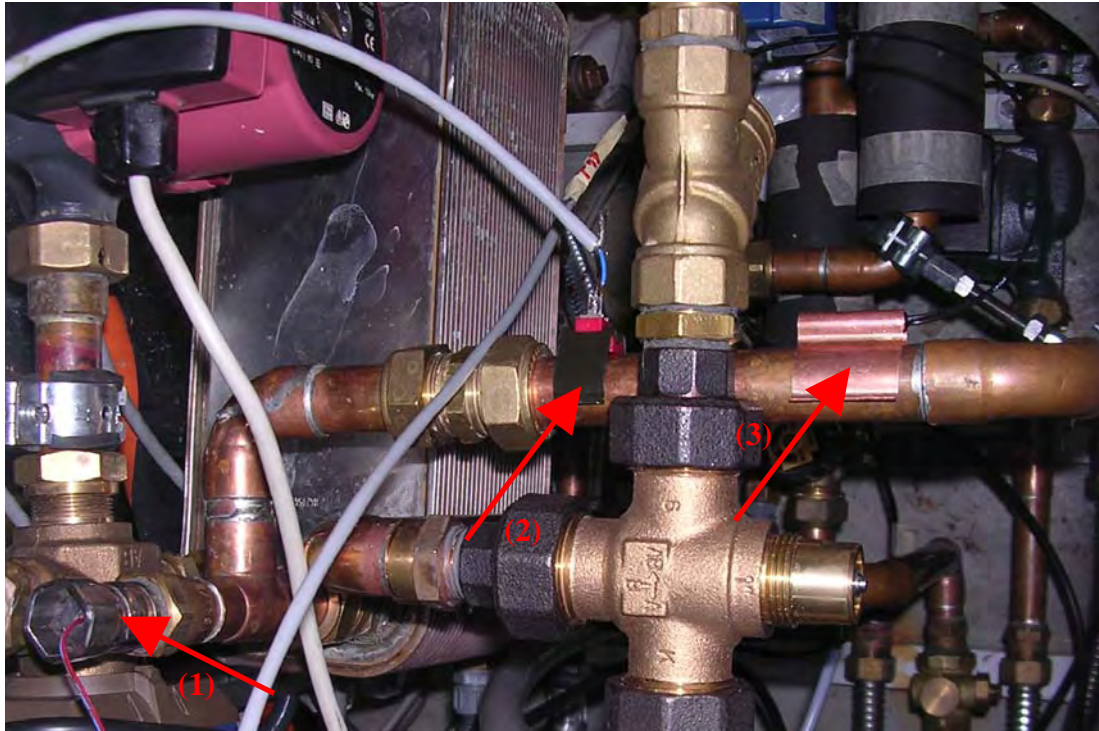

Fig. 5–9 The three possible different temperature sensors tested to be used as the sensor Tc12: 1) thin stainless steel needle as sensor pocket reaching into the hot water heat exchanger (Tc12); 2) thin NTC sensor element with direct contact on the pipe (Tc9); 3) standard NTC sensor in a copper cylinder with copper clamp (Tc17).

The absolute temperature measured by sensor (2) at temperatures higher than ambient temperature is slightly lower compared to sensors (1) and (3). This is because sensor (2) is not protected against the ambient air and therefore relatively high heat losses lead to this error. Sensor (1) is mounted in a very long (about 150 mm) sensor socket, which is flushed by the hot water and therefore measuring the temperature more accurate.

In order to prepare hot water with only little oscillations fast reaction of a temperature sensor is the most important characteristic. A small error of the absolute value can easily be corrected by a calibration function, if necessary.

Since the temperature sensor (2) compared to sensor (1) is available as a standard product on the market and also very easy to handle in practice, it was decided to use sensor (2). The temperature sensor (3) can be used for all other applications, but for fast and dynamic tasks this sensor is reacting too slowly.

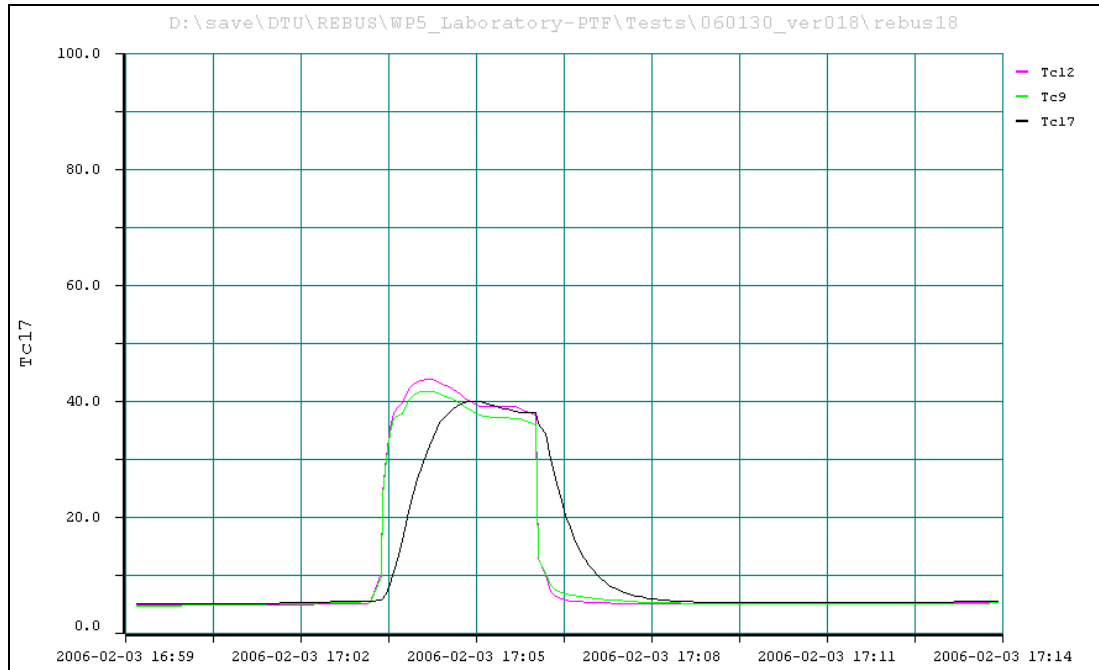

Fig. 5–10 Three possible different temperature sensors tested with a step function response: (Tc12) thin stainless steel needle as sensor pocket reaching into the heat exchanger; (Tc9) thin NTC sensor element with direct contact on the pipe; (Tc17) standard NTC sensor in a copper cylinder with copper clamp (Tc1-Tc20 in °C).

5.3 Control Algorithm for Hot Water Preparation

Based on the basic principle of this concept the hot water preparation is the key task which has to be managed in all cases. Since the set temperature of the auxiliary volume in the solar tank for space heating is lower than for domestic hot water preparation, four different cases of hot water preparation can take place:

1. Hot water preparation without boiler
2. Hot water preparation with boiler switching on during tapping
3. Hot water preparation with boiler from start
4. Hot water preparation with boiler and very low tap flow

The main task is to make sure that the hot water temperature is kept as constant as possible during all operation conditions. To achieve this goal, in the controller of the solar combisystem a PID controller was programmed for both the mixing valve (Vc4) and the speed of the pump P4 (Pc4_speed). Based on experiments in the laboratory and experience in practice from the demonstration house, the correct parameters were elaborated and the control algorithm was adapted and improved step by step.

In the following graphs of this chapter 5.3, in all cases the hot water set temperature (Tc12) is 50°C, except Fig. 5–15 where the set temperature is 45°C. The set temperature for the primary forward temperature (Tc10) in general is 57°C, but in many cases this is overruled due to specific reasons, which will be explained. During space heating the speed of the pump (Pc4_speed) is set to 50%.

5.3.1 Hot Water without Boiler

The standard case in summer time should be that the solar tank is heated to sufficient high temperature by solar energy to be able to prepare hot water. In this case the mixing valve (Vc4) is necessary to control the primary forward temperature (Tc10) to a specified set temperature of about 5 to 10 K higher than the hot water set temperature. This is necessary due to two reasons:

1. If the primary forward temperature (Tc10) is controlled to about 5 to 10 K higher than the hot water set temperature, the system is able to control the primary flow rate in a wide range according to the hot water tap flow rate. If the temperature (Tc10) would be much higher, the range of the primary flow rate, which could be used to adapt the power, would be very low and therefore not easy to be controlled in a proper way by the PID controller.
2. If the primary forward temperature (Tc10) is higher than 60°C, the risk of lime deposit at the secondary side of the plate heat exchanger (fresh water side) is increasing dramatically.

In Fig. 5–11 two examples of a hot water tapping in summertime are shown, where the top temperature in the solar tank (Tc1) and (Tc2) is about 75°C. The initial position of the mixing valve (Vc4) is 0% when the hot water tapping starts. The pump speed (Pc4_speed) immediately is increasing to very high values in order to heat up the heat exchanger as fast as possible. As it can be seen, as soon as the primary forward temperature (Tc10) is increasing very quickly, the signal for the mixing valve (Vc4) also is almost jumping to about 35%. After a short time when the set temperatures for (Tc12) and (Tc10) are almost reached (50°C and 57°C respectively), both the pump speed (Pc4_speed) and the mixing valve signal (Vc4) are adjusted very quick again.

As a result it can be observed that both the primary forward temperature (Tc10) and the hot water temperature (Tc12) reach their set temperatures very fast and keep them also very constant. Also the primary return temperature (Tc11) decreases very fast to a low level of about 22°C, which is a good result in comparison with the fresh cold water temperature of about 16°C from the mains at that time.

As it can be observed in Fig. 5–12 the result of this example is not looking as perfect as before. The difference is the much lower temperature in the top of the solar tank (Tc1). The temperature in the tank is just sufficient high to reach the set forward temperature (Tc10). Also a small influence has the fact, that the start temperature of (Tc10) before was 40°C and here it is only 30°C.

The PID controller for the mixing valve (Vc4) does not know that finally it is not necessary to mix cold water to reach the set temperature at (Tc10). Therefore, the mixing valve in the beginning starts mixing in order to avoid overshooting. Since the temperature in the tank is not very high, the result is a relative slow increase of the primary forward temperature (Tc10), which is forcing the PID controller of the pump (Pc4_speed) to run at 100% for a while in order to reach as fast as possible the hot water set temperature of 50°C at the sensor (Tc12).

Beside a longer waiting time and a small overshooting of the hot water temperature, the biggest disadvantage is the relative high primary return temperature (Tc11) of about 30° for about one minute before it drops again to about 22°C.

Laboratory Experiments

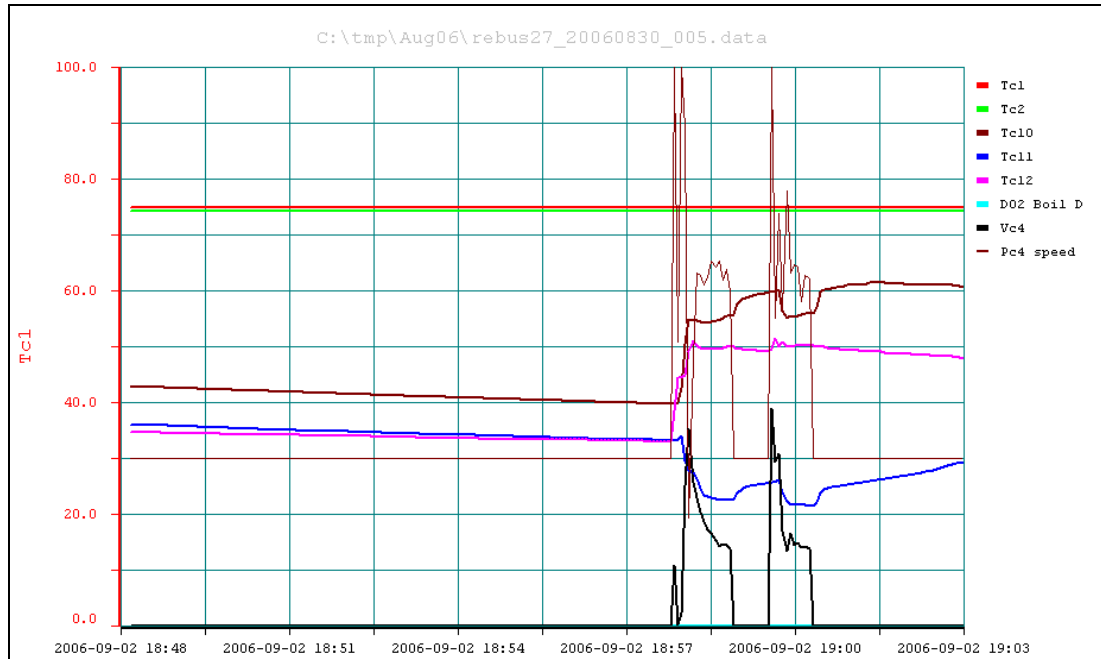

Fig. 5–11 Hot water preparation with high temperature in the solar tank (Tc1-Tc20 in °C / Vc4 and Pc4_speed in % / DO2_Boil_D is an on/off signal).

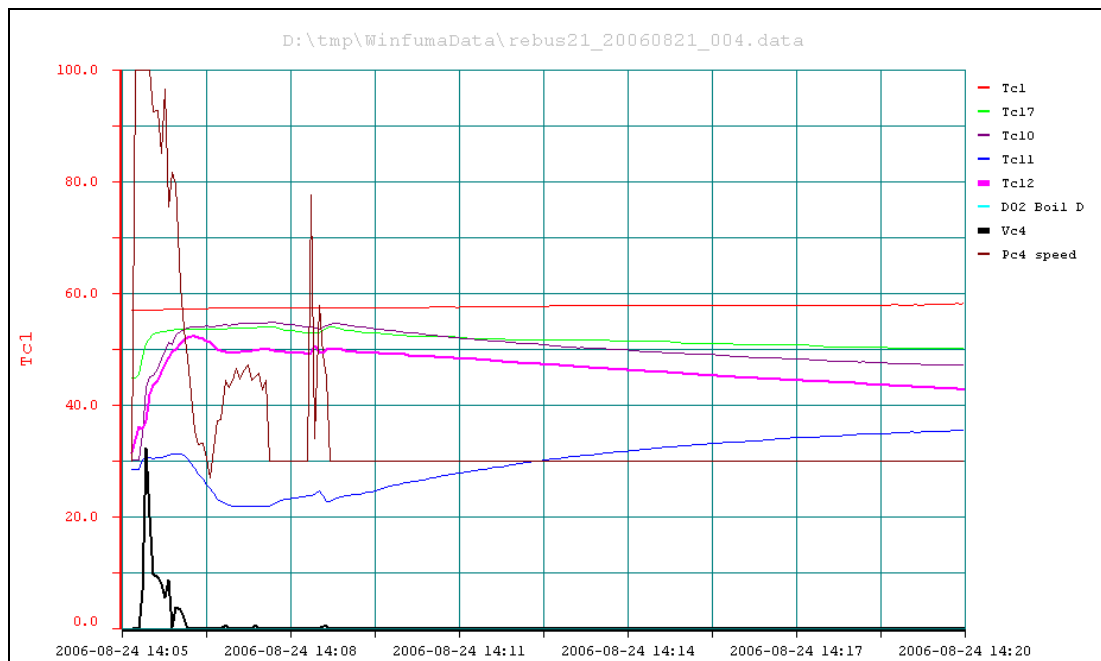

Fig. 5–12 Hot water preparation with just sufficient high temperature in the solar tank and first approach of controlling pump speed (Pc4_speed) and mixing valve (V4) leading to high return temperature (Tc11) in the beginning (Tc1-Tc20 in °C / Vc4 and Pc4_speed in % / DO2_Boil_D is an on/off signal).

Also in Fig. 5–13 a similar start situation is shown but with slightly different behavior. In this case after start of hot water tapping both the primary forward temperature (Tc10) and the hot water temperature (Tc12) are increasing very fast. But the PID controllers of both the mixing valve (Vc4) and the pump speed (Pc4_speed) are oscillating for a while quite strong until they find stable positions.

This leads to oscillating hot water tap temperature (Tc12) and too high primary return temperature (Tc11).

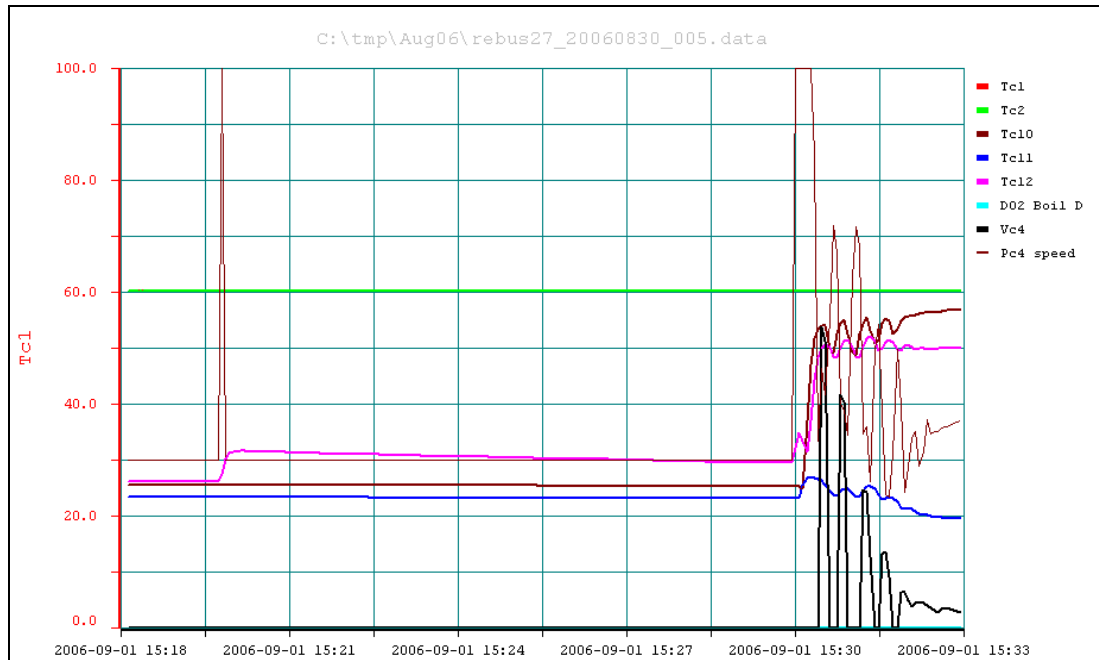

Fig. 5–13 Hot water preparation with just sufficient high temperature in the solar tank and first approach of controlling pump speed (Pc4_speed) and mixing valve (V4) leading to very unstable tap temperature (Tc12) in the beginning (Tc1-Tc20 in °C / Vc4 and Pc4_speed in % / DO2_Boil_D is an on/off signal).

5.3.2 Improved Control of Pump Speed and Mixing Valve

An analysis of the last two figures shows that it is a problem for the system to reach the set position fast and to keep it stable if the inlet temperature at the hot side of the mixing valve (Vc4) is too close to the set temperature at the outlet. In order to improve such situations the following two strategies were introduced:

1. Based on the difference between the actual top tank temperature (Tc1) and the primary forward set temperature (Tc10) the mixing valve (Vc4) is in use or not. If this difference ($Tc1 - Tc10$) is less than 12 K and Tc1 is less than 62°C (to avoid lime problems) the mixing valve (Vc4) immediately is set to 0%.
2. Based on the difference between the set value and the actual value of the primary forward set temperature (Tc10) the pump speed is damped depending on the magnitude of this difference. The maximum damping factor is 50% to avoid “no flow”.

After introducing these two strategies the system is able to react much better on the boundary conditions as it can be observed in Fig. 5–14. When hot water tapping starts, the signal for the mixing valve (Vc4) immediately drops to 0%, which leads to a fast increase of the primary forward temperature (Tc10). Due to the damping effect for the pump speed (Pc4_speed) also the primary return temperature (Tc11) is dropping immediately almost to the final temperature level. Also due to the damping effect on the pump speed the hot water temperature (Tc12) is overshooting less.

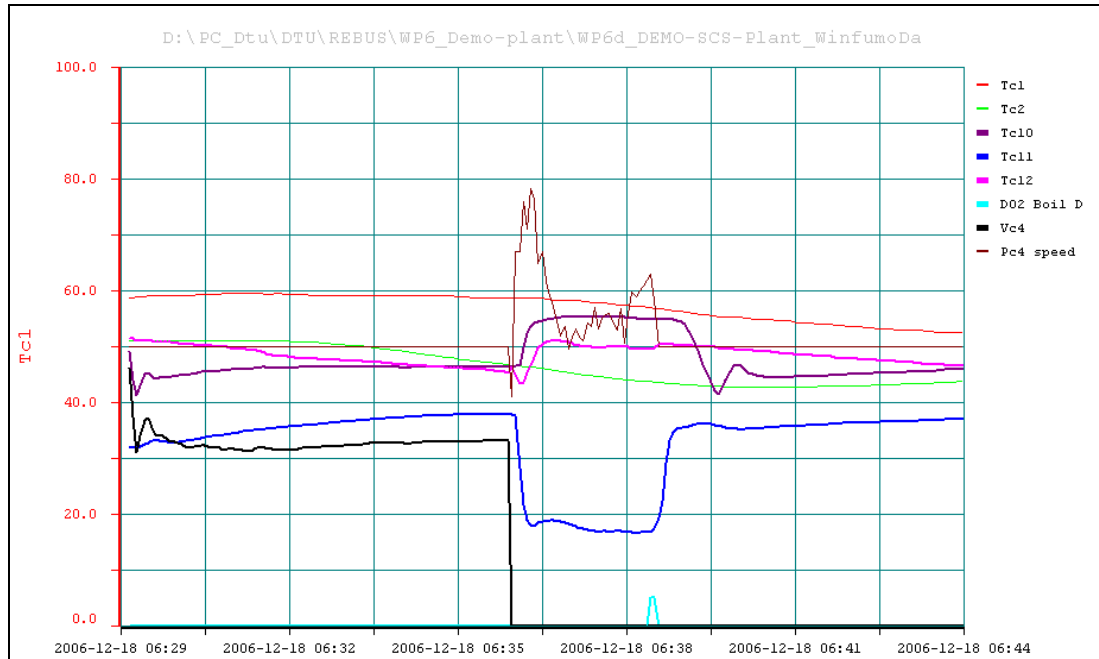

Fig. 5–14 Hot water preparation with just sufficient high temperature in the solar tank and advanced approach of controlling pump speed (Pc4_speed) and mixing valve (V4) leading to fast approach of set tap temperature (Tc12) and low return temperature (Tc11) from the beginning (Tc1-Tc20 in °C / Vc4 and Pc4_speed in % / DO2_Boil_D is an on/off signal).

5.3.3 Hot Water with Boiler Start during Tapping

The most critical situation takes place when during hot water tapping the temperature in the top of the solar tank falls below the set temperature, which is needed for hot water preparation. In this case the boiler immediately must take over the heat supply. In fact it takes some time until the boiler is able to deliver heat at the right temperature. First the following start procedure must be executed. After getting the signal to start, the internal controller of the boiler is starting the internal boiler pump, running the start security procedure in the burner (flushing the burner with fresh air to avoid explosion) and finally ignition takes place and the boiler starts to produce heat.

In Fig. 5–15 one of the first test results for this case is presented in the period from 23:11 until 23:19. Hot water tap flow rate is about 450 ltr/h. Hot water set temperature (Tc12) is 45°C and the set temperature for the primary forward temperature (Tc10) is 47°C. Due to this very small difference of 2 K the primary flow rate is forced to be relative high and therefore large changes of the pump speed (Pc4_speed) are possible for adjusting the power, which is transferred by the hot water plate heat exchanger. The disadvantage of high return temperature (Tc11) in this test is neglected. Further, the 3-way valve (Vc2) did not exist during this test (see Fig. 5–1 on page 69). At about 23:15 manually the boiler was switched on resulting in a quite large oscillation of the hot water temperature (Tc12) of ± 7 K. Due to the fact that the boiler was initially warm from previous tests and the set hot water temperature is relative low this result is one of the best which could be achieved with this hydraulic configuration without the valve V2. In cases with initially cold boiler from the start, the hot water temperature could get negative peaks of -15 K from set temperature. Such oscillations are not acceptable from a comfort point of view.

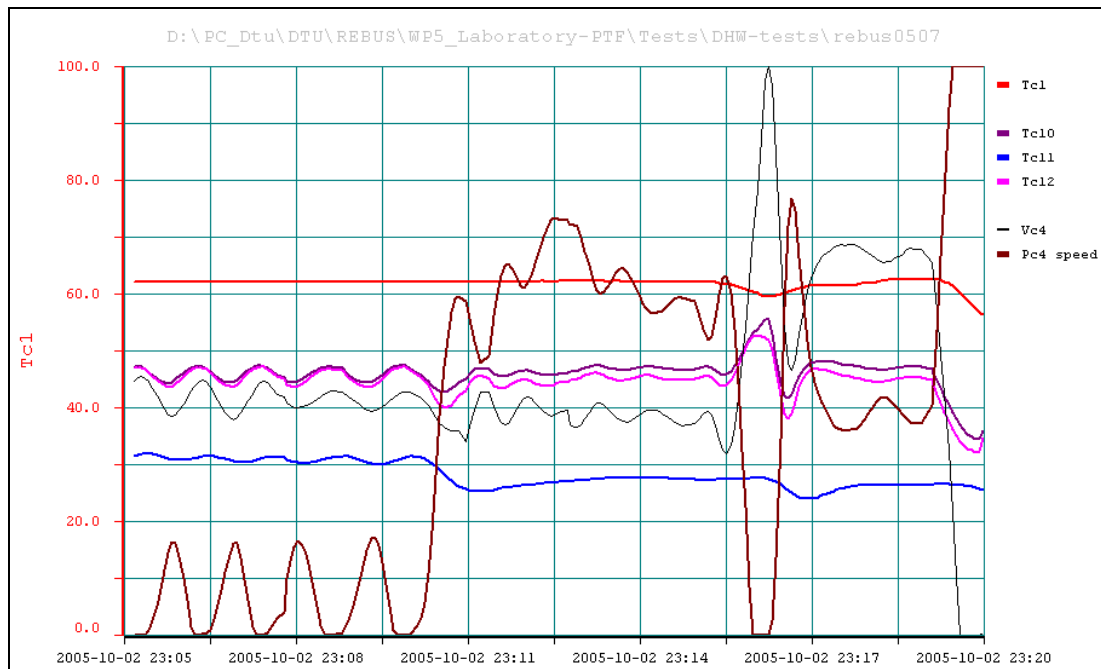

Fig. 5–15 Hot water preparation with boiler starting during tapping. Example of first tests with an initially warm boiler (Tc1-Tc20 in °C / Vc4 and Pc4_speed in %).

In order to solve this problem the 3-way valve (V2) was introduced. This valve is used to preheat first the boiler loop until the set temperature is reached. When this valve opens after the right time period, the boiler forward temperature is close enough to the primary forward set temperature (Tc10) that the PID controller of the pump (Pc4_speed) is able to do the small corrections in order to minimize the oscillations of the hot water temperature (Tc12) to an acceptable magnitude.

In this solar combisystem concept in combination with a pellet boiler the 3-way valve V2 anyway is needed to increase the boiler return temperature (Tc13) up to about 57°C, which is necessary to avoid corrosion due to condensation in the pellet boiler.

The advanced control algorithm (see chapter 5.3.2 on page 83) for the mixing valve (Vc4) was extended in a way that the signal (Vc4) is set to 0% as soon as the boiler is switched on. Since the boiler set temperature for hot water preparation can be chosen properly (here about 62°C), there is no need for controlling the mixing valve. Much more this reduces oscillations of the hot water temperature (Tc12) very effective.

In Fig. 5–16 the behavior of the system is shown after adding the 3-way valve V2 and finding the right control algorithm how to control it.

In this case at that time the previous described damping function for the pump speed was not introduced. The effect can be seen at the start of the hot water tapping where the return temperature (Tc11) for a period is increasing before it drops to about 20°C. When the top temperature in the solar tank (Tc1) decreases to less than 57°C, the boiler gets the signal to switch on (DO2_Boil_D). After a short time the boiler return temperature (Tc13) increases until the 3-way valve V2 opens. Now the primary forward temperature (Tc10) immediately increases as well. Since the boiler return temperature (Tc13) very fast is dropping also (Tc10) is dropping because the boiler is not able to react that fast. But after a short period the boiler has adapted the power to reach the set temperature. Due to the fast reacting PID controller the pump speed

(Pc4_speed) is adapted that fast, that the oscillation of the hot water temperature (Tc12) is damped to less than ± 2 K.

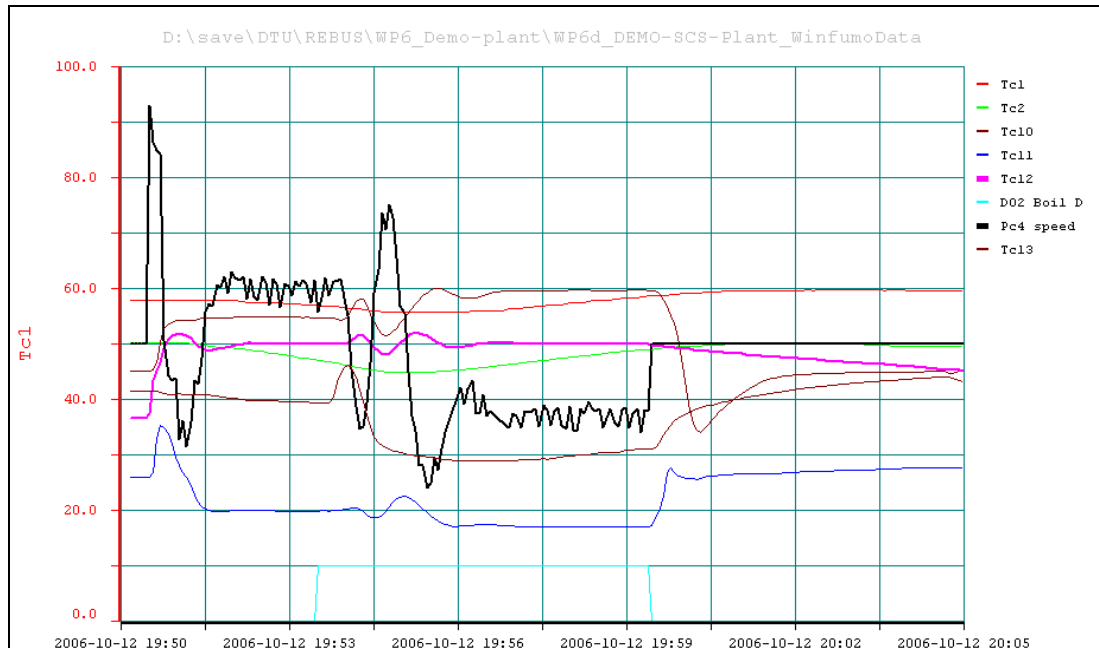

Fig. 5–16 Hot water preparation with boiler starting during tapping with the final control algorithm for the 3-way valve (Vc2) (Tc1-Tc20 in °C / Pc4_speed in % / DO2_Boil_D is an on/off signal).

5.3.4 Hot Water with Boiler from Start

During the heating season the standard case most likely is that due to space heating demand the temperature in the top of the solar tank is only heated up to the set temperature for space heating. Depending on the ambient temperature this is a temperature typically between 35 and 60°C where the upper temperature is necessary only very seldom. If the hot water set temperature is 45 to 50°C, the primary forward temperature (Tc10) must be at least 52 to 57°C. Therefore most of the time during the heating season the boiler needs to start when hot water tapping takes place.

In Fig. 5–17 a typical short hot water tapping in the morning is shown. Before hot water tapping starts, the system is operating as a space heating system with 45°C set forward temperature (Tc10). Immediately after start of hot water tapping the mixing valve (Vc4) is set to 0% and the forward temperature (Tc10) and the hot water temperature (Tc12) are increasing. There is a little discontinuation in the temperature devolution due to the fact that the boiler did not reach the set temperature immediately. At that time the speed control of the pump (Pc4_speed) was not damped yet, therefore it can be observed again that the primary return temperature (Tc11) is increasing quite strong up to 37°C before it drops to finally about 19°C. Also the hot water temperature (Tc12) is overshooting by about 3 K due to the full speed of the pump in the beginning.

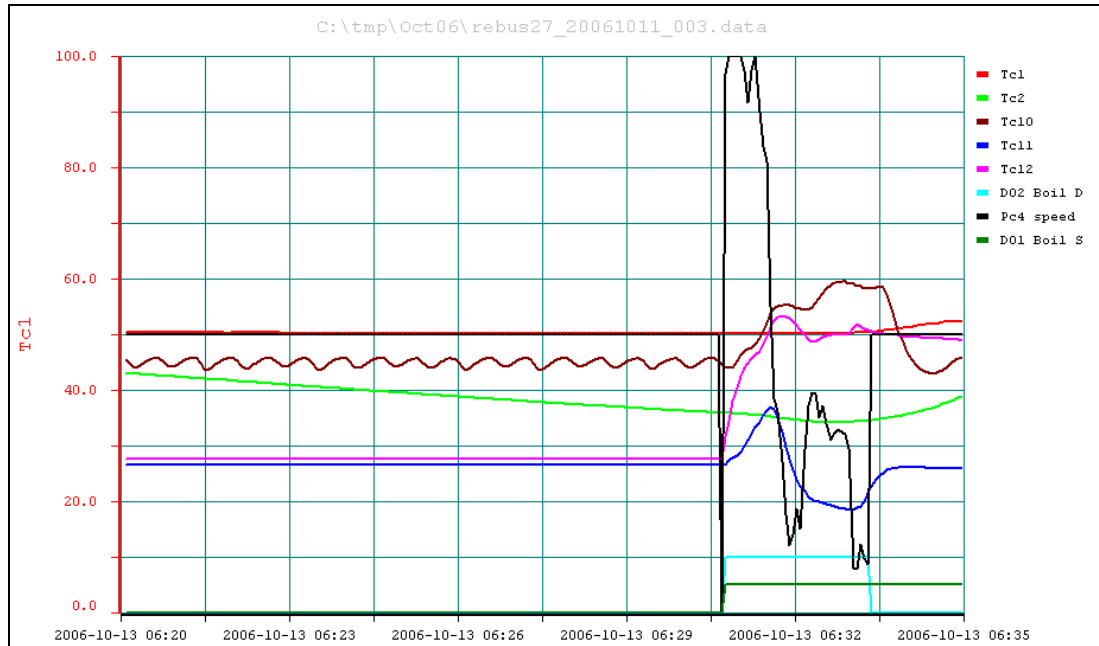

Fig. 5–17 Hot water preparation with boiler from the start and full speed control of the pump (Pc4_speed) (Tc1-Tc20 in °C / Pc4_speed in % / DO1_Boil_S and DO2_Boil_D are on/off signals).

In Fig. 5–18 two hot water tapplings are shown where the damping function for the pump speed (Pc4_speed) was introduced. Before the first tapping starts, space heating was in operation with 45°C forward temperature (Tc10) and the hot water heat exchanger was cold.

In comparison to the figure before, now the pump speed is damped, therefore the signal (Pc4_speed) is just exceeding 70% as a maximum. This leads to an only negligible slower increase of the hot water temperature (Tc12) but also to an immediately and much faster dropping of the return temperature (Tc11). Also the overshooting of the hot water temperature (Tc12) is much less.

Due to this long hot water tapping of almost five minutes the top of the tank (Tc1) in parallel was heated to about 58°C by the boiler. Therefore the next hot water tapping could start without starting the boiler immediately. When the primary forward temperature (Tc10) increased again from space heating level to about 55°C, also the hot water temperature (Tc12) followed immediately with only very little overshooting. The return temperature (Tc11) immediately dropped to less than 20°C. About one minute after start of hot water tapping it was necessary to start the boiler again (DO1_Boil_D).

The devolution of the hot water temperature (Tc12) shows a very constant and stable behavior with just some small oscillations of about ± 1.5 K during this process of switching on the boiler.

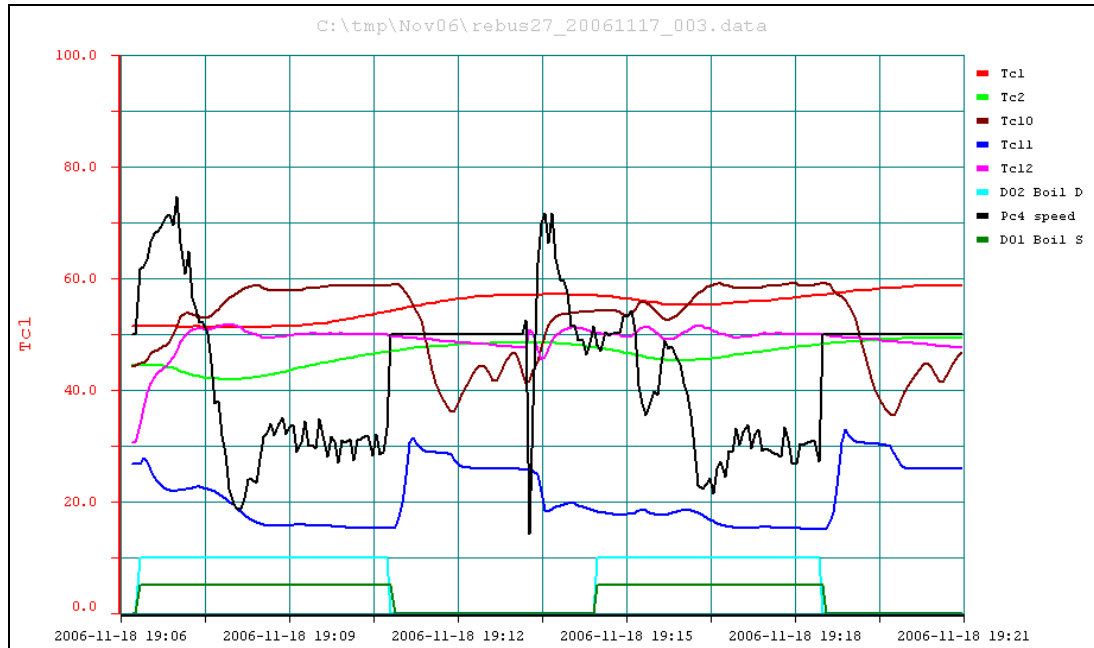

Fig. 5–18 Hot water preparation with boiler from the start (first tapping) with the damped control algorithm for the speed controlled pump (Pc4_speed) (Tc1-Tc20 in °C / Pc4_speed in % / DO1_Boil_S and DO2_Boil_D are on/off signals).

5.3.5 Hot Water with Previous operating Boiler from Start

If hot water tapping occurs when the boiler is in operation in space heating mode (Do1_Boil_S), the boiler just has to switch to domestic hot water mode (DO2_Boil_D) and increase the temperature.

As it can be observed in Fig. 5–19, unfortunately the internal controller of this boiler type is first decreasing the forward temperature (Tc10) before the new set temperature is achieved. Therefore the devolution of the hot water temperature makes a rest at about 44°C before it further increases. In this case again the damping function for the pump speed control (Pc4_speed) is not available, which leads to quite a large overshooting of the hot water temperature (Tc12). Much worse is the increase of the return temperature (Tc11) up to 35°C before dropping to the final temperature of less than 20°C which takes about 90 seconds since the start of hot water tapping.

In comparison in Fig. 5–20 a similar situation is shown where the damping function for the pump speed (Pc4_speed) is used. When the forward temperature (Tc10) is decreasing, due to the damping function also the pump speed signal (Pc4_speed) is decreasing. This leads to a marginal lower hot water temperature (Tc12) in the start phase but also to less strong overshooting later. The real advantage is the much better behavior of the return temperature (Tc11), which is immediately dropping to 20°C and further less.

According to the energy meter, which has the temperature sensor mounted without a sensor socket direct in the cold water pipe, the mains cold water temperature on November 8th, 2006 was 12°C. This shows that this system is preparing hot water in an excellent way, leading to very low return temperatures to the solar tank, which are important for good thermal stratification what is the basis for a high overall system performance.

Laboratory Experiments

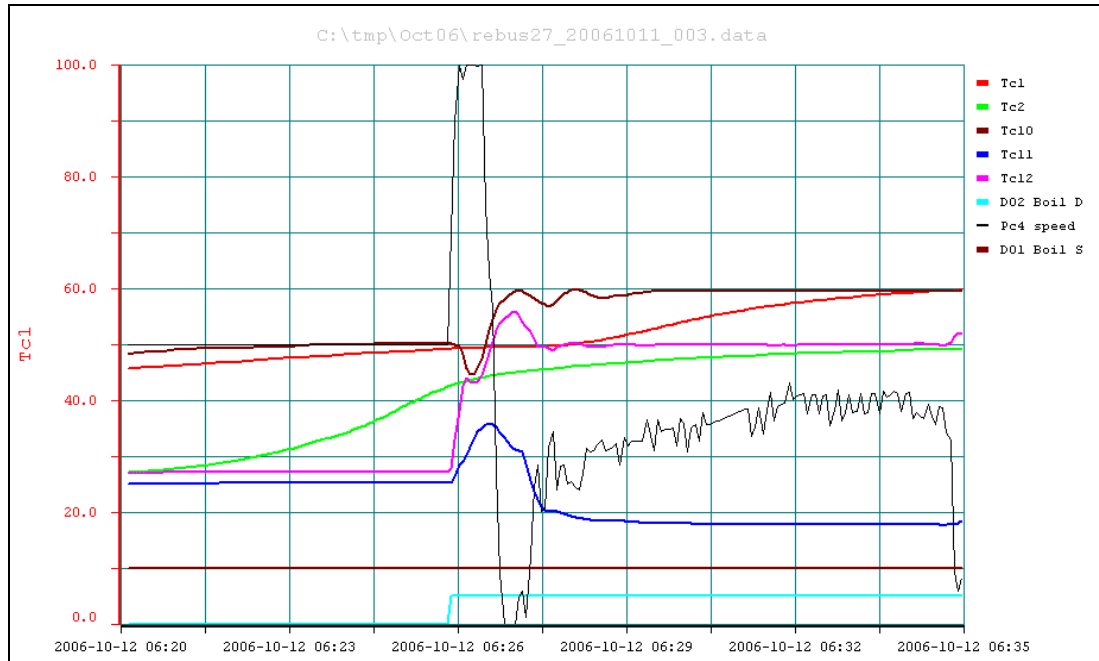

Fig. 5–19 Hot water preparation with previous operating boiler and full speed control of the pump (Pc4_speed) (Tc1-Tc20 in °C / Pc4_speed in % / DO1_Boil_S and DO2_Boil_D are on/off signals).

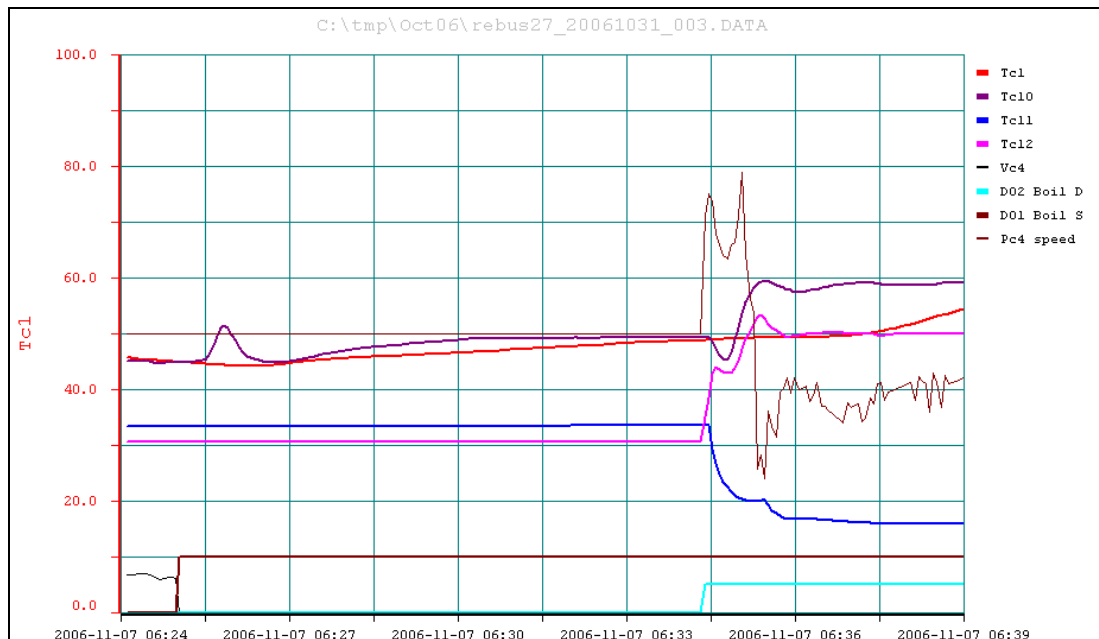

Fig. 5–20 Hot water preparation with previous operating boiler and the damped control algorithm for the speed controlled pump (Pc4_speed) (Tc1-Tc20 in °C / Vc4 and Pc4_speed in % / DO1_Boil_S and DO2_Boil_D are on/off signals).

5.3.6 Hot Water with Boiler and Very Low Tap Flow

During the measurements in the demonstration house the problem of very low hot water tap flow in combination with the boiler came up. In Fig. 5–21 the problem can be observed. Even with pump speed set to 0% (Pc4_speed) the hot water temperature

(Tc12) exceeded the set temperature of 50°C, it reached the same temperature as the primary forward temperature (Tc10) of about 60°C.

Due to the hydraulic design (see Fig. 5–1 on page 69) of course a parallel flow occurs. Depending on the pressure drop one part of the boiler forward flow goes directly into the tank via pipe 4. The remaining part of the flow passes the hot water flat plate heat exchanger and depending on the temperature (Tc11) via the 3-way valve V3 and pipe 1 into the tank or direct back into the boiler. It was expected that the pressure drop of the flat plate heat exchanger is that high, that even at very low hot water demand the pump would be necessary to provide a high enough flow passing the heat exchanger. But practical experience showed that at hot water tap flow rates of less than 180 ltr/h (3 ltr/min) the primary flow rate was too high even when the pump speed was set to 0%.

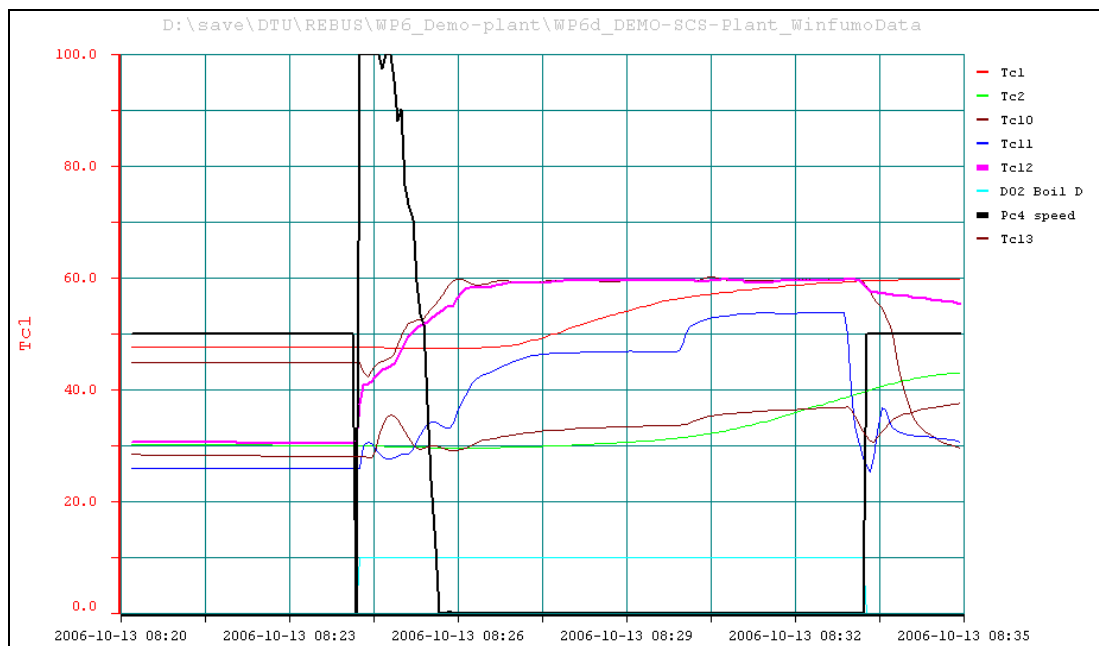

Fig. 5–21 Hot water preparation with boiler from start and very low hot water tap flow rate with previous standard control algorithm (Tc1-Tc20 in °C / Pc4_speed in % / DO2_Boil_D is an on/off signal).

The problem was solved by introducing a control algorithm which is opening the bypass of the 3-way valve V2 (see Fig. 5–1 on page 69) a little, if the pump speed signal (Pc4_speed) decreases to less than 1%.

Fig. 5–22 shows how this strategy works. As soon as the pump speed signal (Pc4_speed) goes below 1% the valve V2 opens with the result that the boiler return temperature (Tc13) increases. This is resulting in an oscillating system behavior with quite strong amplitudes of the boiler forward temperature (Tc10) but only very little amplitudes for the hot water temperature (Tc12). Beside the speed control of the pump, at such a low hot water tap flow rate also the thermal mass of the plate heat exchanger has a quite strong damping effect which leads to the constant hot water temperature.

In Fig. 5–23 a hot water tapping is shown where in the beginning the hot water tap flow rate was quite large, forcing the pump to run at a high speed of 60% (Pc4_speed). After a while suddenly the tap flow rate dramatically drops and therefore forcing also the pump speed (Pc4_speed) to reduce to 0%. Until the end of

Laboratory Experiments

the hot water tapping due to frequently short openings of the valve V2 the system is kept in a slightly oscillating operation mode.

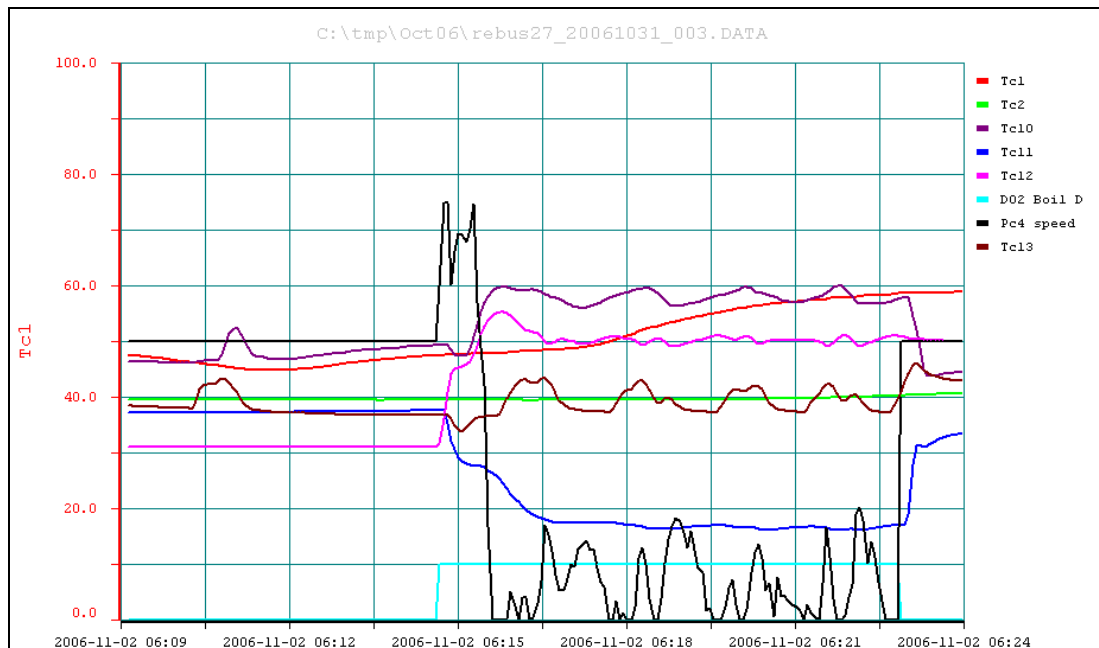

Fig. 5–22 Hot water preparation with boiler from start and very low hot water tap flow rate with the final control algorithm to avoid overheating of hot water temperature (Tc12) (Tc1-Tc20 in °C / Pc4_speed in % / DO2_Boil_D is an on/off signal).

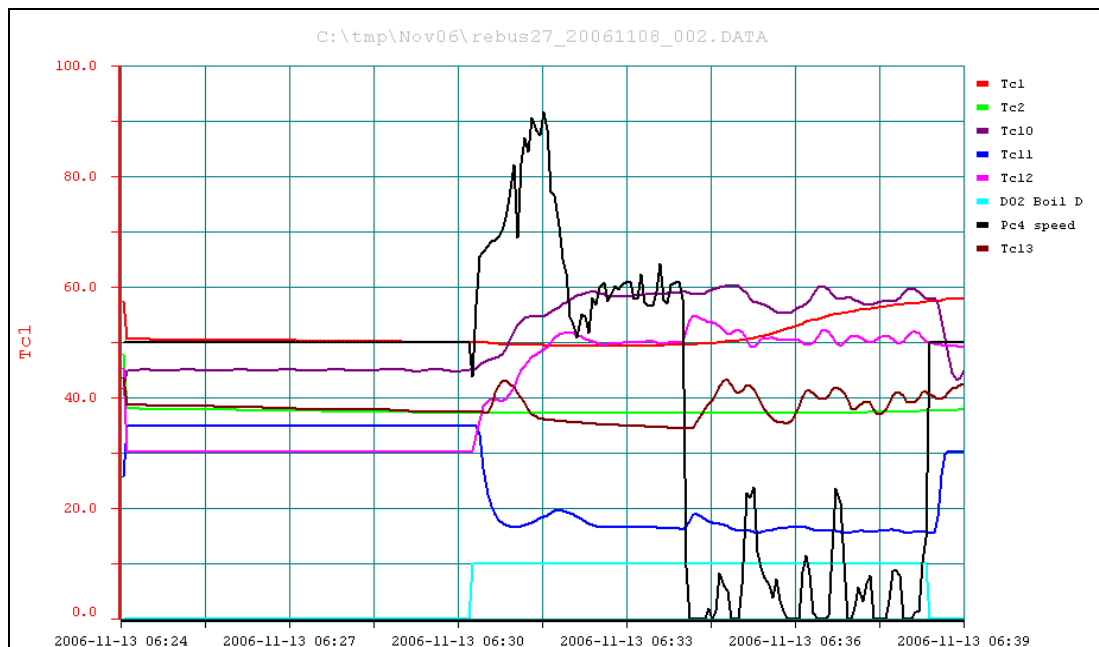

Fig. 5–23 Hot water preparation with boiler from start and after a short period a strong change to very low hot water tap flow rate with the final control algorithm to avoid overheating of hot water temperature (Tc12) (Tc1-Tc20 in °C / Pc4_speed in % / DO2_Boil_D is an on/off signal).

5.4 Boiler Condensation Rate in Practice

In order to get an overview on the realistic performance of the condensing natural gas boiler integrated in this solar combisystem, the amount of condensing water was measured during three different periods. The measurements were done during standard operation of the solar combisystem in the demonstration house. For each measurement period the condensing water was collected in a bottle and evaluated afterwards. The following three graphs (Fig. 5–24, Fig. 5–25 and Fig. 5–26) are showing the temperatures during the tests, measured by the temperature sensors of the controller. The boiler forward temperature is the sensor (Tc10), the boiler return temperature is (Tc13). The boiler is switched on when the signal (DO1_Boil_S) has the value 10.

The natural gas consumption was measured with the standard natural gas meter installed at the house and the low heating value of the natural gas, corrected for the measurement conditions was 10.67 kWh/m^3 (11.02 kWh/m_n^3). As a theoretical maximum condensation rate 1.6 Liter/kWh (Theiß 2001; Informationszentrum Energie 2000) was assumed. In Table 5–2 the main test conditions and the results of the three tests are shown.

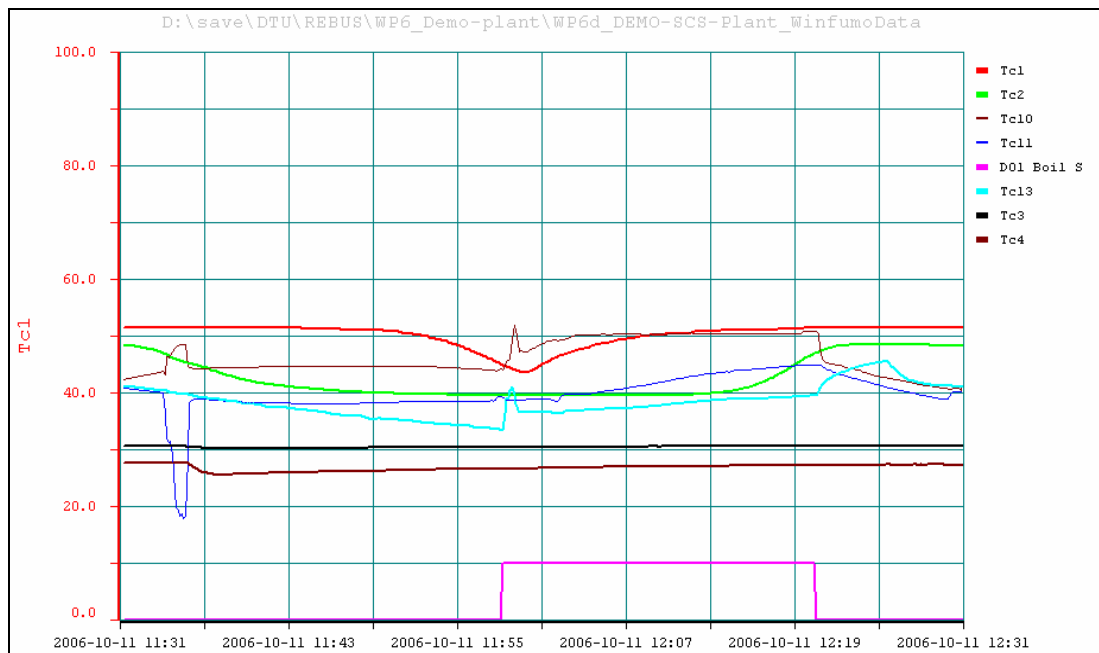

Fig. 5–24 Heating up the auxiliary volume with the condensing natural gas boiler with in average 52°C forward and 41°C return temperature resulting in 43% condensation rate (Tc1-Tc20 in $^\circ\text{C}$ / DO1_Boil_S is an on/off signal).

The major interesting result is that test 1 has a much higher condensation rate than test 3. This indicates that a very often published statement that condensation is mostly depending on the return temperature maybe is not the whole truth. Test 1 was in average performed with forward/return temperature of $52/41^\circ\text{C}$ and test 3 with $61/32^\circ\text{C}$. The return temperature of test 3 was much lower but the condensation rate as well: 28% compared to 43% in test 1. Obviously the forward temperature has a significant influence which also can be concluded when test 2 and test 3 are compared. Both tests were done with comparable return temperatures (29 and 32°C)

Laboratory Experiments

and average power (16 and 19 kW) but test 2 with a much lower forward temperature of 51°C has condensation rate of 46% compared to 28% in test 3. The difference of 64% higher condensation of test 2 is remarkable.

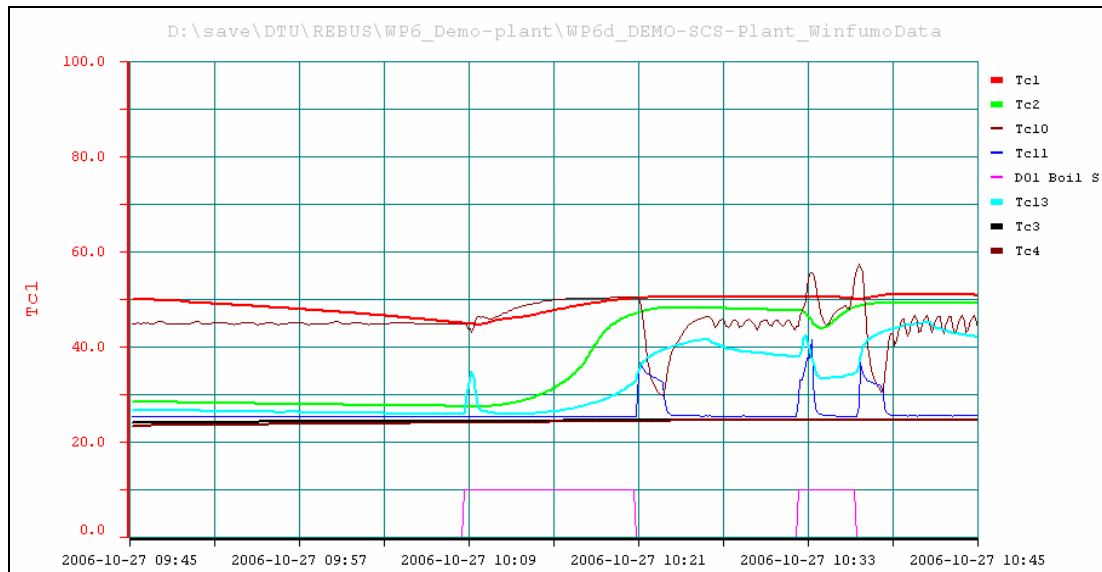

Fig. 5–25 Heating up the auxiliary volume with the condensing natural gas boiler with in average 51°C forward and 29°C return temperature resulting in 46% condensation rate (Tc1-Tc20 in °C / DO1_Boil_S is an on/off signal).

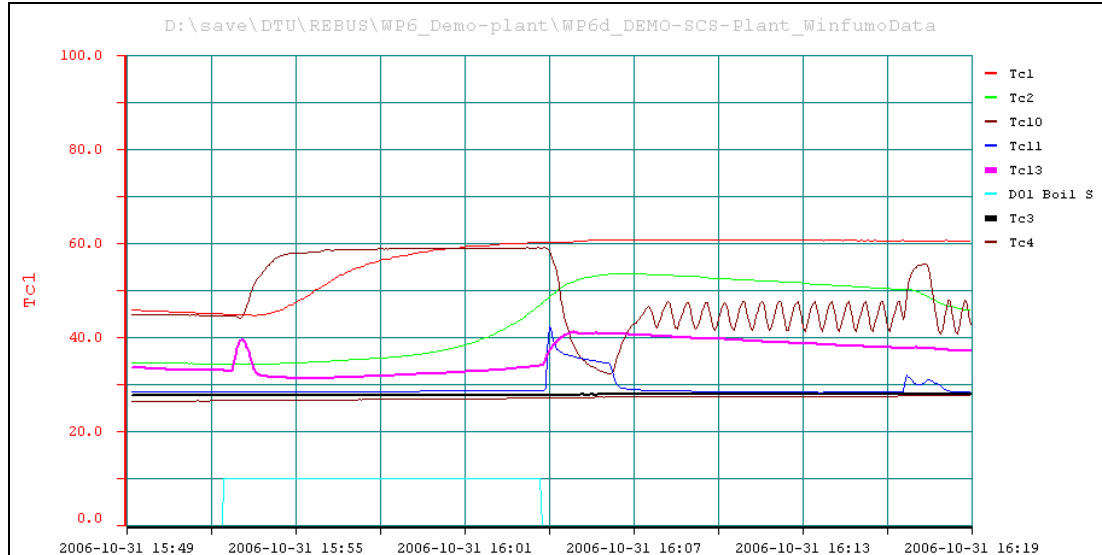

Fig. 5–26 Heating up the auxiliary volume with the condensing natural gas boiler with in average 61°C forward and 32°C return temperature resulting in 28% condensation rate (Tc1-Tc20 in °C / DO1_Boil_S is an on/off signal).

Unfortunately it was not possible to calculate the boiler efficiencies because the resolution of the energy meter is only 1 kWh, which is much too low for such short tests.

Table 5–2 Tests on condensation rate of the natural gas boiler in practice.

Test No:		1	2	3
Average forward temperature	[°C]	52	51	61
Average return temperature	[°C]	41	29	32
Average power, hydraulic	[kW]	8	16	19
Natural gas consumption	[m ³]	0.243	0.278	0.342
Natural gas consumption	[kWh]	2.593	2.966	3.649
Condensing water	[Liter]	0.179	0.218	0.164
Condensing water	[Liter/kWh]	0.069	0.073	0.045
Condensation rate	[%]	43	46	28

In Table 5–3 for comparison the test data are presented which are reported from the accredited test institute, the Danish Gas Technology Centre (Schweitzer 2004). If the results of Table 5–2 and Table 5–3 are compared, it has to be noted that the measurements in the test center were done under constant steady state operation conditions, where the measurements presented in Table 5–2 are relative strong influenced by start and stop effects due to the short test periods.

A comparison of test B and test C in Table 5–3 shows that with the same forward and return temperatures the boiler efficiency is quite different due to the different flow rate and power respectively. This indicates that the use of an auxiliary volume, as it is done in this solar combisystem, should have a positive effect on the boiler efficiency.

Table 5–3 Steady state tests on condensation rate of the natural gas boiler according to the test report from the Danish Gas Technology Centre (Schweitzer 2004).

Test No:		A	B	C	D
Forward temperature	[°C]	60	50	50	36.3
Return temperature	[°C]	40	30	30	30.1
Water flow rate	[Liter/h]	1030	236	1068	1086
Power out, hydraulic	[kW]	23.7	5.4	24.6	7.6
Natural gas consumption	[kW]	23.5	5.4	23.8	7.1
Boiler efficiency	[%]	101.4	100.4	104.0	107.8
Condensing water	[Liter/h]	1	0.3	1.9	0.8
Condensing water	[Liter/kWh]	0.043	0.056	0.080	0.113
Condensation rate	[%]	27	35	50	70

From the condensation rate point of view test 2 in Table 5–2 therefore fits quite good to the test results of test C in Table 5–3. This is also true for test 3 and test A. where in test 3 the much lower return temperature and the slightly lower power seems not to benefit a lot comparing the condensation rate. This again gives the indication that it is important to be able to operate the condensing natural gas boiler with forward temperatures clear below 60°C and not only low return temperatures are important.

Based on these comparisons it can be assumed that the boiler integration into the heating system in this concept enables the condensing natural gas boiler to operate under very good operating conditions. Measurement results at the end of 2007 finally will show on a yearly basis how good this concept is performing.

6. Demonstration House

In parallel to developing and testing the first prototype of the solar combisystem in the laboratory, a one family house was found where the house owner was willing to get the second prototype installed. To be able to compare the natural gas consumption and the electricity consumption for operating the heating system of the house with the old existing heating system and the new solar combisystem, in August 2004 measurements started in this demonstration house. This first period of measurements took place until April 2006, therefore a period of 21 months could be evaluated based on measurements of the old heating system with a non condensing natural gas boiler. From June until July 2006 the new solar combisystem was installed and then again measurements were started.

6.1 Description of the Demonstration House

The demonstration house is situated in the small town Helsingør, about 40 km north of Copenhagen (56°01' N, 012°12' E) and two adults and one teenager occupy it. The house shown in Fig. 6–1 has three floors: the basement with an entrance room, a bedroom, a bathroom and the technical room, the first floor with kitchen, living room and dining room and the second floor with two bedrooms and a bathroom. The house is about 9 m in length (east-west) and 7 m in width. Therefore, the gross area in the basement and the first floor is about 63 m² and in the second floor 46 m², in total about 172 m².



Fig. 6–1 View on the demonstration house from the south

Demonstration House

The space heating distribution system mainly consists of several old cast iron radiators (Fig. 6–2, left). The bedroom in the basement has floor heating with an extra pump with integrated mixing valve which is controlled by a room temperature sensor. The floor heating loops, each with a return temperature control thermostat valve, are in the entrance room and in the bathroom in the basement as well as in the bathroom in the second floor.



Fig. 6–2 Cast iron radiator in the dining room (left), the pump with integrated mixing valve for the bedroom in the basement (middle) and the return flow control thermostat valve for the floor heating in the bathroom in the basement (right).

The following three sketches (Fig. 6–3, Fig. 6–4 and Fig. 6–5) show the layout of the three floors, but not true to scale. The following abbreviations are used in these sketches:

- R – Radiator: white = in use; black = not used
- GB – Gas boiler
- FH – Floor heating
- DHW – Domestic Hot Water tank
- P3 – Pump of floor heating in the bedroom in basement

Demonstration House

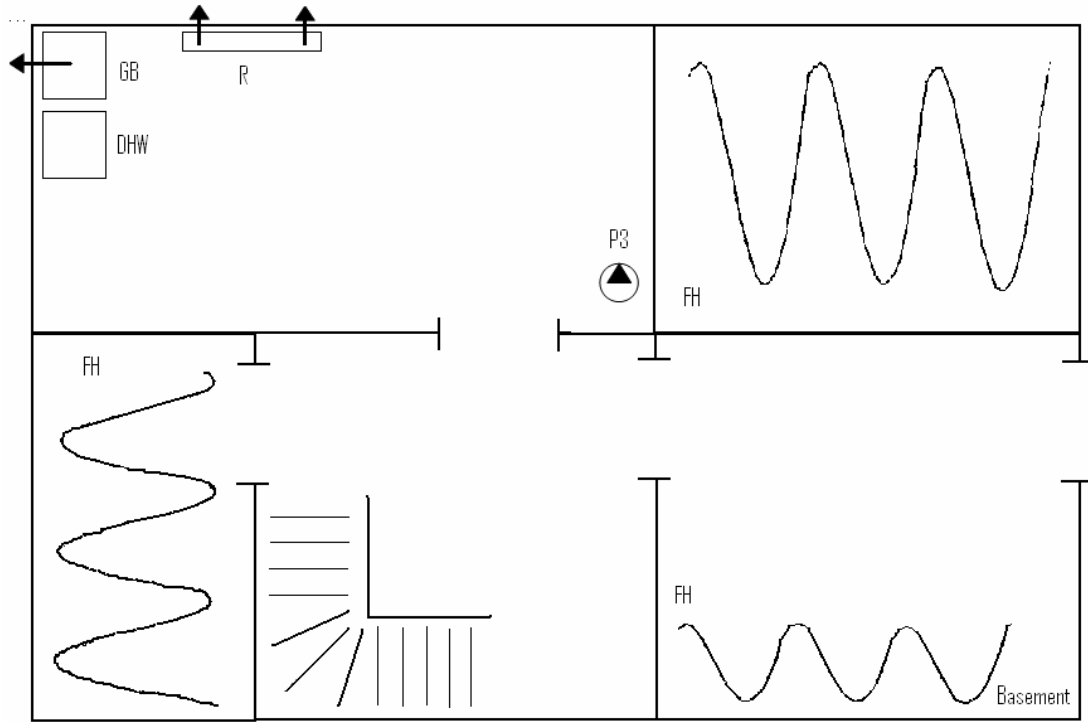

Fig. 6-3 Basement of the demonstration house (source: Carlqvist A.).

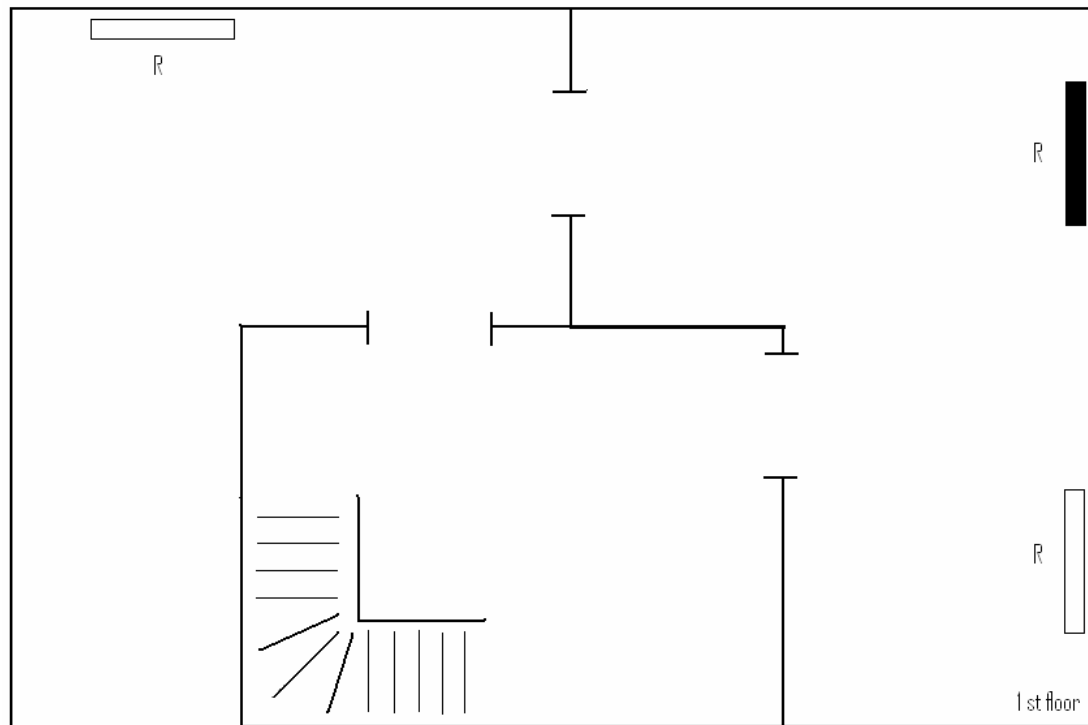

Fig. 6-4 First floor of the demonstration house (source: Carlqvist A.).

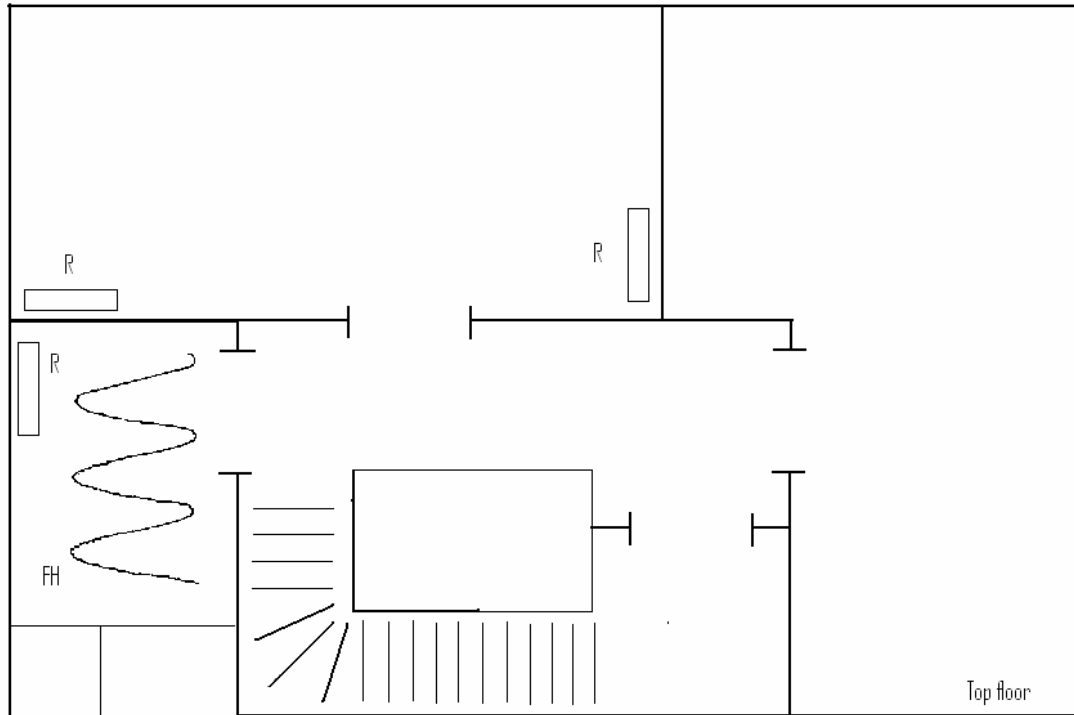

Fig. 6–5 Second floor of the demonstration house (source: Carlqvist A.).

6.1.1 The Old Natural Gas Heating System

The old heating system was supplied with heat by a non condensing natural gas boiler. For domestic hot water preparation the natural gas boiler heated a hot water tank (see Fig. 6–6).

- Natural Gas Boiler: Vaillant, Nominal Power: 22 kW; Construction year: 1990
- Domestic hot water tank volume: 50 Liter
- Number of pumps: 3; The main pump was integrated in the gas boiler, one extra pump for the floor heating in the bedroom in the basement and one hot water circulation pump.

The hydraulic scheme for the old heating system is shown in Fig. 6–7. In the house in total seven radiators are installed, all of them are equipped with a thermostat valve with an integrated room temperature sensor. The bedroom in the basement has floor heating with an extra pumped space heating circuit where the room temperature is controlled by a room temperature sensor which is controlling the mixing valve. Further, three more floor heating loops are installed in the two bath rooms and in the entrance room in the basement. All three floor heating loops are equipped with a thermostat valve which is controlling the return temperature.

Demonstration House



Fig. 6–6 The non condensing natural gas boiler (right) and the hot water tank (left).

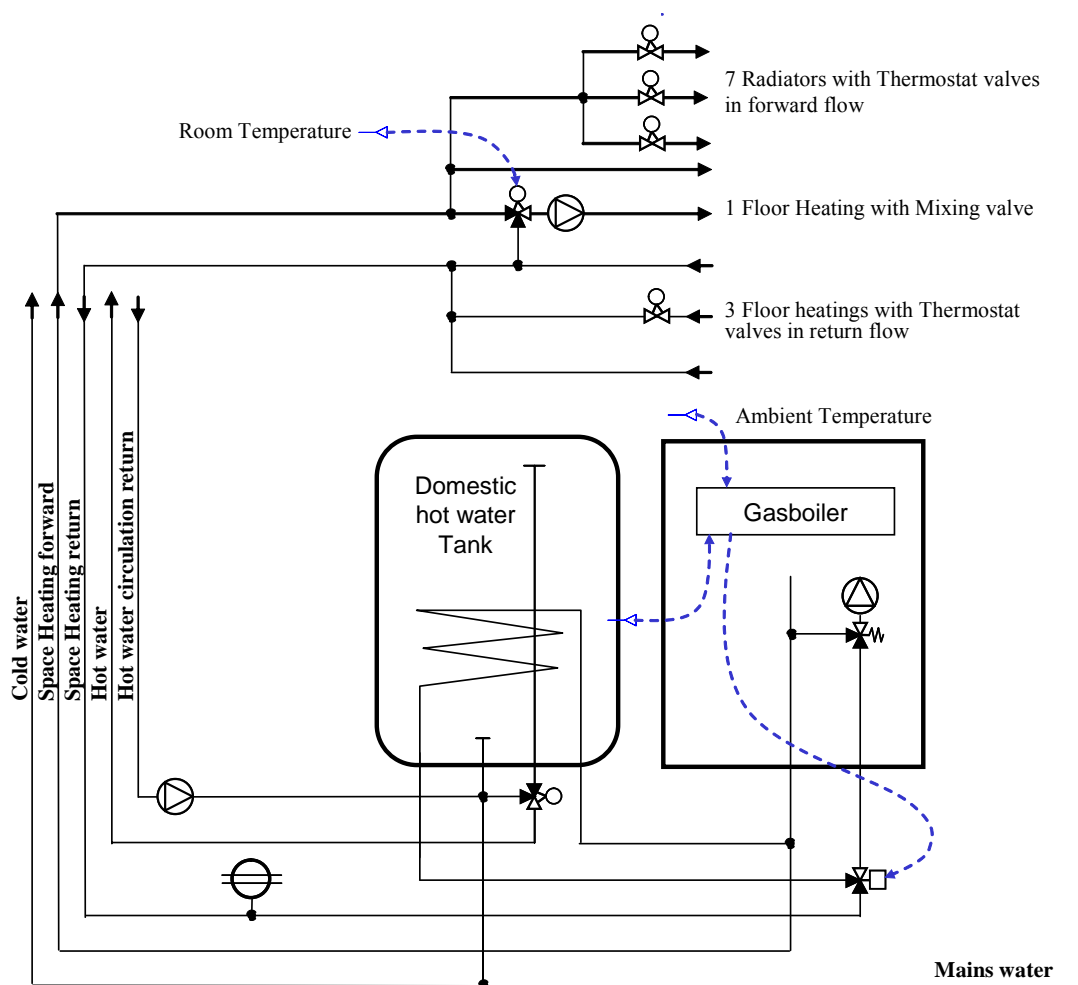

Fig. 6–7 Hydraulic scheme of the old heating system.

Demonstration House

In principle an ambient temperature sensor was connected to the controller of the boiler. But as described later in chapter 6.2, the controller did not work properly in space heating mode.

The hot water circulation pump was not connected to electric power for a long time. After setting the pump in operation on 21/11-2005 (daily from 06:00-10:00 and 17:00-20:00) and getting the experience that the energy losses are huge, the house owner decided to switch it off again on 20/12-2005 (see also chapter 6.2).

6.1.2 The New Installed Solar Combisystem

In June and July 2006 the new solar combisystem was installed. In Fig. 6–8 the demonstration house with five VELUX S08 collectors with a collector area of 6.75 m² in total (8 m² gross collector area) on the roof and the two 60 x 60 cabinets with a 360 liter solar tank installed in the basement are shown.



Fig. 6–8 Demonstration house with the collectors mounted on the roof (left) and the installed solar tank unit and the technical unit in the basement (right).

General main data:

Geographic position of the house: 56°01' N and, 012°12' E

Tilt angle of the roof: 45°

Azimuth of the roof: 15° East (from South)

Collector: VELUX, 5 pieces of type: S08 (D2178)

Technical data of one collector according to the VELUX data sheet (5/9-2006):

Net weight:	37 kg
Gross area:	1.6 m ²
Net area:	1.35 m ²
Absorber area:	1.36 m ²
Liquid content:	1.3 ltr
Proofed pressure:	10 bar
Max. pressure:	6 bar
Stagnation temperature:	196°C
Start efficiency:	0.79
First loss coefficient k_1 :	3.76 W/m ² K
Second loss coefficient k_2 :	0.0073 W/m ² K ²

(Based on net collector area)

Demonstration House

Incident angle modifier k_{θ} :	0.95 at 50° ($k_{\theta} = 1 - \tan^a(\theta/2)$; $a = 3.9$)
Heat capacity:	7.4 kJ/m ² K (2.06 Wh/m ² K)

Collector loop pipes:

Stainless steel flexible pipe	
Length forward pipe:	12 m
Length return pipe:	18 m
Inner diameter:	16.3 mm
Outer diameter:	21.8 mm
Insulation thickness:	13.0 mm
Heat conductivity:	0.04 W/mK
Liquid content:	0.14 ltr/m

Solar tank:

Produced by Metro Therm A/S	
Nominal volume:	360 liter
Dimensions of cabinet:	595 x 600 x 1820 mm
Insulation:	Polyurethane (PUR) foam and vacuum panel
PUR-foam, heat conductivity:	0.024 W/mK
Vacuum panel, heat conductivity:	0.005 W/mK

In order to have an as large as possible tank volume within a 60 x 60 cm cabinet a new tank was designed and produced as a prototype for this demonstration system. Standard tanks of Metro Therm A/S, which fit into a 60 x 60 cm cabinet, have a diameter of 500 mm. This prototype tank has a diameter of 550 mm and is again foamed into a 60 x 60 cm cabinet. Due to the 10% larger diameter the volume of the tank increased by about 20%. In order to keep the heat loss in the same range, on the four sides, where the insulation thickness would be only 25 mm, vacuum panels with a thickness of 20 mm were embedded into the foam. In chapter 3.2.2 the heat loss rate for this tank is investigated in detail. Based on these investigations a heat loss rate of about 2 W/K is expected for this prototype tank.

Condensing natural gas boiler:

Distributor:	Milton A/S
Type:	Milton Smart Line HR24
Nominal power, space heating:	5.7 – 23.0 kW
Nominal power, hot water:	5.7 – 28.5 kW

Test data according to the test certificate from Danish Gas Technology Centre (which is an accredited test laboratory in Denmark (Schweitzer 2004):

Boiler efficiency (36/30, 7 kW):	107.8 %
Boiler efficiency (50/30, 5 kW):	100.4 %
Boiler efficiency (50/30, 24 kW):	104.0 %
Boiler efficiency (60/40, 24 kW):	101.4 %

Calculated annual net efficiency for:

Domestic hot water:	2,000 kWh/a
Space heating:	20,000 kWh/a
	7.5 kW at -10°C ambient temperature

Demonstration House

Traditional space heating system: $T_{\text{forward}} = 76.5^{\circ}\text{C}$; $T_{\text{return}} = 57.9^{\circ}\text{C}$ at -10°C

Low temperature space heating system: $T_{\text{forward}} = 60.0^{\circ}\text{C}$; $T_{\text{return}} = 46.1^{\circ}\text{C}$ at -10°C

Yearly net efficiency, traditional: 96.4 %

Yearly net efficiency, low temperature: 98.4 %

Controller:

Producer: Lodam A/S

Type: LMC200

Free programmable microprocessor controller

4 pieces are connected via RS485 bus system

Main data for one LMC200:

Temperature sensor: 4, NTC-sensor

Digital Input: 4

Analog Input: 1

Potential free relay, 230V: 7

Analog Output, 0-10V: 2

In Fig. 6–9 the prototype controller for the demonstration system is shown. A master controller (on the left) and three slaves are connected via a RS485 Bus.

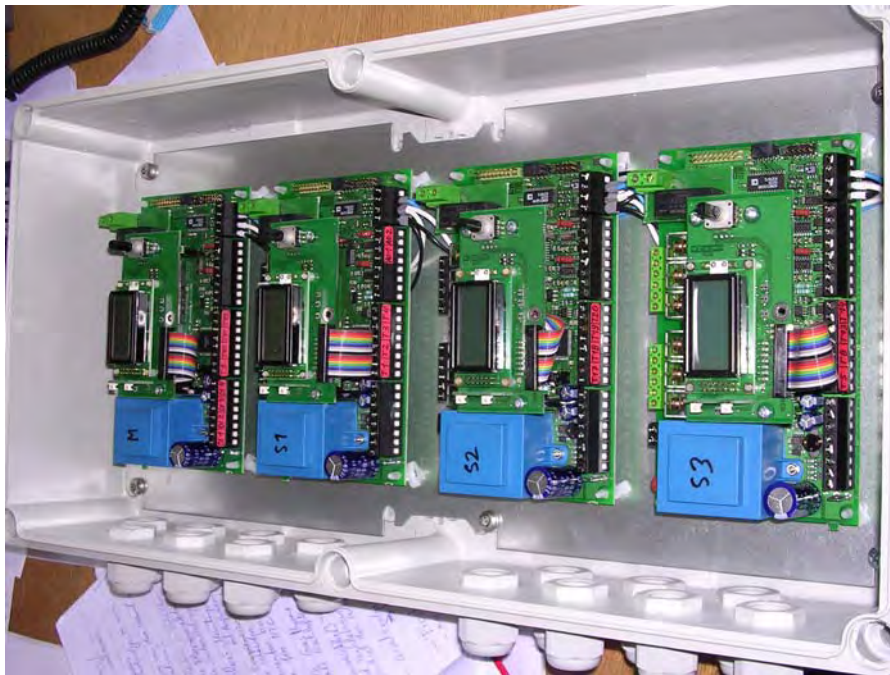

Fig. 6–9 Prototype controller; 4 LMC200 connected via RS485 Bus

In Fig. 6–10 the hydraulic design is shown in detail. The hydraulic concept is exact like presented before in Fig. 3–1. In this figure now the arrangement of the components and pipes fit as good as possible to the reality (see Fig. 6–11). Further, all additional components (like expansion vessel, filter, etc.) are shown, which are installed to ensure a reliable operation of the system.

Demonstration House

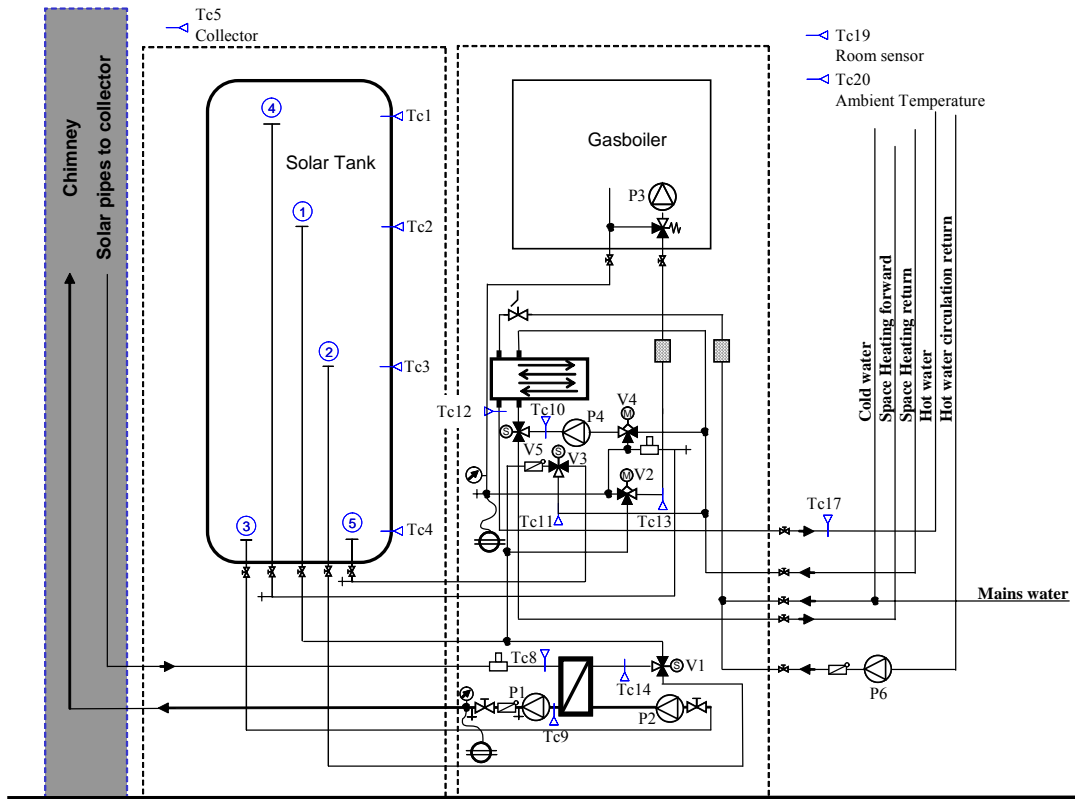

Fig. 6–10 Hydraulic scheme of the solar combisystem in the demonstration house.



Fig. 6–11 Hydraulic unit inside the technical cabinet in the demonstration system; the big black box is the insulated domestic hot water heat exchanger, below the main pump P4 can be seen.

The installation of the demonstration system finally looks as shown in Fig. 6–12. On the wall left of the solar tank the prototype controller is mounted, further left the black

box is the frequency converter for speed controlling the pump P4. Above the frequency converter the main electric supply box is mounted, which includes the electric meter to measure the so-called “parasitic” electricity to run the heating system.



Fig. 6–12 Installation after set in operation on 22/6-2006 (left) and after closing the cabinets with the cover plates (right).

6.2 Measurements of the Old Heating System

To show an overview on the typical natural gas consumption the house owner was asked for the yearly natural gas consumption in the last years. For the following accounting periods the natural gas consumption and the heating degree days were:

6/5-2001 till 5/5-2002:	2,524 m ³	2973 Kd
5/5-2002 till 28/4-2003:	2,693 m ³	3243 Kd
28/4-2003 till 10/5-2004:	2,927 m ³	3090 Kd
1/1-2005 till 31/12-2005:	2,355 m ³	3097 Kd

Heating degree days are calculated by daily summing up the difference of 17 minus the ambient temperature. This is done for all days if the daily average ambient temperature is lower than 17°C.

During the measurement period of the old heating system the floor heating circuits in the basement of the house were not set in operation because the basement was not occupied at that time. The basement in fact was heated by the heat losses from the natural gas boiler, the hot water tank and all the not insulated pipes in the technical room.

Until 21/12-2004 the natural gas boiler was operating in a very bad way due to an unexplainable problem of the internal controller and faulty installation of the ambient temperature sensor mounted outside at the house wall.

For domestic hot water preparation the boiler set temperature was constant at about 85°C. Even if there was no heat demand, the pump was on all the time and circulating water to the hot water tank heat exchanger. Much worse was the fact that also the ventilator of the combustion air was also running all the time, even when the burner

was switched off due to exceeding the maximum temperature. Therefore, the standby losses were extremely high especially in summertime.

In addition, the space heating controller was not able to operate in a proper way because (as found later when installing the new system) the ambient temperature sensor was mounted that faulty, that there was no electrical contact. Therefore, the controller could not measure the ambient temperature and as a logical consequence, it was not possible to heat the space heating forward flow depending on the ambient temperature according to the chosen “heating curve”.

Due to this faulty installation of the ambient temperature sensor the natural gas boiler was only able to use an internal fail case strategy which obviously was to heat the forward temperature to about 8-10 K higher temperature than the return flow temperature. Detailed investigations on this detail, e.g. by asking Vaillant, were not done.

6.2.1 Description of the Measurement Concept

In order to get the heat balance of the complete house, the following measurement concept (see Fig. 6–13) was designed and installed.

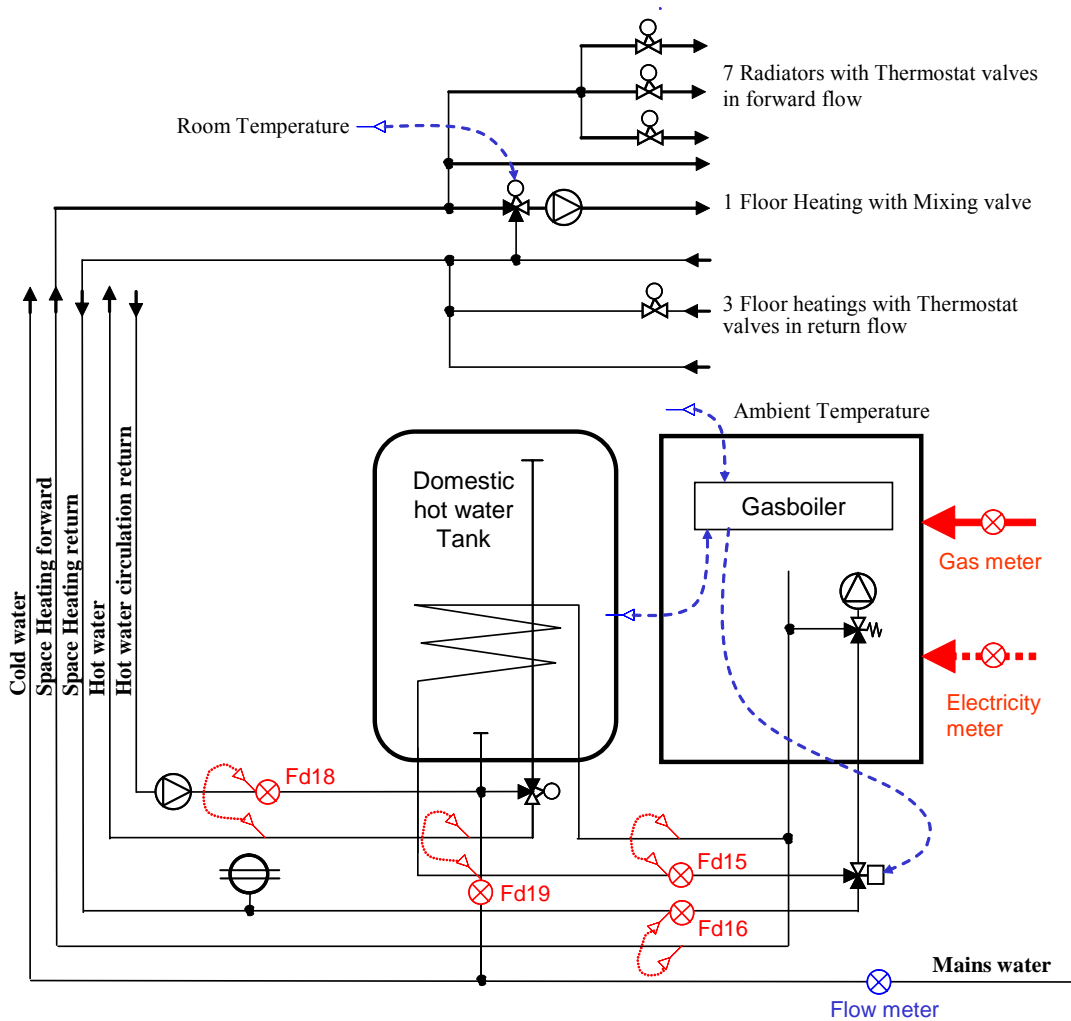

Fig. 6–13 Hydraulic scheme and measurement concept for the old heating system.

Demonstration House

In total four energy meters, one natural gas meter and one electricity meter were used:

1. Fd15: "Domestic Hot Water-Heating"
Energy meter for measuring the heat that is produced by the boiler and used for heating the hot water tank.
2. Fd16: "Space Heating"
Energy meter for measuring the heat that is produced by the boiler and used for space heating.
3. Fd18: "Domestic Hot Water-Circulation"
Energy meter for measuring the domestic hot water circulation heat losses.
4. Fd19: "Domestic Hot Water-Consumption"
Energy meter for measuring the domestic hot water consumption.
5. Gas meter: "Natural Gas Consumption"
Measuring the natural gas consumption that is used by the non condensing natural gas boiler.
6. Electric meter: "Electricity"
Measuring the electricity consumption to run the heating system: This is the boiler itself including the internal circulation pump and the controller plus the floor heating circulation pump and the domestic hot water circulation pump.

All these meters were equipped with pulse outputs for specified quantities of energy or volume per pulse, which were connected to a datalogger. Additional to the temperature sensors of the energy meters, thermocouples were mounted at the same positions and connected to the datalogger as well. All these data were collected and saved in the memory of the datalogger in periods of five minutes.

The datalogger was a DATATAKER DT50 (Datataker).

The four energy meters were from the former Danish company CLORIUS:

Type: CLORIUS Combimeter 3 EPD in combination with PT100 temperature sensors

According to the data sheet the accuracy of this type of energy meter is:

±4%: if: $Q > 0.3 \text{ m}^3/\text{h}$ and: temperature difference $> 20 \text{ K}$

±6%: if: $Q < 0.3 \text{ m}^3/\text{h}$ and: temperature difference $> 20 \text{ K}$

±6%: if: $Q > 0.3 \text{ m}^3/\text{h}$ and: temperature difference $< 10 \text{ K}$

±8%: if: $Q < 0.3 \text{ m}^3/\text{h}$ and: temperature difference $< 10 \text{ K}$

±5%: if: $Q > 0.3 \text{ m}^3/\text{h}$ and: $10 \text{ K} < \text{temperature difference} < 20 \text{ K}$

±7%: if: $Q < 0.3 \text{ m}^3/\text{h}$ and: $10 \text{ K} < \text{temperature difference} < 20 \text{ K}$

Since the energy meters were quite old they had to be calibrated. Calibration was done relative against each other but not against a calibrated normal because such a normal was not available at that time. The calibration was done two times for the following conditions:

Flow rate: $0.4 \text{ m}^3/\text{h}$ Temperature: $32^\circ\text{C} / 15^\circ\text{C}$ Power: 8 kW

Flow rate: $0.5 \text{ m}^3/\text{h}$ Temperature: $50^\circ\text{C} / 16^\circ\text{C}$ Power: 20 kW

The result of the calibration was that all four energy meters measured within the range of $\pm 2\%$ of the average in both tests. It was assumed that therefore also the absolute value of the measurements should be clear within the accuracy stated in the data sheet.

Demonstration House

The gas meter was a standard gas meter from the natural gas utility. It was an IGA, type: AC-5M. This gas meter was temperature calibrated to a reference temperature of 15.6°C. According to the information from the natural gas utility HNG (HNG 2006) the pressure of the natural gas typically is constant 22 mbar above ambient pressure. The accuracy of this gas meter according to the data sheet was:

$$\begin{aligned} \pm 2\%: & \text{ if: } Q > 0.05 \text{ m}^3/\text{h} \\ \pm 3\%: & \text{ if: } 0.025 < Q < 0.05 \text{ m}^3/\text{h} \end{aligned}$$

The electricity meter was from the Danish company TEE A/S: LK Type Wh3163, Class 2, therefore the accuracy of this electricity meter is $\pm 2\%$.

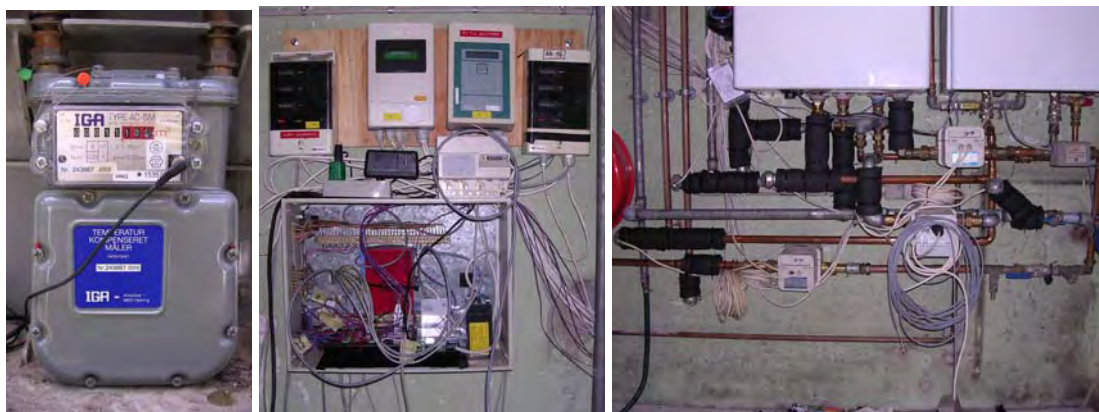

Fig. 6-14 Measurement equipment for the old heating system: left picture shows the gas meter, the middle picture shows the box with the datalogger DT50 and the electricity meter and the electronic modules of the energy meters above and the right picture shows the flow meters and the temperature sensors below the boiler and the hot water tank.

6.2.2 Energy Balance of the Old Heating System

In the demonstration house the old heating system based on a non condensing natural gas boiler was measured for a period of 21 months from August 2004 till April 2006. The monthly energy balance for this system is presented in Fig. 6-15 and Table 6-1. The definitions of the energy values and how they are measured are described in chapter 6.2.1 and Fig. 6-13. First of all, two points need to be explained in order to understand the graphs and tables:

- Conversion of measured cubic meter natural gas to energy:

To convert the natural gas consumption from volume to energy, the following heating value was used:

$$\text{Low heating value: } 10.67 \text{ kWh/m}^3 \quad (= 11.02 \text{ kWh/m}_n^3)$$

This is the average value of 42 measurement points in Denmark for the twelve months from April 2005 until March 2006. The maximum difference over these 12 months and all 42 measurement points was $\pm 0.5\%$ of this chosen value. Due to this very small variation, it was decided to use one constant value for the complete evaluation in the old heating system.

It has to be noted, that all graphs and tables are based on the low heating value of the natural gas.

- The efficiencies which are presented are defined as (see Fig. 6–13, page 105):

1. Boiler Efficiency:

$$\eta_{\text{boil}} = \frac{\text{Domestic Hot Water Heating} + \text{Space Heating}}{\text{Natural Gas Consumption}} \quad \text{Eq. 6-1}$$

2. Natural Gas - COP:

$$\text{COP} = \frac{\text{Domestic Hot Water Consumption} + \text{Space Heating}}{\text{Natural Gas Consumption}} \quad \text{Eq. 6-2}$$

3. Domestic Hot Water Efficiency:

$$\eta_{\text{DHW}} = \frac{\text{Domestic Hot Water Consumption}}{\text{Domestic Hot Water Heating}} \quad \text{Eq. 6-3}$$

4. Hydraulic Efficiency:

$$\eta_{\text{hyd}} = \frac{\text{Domestic Hot Water Consumption} + \text{Space Heating}}{\text{Domestic Hot Water Heating} + \text{Space Heating}} \quad \text{Eq. 6-4}$$

“Boiler Efficiency” is the average efficiency of the boiler over a period and therefore including start/stop losses and standby losses.

“Natural Gas - COP” is the coefficient of performance based on the natural gas consumption that is calculated with the low heating value.

“Domestic Hot Water Efficiency” is not including the boiler efficiency, therefore it is an efficiency taking into account the heat losses of the hot water tank, the pipes between the hot water tank and the boiler and the hot water circulation losses. Calculating the COP_{DHW} only for hot water preparation is only possible for months when no space heating energy is measured:

$$\text{COP}_{\text{DHW}} = \eta_{\text{DHW}} * \eta_{\text{boil}} = \frac{\text{Domestic Hot Water Consumption}}{\text{Natural Gas Consumption}} \quad \text{Eq. 6-5}$$

If this equation is used for months including space heating energy, it is important to have in mind that the boiler efficiency is an average value for the whole month and therefore strongly influenced by the boiler efficiency during space heating, which typically is much higher than the boiler efficiency during hot water preparation.

“Hydraulic Efficiency” is showing the overall system efficiency excluding the boiler efficiency. This key figure mainly will be used later to compare the new system with the old system without the influence of the different boilers.

As described in chapter 6.2, until 21/12-2004 the controller of the boiler was faulty and therefore the system was operating very inefficient. This can be observed in Fig. 6–15 especially from August until December 2004, where all three efficiencies are dramatically low. Also the energy demand for “Domestic Hot Water-Heating” is abnormal high compared to “Domestic Hot Water-Consumption” (about 2.5 times

higher). After the boiler was repaired on 21/12-2004, the results are much better. On 21/12-2004 the three main problems were solved:

1. The internal heat exchanger was exchanged because the old one was leaking.
2. The controller was repaired in such a way that if the burner was switched off, also the internal pump and the combustion air ventilator was switched off.
3. The controller also was repaired in such a way that during space heating the forward temperature was not the same as for hot water preparation, which was 85°C.

Due to the fact that the ambient temperature sensor had no contact to the controller, the space heating forward temperature still was not controlled according to the set heating curve. The effect of this will be explained later in chapter 6.2.3.

The summer months July and August 2005 show the very typical decrease of the efficiencies if (almost) only hot water preparation demand has to be supplied.

On 21/11-2005 the hot water circulation pump was set in operation by the electrician. The pump was controlled by a clock and was in operation daily from 06:00 to 10:00 and 17:00 to 20:00. On 20/12-2005 the house owner decided to switch off the hot water circulation pump because of the huge heat losses. As the numbers in Table 6–1 show, the heat losses of 297 kWh during 30 days are in same order as the hot water consumption. In other words, the hot water circulation losses were about 100% of the hot water consumption, and this just based on 7 operating hours per day. The reasons for this high circulation loss are explained in the next chapter more detailed.

Looking on the tendency of “Domestic Hot Water Efficiency” from January 2005 until April 2006 it can be observed that this efficiency is decreasing from around 80% to less than 70%. This tendency fits to the also occurring changes of the hot water consumption in the same period. In the first three months in 2005 the consumption in average was about 11 kWh/day compared to about 9 kWh/day in the first three months in 2006. Further, due to any reasons also the temperature difference of the hot water consumption increased by about 5 K (from around 56 to 61°C). Since the cold water temperature evolution typically is very similar from year to year it can be assumed that the set point temperature of the hot water tank was higher. In December 2005 again (after December 2004) the internal heat exchanger of the natural gas boiler had to be replaced due to leakage and maybe at that time something changed the setting. This of course is leading to higher standby losses of the hot water tank and the pipes between the boiler and the hot water tank. Since the hot water mixing valve at hot water tank outlet did not operate properly (see later in Fig. 6–17: hot water temperature up to 70°C) the heat loss effect of hot water staying in the pipe after a tapping is increased also quite strong.

Therefore this is assumed to be the explanation for the quite strong reduced “Domestic Hot Water Efficiency” within this period.

In the months May, June and September, October 2005 the boiler efficiency is about 5 per cent points higher than in the core heating period. This is most likely due to the lower temperature level of the space heating system and the higher combustion air temperature during this period which both is reducing the exhaust gas losses. Again most likely this is also influenced by the fact that the ambient temperature sensor was not connected to the boiler controller.

Demonstration House

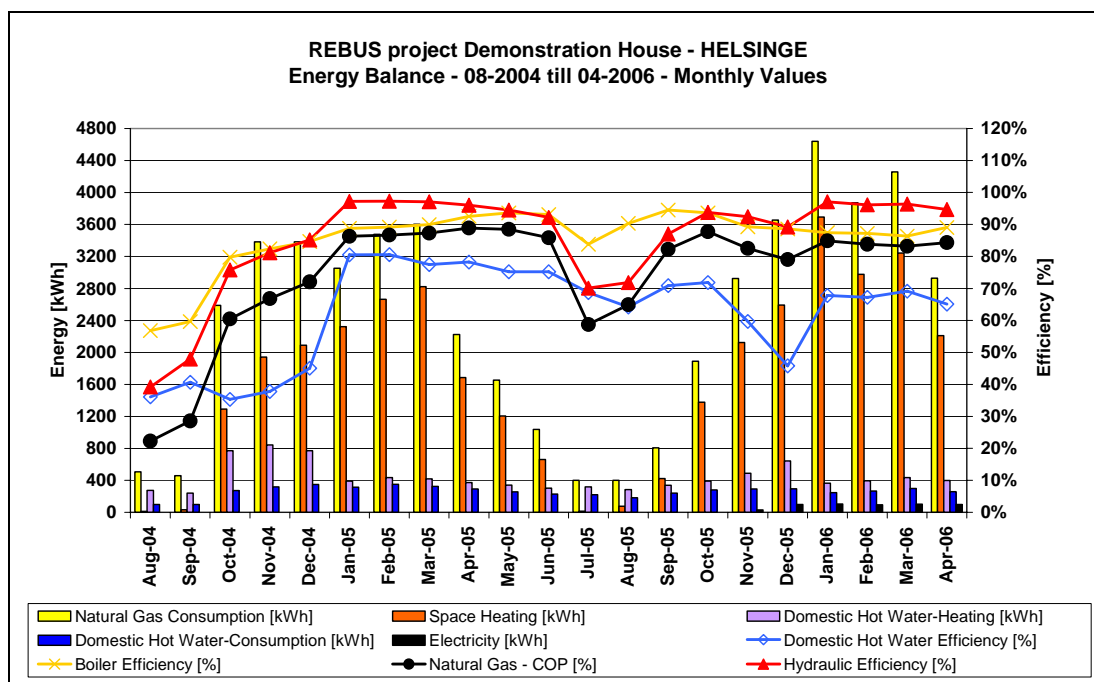

Fig. 6–15 Energy balance for the old heating system in the demonstration house.

Table 6–1 Energy data for the old heating system in the demonstration house

	Ambient Temperature Average	Natural Gas Consumption		Space Heating	Space Heating	Space Heating	Domestic Hot Water-Heating	Domestic Hot Water-Consumption	Domestic Hot Water-Consumption	Domestic Hot Water-Consumption	Domestic Hot Water-Circulation	Electricity	Boiler Efficiency	Domestic Hot Water Efficiency	Natural Gas - COP	Hydraulic Efficiency
	[°C]	Gas [kWh]	SH [kWh]	[m ³]	[K]	[kWh]	[kWh]	[kWh/d]	[K]	[kWh]	[kWh]	[kWh]	eta_boil [%]	[%]	[%]	[%]
08-2004	17.7	507	14	1.1	10.9	274	99	3.2	58.1	0	-	56.8%	36.1%	22.3%	39.2%	
09-2004	13.5	460	33	1.7	17.0	241	98	3.3	60.3	0	-	59.6%	40.7%	28.6%	47.9%	
10-2004	9.4	2588	1292	30.7	36.3	773	273	8.8	60.3	0	-	79.8%	35.3%	60.5%	75.8%	
11-2004	4.7	3382	1943	43.8	38.2	844	319	10.6	62.5	0	-	82.4%	37.8%	66.9%	81.2%	
12-2004	3.3	3382	2090	120.6	14.9	773	348	11.2	60.5	0	-	84.6%	45.0%	72.1%	85.2%	
01-2005	2.6	3055	2322	243.8	8.2	391	315	10.2	55.8	0	-	88.8%	80.5%	86.3%	97.2%	
02-2005	-0.3	3477	2665	223.8	10.3	434	350	12.5	57.1	0	-	89.1%	80.6%	86.7%	97.3%	
03-2005	0.9	3602	2822	234.0	10.4	418	324	10.5	57.0	0	-	89.9%	77.5%	87.3%	97.1%	
04-2005	7.8	2224	1685	218.8	6.6	373	292	9.7	54.6	0	-	92.5%	78.3%	88.9%	96.1%	
05-2005	11.0	1655	1207	182.1	5.7	342	257	8.3	52.6	0	-	93.6%	75.2%	88.5%	94.5%	
06-2005	14.1	1038	663	90.2	6.3	304	229	7.6	50.6	0	-	93.1%	75.2%	85.9%	92.2%	
07-2005	17.2	400	15	0.9	13.8	320	220	7.1	48.1	0	-	83.8%	68.7%	58.8%	70.1%	
08-2005	15.2	401	77	16.5	4.0	285	183	5.9	30.3	0	-	90.4%	64.2%	64.9%	71.8%	
09-2005	13.9	808	424	105.9	3.4	340	241	8.0	54.5	0	-	94.5%	70.9%	82.3%	87.0%	
10-2005	10.3	1890	1378	227.1	5.2	391	281	9.1	57.0	0	-	93.6%	71.8%	87.8%	93.8%	
11-2005	5.2	2926	2124	258.0	7.1	489	292	9.7	59.2	91	31	89.3%	59.7%	82.6%	92.5%	
12-2005	1.9	3654	2593	218.5	10.2	644	295	9.5	59.4	206	98	88.6%	45.8%	79.0%	89.2%	
2005		25131	17974	2019.6	7.7	4733	3279	9.0	52.8	-	-	90.4%	69.3%	84.6%	93.6%	
01-2006	-1.6	4639	3693	283.2	11.2	364	247	8.0	59.6	0	106	87.4%	67.8%	84.9%	97.1%	
02-2006	-0.2	3871	2978	255.0	10.1	397	267	9.5	61.9	0	94	87.2%	67.2%	83.8%	96.1%	
03-2006	-1.1	4257	3243	258.7	10.8	434	300	9.7	62.6	0	104	86.4%	69.1%	83.2%	96.4%	
04-2006	5.9	2928	2210	273.2	7.0	398	259	8.6	61.5	0	98	89.1%	65.1%	84.3%	94.7%	

6.2.3 Specific Detailed Evaluation of the Old Heating System

Based on some graphs taken from the quite big amount of measured data, some main characteristics of the old heating system are discussed in the following part. First of all in Fig. 6–16 the behavior of the old heating system is shown in its worst manner before the big repair on 21/12-2004. It should be mentioned that according to the house owners this way of operation has been the standard for many years. Even when it was reported to the maintenance technician that it seems something is wrong with the heating system, nothing was found.

First it can be observed that the inlet- and outlet temperatures of the hot water heat exchanger (“Domestic Hot Water – Forward” and the “Domestic Hot Water – Return” temperature) most of the time are at the same temperature level of about 85°C. Also the flow rate “Domestic Hot Water – heating” is always very high: 500 to 750 liter/h. This clearly shows that hot water heating is on all the time and therefore pipe losses and boiler losses are high because of this constant high temperature level of the system. An additional effect which cannot be seen in the figure is the fact that also the ventilator for the combustion air was running all the time, even if the burner of the boiler was off. Of course this caused also huge stand by losses of the boiler.

The “Space Heating – Forward” temperature also has always this high temperature level of 85°C. The “Space Heating – Return” temperature corresponds quite well with the flow rate “Space Heating”. Each time when obviously a radiator valve was opened, the space heating return temperature drops to about the room temperature for a while before it is rising again.

Getting a stable comfort temperature in the house with such a heating system obviously is not possible. It was also reported by the inhabitants that it was always too hot or too cold. Furthermore the inhabitants did not use the thermostat valves correctly. They used them more or less as on and off valves turning always from totally open to totally closed and backwards.

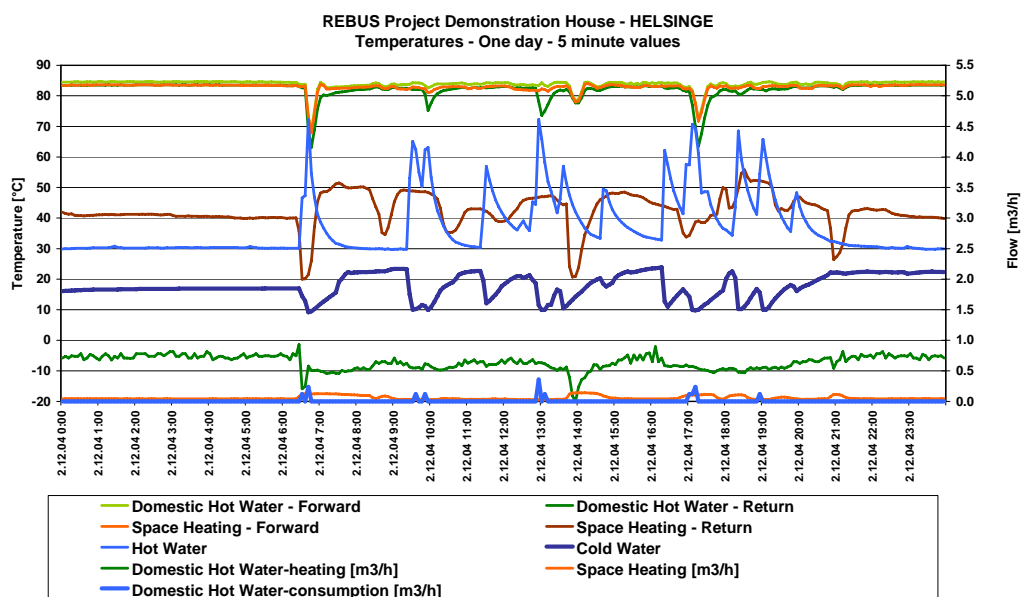

Fig. 6–16 Behavior of the old heating system before the repair on 21/12-2004

In Fig. 6–17 the old heating system behavior after the repair is shown. Now the system is switching between the two different operating modes of hot water preparation and space heating.

When heating the hot water tank, the temperature “Domestic Hot Water – Forward” still reaches about 85°C and the temperature “Domestic Hot Water – Return” is about 10 K lower and the flow rate “Domestic Hot Water – heating” reaches about 0.75 m³/h. This is a very typical situation in such conventional heating systems, which do not allow a condensing natural gas boiler to operate with the benefit of condensing since the return temperature is much higher than the dew point of about 57°C. With a flow rate of 0.75 m³/h and a temperature difference of 10 K the power can be calculated to about 9 kW. Since the gas boiler is able to produce much more power, it is clear that the heat exchanger is designed too small.

The question arises why natural gas boilers are designed, built and sold, which have a peak power for hot water preparation up to 30 kW, if they never can deliver this power.

Of course in this system the hot water set temperature is about 70°C, which is very high. But even if the set temperature for hot water would be 60°C (what is typical to avoid legionella problems in the hot water tank), it would be necessary to have a forward temperature of at least 15 K more, therefore 75°C. Since the temperature difference will be about the same, the return temperature can be expected to be around 65°C, still much too high for condensing.

Further, on it can be observed that almost after each hot water tapping, the boiler starts to heat the hot water tank. This also can be observed in most conventional heating systems. The reason is that only one temperature sensor in combination with a hysteresis is used to switch on and off the boiler. Therefore the often mentioned argument that a hot water tank is avoiding many starts and stops, in reality is not true for most of the heating systems.

Looking on the behavior of the system during space heating now a much lower “Space Heating – Forward” temperature can be observed. Due to the fact that the ambient temperature sensor had no electrical contact to the boiler controller, the boiler could not control the forward temperature depending on the ambient temperature according to the heating curve. Obviously the boiler controller had an internal fail case strategy heating the forward temperature to about 8 K more than the return temperature. In Fig. 6–17 it can be seen that depending on the flow rate “Space Heating” the “Space Heating – Return” temperature was reacting and the “Space Heating – Forward” temperature is following with a more or less constant temperature difference.

Demonstration House

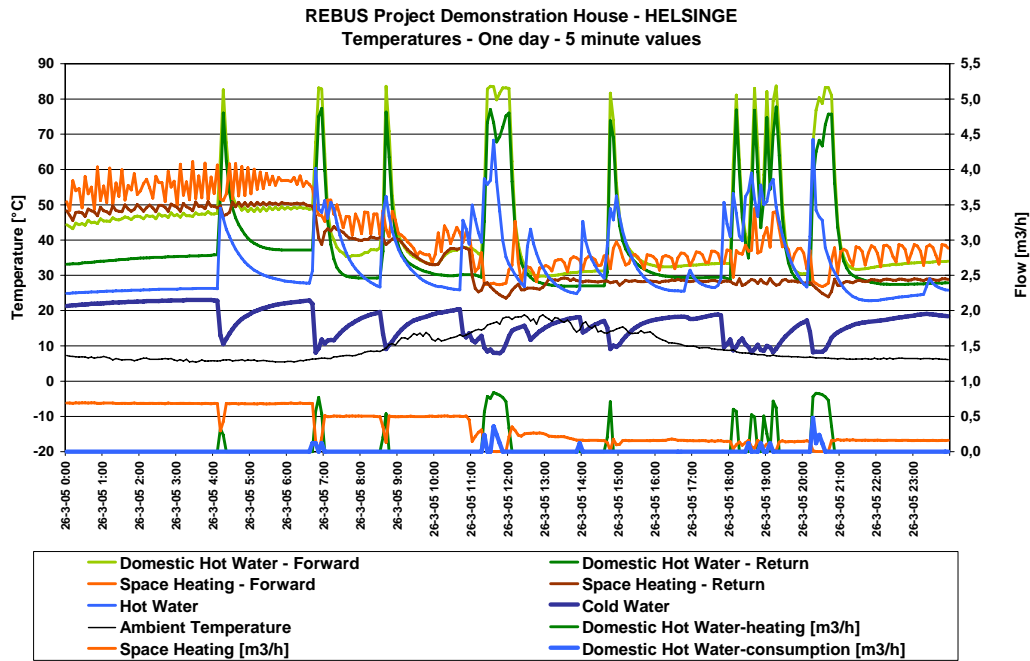

Fig. 6–17 Behavior of the old heating system after the repair on 21/12-2004

In Fig. 6–18 a day during the one month period with active hot water circulation pump is shown. Based on the devolution of the “Water Circulation Return” temperature it can be observed that the circulation pump is switched on at 06:00. and 17:00 when the temperature is increasing with a step upwards. The circulation pump stops at 10:00 and 20:00 respectively. Therefore, the total running time per day is 7 hours. This is the case for all seven days a week.

Looking on the energy “Circulation Losses” and the high “Water Circulation Return” and “Hot Water” temperature during the periods when the circulation pump is switched off, it can be observed that due to thermal driven buoyancy effects still a quite high flow rate occurs. The reason for that is a not working non return valve.

The effect of this mistake can also be observed during hot water tapping. For example at 1 p.m. during a hot water tapping the circulation return temperature drops down to less than 20°C. This only can happen if cold water flows backwards through the circulation return pipe and this is only possible if there is no non return valve. Of course this results also in much lower tap temperature because high temperature from the normal hot water pipe is mixed with cold water from the circulation pipe. This effect also has been reported from the inhabitants.

Due to the high circulation heat losses of course the hot water tank must be heated in very short intervals, which is leading to these strong fluctuations especially of the “Domestic Hot Water-Forward” temperature.

Demonstration House

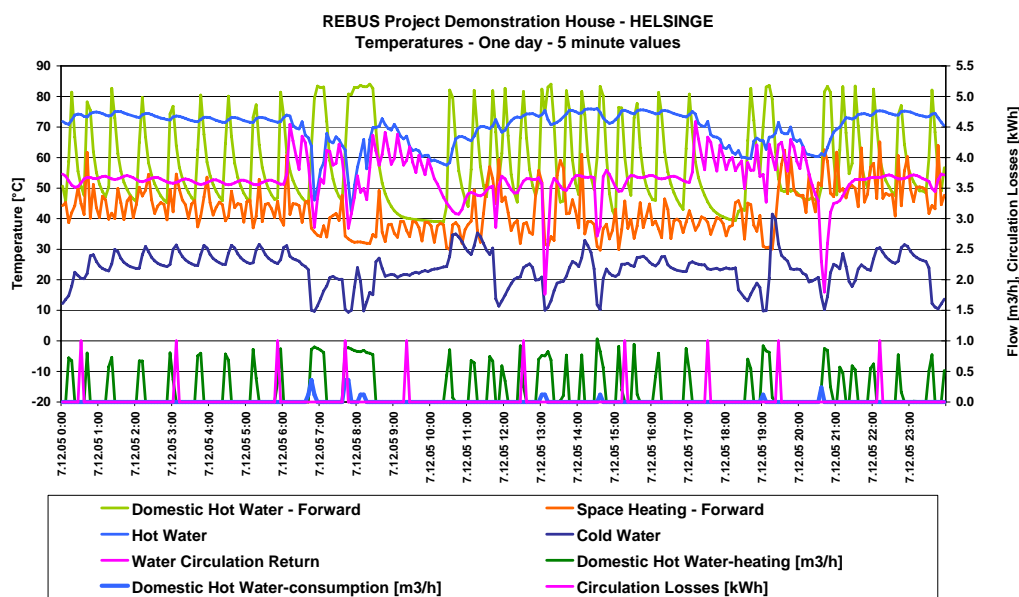

Fig. 6–18 Behavior of the old heating system when the hot water circulation pump was activated.

6.3 Measurements of the New Solar Combisystem

In June 2006 the new solar combisystem was installed and the technical unit was set in operation on 20/6-2006. On 6/7-2006 the collector loop was filled and set in operation as well. Unfortunately, the old energy meters, which were used again, after reinstallation, did not operate properly anymore. Therefore, it was necessary to order new energy meters. Due to holiday period the delivery time was incredibly long, the new energy meters were finally installed on 7/9-2006.

During the summer period 20/6 until 7/9-2006 only the gas meter, the electricity meter and one of the old, but reliable energy meters could be used.

The space heating forward temperature during this period was controlled by a heating curve depending on the ambient temperature with some special settings. The space heating forward temperature is 45°C at ambient temperatures higher than 10°C, 47°C at ambient temperature of 0°C and it is 60°C at ambient temperatures less than minus 10°C (see Fig. 6–19). The main reasons for this setting are:

1. The space heating loop shall be operated as good as possible as a low flow system to ensure low return temperatures. Especially in autumn and spring, it is important to have a low temperature level in the solar tank to maximise the potential of gaining solar energy from the solar collector loop. In combination with correctly used and adjusted thermostat valves at the radiators the flow rates of each radiator are controlled automatically in such a way that a high temperature difference can be achieved.
2. In combination with other parameter settings in the controller, with this heating curve the condensing natural gas boiler is operating in the space heating mode with a forward temperature of about 52°C down to an ambient temperature of 0°C, which ensures good condensation and therefore high boiler efficiency. At ambient temperatures of less than 0°C the gas boiler is operating in the domestic hot water mode with a forward temperature of about

62°C, which is reducing the condensation rate significantly if the return temperature is not very low.

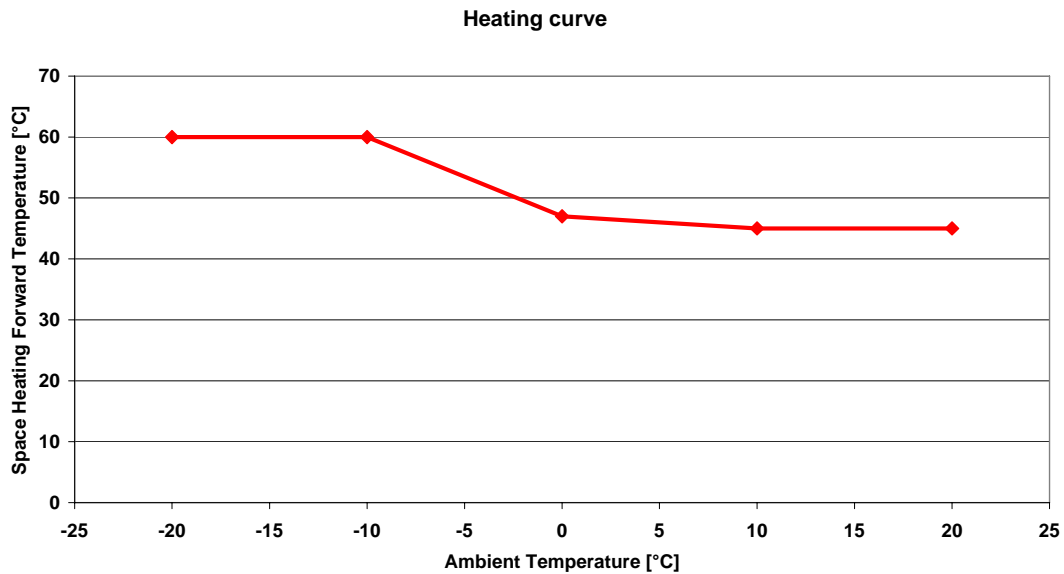

Fig. 6–19 Heating curve for the space heating forward temperature depending on the ambient temperature.

6.3.1 Description of the Measurement Concept

In order to get the heat balance of the complete house, in total five energy meters, one natural gas meter and one electricity meter were installed (see Fig. 6–20):

1. Fd1: “Solar Gain”
Energy meter for measuring the heat that is delivered from the solar collector and used for heating the solar tank. This heat value is the collector gain minus heat losses of the primary solar collector circuit and the solar heat exchanger.
2. Fd2: “Boiler”
Energy meter for measuring the heat that is produced by the boiler and delivered to the tank or directly used for space heating or hot water preparation.
3. Fd3: “Space Heating”
Energy meter for measuring the heat used for space heating.
4. Fd4: “Domestic Hot Water-Consumption”
Energy meter for measuring the domestic hot water consumption.
5. Fd5: “Domestic Hot Water-Circulation”
Energy meter for measuring the domestic hot water circulation heat losses.
6. Gas meter: “Natural Gas Consumption”
Measuring the natural gas consumption in [m³] that is used by the condensing natural gas boiler.
7. Electric meter: “Electricity”
Measuring the electricity consumption to run the solar combisystem: this is the boiler itself including the internal pump and the controller plus all three pumps and all five valves inside the technical unit, the floor heating circulation pump (not shown in Fig. 6–20) and the domestic hot water circulation pump.

Demonstration House

In Fig. 6–20 the hydraulic scheme including the energy meters is shown. All temperature sensors shown in this figure and named with “Tc...” are connected to the controller.

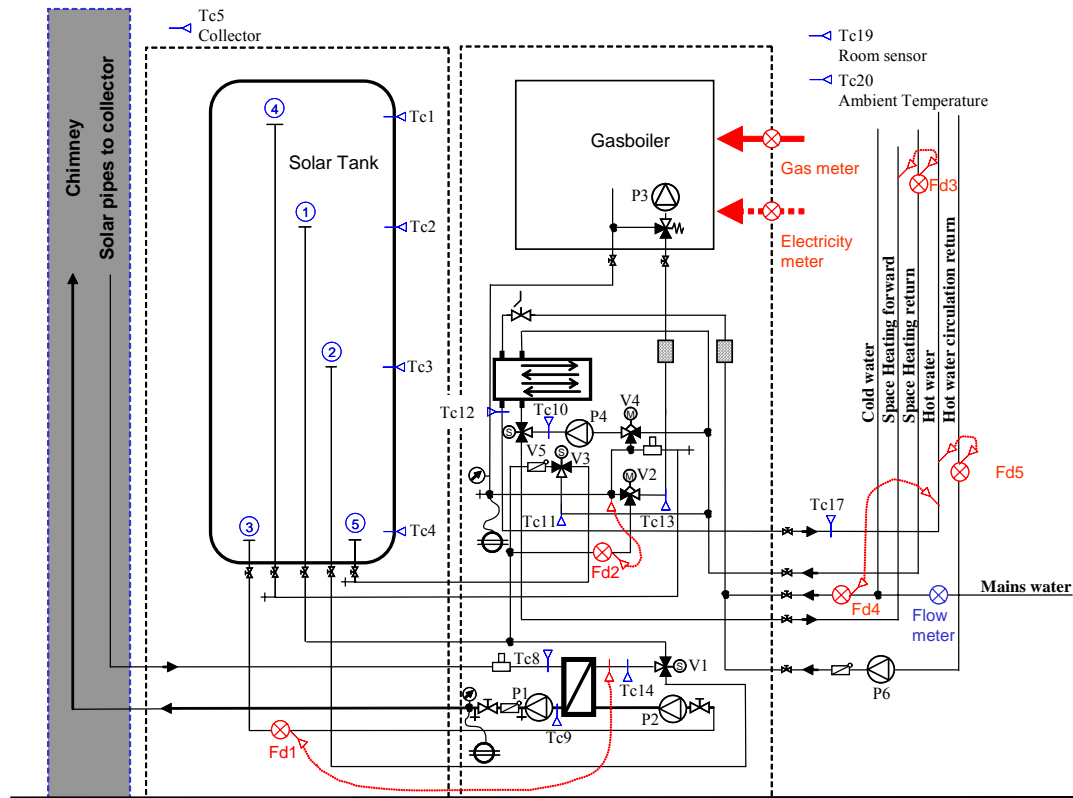

Fig. 6–20 Hydraulic scheme and measurement concept for the new solar combisystem in the demonstration house.

All meters were equipped with pulse outputs for specified quantities of energy or volume per pulse, which were connected to a datalogger. Additional to the temperature sensors of the energy meters, at the same positions thermocouples were mounted and connected to the datalogger as well. All these data were collected and saved in the memory of the datalogger in periods of three minutes.

The datalogger used, was a DATATAKER DT500 (Datataker).

The five energy meters used were from the company Brunata A/S:

Type: HGQ3-R0-184 /1/B/0/-/24/0% 2 pieces

Type: HGQ3-R2-184 /1/B/0/-/24/0% 3 pieces

Accuracy according to EN 1434: class 2 (which corresponds to an accuracy of 2%)

The gas meter was a standard gas meter from the natural gas utility. It was the same gas meter as used for the measurements of the old heating system. It was an IGA, type: AC-5M. This gas meter was temperature calibrated to a reference temperature of 15.6°C. According to the information from the natural gas utility (HNG 2006) the pressure of the natural gas typically is constant 22 mbar above ambient pressure. The accuracy of this gas meter according to the data sheet was:

±2%: if: $Q > 0.05 \text{ m}^3/\text{h}$

±3%: if: $0.025 < Q < 0.05 \text{ m}^3/\text{h}$

The electricity meter was from the Danish company TEE A/S: LK Type Wh3163, Class 2, therefore the accuracy of this electricity meter is $\pm 2\%$. It was the same electricity meter as used for the measurements of the old heating system.

The picture in Fig. 6–21 shows the measurement equipment mounted in the demonstration house.

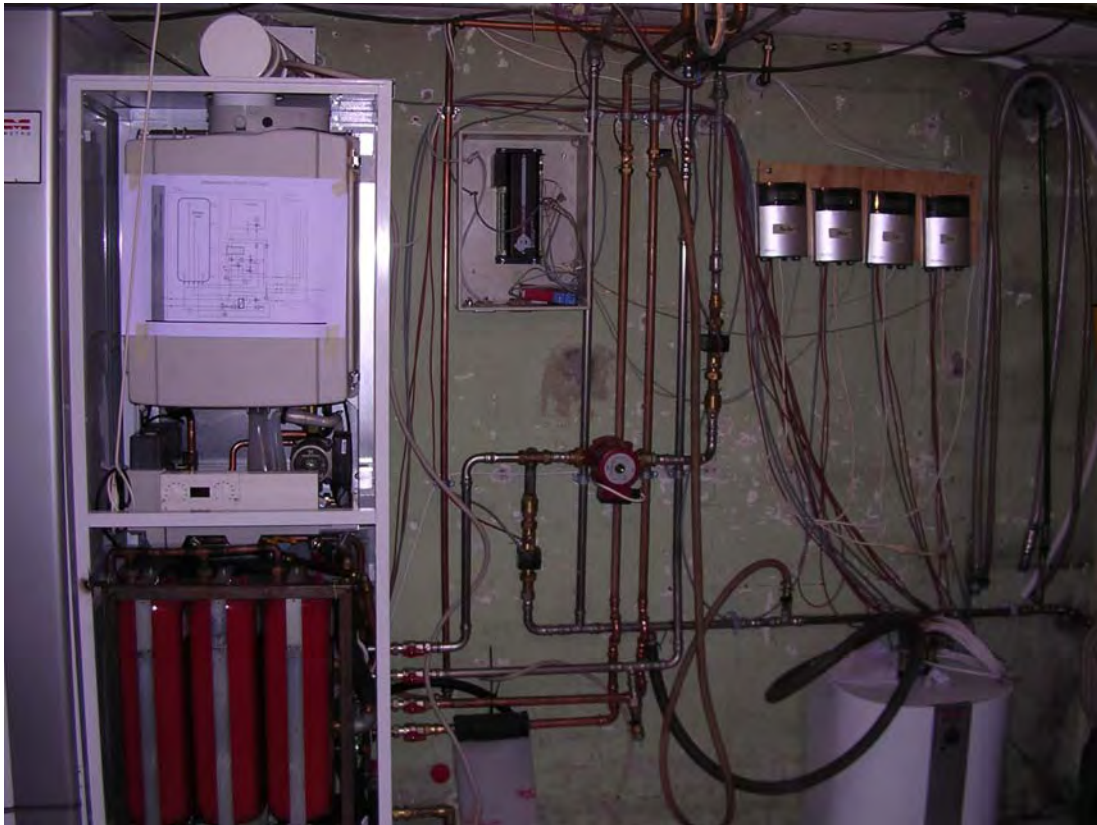

Fig. 6–21 Measurement equipment for the new solar combisystem; in the grey box is the datalogger DT500; on the right, four of the energy meters are mounted on the wall.

6.3.2 Energy Balance of the New Solar Combisystem

In the demonstration house the new solar heating system based on a condensing natural gas boiler was measured for a period of 4 months from October 2006 till January 2007. The monthly energy balance for this system is presented in Fig. 6–22 and Table 6–2. It is planned to collect the data further on till end of 2007 in order to get a full year. The definitions of the energy values and how they are measured are described in chapter 6.3.1 (page 115) and Fig. 6–20. The efficiencies are defined as:

1. Boiler Efficiency:

$$\eta_{\text{boil}} = \frac{\text{Boiler}}{\text{Natural Gas Consumption}} \quad \text{Eq. 6–6}$$

2. Solar Fraction:

$$SF = \frac{\text{Solar}}{\text{Solar} + \text{Boiler}} \quad \text{Eq. 6-7}$$

3. Natural Gas - COP:

$$COP = \frac{\text{Domestic Hot Water Consumption} + \text{Space Heating}}{\text{Natural Gas Consumption}} \quad \text{Eq. 6-8}$$

4. Hydraulic Efficiency:

$$\eta_{\text{hyd}} = \frac{\text{Domestic Hot Water Consumption} + \text{Space Heating}}{\text{Boiler} + \text{Solar}} \quad \text{Eq. 6-9}$$

“Boiler Efficiency” is the average efficiency of the boiler over a period and therefore including start/stop losses and standby losses.

“Solar Fraction” shows the share of energy delivered from the solar collector circuit compared to the total hydraulic energy supplied to the system. (Not the fuel consumption!) Therefore all heat losses have to be covered by the boiler and the solar collector in the same ratio as the solar fraction is calculated. As discussed in detail by (Heimrath 2004) with good arguments at least eight different types of solar fractions can be defined. The main problem is how to share the heat losses between the auxiliary heat source and the solar collector. Anyway, in order to evaluate a solar heating system the solar fraction itself is not sufficient. It is necessary to evaluate the whole system as well, which for example can be done with the following two key figures.

“Natural Gas - COP” is the coefficient of performance based on the natural gas consumption that is calculated with the low heating value. In the case of solar heating systems, the COP can be much greater than one, because of the gained solar energy. In summer time, typically the COP is infinite thanks to 100 % solar fraction (if parasitic electricity for pumps, etc. is not taken into account).

“Hydraulic Efficiency” shows how much of the energy delivered from boiler and solar collector was really consumed in the house. The remaining energy is heat loss.

The result of the few months is presented in Fig. 6-22 and Table 6-2. In the period from October until middle of December, the controller program was evaluated, tested and improved in several steps. In addition, the technical unit was improved as well. On the other hand, the climate and the user behavior are changing the boundary conditions daily. Therefore, several effects influence the key numbers in a positive or negative way and it is not possible to conclude exactly based on monthly values how much the changes in the system improved the system. In chapter 5 (page 69), based on shorter measurement periods these effects are discussed more detailed.

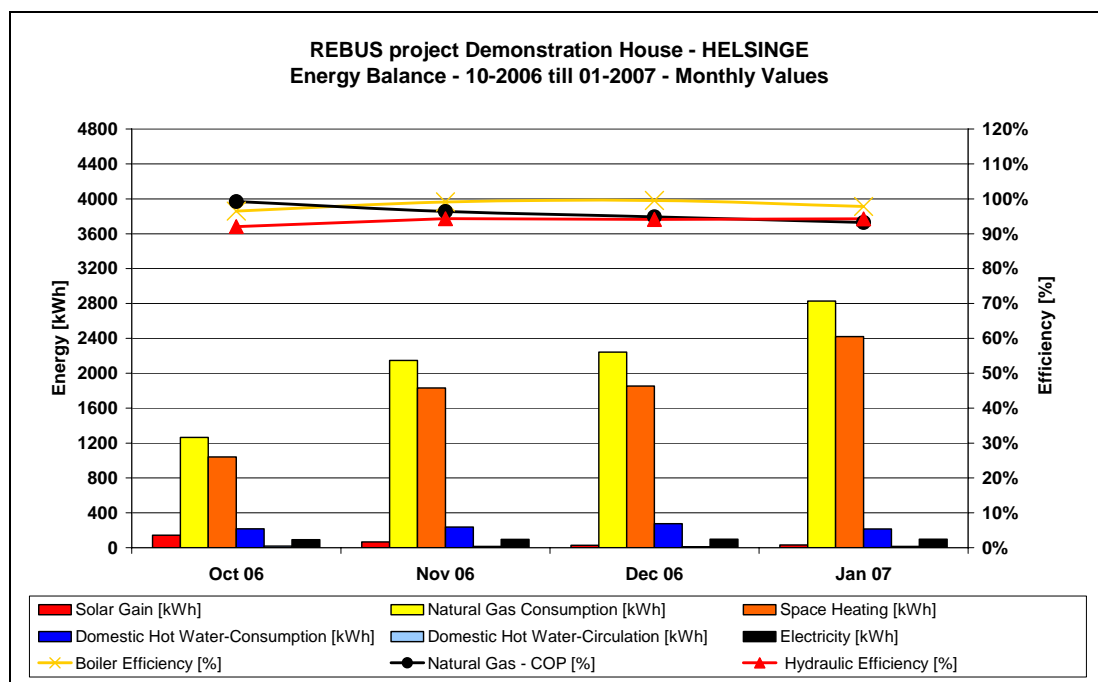

Fig. 6-22 Energy balance for the new solar heating system in the demonstration house.

Table 6-2 Energy data for the new solar heating system in the demonstration house

	Ambient Temperature Average Source: DMI		Natural Gas Consumption Low Heating Value = 10.67 kWh/m ³		Boiler		Boiler Temperature Difference Monthly average		Solar Gain		Space Heating		Space Heating Temperature Difference Monthly average		Domestic Hot Water-Consumption		Domestic Hot Water-Consumption Average daily consumption		Domestic Hot Water-Consumption Temperature Difference Monthly average		Domestic Hot Water-Circulation		Electricity consumption per day Solar Heating System		Boiler Efficiency (Boiler/Gas)		Natural Gas - COP (DHW+SH)/(Gas)		Solar Fraction (Solar+Boiler)		Hydraulic Efficiency (DHW+SH)/(Boiler+Solar) Circulation as Loss	
	Ta	Gas	Boiler	Boiler	Solar	SH	SH	DHW	DHW	DHW	DHW	DHW	DHW	DHW	DHW	DHW	DHW	DHW	DHW	DHW	DHW	DHW	DHW	DHW	DHW	DHW	DHW	DHW	DHW	DHW	DHW	
	[°C]	[kWh]	[kWh]	[K]	[kWh]	[kWh]	[K]	[kWh]	[kWh/d]	[K]	[kWh]	[kWh]	[kWh]	[kWh]	[kWh]	[kWh]	[kWh]	[kWh]	[kWh]	[kWh]	[kWh]	[kWh]	[kWh]	[kWh]	[kWh]	[kWh]	[kWh]	[kWh]	[kWh]	[kWh]		
10-2006	11.7	1266	1222	16.8	143	1040	11.9	216	7.0	35.3	18	2.9	96.5%	99.2%	10.5%	92.0%																
11-2006	7.4	2146	2127	15.6	66	1830	12.7	238	7.9	37.4	14	3.1	99.1%	96.4%	3.0%	94.3%																
12-2006	6.6	2244	2233	16.1	27	1853	12.5	274	8.8	39.2	10	3.2	99.5%	94.8%	1.2%	94.1%																
01-2007	4.3	2828	2766	15.9	30	2421	12.3	214	6.9	39.6	14	3.2	97.8%	93.2%	1.1%	94.2%																

In October the hydraulic efficiency (last column in Table 6-2) was 92 % while from November until January the hydraulic efficiency was quite constant at about 94.2 %. A reason for that most likely was one change which was done end of October: The cabinet of the technical unit was closed with the goal to reduce the heat losses of all non-insulated (except the heat exchangers) components inside the cabinet, which obviously was achieved.

Also the boiler efficiency in October was only 96.5 % where it was 99.1 and 99.5 % in November and December. A remarkable difference of the monthly natural gas consumption (1,266 kWh compared to around 2,200 kWh) is one typical reason for such a difference. The boiler efficiency typically is higher with higher load because of relative less heat losses due to less standby periods. On the other hand this effect is not very strong if the heat load is above 1,000 kWh, what can be observed clearly in several measurement reports (Furbo et.al. 2004; Wolff et.al. 2004). But two more reasons might influence this improvement. Due to the closed cabinet since end of

October of course also the standby losses of the boiler are reduced since the boiler is inside the cabinet. Additionally also since end of October the combustion air for the boiler is not sucked directly from outside but from inside the cabinet via the technical room and a hole in the wall. Due to this change the inlet temperature always is about 30 to 35°C instead of the ambient temperature. In fact this is a kind of heat recovery of the heat losses in the technical room and in the cabinet.

In January the boiler efficiency decreased a little to 97.8 % which is assumed to be due to the lower ambient temperature which forces the boiler to operate more often in the hot water mode (see 3.1.5, page 35) at the higher temperature level with a set point forward temperature of about 62°C instead of 52°C. Since the space heating temperature difference also in January was quite similar to the period before (around 12 K), necessarily also the space heating return temperature (following the forward temperature) was higher. This of course reduces the condensation rate quite strong (see 5.4, page 92) and therefore also the boiler efficiency.

In general it can be observed that the temperature difference of the boiler in all four months was around 16 K. Since the boiler always can charge the auxiliary volume in the solar tank, the boiler flow rate also is always quite constant: about 580 ltr/h. Therefore it can be calculated that the boiler also is operating always at a quite constant power of about 11 kW in average. The monthly average space heating power during these four months was between 1.4 and 3.3 kW. This shows that normally the boiler would be forced most of the time to operate far below the minimum power of 5.7 kW, which can be reached by modulation. Therefore a quite high frequency of start and stops of the burner would occur and decrease the boiler efficiency and increase the emissions.

The contribution of the solar collector during these four months naturally was not very high, especially since the solar heating system (6.75 m² collector area) is relative small for a solar combisystem. In October the solar fraction in total was 10.5 %. Looking at the system as an oversized solar domestic hot water system and considering also the hydraulic efficiency of the whole system, the solar collector supplied about 61 % of the hot water consumption.

The following 4 months February till May (which are not measured yet) typically are those with much higher irradiation and therefore also the solar fraction should be higher.

The overall efficiency is the coefficient of performance (COP), assuming that the complete solar combisystem is a heating system, which is consuming natural gas to supply the demand of domestic hot water and space heating. In fact this is the major interest: to use as less as possible auxiliary fuel to satisfy the demand. This key figure will be most interesting after a full period of one year measurements because of the very uneven contribution of solar energy within one year.

Anyway, a coefficient of performance of 93.2 % and 94.8 % (in January and December with almost no solar contribution) compared to a conventional heating system is a quite good result.

A Danish study (Furbo 2004) presented monthly measurement results of a heating system in a one-family house with a condensing natural gas boiler. The coefficient of performance for example was 94.1 % at 2298 kWh natural gas consumption in April or 95.3 % at 2706 kWh natural gas consumption in October. The monthly boiler efficiency in this two cases was 96.6 % in April and 96.3 % in October respectively.

6.3.3 Specific Detailed Evaluation of the New Solar Combisystem

In the following section based on data logged from the controller in the demonstration house some typical operating conditions are presented and discussed. The most important topic in this system is the domestic hot water preparation under all the different boundary conditions. Further, also the behavior during space heating will be discussed based on some graphs. The following list gives an overview of the following graphs:

- System behavior during summer time without space heating demand; thermal stratification in the solar tank and hot water preparation.
- System behavior during space heating period with effect of the auxiliary volume on the start/stop frequency of the natural gas boiler.
- Domestic hot water preparation during space heating season with different start and operating conditions.

In Fig. 6–23 a typical summer situation is shown. The solar tank is heated to about 65°C by the solar collector (Tc8) before the solar pump (Pc2) is switched off at about 16:30. After some hot water tapplings (DI1) in the evening the bottom of the tank (Tc4) has a temperature of about 32°C. During the night due to the internal heat transfer in the solar tank the bottom is heated to about 36°C, whereas the upper part of the tank is getting colder (Tc1-Tc3) due to heat losses and heat transfer to lower parts of the tank. In the morning, several hot water tapplings (DI1) take place and obviously only little sunshine enables the system to preheat the bottom part of the tank again.

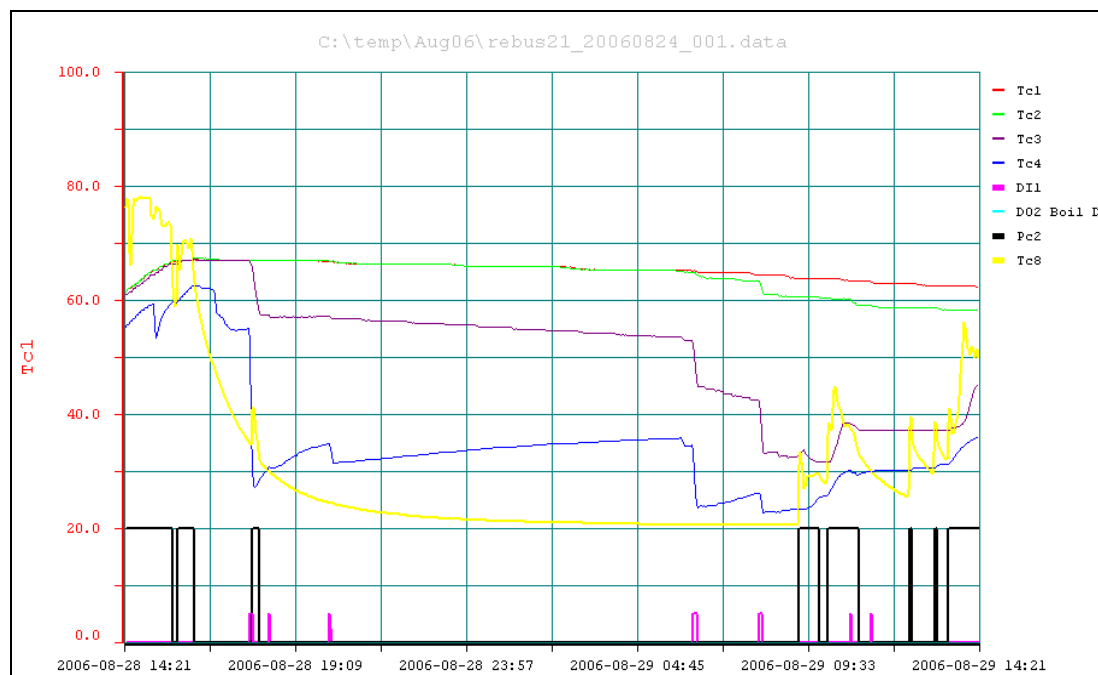

Fig. 6–23 Thermal stratification in the solar tank on a summer day with hot water preparation and without auxiliary heat demand (Tc1-Tc20 in °C / DI1, DO2_Boil_D and Pc2 are on/off signals).

In Fig. 6–24 a day is shown where due to sufficient high solar energy the solar tank reaches the maximum temperature of 90°C at about 14:00. At that time, the pump (Pc2) is switched off and the solar collector temperature (Tc5) very fast increases until stagnation temperature is reached. The stagnation temperature is more than

150°C, just the controller is not able to measure temperatures more than 150°C. As long as the solar collector temperature is more than the maximum temperature (in this case 100°C), the pumps (Pc1 and Pc2) are not allowed to run. As soon as the collector temperature decreases to less than 100°C the pumps start again at about 17:30. Since at that time the incident angle is very high, the collector is not able any more to produce heat at the desired temperature level of about 60°C.

After the hot water tapplings in the evening the bottom temperature (Tc4) during night increased by about 15 K from about 27 to 42°C due to internal heat transfer.

In the morning, the solar collector pumps (Pc2) in the beginning are running only for short intervals until the irradiation is powerful enough. During this time it can be observed that the temperature of sensor (Tc3) is strongly decreasing. This is due to some hot water tapping but also because the flow entering the tank via pipe 2 is much colder than the water in the tank. It can be observed that when (Tc8) is getting higher than (Tc3), of course (Tc3) is increasing again quite fast.

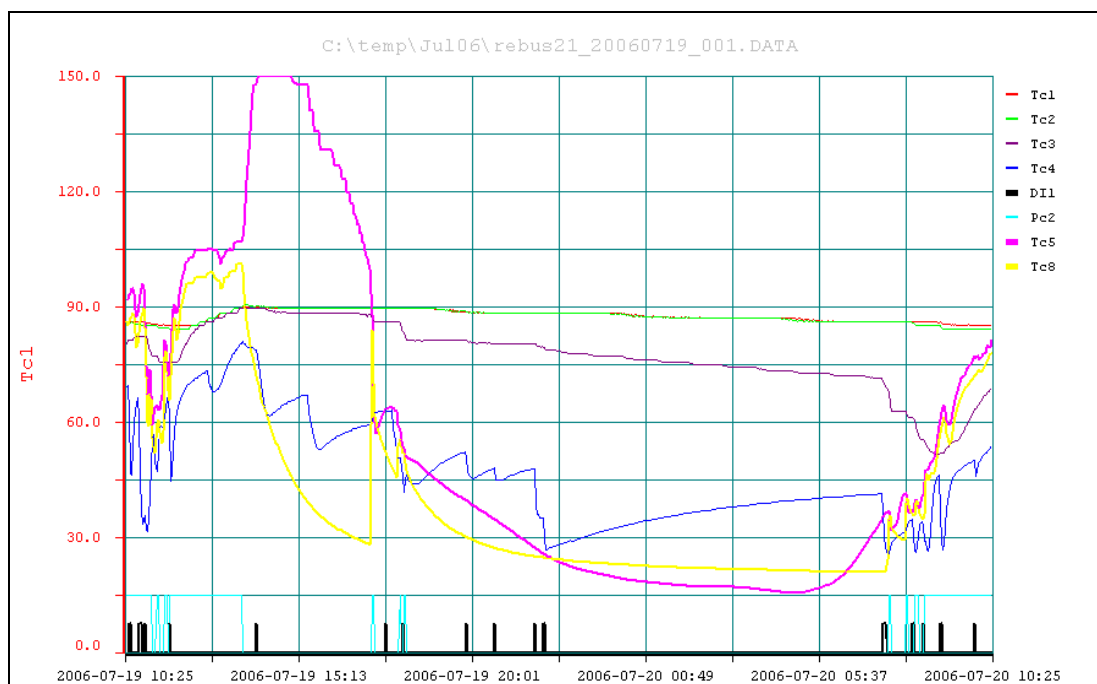

Fig. 6–24 Thermal stratification in the solar tank on a summer day with high irradiation which is leading to stagnation of the solar collector (Tc1-Tc20 in °C / DI1 and Pc2 are on/off signals).

In Fig. 6–25 a summer day is shown where the temperature at the top of the tank (Tc1) is not sufficiently high anymore for domestic hot water preparation. At about 06:00 in the morning in parallel to hot water tapping also the natural gas boiler is in operation. The lower part of the solar tank (Tc3 and Tc4) is cooled and the top part of the solar tank (Tc1 and Tc2) is heated at the same time.

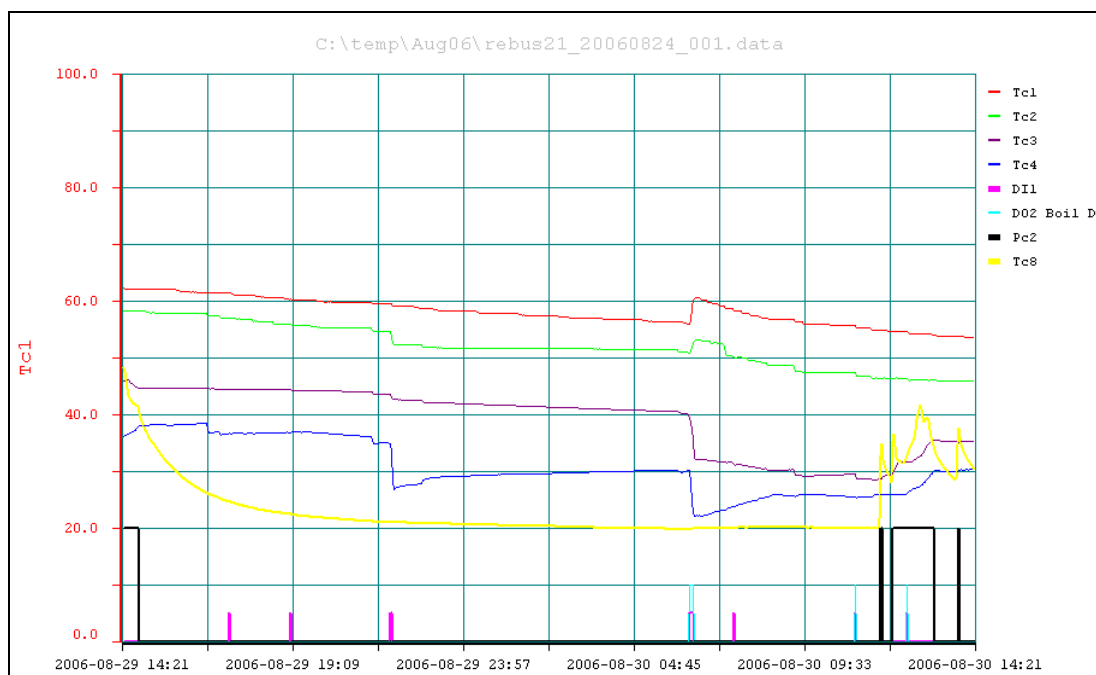

Fig. 6–25 Thermal stratification in the solar tank on a summer day with hot water preparation and with auxiliary heat demand (Tc1-Tc20 in °C / DI1, DO2_Boil_D and Pc2 are on/off signals).

In Fig. 6–26 the thermal stratification in the solar tank in a night period of 12 hours during space heating period in November is shown. The ambient temperature sensor (Tc20) measured about 10°C the whole night. The space heating forward temperature (Tc10) according to the heating curve was 45°C. The space heating return temperature (Tc11) was about 28°C, which shows that the thermostat valves at all radiators and floor heating loops were set correctly. The space heating consumption during the period 23:18 until 06:30 was 14 kWh. This corresponds to an average space heating load of about 1.9 kW with a flow rate of about 95 ltr/h.

Within this period of 7.2 hours, the natural gas boiler started only 5 times (DO1) due to the space heating demand. The very short operation at about 23:30 was due to a short hot water tapping. Since the minimum power of the natural gas boiler is about 5.5 kW, in a typical standard installation (without using an auxiliary volume) the boiler would operate in a start/stop mode with a much higher start frequency of about 6 times per hour. Further, due to the internal bypass valve (increasing the internal flow rate from 95 to about 450 ltr/h) the internal return temperature would be about 47°C instead of less than 30°C as shown by (Tc2) in Fig. 6–26.

Fig. 6–27 shows in good way how the system is able to achieve good thermal stratification in the tank and lowest return temperatures for the condensing natural gas boiler even during hot water preparation.

From 06:08 until 06:22 the boiler was heating the auxiliary volume up to 50°C in the top (Tc1) and about 48°C at the level of the sensor (Tc2). The boiler return temperature (Tc13) during this heating most of the time was less than 30°C, only in the end before switching off the boiler the return temperature increased to about 35°C. The height difference between the temperature sensor (Tc2) and the pipe 1, where the return flow (Tc13) for the boiler is taken, is only about 10 to 15 cm (see Fig. 3–4 on

page 38). The quite large difference between (Tc2) and (Tc13) of about 13 K shortly before switching off the boiler shows how good thermal stratification is built up in the tank.

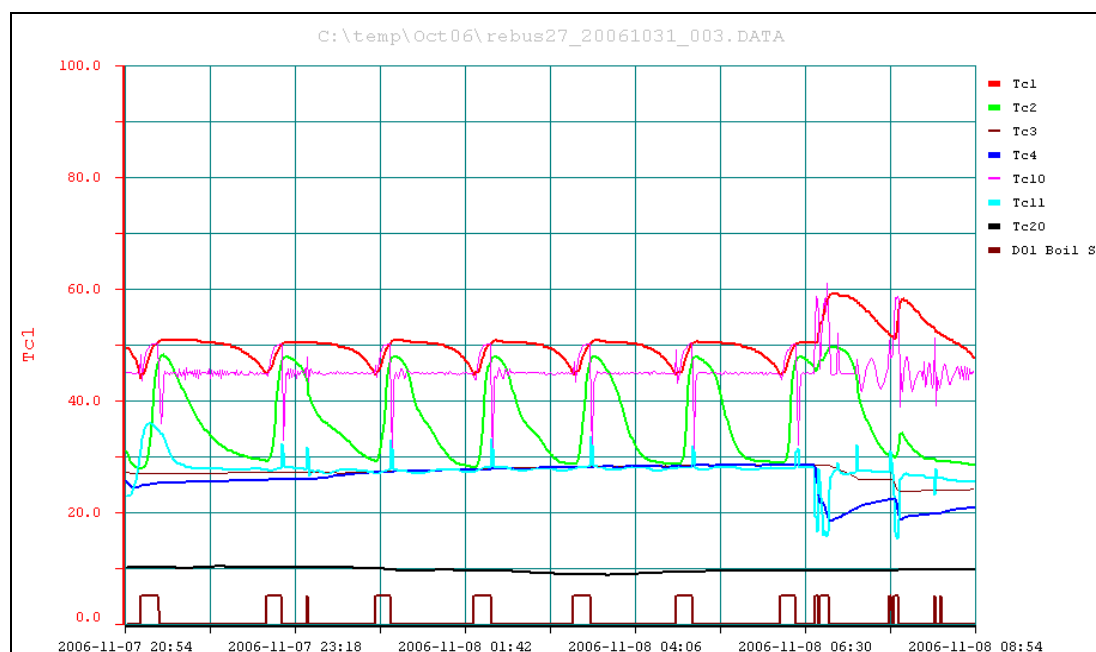

Fig. 6–26 Start/Stop frequency of the natural gas boiler with low space heating return temperature (Tc1-Tc20 in °C / DO1_Boil_S is an on/off signal).

Just a short time later at about 06:38 hot water tapping starts what forces also the boiler to start. Even that just 15 minutes before the auxiliary volume was heated up and (Tc2) still is at about 46°C, the boiler return temperature (Tc13) in the first phase for about four minutes is only 30°C. At 06:42 hot water tapping was stopped for about one minute and started again with a very low hot water tap flow rate. In this situation the 3-way valve V2 needs to open the bypass frequently a little, which leads to the oscillating behavior of the whole system. But even in this situation the boiler return temperature (Tc13) in average is at a level of about 40°C, which in theory still gives the possibility of condensation for the boiler. Since the boiler is operating very unstable, at high power and also with relative high forward temperature (Tc10) in practice the condensation rate is only very little in this case.

Finally it can be observed that during this period of hot water tapping the temperature in the bottom of the tank (Tc4) was significantly decreased to about 18°C, which is just some degrees more than the cold water temperature of the mains at that time, which was 12°C.

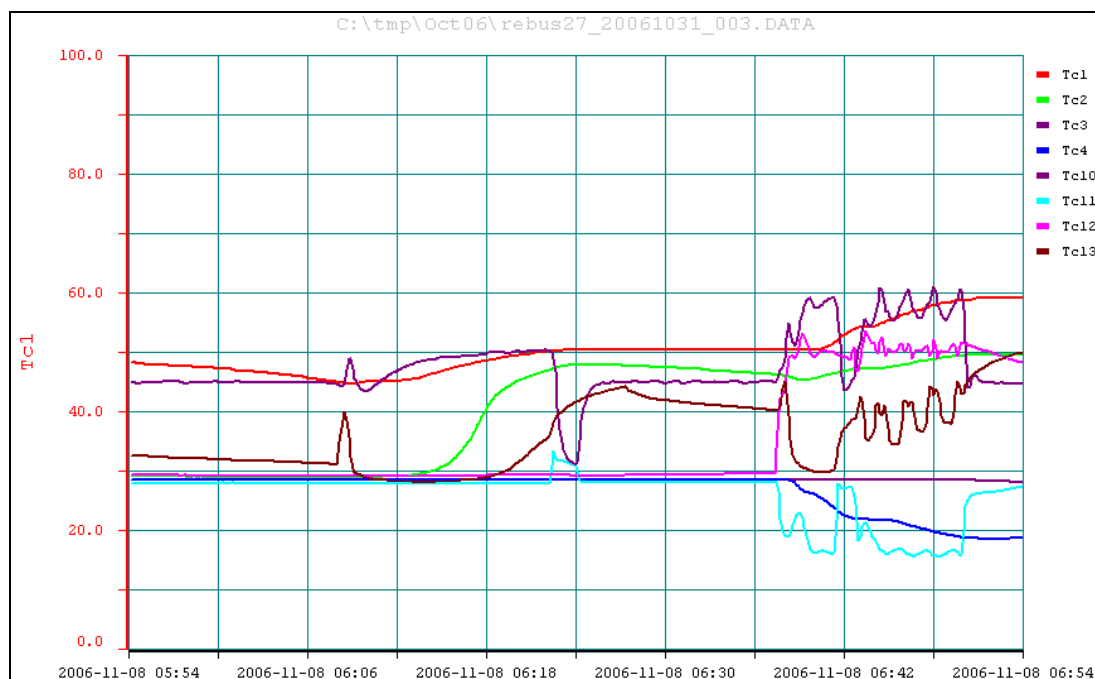

Fig. 6–27 Hot water preparation with boiler from start at high and low hot water tap flow rate and the corresponding return temperature (Tc11) leading to a drop of the tank temperature (Tc4) and the return temperature into the boiler (Tc13) leading to good condensation (Tc1-Tc20 in °C).

The following graphs show the domestic hot water preparation in all cases during space heating period with different start and/or boundary conditions.

In Fig. 6–28 after the night the first hot water tapping is shown. Since the temperature in the top of the solar tank (Tc1) is not high enough the boiler is starting immediately (DO2). The hot water tap temperature (Tc12) is increasing very fast to about 43°C, slower to about 45°C and then faster again until the set temperature of 50°C is reached. The reason for this reduced increasing speed is that the boiler at that time still is in the internal heating up phase and not connected to the hot water heat exchanger. The valve V2 allows only internal flow in the boiler loop. When the boiler is able to produce high enough temperature the valve V2 opens and the forward temperature (Tc10) is increasing to about 56°C. Due to the opening of V2 the boiler needs to adapt the power which takes some time. This is the reason why the temperature (Tc10) decreases again a little before it reaches the constant temperature of about 59°C. The devolution of the tap temperature (Tc12) shows after reaching the set temperature only very small oscillations thanks to the fast speed control of the pump P4 (Pc4_speed).

Fig. 6–29 shows again a morning shower but with preheating with the hot water circulation pump and the function “circulation on demand”. At about 06:25 with a short tapping of just one second the circulation in the hot water system is started and the pipes are heated until the temperature sensor (Tc17) reaches the switch off temperature of 40°C. The circulation pump is running about one minute. During this period it can be observed that the return temperature (Tc11) of course is at a relative high level since no cold water is tapped. Some minutes later when the shower really starts, the tap temperature (Tc12) immediately has about 50°C.

Demonstration House

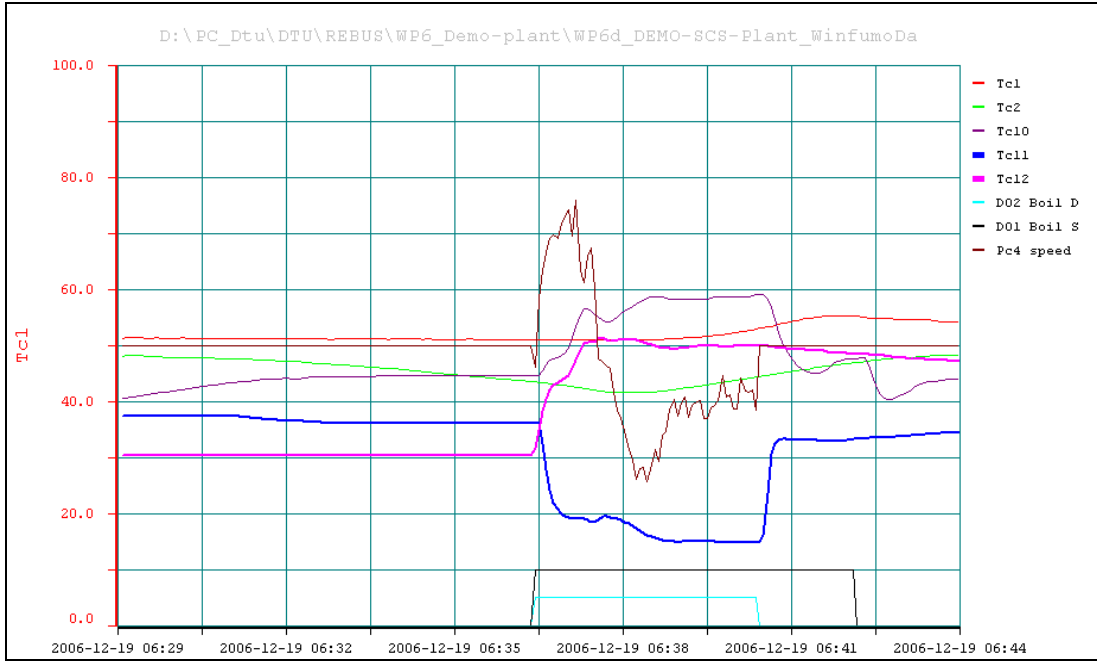

Fig. 6–28 Domestic hot water preparation for a shower in the morning during space heating with boiler support from the beginning (Tc1-Tc20 in °C / Pc4_speed in % / DO1_Boil_S and DO2_Boil_D are on/off signals).

Just due to the start procedure of the boiler the tap temperature for a short while decreases to about 45°C before it reaches the set temperature of 50°C again. During the shower, the temperature is kept exactly at 50°C. The return temperature (Tc11) during the shower which is going back to the solar tank is about 16°C, while the cold water temperature is about 10°C at that time.

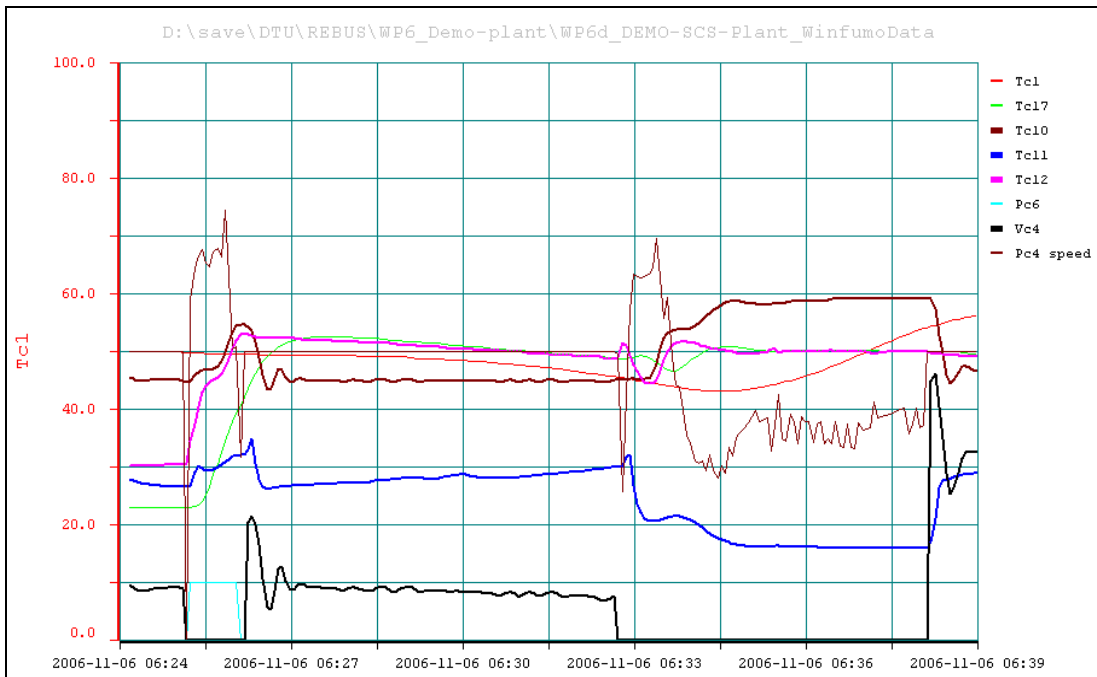

Fig. 6–29 Domestic hot water preparation for a shower in the morning during space heating with boiler support from the beginning and preheating with circulation on demand (Tc1-Tc20 in °C / Vc4 and Pc4_speed in % / Pc6 is an on/off signal).

In Fig. 6–30 a situation is shown where hot water tapping starts at about 19:13 with just sufficient high temperature (Tc1) in the solar tank. At about 19:14 the boiler has to start (DO2_Boil_D). Therefore, the forward temperature (Tc10) shows some oscillations before the boiler set temperature of about 59°C is reached. Due to the fast reacting PID controlled pump P4 (Pc4_speed) the oscillations of the tap temperature (Tc12) directly after the heat exchanger are comparable low, in fact less than $\pm 1.5\text{K}$. In practice after several meters of pipes these oscillations are damped that much that it is almost impossible to feel it.

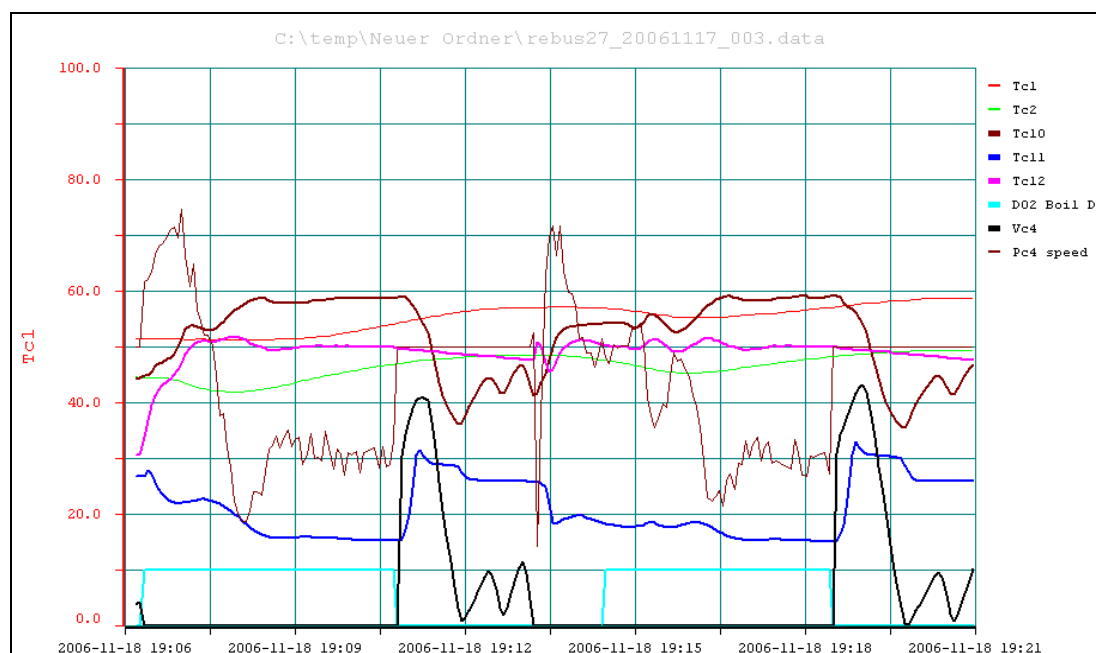

Fig. 6–30 Domestic hot water preparation with boiler start during tapping (Tc1-Tc20 in °C / Vc4 and Pc4_speed in % / DO2_Boil_D is an on/off signal).

The next example in Fig. 6–31 shows a hot water tapping with very low flow rate of about 3 ltr/min and the boiler in operation. In this situation even when the pump speed (Pc4_speed) is set to zero the boiler pump would force a too high flow rate passing the hot water heat exchanger and resulting in too high tap temperature (Tc12). To avoid this problem the valve V2 is controlled in a way, that partly the boiler forward flow is mixed to the boiler return flow and therefore reducing the pressure to the hot water heat exchanger. As a result the forward temperature (Tc10) which is produced by the boiler is oscillating quite strong, where the hot water temperature (Tc12) has much smaller amplitudes due to the fast speed controlled pump P4 (Pc4_speed). Due to this very low hot water flow rate of about 3 ltr/min it takes about 6 seconds to pass one meter pipe length (for a 3/4" pipe), which has a quite strong damping effect until the water reaches for example the shower after several meters.

In Fig. 6–32 hot water tappings are shown with strong changing of the tap flow rate. At 13:06 a short tapping of about 15 seconds takes place, followed by about one minute space heating (Vc4 is about 10%) and then again a long period of about six minutes hot water tapping. In this case in the start phase the tap temperature (Tc12) has oscillations with a relative large amplitude up to 56°C in the beginning. This happens because the boiler was initially very hot, since it was on (DO2_Boil_D) for a short moment just shortly before.

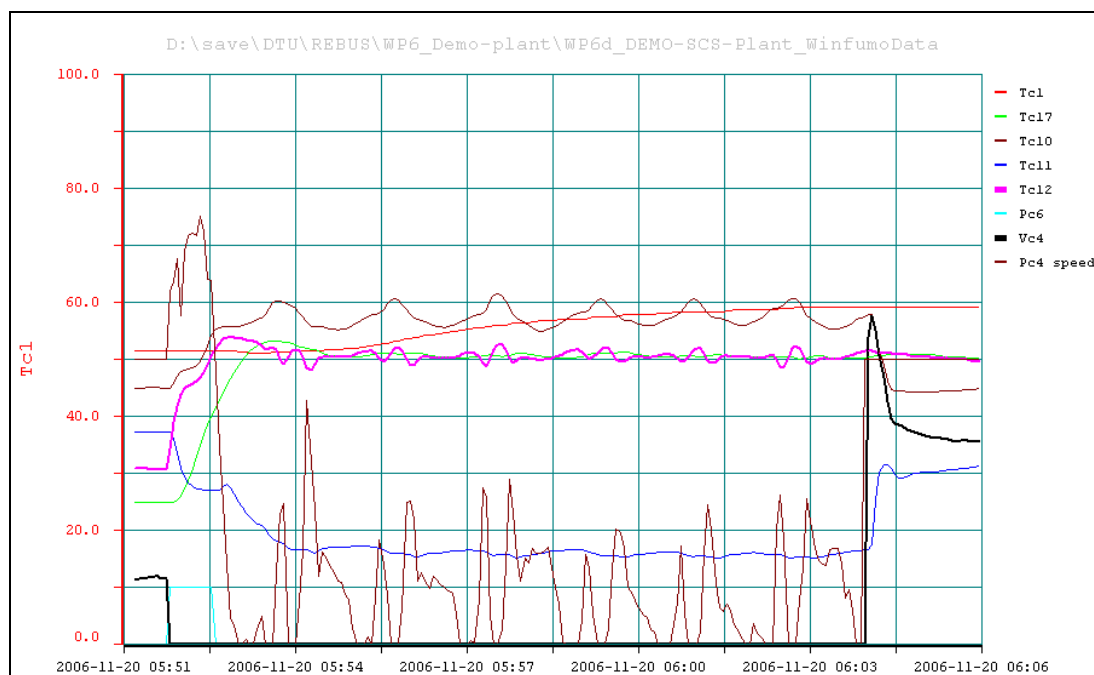

Fig. 6–31 Domestic hot water preparation with very low flow rate with boiler support (Tc1-Tc20 in °C / Vc4 and Pc4_speed in % / Pc6 is an on/off signal).

At 13:10 the system has reached constant operating conditions (Pc4_speed at about 20% and Tc10 at 59°C). At 13:11 suddenly the temperature (Tc12) is falling, obviously due to a strong increase of the hot water flow rate due to a second open tap somewhere in the house. The pump speed (Pc4_speed) immediately jumps from 20 to 60% to increase the heating power. As a result the temperature (Tc12) after a short peak down to about 47°C is quick and without oscillations increasing again to the set temperature of 50°C. At 13:12 the second tap obviously is closed again. The tap temperature (Tc12) again has a short peak up to 53°C and is reaching the set temperature of 50°C very quickly without oscillations.

Since the power of the boiler during this hot water tapping was much higher than needed, the surplus power was used to heat up the auxiliary volume to a temperature (Tc1) of 59°C. Therefore the following hot water tapping at 13:15 was powered directly from the tank and the boiler did not need to start immediately.

In Fig. 6–33 hot water tapping is shown again with large changes of the hot water flow rate but without boiler support since the temperature in the tank (Tc1) is high enough. Compared to Fig. 6–32 it can be observed that the tap temperature (Tc12) has slightly higher peaks after the change of the flow rate. The reason for this effect most likely is, that in this case the pump P4 has no support from the boiler pump and that the forward temperature (Tc10) is only 57°C instead of 59°C as before. But also in this case the tap temperature (Tc12) reaches the set temperature of 50°C very quickly and without oscillations.

Demonstration House

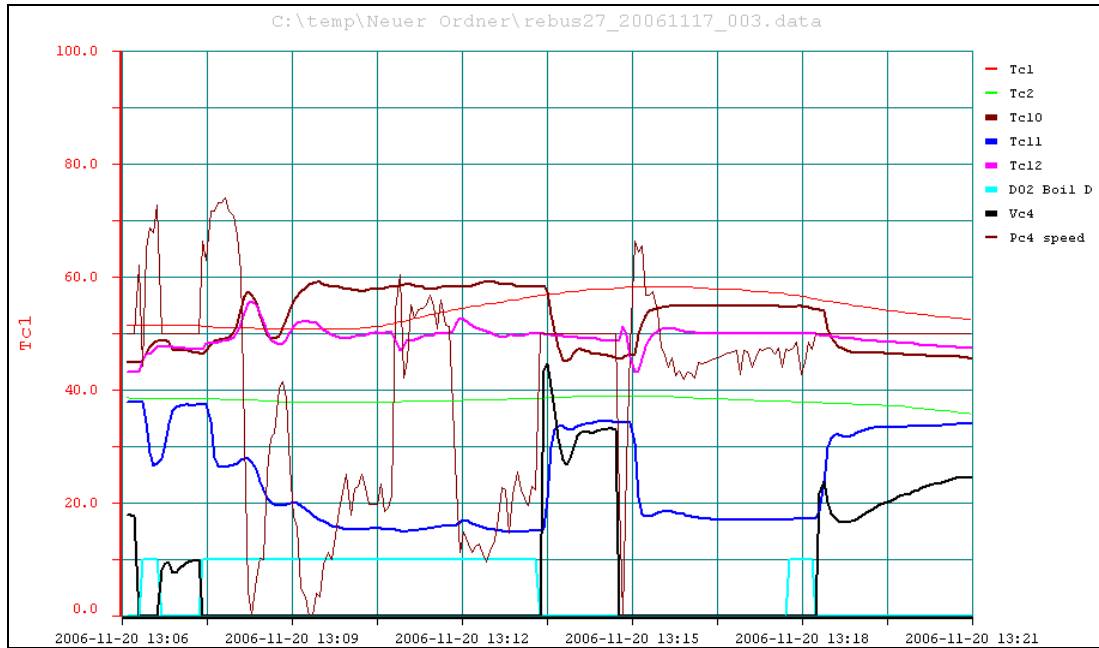

Fig. 6–32 Domestic hot water preparation with boiler support and strong changing flow rates (Tc1-Tc20 in °C / Vc4 and Pc4_speed in % / DO2_Boil_D is an on/off signal).

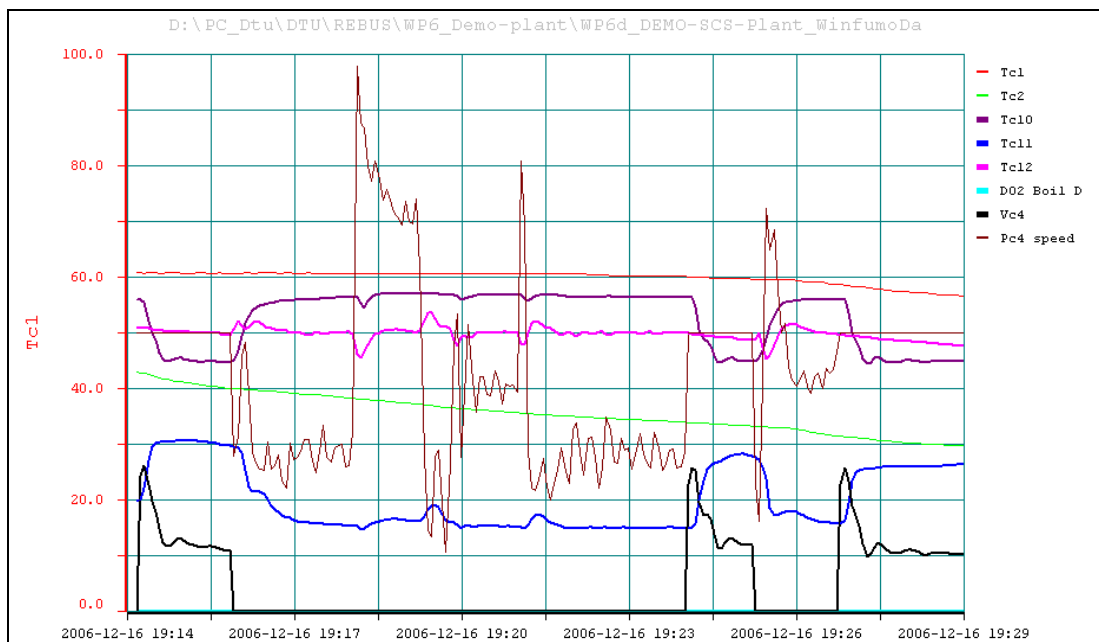

Fig. 6–33 Domestic hot water preparation without boiler support and strong changing flow rates (Tc1-Tc20 in °C / Vc4 and Pc4_speed in % / DO2_Boil_D is an on/off signal).

6.4 Comparison of Old and New Heating System

Based on several key figures shown in Table 6–3 now the old non condensing natural gas heating system and the new solar/condensing natural gas heating system will be compared. The main topics of this comparison are:

- Space heating distribution system
- Hot water preparation
- Hot water circulation
- Electricity consumption
- Key efficiency values

The data in Table 6–3 until April 2006 are measured with the old heating system, the remaining four months from October 2006 until January 2007 are measured with the new solar combisystem. Unfortunately the monitoring period for the new solar combisystem is very short. Additionally during this period also several tests were done which for example slightly increased the hot water consumption.

Table 6–3 Comparison of energy data and key figures between the old non condensing natural gas heating system and the new solar/condensing natural gas heating system.

	Ambient Temperature Average Source: DMI	Natural Gas Consumption Low Heating Value = 10.67 kWh/m ³	Solar Gain	Space Heating	Space Heating Temperature Difference Monthly average	Domestic Hot Water-Consumption	Domestic Hot Water-Consumption Average daily consumption	Domestic Hot Water Consumption Temperature Difference Monthly average	Domestic Hot Water-Circulation (21/11-05 till 20/12-05; daily 6-10 and 17-20)	Electricity consumption per day Total heating System (from 21/11-05)	Boiler Efficiency (Boiler/Gas)	Natural Gas - COP (DHW+SH)/(Gas) Circulation as Loss	Solar Fraction (Solar)/(Solar+Boiler)	Hydraulic Efficiency (DHW+SH)/(Gas+eta_boil+Solar) Circulation as Loss
	Ta	Gas	Solar	SH		DHW			Circ	Electr.	eta_boil	COP	SF	eta_hyd
	[°C]	[kWh]	[kWh]	[kWh]	[K]	[kWh]	[kWh/d]	[K]	[kWh]	[kWh/d]	[%]	[%]	[%]	[%]
08-2004	17.7	507	0	14	10.9	99	3.2	58.1	0	-	56.8%	22.3%	-	39.2%
09-2004	13.5	460	0	33	17.0	98	3.3	60.3	0	-	59.6%	28.6%	-	47.9%
10-2004	9.4	2588	0	1292	36.3	273	8.8	60.3	0	-	79.8%	60.5%	-	75.8%
11-2004	4.7	3382	0	1943	38.2	319	10.6	62.5	0	-	82.4%	66.9%	-	81.2%
12-2004	3.3	3382	0	2090	14.9	348	11.2	60.5	0	-	84.6%	72.1%	-	85.2%
01-2005	2.6	3055	0	2322	8.2	315	10.2	55.8	0	-	88.8%	86.3%	-	97.2%
02-2005	-0.3	3477	0	2665	10.3	350	12.5	57.1	0	-	89.1%	86.7%	-	97.3%
03-2005	0.9	3602	0	2822	10.4	324	10.5	57.0	0	-	89.9%	87.3%	-	97.1%
04-2005	7.8	2224	0	1685	6.6	292	9.7	54.6	0	-	92.5%	88.9%	-	96.1%
05-2005	11.0	1655	0	1207	5.7	257	8.3	52.6	0	-	93.6%	88.5%	-	94.5%
06-2005	14.1	1038	0	663	6.3	229	7.6	50.6	0	-	93.1%	85.9%	-	92.2%
07-2005	17.2	400	0	15	13.8	220	7.1	48.1	0	-	83.8%	58.8%	-	70.1%
08-2005	15.2	401	0	77	4.0	183	5.9	30.3	0	-	90.4%	64.9%	-	71.8%
09-2005	13.9	808	0	424	3.4	241	8.0	54.5	0	-	94.5%	82.3%	-	87.0%
10-2005	10.3	1890	0	1378	5.2	281	9.1	57.0	0	-	93.6%	87.8%	-	93.8%
11-2005	5.2	2926	0	2124	7.1	292	9.7	59.2	91	3.5	89.3%	82.6%	-	92.5%
12-2005	1.9	3654	0	2593	10.2	295	9.5	59.4	206	3.2	88.6%	79.0%	-	89.2%
2005		25131	0	17974	7.7	3279	9.0	52.8	-	-	90.4%	84.6%	-	93.6%
01-2006	-1.6	4639	0	3693	11.2	247	8.0	59.6	0	3.4	87.4%	84.9%	-	97.1%
02-2006	-0.2	3871	0	2978	10.1	267	9.5	61.9	0	3.3	87.2%	83.8%	-	96.1%
03-2006	-1.1	4257	0	3243	10.8	300	9.7	62.6	0	3.4	86.4%	83.2%	-	96.4%
04-2006	5.9	2928	0	2210	7.0	259	8.6	61.5	0	3.3	89.1%	84.3%	-	94.7%
05-2006	11.5													
06-2006	15.8													
07-2006	20.3													
08-2006	16.9													
09-2006	16.0													
10-2006	11.7	1266	143	1040	11.9	216	7.0	35.3	18	2.9	96.5%	99.2%	10.5%	92.0%
11-2006	7.4	2146	66	1830	12.7	238	7.9	37.4	14	3.1	99.1%	96.4%	3.0%	94.3%
12-2006	6.6	2244	27	1853	12.5	274	8.8	39.2	10	3.2	99.5%	94.8%	1.2%	94.1%
01-2007	4.3	2828	30	2421	12.3	214	6.9	39.6	14	3.2	97.8%	93.2%	1.1%	94.2%

6.4.1 Space Heating Distribution System

To compare the space heating system in absolute numbers it is important to remember that as described in chapter 6.2 (page 104) the old heating system did not heat the basement. The new heating system supplied about 28 m² gross area more (out of 172 m² total gross area) than the old heating system because the room in the basement was occupied since summer 2006.

A clear difference can be observed in the average temperature difference of the space heating circuit at similar space heating loads. In the new installed solar combisystem the space heating temperature difference (column 5 in Table 6–3) was all four months in a very small range around 12 K. In the old heating system the space heating temperature difference in average was 7.7 K for the whole year 2005. The maximum was around 10 K in the core heating season and around 5 to 7 K (or less) in spring and autumn. In 2004 the space heating controller was faulty, see Fig. 6–16 (page 111) with the explanation for that.

The explanation is the use of the thermostat valves at the radiators. During the period measured with the new solar combisystem after intensive explanations the thermostat valves were used almost correct and therefore the temperature difference in average was almost the double compared to the old system. At least in autumn 2006 it was possible to get return temperatures most of the time clear below 30°C. This is shown for example in Fig. 5–25 (page 93) where the space heating return temperature (Tc11) end of October was about 26°C. This was possible even with a forward temperature of 45°C, which is relative high for that period. In comparison Fig. 6–17 (on page 113) is an example of the old installation where at 08:00 with a forward temperature of about 45°C the return temperature was about 40°C. In the same graph also at 17:00 with a forward temperature of about 35°C the return temperature was almost 30°C.

This shows that even with an extremely bad equipped space heating distributing system the correct use of the thermostat valve can have a quite large effect. Bad equipped space heating system in this case means that:

- The radiators are old types (cast iron) designed for high temperatures.
- None of the radiators has a pre-adjusting valve; therefore the hydraulic circuit in this house is not adjusted.
- The newest and best radiator of the house unfortunately is installed in the technical room in the basement and switched off since this room is heated enough by the heat losses of the pipes and the heating system itself.
- One of the two radiators in the living room in the first floor is totally covered by a stone plate at the top and the back side of the couch in the front and therefore not able to deliver significant amount of heat to the room.
- The sleeping room in the second floor has no radiator.
- The working room in the second floor has one relative good radiator, but the thermostat valve is blocked and totally closed, therefore this radiator is not delivering any heat as well. The second radiator is a very old and heavy type, where the pipes are connected wrong: the forward pipe (with high temperature) is connected at the bottom and the return pipe is connected at the top. This radiator therefore is internally totally mixed and the temperature difference between forward and return temperature is very little.

Therefore the first floor is heated by two radiators, the second floor (except the bathroom) is heated by only one old, small radiator which also is connected wrong. This is in total quite a reduced heat transfer possibility for the whole house, why it is

consequently and natural that the remaining radiators have to take over the heat load, what is only possible at relative high average temperature level.

Based on these facts the system behavior relating to space heating return temperature in the new installed heating system is acceptable.

6.4.2 Hot Water Preparation

Comparing the hot water consumption of the same period (October until January) shows that the hot water consumption in general changed quite strong (see Table 6–4). In the old heating system obviously the hot water tank is heated to a quite high temperature of about 70°C. This is the reason why the temperature difference in the periods 1 and 2 in average is around 59 K. In the new installed solar combisystem in period 3 a temperature difference of about 38 K in average is measured, this is about 35% less. The hot water set point temperature in period 3 in the new system is 50°C. Therefore the hot water consumption in terms of liters between period 2 and period 3 is increasing even that the hot water consumption in terms of energy is decreasing.

Table 6–4 Domestic hot water consumption of three four-months periods as average daily values, each from October – January.

		DHW	DHW	Temperature difference
Period	Year	[kWh/day]	[ltr/day]	[K]
1:	2004/05	10.2	148	59.8
2:	2005/06	9.1	134	58.8
3:	2006/07	7.7	174	37.9

The hot water consumption of these three periods constantly decreased from year to year.

The reduction from period 1 to period 2 obviously is based on reduced hot water consumption in terms of liters since the temperature difference is almost the same. One main reason for that is that after summer 2005 due to illness the average number of bathes of one person decreased. No technical changes are known which could explain the difference between period 1 and period 2.

The reduction from period 2 to period 3 has several impacts. First of all the new solar combisystem was installed with the hot water flat plate heat exchanger unit for hot water preparation. This leads to the following effects:

- The flat plate heat exchanger has a relative high pressure drop, which has a remarkable effect especially at high flow rates. Therefore the flow rates are reduced leading to less hot water consumption in terms of liter and following up also in terms of energy.
- The advanced circulation strategy “circulation on demand” is introduced in the new system (see chapter 3.1.2 on page 34). Circulation pumps in general have the goal to reduce hot water consumption in terms of liter since they keep the hot water pipes hot and therefore avoid wasting of water when the user is waiting for the hot water. But this wasted water during the waiting time is measured as consumption in systems without circulation pump. Therefore in systems with circulation pump this wasted energy of the waiting time is not measured as consumption but as heat loss. In terms of energy in total, circulation pumps of course increase the energy demand for hot water preparation but reduce the hot

water energy consumption itself. This topic was studied very detailed in a master thesis project at the Solar Energy Research Center in Sweden (Apel 2005).

- The hot water temperature entering the pipes was about 70°C in the old system (period 1 and 2) but it is only 50°C in the new solar combisystem. During constant hot water tapping this makes no difference in terms of energy, if it can be assumed that the user at the tap is mixing anyway to a lower temperature. But after tapping, the hot water which stays in the pipe was measured by the heat meter as hot water consumption. This amount of water is cooling down from the high temperature level. Therefore, it is a big difference of the heat content in the pipe if the temperature is 70°C or 50°C. Compared to a room temperature of 20°C the heat content with 70°C is 67 % higher than with 50°C. This effect of course is strongly depending on the number of taps and the average durations of the tappings.

One change in the house most likely also will have some influence on the hot water consumption. In summer 2006 the basement was occupied and therefore also the bathroom with the shower in the basement since that time is in use. This is reducing the use of the bathroom in the second floor, which influences the hot water consumption because:

- The pipe lengths from the technical room to the bathroom in the basement are shorter and slightly slimmer than to the second floor, but each tap (the shower and the wash-basin) have an extra pipe coming from the technical room.
- The shower in the basement is equipped with a thermostat mixing valve and with a water saving shower head, what is not the case in the second floor.
- The tap for the wash-basin is equipped with a water saving tap, what is not the case in the second floor.

From user point of view no changes of the behavior in hot water tapping is reported beside one: since the basement is occupied by the daughter in summer 2006, her boy friend additionally was using the shower in the basement as well.

6.4.3 Hot Water Circulation

In the old heating system the hot water circulation pump was in use just for a short time of one month. The reasons for that are explained together with Fig. 6–18 (page 114). In fact during this period of 30 days in autumn 2005 the circulation heat losses of in total 297 kWh are in the same magnitude of the monthly hot water consumption at that time: 292 kWh in November and 295 kWh in December 2005.

In the new installed solar combisystem the control concept “circulation on demand” is in use (see chapter 3.1.2 on page 34). The circulation heat losses of 10 to 18 kWh per month are just a fraction compared to those before. Compared to the hot water consumption the circulation heat losses are in the magnitude of 5 to 10%.

This shows that from an energy point of view the new concept of “circulation on demand” is operating very successful. Unfortunately due to a mistake of the installer (all taps in the house are connected with parallel pipes from the technical room in the basement) only the bathroom in the second floor has advantage of the circulation pipe. Therefore the house owner is in general not very satisfied with the hot water circulation system.

6.4.4 Electricity Consumption

The daily electricity consumption of the old conventional heating system and the new solar combisystem is in the same range. The new solar combisystem in comparison to the old heating system has in total three more pumps, five more 3-way valves, one additional frequency converter and a controller, which consists in fact of 4 controllers since it is a prototype. Based on these facts it would be expected that the consumption of parasitic electricity to operate the complete system in comparison with the conventional one would be much higher.

In fact the average daily electricity consumption of the 4-month period October – January in 2006/07 (new system) is 8% lower compared to the 4-month period January – April 2006.

The reason why this is possible can be explained as following: The 3-way valves have a nominal power of only 2 to 4 Watt and they are only in operation for very short periods, in fact just some seconds. Also the frequency converter has an efficiency of at least 95 % according to the datasheet. The electricity consumption of the controller unfortunately is not known but typically around 2 to 4 Watt.

The two additional pumps for the primary and secondary solar circuit are set to the lowest power (position 1 out of 3 results in 30 W nominal power each) and they are in this period only very little in operation. Anyway, if these pumps are in operation 2,000 hours per year, this is resulting in average in about 0.32 kWh/day. This is about 10% of the total consumption of the old system. Additionally each kWh heat gained by the solar collector also reduces the electricity consumption of the natural gas boiler because this needs to operate less time. According to the test certificate of the natural gas boiler, the electricity consumption at lowest power is about 62 W, at maximum power about 119 W.

Most likely the biggest advantage of the new solar combisystem is the speed controlled space heating pump (P4) which is set to a standard speed of 50 % during space heating. Also during hot water preparation in average the pump speed is around 50 %, which is estimated based on the monitored pump speed signal. In both the old and the new system for this pump a Grundfos UPS xx/60 is used which has a nominal electricity consumption of 90 W at full speed which was also the setting in the old system. During the heating season this pump is operating 24 hours per day. A constant power of 42 W corresponds to 1 kWh within 24 hours. Therefore this is a huge potential to reduce the electricity consumption which is used in the new system due to the standard speed of 50 %.

6.4.5 Key Efficiency Values

To evaluate a solar heating system it is necessary to determine different characteristics of the system. Beside a high solar gain from the solar collector a high hydraulic efficiency is required. Otherwise it would be easy to achieve high solar gain based on high heat losses of the whole system. Also the solar fraction is a very critical key figure since it is very strong depending on the definition and therefore how the heat losses are accounted for: to be covered by the auxiliary, by the solar collector or both in a specific ratio. High boiler efficiency is the “backbone” of a high overall coefficient of performance as long as the boiler is the main heat supplier in the heating system, like it is in this case.

1. Boiler efficiency

The comparison of the boiler efficiency of the new condensing natural gas boiler with the old non condensing natural gas boiler is influenced by the age of the two boilers, the technical principle (condensing or non condensing) and the way how the boilers are integrated in the heating system (with or without an auxiliary volume). The figures in Table 6–3 (page 130) of course show quite a big difference.

The annual boiler efficiency of the about 15 years old boiler in 2005 was 90.4 %, which is a surprisingly high value. It has to be taken into account that this boiler had a repair in December 2004 whereas beside others the internal heat exchanger as a major component was replaced. For comparison, a field test in Germany (Wolff et.al. 2004) showed for seven non condensing natural gas boilers an average annual boiler efficiency of 83.4 %.

The boiler efficiency of the new condensing natural gas boiler in the four months October 2006 until January 2007 was between 96.5 % and 99.5 %.

A Danish study (Furbo et.al. 2004) presented monthly measurement results of a heating system in a one-family house with a condensing natural gas boiler. The monthly boiler efficiency was 93.0 % at 1,126 kWh natural gas consumption in May, 96.6 % at 2298 kWh natural gas consumption in April and 96.3 % at 2706 kWh natural gas consumption in October. The annual average boiler efficiency of this boiler was 96.3 % at 29,965 kWh natural gas consumption.

Fig. 6–34 shows as an example the monthly boiler efficiencies of four different natural gas boilers integrated into one-family houses in a different way:

- Conventional House DK: This is a one-family house in Denmark with a conventional heating system consisting of a condensing natural gas boiler in combination with a 160 liter hot water tank (Furbo et.al. 2004). Unfortunately no specific informations about the space heating distribution system are available for this house.
- Solar Combisystem AUT: This is a one-family house in Austria with a “Tank in Tank” solar combisystem consisting of a condensing natural gas boiler in combination with a 1,000 liter tank with an integrated 200 liter hot water tank. This solar combisystem has a floor space heating distribution system with ambient temperature controlled forward temperature and was evaluated as part of the ALTENER project “Solar Combisystems” (Ellehauge et.al. 2003). The boiler in this system is heating the top part of the tank up to 50°C (which is also the hot water set point temperature) for hot water preparation. During space heating an auxiliary volume of about 400 liter is heated to the actual set forward temperature depending on the ambient temperature.
- Demonstration Solar Combisystem – DK: This is the solar combisystem with the condensing natural gas boiler described here in this thesis.
- Demonstration Old Heating System – DK: This is the old conventional heating system with an about 15 years old, non condensing natural gas boiler in combination with a 50 liter hot water tank as described here in this thesis.

The major interesting topic in Fig. 6–34 are the differences of the boiler efficiencies of the condensing natural gas boilers. Especially the Austrian example shows that due to almost perfect operating conditions the boiler efficiency is significant higher compared to the example of a conventional heating system in Denmark. Also the four measurement points of the demonstration solar combisystem are slightly higher than the conventional heating system.

Demonstration House

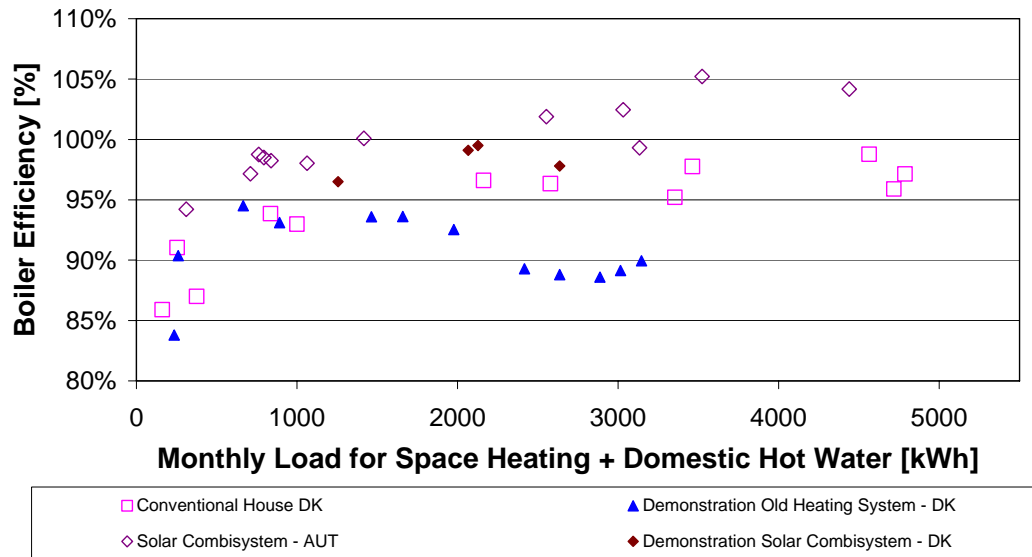

Fig. 6-34 Boiler efficiencies of heating systems in one-family houses.

The demonstration solar combisystem does not reach that high efficiencies as the Austrian example mainly due to two reasons: The old radiator space heating distribution system forces the boiler to operate at much higher temperatures. During hot water preparation in this system the boiler set point temperature of 62°C is also significantly higher, which has a strong effect (see also Table 5-2 on page 94) even that this takes place just for very short periods.

The non condensing natural gas boiler of the old heating system in the demonstration house shows a maximum at a monthly load of about 800 to 1,600 kWh. At higher load the boiler efficiency again decreases significantly. It is not clear if this is a normal behaviour or if this specific boiler had a problem at higher power. As it can also be observed in Fig. 6-15 (page 110) the boiler efficiency always was higher during spring (April until June) and autumn (September, October).

A field test in Germany (Wolff et.al. 2004) showed for 60 condensing natural gas boilers an average annual boiler efficiency of 96.4 %. More detailed analysis showed that 35 condensing natural gas boilers with an integrated bypass valve (to ensure sufficient high internal flow rate) performed in average with 94.6% compared to 99.0% of 23 boilers without such an integrated bypass valve.

The boiler type used in this new solar combisystem is such one with an integrated bypass valve. The final results after one year measurement will show the real truth, but based on the quite bad boundary conditions due to the poor space heating distributing system the results until now are looking promising.

2. Hydraulic Efficiency

The hydraulic efficiency (definition see page 118) is an important key figure. It is a requirement to achieve highest possible utilisation of the energy which is put into the system, independent if the energy is from the auxiliary heater or the solar collector. In the new installed solar combisystem the hydraulic efficiency over three months was quite constant at about 94.2 % (including the circulation heat losses!), even that the monthly natural gas consumption changed from 2,146 to 2,244 and 2,828 kWh in January.

In comparison in the old heating system the hydraulic efficiency is relative high (96 to 97 %) typically in combination with natural gas consumption more than 3,000 kWh per month, but also low (92 to 96 %) with natural gas consumption less than 3,000 kWh per month (November and December 2005 are not considered because of the temporary circulation heat losses). This is very typical due to the ratio of the hot water tank heat loss to the overall heat consumption which is changing over the year mainly depending on the space heating load.

In the new installed solar combisystem the solar tank is not heated to a defined set point temperature. In periods of low space heating demand also the average tank temperature is low (due to the heating curve) which is reducing the heat loss. Only during periods when the solar collector is able to add significant amount of heat into the tank which is stored for longer time, the hydraulic efficiency will be influenced in a negative way. Since the solar energy is for “free” (beside the used pump electricity) this disadvantage typically is more than compensated. This can be seen in the key figure “coefficient of performance” (COP).

3. Coefficient of Performance

The coefficient of performance ($COP = (SH+DHW) / \text{Gas cons.}$) informs about how much energy which has to be paid for, finally is used to cover the demand. Therefore of course all heat losses of tanks and pipes are taken into account. In heating systems like heat pumps or solar combisystems this key figure can be much higher than 100 % since energy from the environment is used for free.

In October 2006 the boiler efficiency (96.5 %) and the hydraulic efficiency (92.0 %) are the lowest of the four months, but the coefficient of performance of 99.2 % is the highest due to the solar gain of 143 kWh which covered almost totally the heat losses (153 kWh) of the system.

For a solar combisystem the period November, December and January is the worst (in northern and central Europe), since this is the period with the lowest irradiation. This new solar combisystem during this period performed in average with a coefficient of performance of 94.6 % consuming 7,218 kWh natural gas.

In a Danish study (Furbo et.al. 2004) for a conventional new heating system (installed in 2002) with a condensing natural gas boiler the coefficient of performance in the same three months was 94.6 % as well. But the natural gas consumption was much higher: 13,592 kWh, which typically is an advantage. The total annual coefficient of performance was 94.3 %.

To compare only with one reference of course is not sufficient. But the value of this comparison increases significantly, if taken into account that for this one Danish system the reported annual boiler efficiency of 96.3 % was almost exactly the same as the average of 60 condensing natural gas boilers from the German field test (Wolff et.al. 2004): 96.4 %.

Assuming that the solar gain within these three months would have been zero and the boiler would have had to supply this amount of energy ($66+27+30=123$ kWh), the coefficient of performance still would be 93.0 %. This shows that even as a conventional heating system this concept is performing very well, if taken into account that due to the integration of the solar circuit a much more complex hydraulic including a comparatively large 360 liter tank is needed, which typically causes higher heat losses.

In Fig. 6–35 and Fig. 6–36 the coefficient of performance of the four months for the solar combisystem in the demonstration house is shown in comparison to three further heating systems:

- Conventional House DK: This is a one-family house in Denmark with a conventional heating system consisting of a condensing natural gas boiler in combination with a 160 liter hot water tank (Furbo et.al. 2004).
- Solar Combisystem AUT: This is a one-family house in Austria with a “Tank in Tank” solar combisystem consisting of a condensing natural gas boiler in combination with 16 m² collector area and a 1,000 liter tank with an integrated 200 liter hot water tank. This solar combisystem has a floor space heating system and was evaluated as part of the ALTENER project “Solar Combisystems” (Ellehaug et.al. 2003).
- Demonstration Solar Combisystem – DK: This is the solar combisystem with the condensing natural gas boiler described here in this thesis.
- Demonstration Old Heating System – DK: This is the old conventional heating system described here in this thesis.

As it can be observed in Fig. 6–35 and Fig. 6–36 with an overview scale of the y-axis for all conventional heating systems the coefficient of performance is strongly decreasing at a total heat load of less than 1,000 kWh.

For the one example of a solar combisystem a total different evolution in two parts of the diagram can be observed. On the left side of the graph the coefficient of performance is increasing strongly. This is the summer period where due to the high solar gain (which is for free) the coefficient of performance is decreasing strongly. Normally it should be infinite at least in June, July and August. But as it is the case in this house, due to the wish of comfort heating in the bathroom even in summer, also in these months some auxiliary heat supply can be necessary.

Also in this solar combisystem it can be observed that in the middle of the graph (at about 3,000 kWh total load) the coefficient of performance is increasing also. This is very typically for the early spring months February and March where the space heating load is still high but also the solar gain is high at least for several days.

In Fig. 6–36 the scale of the y-axis is increased for higher resolution. Therefore, it is easier to see the difference between the two conventional heating systems with condensing and non condensing natural gas boiler. The condensing natural gas boiler has a clear higher coefficient of performance at the right side of the graph where this of course leads to higher absolute savings. The annual coefficient of performance for the system with the condensing natural gas boiler is 94.3 % compared to 84.6 % for the system with the non condensing natural gas boiler.

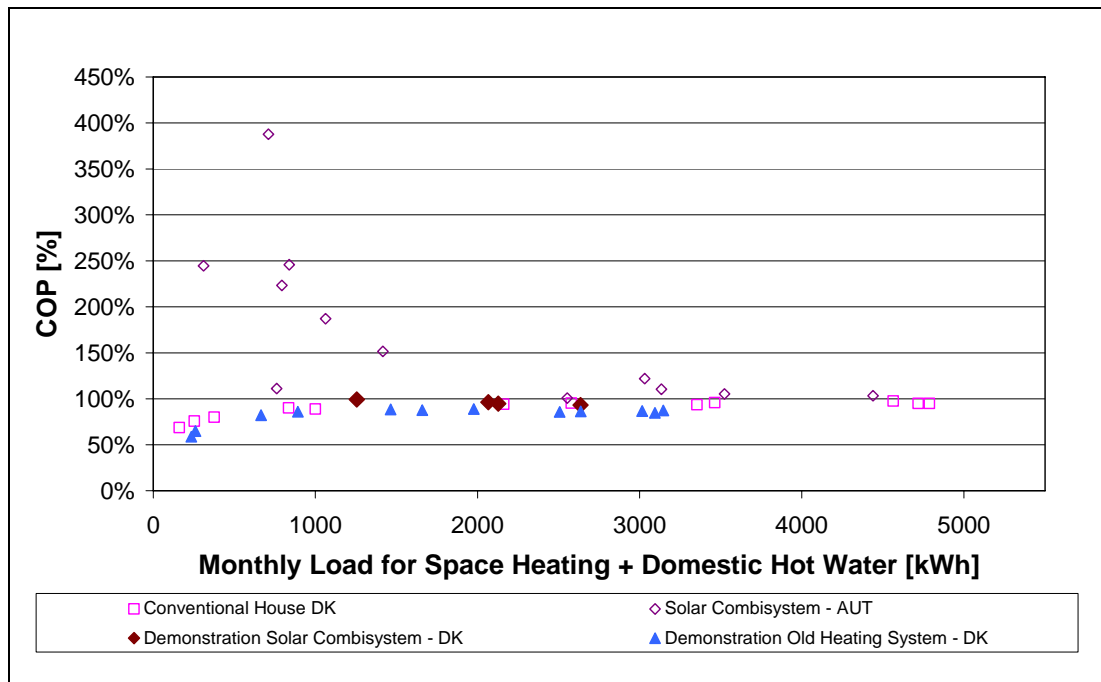

Fig. 6–35 Coefficient of performance of heating systems in one-family houses.

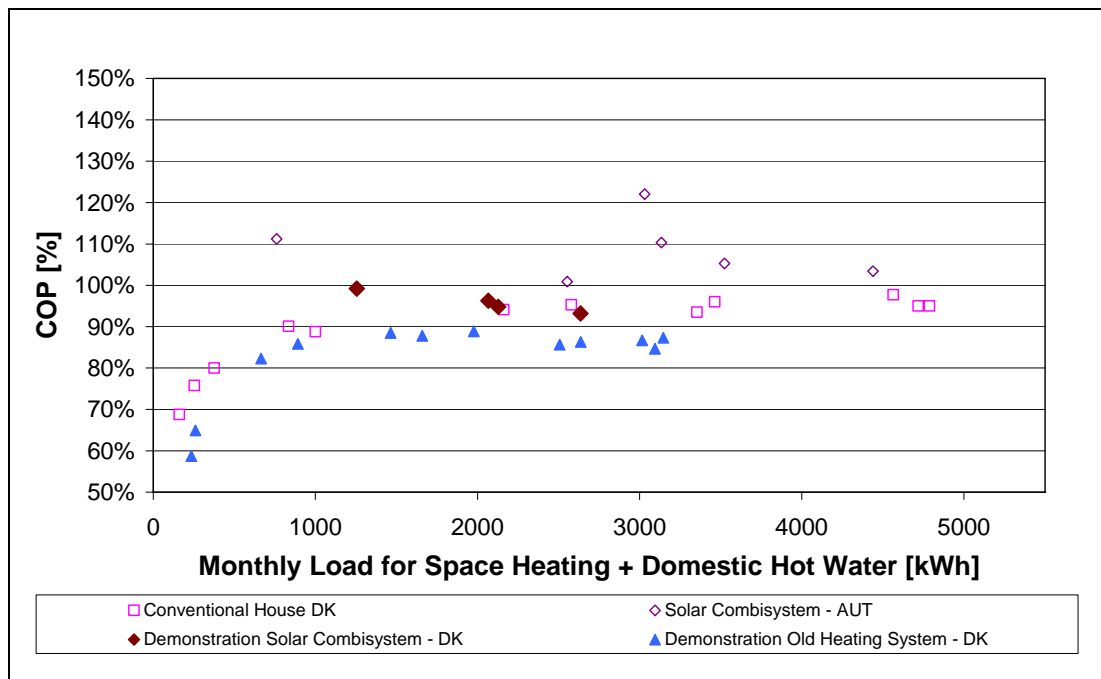

Fig. 6–36 Coefficient of performance of heating systems in one-family houses (zoom of the y-axis).

6.4.6 Energy Savings

To estimate the energy savings based on measurements in practice on the one hand side is based on realistic system behavior but on the other hand side influenced by a lot of boundary conditions which are changing over time. In this specific case the most important variable boundary conditions (beside replacing the old heating system with the new solar combisystem) are:

Demonstration House

- The weather conditions and therefore the heating degree days (HDD).
- The behavior of the occupants in terms of hot water consumption.
- The behavior of the occupants in terms of comfort wishes based on room temperature.
- Different use of the house since the basement is occupied during the measurements with the new solar combisystem and not with the old heating system.
- Different handling of the thermostat valves of the radiators due to intensive training of the occupants between the two measurement periods.

To estimate the energy savings for this four months period the following approach is used: Fig. 6–37 shows the coefficient of performance (COP) as a function of the total heat load for space heating and domestic hot water for both the old heating system and the new solar combisystem.

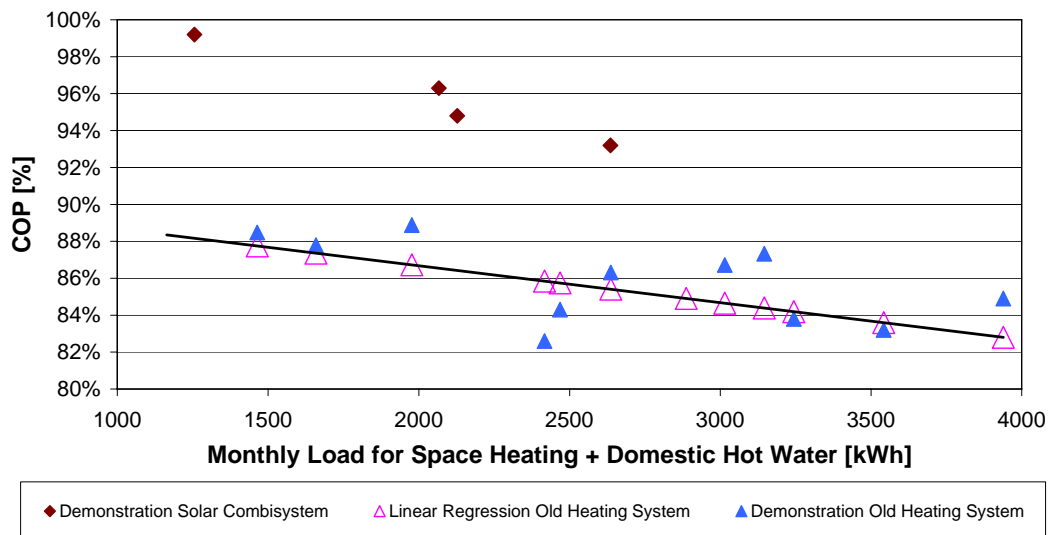

Fig. 6–37 Coefficient of performance of the new solar combisystem and the old heating system for both as measured and as calculated based on linear regression.

For this graph only those data of the old heating system are used, which have been measured during space heating period with a total load more than 1,000 kWh. For the old heating system based on these monthly measurement points a linear regression curve is fitted in a way, that using the calculated COP_{reg} based on the equation of the regression, the calculated natural gas consumption in total of all months results again in the same total natural gas consumption as measured. The equation of the linear regression COP_{reg} is:

$$COP_{reg} = 0.9068 - 0.00002 \times Load \quad \text{Eq. 6–10}$$

Based on this equation finally it is estimated how much natural gas consumption would have been used in the old heating system (Natural Gas Consumption_{reg}) based on the measured heat load of the new solar combisystem. The difference to the

measured natural gas consumption (Natural Gas Consumption_{meas}) of the new solar combisystem gives the energy savings. The result of this calculation is shown in Table 6-5.

Table 6-5 Estimation of the energy savings based on linear regression of the coefficient of performance (COP) of the old heating system.

Month	Heat Load	COP _{reg}	Natural Gas Consumption _{reg}	Natural Gas Consumption _{meas}	Energy Savings
	[kWh]	[%]	[kWh]	[kWh]	[kWh]
Oct 06	1,256	88.2	1,424	1,266	158
Nov 06	2,068	86.5	2,388	2,146	242
Dec 06	2,127	86.4	2,461	2,244	217
Jan 07	2,635	85.4	3,086	2,828	258
Total	8,086	86.4	9,359	8,484	875

It can be observed that the energy savings of the complete solar combisystem of 875 kWh was 3.3 times higher than the solar gain of 266 kWh. The average hydraulic efficiency in these four months was 93.9 %. Therefore, about 250 kWh (266 x 0.939) or about 29 % of the energy savings are due to the solar gain and 71 % are due to the higher efficiency of the condensing natural gas boiler itself but also due to the high quality of system integration.

For the total measurement period from July 7th, 2006 until January 31st, 2007 of the new solar combisystem only the natural gas consumption could be measured due to the problems with the energy meter until end of September 2006. But as an overview the natural gas consumption of the old and the new heating system can be given as shown in Table 6-6:

Table 6-6 Natural gas consumption for the period from July 7th until January 31st (208 days) for the old (2005/06) and the new (2006/07) heating system.

Natural gas consumption	
Old heating system (2005/06)	14,618 kWh
New solar combisystem (2006/07)	8,802 kWh
Difference	5,816 kWh

As mentioned before (see chapter 6.4.4 on page 134), additionally to the energy savings in terms of heat the new solar combisystem also was able to save about 8 % of the average daily electricity consumption, which is about 0.3 kWh less per day, about 9 kWh less per month, respectively.

In average the new solar combisystem consumed 3.1 kWh per day to operate the complete heating system including the space heating distribution system and the hot water circulation pump. This corresponds to an average power of 129 W or about 95 kWh per month.

According to the IEA-SHC Task 26 standard the energy savings are calculated based on a reference energy consumption depending on the total heat load. The so-called “fractional energy savings” $F_{sav,therm}$ is defined as (Weiss et.al. 2003):

$$F_{sav,therm} = \frac{E_{ref} - E_{SCS}}{E_{ref}} \quad \text{Eq. 6-11}$$

$$E_{ref} = \frac{Q_{DHW} + Q_{SH} + Q_{loss}}{\eta_{ref}} \quad \text{Eq. 6-12}$$

$$Q_{loss} = 0.00016 * \sqrt{0.75 * V_D} * (T_T - T_a) * 8760 \quad \text{Eq. 6-13}$$

Where:

E_{ref}	Final energy consumption of the (conventional) reference system [kWh]
E_{SCS}	energy consumption of the solar combisystem [kWh]
Q_{DHW}	Domestic hot water load [kWh]
Q_{SH}	Space heating load [kWh]
Q_{loss}	Heat losses from the reference heating system for one year [kWh]
V_D	Average daily hot water consumption [Liter/day]
T_T	Set point temperature of the hot water tank [°C]: 52.5°C is used for this in Task 26
T_a	Ambient temperature around the hot water tank [°C]: 15°C is used for this in Task 26
η_{ref}	Efficiency of the auxiliary heater in the reference system [%]: 85 % is used for this in Task 26

According to the measurements of the new solar combisystem the following energy loads have to be taken into account for this period of four months to calculate the final energy consumption of the reference system:

Q_{SH}	7,144 kWh	(see Table 6-3, page 130)
Q_{DHW}	942 kWh	(see Table 6-3, page 130)
V_D	174 Liter/day	(see Table 6-4, page 132)

The heat loss of the reference heating system therefore is:

$$Q_{loss} = 0.00016 * \sqrt{0.75 * 174} * (52.5 - 15) * 2952 = 202 kWh \quad \text{Eq. 6-14}$$

The final energy consumption for the reference system therefore is:

$$E_{ref} = \frac{942 + 7144 + 202}{0.85} = 9751 kWh \quad \text{Eq. 6-15}$$

The energy savings therefore are calculated to:

$$E_{ref} - E_{SCS} = 9751 - 8484 = 1267 \text{ kWh} \quad \text{Eq. 6-16}$$

The “fractional energy savings” $F_{sav,therm}$ for this period of four months therefore is calculated to:

$$F_{sav,therm} = \frac{9751 - 8484}{9751} = 13 \% \quad \text{Eq. 6-17}$$

The energy savings of the two different calculation methods are quite different: 875 kWh compared to 1,267 kWh. The measured coefficient of performance in the conventional heating system in the demonstration house was 86.4 % were the assumptions in Task 26 lead to 82.9 %. One reason for this is that in Task 26 the annual boiler efficiency (85 %) is assumed for a full year operation, including the summer period which typically is decreasing the average efficiency. Additionally the measured annual boiler efficiency in the demonstration house was 90.4 %, therefore also significant higher than 85 % as assumed in Task 26.

Demonstration House

7. Conclusions and Suggestions for Further Investigations

A new hydraulic and control concept for a solar combisystem was developed. A prototype for the laboratory was built and tested, and finally a demonstration system was installed and measured in practice. The main goal was to develop a concept in combination with a standard condensing natural gas boiler, which leads to an overall coefficient of performance as high as possible. Based on the fact that such condensing natural gas boilers are powerful enough for direct hot water preparation, the new developed concept avoids heating up the auxiliary volume to high temperatures, which is normally done just to have a buffer for hot water preparation. The new strategy leads to lower average temperature in the solar tank, and more importantly, in the piping within the system, which further on significantly reduces the system heat losses. The major problem, which had to be solved, was to ensure hot water preparation with constant tap temperature during the always changing operating conditions.

7.1 Conclusions

Naturally within this project most of the goals, but not all, could be achieved. It was possible to solve the most critical part, which was the fully automatic controlled integration of the condensing natural gas boiler. This could be solved in a way that, during all situations, the tap hot water temperature is kept within comfort limits. Further on, the control algorithm could be improved to ensure lowest possible return temperature also very short time after the start of hot water preparation.

An advanced strategy how to control a hot water circulation pump could be introduced within this concept very successfully. The circulation heat losses in the demonstration house were less than 10 % compared to the hot water consumption.

The very high overall hydraulic efficiency of the developed compact solar combisystem in the space heating period could be demonstrated successfully as well. The new solar combisystem with a 360-liter tank achieved a hydraulic efficiency of around 94 %, whereas the conventional heating system with a 50-liter hot water tank achieved around 95 % to 96 % at comparable total heat loads.

A major contribution to this success is the compactness of the hydraulic system, which is installed within a closed 60 x 60 cm cabinet, and a new designed 360-liter tank with a comparable low heat loss coefficient of about 2 W/K, thanks to a totally closed insulation at the top and the side of the tank.

The advanced hydraulic integration of a standard condensing natural gas boiler was demonstrated as well, at least within a short measurement period of four months. The monthly boiler efficiency of the boiler in the new solar combisystem performed one to two percentage points higher than a comparable example of a condensing natural gas boiler with direct connection to the space heating system. This is a remarkable result especially since the space heating distribution system in the demonstration house had

Conclusions

relatively bad characteristics, which means that the average operation temperature was relatively high.

The overall coefficient of performance of the whole solar combisystem, even as a conventional heating system with almost no solar energy contribution, was demonstrated to be in the same range as conventional, modern heating systems based on condensing natural gas boilers. Therefore it looks promising that this solar combisystem is able to use most of the energy, gained by the solar collector, to supply the heat to the load and not to cover additional heat losses, due to a more complex and larger hydraulic system. The final results of a full one-year measurement period, ending in September 2007, hopefully will verify the promising results that were achieved till now.

After the first four month measurement period (October - January) the energy saving of the new solar combisystem compared to the old conventional natural gas heating system was 875 kWh or minus 9 % respectively. The collector gain (6.75 m^2) during this period was 266 kWh.

Due to the much higher efforts of laboratory work, unfortunately it was not possible to do all theoretical simulation studies as planned. Anyway, the basic principle concept was modelled and annual calculations were done, showing that especially for small solar combisystems the potential of improvements due to this concept is large. Up to 80 % higher energy savings compared to a conventional solar combisystem with comparable hydraulic design were estimated. More detailed simulation studies would be interesting and will be proposed in the following chapter.

The practical experience in the demonstration house showed again that there is a big demand in education of all actors dealing with heating systems, most important installers and occupants. Unfortunately the awareness of the importance of correctly installed, adjusted and operated space heating distribution systems is not in the mind of most of the persons dealing with heating systems in one-family houses. Especially for solar combisystems and condensing natural gas boilers, the coefficient of performance is strongly influenced by the quality of the space heating distribution system which is responsible for the needed low return temperature. Therefore it is a must to improve dramatically the knowledge of how to use thermostat valves correctly and how to adjust the hydraulic circuit in a space heating distribution system.

The experience in the demonstration house showed that, after learning how to use the thermostat valves correctly, beside the higher system efficiency, also the occupants realized a much higher comfort in the house due to much more stable room temperatures.

Since the task, to educate that many people, is quite a big one, it should be a topic of future investigations and research with the goal to find new technologies and/or control concepts, which can improve the behavior of the space heating distribution systems and achieve lower return temperatures. Possible approaches will be given in the following.

7.2 Suggestions for Further Theoretical Investigations

The main task within this Ph.D. project was concentrated on laboratory work to find practical solutions for several details of the new concept to be able to show that the concept works in practice. Therefore only little time could be spent in doing annual calculations and parameter studies with the simulation model. Also the simulation model itself should be improved in some details in order to fit best possible to the system installed in the demonstration house. Based on this improved simulation model, a lot of interesting studies could be done.

First of all after termination of the one year measurement period of the demonstration system in September 2007, annual calculations based on measured load and weather data should be done and compared with the measurement results in order to evaluate the simulation model. For comparison reasons with the evaluated simulation model, annual calculations should be done with the same weather and load files as used within the IEA-SHC Task 26.

How to operate best the solar collector circuit? Is it best to use the constant low flow principle in combination with the existing 3-way valve or with a stratifier in the tank, or would an advanced matched flow control algorithm achieve highest energy savings. These questions might get different answers for small, medium or large sized solar combisystems. For small sized systems also a mantle tank might be a very promising and efficient solution.

The technical unit is built in a way that the combustion air for the natural gas boiler can be sucked through the cabinet. This in fact is a kind of heat recovery since the heat losses of all components inside the cabinet are used for preheating the combustion air. It would be interesting to extend the simulation model with the goal to study and quantify this effect theoretically.

The space heating return temperature has a high influence on the system performance. Till now it is the strategy to handle in a best way the return temperature as it is. Typically, for that reason, different kinds of stratifiers are developed and used in the tank.

But it should be the goal to control the space heating return temperature in such a smart way that stratifiers are not necessary. For that reason different strategies could be investigated. In this new solar combisystem the space heating pump is speed controlled for hot water preparation. This feature also could be used during space heating. A possibility, for example, could be to control the pump speed in a way that, depending on the measured ambient temperature, the set point return temperature is ensured.

Further on, it seems to be interesting to investigate new strategies how to control the space heating forward temperature. If the sun is shining through the windows, this is resulting in a remarkable additional heat source. If this fact is measured, in a way, the space heating forward temperature could be adapted much faster.

Another idea could be to use the space heating return temperature as an indicator of the actual space heating load. If the return temperature increases, this typically means that the thermostat valve opens to increase the power of the radiator. This information could be used to increase the power by raising the space heating forward temperature

and in parallel reducing the pump speed to avoid an increase of the return temperature.

As proposed in the next chapter, some simplifications of the solar combisystem should be achieved in order to make the system simpler. One idea is to replace the advanced controlled mixing valve (V4) by a simple self acting mixing valve with a fixed temperature setting at about 60°C, which fits for hot water preparation. In such a case the space heating distribution system is supplied with a forward temperature of 60°C or less, depending on the temperature in the solar tank. The space heating power in that case must be controlled only based on the flow rate. Based on simulation studies, it would be interesting to analyse the influence on such a control strategy. Since the natural gas boiler can be automatically controlled on two different temperature levels, this could be an interesting alternative.

The same principle is successfully used in multi-family houses with solar heating systems in combination with so-called two-pipe systems which are operated with a constant forward temperature between 60°C and 65°C (Heimrath 2004).

7.3 Suggestions for System Simplifications and Improvements

The solar combisystem installed in the demonstration house in fact is the second prototype, and therefore not optimized. Several possibilities could be tested in order to improve and simplify this system.

The mixing valve (V4) which is used till now is a quite expensive and fast reacting valve, controlled by the controller. After several simplifications and improvements of the control algorithm, it seems that it is possible to replace this valve by a fast reacting self acting valve. In that case the task of this valve is reduced just to ensure that the forward temperature is limited to a maximum value. Lower temperatures, needed for space heating, can be directly controlled via the natural gas boiler that can be operated at least at two different temperature levels.

Also the 3-way valve (V2), which is controlling the boiler flow, maybe could be replaced by a cheaper one. In the case of condensing natural gas boilers with integrated bypass, this valve maybe could be replaced by a much simpler 2-way valve. The highest potential of cost reduction would be if, in co-operation with a producer of condensing natural gas boilers, the speed of the internal boiler pump could be controlled according to the needs of the solar combisystem concept. In this case the valve (V2), most likely, could be omitted.

An important step of improvement could be if condensing natural gas boilers can be used with much lower peak power, but still without keeping the auxiliary volume at high temperature. If the hydraulic concept is adapted in a way that the boiler return flow during hot water preparation is coming from the highest point in the tank, then the boiler is used only as an “after heater” and would not need such a high power to fulfil the hot water demand. During space heating such a small sized condensing natural gas boilers (peak power of e.g. 10-15 kW) could modulate to much lower powers (2-3 kW) resulting in higher average boiler efficiency and lower investment costs.

Conclusions

The internal control algorithm till now forces a coordinated change of a system parameter in the controller and the set point forward temperature at the boiler itself. This control algorithm should be changed in a way that the boiler is switched off if the auxiliary volume is fully heated up, independent of the boiler forward temperature. After this adaptation, it would be possible to use the boiler integrated controller which controls the space heating forward temperature depending on the ambient temperature. Alternatively, as a low cost solution, it also would be possible that the operator during the heating season from time to time adjusts the setting manually. Of course this does not influence the forward temperature supplied to the space heating distribution system if the controlled mixing valve (V4) is in use.

Since the hot water temperature is controlled by the controller, it would easily be possible to define two different hot water set temperatures: A low level standard temperature (e.g. 40°C) and a high “kitchen” level (e.g. 50°C). With a simple electrical switch in the kitchen the high temperature could be chosen. This would have a quite big influence on the average boiler efficiency because to prepare hot water at 40°C can be achieved with 50°C primary forward temperature. As it could be shown in this thesis, this is an important difference for the efficiency achieved by a condensing natural gas boiler. Further, the utilization of the stored solar energy in the solar tank would be increased and the boiler would start later since lower temperature in the tank is sufficient for the hot water preparation at standard temperature level.

Conclusions

8. References

Andersen, E., Furbo, S. (2005), "Investigations of Solar Combisystems", Proceedings for Solar World Congress 2005, Orlando, USA

Andersen, E., Furbo, S. (2006), "Investigations of medium sized solar combi systems", Proceedings for Eurosun 2006 conference, Glasgow, Scotland

Andersen, E., Furbo, S. (2007), "Theoretical comparison of solar combi systems and stratification design options", In: Solar Energy Engineering, in press

Apel, J. (2005), "Vergleich von Zirkulationsstrategien für den Trinkwasserkreislauf in einem solaren Kombisystem", Diplomarbeit, Fachhochschule für Technik und Wirtschaft, Berlin, Germany

Bales, C. (2002a), "Generic System #11: Space Heating Store with DHW Load Side Heat Exchanger(s) and External Auxiliary Boiler", IEA-SHC Task 26, Appendix 6, http://www.iea-shc.org/outputs/task26/C_App6_System11.pdf

Bales, C. (2002b), "Generic System #12: Space Heating Store with DHW Load Side Heat Exchanger(s) and External Auxiliary Boiler (Advanced Version)", IEA-SHC Task 26, Appendix 7, http://www.iea-shc.org/outputs/task26/C_App7_System12.pdf

Bony, J. & Pittet, T. (2002), "Generic System #8: Space Heating Store with Double Load-Side Heat Exchanger for DHW", IEA-SHC Task 26, Appendix 4, http://www.iea-shc.org/outputs/task26/C_App4_System8.pdf

Datataker, Data Electronics (Aust.) Pty. Ltd., Rowville, Australia, <http://www.datataker.com/>

Drück, H. & Pauschinger, T. (1996), "TRNSYS Type 140, Multiport Store Model", ITW, University Stuttgart, Germany

DS 439 (2000), "Norm for Vandinstallationer", Dansk Standard, Charlottenlund, Denmark

Duff, W., Ed., (1996), "Advance Solar Domestic Hot Water Systems", IEA-SHC Task14 Final report, http://www.iea-shc.org/outputs/task14/task_14_Advanced_solar_domestic_hot_water_systems_full.pdf

Ellehaug, K. (2002), "Generic System #2: A Solar Combisystem Based on a Heat Exchanger between the Collector Loop and Space Heating Loop", IEA-SHC Task 26 Appendix 1, http://www.iea-shc.org/outputs/task26/C_App1_System2.pdf

Ellehaug, K. (2003), "Final Report Solar Combisystems", ALTENER project No: 4.1030/C/00-002/2000, <http://elle-kilde.dk/altener-combi/index.htm>

References

- Fawer, M. (2005), "Solar Energy 2005 - Silicon supply bottleneck at odds with booming demand", Bank Sarasin & Co. Ltd., Basel, Switzerland
- Fiedler, F. (2006), "Combined Solar and Pellet Heating Systems - Studies of Energy Use and CO-emissions", Ph.D. Thesis, Mälardalen University, Västerås, Sweden
- Furbo, S. (1994), "Beregnete ydelser for solvarmeanlæg med cirkulationsledning", Rapport nr. 94-07, Laboratoriet for Varmeisolering, Danmarks Tekniske Højskole
- Furbo, S., (2004), "Hot Water Tanks for Solar Heating Systems", Report No R-100, BYG.DTU, Denmark
- Furbo, S., Andersen, E., Thür, A., Shah, L.J., Andersen, K.D. (2005), "Advantages by discharge from different levels in solar tanks", in: Solar Energy 79 (5), pp. 431-439
- Furbo, S., Shah, L.J., Christiansen, C.H., Frederiksen, K.V. (2004) "Kedelevktiviteter for oliefyr og naturgaskedler i enfamiliehuse", Rapport nr. R-072, BYG.DTU, Denmark
- Grundfos-A, "Grundfos Heizungsumwälzpumpen", Grundfos GmbH, Erkrath, Germany
- Grundfos-B, "Grundfos Instructions UPE Series 2000", Grundfos Management A/S, Bjerringbro, Denmark
- Heimrath, R. (2004), "Simulation, Optimierung und Vergleich solarthermischer Anlagen zur Raumwärmeversorgung für Mehrfamilienhäuser", Ph.D. Thesis, IWT TU-Graz, Austria
- HNG (2006), "ØVRE BRÆND-VÆRDI", HNG I/S, Søborg, Denmark, <http://www.hng.dk/hng/naturgasnetdk.asp>
- Huizenga, C. et.al. (2003), "THERM Finite Element Simulator", Version 5.2.14, University of California
- Informationszentrum Energie (2000), "Brennwertnutzung - Energiesparende und umweltschonende Wärmeerzeugung", Landesgewerbeamt Baden-Württemberg, Stuttgart, Germany
- Jordan, U. & Vajen, K. (2002), "Influence of the DHW profile on the fractional energy savings - a case study of a solar combisystem", In: Solar Energy 73 (1), 33-42, Elsevier, London
- Jähnig, D. (2002), "Generic System #15: Two Stratifiers in a Space Heating Storage Tank with an External Load-Side Heat Exchanger for DHW", IEA-SHC Task 26 Appendix 8, http://www.iea-shc.org/outputs/task26/C_App8_System15.pdf
- Kovacs, P. & Sandberg, M. (1998), "Results from Testing of small Heat Stores for Domestic Hot Water and Space Heating", Proceedings for Eurosun 1998 conference, Portoroc, Slovenia

References

Laing GmbH Systeme für Wärmetechnik, "Montage- und Betriebsanleitung für Laing Gleichstrompumpen Baureihe Ecocirc", Remseck, Germany, www.laing.de

Lorenz, K., Bales, C., Persson, T. (2000), "Evaluation of Solar Thermal Combisystems for the Swedish Climate", Proceedings for Eurosun 2000 conference, Copenhagen.

Motron A/S, "Instruction Manual FC750-SP55", Risskov, Denmark, www.motron.dk

Schweitzer, J., (2004), "Milton Smart Line HR24 - Test report 726.62 NE05", Danish Gas Technology Center, Hørsholm, Denmark

Shah, L.J. (2002), "Generic System #4: DHW Tank as a Space-Heating Storage Device", IEA-SHC Task 26, Appendix 3, http://www.iea-shc.org/outputs/task26/C_App3_System4.pdf

Streicher, W. & Heimrath, R. (2003), "Structure of the Reference Buildings of Task 26", IEA-SHC Task 26, Subtask C, TU-Graz, Austria, http://www.iea-shc.org/outputs/task26/C_Streich_Refbuilding.pdf

Suter, J.M., Letz, T., Weiss, W., Inäbnit, J. (2000), "Solar Combisystems in Austria, Denmark, Finland, France, Germany, Sweden, Switzerland, the Netherlands and the USA", IEA-SHC Task 26, http://www.iea-shc.org/task26/bro/bro_ix.htm

TA (2006), "Freiprogrammierbare Universalregelung UVR1611", Technische Alternative Ges.mbH., Amaliendorf, Austria, www.ta.co.at

Tepe, R. & Bales, C. (2003), "Simulation Study of a Dream Systems", Technical Reports of Subtask C, IEA-SHC Task 26, <http://www.iea-shc.org/task26>

Theiß, E. (2001), "Brennwerttechnik für den Praktiker", Pflaum, München, ISBN 3-7905-0818-7

Thür, A. & Furbo, S. & Shah, L.J. (2006), "Energy Savings for Solar Heating Systems", In: Solar Energy 80 (11), 1463-1474, Elsevier, London, ISSN: 0038-092X.

Thür, A. & Furbo, S. (2005), "Investigations on Design of Heat Storage Pipe Connections for Solar Combisystems", Proceedings for NorthSun 2005, Vilnius, Lithuania

Trinkwasserverordnung (2001) "DVGW Arbeitsblatt W551", DVGW Deutsche Vereinigung des Gas- und Wasserfaches e.V., Bonn, Germany

TRNSYS 16 (2004), The Board of Regents of the University of Wisconsin System, <http://sel.me.wisc.edu/trnsys/>

Warmerdam, J., Caris, R. (2001), "Proceedings IEA Workshop Legionella", Delft on April 2nd, IEA-SHC Task 26, http://www.iea-shc.org/outputs/task26/industry_workshop_delft.pdf

References

Weiss, W. & Bergmann, I. & Faninger, G. (2006), "Solar Heat Worldwide - Markets and Contribution to the Energy Supply 2004", IEA-SHC, <http://www.iea-shc.org>

Weiss, W. (Ed.) (2003), "Solar Heating Systems for Houses - A Design Handbook for Solar Combisystems", James&James, London, <http://www.shop.earthscan.co.uk/>

Wolff, D., Teuber, P., Budde, J., Jagnow, K. (2004), "Felduntersuchung: Betriebsverhalten von Heizungsanlagen mit Gas-Brennwertkesseln", Fachhochschule Braunschweig Wolfenbüttel, Wolfenbüttel, Germany, <http://www.delta-q.de/servlet/PB/show/1024790/bericht%20cd.pdf>



Report no R-160

ISSN 1601-2917

ISBN 978-87-7877-234-3