

Technical University of Denmark



The influence of applied tensile stress on power loss in Co-rich amorphous Co-Fe-Si-B ribbons with induced magnetic anisotropy

Nielsen, H; Nielsen, K; Nielsen, Otto V

Published in:
I E E Transactions on Magnetics

Link to article, DOI:
[10.1109/TMAG.1982.1061929](https://doi.org/10.1109/TMAG.1982.1061929)

Publication date:
1982

Document Version
Publisher's PDF, also known as Version of record

[Link back to DTU Orbit](#)

Citation (APA):
Nielsen, H., Nielsen, K., & Nielsen, O. V. (1982). The influence of applied tensile stress on power loss in Co-rich amorphous Co-Fe-Si-B ribbons with induced magnetic anisotropy. *I E E Transactions on Magnetics*, 18(3), 904-907. DOI: 10.1109/TMAG.1982.1061929

DTU Library

Technical Information Center of Denmark

General rights

Copyright and moral rights for the publications made accessible in the public portal are retained by the authors and/or other copyright owners and it is a condition of accessing publications that users recognise and abide by the legal requirements associated with these rights.

- Users may download and print one copy of any publication from the public portal for the purpose of private study or research.
- You may not further distribute the material or use it for any profit-making activity or commercial gain
- You may freely distribute the URL identifying the publication in the public portal

If you believe that this document breaches copyright please contact us providing details, and we will remove access to the work immediately and investigate your claim.

CONCLUSION

Whereas it is common practice to set off-diagonal terms in the permeability tensor to zero, experimental data and analysis have been presented that justify this assumption. Moreover, important information on the transverse characteristics of the three most common permanent magnets will help to improve field computation. The values of μ'_t for Alnico 5 and 5-7 are particularly high compared to μ'_p , as was the case for recoil permeability, and this would tend to enhance transverse flux in a magnet that directly experiences armature reaction in an electrical machine. If an exact model of a permanent magnet is required, then the rotation of M_0 is found using (15) or (20).

REFERENCES

- [1] A. Wexler, "Finite-element analysis of inhomogeneous anisotropic reluctance machine rotor," *IEEE Trans. Power App. Syst.*, PAS-92, pp. 145-149, 1973.
- [2] K. J. Binns and M. A. Jabbar, "Computation of the magnetic field of permanent magnets in iron cores," *Proc. Inst. Elec. Eng.*, vol. 122, pp. 1377-1381, 1975.
- [3] J. Slomczynska, "Non-linear analysis of the magnetic flux distribution in the magnetized magnet stabilized in air," *IEEE Trans. Magn.*, vol. MAG-10, pp. 1109-1113, 1974.
- [4] H. Zijlstra, *Experimental Methods in Magnetism*. New York: North-Holland, 1967, pp. 168-208, part 2.
- [5] G. C. Grimwood, A. M. Campbell, and J. E. Evetts, "Rotational hysteresis in polycrystalline alloys," *IEEE Trans. Magn.*, vol. MAG-14, pp. 359-361, 1978.
- [6] F. Knight, "Magnetizing of permanent magnets," *Permanent Magnet Association Tech. Bull.*, vol. 7, 1966.

The Influence of Applied Tensile Stress on Power Loss in Co-Rich Amorphous Co-Fe-Si-B Ribbons with Induced Magnetic Anisotropy

H. J. V. NIELSEN, K. GYNTHNER NIELSEN, AND O. V. NIELSEN

Abstract—The influence on power loss P_T of applied tensile stress σ in amorphous $(\text{Co}_{0.89}\text{Fe}_{0.11})_{72}\text{Mo}_3\text{Si}_{15}\text{B}_{10}$ ($\lambda_s > 0$) and $\text{Co}_{73}\text{Mo}_2\text{Si}_{15}\text{B}_{10}$ ($\lambda_s < 0$) ribbons with different induced magnetic anisotropy K_u is reported. The losses are measured under sinusoidal flux conditions at $f = 50$ Hz, $J_{\text{max}} = 0.57$ T and at $f = 400$ Hz, $J_{\text{max}} = 0.10$ T. Measurements are carried out on samples in a stress-relieved state and with magnetic anisotropies induced by stress or field annealing. At $f = 50$ Hz, a minimum in P_T versus σ is observed. The σ -value (σ_{min}) corresponding to the minimum P_T increases with increasing $|K_u|$. At $f = 400$ Hz, a minimum in P_T versus σ is observed in the samples with induced magnetic anisotropy, whereas $\sigma_{\text{min}} = 0$ in the stress-relieved samples. However, no correlation between σ_{min} and K_u is possible from the present data.

INTRODUCTION

IT HAS BEEN suggested that the ac core losses of amorphous alloys could be lowered by introducing more domain walls (e.g., Shilling [1]). For crystalline Fe-Ni-Mo alloys, a minimum in eddy current losses was observed when the crys-

talline and field-induced anisotropy constants were of equal magnitude (Pfeifer [2]). It was concluded that the reason for this decrease in losses was an increase in the number of domain walls in the materials. Similarly, O'Handley and Narasimhan [3] reported lower losses for a ring-laminated core of amorphous $\text{Fe}_{40}\text{Ni}_{40}\text{B}_{20}$ alloy annealed in crossed fields (i.e., circumferential and perpendicular to the plane defined by the core) compared to cores annealed in a circumferential field only. Efforts in this direction has been reported also by Fujimori *et al.* [4], who increased the number of domain walls and decreased losses in amorphous Co-rich Fe-Co-Si-B straight ribbons by annealing in a field inclined at an angle to the ribbon axis (oblique field annealing). Annealing in a rotating magnetic field has been reported by several authors to improve initial ac permeability (and probably ac losses) in Co-rich amorphous alloys (Kohmoto *et al.* [5], Makino *et al.* [6], and Sakakima *et al.* [7]). In a recent paper [8], it was suggested to introduce two uniaxial anisotropies in the materials because the magnetic anisotropies induced by field and stress annealing of amorphous ribbons have a different origin. Field annealing of amorphous ribbons induces an easy axis in the direction of the applied magnetic field. In Co-rich amorphous ribbons, the sign of the uniaxial anisotropy induced by stress annealing depends on the sign of the magnetoelastic coupling constant λ_s and on the annealing temperature T_{ann} [9]. By proper adjustment of the stress annealing conditions, it is possible to make the ribbon axis an easy or a hard direction irrespective of the sign of λ_s .

Manuscript received May 8, 1981; revised January 6, 1982. This work was supported in part by the Danish Council for Scientific and Technical Research, Grant No. 516-20097.E-613.

H. J. V. Nielsen is with Central Telecommunications Services, Posts and Telegraphs of Denmark.

K. G. Nielsen is with the Institute for Telecommunications, Building 343, The Technical University of Denmark, DK-2800 Lyngby, Denmark.

O. V. Nielsen is with the Department of Electrophysics, Building 322, The Technical University of Denmark, DK-2800 Lyngby, Denmark.

TABLE I
THE SAMPLES AND THEIR ANNEALING TREATMENT

alloy	sp.	w mm	<t> μm	t _{ann} h	ΔT/Δt K/min.	T _{ann} °C	σ _{ann} MPa	H _{ann} kA/m	σ _{50Hz} min MPa	σ _{400Hz} min MPa	σ _u MPa	remarks
(Co _{0.89} Fe _{0.11}) ₇₂ Mo ₃ Si ₁₅ B ₁₀	A	0.42	16	1		320	500		120		-85	stress-anneal
	B	0.50	16	1		320			20	0	0	stress-relief
	C	0.45	16	1		320	150		60	25	-21	stress-anneal
	D	0.80	17		-1.6	320		440		20	-9.1	field-cool.H _⊥
Co ₇₃ Mo ₂ Si ₁₅ B ₁₀	E	0.48	18	1		250	630			18	-14	stress-anneal
	F	0.68	21		-1.6	320		2		5	-18	field-cool.H _∥
	G	0.67	21	2		325				0	0	stress-relief

We report in this paper measurements of power loss on straight ribbon samples of (Co_{0.89}Fe_{0.11})₇₂Mo₃Si₁₅B₁₀ ($\lambda_s > 0$) and Co₇₃Mo₂Si₁₅B₁₀ ($\lambda_s < 0$) metallic glasses with uniaxial magnetic anisotropies induced by field or stress annealing in such a way that the application of a tensile stress to a given sample sets up a uniaxial anisotropy of opposite sign to the one induced by the annealing treatment. Application of a tensile stress in the ribbon axis direction makes the ribbon axis an easy direction of magnetization ($K_\sigma < 0$) for $\lambda_s > 0$ and a hard direction of magnetization ($K_\sigma > 0$) for $\lambda_s < 0$.

In "wide" ($w = 13$ mm), unpolished, stress-relieved ($\frac{1}{2}$ h at 325°C in vacuum) Fe₄₀Ni₄₀P₁₄B₆ amorphous ribbons, the application of moderate tensile stresses (~ 25 MPa) results in a decrease in loss per cycle at $J_{\max} = 0.75$ T at low frequencies ($f \leq 50$ Hz) while the loss per cycle at $f = 55$ Hz is relatively insensitive to applied stresses up to ~ 25 MPa (Overshott and Blundell [10]). On the other hand, it is reported that in "narrow" ($w \sim 2$ mm), annealed ribbons of the same amorphous alloy, a reduction of power loss of 45 percent is achieved at $f = 55$ Hz, $J_{\max} = 0.75$ T for an applied stress of ~ 20 MPa (Blundell *et al.* [11]). This reduction in losses by the application of a tensile stress is to a large extent ascribed to an improvement of the static hysteresis losses. It seems that the "narrow" and "wide" ribbons respond somewhat differently to the applied stress.

EXPERIMENTAL

Amorphous ribbons (as indicated by X-ray diffraction tests) of nominal compositions (Co_{0.89}Fe_{0.11})₇₂Mo₃Si₁₅B₁₀ and Co₇₃Mo₂Si₁₅B₁₀ were prepared by a single-roller quenching technique as described in [12].

Details of the annealing treatments of the samples used in this study are given in Table I. All annealings were done in an argon atmosphere. The field and stress was applied during the entire heat treatment. In the field annealings, the samples were quickly (i.e., within 5–10 min) heated to T_{ann} and then cooled to $\sim 100^\circ\text{C}$ with the rate $\Delta T/\Delta t$. In the table, H_\perp and H_\parallel refer to fields applied perpendicular (in the ribbon plane) and parallel to the ribbon axis, respectively.

The magnitude of the induced anisotropy, described by an anisotropy constant K_u , may be determined from the static magnetization curve (ribbon axis polarization J versus applied

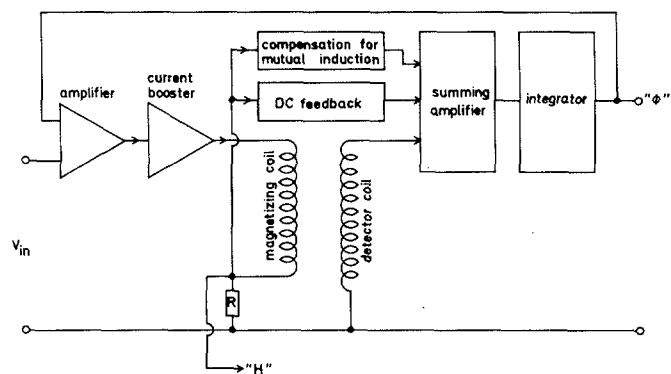

Fig. 1. Schematic diagram of the sinusoidal flux magnetizing coil system.

field H):

$$K_u = \int_0^{J_S} H dJ$$

where J_S is the saturation polarization. In our experiments, we determined K_u from the applied stress dependence of the magnetization curve, as previously described [9]. This type of measurements makes possible determinations of negative K_u values when $\lambda_s < 0$. In order to facilitate comparisons between stresses applied during the power loss measurements and induced K_u values, we calculate from K_u an equivalent induced internal stress σ_u (given in Table I) by $\sigma_u = -(2/3) K_u/\lambda_s$. We emphasize that σ_u is a pure phenomenological quantity, without indicating the physical origin of K_u .

For the power loss measurements, samples of approximately 500-mm length are magnetized in a solenoid of length 150 mm and diameter 20 mm with ~ 350 turns. The electromotive force (EMF) induced in a pickup coil of length 75 mm with ~ 9000 turns is integrated, and the magnetic polarization J versus applied field H displayed on an oscilloscope. The power loss P_T is determined from the area of the $J(H)$ loop under sinusoidal flux conditions. The flux in the sample is controlled by a feedback system shown in Fig. 1. The detector coil voltage is integrated to give a voltage proportional to the magnetic flux Φ . This voltage is compared to the control voltage V_{in} , and the difference is amplified and used to determine the magnetizing current via a current booster. To assure

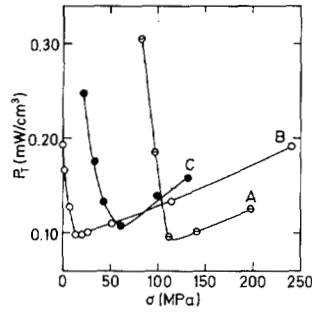

Fig. 2. Power loss P_T (mW/cm^3) versus applied tensile stress σ (MPa) at $f = 50$ Hz, $J_{\text{max}} = 0.57$ T for $(\text{Co}_{0.89}\text{Fe}_{0.11})_{72}\text{Mo}_3\text{Si}_{15}\text{B}_{10}$ amorphous ribbons with various induced magnetic anisotropies: A (\ominus): $\sigma_u = -85$ MPa, B (\circ): $\sigma_u = 0$ MPa, C (\bullet): $\sigma_u = -21$ MPa (see also Table I).

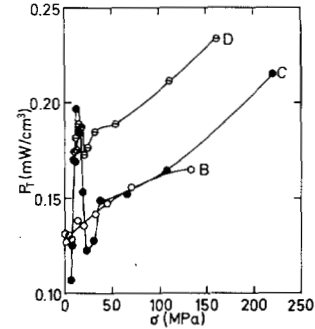

Fig. 3. Power loss P_T (mW/cm^3) versus applied tensile stress σ (MPa) at $f = 400$ Hz, $J_{\text{max}} = 0.10$ T for $(\text{Co}_{0.89}\text{Fe}_{0.11})_{72}\text{Mo}_3\text{Si}_{15}\text{B}_{10}$ amorphous ribbons with various induced magnetic anisotropies: B (\circ): $\sigma_u = 0$ MPa, C (\bullet): $\sigma_u = -21$ MPa, D (\ominus): $\sigma_u = -9.1$ MPa (see also Table I).

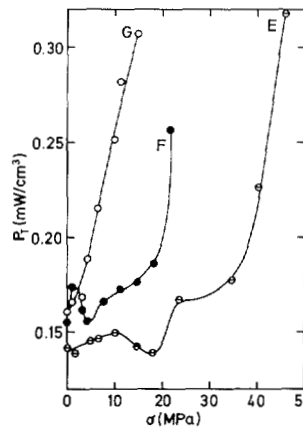

Fig. 4. Power loss P_T (mW/cm^3) versus applied tensile stress σ (MPa) at $f = 400$ Hz, $J_{\text{max}} = 0.10$ T for $\text{Co}_{73}\text{Mo}_2\text{Si}_{15}\text{B}_{10}$ amorphous ribbons with various induced magnetic anisotropies: E (\ominus): $\sigma_u = -14$ MPa, F (\bullet): $\sigma_u = -18$ MPa, G (\circ): $\sigma_u = 0$ MPa (see also Table I).

TABLE II
SOME PHYSICAL PROPERTIES OF THE ALLOYS

alloy	T_c $^{\circ}\text{C}$	T_x $^{\circ}\text{C}$	d kg/m^3	J_s T	λ_s	E MPa	ρ $\mu\Omega\text{m}$
$(\text{Co}_{0.89}\text{Fe}_{0.11})_{72}\text{Mo}_3\text{Si}_{15}\text{B}_{10}$	308	525	8390	0.75	$3.1 \cdot 10^{-6}$	$0.15 \cdot 10^6$	1.37
$\text{Co}_{73}\text{Mo}_2\text{Si}_{15}\text{B}_{10}$	293	518	8550	0.70	$-2.9 \cdot 10^{-6}$	$0.14 \cdot 10^6$	1.23

dc stability, a special dc feedback around the coils is established. Furthermore, a feedback system for compensation of the mutual induction between the coils with no sample inserted is included.

Measurements of power loss versus applied tensile stress σ were done at $f = 50$ Hz, $J_{\text{max}} = 0.57$ T on samples A, B, C (see Table I and Fig. 2) and at $f = 400$ Hz, $J_{\text{max}} = 0.10$ T on samples B, C, D, E, F, G (see Table I and Figs. 3 and 4) with applied stresses from 0–250 MPa.

The applied stress was determined from the applied load and the cross-sectional area of the sample, which in turn was determined from the weight, length, and mass density of the ribbon. The mass densities of the present alloys were calculated from values from the literature for the $(\text{Co}, \text{Fe})_{75}\text{Si}_{15}\text{B}_{10}$ system as described previously [12].

Some relevant physical properties of these alloys are given in Table II: Curie temperature T_c , crystallization temperature T_x (heating rate ~ 10 K/min), mass density d , room temperature saturation polarization J_s , magnetostriction constant λ_s , and Young's modulus E (all from [8]) and room temperature electrical resistivity ρ [12].

RESULTS AND DISCUSSION

As seen in Fig. 2, our "narrow" ($0.4 \leq w \leq 0.8$ mm) ribbons show an initial decrease in power loss with applied stress at $f = 50$ Hz, $J_{\text{max}} = 0.57$ T, as also observed by Blundell *et al.* [11]. For our alloys, the losses show a minimum and start to increase with increasing tensile stress. As seen from Fig. 2 and Table I, the stress σ_{min} corresponding to the minimum in P_T increases with increasing induced anisotropy K_u (i.e., de-

creasing σ_u), but these data do not allow further correlation of σ_{\min} to σ_u .

It could be mentioned that the P_T versus σ curve for sample *B* in the as-quenched state was nearly identical to the one shown in Fig. 2 for a stress-relieved condition; i.e., no large effect of stress relief on losses is observed for these alloys in contrast to the Fe-B and Fe-Ni-P-B alloys reported by Blundell *et al.* [11]. This may be due to the small value of the magnetoelastic coupling constant of our alloys compared to the Fe- or Fe-Ni-based alloys.

It should be emphasized that the zero field annealings, i.e., the stress relief and stress annealings, are all conducted at a temperature above the Curie temperature (see Tables I and II) so that any deterioration of low-field magnetic properties due to domain wall stabilization may be excluded (see, e.g., Fujimori *et al.* [13]).

Figs. 3 and 4 show the power loss versus applied tensile stress at $f = 400$ Hz, $J_{\max} = 0.10$ T for $(\text{Co}_{0.89}\text{Fe}_{0.11})_{72}\text{Mo}_3\text{Si}_{15}\text{B}_{10}$ and $\text{Co}_{73}\text{Mo}_2\text{Si}_{15}\text{B}_{10}$ amorphous alloys with anisotropies built in by appropriate field and stress annealings as described in the Introduction (samples *C, D, E, F* in Table I). For comparison, data for the two alloys in a stress-relieved state are included (samples *B, G* in Table I). A maximum followed by a minimum in the P_T versus σ curves is observed for the samples with preinduced anisotropies, whereas these extrema are absent in the stress-relieved-only samples.

CONCLUSION

The initial reduction in P_T versus σ at 50 Hz (Fig. 2) is thought to be due to an improvement in the static hysteresis losses [11].

The origin of the minimum in P_T versus σ at 400 Hz (Figs. 3 and 4) is thought to be a more or less complete cancellation of the lowest order terms in the expressions for the free energies of the two uniaxial anisotropies, leaving only higher order terms in the expression for the total free energy [8]. The complicated course of the curves in Figs. 3 and 4 suggests that the cancellation is not at all complete for these samples, and one might suspect that an ideal situation and thus a correlation between the preinduced and tension-induced anisotropies is very difficult to obtain.

ACKNOWLEDGMENT

The authors are grateful to Professor V. Frank for helpful discussions and a critical reading of the manuscript and to K. Pedersen for fabricating the ribbons.

REFERENCES

- [1] J. W. Shilling, "Domain structure during magnetization of an annealed and elastically strained amorphous Ni-Fe-P-B alloy," *AIP Conf. Proc.*, vol. 29, pp. 222-223, 1976.
- [2] F. Pfeifer, "On the influence of annealing in a magnetic field on binary and molybdenum alloyed nickel iron alloys containing 50 to 65 wt. % nickel," *Z. Metallkde.*, vol. 57, pp. 240-244, 1966 (in German).
- [3] R. C. O'Handley and M. C. Narasimhan, "Low-field magnetic properties of wide Fe-Ni metallic glass strips," *IEEE Trans. Magn.*, vol. MAG-15, pp. 970-972, 1979.
- [4] H. Fujimori, H. Yoshimoto, and H. Morita, "Anomalous eddy current loss in amorphous magnetic thin sheets and its improvement," *IEEE Trans. Magn.*, vol. MAG-16, pp. 1227-1229, 1980.
- [5] O. Kohmoto, H. Fujishima, and T. Ojima, "Magnetic annealing of zero magnetostrictive amorphous alloy with high saturation induction," *IEEE Trans. Magn.*, vol. MAG-16, pp. 440-443, 1980.
- [6] Y. Makino, K. Aso, S. Uedaira, M. Hayakawa, Y. Ochiai, and H. Hotai, "Induced magnetic anisotropy of Co-based amorphous alloys," *J. Appl. Phys.*, vol. 52, pp. 2477-2479, 1981.
- [7] H. Sakakima, H. Senno, Y. Yanagiuchi, and E. Hirota, "Zero magnetostrictive amorphous alloys with high permeability and high magnetic induction," *J. Appl. Phys.*, vol. 52, pp. 2480-2482, 1981.
- [8] O. V. Nielsen and H. J. V. Nielsen, "Strain- and field-induced magnetic anisotropy in metallic glasses with positive or negative λ_s ," *Solid State Commun.*, vol. 35, pp. 281-284, 1980.
- [9] —, "Magnetic anisotropy in $\text{Co}_{73}\text{Mo}_2\text{Si}_{15}\text{B}_{10}$ and $(\text{Co}_{0.89}\text{Fe}_{0.11})_{72}\text{Mo}_3\text{Si}_{15}\text{B}_{10}$ metallic glasses, induced by stress-annealing," *J. Magn. Magn. Mat.*, vol. 22, pp. 21-24, 1980.
- [10] K. J. Overshott and M. G. Blundell, "The variation of power loss and domain wall spacing with applied stress in wide amorphous ribbon material," *IEEE Trans. Magn.*, vol. MAG-16, pp. 1221-1223, 1980.
- [11] M. G. Blundell, C. D. Graham, Jr., and K. J. Overshott, "Variation of power loss of amorphous ribbon alloys with frequency and applied stress," *J. Magn. Magn. Mat.*, vol. 19, pp. 174-176, 1980.
- [12] H. J. V. Nielsen and O. V. Nielsen, "Amorphous metals with negative and positive λ_s especially suited for investigation of field- and strain-induced magnetic anisotropy," in *Proc. Conf. Metallic Glasses: Science and Technology*, Budapest, 1980, vol. II, pp. 95-100.
- [13] H. Fujimori, H. Yoshimoto, T. Masumoto, and T. Mitera, "Anomalous eddy current loss and amorphous magnetic materials with low core loss," *J. Appl. Phys.*, vol. 52, pp. 1893-1898, 1981.