

Technical University of Denmark



## Removal of Particles from the Supply Air of Ventilation Systems Avoiding the Formation of Sensory Pollution Source

Delivery of Clean Air to Building Occupants

**Bekö, Gabriel**

*Publication date:*  
2008

*Document Version*  
Publisher's PDF, also known as Version of record

[Link back to DTU Orbit](#)

*Citation (APA):*

Bekö, G. (2008). Removal of Particles from the Supply Air of Ventilation Systems Avoiding the Formation of Sensory Pollution Source: Delivery of Clean Air to Building Occupants.

**DTU Library**  
Technical Information Center of Denmark

---

### General rights

Copyright and moral rights for the publications made accessible in the public portal are retained by the authors and/or other copyright owners and it is a condition of accessing publications that users recognise and abide by the legal requirements associated with these rights.

- Users may download and print one copy of any publication from the public portal for the purpose of private study or research.
- You may not further distribute the material or use it for any profit-making activity or commercial gain
- You may freely distribute the URL identifying the publication in the public portal

If you believe that this document breaches copyright please contact us providing details, and we will remove access to the work immediately and investigate your claim.

Faculty of Civil  
Engineering

Slovak  
University of  
Technology in  
Bratislava

*and*

ICIEE  
Department of  
Mechanical  
Engineering

Technical  
University of  
Denmark  
Lyngby

# Removal of Particles from the Supply Air of Ventilation Systems Avoiding the Formation of Sensory Pollution Source

## Delivery of Clean Air to Building Occupants

Doctoral dissertation

*by*

**Gabriel Bekő**

August 2007

# Removal of Particles from the Supply Air of Ventilation Systems Avoiding the Formation of Sensory Pollution Source

Delivery of Clean Air to Building Occupants

Doctoral dissertation

*by*

Gabriel Bekő

Department of Building Services  
Faculty of Civil Engineering  
Slovak University of Technology  
Bratislava, Slovakia

*and*

International Centre for Indoor Environment and Energy  
Department of Mechanical Engineering  
Technical University of Denmark  
Lyngby, Denmark

August 2007

*Dedicated to my grandparents  
Júlianna, János, Vilmos and Erzsébet*

# Contents

<b>Acknowledgements</b> .....	iii
<b>Abstract</b> .....	iv
<b>List of publications</b> .....	vi
<b>Abbreviations</b> .....	vii
<b>Symbols</b> .....	viii
<b>List of Tables</b> .....	ix
<b>List of Figures</b> .....	x
<b>1 Introduction</b> .....	1
<b>2 Background – State of the art</b> .....	3
2.1 Particles in indoor air .....	3
2.2 Health effects of particles .....	4
2.3 Purpose of air filtration .....	6
2.4 Mechanical particle filters .....	7
2.5 Ventilation filters as sources of pollution .....	10
2.5.1 Sensory pollution from ventilation filters .....	10
2.5.2 Microorganisms on ventilation filters .....	12
2.5.3 Chemistry on surfaces of used filters .....	13
<b>3 Aims, objectives and approach</b> .....	17
3.1 Initial studies of oxidation processes on filter surfaces and their impact on perceived air quality .....	17
3.2 Further studies of oxidation processes on filter surfaces: Evidence for oxidation products and the influence of time in service.....	18
3.3 Is the use of particle filtration justified? Costs and benefits of filtration with regard to health effects, building cleaning and occupant productivity .....	19
3.4 Sensory pollution from bag filters, carbon filters and combinations .....	19
3.5 Factors affecting the accuracy of measuring the pressure drop over ventilation filters .....	19
<b>4 Methods, results, discussions, conclusions – publications</b> .....	20
4.1 Initial studies of oxidation processes on filter surfaces and their impact on perceived air quality (Paper 1).....	21
4.2 Further studies of oxidation processes on filter surfaces: Evidence for oxidation products and the influence of time in service (Paper 2).....	37
4.3 Is the use of particle filtration justified? Costs and benefits of filtration with regard to health effects, building cleaning and occupant productivity (Paper 3).....	53
4.4 Sensory pollution from bag filters, carbon filters and combinations (Paper 4).....	74
4.5 Factors affecting the accuracy of measuring the pressure drop over ventilation filters (Paper 5).....	91

<b>5 Overall conclusions and recommendations</b> .....	102
5.1 Conclusions .....	102
5.2 Recommendations for future research .....	104
5.3 Recommendations for practice .....	105
<b>References</b> .....	107

## Acknowledgements

This work is the result of a collaborative doctoral study carried out at the Department of Building Services, Faculty of Civil Engineering, Slovak University of Technology and at the International Centre for Indoor Environment and Energy, Department of Mechanical Engineering, Technical University of Denmark. The study was conducted from October 2004 till August 2007.

I would like to express my gratitude to the following persons, without whom this accomplishment would not have been reachable.

Most importantly, I truly thank to my parents and the rest of my family for their all-time patience, support, believing in what I'm doing and for their open hearts and arms at every time, regardless of whether I came home daily from near or rarely from far.

My sincere thanks are due to my supervisors: Professor Dušan Petráš<sup>1</sup>, who has been always very supportive of my ideas and long-lasting visits at the Technical University of Denmark; Associate Professor Geo Clausen<sup>2</sup>, who has perfectly fulfilled the role of an unbelievable scientific advisor and Professor Charles Weschler<sup>23</sup>, who has greatly shaped me with his incredible enthusiasm, constant availability, inspiring guidance and both scientific and personal support throughout the years.

I deeply thank to late Professor P. Ole Fanger for providing me with the very first opportunity several years ago to become part of his high quality research group and for showing a fantastic example of a top-class social and scientific behavior.

I'd like to appreciate the highly valuable ideas and comments received from Professors Kirk Smith and William Nazaroff both from University of California, Berkeley. Special thanks belong to Associate Professors Fang Lei and Jørn Toftum for their constructive comments during the preparation of the experiments. I thank Oto Halás, Gyöngyi Tamás and all those who have assisted with the practicalities regarding the execution of the experiments and the associated analyses.

I express my warm thanks to the many international friends all over, from the Americas to Asia, for their never-failing support and the enrichment of my everyday life throughout the years. Special thanks are sent to Jakub Kolařík and Ján Babiak for all the moments of laughter and childishness and for staying close when our discussions moved far away from science.

A PhD scholarship has been granted by the Slovak University of Technology. The experimental part of this work has been supported by Camfil Farr and by the Danish Technical Research Council as part of the research program of the International Centre for Indoor Environment and Energy established at the Technical University of Denmark for the period 1998-2007. I would like to express my gratitude to the staff of the International Centre for Indoor Environment and Energy for the generous financial support regarding my frequent and extensive stays in Denmark and my travels to several international conferences.

Bratislava, August 2007

Gabriel Bekő

---

<sup>1</sup> Faculty of Civil Engineering, Slovak University of Technology

<sup>2</sup> ICIEE, Department of Mechanical Engineering, Technical University of Denmark

<sup>3</sup> EOHSI, UMDNJ-Robert Wood Johnson Medical School & Rutgers University, New Jersey, USA

## Abstract

Used ventilation filters can act as sources of strong sensory pollution. The pollutants emitted from loaded particle filters may include irritating products of chemical reactions occurring on the filter surfaces. Most likely oxidation reactions, especially those driven by ozone, seem to play an important role. Sensory pollutants emitted from used filters can have significant adverse impact on occupant performance. Therefore, removal of particles from the supply air of ventilation systems without the subsequent emission of pollutants into the airstream seems to be essential. Correct maintenance of filter banks, including filter replacement in due time, is also important.

The aim of this work was to gain more knowledge leading to a better understanding and solving a long recognized indoor environmental problem. The thesis deals with three core areas. Firstly, experiments were conducted to obtain better insight into the chemical processes occurring on the surfaces of used ventilation filters. Secondly, an economic evaluation was made to determine the impact of decreased occupant productivity caused by pollution from used filters on the overall costs and economic benefits associated with filtration. Finally, an experiment was designed to test the effect of different particle filters, activated carbon filters and their combinations on the perceived air quality after several months of continuous use. A commercially available HVAC filter that has low emissions of pollutants, even after substantial time in service, would mean a step forward towards finding an engineering solution to the problem. Additional measurements examined the effect of different pressure sensing techniques and several modifications of an air handling unit on the accuracy of the measurements of pressure drop over ventilation filters.

Used and new filters were found to initially remove large amounts of ozone from the air that passed through. The initial ozone removal efficiency (~50%) decreased within an hour to a low and constant value (<15%). Exposure of the filter samples to different static environments promoted the regeneration of their ozone removal capabilities. The ozone removal by used filters is assumed to occur in the first place due to chemical reactions between ozone and the organics associated with the particles captured on the filter surfaces. The ratio of submicron particle concentrations downstream of the filter to the concentrations upstream of the filter was higher when ozone was added to the airstream through the filter sample. Such a result is an underlying evidence for the generation of low volatility oxidation products on filter surfaces at the presence of ozone. Results of sensory assessments support the assumption that oxidation processes on filter surfaces contribute to the sensory pollution downstream of used filters.

The estimates of costs and the corresponding monetary benefits of particle filtration indicated that using particle filtration can lead to substantial reductions of costs in connection with occupants' mortality and morbidity, building cleaning and cleaning of HVAC systems. Although the cost-benefit ratio depends on the perspective of the stakeholder, the savings attributable to filtration would always exceed the direct costs. However, the present study showed that economic losses resulting from even a small decrease in productivity as a consequence of sensory pollutants emitted from used ventilation filters have the potential to substantially overwhelm the annual benefits of filtration.

The quality of air passing through various filter combinations was perceived most acceptable when an activated carbon filter was placed downstream of the particle filter during its 5 months long service time. A stand-alone fiberglass bag filter that incorporated activated



carbon achieved similar results at negligible increase in pressure drop during the time in service. Moreover, this filter was found to remove considerable amount of ozone from the supply air, which is beneficial from the perspective of occupants' health.

For correct maintenance of ventilation systems and filters within, accurate determination of filter pressure drops is important. The results of the experiments indicate that bends or dampers directly upstream of the filter housing, the type of pressure sensing device as well as the location of the up- and downstream static pressure sensors may significantly influence the accuracy of the pressure drop measured across ventilation filters.

## List of publications

The thesis is based on the following publications in peer-reviewed journals:

### Paper 1

**Initial studies of oxidation processes on filter surfaces and their impact on perceived air quality**

Bekö, G., Halás, O., Clausen, G., Weschler, C.J.  
*Indoor Air*, 2006, **16**, 56-64.

### Paper 2

**Further studies of oxidation processes on filter surfaces: evidence for oxidation products and the influence of time in service**

Bekö, G., Clausen, G., Weschler, C.J.  
*Atmospheric Environment*, 2007, **41**, 5202-5212.

### Paper 3

**Is the use of particle air filtration justified? Costs and benefits of filtration with regard to health effects, building cleaning and occupant productivity**

Bekö, G., Clausen, G., Weschler, C.J.  
*Building and Environment*, submitted on 28 February, 2007.

### Paper 4

**Sensory pollution from bag filters, carbon filters and combinations**

Bekö, G., Clausen, G., Weschler, C.J.  
*Indoor Air*, submitted on 30 May, 2007.

### Paper 5

**Factors affecting the accuracy of measuring the pressure drop over ventilation filters**

Bekö, G.  
*The International Journal of Ventilation*, submitted on 30 May, 2007.

## Abbreviations

AC	activated carbon
ASHRAE	American Society of Heating, Refrigerating, and Air Conditioning Engineers
CADR	clean air delivery rate
CAFÉ	Clean Air For Europe
CDC	Centers for Disease Control and Prevention
COI	cost of illness
C-R	concentration – response
EPA	Environmental Protection Agency
ER	emergency room
ETS	environmental tobacco smoke
FISIAQ	Finnish Society of Indoor Air Quality and Climate
HCL	human capital loss
HEPA	high efficiency particulate air
HVAC	heating, ventilation and air conditioning
IAQ	indoor air quality
MERV	minimum-efficiency reporting value
MRAD	minor restricted activity days
PAH	polycyclic aromatic hydrocarbons
PM2.5 (PM10)	particulate matter with a diameter less than 2.5µm (10µm)
RH	relative humidity
SBS	sick building syndrome
SOA	secondary organic aerosols
SVOC	semi-volatile organic compounds
TSP	total suspended particles
ULPA	ultra low penetration air
VOC	volatile organic compounds
VSLY	value of statistical life-years
WHO	World Health Organization
WLD	work loss days
WTP	willingness to pay
YLL	year of life lost

## Symbols

<b>Symbol</b>	<b>Meaning</b>	<b>Unit</b>
$A_m$	Filter arrestance	[%]
$A_{avg}$	Average filter arrestance	[%]
$D_i$	Ozone concentration downstream of a filter for the given time step	[ppb]
$E_i$	Filter's ozone removal efficiency for a given time step	[%]
$E_m$	Average particle collection efficiency of a filter	[%]
$E_1, E_2, E_3$	Average particle collection efficiency of a filter for various size-ranges	[%]
$E_0$	Ozone removal efficiency of a filter at the beginning of the measurement series	[%]
$E_{60}$	Ozone removal efficiency of a filter 60 minutes after the start of the measurement series	[%]
$E_\infty$	Ozone removal efficiency of a filter at the end of the measurement series	[%]
$q$	Airflow rate	[m <sup>3</sup> /s]
$R_i$	Amount of ozone removed from the air stream by a filter during a given time step	[μg]
SD	Standard deviation	[-]
$U_i$	Ozone concentration upstream of a filter for a given time step	[ppb]

# List of Tables

## 2.1 Particles in indoor air

*Table 1.* Size ranges of common indoor particles..... 4

## 2.4 Mechanical particle filters

*Table 2.* Filter classification in accordance with EN 779 (2002) and Eurovent 4/9 (1996)..... 8

*Table 3.* Filter classification by ASHRAE 52.2 (1999)..... 9

## 4.1 Initial studies of oxidation processes on filter surfaces and their impact on perceived air quality (Paper 1)

*Table 1.* Ozone removal efficiencies of the nine filter samples at the beginning ( $E_0$ ) and end ( $E_\infty$ ) of the measurement series both before and after filter treatment; samples 7-9 had been ventilated for 24 hours before the initial evaluation.....30

*Table 2.* Ozone consumptions for the nine filter samples at 10, 30 and 50 minutes during initial and subsequent measurement series; samples 7-9 had been ventilated for 24 hours before the initial evaluation..... 30

*Table 3.* Ozone removal efficiencies and ozone consumptions for a new filter at two different airflows.....30

## 4.2 Further studies of oxidation processes on filter surfaces: Evidence for oxidation products and the influence of time in service (Paper 2)

*Table 1.* Experimental conditions for particle concentration measurements..... 41

## 4.3 Is the use of particle filtration justified? Costs and benefits of filtration with regard to health effects, building cleaning and occupant productivity (Paper 3)

*Table 1.* Input data used in the analysis..... 57

*Table 2.* Annual costs of air filtration (fibrous bag-filters).....58

*Table 3.* Baseline rates, C-R functions and unit values of morbidity endpoints..... 62

*Table 4.* Input values used for the lower, central and upper estimates of endpoints associated with the use of particle filtration..... 66

## 4.4 Sensory pollution from bag filters, carbon filters and combinations (Paper 4)

*Table 1.* Filter sets evaluated for sensory pollution after ~5 months of continuous service in outdoor test plenums operated at 1300 m<sup>3</sup>/hr..... 81

*Table 2.* Weights and pressure drops for the filters prior to and after the 5-month service interval..... 82

## 4.5 Factors affecting the accuracy of measuring the pressure drop over ventilation filters (Paper 5)

*Table 1.* Pressure drop across the filter measured at five different locations at six various modifications of the ventilation unit. The pressure drop of an empty filter box is indicated in the last row of the table (system G). “Up” stands for upstream, “down” stands for downstream position of the respective unit component. The tested positions of sensors are simply described. See text and Figure 2 for details..... 97

## List of Figures

### 4.1 Initial studies of oxidation processes on filter surfaces and their impact on perceived air quality (Paper 1)

<i>Figure 1.</i> Test rig used for ozone consumption measurements.....	25
<i>Figure 2.</i> Test rig used for sensory assessments by facial exposure.....	28
<i>Figure 3.</i> Ozone removal efficiency of filter sample 6 versus time; airflow = 0.2 L s <sup>-1</sup> ; after ~120 minutes the filter was heated for 48 hours before re-evaluation.....	29
<i>Figure 4.</i> Ozone removal efficiency of filter sample 9 versus time; sample 9 had been ventilated for 24 hours before the initial evaluation; airflow = 0.2 L s <sup>-1</sup> ; after ~90 minutes the filter was heated for 24 hours before re-evaluation.....	29
<i>Figure 5.</i> Acceptability of the air downstream of the filter samples; assessments (facial exposure) before, immediately after and 2 hours after treatment. The mean values and the 95% confidence intervals are shown.....	31

### 4.2 Further studies of oxidation processes on filter surfaces: Evidence for oxidation products and the influence of time in service (Paper 2)

<i>Figure 1.</i> Small-scale test rig used for the particle measurements.....	41
<i>Figure 2.</i> Small-scale test rig used for the ozone measurements.....	42
<i>Figure 3.</i> A leg of the small-scale manifold used for loading filter samples with outdoor air from which ozone had been removed by titration with nitric oxide (NO). An analogous leg, but without the NO titration, was used for loading filter samples with outdoor air that contained naturally occurring ozone.....	43
<i>Figure 4.</i> Particle concentrations (0.02 – 1 µm diameter) upstream and downstream of a filter sample ventilated with ozone-free air (Experiment 1) and of a different sample of the same filter ventilated with air containing ozone (Experiment 2). The corresponding ozone removal efficiency (Experiment 2) is shown.....	45
<i>Figure 5.</i> Ratios of particle concentrations (Downstream/Upstream) for Experiments 1 to 8 in Table 1. Standard deviations are indicated in parentheses.....	45
<i>Figure 6.</i> Ozone removal efficiencies versus time in service for filter samples taken from the air-handling unit of an office building in a suburb of Copenhagen, Denmark. Initial measurements (solid diamonds, E <sub>0</sub> ) and measurements made at 60 minutes (open squares, E <sub>60</sub> ) are shown.....	46
<i>Figure 7.</i> Ozone removal efficiencies of an untreated and two differently ventilated new filter samples. After the initial measurement series the untreated filter sample was statically exposed to nitrogen for 48 h before re-evaluation. Initial measurements (E <sub>0</sub> ) and measurements made at 60 minutes (E <sub>60</sub> ) are shown.....	47
<i>Figure 8.</i> Ozone removal efficiencies of the two 9-weeks-of-service filter samples, one soiled with ambient air containing ozone and the other simultaneously soiled with the same ambient air from which ozone had been removed (see text for details). Initial measurements (E <sub>0</sub> ), and measurements made at 60 minutes (E <sub>60</sub> ) and at the end (E <sub>∞</sub> ) of the evaluations are shown.....	47

### **4.3 Is the use of particle filtration justified? Costs and benefits of filtration with regard to health effects, building cleaning and occupant productivity (Paper 3)**

<i>Figure 1.</i> Economic benefits derived from decreased mortality rates as a function of average indoor PM10 concentration reduction with filtration. Benefits are depicted for scenarios that assume indoor PM10 concentration without filtration to be 65%, 80% or 95% of the outdoor PM level. The results determined using a) human capital losses and b) value of statistical life year are shown.....	61
<i>Figure 2.</i> Economic benefits from decreased morbidity rates as a function of average indoor PM10 concentration reduction with filtration. Benefits are depicted for scenarios that assume indoor PM10 concentration without filtration to be 65%, 80% or 95% of the outdoor PM level. Results are shown for decreased rates of a) minor restricted activity days (MRAD), b) work loss days (WLD) and c) total morbidity.....	62-63
<i>Figure 3.</i> Economic benefits as a function of decrease of cleaning costs due to particle filtration. The correlation is shown for scenarios that assume \$5, \$10, \$15 or \$20 /m <sup>2</sup> per year cleaning cost when no filtration is used.....	64
<i>Figure 4.</i> Monetary loss as a function of productivity loss due to pollutants from used ventilation filters. The correlation is depicted for three different scenarios: decreased occupant productivity occurs over 33, 50 or 75% of the filter's service-life.....	66
<i>Figure 5.</i> Lower, central and upper estimates of the aggregated benefits and costs of particle filtration from four perspectives: a) building owner, b) employer, c) employer/ building owner and d) society (see text for details).....	67-68

### **4.4 Sensory pollution from bag filters, carbon filters and combinations (Paper 4)**

<i>Figure 1.</i> Test plenum configuration used for soiling and testing several filter types, either alone or in combinations. The number of filter boxes within each unit was based on the number of filters in a given filter set.....	79
<i>Figure 2.</i> Scheme for one of the test plenums installed in the field labs during the sensory assessments. The three test plenums contained different number of filter boxes so that all filter sets could be evaluated.....	80
<i>Figure 3.</i> Acceptability of air downstream of the new and used filters or filter combinations. Mean assessed values and 95% confidence intervals are shown. The solid line depicts the mean acceptability assessed for air that had passed through the three empty test plenums. See Table 1 for key to x-axis labels.....	83

### **4.5 Factors affecting the accuracy of measuring the pressure drop over ventilation filters (Paper 5)**

<i>Figure 1.</i> Ground view of the ventilation unit used for measurements of the filter's pressure drop. System A, shown here, was used for the initial set of measurements before the unit was modified.....	94
<i>Figure 2.</i> Tested positions of the upstream and downstream static pressure sensors.....	95
<i>Figure 3.</i> Perforated probe used for measuring static pressure upstream and downstream of the filter.....	95
<i>Figure 4.</i> Five modifications (B through F) of the ventilation unit used for the measurements of pressure drop across a ventilation filter.....	96

# 1 Introduction

The World Health Organization (WHO) states under the principle of the human right to health, that everyone has the right to breathe healthy indoor air (WHO, 2000). Health is the state of complete well-being, and not only the absence of disease. Healthy indoor air is thus air that does not cause diseases and ensures well-being for occupants. However, it is generally accepted that indoor air is more polluted than outdoor air, often even in highly polluted industrial cities (US EPA, 1995). Moreover, people in developed countries spend most of their time indoors. Thus the risks to health may be greater due to exposure to air pollution indoors than outdoors. Indoor air quality (IAQ) seems to be an important determinant of population health and wellbeing (Sundell, 1999).

Studies all over the world have documented that high portion of building occupants consider the indoor air quality unacceptable and suffer from Sick Building Syndrome (SBS) symptoms. The prevalence of asthma and allergic diseases has increased during the past decades, most likely due to changes in environmental exposure (see Sundell, 2004 and references therein). The control of indoor air quality is often inadequate in spite of its significant role in determining health. Mechanical ventilation systems are nowadays common to ensure that ventilation standards and guidelines are met. Paradoxically, studies have found that people in mechanically ventilated buildings are less satisfied with the environment than in naturally ventilated buildings (Burge et al., 1987; Skov and Valbjørn, 1987; Mendell and Smith, 1990). Consequently, poor air quality can negatively affect occupants' productivity (Wargocki et al., 1999, 2000a).

Many of the particles either generated indoors or entering the buildings from outdoors can trigger allergic reactions, asthma and lower respiratory symptoms (Committee on Health Effects of Indoor Allergens, 1993). Epidemiological studies report close association between outdoor airborne particles and mortality and morbidity (Dockery et al., 1993; Pope et al., 1995, 2002; Dominici et al., 2006). Particles and other pollutants may enter the buildings through the ventilation system. Therefore, the importance of air filtration is being more and more acknowledged (Fisk et al., 2002; Fisk and Rosenfeld, 1997). Supply air filters are important components of ventilation systems, not only to prevent air-handling units from becoming dirty but also to protect occupants and provide good air quality.

For these reasons, more efficient filtration units are being developed. In addition to increased efficiency, minimizing the pressure drop and energy costs are the aims of further development. However, new filtration systems are often expensive compared to traditional ones and other disadvantages have to be solved as well. Traditional fiber filters are the most preferred in practice for their best balance between costs and performance. On the other hand, commonly used bag-type fiber filters can act as significant sources of indoor air pollution (Hujanen, 1991; Bluysen, 1993; Pejtersen, 1996; Gholami et al., 1997; Pasanen et al., 1994; Pasanen, 1998; Hyttinen et al., 2001, 2007a) with consequent impact on perceived air quality, sick building syndrome symptoms (Clausen et al., 2002b) and performance (Wargocki et al., 2004a). This can result from neglected maintenance of HVAC systems and insufficiently frequent filter replacement, which is often the case.

Filters are at the interface between outdoor and indoor air. The amount of particles on the surface of the filter increases by time. The collected particles contribute to the filter efficiency. However, they may likely become sites available for intensive surface chemistry, which needs to be further studied. The collected particles are associated with various organic compounds (Weschler, 2003b). Given a certain time, the filter becomes a huge reservoir of particulates and organics sorbed on/in them. Processes occurring on surfaces of used filters may contribute to the sensory pollution emanated from loaded ventilation filters (Weschler,



2004). Future work should confirm the association between chemistry occurring on filter surfaces and sensory pollution from used filters.

These contradictions should motivate manufacturers and researchers to develop new, low-polluting filtration techniques and improve the existing ones. One possible solution could be to completely remove the particles from the supply air stream and thus avoid accumulation of particulate matter in the air stream and the subsequent formation of sensory pollution source (see Clausen, 2004). Such a future engineering solution should, however, satisfy several important factors at the highest possible level. The main requirements are high collection efficiency, low sensory pollution, simple maintenance, low life cycle cost (mainly energy cost) and reasonable price.

Until such a product remains undeveloped, temporary solutions to the negative impact of used particle filters could be achieved by more frequent filter replacement, by removal of particles collected on the filter surface or by preventing chemical reactions on filter surfaces to occur. Whether some of these solutions are technically possible or economically viable, has scarcely been investigated. Furthermore, various commercially available filter types and their combinations (e.g. pre-filters, fine filters, activated carbon filters) may have different effects on indoor air quality (see Pasanen et al., 1994; Pasanen, 1998; Hyttinen et al., 2001, 2007a; Mysen et al., 2006). These differences, however, need to be better determined.

Poor indoor air quality costs the United States tens of billions of dollars annually in lost productivity and medical care (US EPA, 1997a). It is not known with certainty to what extent ventilation filters can affect these outcomes. While their potential to remove particles from the supply air is highly beneficial, the processes occurring on surfaces of used filters and their adverse impact on the environmental quality are not fully understood at the present. Further research should lead towards more complex understanding of the problem from both scientific and practical point of view. The following work intends to improve our knowledge within this widely recognized area. It is anticipated to contribute to earlier scientific work which aims to overcome a specific indoor environmental problem. This work is hence expected to facilitate the improvement of indoor air quality which has such a significant influence on health, comfort and well-being of humans nowadays.

## 2 Background – state of the art

### 2.1 Particles in indoor air

Ambient air contains particles of various sizes and nature. Some of the processes and mechanisms that form particles, include condensation of vapors (small liquid particles), combustion processes (small liquid and solid particles), resuspension (larger solid particles) or spraying (small and medium liquid particles). Particles in the environment can be characterized through a number of parameters, such as size, shape, number concentration, mass concentration, solubility, reactivity, toxicity, allergenicity, etc. Most often the aerodynamic particle size is used to characterize the particles. Particle size can range from a few nanometers to tens and hundreds of micrometers. Particles in the size range below  $0.1\mu\text{m}$  are referred to as ultrafine particles. Those with size between  $0.1$  and  $2.5\mu\text{m}$  are called fine particles, and the ones larger than  $2.5\mu\text{m}$  are coarse particles. The particle diameter is an important factor which determines the behavior of a particle in the air or airstream (see Afshari and Gunnarsen, 2000).

The generally used identification of particle concentration in the scientific literature is associated with total suspended particles (TSP - the total mass of particles per volume of air), PM<sub>10</sub> and PM<sub>2.5</sub> (particulate matter with a diameter less than  $2.5\mu\text{m}$  and  $10\mu\text{m}$ , respectively). The air can contain both primary particles and secondary particles. Primary particles are directly introduced into the air, whereas secondary particles are formed there by chemical reactions of gaseous components.

The most common sources of outdoor airborne particles are natural processes such as wind erosion, human activities, mechanical wear of solid materials such as roads (mineral aerosols) and combustion processes, especially from diesel engines. Large proportion of outdoor particles can easily enter the indoor spaces through infiltration and especially ventilation in mechanically ventilated buildings such as offices and schools (Wallace, 1996; Riley et al., 2002; Weschler et al., 1996; Hänninen, 2005). Riley et al. (2002) modeled the indoor proportion of outdoor particles for both offices and residences. This proportion depends on ambient particle size distribution and building operational parameters and was determined for a broad particle size range. Indoor proportion of outdoor particles can be between 0.05 and 0.9. In this relation it is worth to look at the results of Jamriska et al. (2003), who has also modeled the effect of ventilation rate and air filtration on the concentration of indoor particles in mechanically ventilated buildings.

Indoor sources of particles may significantly contribute to particle concentrations found indoors (Clayton, 1993; Wallace, 1996). Such sources of indoor particles include human activities (paper handling, smoking, burning candles, use of gas stoves, office machines, etc.), biological processes of humans and animals (bioaerosols), and building services equipment, as for example combustion boilers. Bioaerosols are particles of living origin and can be produced by plants, animals and humans (Owen et al., 1992). They consist of pollen, viruses, bacteria, fungal spores, hair, dandruff and by-products. Insects, for instance spiders and house dust mites can also produce particles which can furthermore carry bacteria and viruses. Another group of particles found both in outdoor and indoor air are fibers, present in building materials, manufactured products from ceramics or glass, and textiles. In addition, cleaning activities can contribute to indoor particulate pollution (Kildesø et al., 1998; Kildesø and Schneider, 2001). Reactions between ozone and certain organic compounds such as terpenoids present in e.g. cleaning products may significantly increase the mass concentration of secondary organic aerosols (SOA) (Weschler and Shields, 1999; Nazaroff and Weschler, 2004; Weschler, 2003a and references therein, Tamás, 2005). Despite, lack of cleaning may

negatively impact indoor air quality (Franke et al., 1997). Skulberg et al. (2004) concluded that intensive cleaning in indoor environments reduces airborne dust levels and mucosal symptoms among occupants.

Another mechanism responsible for altered indoor airborne particle concentrations is resuspension of settled particles. Resuspension greatly varies with activity taking place in the space as well as with particle size. Particles smaller than 1 $\mu$ m are not likely to be resuspended whereas resuspension increases with increasing particle size (Thatcher and Layton, 1995; Schneider et al., 1994).

For the size range of some particles found indoors, see Table 1 (see also Owen et al., 1992; McDonald and Ouyang, 2001).

**Table 1.** Size ranges of common indoor particles

Particle	Diameter, $\mu$ m
Pollens	10 – 100
Spores	2 – 200
Cotton fibers	8-33 $\mu$ m x 10-27mm
Carbon black	<0.5 – 10
Bacteria	0.3 – 30
House dust mite	100 – 300
Human hair	50 – 150
Viruses	0.03 – 0.05
Asbestos	0.5
Coal dust	1 – 100
Fiberglass	8
Auto emissions	1 – 120+
Burning wood in fireplace	0.17
Fly ash	1 – 2000
Tobacco smoke	0.01 - 1
Air freshener	0.2 - 2
Diesel Soot	0.01-1
Cat dander	1-3
Skin flake	1-40
Visible dust	>25

## 2.2 Health effects of particles

Adverse health effects of particles in ambient air have been recognized by a number of studies (WHO, 2002). Several epidemiological studies (e.g., Dockery et al., 1993; Pope et al., 1995; Pope et al., 2002; Dominici et al., 2006) have reported associations between outdoor airborne particles and both morbidity and mortality. There is strong evidence that ambient air pollution is associated with respiratory symptoms, medication use, asthma and chronic obstructive pulmonary disease. Other health endpoints of acute and chronic exposures include hospital admissions, emergency room visits, restricted activity days, work loss days, etc.

Health effects resulting from particles are closely related to the size of the inhaled particles. Particles larger than 30 $\mu$ m hardly enter the nasal passages. Those in the size range of 5-10 $\mu$ m and larger deposit in the passages of the nose and pharyngeal region. Impaction is the predominant mechanism of particle deposition in this region. The tracheal bronchiolar region captures particles in the 1-5 $\mu$ m size range and that occurs mainly through gravitational settling. Particles smaller than 1 $\mu$ m tend to pass deeper in the lungs and deposit on the alveolar walls in the pulmonary region. Diffusion is the major mechanism that drives the

deposition of small particles in the lungs (Owen et al., 1992). For particle fractions with diameters smaller than either 10  $\mu\text{m}$  (PM10) or 2.5  $\mu\text{m}$  (PM2.5), it is believed that a safe concentration does not exist (Sandström et al., 2005). While earlier studies have been focusing more on the impact of PM10, recently PM2.5 data is of particular concern (US EPA, 1997b; WHO, 2005). However, studies emphasize the adverse effects of coarse particles as well (Brunekreef and Forsberg, 2005).

The health effects of particulate pollution can be expressed as a function of a measured change in concentrations. The epidemiological studies derive an exposure-response relationship which estimates the relative risk of health impacts. Most studies accept linear dose-response relation, where change in exposure is proportional to the respective health effects (Cohen et al., 2004; Hänninen et al., 2005). Other studies may use log-linear functions for the exposure-response relationship.

The exposure-response functions obtained from previous studies differ from one another. Although Jerrett et al. (2005) reports up to three times larger chronic health effects associated with exposure to PM2.5 than previous studies, the 1999 U.S. EPA Report to Congress on the Benefits and Costs of the Clean Air Act 1990 to 2010 (US EPA, 1999) and other authors prefer to use the results of the American Cancer Society study (Pope et al., 1995). This work, executed within a large geographic area, concludes a 6.6% increase in mortality rates for a  $10\mu\text{g}/\text{m}^3$  increase of PM2.5. This is equivalent to 3.5 - 3.8% increase in mortality rates for each  $10\mu\text{g}/\text{m}^3$  increase of PM10 (Cifuentes et al., 2001, Cesar et al., 2002). The derivation of the later value strongly depends on the ratio of PM2.5 to PM10.

Due to the fact that we spend most of our time indoors, most of the exposure to particles occurs inside buildings. Schneider et al. (2003) concluded that there is insufficient scientific evidence that indoor airborne particle mass or number concentration could be used as an indicator of health effects. This meta-analysis however excluded studies specifically addressing environmental tobacco smoke (ETS), house dust mites, animal allergens, microorganisms or pesticides. Indoor generated particles, such as ETS can be associated with lung cancer, heart diseases and other health effects (US EPA, 1992). Droplet nuclei from people's coughs and sneezes can cause infectious diseases and common colds (Couch, 1981). Additionally, pollens, fungal spores and other allergens entering the indoor environment from outdoors may trigger symptoms of allergies and asthma, the prevalence of which is rapidly increasing (see Sundell, 2004 and references therein).

An important characteristic of particles from the health point of view is their toxic effect. Certain particles do not need to reach deeply in the respiratory track in order to render an impact. For example, large pollen particles may cause allergic effect already in the upper airways. Other particles may contain inflammatory agents (Milton, 1996) and transport them into the lung (Laskin et al., 2003). Endotoxin, for instance, was shown to mediate proinflammatory responses for both indoor and outdoor particles. The presence of other proinflammatory components of fine particles, particularly in indoor-generated particles, was suggested by Long et al. (2001). The study estimated that indoor-generated particles may be more bioactive than ambient particles. Holgate (2003) and Gong et al. (2003) found very small effect of exposure to concentrated ambient particles on pulmonary function, blood parameters and other inflammatory markers in healthy and asthmatic subjects. After exposure to diesel particles, the lung function changed moderately in both healthy subjects and those with asthma. Healthy participants showed changes in some markers of inflammation but subjects with asthma did not.

## 2.3 Purpose of air filtration

Air filters in buildings are used to remove particles from the outdoor air supplied to the building by air handling units, and from indoor air recirculated by these systems. The main reason of using air filtration in the past was the protection of air handling components. Reduced accumulation of particles in heating, ventilation and air-conditioning (HVAC) systems may prevent equipment malfunctioning, decreased airflow rates, increased system pressure drops, restrained heat transfer (changes in energy efficiency of heat exchangers) and increased probability of fire hazards (McDonald and Ouyang, 2001). Additionally, as using supply air filters has been shown effective in protecting the indoor space from particulate pollution (Jamriska et al., 2003, Riley et al., 2002), deterioration of cultural and historic materials (Pavlogeorgatos, 2003) as well as discoloration and visible dusting of surfaces can be avoided. Filtration may thus result in decreased costs for building cleaning. It also decreases the dust accumulation in the ventilation system which leads to less frequent cleaning of the ducts and HVAC units (Pasanen, 1998). Improved particle filtration can also be effective in terms of reduced accidental risks such as short circuits in electrical devices and failures in telephone switching and computing equipment (Weschler, 1991).

Within the last decades, the potential benefits to health have been recognized as the primary purpose of filtration (Fisk et al., 2002). Enhanced filtration was associated with improvements regarding sick building syndrome (SBS) symptoms (Mendell et al., 1999). The benefits of occupants' exposure to lower indoor levels of outdoor originated particles include reduced mortality due to chronic exposure, reduced morbidity and other human health and welfare effects (Hänninen, 2005). Fisk et al. (2002) estimated 20-80% reduction in cat and dust-mite allergen concentrations, depending on filtration efficiency and airflow rate through the filter. The same study concluded that up to 80% decrease in indoor concentrations of ETS and outdoor fine-mode particles is achievable with filters of common efficiencies. The benefits of filtration can be easily translated into economic savings which outbalance the costs of filtration. Fisk and Rosenfeld (1997) examined the potentials of improved filtration to reduce transmission of diseases, allergies, asthma, sick building symptoms and loss of occupant productivity. According to the authors, when the filtration system in an office building is upgraded with more efficient filters, the financial benefits from improved indoor environment may exceed the costs of filtration by a factor of up to 18.

Another reason to use effective air filtration can be the presence of gaseous pollutants in the supply air. Molecular pollution which enters the body via breathing may even penetrate into the bloodstream and impact human comfort and health. These compounds include carbon dioxide (CO<sub>2</sub>), carbon monoxide (CO), nitric oxides (NO<sub>x</sub>), sulfur dioxide (SO<sub>2</sub>), ozone, organic compounds, etc. They are generated through various processes and activities such as traffic, combustion, cooking or printing. They can be also emitted from building materials, humans or cleaning products. Organic compounds represent a large group of chemicals which often negatively impact the quality of air (Tucker, 2001). They are referred to as VOC - volatile organic compounds. Based on their volatility, organics can be volatile, very volatile or semi-volatile (WHO, 1989). Some of them are odorous compounds or strong sensory irritants (aldehydes, styrene, etc.), others can be carcinogenic (PAH – polycyclic aromatic hydrocarbons). VOCs can be either adsorbed on surfaces of particles, or absorbed into the particles. These ones can be removed from the air by particle filters. Organics, however, can also exist in the gas phase (Weschler, 2003b), while the removal of those requires molecular filters. Molecular filters contain adsorbents with very large effective area (Underhill, 2001). The most widely used adsorbents are activated carbon, silica gel and zeolites.

## 2.4 Mechanical particle filters

Mechanical filters are those which collect particles from the air passing through them by the means of mechanical processes. Such mechanisms include straining, inertial impaction, interception and diffusion (Hinds, 1999). Electrostatic forces are not included among the processes contributing to the functioning of mechanical filters. The most commonly used method for removal of particles from supply air in HVAC units is the use of fibrous filters. Fibrous filters can be made of cellulose fibers, glass fibers or synthetic fibers. Plastic or polymer fibers are also emerging on the market. They are stronger than glass fibers, however, some of the adhesion agents used to bind the fibers together and thus improve the collection efficiency, can be emitted from these filters. Based on the construction of the filter and its media, several types of fibrous filters can be manufactured. The commonly used types include flat-panel filters, pleated media panel filters and bag filters, which are often referred to as pocket filters.

The major markers of filter performance are efficiency (percentage of airborne particulates that the filter removes), dust-holding capacity (amount of dust the filter removes before being changed), and pressure drop (resistance to the airflow). These parameters depend among others on the filter device, airflow rate and face velocity of air passing through the filter and also on the characteristics of the particles. Filters are generally least efficient at particle diameters of around 0.3  $\mu\text{m}$ . This particle size is also called the “most penetrating particle size” (Lee and Liu, 1980). Dust-loading on the filters results in increased filtration efficiency and increased pressure drop (Hanley et al., 1994).

Clean air delivery rate (CADR) is a common parameter for comparing air cleaning devices. The clean air delivery rate is defined as the airflow rate multiplied by the filter’s collection efficiency for a specific material or particle size (McDonald and Ouyang, 2001). Air filters should be designed to maximize the clean air delivery rate rather than operate at very high collection efficiencies but relatively high pressure drops. A filter that is sufficiently thick to have extremely high collection efficiency is undesirable for indoor use. The electrical energy associated with high pressure drop can be rather utilized to increase airflow through a thinner filter and thus increase CADR (Rudnick, 2004).

Several standards are available for the evaluation of air filters to be applied in HVAC systems. The American standard ASHRAE 52.1 (1992) provides the following three filter evaluation criteria, besides resistance to airflow:

*Dust spot efficiency* is a measure of a filter’s ability to remove atmospheric dust from test air and is expressed in percent. Filter efficiency is determined by comparing the discoloration of two targets, one sampling atmospheric air upstream of the tested filter and the other one sampling on the downstream side of the filter. The difference in discoloration of the target samples is determined by comparing the light transmission capability of the two sample media.

*Arrestance* is a gravimetric measure of the ability of a tested filter to remove test dust from the test air. The value is also expressed as a percent. Arrestance test is primarily used for relatively low-efficiency filters.

*Dust-holding capacity* is the quantity of synthetic test dust held by the test filter at the termination of the test. This is expressed in grams. The test is terminated when the maximum pressure drop is reached or the arrestance decreases by a specified value.

Another American standard (ASHRAE 52.2, 1999) helps to determine the filter’s initial efficiency as a function of particle size, while 12 different particle size ranges are used

between 0.3 and 10 $\mu$ m size range. The standard provides information that indicates how a filter performs at its lowest point of particle capture efficiency. Moreover, it includes a method to assign a numeric value to a filter, in order to characterize the efficiency and allow a user or engineer to specify or select a product. This value is called *minimum efficiency reporting value* (MERV). Additionally, the standard as well addresses the filters' resistance to airflow.

The European standard EN 779 (2002) uses two different types of dust to classify filters. Fine dust is used to measure efficiency as a function of particle size in the 0.2 - 3  $\mu$ m range. An average efficiency on 0.4  $\mu$ m particles is used for classifying fine filters. Coarse synthetic aerosol is used to obtain information about the dust-holding capacity and arrestance for coarse filters. Similar filter classification is recommended by Eurovent 4/9 (1996) which was amended by Eurovent 4/10 (2005) research paper. This paper describes a method of validating the performance of a filter system in real time. It is required due to the fact that the fractional or particle size efficiency of a filter during its real application is difficult to predict based on laboratory tests, when the conditions and parameters are controlled. Therefore the results obtained in the actual environment can significantly differ from what is measured during the laboratory tests. The classification of filters by their efficiency in accordance with various standards is presented in Tables 2 and 3.

**Table 2. Filter classification in accordance with EN 779 (2002) and Eurovent 4/9 (1996)**

Filter type	Class by EN 779	Average arrestance ( $A_m$ ) synthetic dust (%)	Average efficiency ( $E_m$ ), 0.4 $\mu$ m particles (%)	Final pressure drop (Pa)	Equivalent class by Eurovent
Coarse filters	G1	$50 \leq A_m \leq 65$		250	EU1
	G2	$65 \leq A_m \leq 80$		250	EU2
	G3	$80 \leq A_m \leq 90$		250	EU3
	G4	$90 \leq A_m$		250	EU4
Fine filters	F5		$40 \leq E_m \leq 60$	450	EU5
	F6		$60 \leq E_m \leq 80$	450	EU6
	F7		$80 \leq E_m \leq 90$	450	EU7
	F8		$90 \leq E_m \leq 95$	450	EU8
	F9		$95 \leq E_m$	450	EU9

The presented test methods and standards do not apply to high efficiency filters such as HEPA (high efficiency particulate air) and ULPA (ultra low penetration air) filters. Separate European standards have been introduced for testing of filters with efficiency higher than 98% on 0.4  $\mu$ m particles (EN 1822, 1998, 2000). As these filters are not the subject of the present study, they are not introduced in greater detail.

The European standard for the ventilation of non-residential buildings (EN 13779, 2004) defines filtration requirements in order to achieve a healthy indoor environment. The standard recommends filtration steps in order to provide a certain quality of indoor air at various categories of outdoor air quality. The outdoor air is categorized from ODA 1 (pure outdoor air) to ODA 5 (air highly polluted with particles and gases). The indoor air quality is classified from IDA 1 (high indoor air quality) to IDA 4 (low indoor air quality). The recommended filter classes are in accordance with EN 779 (2002). The standard generally recommends two-step filtration for hygienic reasons, with a F5 or F7 filter in the first step and a F7 or F9 in the second step, respectively. In case of one-step filtration, F7 filter should be used at the minimum. Filter of F5 class should be used in recirculation and exhaust systems. At highly polluted outdoor environment the use of molecular (gas) filters is recommended by

the standard in addition to the particulate filters. The recommended minimum filter efficiencies are supported by the work of Fisk et al. (2002). The authors found that low efficiency filters (ASHRAE dust spot efficiency of 45% or lower) were not effective for reducing indoor concentrations of ETS and outdoor fine-mode particles. On the other hand, increasing the filter efficiency above 85% resulted in only a small incremental decrease in indoor concentrations of these particles.

**Table 3. Filter classification by ASHRAE 52.2 (1999)**

MERV	Average particle size efficiency, (%) for size ranges ( $\mu\text{m}$ )			Average Arrestance (%)	Minimum final resistance (Pa)
	Range 1 0.3 – 1.0	Range 2 1.0 – 3.0	Range 3 3.0 – 10.0		
1	N/A	N/A	$E_3 < 20$	$A_{\text{avg}} < 65$	75
2	N/A	N/A	$E_3 < 20$	$65 \leq A_{\text{avg}} < 70$	75
3	N/A	N/A	$E_3 < 20$	$70 \leq A_{\text{avg}} < 75$	75
4	N/A	N/A	$E_3 < 20$	$75 \leq A_{\text{avg}}$	75
5	N/A	N/A	$20 \leq E_3 < 35$	N/A	150
6	N/A	N/A	$35 \leq E_3 < 50$	N/A	150
7	N/A	N/A	$50 \leq E_3 < 70$	N/A	150
8	N/A	N/A	$70 \leq E_3$	N/A	150
9	N/A	$E_2 < 50$	$85 \leq E_3$	N/A	250
10	N/A	$50 \leq E_2 < 65$	$85 \leq E_3$	N/A	250
11	N/A	$65 \leq E_2 < 80$	$85 \leq E_3$	N/A	250
12	N/A	$80 \leq E_2$	$90 \leq E_3$	N/A	250
13	$E_1 < 75$	$90 \leq E_2$	$90 \leq E_3$	N/A	350
14	$75 \leq E_1 < 85$	$90 \leq E_2$	$70 \leq E_3$	N/A	350
15	$85 \leq E_1 < 95$	$90 \leq E_2$	$90 \leq E_3$	N/A	350
16	$95 \leq E_1$	$95 \leq E_2$	$95 \leq E_3$	N/A	350

Requirements for higher energy savings have increased in the last years. Air handling systems often consume a large portion of a building's energy need. As the pressure drop of filters increases with increasing amount of collected particles, the filter can significantly contribute to the total pressure drop and energy requirement of a system (Matela, 2006; Camfil Farr, 2003). It is therefore important to choose an economically operating air filtration system which provides a compromise between efficiency and pressure drop. However, analysis of performance and costs of filtration by Fisk et al. (2002) found that the use of more efficient filtration does not always increase the costs. Moreover, even if more efficient filters have higher energy and total costs, those may be insignificant on a per occupant basis, especially relative to salaries, rent or health insurance costs. In addition, more frequent filter replacement could save energy and sometimes even decrease filtration costs.

Correct maintenance of filter banks and adequately frequent filter replacement is therefore important. The increase in the filter's pressure drop is the most widely used criterion to determine when a filter should be exchanged. This requires rather accurate determination of pressure drops over ventilation filters. However, guidelines regarding the monitoring of filter pressure losses in real heating ventilation and air-conditioning units are missing. Standards only exist for laboratory testing of air flow resistance of filtration media (ASTM, 2001).

In common practice, filters are replaced when their pressure drop increases to double or triple of the initial value (Carrier et al., 1959). Depending on, among others, the concentration of particles in the supply air that passes through the filter and the operating conditions, a filter replacement may be required every 6 to 24 months. It is being however recently recognized that pressure drop is not an adequate criterion for filter replacement, when hygienic aspects are taken into consideration. In a study by Pasanen et al. (1994) the filter pressure drop did



not correlate well with the odor emissions from the filter. The filter became a serious source of sensory pollution long before it reached the pressure drop required for filter change (see below for more details). According to EN 13779 (2004), the final pressure drop, the time period the filter has been installed and the time period the filter has been in operation should be taken into consideration when deciding about the filter's lifetime. First-step filters should be exchanged after 2000 operation hours or 1 year of being installed or at the final pressure drop, whichever is reached sooner. Second-step filters and filters in recirculation systems should be replaced after 4000 hours of operation or 2 years in service or when the final pressure drop is reached.

## **2.5 Ventilation Filters as Sources of Air Pollution**

### **2.5.1 Sensory pollution from ventilation filters**

Several studies of the prevalence of Sick Building Syndrome symptoms among office workers were conducted in both naturally and mechanically ventilated buildings in the late 1980's (Burge et al., 1987; Skov and Valbjørn, 1987; Mendell and Smith, 1990). These studies, conducted on a large sample size, found more symptoms among occupants in mechanically ventilated buildings than in naturally ventilated buildings. When sensory evaluations of air quality by a panel of human subjects were applied, the pollution load from various pollution sources in buildings was estimated. Studies concluded that the ventilation systems significantly contributed to the total sensory pollution load (Fanger et al., 1988; Thorstensen et al., 1990; Pejtersen et al., 1991). The sources of odors in eight ventilation units were studied by Pejtersen et al. (1989). The air quality upstream and downstream of each component of the HVAC units was evaluated. Used ventilation filters, rotary heat exchangers and humidifiers were found to be the elements most contributing to the deteriorated air quality downstream of the units.

Filters are at the interface between the outdoor and indoor air. As the amount of particles on the surface of the filter increases, the surface area of the collected particles increases. The mass collected on the filter over time forms the so-called "filter cake". Until the filter cake is present in the airstream, it may act as a source of pollution. Experiments carried out on new and used ventilation filters showed that the particles collected on the surface of the filter are the source of air pollution (Hujanen, 1991; Bluysen, 1993; Pejtersen, 1996; Gholami et al., 1997).

Pasanen et al. (1994) and Pasanen (1998) found evidence that the development of odor emissions from supply air filters was related to the amount, composition and size of dust accumulated on the filters. Odor emissions from coarse pre-filters were as high as from fine filters that were not protected by a pre-filter. Fine filters, which were protected from coarse particles by a pre-filter upstream, contributed to the total odor emissions very little (see also Hyttinen et al., 2001, 2007a). Pasanen (1998) in his work concluded that after a few months of operation, the odor emissions from the filters become stabilized at a level which would cause unacceptable indoor air quality for one third of the occupants. Similar results were obtained by Teijonsalo et al. (1993). The perceived air quality downstream of used filters previously in operation for 6 weeks, was equivalent to 20% of dissatisfied. According to the authors, the average filter lifetime of six months (or longer) is too long, when high quality of supply air is required.

The potential of used filters to act as important sources of indoor air pollution was also recognized by Clausen et al. (2002a) and Clausen (2004). The former study estimated the sensory pollution load of a used filter using either partial (facial) exposure of human subjects

to air upstream and downstream of a filter or full-body exposure to room air with and without a filter in the HVAC unit. The sensory pollution load determined with the whole-body exposure was about several times lower than that obtained from facial exposure. Even with the lower value, used filters were concluded to significantly contribute to deteriorated perceived air quality.

Recent studies have examined the adverse impact of indoor air pollution on performance of typical office work and the negative economic consequences (Wargoeki et al., 1999; Wargoeki et al., 2000a; Djukanovic et al., 2002). Polluting air filters can also play a role in relation to decreased office productivity. Wyon et al. (2000) conducted field experiments, where used supply air pre-filters were replaced in an office building with new ones. The intervention increased the self-estimated productivity of office workers by 5.7%. Wargoeki et al. (2004a) examined call-center operators' talk-time at two different outdoor air supply rates using supply air filters that were either new or had been in service for 6 months. The high outdoor air supply rate was 80% of the total airflow of 430 L/s ( $3.5 \text{ h}^{-1}$ ), while the low outdoor air supply rate was 8% of that. The performance of the operators was monitored by recording their average talk-time every 30 minutes. When used filters were replaced with new ones at high outdoor air supply rate, the workers' talk-time decreased by about 10%. Filter replacement had no effect on operators' performance at the low outdoor air supply rate. At increased outdoor air supply rate the performance improved when a new filter was in place, whereas it was reduced with used filters in the ventilation units.

Alm (2001) concluded that having a new filter in the ventilation unit instead of a used one had a significant positive effect on numerous perceptions, symptoms and self-estimated performance. However, this study found no significant influence of used filters on the actual performance of office work. On the other hand, the author documented a strong impact of used filters on the percentage of persons dissatisfied with the room air quality. This was investigated during a 4-hour exposure of human subjects in an experimental room with either a used or a new filter in the ventilation unit. Upon entering the room, 47% of the subjects were dissatisfied with the room air quality when a used filter was in the system, whereas only 16% when a new filter was present. No significant difference between the conditions was found after one hour of exposure. Still, dissatisfaction with room air quality may be strongly associated with reduced occupant performance. Wargoeki et al. (2000b, 2000c) have documented that productivity may decrease by 1.1-1.5% for each 10% increase in the percentage dissatisfied with air quality upon entering a space. It is however questionable to what extent the results of these studies represent average office work.

Fisk and Rosenfeld (1997) estimated that the productivity decrease caused by SBS symptoms can be between 1-4%. Negative influence of used filters on such perceptions and health-related symptoms were reported by Clausen et al. (2002b). In this experiment 30 human subjects entered the experimental office when either a new or a used filter was present in the ventilation system. The results observed with a used filter in comparison with a new filter included lower acceptability of the air quality, higher odor intensity, greater irritation in the nose, lower perceived freshness of the air, lower acceptability of the overall environmental conditions and higher perceived intensity of headache. After 1 hour of exposure the subjects still perceived the air quality and the overall environmental conditions less acceptable when a used filter was in the system. After almost 3 hours, the acceptability of the overall environmental conditions was still significantly lower with a used filter in place.

The opinion that it is possible to improve the air quality downstream of a used filter by increasing the airflow through the system has been partially disproved by Alm et al. (2000). It

was demonstrated that increasing the airflow rate through a used filter increases the source strength of the filter. Thus the acceptability of the air downstream of the used filter changes very little. Strøm-Tejse et al. (2003) repeated the measurements at larger range of airflows through the filter, including flow rates commonly used in ventilation systems. The study confirmed the proportional relationship between pollution load and airflow rate through a used filter.

Emissions of sensory pollutants from used filters are enhanced after periods when the ventilation system is not in operation, for example after weekends and nights. This was observed by Mysen et al. (2003), who compared the sensory pollution from used filter samples which were operating continuously with pollution from filter samples through which the airflow was turned off outside working hours. Immediately after the ventilation system was turned back on, the air downstream of the filter was perceived worse than the air downstream of the continuously ventilated filter. After outside air had been passed through the filters for 2 hours, no significant differences were found between the samples. To avoid the strong initial sensory pollution after switching the ventilation systems off and on, the authors recommended turning on the air handling units several hours before occupants would enter the ventilated space. Another option to decrease emissions from used filters was suggested by Mysen et al. (2006). In this study the perceived air quality downstream of a regular F7 bag filter was compared with the air quality from a similar bag filter that incorporated activated carbon. Both filters were in service for three months under identical conditions. The sensory evaluations of air quality downstream of these filters revealed that the air quality was significantly better downstream of the used carbon-containing bag filter than downstream of the used standard bag filter.

### **2.5.2 Microorganisms on ventilation filters**

Microorganisms such as bacteria or fungi can grow on filter materials when there is sufficient water and organic material (Elixmann et al., 1987a, 1987b; Kemp et al., 1995a, 1995b). Used filters constitute a large reservoir of nutrients supporting the survival of microorganisms, such as *Cladosporium*, *Aspergillus*, *Penicillium*, etc. However, relative humidity was found to be a limiting factor for fungal growth, being even more crucial than temperature (Martikainen et al., 1990; Pasanen et al., 1990). Relative humidity above 75% promotes fungal growth.

The counts of viable spores do not necessarily increase with filter loading; instead, they can be influenced by weather conditions and season (Möritz et al., 1999; Martikainen et al., 1990). On the other hand, it has been suggested that microorganisms are likely unable to survive under conditions commonly found in ventilation units. Airflow through the filter does not support the viability of these species (see Maus et al., 1996). Neumeister et al. (1996) estimated the amount of bacteria, molds and yeasts in 13-month-old filters and compared the values with actual measurements. The measured values were two to four orders of magnitude lower than the calculated value. The previous works suggest that ventilation filters capture microorganisms and thus decrease airborne spore concentrations, however, they can act as a source of fungal spores only at conditions favorable for microbial growth, which are unusual to occur on filter surfaces.

The impact of biological activities in ventilation filters on the perceived air quality downstream of filters was investigated by Pejtersen et al. (1996). In this laboratory experiment, two filters were placed in separate ventilation units and continuously operated for 18 weeks at either high or low relative humidity (80% and 40%, respectively). After the service period, low amount of microorganisms was found on both filters. The microbial

contamination of the air downstream of the filters was negligible. The perceived air quality downstream of the filter exposed to 40% relative humidity during its service time was consistent with that of the filter ventilated with air of 80% relative humidity.

Alm (2001) examined the influence of microorganisms in the filter on the perceived air quality. The study evaluated the air quality downstream of two used filters with identical service history. Subsequently, one of the filters was sterilized by nuclear radiation. Gamma radiation was applied twice and the procedure was expected to kill all microorganisms on the filter. The air downstream of the two filters was then reevaluated. Before sterilization of one of the filters, the quality of air passing through the two filters was significantly different. It is difficult to draw conclusions from this study, as the air quality downstream of both filters after sterilization of one of them was significantly better compared to the perceived air quality before sterilization. Moreover, after sterilization, there was no difference between the two filters. The author concluded that biological contamination of filters is most likely not the main reason for the deterioration of the air quality downstream of used filters. These results do not exclude the possible contribution of microorganisms to the sensory pollution from used filters. Martikainen et al. (1990) anticipated that microbial metabolites emanating from active microbes may contribute to odor emissions from used filters.

### **2.5.3 Chemistry on the surfaces of used filters**

The composition of particles collected on used filters is a mixture of organic and inorganic substances. Typically dust consists of biological particles such as pollen, microbes, soil-derived particles, inorganic salts and particles formed in combustion processes in energy production and traffic. The most abundant inorganic constituents in dust are silicon, zinc, aluminum, sodium and elemental carbon (Fransson et al., 1995). Regarding the organic compounds associated with particles on used filters, Hyttinen et al. (2001, 2002, 2007a) examined emissions from dust collected on pre-filters and fine filters by using thermodesorption technique. The main emitted compounds included alcohols, terpenes, aromatic hydrocarbons, but also aldehydes and carboxylic acids, which tend to have low odor and irritation thresholds. It was concluded that emissions of VOC from the particles may contribute to the stuffy odor caused by used filters. Moreover, chemical transformations of indoor pollutants, for instance those driven by ozone, can alter their odor and irritancy (Weschler and Shields, 1997; Weschler, 2000, 2004; Wolkoff and Nielsen, 2001; Klenø Nøjgaard et al., 2005; Tamás et al., 2006). Similar processes may be responsible for some of the sensory pollution emanating from used ventilation filters.

Organic compounds partition between the gas phase (in the air) and the condensed phase (e.g. on particles and other indoor surfaces). Organics that have a significant fraction in both phases are called semi-volatile organic compounds (SVOC). Equilibrium partitioning is a function of the organic compound's saturation vapor pressure (Weschler, 2003b). Gas-particle partitioning is most significant for organic compounds with low saturation vapor pressures ( $\sim 10^{-8}$  to  $10^{-12}$  atm). The surface area of particles captured on a 60 x 60 cm filter can be as high as 600 m<sup>2</sup> after a period of 12 months. These particles contain both absorbed and adsorbed organic compounds. The process of partitioning occurs between the airstream and the particles captured on the filter surface.

When organic compounds present on the filter surface are in equilibrium with their counterparts in the airstream through the filter, no desorption from the filter surface will occur. Thus, the organics sitting on the filter will have no adverse influence on the air quality.

The equilibrium can be perturbed by changes in temperature, relative humidity or concentration of relevant organics in the airstream. When the airstream concentration of organic compounds is no longer sufficient to support the equilibrium concentrations on the filters, the organics will desorb from the captured particles into the airstream passing through the filter.

Some of the organic compounds associated with captured particles, especially unsaturated organics such as oils, fatty acids and other substances originating from combustion or vegetation are readily oxidized. Oxygen ( $O_2$ ), hydroxyl radicals (OH), nitrate radicals ( $NO_3$ ) and ozone ( $O_3$ ) can initiate oxidation processes. In typical ventilation air,  $O_2$  and  $O_3$  are the dominant oxidants. The products of such processes are often semi-volatile organic compounds (SVOC), which can be sensory irritating. If these organics are not present in the air that passes through the filter, or their concentration in the air is not in equilibrium with their concentrations on the filter surface, they will desorb into the airstream. As a consequence, the perceived quality of air downstream of the filter may be deteriorated. It may take several hours or days to achieve equilibrium (see Won et al., 2000, 2001). When reaction products desorb at a rate slower than the rate at which further chemical reactions occur on the filter surface, used filters may become reservoirs of reaction products. This may be the case when no air flows through the filter. Desorption can then continue long after the oxidation and other processes have already terminated. However, desorption from filters and other HVAC components may be occurring at an increased rate when air flows through the system, in comparison with the static condition. Mølhave and Thorsen (1991) observed a dramatic increase of VOC concentration in the ventilated space directly after restarting the ventilation system following a period without operation. These results are consistent with the results of Mysen et al. (2003), who have demonstrated an increase in sensory pollution emitted from a used filter immediately after the airflow through the filter was restarted, in comparison with the continuously ventilated filter. Two hours later, the air quality downstream of both filters was almost identical.

Ozone initiated chemical reactions may result in the consumption of ozone by used filters. The ability of filters to remove ozone from the airstream was studied by several researchers. Hyttinen et al. (2003) examined the ozone removal capability of nine used supply air filters in the laboratory. Measurements were conducted both in the summer and in the winter, every time with a new small-scale sample taken from the same used filters. The average ozone removal of all filters was higher in the summer than in the winter. During the summer period, the temperature and relative humidity of air were higher. On average, used filters removed between 4 to 10% of ozone during a 6-9 hour interval. Field experiments, published in the same paper, revealed a reduction in ozone concentration across used filters in the range between 8 and 26%. The highest ozone removal efficiency was obtained in an HVAC unit with three-stage filtration (G3 pre-filter, F7 second filter and F8 final filter).

Hyttinen et al. (2006) studied ozone removal on new, used and sooty supply air filters. The authors found the highest ozone removal at the beginning of the tests. The removal efficiencies decreased during the first hour of the experiment, reaching a steady state value. The amount of dust captured by the filter influenced its ozone removal efficiency. The more dust was deposited on the filter the higher ozone removal efficiency was observed. Diesel soot removed ozone most effectively. Filters loaded with diesel soot removed 25-30% of ozone at steady state, which is significantly more than is the case with a dust-laden filter. The removal of  $O_3$  increased temporarily with increasing relative humidity of air. The study also concluded that the filters partially recovered their ozone removal ability during periods when

the airflow and ozone exposure were stopped. These results are in agreement with the findings of Mølhave and Thorsen (1991) and Mysen et al. (2003) (see above). The experiments of Hyttinen et al. (2006) further demonstrated different ozone removal for two new fiberglass fine filters from separate manufacturers. One new filter had an average initial ozone removal of 6%, decreasing to ~2% within one hour. The other new filter removed 19% of ozone during the first hour of exposure, while the removal was negligible 16 hours later. In regard with ozone removal by diesel-particle-loaded filters, it is worth noting the results of Metts et al. (2005) who estimated that such filters would remove only a small portion of the total ozone concentration from the air. The ozone removal capacity of fresh diesel soot particles collected on small-size (47mm) filters was found to be 5.6%. More heavily loaded filters removed more ozone. However, the ozone removal capacity of diesel soot was more than an order of magnitude below that of activated carbon.

Zhao et al. (2007) confirmed that loaded HVAC filters remove ozone from the supply air. In this study, the ozone removal efficiencies of new fiberglass filters, new synthetic filters, and used residential and commercial filters were investigated. Higher removal efficiency was again observed at the beginning of the measurements, which decreased to a steady state value. The average steady state ozone removal was found between 0 and 9% for clean filters (reached within 30 to 60 minutes), 10% for used residential filters and 41% for used commercial filters. Regeneration of ozone removal efficiency after periods of no exposure to airflow and ozone has been reconfirmed. During these experiments, however, the face velocity of air passing through the evaluated filters was significantly lower (0.004m/s) compared to typical face velocities used in commercial buildings (2 - 2.5m/s).

It is speculated that the removal of ozone by ventilation filters is mainly caused by reactions of ozone with organic compounds present on the filter surface. When used filters remove ozone from the air that passes through them, saturated and unsaturated aldehydes may be produced as products of oxidation reactions. In the study of Hyttinen et al. (2006), when air that contained ozone passed through dusty or sooty filters, formaldehyde and higher aldehydes (C<sub>5</sub>-C<sub>10</sub>) were produced. The rate of production decreased as ozone removal by the loaded filter decreased, until no formaldehyde production was detected after a few hours. During the first 70 minutes of ozone exposure, up to 11% of O<sub>3</sub> removed by a dusty F8 filter participated in the production of formaldehyde. The production of formaldehyde increased in the presence of soot. In this case, offgassing of formaldehyde and aldehydes was also observed before the exposure to O<sub>3</sub>, but increased during O<sub>3</sub> exposure.

Reactions between ozone and certain higher molecular weight unsaturated organic compounds may significantly increase the mass concentration of secondary organic aerosols (Weschler and Shields, 1997, 1999; Wainman et al., 2000; Rohr et al., 2003; Weschler et al. 2003 and references therein). Oxidation reactions occurring on filter surfaces may similarly lead to the growth of ultrafine airborne particles downstream of used ventilation filters. Hyttinen et al. (2007b) measured the ozone removal and the up- and downstream concentration of ultrafine particles on sooty ventilation filters saturated with alpha-pinene vapor, in order to examine the possible formation of secondary aerosols by heterogeneous reactions. Some particle formation was observed at the start of ozone dosing, when filters were still saturated with alpha-pinene. This observation was however not very significant and the authors concluded that formation of secondary aerosols is not practically important on supply air filters.

Ozone and other gaseous pollutants can be removed from the airstream by activated carbon

(AC) filters. Weschler et al. (1993, 1994) and Shields et al. (1999) examined the performance of several activated carbon filters over a period of 5 to 8 years. The authors found that the filter's initial efficiency of removing ozone and selected VOCs (95% and 65 - 80%, respectively) did not change after 20 months of continuous use. After 5 years of operation, a filter protected by both a pre-filter and a EU7 efficiency filter still removed 90% of ozone from the supply air. Another carbon filter, which was processing a greater volume of air per unit mass of charcoal, had an initial ozone removal efficiency of 85%. This filter was protected less efficiently from submicron particles (by a pre-filter only). No performance degradation was observed after one year of service. Its ability to remove ozone decreased to 60% after 3 years. This efficiency remained unchanged even after 8 years of service. Similarly, Shair (1981) demonstrated significant reduction of ozone concentration by activated carbon filters and estimated a minimum lifetime of three years for charcoal filters. In a recent study Zhao (2006) studied the ozone removal efficiency of a clean activated carbon filter at laboratory conditions. The experiments were carried out at a significantly smaller airflow through the filter than in real applications. A constant ozone removal efficiency of 100% was observed over five months, at an exposure to 300ppb of ozone upstream.

Lee and Davidson (1999) investigated the ozone removal efficiency of granule activated carbon filters and an activated carbon fiber filter. The initially high efficiencies rapidly decreased during a few hours of ozone exposure. The highest initial ozone removal (98%) was observed for the AC fiber filter. The study concluded that the involved chemical reactions may change the composition of the carbon and consequently decrease the removal efficiency. Changes in relative humidity, from 20 to 80%, did not influence the performance of a granule activated carbon filter. However, efficiency of the AC fiber filter decreased when relative humidity increased from 20 to 50%.

Metts and Batterman (2006) found that the removal of ozone by activated carbon filters is influenced by their previous exposure to VOC. Generally, VOC loadings provided a reduction in O<sub>3</sub> removal capacity. Toluene-loaded filters showed rapid ozone breakthrough, whereas limonene-loaded filters exhibited initially higher ozone removal, which then rapidly decreased. While non-reactive toluene was anticipated to block ozone from reaching reactive sites on the activated carbon before penetrating through the filter, limonene reacted with the ozone passing through the filter. As the readily accessible limonene molecules were depleted, limonene- and toluene-loaded samples behaved similarly.

### 3 Aims, objectives and approach

The major aims and objectives of this work are introduced below:

1. The sensory pollution from used ventilation filters is a problem in many air-conditioned buildings. The problem calls for an engineering solution. Elucidating the chemistry responsible for the poor air quality downstream of used filters and understanding its actual impact on the environmental quality might be beneficial when approaching a practical solution. As it has been pointed out in the previous chapter, several researchers have contributed to the understanding of the processes responsible for the observed effect. However, a full explanation has not been gained so far. It was therefore decided to conduct further experiments that should lead towards a better understanding of the chemical processes occurring on used filter surfaces (Papers 1 and 2).
2. Awareness of the monetary savings from avoided sensory pollution from used filters may be helpful when choosing a filtration strategy or investing into improvements of air quality. A calculation tool was developed to assess the impact of poor air quality caused by used ventilation filters on the ratio of the overall costs and economic benefits of filtration (Paper 3).
3. Finding an easily applicable way to prevent sensory pollutants emitted by used filters from entering the occupied space would mean a step forward to a practical solution of the problem. An experiment was designed to find a commercially available filter type or a combination of filters which would not have a negative impact on air quality as it becomes loaded with particles. The experiment tested the air pollution from various used particle filters, activated carbon filters and their combinations (Paper 4).
4. Another practical solution may be to replace supply air filters more frequently. The criterion used today to determine when a filter should be replaced is its final pressure drop. Accurate measurement of the pressure drop thus seems to be important for correct maintenance of filter banks. However, standards and regulations regarding the correct monitoring of filter pressure losses are missing. The accuracy of pressure drop measurements in practice has been scarcely investigated. Results of the experiments presented in this work (Paper 5) intend to provide suggestions leading to more accurate monitoring of filter pressure drops and may indirectly facilitate the proper maintenance of filter banks.

The methods used during the investigations included computational approach and laboratory experiments. The experiments were conducted in the facilities of the International Centre for Indoor Environment and Energy at the Technical University of Denmark. The core of the thesis consists of five peer-reviewed journal papers, each of them dealing with one or more individual studies. The objectives and general methods of each study are briefly presented below. Detailed description of the facilities and methods can be found in the papers themselves (see Chapter 4).

#### **3.1 Initial studies of oxidation processes on filter surfaces and their impact on perceived air quality** (Paper 1)

When ozone-containing air passes through loaded ventilation filters, a fraction of the ozone is removed by the filters. The ozone removal may be partly due to reactions of ozone with organic compounds associated with the captured particles. The oxidation products may



presumably contribute to the decreased perceived air quality. The purpose of the laboratory experiments presented in Paper 1 was to improve our understanding of ozone-initiated oxidation processes occurring on filter surfaces and the impact of these processes on the perceived air quality.

Ozone concentrations up- and downstream of used and new small-scale filter samples were monitored and the respective ozone removal efficiencies at the beginning and end of each measurement series were calculated. This was done before and after the filter samples were exposed to different static environments, in order to examine the expected regeneration of a filter's ability to remove ozone during periods when no air passes through.

To study the impact of oxidation processes on air quality downstream of used filters, sensory assessments of air downstream of four used filter samples were carried out. Human subjects assessed the air quality downstream of the filters before and after those had sat in either nitrogen (no oxidation, best air quality anticipated), ozone (strong oxidation, worst air quality anticipated), ambient air (moderate oxidation anticipated) or ozone-free air at an elevated temperature (moderate oxidation, but enhanced diffusion of organics anticipated).

### **3.2 Further studies of oxidation processes on filter surfaces: Evidence for oxidation products and the influence of time in service (Paper 2)**

The experiments described in Paper 2 further investigate the ozone-initiated oxidation processes on filter surfaces and expand the findings presented in Paper 1.

The main objectives of these studies were:

- *To find an evidence for the production of semi-volatile oxidation products when ozone passes through a loaded filter.* Such products of ozone-initiated reactions may result in an increase in the concentration of secondary organic aerosols. If similar reactions occur on the surfaces of used filters, slight increase of downstream ultrafine particle concentrations may be anticipated. In this experiment, the concentrations of airborne particles upstream and downstream of used filter samples were monitored using a small-scale test rig. Measurements were made with ozone present or absent in the airstream.
- *To examine the filter's ozone removal ability in relation to the length of time it had been in service.* Ozone concentrations up- and downstream of unused and used (2, 4, 8 and 12-weeks-old) filter samples were monitored using a small-scale test rig. The respective ozone removal efficiencies at the beginning and at 60 minutes of each measurement series were calculated and compared. To better understand the role of the new filter material in the removal of ozone from the airstream, three filter samples taken from a new fiberglass bag filter were tested for ozone removal. The first sample (also tested for the regeneration of ozone removal capability) was not treated prior to the measurements, the second sample was ventilated for 48 hours with ozone-free air and the third new filter sample was ventilated for 24 hours with air containing ozone.
- *To examine the ozone removal ability of a filter after it has been protected from ozone during its day-to-day operation.* Two used filter samples were prepared. Ambient air containing ozone was passing through one of the clean filter samples during a 9-week period. The other sample was soiled with the same ambient air, but with the ambient ozone removed. The ozone removal efficiencies of the two filters were investigated at the end of the 9-week soiling period. The amount of ozone that the filter has previously experienced during operation was expected to influence the extent to which ozone reacts as it passes through a loaded filter.

### **3.3 Is the use of particle filtration justified? Costs and benefits of filtration with regard to health effects, building cleaning and occupant productivity** (Paper 3)

The purpose of the study presented in Paper 3 was to derive the estimated economic costs and the corresponding monetized benefits of particle filtration for a standard office building. The study aims to provide a sense of the most important parameters affecting the overall costs and benefits of filtration. The outcomes should facilitate decisions-making regarding filtration strategy in commercial buildings.

The direct costs of filtration include both initial costs and annual running costs. Losses of productivity due to air pollution from used ventilation filters were also taken into consideration. Conversely, occupants' exposure to reduced indoor particle levels provides economic benefits from human health and welfare effects (reduced morbidity and mortality). Filtration also reduces costs in connection with building and HVAC system cleaning. The key input data for certain endpoints in this study may be insufficiently precise. Therefore parametric investigations were performed within the relevant range of the input parameters in order to test the sensitivity of the results to these parameters.

### **3.4 Sensory pollution from bag filters, carbon filters and combinations** (Paper 4)

Lower emissions of sensory offending pollutants from used filters would mean improved air quality, reduced SBS symptoms and increased performance of occupants. This should be preferably achieved with the lowest possible increase in operating costs.

The objective of the study described in Paper 4 was to find such a solution among commercially available ventilation filters. Several ventilation filters and their combinations were tested for their effect on perceived air quality after extensive use under realistic conditions. The filters used in the experiment included EU7 fiberglass bag filters, EU4 pre-filters and activated carbon filters placed at different position in respect to the particle filter. In addition, two types of stand-alone combination filters were evaluated: a bag-type fiberglass filter and a synthetic fiber cartridge filter, both containing activated carbon. After five months of continuous operation outdoors, subjects assessed the quality of air downstream of the used filter sets and downstream of identical sets consisting of new filters. Additionally, the filters' weight and pressure drop were measured at the beginning and end of the operation period.

### **3.5 Factors affecting the accuracy of measuring the pressure drop over ventilation filters** (Paper 5)

The experiments described in Paper 5 investigated the effect of various ventilation ductwork components upstream of a filter unit (bends, reductions, dampers) on the measured pressure drop across a fibrous filter. The influence of the location of pressure sensors on the accuracy of filter pressure drop measurements was studied as well.

Two methods of pressure sensing were evaluated on a ventilation unit that was modified in various ways upstream and downstream of the filter. One of the methods used single up- and downstream pressure-sensing rubber tubes with tips inserted ~2 cm through the wall at various locations on the filter box. The other method used specially developed probes made of 10 mm diameter metal tubes that had six 2 mm diameter holes on the downstream side. Two of such probes were inserted into the filter housing upstream and two downstream of the filter. The probes were anticipated to measure the average static pressure over the cross-section of the filter box, providing thus an accurate reading of the filter pressure drop.

## 4 Methods, results, discussions, conclusions - publications

This section of the thesis consists of the following publications in peer-reviewed journals:

### Paper 1 (chapter 4.1)

**Initial studies of oxidation processes on filter surfaces and their impact on perceived air quality**

Bekö, G., Halás, O., Clausen, G., Weschler, C.J.  
*Indoor Air*, 2006, **16**, 56-64.

### Paper 2 (chapter 4.2)

**Further studies of oxidation processes on filter surfaces: evidence for oxidation products and the influence of time in service**

Bekö, G., Clausen, G., Weschler, C.J.  
*Atmospheric Environment*, 2007, **41**, 5202-5212.

### Paper 3 (chapter 4.3)

**Is the use of particle air filtration justified? Costs and benefits of filtration with regard to health effects, building cleaning and occupant productivity**

Bekö, G., Clausen, G., Weschler, C.J.  
*Building and Environment*, submitted on 28 February, 2007.

### Paper 4 (chapter 4.4)

**Sensory pollution from bag filters, carbon filters and combinations**

Bekö, G., Clausen, G., Weschler, C.J.  
*Indoor Air*, submitted on 30 May, 2007.

### Paper 5 (chapter 4.5)

**Factors affecting the accuracy of measuring the pressure drop over ventilation filters**

Bekö, G.  
*The International Journal of Ventilation*, submitted on 30 May, 2007.

### **Note:**

*Each chapter - paper - appears in the format and layout which meets the respective journal's requirements for submission.*

#### **4.1 Initial studies of oxidation processes on filter surfaces and their impact on perceived air quality**

**Paper published in:**

Indoor Air

**Publisher:**

Blackwell Publishing Ltd., Blackwell Munksgaard

**Citation:**

Bekö, G., Halás, O., Clausen, G., Weschler, C.J. 2006. Initial studies of oxidation processes on filter surfaces and their impact on perceived air quality. *Indoor Air*, **16**, 56-64.

## **Initial studies of oxidation processes on filter surfaces and their impact on perceived air quality**

Gabriel Bekö<sup>1,2</sup>, Oto Halás<sup>1</sup>, Geo Clausen<sup>2</sup>, Charles J. Weschler<sup>2,3</sup>

<sup>1</sup>Faculty of Civil Engineering, Slovak University of Technology, Bratislava, Slovakia

<sup>2</sup>International Centre for Indoor Environment and Energy, Technical University of Denmark

<sup>3</sup>Environmental and Occupational Health Sciences Institute (UMDNJ-Robert Wood Johnson Medical School & Rutgers Univ.), Piscataway, NJ 08854 USA

Corresponding author:

Gabriel Bekö  
International Centre for Indoor Environment and Energy  
Technical University of Denmark  
Nils Koppels Allé, Building 402  
DK-2800 Lyngby, Denmark  
Phone: (+45) 45 25 40 18, fax: (+45) 45 93 21 66  
E-mail: gb@mek.dtu.dk

## **Abstract**

Used filters can be a strong sensory pollutant source. Oxidation processes, especially those initiated by ozone, may contribute to the pollutants emitted from such filters. In the present study ozone was added to the airstream passing through used ventilation filters. Two flowrates were examined. While the upstream ozone concentration was ~75 ppb, the concentrations downstream of the filter were initially 35-50% lower. However, within an hour downstream concentrations were only 5-10% lower than those upstream. These filter samples were then placed for 48 hours in nitrogen, ambient air containing less than 5 ppb ozone, or ambient air at an elevated temperature. This resulted in partial regeneration of the filters' ozone removal capabilities. In analogous experiments, lower ozone removal occurred when the filter samples were first ventilated for 24-hours with ozone-free air before making the measurements. Samples from a new filter removed less than 10% of the ozone in the airstream, and removal remained relatively constant over time. In companion studies, human subjects assessed the air passing through various used filter samples. In the initial evaluation each of the 4 filter samples, taken from the same filter and ventilated for 24 hours, were assessed to be equivalent. The next evaluation occurred immediately after the samples had sat for 24 hours in either nitrogen, air, air at an elevated temperature or ozone. The nitrogen treated filter was assessed to be best, while the ozone-treated filter was assessed to be the worst. The final evaluation occurred after ambient air had passed through the "treated" filters for 2 hours. All such ventilated filters were assessed to be more acceptable than immediately after the 24-hour treatments; the ozonized and air-treated filters were the most polluting of the four.

## **Key words**

Semi-volatile organic compounds; Oxidation; Ozone; Perceived air quality; Ventilation filters; Airborne particles

## **Practical implications**

The present paper supports previous findings that loaded ventilation filters can be significant sources of sensory pollution. Replacing a loaded filter with a new filter temporarily removes this source of pollution. However, the present study does not provide an answer to how frequently changes are needed under different conditions. The results indicate that in cases of intermittent operation of ventilation systems, the airflow through the polluted filters should be restarted in sufficient time prior to occupancy to purge odorous pollutants that have accumulated on the filter surface. Removal of ozone upstream of the particle filters may further improve perceived air quality in the space downstream of the filter bank. Future efforts related to the development and application of low-polluting filtration systems are warranted.

## **Introduction**

A number of field studies have documented that HVAC systems can negatively affect perceived air quality indoors (Fanger et al., 1988; Thorstensen et al., 1990; Pejtersen et al., 1991, Clausen's 2004 review and references therein). Among the numerous components in such systems, loaded ventilation filters were considered to be one of the major sources of

sensory pollutants (Pejtersen et al., 1989; Clausen et al., 2002(a)). Moreover, loaded filters were found to have a negative impact on SBS symptoms and occupant performance (Wyon et al., 2000; Clausen et al., 2002(b); Wargoeki et al., 2003). Bluysen (1993), Pejtersen (1996) and Gholami et al. (1997) documented that the collected particles, through which the ventilation air flows, are a source of sensory pollution. Pasanen et al. (1994) reported a correlation between the mass collected on the filter and the acceptability of the air after the filter. Although several explanations have been offered as to why loaded ventilation filters constitute sensory pollution sources (e.g. microbiological contamination), none seems to be conclusive (see Alm, 2001; Pejtersen, 1996).

The odor and irritancy of indoor pollutants can be altered by chemical transformations (Weschler and Shields, 1997; Weschler, 2000; Weschler, 2004). Similar processes may influence the sensory pollutants associated with ventilation filters. The total surface area of the captured particles accumulated on a filter can easily exceed 500 m<sup>2</sup> for a 0.6 x 0.6 m filter (Weschler, 2003). These surfaces contain adsorbed and absorbed organic compounds. In the air, organic compounds partition between the gas phase and the surface of airborne particles. The resulting distribution is a function of a compound's vapor pressure and both phases tend to be significant for compounds with vapor pressures in the range of  $\sim 10^{-8}$  to  $10^{-12}$  atm. (Weschler, 2003). When a filter captures particles, this partitioning continues between the surface of the collected particles and organic compounds in the air stream (Weschler, 2003). The organic compounds associated with the captured particles fall into different classes in terms of their tendency to desorb from the filter surface. i) Some are in equilibrium with their counterparts in the air flowing through the filter. As long as this is true, their concentrations in the air upstream and downstream of the filter will be the same. However, the equilibrium can be perturbed by changes in temperature, relative humidity, and airstream concentrations of the relevant organics. Each of these influencing factors changes fairly frequently in actual building HVAC systems, often on a time scale of hours. In some cases these changes will result in airstream concentrations that are too small to support the existing concentrations on the filters, and these organics will desorb from the surfaces of the captured particles into the air passing through the filter. ii) Some of the particle-associated organics, at the time of their capture, already have higher surface concentrations than can be supported by their concentrations in the airstream (e.g., certain organics associated with particles generated during combustion processes). These will desorb from the surface of the particles from the moment that the particles are captured. iii) Still other organic compounds are generated on the surfaces of the captured particles through chemical transformations, especially oxidation processes initiated by ozone. Unsaturated organic compounds sorbed on/in the captured particles are most susceptible to oxidation. These include certain oils (e.g., squalene), fatty acids (e.g., oleic acid, linoleic acid, linolenic acid) and fatty acid esters (e.g., linalyl acetate). Many of the oxidation products are semi-volatile. These products may not be present in the air upstream of the filter. Even if present in the upstream air, they may not be present in sufficient concentrations to support their resulting concentrations on the captured particles. If such is the case, they will begin to desorb from the surface of the particles from the moment that they are formed.

Desorption of organic compounds may result in degradation of perceived air quality downstream of the filters. This effect of desorption is expected to vary with location and season, as well as position of the filter in the filter bank. (The studies of Hyttinen et al. (2001) and Pasanen (1998) indicate that loaded pre-filters have higher odor emission rates than loaded final filters). Desorption can be a slow process; it may take hours or days to establish equilibrium (see Won et al., 2000, 2001). Additionally, desorption is influenced by the rate at

which air passes through the filter; Alm et al. (2000) and Strøm-Tejsen et al. (2003) have found that emissions of sensory pollutants from a filter are proportional to the flow rate. In some cases it is anticipated that products are formed at a faster rate than they desorb. In such cases, the oxidized products accumulate over time, and the loaded filters become reservoirs for these products. Consequently, desorption of oxidized products may continue to occur even when oxidation has ceased.

Filters are at the interface between outdoor and indoor air. Outdoor air contains ozone at concentrations ranging from a few ppb to hundreds of ppb. A study carried out by Hyttinen et al. (2003) indicated that loaded ventilation filters remove a fraction of the ozone from air that passes through them. Presumably, ozone removal occurs partly as a consequence of ozone reacting with some of the organic compounds associated with the captured particles on the filter. The oxidation products, when desorbed, may contribute to a negative perception of the filtered air. The purpose of the present study is to further improve our understanding of ozone-initiated oxidation processes occurring on filter surfaces and the impact of these processes on perceived air quality.

## Methods

### *Oxidation processes on the surfaces of used and new filters*

*Measurements* Ozone concentrations were monitored up- and downstream of used and new filter samples, using a small-scale test rig (Figure 1) at two different airflows. The test rig was situated in a 40 m<sup>3</sup> low polluting office ventilated with outside air at 500 m<sup>3</sup> h<sup>-1</sup> through a particle and activated carbon filter; the latter kept the ozone concentration in the room below 5 ppb. The temperature and relative humidity in the test room were not recorded, however the outdoor temperature was moderate throughout the measurement period (between late August and early October).

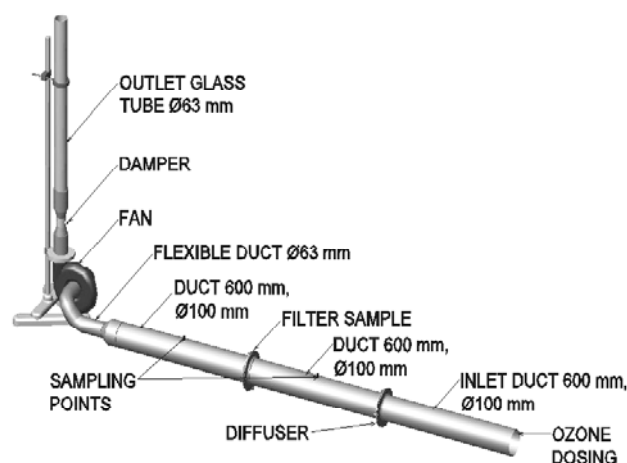

**Figure 1.** Test rig used for ozone consumption measurements

Ozone was added to air that subsequently was delivered to the intake duct of the test rig via a flexible duct. The ozone concentration upstream of the filter sample was held constant at ~75 ppb. Upstream ozone concentrations were measured with a DASIBI 1003 AH (manufacturer no longer in business) ozone meter and downstream concentrations were measured with a SERES OZ 2000 (SERES, Aix-en-Provence, France) ozone meter. The



ozone monitors were cross-calibrated before the experiments and thus provided sufficient precision for determination of relative change in ozone removal. The sampling points were in the center of the duct; the test rig included a radial fan between the point of ozone dosing and the ozone sampling point, insuring adequate mixing.

*Filter samples and procedure* Nine filter samples (see Table 1) of diameter  $\varnothing$  100 mm were cut from a used 0.6 x 0.6 m<sup>2</sup> EU7 fiberglass filter. This filter had been removed from service based on a pressure drop that indicated extensive loading. It had been stored in a plastic bag for several months before these experiments were initiated. Filter samples 1-6 were not ventilated or pre-treated in any fashion before the experiment. Samples 1-3 were placed one by one into the test rig, and initial ozone measurement series were performed at the standard airflow of 1.0 L/s corresponding to a face velocity of 12.5 cm/s. Samples 4-6 were evaluated in a similar fashion, but at a lower flow rate (0.2 L/s or 2.5 cm/s). The initial measurement series lasted until the downstream ozone concentration stabilized. To examine the influence of air-oxidation and diffusion processes on the regeneration of a filter's ability to remove ozone (see Discussion Section), the filter samples were then exposed for 48 hours to one of three static environments:

Nitrogen: samples were placed in a well-sealed glass box, which was subsequently flushed with nitrogen. After flushing the glass box with a quantity of nitrogen approximately equal to its volume (200 L), the nitrogen flow to the box was turned off. No oxidation and moderate diffusion was anticipated to occur under these conditions.

Air: samples were placed into a sealed glass box containing ambient air. The ozone concentration in the glass box was less than 5 ppb. Moderate oxidation and moderate diffusion was expected to occur under these conditions.

Increased temperature (heat): samples were placed in an oven maintained at 100 °C that was supplied with particle and ozone-filtered outside air. Moderate oxidation and enhanced diffusion was expected to occur under these conditions.

After the 48 hour exposures, ozone measurements were again made upstream and downstream of each filter using both standard and low airflows. Each measurement series lasted approximately 1 to 2 hours depending on the rate of change in ozone concentrations downstream of the filter.

Filter samples 7-9 were examined at low airflow after being ventilated with ozone-free air at a flow rate of 1.0 L/s for 24 hours prior to the measurements. The experimental setup and procedure were analogous to those of the previous measurements, differing only in the length of filter treatment in the static atmospheres (now 24 hours).

To provide information on the contribution of new filters to the observed ozone losses, two samples (N1 and N2) of diameter  $\varnothing$  100 mm taken from a new EU7 fiberglass bag filter were investigated for ozone removal at two different airflows using the identical setup and upstream ozone concentration as described for the previous experiments. The filter samples were neither treated nor ventilated prior to the initial measurement series.

*Data processing* The ozone removal efficiency for a given time step ( $E_i$ ) was determined using Equation 1:

$$E_i = \frac{U_i - D_i}{U_i} \times 100 \quad [\%] \quad (1)$$

Where:  $U_i$  - Upstream ozone concentration for the given time step [ppb]

$D_i$  - Downstream ozone concentration for the given time step [ppb]

$i$  - Time step for data logger – 0.9 s

Upstream ozone concentrations were intended to be constant. However, there was a slight drift in those values. Consequently, to reduce the impact of instrument noise, the values used in Equation (1) were derived from a fitted equation. The initial removal efficiency ( $E_0$ ) at the beginning of each measurement series was based on the average of data collected during the first 72 seconds after the system achieved stability following the insertion of filter samples into the test rig. The removal efficiency at the end of each measurement series ( $E_\infty$ ) was based on the average of data collected during the last 450 seconds.

The amount of ozone removed from the air stream by a filter during a given time step ( $R_i$ ) was calculated using Equation 2:

$$R_i = (U_i - D_i) 1.96 q \times 0.9 \quad [\mu\text{g}] \quad (2)$$

Where  $U_i$ ,  $D_i$  and  $i$  are as previously defined and:

$q$  - Airflow ( $0.001 \text{ m}^3 \text{ s}^{-1}$  for standard airflow and  $0.0002 \text{ m}^3 \text{ s}^{-1}$  for low airflow)

1.96 –  $\mu\text{g} \cdot \text{m}^{-3}$ , corresponding to 1 ppb ozone at 25 °C

0.9 – Interval for one time step [s]

Ozone consumptions were calculated for periods of 10, 30 and 50 minutes.

#### *Effects on sensory assessments*

To study the impact of oxidation processes on sensory assessments of filters, four filter samples were treated in four different manners. Four identical small-scale test rigs for facial exposure (Figure 2) were placed in an experimental office identical with that used in the ozone removal efficiency experiments. The air temperature in the office was maintained at 22 °C throughout the experiment. The airflow through the filter samples was adjusted to 1.0 L/s. The tested samples were taken from a  $0.6 \times 0.6 \text{ m}^2$  EU7 fiberglass filter that had been in continuous service for three months as an outdoor air filter in a suburb of Copenhagen, Denmark. This filter was not as heavily loaded as the one used in the ozone removal experiments. Its use permitted us to distinguish differences in perceived air quality that would have been more difficult to observe with the heavily loaded filter. The experiment was conducted between 19 and 21 October 2003.

Four used filter samples (100 mm diameter) were first ventilated in the test rigs for 24 hours. Three of them were then placed for an additional 24 hours in separate 200 L sealed glass chambers containing either ozone, nitrogen or ambient air. An ozone concentration of approximately 400 ppb was maintained in the first glass box throughout the exposure period. The 2<sup>nd</sup> glass box was flushed with nitrogen and sealed after inserting the sample, similar to the procedure followed in the removal efficiency experiments. Ambient air containing no ozone was in the 3<sup>rd</sup> glass chamber. The fourth ventilated sample was placed for 24 hours in an oven heated to 100 °C. The oven contained ozone-free ambient air.

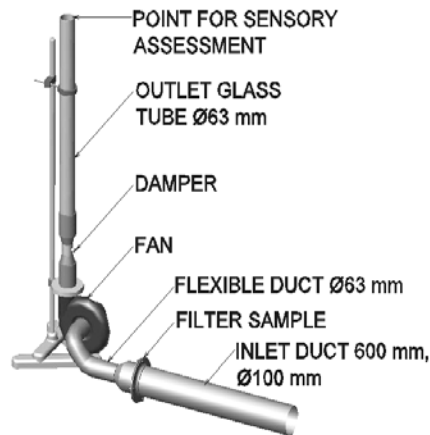
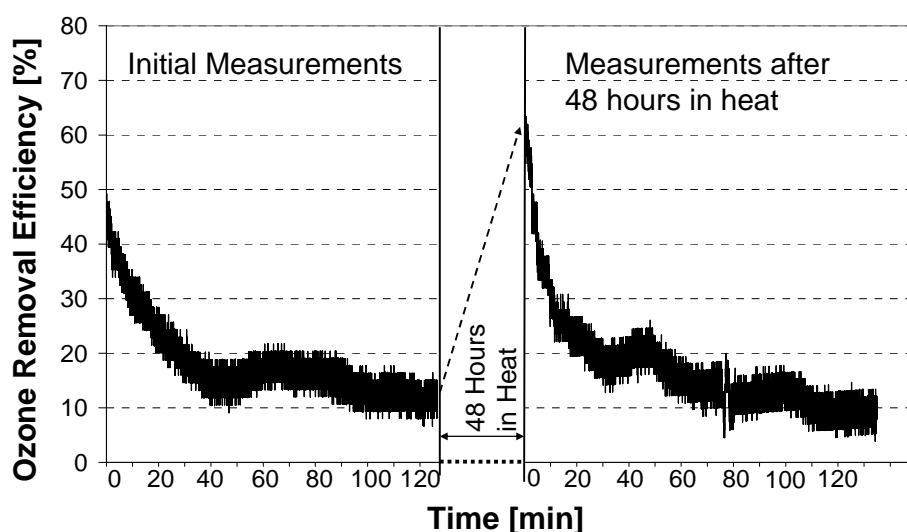

**Figure 2.** Test rig used for sensory assessments by facial exposure

Three sets of sensory assessments were conducted: 1) before treatment in order to ensure that all four samples initially had equivalent effects on perceived air quality, 2) immediately after the treatment, and 3) after air had flowed through the filters for two hours. Between 19 and 20 human subjects participated in each assessment. The subjects used a continuous acceptability scale to evaluate the air quality. They made assessments one at a time, and there was at least one minute of refreshment between assessments for each subject.

## Results

Figure 3 displays an example of ozone removal efficiencies (sample 6) before and after a loaded filter had sat for 48 hours in heat. A low airflow (0.2 L/s) was used in this example. Initially, the ozone removal efficiency was 44%. Over time the filter removed less ozone, with the removal efficiency dropping to approximately 12% after two hours. Upon re-evaluation, after 48 hours in an oven (100°C), the ozone removal efficiency was found to have increased from 12% to 61%. During the next ~ 2 hours the removal efficiency decayed to 9%. Figure 4 similarly shows the ozone removal efficiencies corresponding to filter sample 9, which was ventilated 24 hours before the initial measurement series and placed in heat for only 24 hours before re-evaluation.



**Figure 3.** Ozone removal efficiency of filter sample 6 versus time; airflow =  $0.2 \text{ L s}^{-1}$ ; after ~120 minutes the filter was heated for 48 hours before re-evaluation

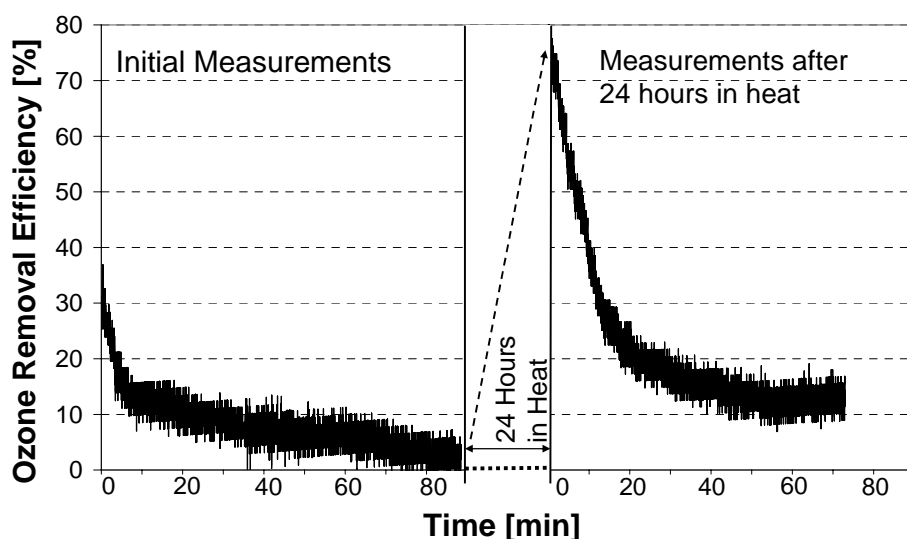

**Figure 4.** Ozone removal efficiency of filter sample 9 versus time; sample 9 had been ventilated for 24 hours before the initial evaluation; airflow =  $0.2 \text{ L s}^{-1}$ ; after ~90 minutes the filter was heated for 24 hours before re-evaluation

Table 1 lists removal efficiencies for all tested used filter samples. For the filters that were not ventilated before the measurement series (samples 1-6), the average ozone removal efficiency at the beginning of each measurement series ( $E_0$ ) was higher at the low airflow (samples 4-6) than at the standard airflow (samples 1-3). This was true for both the initial measurement series as well as the measurement series conducted after the filters had sat for 48 hours in air, heat or nitrogen. Moreover, generally higher initial ozone removal was obtained at the same airflow for samples without pre-treatment (samples 4-6) than for the ones ventilated prior to the initial measurement series (samples 7-9). Table 2 shows the amount of ozone cumulatively consumed after 10, 30 and 50 minutes before and after each filter sample was treated. Analogous results for the new filter samples are displayed in Table 3; for the new filters there is no change in ozone removal efficiencies over time.

**Table 1.** Ozone removal efficiencies of the nine filter samples at the beginning ( $E_0$ ) and end ( $E_\infty$ ) of the measurement series both before and after filter treatment; samples 7-9 had been ventilated for 24 hours before the initial evaluation

Sample	Airflow [L.s <sup>-1</sup> ]	Initial Measurements		Treatment	Treatment time [h]	Subsequent Measurements	
		Removal Efficiency [%]				Removal Efficiency [%]	
		Beginning ( $E_0$ )	End ( $E_\infty$ )			Beginning ( $E_0$ )	End ( $E_\infty$ )
1	1.0	38	2	Air	48	16	2
2	1.0	34	6	Nitrogen	48	17	4
3	1.0	38	8	Heat	48	33	5
4	0.2	51	8	Air	48	34	9
5	0.2	60	11	Nitrogen	48	41	13
6	0.2	44	12	Heat	48	61	9
7	0.2	26	5	Air	24	22	6
8	0.2	47	14	Nitrogen	24	35	9
9	0.2	29	3	Heat	24	75	13

**Table 2.** Ozone consumptions for the nine filter samples at 10, 30 and 50 minutes during initial and subsequent measurement series; samples 7-9 had been ventilated for 24 hours before the initial evaluation

Sample	Airflow [L.s <sup>-1</sup> ]	Initial Measurements			Treatment	Treatment time [h]	Subsequent Measurements		
		Ozone consumption [ $\mu$ g]					Ozone consumption [ $\mu$ g]		
		10 min	30 min	50 min			10 min	30 min	50 min
1	1.0	21	38	44	Air	48	12	27	37
2	1.0	21	38	48	Nitrogen	48	9.8	20	29
3	1.0	23	52	71	Heat	48	24	51	63
4	0.2	7.3	15	19	Air	48	5.0	12	18
5	0.2	8.2	17	21	Nitrogen	48	5.7	14	20
6	0.2	6.7	16	21	Heat	48	7.7	16	23
7	0.2	3.0	6.4	9.3	Air	24	2.0	5.8	9.2
8	0.2	6.3	16	24	Nitrogen	24	5.3	11	15
9	0.2	3.2	6.9	9.6	Heat	24	11	19	25

**Table 3.** Ozone removal efficiencies and ozone consumptions for a new filter at two different airflows

Sample	Airflow [L.s <sup>-1</sup> ]	Initial Measurements				
		Removal Efficiency [%]		Ozone consumption [ $\mu$ g]		
		Beginning ( $E_0$ )	End ( $E_\infty$ )	10 min	30 min	50 min
N1	0.2	10	10	1.6	4.7	7.9
N2	1.0	2	2	1.3	4.3	7.9

Figure 5 shows results from the sensory assessments of air that had passed through the filters. The distribution of data was tested for normality with the Shapiro-Wilk's test. All data were normally distributed; differences between assessments were tested by Paired t-Test or Standard Two-Sample t-Test, where applicable. Assessments made before treatment revealed no significant differences among the four samples. In the assessments immediately following treatment, the ozonized filter had the greatest impact on the quality of air passing through it. The degradation of perceived air quality was significantly greater than before this filter

sample had sat in an ozone atmosphere ( $p < 0.01$ ). Similar results were obtained for the heat ( $p < 0.05$ ) and air ( $p < 0.01$ ) treated filter samples, whereas the nitrogen treatment did not significantly change the impact of the filter sample on the perceived air quality ( $p > 0.05$ ).

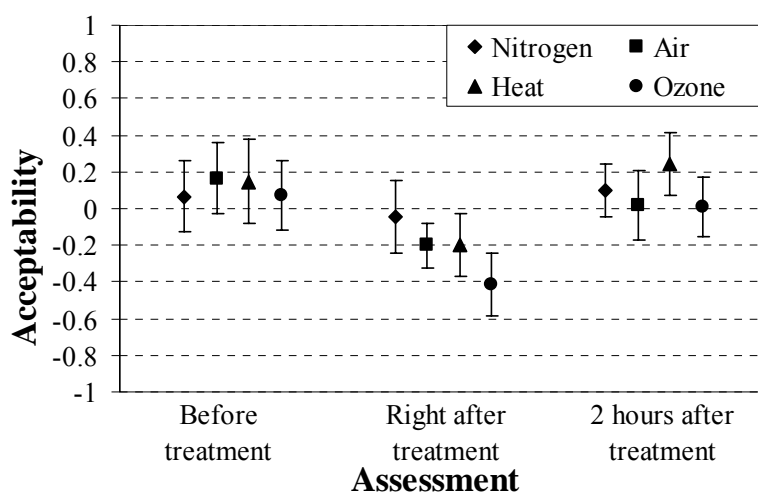

**Figure 5.** Acceptability of the air downstream of the filter samples; assessments (facial exposure) before, immediately after and 2 hours after treatment. The mean values and the 95% confidence intervals are shown

After 2 hours of ventilation, assessments of the samples indicated that all the filters had improved in comparison with their assessments immediately following the treatments. However, only in the case of the ozone ( $p < 0.01$ ) and heat-treated filters ( $p < 0.01$ ) were the changes significant. The heated filter was found to be the most acceptable one after the third set of assessments. The ozonized and air treated filters remained the most polluting of the four. The air downstream of the nitrogen treated filter did not change its quality significantly throughout the entire experiment ( $p > 0.05$ ).

## Discussion

In Experiments 1-9, ozone concentrations decreased as air passed through loaded fiberglass filters; the magnitude of this decrease grew smaller as the amount of time that ozone passed through the filters increased. We assume that this reflects a combination of ozone-consuming chemical reactions and catalyzed ozone decomposition. To elaborate, some of the organic compounds associated with the particles collected on the filter contain unsaturated carbon-carbon bonds (e.g., unsaturated fatty acids, terpenes, and sesquiterpenes commonly found in plant waxes, pollen and vegetative detritus (Weschler, 2000; Hyttinen et al., 2003)). These compounds react with ozone much faster than saturated organic compounds and are likely responsible for a fraction of the observed ozone consumption. However, reactive ozone consumption is limited by the amount of such compounds on the loaded filter surface. In the depicted examples (Figures 3 and 4) ozone removal decayed until it reached a steady-state value (after  $\sim 1.5 - 2$  hours). We interpret this decrease as corresponding to depletion, as a consequence of chemical reaction or desorption, of reactive organics on the filter surface. The residual ozone removal measured after the first couple of hours may be due to catalytic destruction of ozone and is not affected by consumption of unsaturated organics on the filter surface. To some extent, the residual may also represent a quasi-equilibrium between

unsaturated organics diffusing to the surface and those same species being depleted by either reacting with ozone or desorbing from the surface of the filter as air passes through.

The ozone removal efficiency decayed in a similar fashion for all of the used filter samples. Values of  $E_0$  (Beginning Removal Efficiency) from initial measurement series are fairly similar for samples measured at standard airflow (from 34 to 38%); larger variances occurred among samples measured at low airflow (from 44 to 60% - samples 4-6; from 26 to 47% - samples 7-9). This may be due to differences in the number and nature of particles deposited at different locations in a multi-bag filter; indeed, even within the same bag, localized differences may occur.

For filters that have not been ventilated prior to the measurements, comparison of ozone consumptions after 10 minutes of measurements at standard airflow (21-23  $\mu\text{g}$ ; Samples 1-3 in Table 2) and after 50 minutes at low airflow (19-21  $\mu\text{g}$ ; Samples 4-6 in Table 2) indicates that approximately the same amount of ozone was consumed for an equivalent volume of air (600 L) - and thus of ozone - passing through the filter. This indicates that, despite the different flowrates, the processes responsible for ozone removal were occurring to the same extent per number of ozone molecules passing through the filter. A quite different result was observed for the new filters that contained no captured particles. During 10 minutes at 1.0 L/s, 1.3  $\mu\text{g}$  of ozone was consumed, while over 50 minutes at 0.2 L/s, 7.9  $\mu\text{g}$  of ozone was consumed. The velocity at which the air passes through the filter (i.e., the contact time) made a large difference for ozone removal by these unsoiled new filters whereas it made no observable difference for ozone removal by loaded filters.

On average, lower initial ozone removal efficiencies,  $E_0$ , were measured for filters that had been ventilated for 24-hours (samples 7-9) than for filters that had not been ventilated. Ventilation is expected to desorb some of the organics that might otherwise have reacted with ozone. The final ozone removal efficiencies,  $E_\infty$  (5 % at standard airflow, 9 % at low airflow) are not anticipated to change further over time. These values are close to the ones reported by Hyttinen et al. (2003), who indicated that used air filters remove 4 to 10 % of ozone from the air stream during a 6 – 9 hr interval. Moreover, in evaluating one brand of new filter we found similar low removal efficiencies (10% at low airflow, and 2% at standard airflow), and these removal efficiencies remained constant throughout the measurement series. The high initial removal of ozone on used filters is presumably caused by reactions with organic matter captured on the filter, while the final ozone removal efficiency,  $E_\infty$ , for the loaded filters is caused by a combination of reactions and catalytic decomposition (see above). This conclusion is supported by the observation that new filters, which do not contain captured organic compounds, also removed a fraction of ozone from the air stream. (Note, however, that not all filters are manufactured the same way. In experiments to be published in a future report we have evaluated a different type of filter that removes significant amounts of ozone when it is new.)

After the various 48-hour treatments the initial removal efficiencies were partially, or in the case of heat treatment, fully regenerated. These results suggest that the amount of reactive organics on the filter surface increases during non-operating intervals. Organic compounds are not only found on the surface of loaded filters, i.e. on the surface of the collected particles, but also within the particles. The latter compounds can neither be oxidized nor desorbed from the filter until they have diffused from the interior to the surface of particles. Presumably under static conditions (i.e., when air is not passing through the filter), the rate of desorption of organic compounds from the filter surface decreases. Thus, the ratio of the “rate of

diffusion to the surface” to the “rate of desorption from the filter surface” is greater when no air is passing through the filter, which may help to explain the regeneration of a filter’s ability to remove ozone.

Regeneration results obtained after nitrogen and air treatments were similar, while heat treatment evoked a larger regeneration of the ozone removal efficiency at both low and standard airflows. After the filters had been placed for 48 hours (or 24 hours) in different static environments, the amount of ozone consumed by the filters that had been heated was larger than that consumed by filters that had sat in air or nitrogen at room temperature. This was true at the standard airflow (Sample 3 vs. Samples 1 and 2), at the low airflow after 48 hrs (Sample 6 vs. Samples 4 and 5) and at the low airflow after 24 hours (Sample 9 vs. Samples 7 and 8). An elevated temperature accelerates the rate of diffusion; this, in turn, may lead to a larger amount of organic compounds on the surface of the heated filter sample than in the other two cases. Heating also removes water from the filter cakes, which likely influences ozone removal efficiencies. However, when the filter is removed from the oven and placed in the test rig, partial re-equilibration with moisture in the surrounding air is anticipated. At present the above is speculation, and the processes responsible for the observed regeneration remain to be determined.

Sensory evaluations showed significant effects of ozone, heat and air treatments, as well as ventilation, on the filter specimens. During the 24-hour treatments in static environments, organics susceptible to oxidation are expected to diffuse to the surface of the particles captured on the filter surface. More organic compounds are anticipated to replenish the surface of the heated filter than the surface of unheated filters (see above). Thus, subsequent ventilation for 2 hours is anticipated to be more beneficial for previously heated filters. Significant improvement by 2 hours of ventilation was also observed for the ozonized filter. Ozone is assumed to cause oxidation of unsaturated organics on the filter surface producing new products with a range of volatilities. In the static environment the oxidation products tend to desorb at a rate that is slower than the rate at which they desorb when air is passing through the filter. Volatile oxidation products could contribute to the degradation of air quality immediately after treatment, but after 2 hours of ventilation many of these accumulated volatile oxidation products will have been desorbed. Oxidation is also assumed to occur, but to a lesser extent, during air treatment as well as during heating in the presence of air in the oven. However, no oxidation is anticipated in the nitrogen atmosphere. The results of the sensory evaluations are consistent with these assumptions.

Mysen et al. (2003) report that turning off or reducing the air flow outside working hours increases the sensory pollution emitted from a used bag-filter immediately after the ventilation system is turned on, in comparison with continuous flow. Similarly, after restarting the HVAC system, Mølhav and Thorsen (1989) found a dramatic rise in the concentration of organic compounds in spaces served by the ventilation system. When air is passing through a ventilation filter, the desorption rate for volatile and semi-volatile organics is faster than during static conditions and apparently faster than their rate of regeneration (via diffusion or other processes). Hence, the organics and their oxidation products do not accrue as fast on the filter surface. When ventilation ceases, the filter may once again become “recharged” with sensory pollutants via a combination of diffusive and oxidative processes. This could partly explain the perceived deterioration in air quality originating from loaded ventilation filters immediately following periods when HVAC systems have not been operated.



The results obtained for the air, ozone and nitrogen treated filter specimens are consistent with results acquired in earlier analogous experiments carried out by Bekö et al. (2003). However, the mean acceptability values in the present experiment are higher on average by 0.2 units. In the present experiments, efforts were made to exclude ozone from the room during the initial ventilation of the filters, the subsequent 2-hour ventilation, and throughout the sensory assessments. This precaution was not taken during the earlier experiments. Moreover, different sensory panels and other factors (e.g., time of the year) may contribute to the observed differences.

## Summary

Loaded particulate filters removed ozone from the air that passed through them. The removal of ozone by a loaded filter decreased over time. This supports the assumption that a fraction of the organics or soot associated with the particles accumulated on the filter surface was oxidized by ozone in the air that passed through the filter. Contrasting standard and low flowrates, the same amount of ozone was consumed after an equivalent volume of air passed through the loaded filter. Passing air through a loaded filter promoted desorption of organics from the filter surface. A filter that had been ventilated with ozone free air for 24 hours initially removed less ozone than a filter that had not been ventilated in this fashion. In either case, after one to two hours the ozone removal efficiency approached a small and constant value. Along with residual oxidation reactions, this latter removal efficiency may also reflect catalytic decomposition, which does not depend on the availability of oxidizable organic material on the filter surface. If a “depleted” loaded filter was placed in a static environment (no air passing through the filter), it regained some of its ability to remove ozone. This regeneration was enhanced if the filter sat at an elevated temperature during the regeneration period. At present, the processes responsible for this regeneration are not fully understood. Although removal of ozone is desirable, the resulting oxidation processes appear to be responsible for the generation of products that contribute to the degradation of perceived air quality, especially after periods when the ventilation system is not in operation.

## Acknowledgements

This work has been supported by the Danish Technical Research Council (STVF) as part of the research program of the International Centre for Indoor Environment and Energy established at the Danish Technical University for the period 1998-2007.

## References

- Alm, O., Clausen, G. and Fanger, P.O. (2000) “Exposure-response relationships for emissions from used ventilation filters”, In: *Proceedings of Healthy Buildings 2000*, Espoo, Vol. 3, 156-162.
- Alm, O. (2001) “Ventilation filters and their impact on human comfort, health and productivity”, *Doctoral dissertation, International Centre for Indoor Environment and Energy, Technical University of Denmark*. Ph.D.-thesis MEK-I-Ph.D. 01.02.
- Bekö, G., Halás, O., Clausen, G., Weschler, C.J. and Toftum J. (2003) “Initial studies of oxidation processes on filter surfaces and their impact on perceived air quality”, In: *Proceedings of Healthy Buildings 2003*, Singapore, Vol. 3, 156-162.

- Bluyssen, P. (1993) "Do filters pollute or clean the air?", *Air Infiltration Review*, Vol.14, No.2, March 1993, 9-13.
- Clausen, G., Alm, O. and Fanger, P.O. (2002) "The impact of air pollution from used ventilation filters on human comfort and health", In: *Proceedings of the 9<sup>th</sup> International Conference on Indoor Air Quality and Climate INDOOR AIR 2002*, Monterey, USA, Vol. 1, 338-343.
- Clausen, G., Alm, O. and Fanger, P.O. (2002) "Sensory strength of used ventilation filters", In: *Proceedings of the 9<sup>th</sup> International Conference on Indoor Air Quality and Climate INDOOR AIR 2002*, Monterey, USA, Vol. 1, 344-349.
- Clausen, G. (2004) "Ventilation filters and indoor air quality: a review of research from the International Centre for Indoor Environment and Energy", *Indoor Air*, **14**, S7, 202-207.
- Fanger, P.O., Lauridsen, J., Bluyssen, P. and Clausen, G. (1988) "Air pollution sources in offices and assembly halls, quantified by the olf unit", *Energy and Buildings*, **12**, 7-19.
- Gholami, S., Pejtersen, J., Clausen, G. and Fanger, P.O. (1997) "Sensory pollution load caused by HVAC components", In: *Proceedings of IAQ '97 Healthy Buildings*, Washington DC, USA, Vol. 1, 545-550.
- Hyttinen, M., Pasanen, P. and Kalliokoski, P. (2001) "Adsorption and desorption of selected VOCs in dust collected on air filters", *Atmospheric Environment*, **35**, 5709-5716.
- Hyttinen, M., Pasanen, P., Salo, J., Björkroth, M., Vartiainen, M. and Kalliokoski, P. (2003) "Reactions of ozone on ventilation filters", *Indoor and Built Environment 2003*, **12**, 151-158.
- Mølhav, L. and Thorsen, M. (1989) "Konsekvenserne af øget recirculation i ventilationsanlæg", *Institut for Miljø- og Arbejdsmedicin, Århus Universitet*, (in Danish).
- Mysen, M., Clausen, G., Bekö, G. and Halás, O. (2003) "The influence of typical ways of operating an air-handling unit on the sensory pollution load from used bag filters", In: *Proceedings of Healthy Buildings 2003*, Singapore, Vol. 3, 267-272.
- Pasanen, P., Teijonsalo, J., Seppänen, O., Ruuskanen, J. and Kalliokoski, P. (1994) "Increase in perceived odor emissions with loading of ventilation filters", *Indoor Air*, **4**, 106-113.
- Pasanen, P. (1998) „Emissions from filters and hygiene of air ducts in the ventilation systems of office buildings“, *Doctoral dissertation, Kuopio University Publications C. Natural and Environmental Sciences* 80, 1-77.
- Pejtersen, J., Bluyssen, P., Kondo, H., Clausen, G. and Fanger, P.O. (1989) "Air pollution sources in ventilation systems", In: *Proceedings of CLIMA 2000*, Sarajevo, August 1989, Vol. 3, 139-144.
- Pejtersen, J., Clausen, G., Sørensen, J., Quistgaard, D., Iwashita, G., Zhang, Y., Onishi, T. and Fanger, P.O. (1991) "Air pollution sources in kindergartens", In: *Proceedings of IAQ '91 Healthy buildings*, Washington DC, USA, ASHRAE, 221-224.
- Pejtersen, J. (1996) "Sensory pollution and microbial contamination of ventilation filters", *Indoor Air*, **6**, 239-248.
- Strøm-Tejse P., Clausen G., Toftum J. 2003. "Sensory pollution load from a used ventilation filter at different airflow rates", In: *Proceedings of Healthy Buildings 2003*, Singapore, Vol. 3, 257-261
- Thorstensen, E., Hansen, C., Pejtersen, J., Clausen, G. and Fanger, P.O. (1990) "Air pollution sources and indoor air quality in schools", In: *Proceedings of the 5<sup>th</sup> International Conference on Indoor Air Quality and Climate INDOOR AIR '90*, Toronto, Vol. 1, 531-536.
- Wargocki, P., Wyon, D.P. and Fanger, P.O. (2003) "Call-centre operator performance with new and used filters at two different outdoor air supply rates", In: *Proceedings of Healthy Buildings 2003*, Singapore, Vol. 3, 213-218.

- Weschler, C.J. and Shields, H.C. (1997) "Potential reactions among indoor pollutants", *Atmospheric Environment*, **31**, 3487-3495.
- Weschler, C.J. (2000) "Ozone in indoor environments: Concentration and chemistry", *Indoor Air*, **10**, 269-288.
- Weschler, C.J. (2003) "Indoor/outdoor connections exemplified by processes that depend on an organic compound's saturation vapor pressure", *Atmospheric Environment*, **37**, 5455-5465.
- Weschler, C.J. (2004) "Chemical reactions among indoor pollutants: what we've learned in the new millennium", *Indoor Air*, **14**, S7, 184-194.
- Won, D., Corsi, R.L. and Rynes, M. (2000) "New indoor carpet as an adsorptive reservoir for volatile organic compounds", *Environmental Science & Technology*, **34**, 4193-4198.
- Won, D., Corsi, R.L. and Rynes, M. (2001) "Sorptive interactions between VOCs and indoor materials", *Indoor Air*, **11**, 246-256.
- Wyon, D.P., Tham, K.W., Croxford, B., Young, A., Oreszczyn, T. (2000) "The effects on health and self-estimated productivity of two experimental interventions which reduced airborne dust levels in office premises", In: *Proceedings of Healthy Buildings 2000*, Espoo, Vol. 1, 641-646.

## **4.2 Further studies of oxidation processes on filter surfaces: evidence for oxidation products and the influence of time in service**

**Paper published in:**

Atmospheric Environment

**Publisher:**

Elsevier

**Citation:**

Bekö, G., Clausen, G., Weschler, C.J. 2007. Further studies of oxidation processes on filter surfaces: evidence for oxidation products and the influence of time in service. *Atmospheric Environment*, **41**, 5202-5212.

## **Further studies of oxidation processes on filter surfaces: Evidence for oxidation products and the influence of time in service**

Gabriel Bekö <sup>a, b</sup>, Geo Clausen <sup>b</sup>, Charles J. Weschler <sup>b, c</sup>

<sup>a</sup> Faculty of Civil Engineering, Department of Building Services, Slovak University of Technology, Radlinského 11, 813 68 Bratislava, Slovakia

<sup>b</sup> International Centre for Indoor Environment and Energy, Department of Mechanical Engineering, Technical University of Denmark, Nils Koppels Allé, Building 402, DK-2800 Lyngby, Denmark

<sup>c</sup> Environmental and Occupational Health Sciences Institute, UMDNJ-Robert Wood Johnson Medical School & Rutgers University, Piscataway, NJ 08854 USA

Corresponding author:

Gabriel Bekö  
International Centre for Indoor Environment and Energy  
Technical University of Denmark  
Nils Koppels Alle, Building 402  
DK-2800 Lyngby, Denmark  
Phone: (+45) 45 25 40 18, fax: (+45) 45 93 21 66  
E-mail: gb@mek.dtu.dk

## **Abstract**

The sensory pollutants emitted by loaded ventilation filters are assumed to include products formed via oxidation of organics associated with captured particles. In this study experiments were performed that used either particle production or ozone removal as probes to further improve our understanding of such processes. The measured ratio of downstream to upstream submicron particle concentrations increased when ozone was added to air passing through samples from loaded particle filters. Such an observation is consistent with low volatility oxidation products desorbing from the filter and subsequently partitioning between the gas phase and the surface of particles that have passed through the filter, including particles that were previously too small (< 20 nm) to be detected by the instrument used in these studies. A related set of experiments conducted with unused filters and filters that had been in service from 2 to 16 weeks found that ozone removal efficiencies changed in a manner that indicated at least two different removal mechanisms – reactions with compounds present on the filter media following manufacturing and reactions with compounds associated with captured particles. The contribution from the former varies with the type and manufacturer of the filter, while that of the latter varies with the duration of service and nature of the captured particles. In complimentary experiments, a filter sample protected from ozone during its 9 weeks of service had higher ozone removal efficiencies than an identical filter not protected from ozone during the same 9 weeks of service filtering the same air. This result indicates that a filter's exposure history subsequently influences the quantity of oxidation products generated when ozone-containing air flows through it.

## **Key words**

Sub-micron particles; Gas/Particle Partitioning; Oxidation; Ozone; Ventilation filters; Semi-volatile organic compounds

## **1. Introduction**

Filters remove particles from ventilation air and thus reduce occupant exposure to airborne particles and the rate at which HVAC components accumulate dust and grime. However, particulate filters also introduce sensory pollutants into the air that passes through them. Studies have reported that particle loaded ventilation filters can degrade perceived indoor air quality (Pejtersen et al., 1989, 1996; Pasanen et al., 1994, 1998; Clausen, 2004 and references therein), increase sick building syndrome symptoms (Clausen et al. 2002) and decrease performance (Wargocki et al., 2004, Wyon et al., 2000). The sensory pollutants emitted by loaded ventilation filters are assumed to be a mixture of organic compounds associated with particles collected on the filters, organic compounds formed on the filter as a consequence of chemical reactions (Bekö et al., 2006; Hyttinen et al., 2001) and, in some cases, microbial activity. The link between oxidation chemistry and altered odor and irritancy of indoor pollutants has previously been discussed (Weschler, 2000, 2004; Wolkoff and Nielsen, 2001; Klenø-Nøjgaard et al., 2005; Tamás et al., 2006). Oxidation processes, especially those driven by ozone, are expected to be the dominant chemical transformations occurring on filter surfaces and may contribute to their adverse sensory impact (Bekö et al., 2003, 2006). Consistent with this expectation, several studies have documented that particle filters remove a fraction of ozone from the airstream (Bekö et al., 2006; Hyttinen et al., 2003, 2006; Zhao et al., 2005). The high initial removal of ozone by ventilation filters is assumed to be due to reactions of ozone with organic compounds present on the filter surfaces.

The fraction of ozone consumed by a filter is expected to vary with the service life of the filter and, to some extent, the time since the flow of air through the filter was last interrupted (Bekö et al., 2006; Hyttinen et al., 2006). Hyttinen et al. (2006) examined the ozone removal efficiencies of new and loaded pre-filters (G3) and final filters (F8). Consistent with Bekö et al. (2006), they found that ozone removal was highest when air that contained ozone initially passed through a loaded filter, and that removal efficiencies decreased significantly during the first hour. They also found that removal of ozone increased as the dust load on the pre-filters increased. Pre-filters with  $5 \text{ g m}^{-2}$  of dust removed 12% of the ozone in the airstream during the first hour while pre-filters with  $36 \text{ g m}^{-2}$  removed 35% of the ozone. Although the dust loading on the fine filters was not as large as that on the coarse filters, a similar trend was observed at higher humidities (74-80% RH). They also observed that the filters recovered some of their ability to remove ozone during breaks in ozone exposure. Bekö et al. (2006) measured an ozone removal efficiency of approximately 5 to 10% for a soiled filter that had been in continuous operation for an extended period, however the removal efficiency was as high as 50% when the simulated HVAC system was first turned on after several hours of inactivity. The authors hypothesized that the regeneration of the filter's ozone removal potential during the static period (i.e., no airflow through the filter) was due to diffusion of reactive organic compounds from the interior of the captured particles to their surface, where they could subsequently react with ozone. Desorption of an oxidized product can then occur if it has a surface concentration that is larger than its equilibrium surface concentration. The rate of desorption from the filter surface is expected to accelerate when air is passing through a filter.

Hyttinen et al. (2006) found that formaldehyde production occurred as ozone was removed from the air passing through a loaded filter. During the first 70 minutes of ozone exposure, the formaldehyde yield was 11% of the ozone consumption. Additionally, during ozone exposure the concentration of  $\text{C}_5\text{-C}_{10}$  aldehydes was higher downstream than upstream of loaded filters. After ozone-containing air had passed through a loaded filter for a few hours, formaldehyde production was no longer detectable. Essentially, the authors found that formaldehyde and higher aldehydes were produced as loaded filters removed ozone, and the rate of production decreased as ozone removal by the loaded filter decreased. Soiled duct liners bear some resemblance to soiled filters, but the air passes over the dust deposits rather than through them. Morrison et al. (1998) found that soiled duct liners were significantly stronger emitters of organic compounds, including  $\text{C}_6\text{-C}_{10}$  aldehydes, than new duct liners. Additionally, the authors found some indication that soiling increased the uptake of ozone by HVAC components.

In the context of improving our understanding of ozone-initiated oxidation processes on filter surfaces, this study had three specific objectives: 1) to look for evidence of the production of semi-volatile oxidation products when ozone passed through a loaded filter; 2) to examine variations in ozone removal with the length of time that a filter was in service; 3) to examine subsequent ozone removal when a filter has been protected from ozone during its day-to-day operation.

## 2. Methods

### 2.1. Particles

The concentrations of airborne particles (0.02 to 1  $\mu\text{m}$  diameter) upstream and downstream of used filter samples were monitored using a small-scale test rig (Figure 1). Measurements were made with approximately 75 ppb of ozone in the airstream or with less than 3 ppb ozone in the airstream.

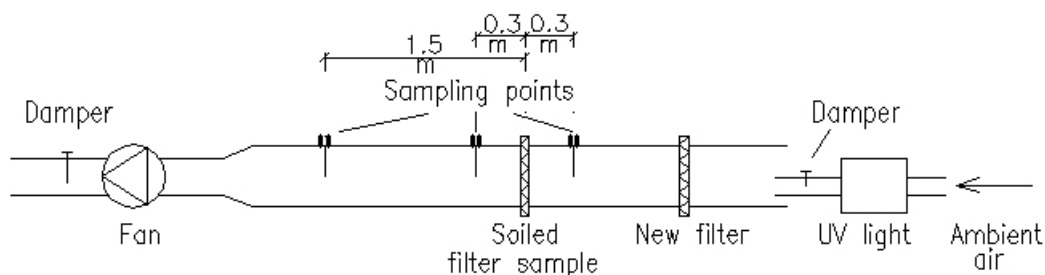

**Figure 1.** Small-scale test rig used for the particle measurements

Filter samples (100 mm diameter) were cut from a 0.6 x 0.6 m EU7 fiberglass filter that had been used for a substantial period of time in a suburban area of Copenhagen and subsequently stored for several months. Visual inspection indicated significant particle accumulation on the tested filter, but the number of hours that air actually passed through the filter was not known. The experimental conditions are shown in Table 1. Each experiment lasted approximately 1.5 hours, during which an average particle concentration was obtained every minute. A “+” in the ozone generation column indicates the presence of approximately 75 ppb of ozone in the airstream, while a “-“ indicates that there was no ozone added to the airstream. Experiments 1 & 2, 3 & 4, 5 & 6, and 7 & 8 represent paired measurement series, which were either conducted on separate filter samples cut from the same bag (Experiments 1 & 2 and Experiments 3 & 4) or on the same filter sample in both the presence and absence of ozone (Experiments 5 & 6 and Experiments 7 & 8). Both the order in which the ozone conditions occurred and the order of the two condensation nuclei particle counters in the sampling train were varied.

**Table 1.** Experimental conditions for particle concentration measurements

Experiment	Filter Sample	Ozone generation	Downstream Sampling Point (m)	Downstream particle counter
1	A	-	1.50	# 1
2	B	+	1.50	# 1
3	C	+	1.50	# 2
4	D	-	1.50	# 2
5	E	+	0.3	# 1
6	E	-	0.3	# 1
7	F	+	0.3	# 2
8	F	-	0.3	# 2

The studies were conducted at an airflow of  $1.0 \text{ L s}^{-1}$ . A new EU7 filter was inserted upstream of the filter sample in the test rig, resulting in a relatively small number of particles in the air that passed through the filter sample. The up- and downstream concentrations of submicron



particles were measured using two P-Trak Ultrafine Particle Counters (TSI Inc., Shoreview, MN, USA). The instrument utilizes condensation particle counting technology, and detects particles between 0.02 and 1  $\mu\text{m}$ . Downstream sampling occurred  $\sim 150$  cm after the filter sample for Experiments 1-4 and  $\sim 30$  cm after the filter sample for Experiments 5-8; upstream sampling was always 30 cm from the filter (see Figure 1). Up- and downstream ozone concentrations were measured simultaneously with the particle monitoring, following a procedure analogous to that described in the following paragraph.

## 2.2. Ozone removal

An UV type ozone generator was used to supply ozone-containing air directly to the intake of the test rig via a 1 cm diameter tube. The ozone concentration upstream of the filter sample was held constant at  $\sim 90$  ppb using a damper situated at the end of the tube. The up- and downstream concentrations of ozone were measured simultaneously using two cross-calibrated Dasibi model 1003 UV ozone monitors with a detection limit of 1 ppb. Ozone concentrations were monitored up- and downstream of used and new filter samples, using a small-scale test rig (Figure 2) that was slightly modified from that used for the particle measurements.

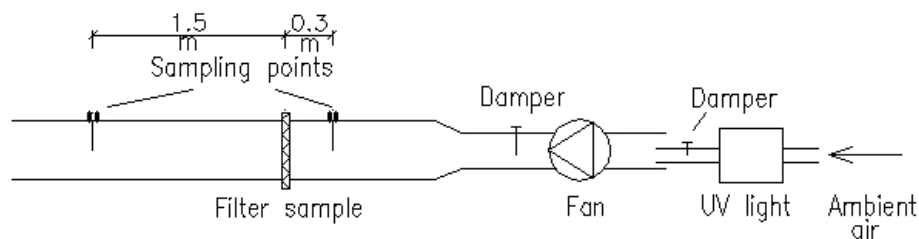

**Figure 2.** Small-scale test rig used for the ozone measurements

The studies were performed at an airflow of  $0.2 \text{ L s}^{-1}$ , corresponding to a face velocity of  $2.5 \text{ cm s}^{-1}$ . The sampling points were in the center of the duct; a fan situated between the point of ozone dosing and the ozone sampling point insured adequate mixing. The upstream sampling point was located 30 cm before the filter and the downstream sampling point was 150 cm after the filter. Each measurement series lasted until the downstream ozone concentration reached a steady-state value, approximately 1-2 hours.

### 2.2.1. Effect of time-in-service

Filters were obtained from the filter bank ( $3.0 \times 1.5$  m) of an air handling unit servicing an office building in a suburb of Copenhagen, Denmark; the system operated 5 days a week for 13 hours a day with no pre-filter in place. The filter bank contained a total of eight  $0.6 \times 0.6$  m and eight  $0.3 \times 0.6$  m EU7 filters. A new filter was substituted for a used  $0.3 \times 0.6$  m filter every 4 weeks, avoiding the corner areas of the filter bank. An added filter substitution occurred during the last two-week period. At the end of 16 weeks, these inserted filters were removed; the used filters obtained in this fashion had service times of 2, 4, 8, 12 and 16 weeks, and each of these filters had been in service during the same final two-week period. The total volume of air that had passed through the filters during these periods was between  $1.1 \times 10^5 \text{ m}^3$  for the 2-weeks-of-service filter and  $8.2 \times 10^5 \text{ m}^3$  for the 16-weeks-of-service filter. The filters were stored in separate sealed plastic bags prior to conducting the ozone removal efficiency measurements. Small samples (100 mm diameter) were cut from these filters. In

all, 8 filter samples were tested, one each from the 2, 4 and 16-weeks-of-service filters, two from the 8-weeks-of-service filter and three from the 12-weeks-of-service filter.

Additionally, in order to improve our understanding of the role of new filter material in ozone removal, three filter samples were taken from a new EU7 fiberglass bag filter that was identical in type and manufacturer to the used filters. The first sample was neither treated nor ventilated prior to the initial measurements of ozone removal efficiencies. After these measurements it was placed in a plastic bag, flushed with nitrogen and sealed. After 48 hours in the static nitrogen atmosphere, measurements of ozone removal efficiencies were repeated. A second new-filter sample was ventilated in the small-scale test rig for 48 hours with ozone-free air at a flow rate of  $0.2 \text{ L s}^{-1}$  prior to the initial measurements of ozone removal efficiencies. A third new-filter sample was ventilated for 24 hours at a flow rate of  $0.2 \text{ L s}^{-1}$  with air containing  $\sim 90$  ppb of ozone prior to the removal efficiency measurements.

### 2.2.2. Protecting a filter from ozone during its service life

Two filter samples of 100 mm diameter, cut from a new EU7 fiberglass filter identical in type and manufacturer to those used in the service life experiments (see above), were placed in separate identical arms of a small-scale manifold (Figure 3). Outdoor air passed through these filters at  $1.0 \text{ L s}^{-1}$  for the same 9 weeks. In one of the airstreams most of the ozone had been removed by adding 200 ppb of NO to the airstream approximately 7m upstream of the filter. The NO reacts with ozone at a fast rate and effectively titrates the ozone (Pollmann et al., 2005), generating molecular oxygen and nitrogen dioxide. The particle concentrations in the airstream are not altered by this procedure. The outdoor ozone concentration was not recorded during the filters' service period; however, based on measurements from a government ambient monitoring site approximately 10 km away, it reached a maximum of approximately 70 ppb during the period when the soiling of samples was conducted (summertime). Thus, two filter samples were obtained, the one soiled with particles from ambient air that contained ozone and the other soiled with particles from the same ambient air, but with the ozone removed. The ozone removal efficiencies of these two different filters were then investigated in the test rig shown in Figure 2; each series of measurements lasted  $\sim 70$  minutes.

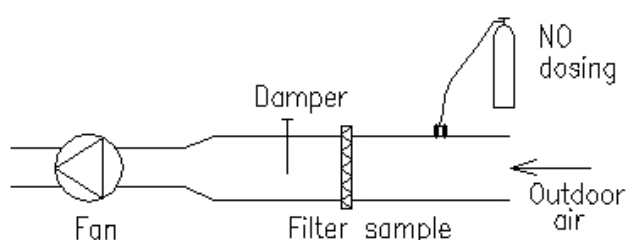

**Figure 3.** A leg of the small-scale manifold used for loading filter samples with outdoor air from which ozone had been removed by titration with nitric oxide (NO). An analogous leg, but without the NO titration, was used for loading filter samples with outdoor air that contained naturally occurring ozone

### 2.3. Data acquisition and reduction for ozone measurements

Given the air velocity in the test rig and the distance between the upstream and downstream sampling points, a parcel of air reached the downstream ozone meter  $\sim 70$  seconds after being sampled by the upstream ozone meter. The data were corrected for this lag by matching the upstream concentrations with the corresponding downstream values for each measurement.

Moreover, the first 90 to 120 seconds of each measurement series, were discarded because of the disrupted stability of the system shortly after the samples had been inserted in the test rig.

The ozone removal efficiency for a given time step ( $E_i$ ) was determined using Equation 1:

$$E_i = \frac{U_i - D_i}{U_i} \times 100 \quad [\%] \quad (1)$$

where:  $U_i$  - Upstream ozone concentration for the given time step [ppb]  
 $D_i$  - Downstream ozone concentration for the given time step [ppb]  
 $i$  - Time step

The initial removal efficiency at the beginning of each measurement series ( $E_0$ ) was based on the average of data collected during the first 90 seconds after the system achieved stability (average of 100 values recorded every 0.9 seconds). The removal efficiency at 60 minutes ( $E_{60}$ ) was calculated as the average of data collected during the last 90 seconds of the first hour of the measurement series. Where applicable, the removal efficiency at the end of the measurement series ( $E_\infty$ ) was based on the average of data obtained during the last 90 seconds.

### 3. Results

#### 3.1. Particle concentrations

Figure 4 presents particle concentrations for Experiment 1 (no ozone) and Experiment 2 (~75 ppb ozone upstream), as well as the ozone removal efficiency for Experiment 2. During the measurements the ozone removal efficiency for Experiment 2 decreased from an initial value of 65% to a final value of 12%. The average downstream to upstream ratio of particle concentrations was  $60 \pm 3\%$  when the airstream contained ozone whereas it was  $54 \pm 2\%$  when it did not. Ratios of the particle concentration downstream to the particle concentration upstream have been calculated for Experiments 1 to 8 and are shown as matched pairs in Figure 5.

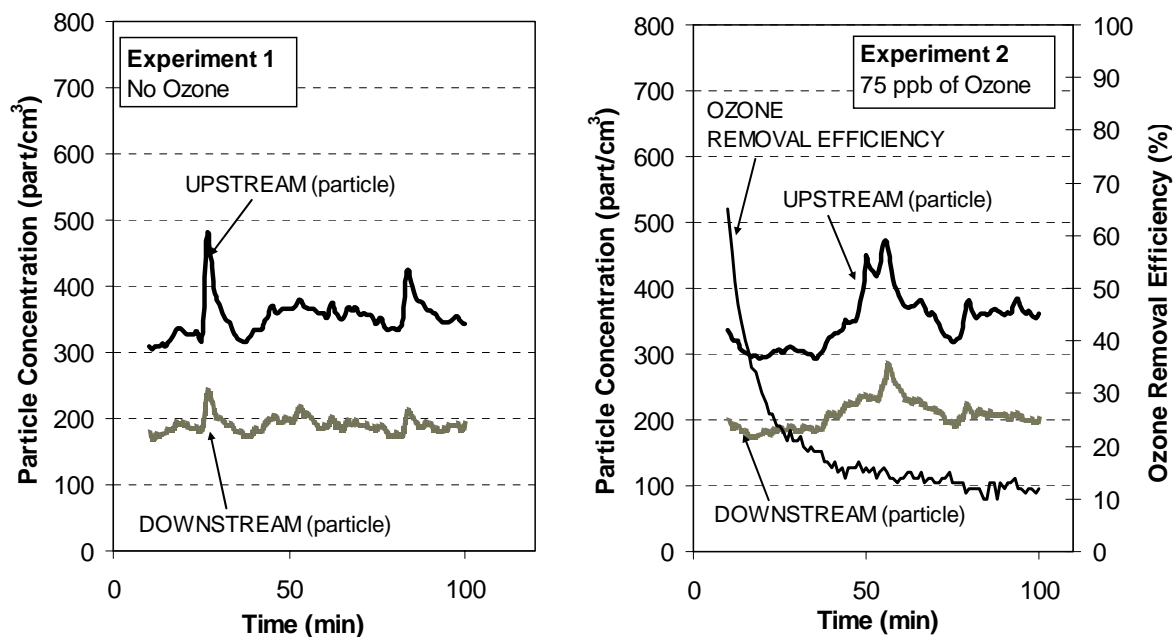

**Figure 4.** Particle concentrations (0.02 – 1  $\mu\text{m}$  diameter) upstream and downstream of a filter sample ventilated with ozone-free air (Experiment 1) and of a different sample of the same filter ventilated with air containing ozone (Experiment 2). The corresponding ozone removal efficiency (Experiment 2) is shown

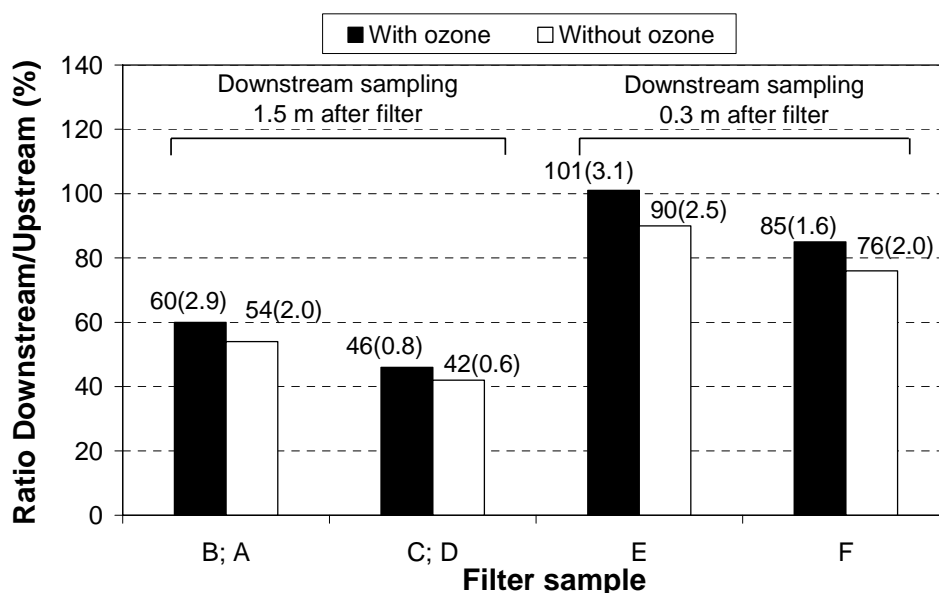
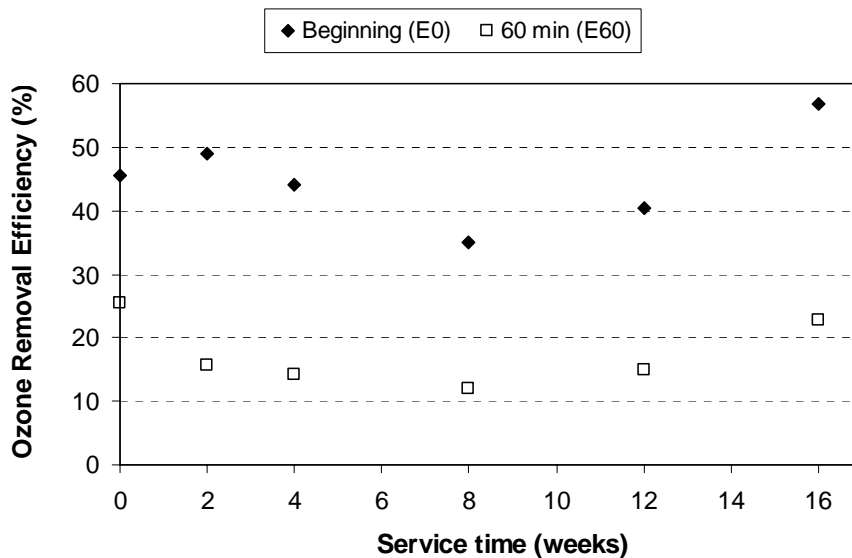

**Figure 5.** Ratios of particle concentrations (Downstream/Upstream) for Experiments 1 to 8 in Table 1. Standard deviations are indicated in parentheses

In the paired measurements, the downstream/upstream particle concentration ratios were always higher when ozone was passing through the loaded filter compared with when it was not. Significantly higher downstream/upstream values were recorded when the downstream sampling point was 30 cm from the filter (Experiments 5-8) compared with downstream sampling 150 cm from the filter (Experiments 1-4).

### 3.2. Ozone removal efficiency

Figure 6 displays the ozone removal efficiencies versus time-in-service for filters that had been soiled during different service intervals in the air handling unit of an actual building. Results are shown for the initial measurements ( $E_0$ , solid diamonds) as well as those made 60 minutes later ( $E_{60}$ , open squares). The values shown at 8 and 12 weeks-of-service are averages of two and three measurements, respectively; the remaining values are from single measurements. For each filter sample,  $E_0$  was much larger than  $E_{60}$ . However, similar changes in ozone removal efficiencies with increasing time-in-service were obtained for the  $E_0$  and  $E_{60}$  measurements. In both cases, the minimum removal efficiency was measured for filters with 8 weeks of service.



**Figure 6.** Ozone removal efficiencies versus time in service for filter samples taken from the air-handling unit of an office building in a suburb of Copenhagen, Denmark. Initial measurements (solid diamonds,  $E_0$ ) and measurements made at 60 minutes (open squares,  $E_{60}$ ) are shown

Given the surprisingly high ozone removal exhibited by the unused filter, we conducted further experiments to better define the removal of ozone by this filter. The two bars on the left in Figure 7 show the ozone removal efficiencies of a sample from the new filter that was not treated in any way and the same sample after ozone-containing air has passed through it for an hour and it had then been stored statically in nitrogen for 48 hours. The two bars on the right correspond to ozone removal efficiencies of samples after ozone-free or ozone-containing air had passed through them for 48 or 24 hours, respectively. The untreated new filter initially removed 46% of the ozone in the airstream, and, during the ensuing hour that ozone-containing air passed through the filter, the removal efficiency dropped to 25%. After being placed for 48 hours in a static nitrogen atmosphere there was little change; the filter removed 47% of the ozone in the airstream when first placed in the test rig ( $E_0$ ), decreasing to 23% after the ozone containing air had passed through the filter for an hour ( $E_{60}$ ). The sample through which ozone-free air had passed for 48 hours prior to evaluation demonstrated lower ozone removal ( $E_0 = 21\%$  and  $E_{60} = 12\%$ ) than the untreated sample. The removal efficiency was even lower (8%) for the sample through which ozone-containing air had passed for 24 hours; an additional hour of filtering ozone-containing-air had no effect on the removal efficiency (i.e.,  $E_0 = E_{60}$ ).

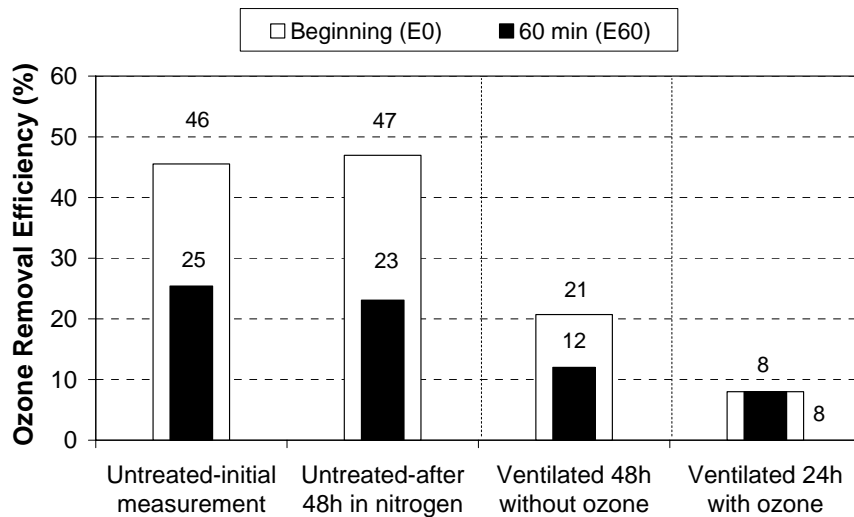

**Figure 7.** Ozone removal efficiencies of an untreated and two differently ventilated new filter samples. After the initial measurement series the untreated filter sample was statically exposed to nitrogen for 48 h before re-evaluation. Initial measurements ( $E_0$ ) and measurements made at 60 minutes ( $E_{60}$ ) are shown

Figure 8 compares the ozone removal efficiencies of two filter samples, one soiled with particles from ambient air that contained ozone and the other soiled with particles from the same ambient air, but with the ozone removed. When first placed in the test rig, the sample that had been protected from ozone had a removal efficiency of 28% while the unprotected sample had a removal efficiency of 23%. Similar differences between the two filters were measured at 60 and 70 minutes.

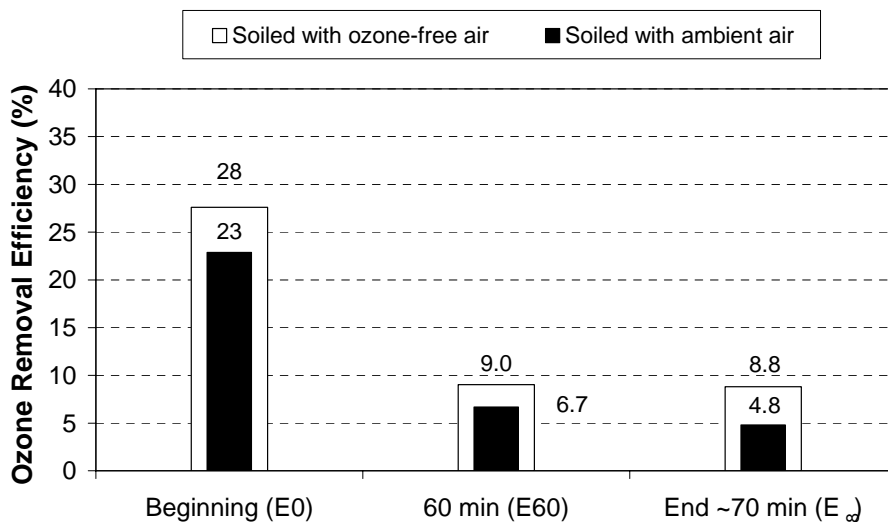

**Figure 8.** Ozone removal efficiencies of the two 9-weeks-of-service filter samples, one soiled with ambient air containing ozone and the other simultaneously soiled with the same ambient air from which ozone had been removed (see text for details). Initial measurements ( $E_0$ ), and measurements made at 60 minutes ( $E_{60}$ ) and at the end ( $E_\infty$ ) of the evaluations are shown

## 4. Discussion

### 4.1. Particles as indicators of oxidation processes on filter surfaces

Particle concentrations upstream and downstream of the filter samples were quite low, reflecting prior filtration of the air using a new filter (Figure 1). These very low particle concentrations immediately upstream of the soiled filter samples allowed small differences in particle concentrations to be detected downstream of the soiled filters.

The particle removal efficiencies of filter samples obtained from the experiments with ozone present in the airstream were always lower than those for the matching experiments conducted without ozone in the airstream (Figure 5). We suggest that these apparent changes in removal efficiencies are due to the growth of particles downstream of the soiled filter samples (ozone is not expected to alter a filter's ability to remove particles). Presumably, when ozone passes through a loaded filter, oxidation occurs on the filter surface. Subsequently, the low vapor-pressure oxidation products desorb from the filter and partition between the gas phase of the airstream and particles in the airstream. Such processes will result in accretion and growth of the particles that have passed through the sample filter. As a consequence, particles that had been too small to be counted by the particle counter (smaller than 20 nm in diameter) grow in diameter up to and beyond the point where they become "countable". Changes in particle number concentrations can be a sensitive indicator of changes in the concentrations of low volatility organic compounds in an airstream. The accretion of less than a  $\text{ng}/\text{m}^3$  of semi-volatile oxidation products on particle surfaces can result in detectable changes in particle number concentrations using a condensation nuclei counter similar to that used in the current study.

The downstream/upstream ratios were significantly higher when the downstream sampling point was 30 cm downstream from the filter sample (right set of bars in Figure 5) compared with when it was 150 cm downstream from the filter (left set of bars in Figure 5). This presumably reflects loss of particles to the surfaces of the ductwork as the air flows through the test rig.

Gas-phase reactions between ozone and certain higher molecular weight unsaturated organic compounds (e.g. terpenoids) in the indoor environment are known to significantly increase the mass concentration of secondary organic aerosols (Weschler and Shields, 1999; Weschler, 2003 and references therein). In a similar fashion, reactions occurring on the surface of a loaded filter appear to have resulted in the growth of airborne particles downstream of used ventilation filters. However, the observed increase in downstream particle concentrations resulting from ozone in the airstream is orders of magnitude smaller than that resulting from gas-phase ozone/terpenoid reactions at realistic precursor concentrations and is anticipated to have a negligible impact on human health.

### 4.2. Ozone removal by ventilation filters

#### 4.2.1. Influence of time-in-service

The new filter evaluated in this study initially removed about 45% of the ozone from the airstream; after one hour of operation it still removed 25% of the ozone; and, after 48 hours in a nitrogen atmosphere, it regained its original ozone removal efficiency (1<sup>st</sup> and 2<sup>nd</sup> bars in Figure 7). When ozone-containing air had passed through the new filter for 24 hours, its

ozone removal efficiency was reduced to 8%, and this value did not change through the subsequent hour of measurements (4<sup>th</sup> bar in Figure 7). This residual ozone removal may be due to catalytic destruction of ozone as discussed in Bekö et al. (2006). These results contrast with our previous measurements of a different new fiberglass EU7 bag filter that removed only 10% of the ozone at an airflow of 0.2 L s<sup>-1</sup>; 2% of the ozone at an airflow of 1.0 L s<sup>-1</sup>; and whose ozone-removal efficiency did not vary with time in the test rig. These contrasting results obtained with two different unused EU7 filters are consistent with findings recently reported by Hyttinen et al. (2006). They found that an unused G3 polyester pre-filter did not remove ozone; one type of unused fiberglass F8 filter removed an average of 6% during the first hour; and another type of unused fiberglass F8 filter removed an average of 19% during the first hour and regained its removal efficiency after a 16-18 hour break in ozone exposure. Taken together, these findings show that ozone removal properties of new filters vary by manufacturer and filter type. The impact of ozone removal on air quality downstream of new or slightly used filters remains to be determined.

Measurements of ozone concentrations upstream and downstream of filter samples that had been in service for between 2 and 16 weeks confirm earlier findings that used ventilation filters remove ozone from the airstream (Hyttinen et al., 2003, 2006; Bekö et al., 2006; Zhao et al., 2005). This removal is likely to depend on the age and/or amount of particulate matter retained by the filter. In the experiments with filters that had been in service for periods up to 16 weeks (Figure 6), the 8 weeks-of-service filter samples exhibited, on average, the lowest ozone removal efficiency when first placed in the test rig; this remained the case when comparing results obtained for samples after 60 minutes in the test rig. The 12 and 16 weeks-of-service filters removed more ozone from the air passing through them than the 8 week filter. This is consistent with the increasing number of captured particles and associated organic compounds for the 12 and 16 week filters. As noted above, relatively high ozone removal efficiencies were obtained for the unused filter. This was also true for filters with 2 and 4 weeks of service (see Figure 6). We assume that different processes are responsible for the high initial ozone removal of the unused or slightly used filters and the filters that had been in service for a substantial period of time. In the first case, the ozone likely reacts with organic compounds remaining on the surface of the filter after the manufacturing process (e.g., tackifiers, binders, resins). Such compounds also appear to be present within the filter material, since an unused filter can regain its ability to remove ozone when left in a static environment (2<sup>nd</sup> bar, Figure 7). In contrast, organic compounds associated with the captured particles are likely the main cause of ozone removal by older filters.

The influence of the organic compounds responsible for the ozone removal of a new filter would be anticipated to diminish with increasing time of use; some of these compounds would desorb into the air passing through the filter (3<sup>rd</sup> bar in Figure 7), some of these compounds would be consumed through reaction with ozone (4<sup>th</sup> bar in Figure 7), and others would be masked from ozone by the captured particles. On the other hand, the contribution of captured particles to ozone removal is anticipated to increase with time (Hyttinen et al., 2006). The combination of these processes could result in a trend in overall ozone removal over time similar to that observed in Figure 6. However, the trend shown in Figure 6 should be interpreted cautiously. Two samples taken from the same bag filter with 8 weeks-of-service had significantly different ozone removal efficiencies (26 vs. 44% initially; 6 vs. 18% after 1 hr). Three samples taken from the same bag filter with 12 weeks-of-service also had different ozone removal efficiencies (48 vs. 43 vs. 30% initially; 17 vs. 15 vs. 13% after 1 hr). The different measurements for samples from the same loaded bag filter are assumed to be due to differences in the loading and accumulation of the “filter cake” throughout a filter bag.



That is, as is apparent from visual inspection, the captured particles are not distributed evenly across the surface of a filter.

#### *4.2.2. Influence of ozone exposure during time in service*

The filter that had been protected from ozone during its nine weeks of service subsequently removed more ozone in the test rig than the filter that had not been protected from naturally occurring ozone during its identical nine weeks of service. This was true for the initial, 60 min and final measurements (Figure 8), and is consistent with expectations. When air flows through a filter, the filter captures airborne particles and associated organic compounds, including some that can react with ozone. If the air contains reduced amounts of ozone, less oxidation will occur on the filter surface, “saving” a fraction of reactive organics for future reaction with ozone. This result suggests that a used filter’s previous exposure history will influence the extent to which it reacts with ozone in the present.

### **5. Conclusion**

Previous studies (Bekö et al., 2003; 2006; Hytinen et al., 2003, 2006; Zhao et al., 2005) have demonstrated that oxidation processes can change the mix of chemicals in the air downstream of a loaded filter, and may result in less acceptable ventilation air. The results from the particle measurements provide circumstantial evidence for the formation of semi-volatile oxidation products as the loaded ventilation filters scavenge ozone. The increase of secondary organic aerosols observed downstream of the filter when ozone is present in the airstream is not, in itself, of great concern. The observation, however, provides further evidence that ozone initiates oxidation processes on the surface of loaded filters, and that the oxidation products are not exclusively volatile compounds such as formaldehyde and C<sub>5</sub>-C<sub>10</sub> aldehydes, but include semi-volatile compounds. This is consistent with the spectrum of unsaturated compounds associated with the captured particles, including sesquiterpenes and unsaturated fatty acids that react with ozone to yield higher molecular weight, low vapor pressure products. Some of these products are expected to desorb and subsequently partition between the air and particles in the air, leading to an increase in countable particles, as has been observed in this study.

In the present comparison of filters from the same filter bank, both relatively new filters and filters with four months of service were found to remove more ozone than those with two months of service. For new and slightly used filters ozone removal appears to be dominated by organics remaining on the filter following manufacturing. For older filters (e.g., four months of service) ozone removal appears to be dominated by organics associated with captured particles. In a related set of experiments, continuous removal of ozone from the air passing through a filter during its time-in-service increased its subsequent ozone removal efficiency relative to a filter in simultaneous and equivalent service, but without protection from ozone. Hence, the extent to which ozone reacts as it passes through a loaded filter depends, among other factors, on the time the filter has been in service and the ozone it has previously experienced during service.

This study provides further evidence for the regeneration of a filter’s ozone removal efficiency after a break in ozone exposure. This and previous studies indicate that when a filter is in continuous service, the formation and subsequent off-gassing of oxidation products is much smaller than when a filter initially returns to service after a break in operation. As a

corollary, when a filter has operated for weeks or months during which the ozone passing through it has been extremely low (e.g., during winter months), the first day when air with significant quantities of ozone passes through it (e.g., the first high ozone day of spring), will be a day with higher generation and off-gassing of oxidation products. These facts have implications for the day-to-day operation of HVAC systems, especially in regions of the world that routinely experience high outdoor ozone levels.

## Acknowledgements

This work has been supported by the Danish Technical Research Council (STVF) as part of the research program of the International Centre for Indoor Environment and Energy established at the Danish Technical University for the period 1998-2007. The authors thank Oto Halás and Gyöngyi Tamás for their assistance with the particle measurements and associated data processing. Thanks are due to Wojciech Obtulowicz for his help with preparation of the filter samples.

## References

- Bekö, G., Halás, O., Clausen, G., Weschler, C.J., Toftum, J., 2003. Initial studies of oxidation processes on the filter surfaces and their impact on perceived air quality. *Proceedings of Healthy Buildings 2003*, Singapore, Vol. 3, 156-162.
- Bekö, G., Halás, O., Clausen, G., Weschler, C.J., 2006. Initial studies of oxidation processes on filter surfaces and their impact on perceived air quality. *Indoor Air*, 16, 56-64.
- Clausen, G., Alm, O., Fanger, P.O., 2002. The impact of air pollution from used ventilation filters on human comfort and health. *Proceedings of the 9<sup>th</sup> International Conference on Indoor Air Quality and Climate*, Indoor Air 2002, Monterey, USA, Vol. 1, 338-343.
- Clausen, G., 2004. Ventilation filters and indoor air quality: a review of research from the International Centre for Indoor Environment and Energy. *Indoor Air*, 14, S7, 202-207.
- Hyttinen, M., Pasanen, P., Kalliokoski, P., 2001. Adsorption and desorption of selected VOCs in dust collected on air filters. *Atmospheric Environment*, 35, 5709-5716.
- Hyttinen, M., Pasanen, P., Salo, J., Björkroth, M., Vartianen, M., Kalliokoski, P., 2003. Reactions of ozone on ventilation filters. *Indoor and Built Environment*, 12, 151-158.
- Hyttinen, M., Pasanen, P., Kalliokoski, P., 2006. Removal of ozone on clean, dusty and sooty supply air filters. *Atmospheric Environment*, 40, 315-325.
- Klenø Nøjgaard J.G., Christensen K.B., Wolkoff P., 2005. The effect on human eye blink frequency of exposure to limonene oxidation products and methacrolein. *Toxicology Letters*, 156, 241-251.
- Morrison, G.C., Nazaroff, W. W., Cano-Ruiz, J. A., Hodgson, A. T., Modera, M. P., 1998. Indoor air quality impacts of ventilation ducts: ozone removal and emissions of volatile organic compounds. *Journal of the Air and Waste Management Association*, 48, 941-952.
- Pasanen, P., Teijonsalo, J., Seppänen, O., Ruuskanen, J., Kalliokoski, P., 1994. Increase in perceived odor emissions with loading of ventilation filters. *Indoor Air*, 4, 106-113.
- Pasanen, P., 1998. Emissions from filters and hygiene of air ducts in the ventilation systems of office buildings. Doctoral dissertation, Kuopio University Publications C. Natural and Environmental Sciences 80, 1-77.
- Pejtersen, J., Bluyssen, P., Kondo, H., Clausen, G., Fanger, P.O., 1989. Air pollution sources in ventilation systems. *Proceedings of CLIMA 2000*, Sarajevo, August 1989, Vol. 3, 139-144.

- Pejtersen, J., 1996. Sensory pollution and microbial contamination of ventilation filters. *Indoor Air*, 6, 239-248.
- Pollmann, J., Ortega, J. Helmig, D., 2005. Analysis of atmospheric sesquiterpenes: sampling losses and mitigation of ozone interferences. *Environmental Science and Technology*, 39, 9620-9629.
- Tamás, G., Weschler, C.J., Toftum, J., Fanger, P.O., 2006. Influence of ozone-limonene reactions on perceived air quality. *Indoor Air*, 16, 168-178.
- Wargocki, P., Wyon, D.P., Fanger, P.O., 2004. The performance and subjective responses of call-centre operators with new and used supply air filters at two outdoor air supply rates. *Indoor Air*, 14, S8, 7-16.
- Weschler, C.J., Shields, H.C., 1999. Indoor ozone/terpene reactions as a source of indoor particles. *Atmospheric Environment*, 33, 2301-2312.
- Weschler, C.J., 2000. Ozone in indoor environments: Concentration and chemistry. *Indoor Air*, 10, 269-288.
- Weschler, C. J., 2003. Indoor chemistry as a source of particles. in *Indoor Environment: Airborne Particles and Settled Dust*, edited by Morawska, L. and Salthammer, T. pp. 171-194, Wiley-VCH, Weinheim.
- Weschler, C.J., 2004. Chemical reactions among indoor pollutants: what we've learned in the new millennium. *Indoor Air*, 14, S7, 184-194.
- Wolkoff, P., Nielsen, G.D., 2001. Organic compounds in indoor air – their relevance for perceived indoor air quality?. *Atmospheric Environment*, 35, 4407-4417.
- Wyon, D.P., Tham, K.W., Croxford, B., Young, A., Oreszczyn, T., 2000. The effects on health and self-estimated productivity of two experimental interventions which reduced airborne dust levels in office premises. *Proceedings of Healthy Buildings 2000, Espoo, Vol. 1*, 641-646.
- Zhao, P., Siegel, J.A., Corsi, R.L., 2005. Ozone removal by residential HVAC filters. *Proceedings of 10th International Conference on Indoor Air Quality and Climate, Indoor Air 2005, Beijing, China*, 2366-2370.

**4.3 Is the use of particle air filtration justified? Costs and benefits of filtration with regard to health effects, building cleaning and occupant productivity**

**Paper to be published in:**  
Building and Environment

**Publisher:**  
Elsevier

**Paper submitted on:**  
28 February, 2007

# **Is the use of particle air filtration justified? Costs and benefits of filtration with regard to health effects, building cleaning and occupant productivity**

Gabriel Bekö <sup>a, b</sup>, Geo Clausen <sup>b</sup>, Charles J. Weschler <sup>b, c</sup>

<sup>a</sup> Faculty of Civil Engineering, Department of Building Services, Slovak University of Technology, Radlinského 11, 813 68 Bratislava, Slovakia

<sup>b</sup> International Centre for Indoor Environment and Energy, Department of Mechanical Engineering, Technical University of Denmark, Nils Koppels Allé, Building 402, DK-2800 Lyngby, Denmark

<sup>c</sup> Environmental and Occupational Health Sciences Institute, UMDNJ-Robert Wood Johnson Medical School & Rutgers University, Piscataway, NJ 08854 USA

Corresponding author:

Gabriel Bekö  
International Centre for Indoor Environment and Energy  
Technical University of Denmark  
Nils Koppels Alle, Building 402  
DK-2800 Lyngby, Denmark  
Phone: (+45) 45 25 40 18, fax: (+45) 45 93 21 66  
E-mail: gb@mek.dtu.dk

## **Abstract**

Estimates of costs and the corresponding benefits of particle filtration have been derived for a standard office building. Reduction in occupants' exposure to particles during their workday is anticipated to reduce their morbidity and mortality. Filtration may also reduce the costs associated with building and HVAC cleaning. Conversely, losses of occupant productivity due to sensory offending pollutants emitted from used ventilation filters can lead to significant economic losses. The results of the present analysis are strongly dependent on several key input parameters; consequently, the sensitivity of the results to these parameters was tested as part of this study. The study also acknowledges that the benefits-to-costs ratio depends on the perspective of the stakeholder: the employer renting the building is impacted by occupant performance and building energy costs; the building owner is impacted by maintenance of the building and its HVAC system; society is impacted by the employees' health and welfare. Regardless of perspective, particle filtration is anticipated to lead to annual savings significantly exceeding the direct costs for filtration. However, economic losses resulting from even a small decrease in productivity caused by sensory pollutants emitted from used ventilation filters have the potential to substantially exceed the annual benefits of filtration. Further studies are required to determine if meaningful benefits can be obtained from more frequent filter replacement or application of different filtration technologies that limit the emission of offending pollutants from the particles that have been removed from the ventilation air.

## **Key words**

Cost-benefit evaluation, Particle filtration, Used filters, Productivity, Morbidity, Mortality

## **1. Introduction**

Numerous epidemiological studies [1-4] have reported associations between outdoor airborne particles and both morbidity and mortality. The CAFÉ (Clean Air for Europe) group acting within the European commission has concluded that for particles with diameters smaller than either 10  $\mu\text{m}$  (PM10) or 2.5  $\mu\text{m}$  (PM2.5), a safe concentration is unlikely to exist [5]. PM2.5 are of particular concern [6,7]. Most of our exposure to such particles occurs inside buildings. Although there are indoor sources of particles [8,9], outdoor air is a significant and often dominating source of indoor particles, especially in mechanically ventilated structures such as offices and schools [10-12]. In such premises supply air filters reduce the outdoor-to-indoor transport of particles and the consequent concentration of indoor particles of outdoor origin [12-15]. A recent European standard [16] focuses on achieving a healthy indoor environment by specifying requisite filter performance taking into consideration the particle levels in outdoor air.

Air filtration has the potential to significantly reduce disease transmission, allergies and asthma, Sick Building Syndrome (SBS) symptoms and, thus, productivity loss. This has been examined by Fisk and Rosenfeld [17]. Based on their analysis, when the filtration system in an office building is upgraded with more efficient filters, the financial benefits resulting from an improved indoor environment may exceed the costs of filtration by as much as a factor of twenty. Improved particle filtration can also be cost-effective in terms of reduced failures in telephone switching and computing equipment [18]. Additional benefits may accrue from the protection of the individual components of HVAC systems, which is often the primary reason

filtration systems are installed. On the other hand, there are costs associated with the use of ventilation filters. Air handling systems often consume a large portion of a building's energy need, and the pressure drop across particle filters can significantly contribute to the total pressure drop and energy consumption of a system [19]. Although more efficient filters have higher energy penalties and total costs, these tend to be negligible relative to salaries, rent or health insurance costs [14].

When designing a filtration system, it is important to take into consideration all financial aspects associated with its life cycle. One factor that has been neglected in previous economic evaluations of filtration is the potential release of sensory pollutants from used filters. Loaded filters have been found to be a serious source of sensory pollutants [20-23], with the potential to contribute to symptoms characteristic of sick building syndrome (SBS) [24] and a consequent decrease in occupant performance [25,26]. Even a small decrease in productivity leads to meaningful economical losses. Hence, the benefits of air filtration may be somewhat countered by the effects of pollutants entering ventilation air as it passes through dirty filters.

The purpose of the present paper is to present a broader evaluation of the economic costs and benefits of standard particle filtration. We recognize that for many of the parameters in this evaluation, the available input data are imprecise and limit the accuracy of the resulting estimates. However, our intent is to provide a broad sense of the more important parameters affecting aggregate costs and benefits associated with building air filtration, leading to more informed decisions when choosing a filtration strategy.

## **2. Approach**

A standard office building was used as the setting for the following estimates of economic costs and corresponding benefits of a single-pass particle filtration system. We started with the assumption that the building contained 1000 occupants; the size of the building and the air handling system was then determined based on a design criteria of 10 L/s/occupant of outdoor supply air and an occupant density of 14.3 m<sup>2</sup>/occupant [27]. The resulting total airflow, absent recirculation, is 10 m<sup>3</sup>/s. Operating without recirculated air is typical in northern Europe and was chosen to keep the model relatively simple. The potential influences of recirculation on the costs and benefits of filtration are presented in the Discussion section.

We assumed yearly replacement of F7/EU7 filters. This filter efficiency is the minimum recommendation of EN13779 [16] for one-pass filtration. The reference condition in the present analysis was an identical building with no filtration system. Evaluations of changes in filter efficiency on the economic outcomes were not included in the current study and are intended to be part of a future analysis.

The direct costs associated with air filtration include both initial costs and annual running costs. An indirect cost is lost productivity due to SBS symptoms caused by pollutants from soiled filters. The potential benefits of filtration include improved health as has been previously recognized by Fisk [14]. Lower indoor levels of particles that originated outdoors are anticipated to result in reduced morbidity and mortality for buildings occupants. An additional benefit of filtration is a decreased soiling rate and less frequent cleaning. In the present analysis cleaning of the occupied space and cleaning of the HVAC ducts have been considered, however soiling-related changes in the energy efficiency of heat exchangers have

not. Other factors that have not been considered in the present analysis include taxes, insurance and the environmental impact of filter disposal.

The results of the analysis have been expressed in 2005 US dollars per standard year, calculating with a yearly discount rate of 3%, where applicable. The standard year assumes that no additional investments have to be made for obtaining and installing a new ventilation/filtration system (i.e., adding a filter rack or auxiliary equipment). Additionally, the results have been normalized in US dollars per occupant. Some of the input parameters are imprecise and thus are sources of uncertainty. Therefore, where possible, we have performed parametric investigations within a relevant range of the input parameters. The basic input data used for the calculations are listed in Table 1.

**Table 1. Input data used in the analysis**

Parameter	Assumed value
Total building ventilation rate	10 m <sup>3</sup> /s
Outdoor air supply rate per occupant*	10 L/s/person
Occupancy*	0.07 occupant/m <sup>2</sup>
Number of occupants	1000
Floor area of building	14,300 m <sup>2</sup>
Average annual outdoor PM10 level	30 µg/m <sup>3</sup>
HVAC operating hours	3000 hours/yr (=12hrs/day, 250 days/yr)
Occupants' time at work	8 hours/day; 250 days/yr
Face velocity in HVAC unit	2.5 m/s
Initial pressure drop across filters	100 Pa
Final pressure drop across filters	200 Pa
Fan total efficiency	70 %
Motor efficiency	65 %
Cost of electricity	\$0.15 /kWh
Filter life	3,000 hrs
Average daily salary per occupant***	\$184
Average annual salary per occupant***	\$46,000
Discount rate	3%

\* from CEN CR 1752 [27]

\*\* PM10 of outdoor origin

\*\*\* based on the average hourly office worker salary in the US in 2005, which was \$23 [28].

### 3. Methods and results

#### 3.1. Estimate of costs

The costs associated with a filtration system include the initial purchase of the filters, racks and fans, as well as the annual costs for energy and maintenance. Filtration housings can be included in central air handling units for a relatively small incremental price. Moreover, the life span of an air handling unit can be up to several decades. If we were to spread the first cost of a filter box over its entire lifetime and include it in the annual costs, we would obtain an entry that is negligible compared with other costs in this analysis. For similar reasons we have not included the incremental cost of a larger central air unit to handle the increased static pressure due to the presence of filters as well as increased cooling coil capacity to address additional heat from the larger air handler. We have simply focused on the annual running costs and compared them with the annual benefits. The annual running costs associated with



fibrous bag filters include their replacement (new filters, labor, disposal of old filters) and power consumption resulting from the energy needed to move air through the filters.

We have assumed that the building in this analysis uses 0.6 x 0.6 meter EU7 bag filters. Given the total air flow rate and the 2.5 m/s face velocity of air passing through the filters, we calculated the cross-sectional area of the filter bank (4m<sup>2</sup>) and, thus, the number of filters needed (11 filters). We adjusted this number to a value that was consistent with a realistic filter bank (12 filters). The cost input data were taken from Camfil Farr's publicly available Life Cycle Cost software [29], which is based on the Eurovent document [30]:

- Cost of filter: \$80 /filter
- Labor for filter replacement: \$12 /filter
- Filter disposal: \$5 /filter

The power consumption needed to overcome the pressure drop across the installed filters increases as the filters become more loaded. The pressure drop is anticipated to increase exponentially, however the deviation from a linear relationship is small until the pressure drop reaches approximately double its initial value [31]. Hence, the average pressure drop over the filter's lifetime was determined from a linear approximation of the pressure drop increase over time. The life span of the filters as well as their initial and final pressure drop, were estimated according to Hangström [32] for an urban environment. From the corresponding air power (airflow rate multiplied by average pressure drop) and the given fan and motor efficiencies, the required fan power (air power divided by total fan and motor efficiency) was calculated. Finally the price of power consumption per filter lifetime was obtained (fan power multiplied by operating hours and electricity price).

For the type of comparison we are trying to make in this paper, it is sufficient if the annual cost of air filtration (Table 2) represent one time/one year estimates in 2005 prices. We judge it to be an unnecessary refinement to determine an average of all annual expenses over a longer time period (HVAC system lifetime) corrected to the present value through the respective discount rate.

**Table 2.** Annual costs of air filtration (fibrous bag-filters)

Item	Cost (\$/yr)
Energy	1,480
Replacement – filter	960
Replacement – labor	140
Disposal	60
<i>Total</i>	<i>2,640</i>
<i>Total per occupant</i>	<i>2.64</i>

### 3.2. Estimate of benefits

#### 3.2.1. Health endpoints

Numerous studies have demonstrated associations between particulate air pollution and adverse health effects, including both morbidity and mortality (see WHO [33]; Pope [3]). Earlier epidemiological studies were based on data from PM10 monitoring stations, while more recent epidemiological studies have focused on PM2.5 data following U.S. implementation in 1997 of the PM2.5 National Ambient Air Quality Standard (see Dominici [4] and references therein). Nonetheless, the coarse fraction (PM2.5–PM10) also appears to

contribute to both morbidity and mortality [5]. The present study addresses particles smaller than 10  $\mu\text{m}$  diameter (PM10), since fibrous filters are more efficient in removing coarse particles than fine particles.

Standards currently in place in North America and Western Europe for the annual average outdoor concentration of PM10 lie between 30 and 60  $\mu\text{g}/\text{m}^3$  [34]. Although the new WHO air quality guideline for the annual mean concentration of particulate matter recommends 20  $\mu\text{g}/\text{m}^3$  [7], only about 30% of the urban population worldwide experience annual PM10 concentrations smaller than this value [34]. We decided to use 30  $\mu\text{g}/\text{m}^3$  for our value of annual average outdoor PM10 concentration, recognizing that more than 70% of the people living in North American and Western European cities experience average annual concentrations smaller than this.

The determination of the concentration of indoor PM10, with and without filtration, requires several estimates. Indoor particles come from both outdoor and indoor sources. Particles that originate outdoors are removed by ventilation-system filters and by deposition onto indoor surfaces [35]. These loss processes depend strongly on particle-size and vary with building design and operation.

The current analysis assumes that indoor sources such as smoking and other combustion processes (e.g., cooking) are not present. In today's office-type buildings, this is usually the case. Nor are the effects of particle resuspension on various health outcomes included in the current analysis. Since the epidemiological literature focuses on associations between outdoor particles and health consequences, we have focused on the "indoor proportion of outdoor particles" (IPOP) as defined by Riley [10]. These authors calculated IPOP for two office-building scenarios (with 40% and 85% ASHRAE filters). Jamriska [15] also modeled the effect of ventilation rate and air filtration on the concentration of indoor particles for several indoor/outdoor scenarios likely to occur in mechanically ventilated buildings. Based on these two studies, we estimated the annual average indoor PM10 concentration without particle filtration to lie between 65% and 95% of the outdoor PM10 level. For three conditions (65%, 80% and 95%), we conducted parametric investigations of the impact of reduction of indoor PM via filtration on various health outcomes. For these evaluations we assumed that removal efficiencies remained unchanged throughout a filter's lifetime. This is a conservative assumption since removal efficiencies tend to increase as a filter loads.

Cohort and cross sectional studies have found associations between particle levels measured over a period of a year or more and mortality. We have used results from such studies as the basis for our estimates instead of results from studies that focus on acute particle exposures. Regarding morbidity, health effects were evaluated for the following: respiratory hospital admissions, asthma related emergency room (ER) visits, minor restricted activity days and work loss days. Other health and welfare benefits were excluded due to the inability to appropriately monetize them and to avoid double counting.

Most studies express the health effects as a function of a measured change in air pollutant levels. The calculation of the corresponding relative risk of health impact depends on the concentration-response (C-R) functions from epidemiological studies. Some studies assume a linear relationship for the C-R function, while others use log-linear functions [36]. We have based our estimates on the generally accepted linear dose-response model. Hence, any exposure reduction leads to a proportionate reduction in PM-induced mortality and other health effects [12,34].

### 3.2.1.1. Premature mortality

The baseline incidence rate is the number of cases of the health effect per year in the assessment location corresponding to baseline pollutant levels in that location [37]. The US national average baseline incidence rates for non-accidental mortality by age-group were taken from a CDC compressed mortality file [38] as described in Hubbell [37]. The population-weighted average mortality rate per 100 people per year for the 20-64 years age group was determined using the US census population data for the year 2000 [39]. Such an approach assumes that the building occupants represent the age-specific population stratification in the presently assumed range of workforce age (20-64 years). For this group, the average annual mortality rate was 0.29 deaths/100 people.

Most of the recent epidemiological studies estimate a C-R function for the health effects of fine particles – PM<sub>2.5</sub> [1,2,3]. The 1999 U.S. EPA Report to Congress on the Benefits and Costs of the Clean Air Act [40] and numerous other evaluations use a C-R coefficient of 6.6% (i.e., an increase in mortality rates of 6.6% for a 10 $\mu\text{g}/\text{m}^3$  increase of PM<sub>2.5</sub>) taken from the American Cancer Society study [2], which was based on a large sample size and extensive geographic coverage. The translation of the C-R coefficient for PM<sub>2.5</sub> to one for PM<sub>10</sub> depends, among other factors, on the ratio of PM<sub>2.5</sub> to PM<sub>10</sub>. Available measurements indicate that this ratio ranges from 0.5 to 0.8 in many urban areas in developed countries (see Cohen [34]). Cifuentes [41] used a 3.5% increase in relative risk for a 10 $\mu\text{g}/\text{m}^3$  increase in PM<sub>10</sub>; this value was derived from the results of the Pope [2] study for PM<sub>2.5</sub>. Similarly, using the Pope [2] study, Cesar [36] derived a C-R coefficient of 3.8% increase in mortality rates for each 10 $\mu\text{g}/\text{m}^3$  increase of PM<sub>10</sub>. We have based our calculations on the latter value.

The decline of annual mortality rate in the currently analyzed standard office building with filtration and 1000 occupants would be  $(\mu\text{g}/\text{m}^3 \text{ indoor PM}_{10} \text{ decrease} / 10\mu\text{g}/\text{m}^3) \times 0.0384 \text{ C-R function} \times (0.29 \text{ deaths} / 100 \text{ people per year}) \times 1000 \text{ occupants}$ . The period that the occupants spend in the filtration-protected environment is limited to their working hours. The results for the health effects were therefore corrected by a factor of 0.228 ((8 work hours / 24) x (250 work days / 365)), based on a linear C-R correlation.

To estimate of the economic value of reductions in air pollution-related premature mortality, we have used a methodology referred to as the “Value of Statistical Life-Years” or VSLY [40]. In this approach, age-specific life expectancy and death rates are taken into account together with the age distribution and size of the exposed population to estimate the average number of years of life lost per death (YLL). YLL per death was calculated from the WHO World Health Report 2002 [33] for the AMR-A sub-region, which includes Canada, United States and Cuba. The YLL attributable to urban air pollution (152,000) divided by the corresponding mortality (28,000) results in 5.4 years of life lost per death. Hence, the number of saved life years in the hypothetical office building is calculated as the decline in mortality multiplied by number of years of life lost per death. (Note that the YLL and mortality values obtained from WHO [33] are representative of the sub-region’s entire population. Uncertainty may be encountered due to the fact that the present study is limited to a specific age group. Less premature deaths occur and more years of life are lost per death among people between 20-64 years of age than among older citizens).

There are several ways to assign a dollar value to premature mortality. One of them is by the associated decrease in earnings - the human capital approach. The value of a person’s expected future earnings lost when a person dies prematurely (the human capital measure) is a narrow definition of benefits and tends to underestimate the economic value of premature

mortality. “Willingness to pay” (WTP) is an economic measure that is considered more comprehensive than the human capital approach. It estimates the amount that people are willing to pay to reduce the risk of dying or losing a year of life. Ideally, WTP should capture the loss in satisfaction - from consumption, leisure time, interaction with friends and family - that occurs when life is shortened. However, such approach to benefit valuation reflects the employee’s perspective and is not representative of the party (building owner or employer) directly burdened by the costs of filtration.

In the present study, the value of avoided premature mortality was calculated via i) human capital losses (HCL), calculated as the number of saved life years multiplied by the annual salary and ii) willingness to pay to avoid a lost year of life, calculated as the number of saved life years multiplied by the value of a statistical life year (VSLY=\$457,000 [40], adjusted with 3% discount rate to 2005 dollars). The fact that premature death is more likely to occur among more senior personnel who tend to have higher salaries was disregarded in the present study. The results for the various annual average indoor PM10 concentrations with and without filtration are summarized for the two valuation methods in Figure 1.

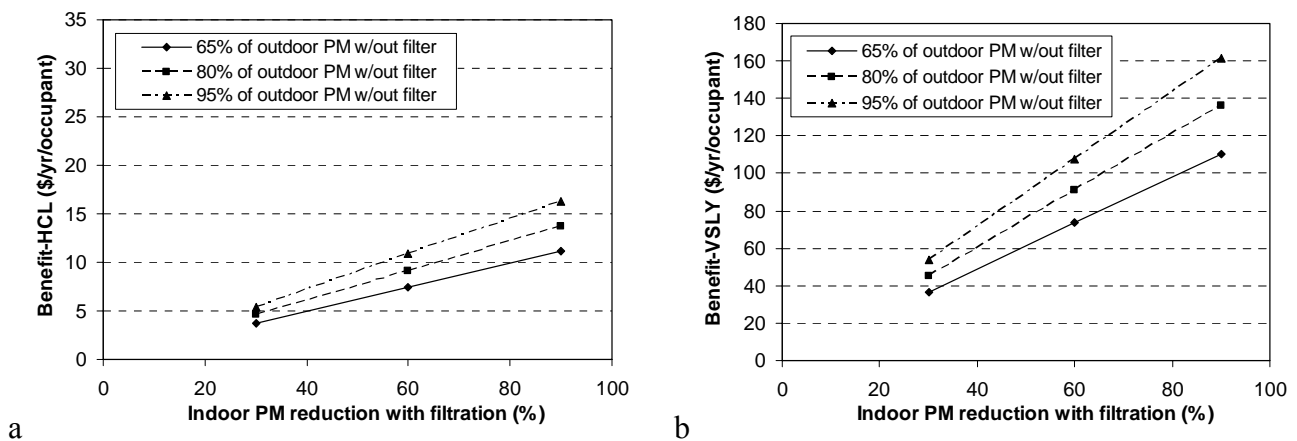

**Figure 1.** Economic benefits derived from decreased mortality rates as a function of average indoor PM10 concentration reduction with filtration. Benefits are depicted for scenarios that assume indoor PM10 concentration without filtration to be 65%, 80% or 95% of the outdoor PM level. The results determined using a) human capital losses and b) value of statistical life year are shown

### 3.2.1.2. Morbidity

The methodology of estimating the health benefits of filtration with regard to morbidity is similar to that for mortality. The population-weighted average baseline incidence rates for the 20-64 years age group were determined for respiratory hospital admissions and asthma ER visits based on the age-group-specified baseline incidence rates [37] and the US Census population data for the year 2000. The average baseline incidence rates for minor restricted activity days (MRAD) and work loss days (WLD) were taken from US EPA [40].

Given the purpose of the present analysis, we felt it was adequate to use approximate concentration–response functions determined in previous studies. We have chosen to use the estimates of C-R functions derived from a meta-analysis [36]; these are summarized in Table 3. We acknowledge that health effect relationships are region-specific and applying a C-R function from a single study or from several studies to all of the US or Europe introduces additional uncertainty.

**Table 3. Baseline rates, C-R functions and unit values of morbidity endpoints**

Health endpoint	% change per 10 $\mu\text{g}/\text{m}^3$ daily average PM10 *	Baseline rates (per 100 people per year)	Unit value per incident (\$)	Derivation of unit value estimates
Resp. hosp. admission	1.39	1.32	10750 **	COI
Asthma ER visit	3.11	0.57	302 **	COI
MRAD	4.92	780	59 **	WTP
Work loss days	7.74	237	184	Daily wage

\* from Cesar [36]

\*\* from US EPA [40]; Adjusted with 3% discount rate to 2005 dollars

The unit values for economic valuation of health endpoints (except work loss days) in 1990 dollars were taken from US EPA [40] and were adjusted by a 3% discount rate to 2005 dollar values (Table 3). Wherever possible, the report uses the “willingness to pay” approach to estimate the value of avoided morbidity. However, WTP estimates are not available for some health effects. In such cases the cost of treating or mitigating the effect is used as an alternative estimate. The cost of illness (COI) usually understates the true value as it only captures the estimates of medical costs and costs of lost work-time and it does not reflect the value of avoiding associated pain, suffering and lost leisure time. The value of loss workdays was based on the average daily salary of an office worker estimated as described earlier.

The results (Figure 2) were again obtained by linear scaling adjusting for the time period of the day and year that the occupants spend in the hypothetical office building. Results for respiratory hospital admissions and asthma ER visits are not displayed separately. Their maximum value for the changes in indoor PM concentrations examined in this analysis are below \$1.5 and \$0.05 per year per occupant, respectively, and thus they make a negligible contribution to the overall benefits of reduced morbidity.

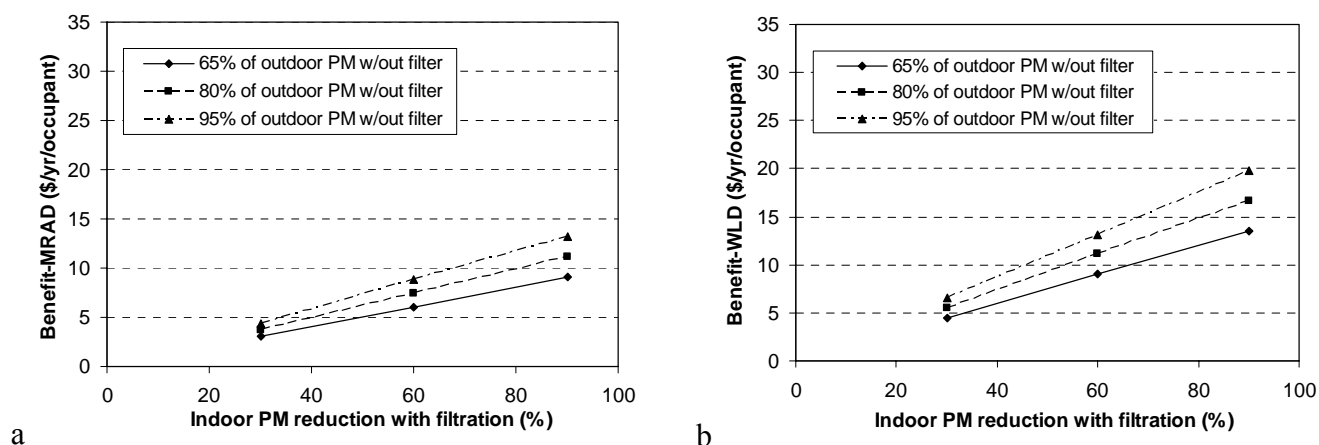

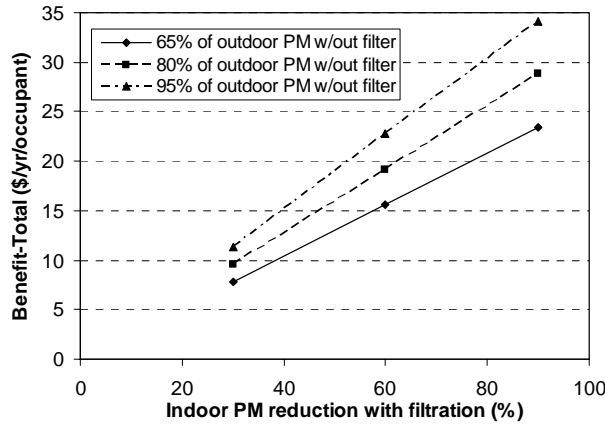

c

**Figure 2.** Economic benefits from decreased morbidity rates as a function of average indoor PM10 concentration reduction with filtration. Benefits are depicted for scenarios that assume indoor PM10 concentration without filtration to be 65%, 80% or 95% of the outdoor PM level. Results are shown for decreased rates of a) minor restricted activity days (MRAD), b) work loss days (WLD) and c) total morbidity

### 3.2.2. Building and HVAC duct cleaning

There is limited information on how cleaning affects people in indoor environments [42]. Cleaning products themselves can be a source of pollutants [43], and cleaning can contribute to indoor particulate pollution [44] from both the mechanical action of cleaning and the reaction of ozone with terpenes emitted by cleaning products [45]. Nonetheless, indoor air quality may be more adversely impacted by a lack of cleaning and inadequate cleaning programs [46]. Indeed, one study has reported that intensive cleaning in indoor environments reduces airborne dust levels and mucosal symptoms among occupants [47]. Cleaning has its greatest impact on coarse particles deposited on horizontal surfaces. Although it also reduces the surface concentration of fine particles deposited on vertical surfaces, these are less likely to be re-suspended by indoor activities [48].

Cleaning costs depend on the cleaning program. A routine cleaning program might consist of daily cleaning of important objects, weekly cleaning of less accessible areas and deep cleaning approximately 4 times a year (e.g. window cleaning). The annual cleaning cost in an average US building is about \$15.7 per m<sup>2</sup> per year [42] (adjusted by 3% discount rate to 2005 dollars). There is insufficient information to accurately estimate how changes in indoor airborne particle concentrations influence cleaning programs, the required degree of cleaning and the associated costs. Hence, we have conducted analysis for the impact of filtration on these economic costs using four different estimates of the initial cleaning costs (\$5, \$10, \$15 or \$20 per m<sup>2</sup> per year) when no filtration is in place. In making these estimates, we have tried to bracket the central tendency. Figure 3 displays the resulting economic benefits for each of the four scenarios.

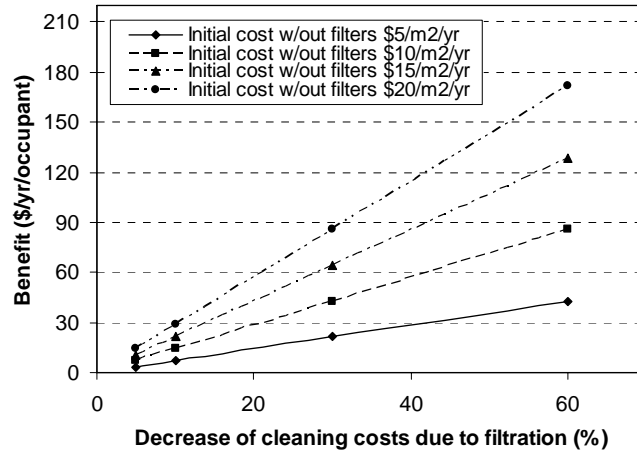

**Figure 3.** Economic benefits as a function of decrease of cleaning costs due to particle filtration. The correlation is shown for scenarios that assume \$5, \$10, \$15 or \$20 /m<sup>2</sup> per year cleaning cost when no filtration is used

Estimating the benefits with regard to HVAC unit cleaning, is not a simple task, since, in common practice, such cleaning is very irregular and often neglected. This is the case in spite of current standards in some countries. For example, based on a Finnish recommendation by FISIAQ (Finnish Society of Indoor Air Quality and Climate [49]), ventilation ducts in buildings should be cleaned when dust accumulation on duct surfaces exceeds 5 g/m<sup>2</sup>. Swedish guidelines recommend a 1 g/m<sup>2</sup> limit (see Pasanen [21]). Dust accumulation rates in ventilation ducts can be as high as a few g/m<sup>2</sup> per year without filtration; around 1 g/m<sup>2</sup> annually with a EU3 filter in place and around 0.3 g/m<sup>2</sup> annually with a EU7 filter in the system [21]. The required cleaning interval also depends on airflow, running time and outdoor environment. Camfil Farr's Life Cycle Cost software [29] assumes, for continuous HVAC operation, a cleaning interval of 5 years with a EU4 filter and 20 years with a EU7 filter in the ventilation system. The cost of ventilation duct cleaning can be estimated assuming an approximate duct area of 0.05 m<sup>2</sup> per m<sup>3</sup>/h airflow [29]. The cleaning cost per square meter of duct area varies from country to country. In Sweden the cost is estimated to be \$5 /m<sup>2</sup> [29]. The price of one-time cleaning in the present calculation, \$9,000, is derived from such estimates.. If we suppose that a system without filtration would be cleaned once in 5 years (rough cost of \$1800 /yr; disregarding discount rate for simplification) and with a EU7 filtration this period would increase to 15 years (\$600 /yr; disregarding discount rate), we roughly save up to \$1200 per year. That corresponds to a saving of \$1.2 per year per occupant, which contributes negligibly in comparison to the savings from less frequent building cleaning. Moreover, we understand that these results are highly dependant on the maintenance practice and facility management. Therefore we do not include more detailed calculation of this endpoint.

### 3.3. Estimate of productivity losses

Several recent studies have examined the adverse impact of indoor air pollution on performance of typical office work and the negative economic consequences [50-52]. Loaded ventilation filters are a potential source of sensory pollutants that can contribute to decreased office productivity. The magnitude of this impact is, however, difficult to estimate.

Wargocki [26] examined call-center operators' talk-time at two different outdoor air supply rates using supply air filters that were either new or had been in service for 6 months. At the high outdoor air supply rate (80% of total airflow, i.e. ~25L/s/person), replacing a used filter with a clean one improved operator performance as indicated by a 10% reduction in average talk-time. However, filter replacement had no significant effect on operator performance at the low outdoor air supply rate (8% of total airflow, i.e. ~2.5L/s/person). In another study by Wyon [25], replacing used supply air pre-filters in an office building with new ones increased the self-estimated productivity by 5.7%.

Alm [53] polled the percentage of occupants dissatisfied with air quality in a ventilated office during a 4-hour exposure. Upon entering the office, 47% of the subjects were dissatisfied with the room air quality with a used filter in the system, whereas only 16% were dissatisfied when a new filter was present. After an hour in the office, the subjects did not perceive a significant difference between the conditions. Based on this and other studies, he concluded that having a new filter in the ventilation unit instead of a used one had a positive effect on several perceptions, symptoms and self-estimated performance. However, at the resolution of his experiments, there was no significant effect on the measured performance of office work. Clausen [24] and Clausen [22] have reported and summarized other reports of negative influence of used filters on perceptions and health-related symptoms.

Previous studies [54,55] suggest that productivity increases between 1 and 1.5 % when the percentage dissatisfied with the air quality is decreased by 10%. However, it is not obvious that the results of the studies summarized above translate in a straightforward fashion to average office work. Based on various studies and assumptions, Fisk and Rosenfeld [17] estimated that the productivity decrease caused by typical SBS symptoms can be between 1 and 4%.

An additional factor to consider is the period of a filter's service-life during which it noticeably emits pollutants. This may differ with location, season, HVAC operation and filter type. Pasanen [20] tested the increase of perceived odor emissions with loading of ventilation filters by sensory evaluation of air quality upstream and downstream of various filters in a small-scale air handling unit. The authors concluded that during the first three months of intermittent operation of the filters in actual buildings the odor emissions increased to a level that every third person would consider unacceptable for indoor air quality. In the present analysis we have examined three different scenarios: decreased occupant productivity attributable to pollutants from a used filter occurs 3, 6 or 8 months after its installation (i.e., during 33, 50 or 75% of its service-life for a filter that is replaced yearly).

Given the rather large range of possible effects of emissions from used filters on occupant productivity (see above), we conducted a sensitivity analysis for the impact of productivity loss on the associated monetary loss (*monetary loss = %productivity loss/100 x \$46,000 annual compensation x % of occupants' work period that the filters pollute/100*). It has not been determined whether the initial negative impact of used filters on productivity changes as the filter further loads. Therefore we consider the chosen productivity loss to be an average value over the entire period during which the filter pollutes. The results are shown in Figure 4 for each of the three scenarios noted in the previous paragraph.



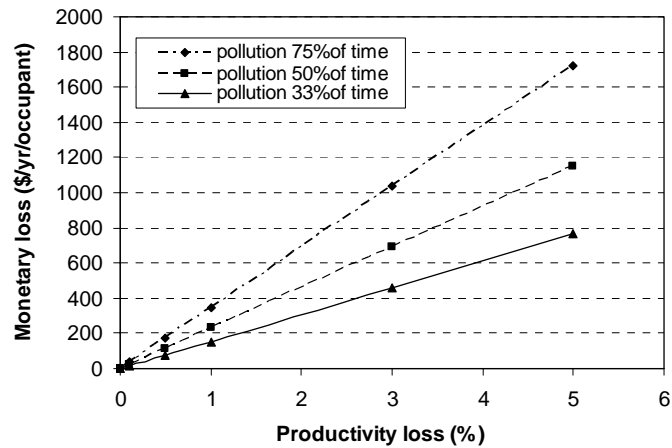

**Figure 4.** Monetary loss as a function of productivity loss due to pollutants from used ventilation filters. The correlation is depicted for three different scenarios: decreased occupant productivity occurs over 33, 50 or 75% of the filter’s service-life

The results indicate that even a small adverse effect of used filters on the occupants’ productivity results in meaningful economic losses. Such losses have the potential to be one to two orders of magnitude higher than the annual running costs of filtration and may substantially exceed its benefits. This is an area that warrants further investigation.

## 4. Discussion

### 4.1. Sample calculation

The results presented in the previous paragraphs must be interpreted cautiously. The input data for a number of parameters depend on factors such as building design, climatic zone and specific maintenance programs. We have therefore made lower, central and upper estimates of the benefits and costs associated with particle filtration. These have been calculated using lower, central and upper values, as determined from the literature and our judgment, for key input variables (see Table 4).

**Table 4.** Input values used for the lower, central and upper estimates of endpoints associated with the use of particle filtration

Estimate	Input variables					
	Mortality and morbidity		Building cleaning		Productivity	
	Indoor PM level w/out filters (%of outdoor PM)	Indoor PM reduction with filters (%)	Cleaning cost decrease due to filtration (%)	Initial cost w/out filtration (\$/m <sup>2</sup> /yr)	Productivity loss (%)	Polluting period of filter service time (%)
Lower	65	30	5	5	0	-
Central	80	60	30	10	0.5	50
Upper	95	80	40	15	1.0	75

Moreover, different stakeholders perceive costs and benefits of filtration differently. For instance, a building owner who sublets a building to an employer is not directly impacted by changes in morbidity and mortality rates within the building; the employer renting the building is impacted by changes in morbidity and mortality rates in one way; the employee is impacted by changes in morbidity and mortality rates in another way. Hence, in the overall analysis presented in Figure 5, we consider four different perspectives:

- Perspective of owner: subletting the building; pays for building maintenance, but not for energy use
- Perspective of employer: renting the building; does not pay for building maintenance, but does pay for energy use
- Perspective of employer that owns the building; responsible for building maintenance and energy use
- Perspective of Society: total costs and benefits are relevant

This approach has its own weaknesses. For example, an employer encounters economic losses as a consequence of the premature death of an employee (lost productivity resulting from disruption, loss of knowledge and training of a replacement); however, such losses are not properly captured via the “human capital” or “willingness to pay” approaches. Given the inadequacy of these metrics, benefits from decreased mortality rates were not included in the estimates presented in Figures 5b and 5c. Similarly, since medical costs are typically not directly borne by the employer, benefits from decreased morbidity rates (other than work loss days) were not included in the estimates presented in Figures 5b and 5c. (However, fractional investment of the employer in the employee’s health insurance would impact this parameter.) The salient point is that Figure 5 does not capture all of the benefits that accrue to the employer when particle filtration is used.

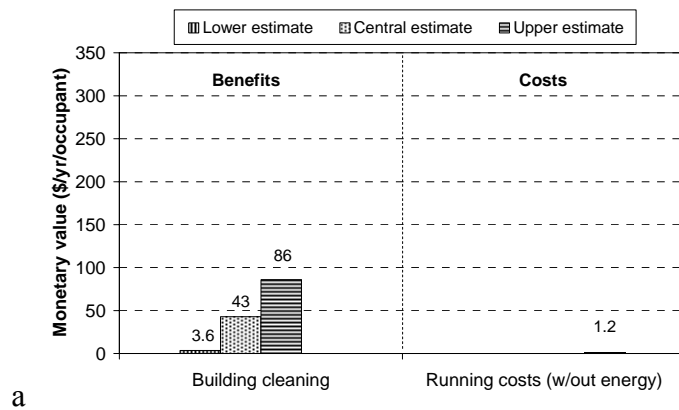

a

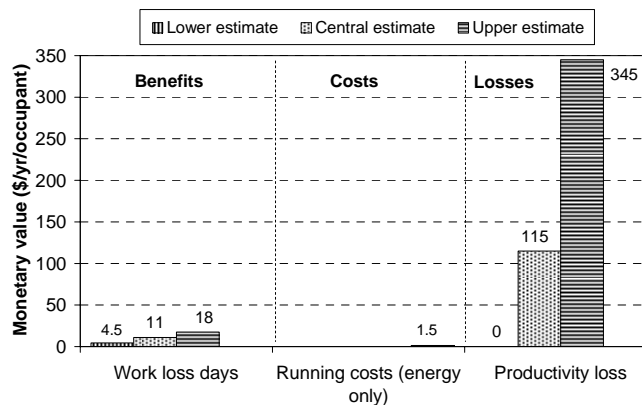

b

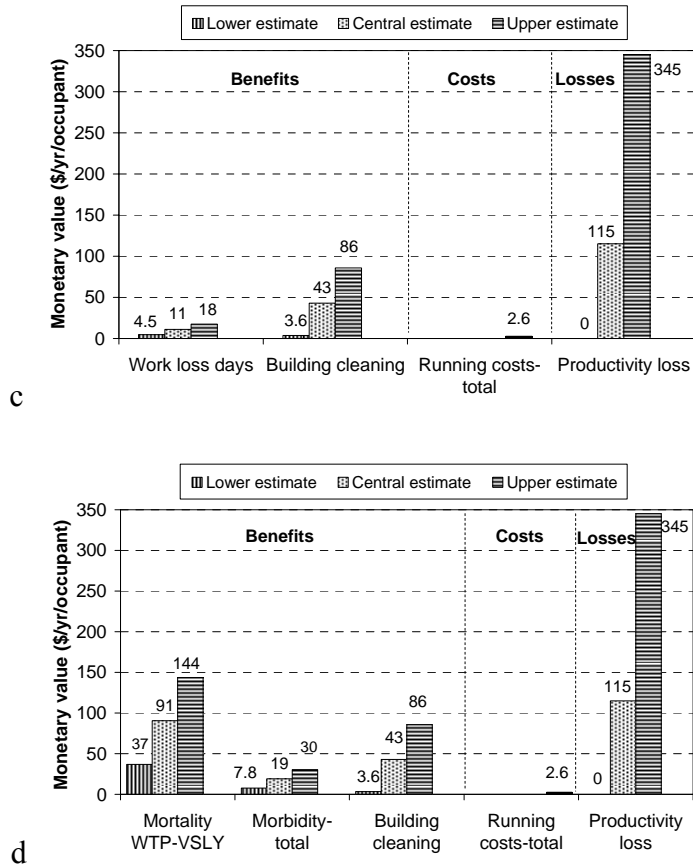

**Figure 5.** Lower, central and upper estimates of the aggregated benefits and costs of particle filtration from four perspectives: a) building owner, b) employer, c) employer/ building owner and d) society (see text for details)

Although the evaluations presented in Figure 5 are only rough estimates, they indicate that, regardless of perspective, removal of particulate air pollution from the supply air is beneficial if the negative aspects of loaded particle filters can be avoided. However, if loaded filters pollute the air that passes through them and cause even a small productivity loss, potential economic benefits can easily be overwhelmed by decreased worker efficiency. It is anticipated that more frequent filter changes would partially mitigate this effect. This implies that filter changes should be based on odors emanating from the filter as well as pressure drop across the filter. Indeed, Fitzner [56] states that pressure drop is only a measure of useful filter life when outdoor air pollution is quite large and the “change-out” pressure drop is reached within one year.

Additional benefits, not included in the present analysis, include reduced soiling of heat exchangers and energy recovery units. Soiling of HVAC systems not only reduces the efficiency of heat exchangers and energy recovery units, but can also be a source of sensory offending emissions (similar to those emanating from loaded filters). We have not included these endpoints in the model since the necessary input data are not available. However, our rough estimates of the benefits obtained from reduced soiling of HVAC components (not presented here) indicate that the value of these benefits are somewhere between negligible and the same order of magnitude as the annual running costs of filtration.

It should be remembered that the reference condition for the current comparison was an identical HVAC system with no filter in place. That is, the present study does not address the costs and benefits of *improved* filtration. However, it does provide a sense of the endpoints that would be most influenced by upgrading existing particle filtration.

#### *4.2. Influence of recirculation*

The present analysis is for a one-pass ventilation system. However, in many parts of the world (e.g., Europe outside of Scandinavia, the United States, Singapore) as much as 80% to 90% of the supply air is recirculated. In a scenario where 80% of the total airflow is recirculated air and the amount of outside air is 10 L/s/occupant, the total airflow through the ventilation unit would be 50 m<sup>3</sup>/s (i.e., five times larger than in a system with no recirculation). Hence, for an identical face velocity, the size of the filter bank and consequently the energy, filter replacement and disposal costs would increase. However, these increases would be somewhat less than a factor of five since the pressure drop would be anticipated to increase at a slower rate despite the added filtration of particles of indoor origin.

We may assume that the relatively large benefits resulting from the filtration of outdoor particles would be similar with and without the use of recirculating air. Moreover, since the particle filters are commonly placed downstream of the mixing box in systems with recirculation, the concentration of indoor generated particles would be less in such a system. This is expected to be beneficial in terms of both health and frequency of surface cleaning. We should be mindful of the fact that the filter cake accrued on filters in a recirculating system differs from that in a one-pass system, and the temperature of the air passing through the filters is likely to be different in the two systems. These differences could influence pollutants emanating from a used filter and potential effects on occupant productivity.

Taken together, this cursory examination suggests that the benefits still outweigh the running costs in a system that recirculates a large fraction of the supply air. However, additional studies and detailed analyses are necessary to adequately address the costs and benefits associated with filtration in a building that uses such a system.

### **5. Conclusions and implications**

The present study indicates that the overall benefits of using particle air filtration are several times larger than the associated running costs. The magnitude of the net benefits varies with the perspective and valuation approach. For society as a whole, a major portion of the benefits derives from reduced occupant mortality and morbidity due to decreased particulate air pollution. Savings on building cleaning programs are substantial for building owners as well as society. On the other hand, significant economic benefits obtained from lower indoor particle concentrations may easily be overwhelmed by even a small decrease in occupant productivity as a consequence of sensory offending pollutants emanating from used particle filters. Alternatives to current filtration practices may be able to avoid this pitfall. Investigating such alternatives using economic analyses analogous to those used in this work, supported by experimental studies, is warranted. Evaluating more frequent filter replacement is a simple starting point. Best practice should move towards the development and use of efficient, low-polluting filtration systems that are easy to maintain, have low life cycle costs and minimal environmental impact.

## Acknowledgements

This work has been supported by the Danish Technical Research Council (STVF) as part of the research program of the International Centre for Indoor Environment and Energy established at the Danish Technical University for the period 1998-2007. The authors would like to thank Professors Kirk Smith and William W. Nazaroff, both from University of California, Berkeley, for providing helpful literature and valuable comments. We thank Niels-Erik Kongste from Camfil Farr Denmark for providing us with the Life Cycle Cost software.

## References

- [1] Dockery DW, Pope CA III, Xu X, Spengler JD, Ware JH, Fay ME, Ferris BG, Speizer FE. An association between air pollution and mortality in six US cities. *The New England Journal of Medicine* 1993; 329 (24): 1753-59.
- [2] Pope CA III, Thun MJ, Namboodiri MM, Dockery DW, Evans J, Speizer FE, Heath C. Particulate air pollution as a predictor of mortality in a prospective study of US adults. *American Journal of Respiratory and Critical Care Medicine* 1995; 151: 669-674.
- [3] Pope CA III, Burnett RT, Thun MJ, Calle EE, Krewski D, Ito K, Thurston GD. Lung cancer, cardiopulmonary mortality and long-term exposure to fine particulate air pollution. *Journal of American Medical Association* 2002; 287 (9): 1132-1141.
- [4] Dominici F, Peng RD, Bell ML, Pham L, McDermott A, Zeger SL, Samet JM. Fine particulate air pollution and hospital admission for cardiovascular and respiratory diseases. *Journal of American Medical Association* 2006; 295 (10): 1127-1134.
- [5] Sandström T, Nowak D, Van Bree L. Health effects of coarse particles in ambient air: messages for research and decision-making. *European Respiratory Journal* 2005; 26: 187-188.
- [6] US EPA NAAQS. United States Environmental Protection Agency, National Ambient Air Quality Standards for Particulate Matter; 1997. (<http://www.epa.gov/ttnamti1/pmcf.html>. In 40 CFR Part 50, AD-FRL-5725-2).
- [7] WHO. WHO air quality guidelines global update 2005. Report on a working group meeting. World Health Organization, Bonn, Germany; 18-20 October 2005.
- [8] Clayton CA, Perritt RL, Pellizzari ED, Thomas KW, Whitmore RW, Wallace LA, Özkaynak H, Spengler JD. Particle total exposure assessment methodology (PTEAM) study: distributions of aerosol and elemental concentrations in personal, indoor and outdoor air samples in a southern California community. *Journal of Exposure Analysis and Environmental Epidemiology* 1993; 3: 227-250.
- [9] Wallace L. Indoor particles: a review. *Journal of the Air & Waste Management Association* 1996; 46: 98-126.
- [10] Riley WJ, McKone TE, Lai AK, Nazaroff WW. Indoor Particulate Matter of Outdoor Origin: Importance of Size-Dependent Removal Mechanisms. *Environmental Science and Technology* 2002; Vol. 36: 200-207.
- [11] Weschler CJ, Shields H, Shah B. Understanding and reducing the indoor concentration of submicron particles at a commercial building in Southern California. *Journal of the Air & Waste Management Association* 1996; 46: 291-299.
- [12] Hänninen OO, Palonen J, Tuomisto JT, Yli-Tuomi T, Seppänen O, Jantunen MJ. Reduction potential of urban PM<sub>2.5</sub> mortality risk using modern ventilation systems in buildings. *Indoor Air* 2005; 15: 246-256.

- [13] Mendell MJ, Fisk WJ, Petersen M, Dong MX, Hines CJ, Faulkner D, Deddens JA, Ruder AM, Sullivan D, Boeniger MF. Enhanced particle filtration in non-problem office environment: summary finding from a double-blind crossover intervention study. In: Proceedings of Indoor Air 1999. Edinburgh; 1999, Vol. 4: 974-975.
- [14] Fisk WJ, Faulkner D, Palonen J, Seppänen O. Performance and costs of particle air filtration technologies. *Indoor Air* 2002; 12: 223-234.
- [15] Jamriska M, Morawska L, Ensor DS. Control strategies for sub-micrometer particles indoors: model study of air filtration and ventilation. *Indoor Air* 2003; 13: 96-105.
- [16] EN13779. Ventilation for non-residential buildings. Performance requirements for ventilation and room-conditioning systems. European standard; 2004.
- [17] Fisk WJ, Rosenfeld AH. Estimates of improved productivity and health from better indoor environments. *Indoor Air* 1997; 7: 158-172.
- [18] Weschler CJ. Predictions of benefits and costs derived from improving indoor air quality in telephone switching companies. *Indoor Air* 1991; 1: 65-78.
- [19] Camfil Farr. Keeping the cost of clean air down. *Airmail. News magazine from Camfil Farr*; 2003, 2: 2-4.
- [20] Pasanen P, Teijonsalo J, Seppänen O, Ruuskanen J, Kalliokoski P. Increase in perceived odor emissions with loading of ventilation filters. *Indoor Air* 1994; 4: 106-113.
- [21] Pasanen P. Emissions from filters and hygiene of air ducts in the ventilation systems of office buildings. Doctoral dissertation, Kuopio University Publications C. Natural and Environmental Sciences 80; 1998, p. 1-77.
- [22] Clausen G. Ventilation filters and indoor air quality: a review of research from the International Centre for Indoor Environment and Energy. *Indoor Air* 2004; 14 (S7): 202-207.
- [23] Bekö G, Halás O, Clausen G, Weschler CJ. Initial studies of oxidation processes on filter surfaces and their impact on perceived air quality. *Indoor Air* 2006; 16: 56-64.
- [24] Clausen G, Alm O, Fanger PO. The impact of air pollution from used ventilation filters on human comfort and health. In: Proceedings of the 9<sup>th</sup> International Conference on Indoor Air Quality and Climate, *Indoor Air 2002*. Monterey, USA; 2002, Vol. 1: 338-343.
- [25] Wyon DP, Tham KW, Croxford B, Young A, Oreszczyn T. The effects on health and self-estimated productivity of two experimental interventions which reduced airborne dust levels in office premises. In: Proceedings of Healthy Buildings 2000. Espoo, Finland; 2000, Vol. 1: 641-646.
- [26] Wargocki P, Wyon DP, Fanger PO. The performance and subjective responses of call-centre operators with new and used supply air filters at two outdoor air supply rates. *Indoor Air* 2004; 14 (S8): 7-16.
- [27] CEN CR1752. Ventilation for buildings – Design criteria for the indoor environment. European Committee for Standardization; 1998.
- [28] US Department of Labor. Bureau of Labor Statistics. National compensation survey: Occupational wages in 2005; 2005. (<http://www.bls.gov/ncs/home.htm>).
- [29] Camfil Farr. Life Cycle Cost software 1.47EU. Camfil Farr; 2001-2002.
- [30] EUROVENT. Recommendation concerning calculation of life cycle costs for air filters. European committee of air handling, air conditioning and refrigeration equipment manufacturers; January, 1999.
- [31] Bánhidi L, Kajtár L. Komfortelmélet. Chapter 18: A levegő szűrése szálás szűrőkben. Műegyetemi kiadó, Budapest; 2000, p. 321-352 (in Hungarian).
- [32] Hangström K, Holmber R, Lehtimäki M, Riljo J, Siitonen E. Hinkkassuodatuksen perusteet ja optimaalinen valinta. INVENT/Suodatin-projekti, Vaihe 1, Raportti 48, MET; 1996, 1-54. (in Finnish).

- [33] WHO. Reducing risks, promoting healthy life. The world health report 2002. World Health Organisation; 2002.
- [34] Cohen AJ, Anderson HR, Ostro B, Pandey KD, Krzyzanowski M, Künzli N, Gutschmidt K, Pope CA III, Romieu I, Samet JM, Smith KR. Urban air pollution. In: Ezzati M, Lopez AD, Rodgers A, Murray CJL. editors. Comparative quantification of health risks. Global and Regional Burden of Disease Attributable to Selected Major Risk Factors. WHO; 2004, Vol. 1: 1354-1433.  
(<http://www.who.int/publications/cra/chapters/volume2/1353-1434.pdf>).
- [35] Wallace L. Correlations of Personal Exposure to Particles with Outdoor Air Measurements: A Review of Recent Studies. *Aerosol Science & Technology* 2000; Vol.32 (1): 15-25.
- [36] Cesar H, Borja-Aburto VH, Cicero-Ferandez P, et al. Improving air quality in metropolitan Mexico City. An economic valuation. Policy research working paper 2785, The World Bank; 2002.  
([http://www-wds.worldbank.org/external/default/WDSContentServer/WDSP/IB/2002/03/08/000094946\\_02022604025131/Rendered/PDF/multi0page.pdf](http://www-wds.worldbank.org/external/default/WDSContentServer/WDSP/IB/2002/03/08/000094946_02022604025131/Rendered/PDF/multi0page.pdf)).
- [37] Hubbell BJ, Hallberg A, McCubbin DR, Post E. Health-related benefits of attaining the 8-hr ozone standard. *Environmental Health Perspectives* 2005; Vol. 113 (1): 73-82.
- [38] CDC. CDC WONDER (1996-1998). Atlanta, GA: Center for Disease Control and Prevention; 2005. (<http://wonder.cdc.gov>).
- [39] US Census Bureau. Accessed via CDC WONDER on-line database, Center for Disease Control and Prevention; 2005. (<http://wonder.cdc.gov>).
- [40] US EPA. The benefits and costs of the clean air act. Report to Congress. Environmental Protection Agency; 1999.
- [41] Cifuentes L, Borja-Aburto VH, Gouveia N, Thurston G, Davis DL. Assessing the Health Benefits of Urban Air Pollution Reductions Associated with Climate Change Mitigation (2000–2020): Santiago, São Paulo, México City, and New York City. *Environmental Health Perspectives* 2001; 109 (S3): 419-425.
- [42] Kildesø J, Schneider T. Prevention with cleaning. In: Spangler JD, McCarthy JF, Samet JM. editors. *Indoor air quality handbook*. McGraw-Hill, New York; 2001, 64.1-64.18.
- [43] Nazaroff WW, Weschler CJ. Cleaning products and air fresheners: exposure to primary and secondary air pollutants. *Atmospheric Environment* 2004; 38: 2841-2865.
- [44] Kildesø J, Tornvig L, Skov P, Schneider T. An intervention study of the effect of improved cleaning methods on the concentration and composition of dust. *Indoor Air* 1998; 8: 12-22.
- [45] Weschler CJ, Shields H. Indoor ozone/terpene reactions as a source of indoor particles. *Atmospheric Environment* 1999; 33: 2301-2312.
- [46] Franke DL, Cole EC, Leese KE, Foarde KK, Berry MA. Cleaning for improved indoor air quality: an initial assessment of effectiveness. *Indoor Air* 1997; 7: 41-54.
- [47] Skulberg KR, Skyberg K, Kruse K, Eduard W, Djupesland P, Levy F, Kjuus H. The effect of cleaning on dust and the health of office workers: An intervention study. *Epidemiology* 2004; 15 (1): 71-78.
- [48] Thatcher T, Layton D. Deposition, resuspension, and penetration of particles within a residence. *Atmospheric Environment* 1995; 29: 1487–1497.
- [49] FISIAQ. Classification of indoor climate, construction and finishing materials. Finnish society of indoor air quality and climate, Espoo, Finland; 1995.
- [50] Wargocki P, Wyon DP, Baik YK, Clausen G, Fanger PO. Perceived air quality, Sick Building Syndrome (SBS) symptoms and productivity in an office with two different pollution loads. *Indoor Air* 1999; 9: 165–179.

- [51] Wargocki P, Wyon DP, Sundell J, Clausen G, Fanger PO. The effects of outdoor air supply rate in an office on perceived air quality, Sick Building Syndrome (SBS) symptoms and productivity. *Indoor Air* 2000; 10: 222–236.
- [52] Djukanovic R, Wargocki P, Fanger PO. Cost-benefit analysis of improved air quality in an office building. In: *Proceedings of Indoor Air 2002*. Monterrey, USA; 2002, Vol. 1: 808-813.
- [53] Alm O. Ventilation filters and their impact on human comfort, health and productivity. Doctoral Dissertation (PhD thesis MEK-I-Ph.D. 01.02). International Centre for Indoor Environment and Energy, Technical University of Denmark, Lyngby; 2001.
- [54] Wargocki P, Wyon DP, Fanger PO. Productivity is affected by the air quality in offices. In: *Proceedings of Healthy Buildings 2000*. Espoo, Finland; 2000, Vol. 1: 635-640.
- [55] Wargocki P, Wyon DP, Fanger PO. Pollution source control and ventilation improve health, comfort and productivity. In: *Proceedings of the Third International Conference on Cold Climate Heating, Ventilating and Air Conditioning - Cold Climate HVAC 2000*. Sapporo, Japan; 2000, 445-450.
- [56] Fitzner K. Control of pollutants in air handling systems. In: *Proceedings of Healthy Buildings 2000*. Espoo, Finland; 2000, Vol. 2: 21-33.



#### **4.4 Sensory pollution from bag filters, carbon filters and combinations**

**Paper to be published in:**

Indoor Air

**Publisher:**

Blackwell Publishing Ltd., Blackwell Munksgaard

**Paper submitted on:**

30 May, 2007

## **Sensory pollution from bag filters, carbon filters and combinations**

Gabriel Bekö<sup>1,2</sup>, Geo Clausen<sup>2</sup>, Charles J. Weschler<sup>2,3</sup>

<sup>1</sup>Faculty of Civil Engineering, Department of Building Services, Slovak University of Technology, Radlinského 11, 813 68 Bratislava, Slovakia

<sup>2</sup>International Centre for Indoor Environment and Energy, Department of Mechanical Engineering, Technical University of Denmark, Nils Koppels Allé, Building 402, DK-2800 Lyngby, Denmark

<sup>3</sup>Environmental and Occupational Health Sciences Institute, UMDNJ-Robert Wood Johnson Medical School & Rutgers University, Piscataway, NJ 08854 USA

Corresponding author:

Gabriel Bekö  
International Centre for Indoor Environment and Energy  
Technical University of Denmark  
Nils Koppels Allé, Building 402  
DK-2800 Lyngby, Denmark  
Phone: (+45) 45 25 40 18, fax: (+45) 45 93 21 66  
E-mail: gb@mek.dtu.dk

## **Abstract**

Used ventilation filters are a major source of sensory pollutants in air handling systems. The objective of the present study was to evaluate the net effect that different combinations of filters had on perceived air quality after five months of continuous use. A panel of 32 subjects assessed different sets of used filters and identical sets consisting of new filters. Additionally, filter weights and pressure drops were measured at the beginning and end of the operation period. The filter sets included single EU5 and EU7 fiberglass filters, an EU7 filter protected from coarse particles by a pre-filter that was exchanged monthly, an EU7 filter protected by an upstream activated carbon filter, and EU7 filters with an activated carbon filter either downstream or both upstream and downstream. In addition, two types of stand-alone combination filters were evaluated: a bag-type fiberglass filter that contained activated carbon and a synthetic fiber cartridge filter that contained activated carbon. Air that had passed through used filters was most acceptable for those sets in which an activated carbon filter was used downstream of the particle filter. Importantly, comparable air quality was achieved with the stand-alone bag filter that contained activated carbon. Furthermore, its pressure drop changed very little during the five months of service, and it had the added benefit of removing a large fraction of ozone from the airstream. If similar results are obtained over a wider variety of soiling conditions, such filters may be a viable solution to a long recognized problem.

## **Key words**

Ventilation filters, Perceived air quality, Activated carbon filter, Sensory pollution

## **Practical implications**

The present study was designed to address the emission of sensory offending pollutants from loaded ventilation filters. The goal was to find a low-polluting solution from commercially available products. The results indicate that the use of activated carbon filters downstream of fiberglass bag filters can reduce the degradation of air quality that occurs with increasing particle loading. A more practical solution, yet comparably effective, is a stand-alone particle filter that incorporates activated carbon. In either case, further testing under a variety of conditions is recommended before making design decisions regarding the type of filters best suited to efficient building operation.

## **Introduction**

The benefits of using supply air filters in ventilation and air-conditioning units are well known (Fisk et al., 2002). However, used filters can emit sensory pollutants, which degrade the perceived quality of the ventilation air (Pejtersen et al., 1989, 1996; Pasanen et al., 1994; 1998; Alm, 2001; Clausen, 2004). At the same time they can contribute to sick building syndrome (SBS) symptoms (Clausen et al. 2002) and negatively impact occupant performance (Wyon et al., 2000; Wargocki et al., 2004a).

The surface area of particles captured on a filter over a period of 6 months can easily approach 300 m<sup>2</sup> for a filter with an area of 0.36 m<sup>2</sup> (60 x 60 cm) (Weschler, 2003). Various organic compounds such as those emitted by combustion processes or vegetation are

associated with the captured particles. Some of these can desorb into the airstream while others can react with ozone contained in the air passing through the filters. The latter process results in the removal of ozone from the ventilation air by used ventilation filters (Bekö et al., 2006, 2007; Hyttinen et al., 2003; Hyttinen et al., 2006; Zhao et al., 2007). However, the products of ozone initiated oxidation reactions and other chemical transformations may desorb to the airstream and contribute to the degradation of perceived air quality (Weschler, 2004). Desorption processes may be amplified when HVAC fans are first turned on after a period when the ventilation system has not been in operation (Mølhav and Thorsen, 1991). Mysen et al. (2003) demonstrated that, in comparison with continuous operation, turning off or reducing the airflow through a filter outside working hours increased the sensory pollution emitted from a used bag filter immediately after the ventilation system was turned back on. Similarly, Bekö et al. (2006) found that when a filter is in continuous service, the formation and subsequent off-gassing of oxidation products is much smaller than when a filter initially returns to service after a break in operation.

The extent to which the described chemical processes occur on used filter surfaces may depend on the amount of particulate mass captured on the filter surface (Hyttinen et al., 2006), location, season, filter type and position of the filter in the ventilation unit. The studies of Hyttinen et al. (2001), Hyttinen et al. (2007) and Pasanen (1998) indicate that loaded pre-filters have higher odor emission rates than loaded final filters. Pasanen (1994) concluded that the use of pre-filters decreased the odorous emissions coming from final filters. The authors recommended frequent changes of pre-filters, designed to remove primarily coarse particles, in order to minimize odorous emissions from ventilation units.

Activated carbon (AC) filters can effectively remove ozone and selected organic pollutants from airstreams. Shair (1981) investigated the use of activated charcoal filters for the removal of ozone in a demonstration project and concluded that this was an economically viable approach to significantly reduce the outdoor-to-indoor transport of ozone. Weschler et al. (1993, 1994) and Shields et al. (1999) examined the ozone removal of several activated carbon filters over several years of operation. The authors found that a carbon filter downstream of both a pre-filter and an 85% filter (equivalent to an EU7) still removed 90% of the ozone in air passing through it after 5 years of continuous operation. Another carbon filter similarly protected by particle filters removed 70% of the ozone in the airstream after 7 years of continuous operation. A carbon filter protected by only a pre-filter removed 60% of the ozone after 8 years of continuous operation. In a recent laboratory study of a scaled down activated carbon filter (Zhao, 2006), the filter removed close to 100% of the ozone in a test airstream over a period of five months. However, this evaluation was conducted at a decreased airflow, with a face velocity of  $0.36 \text{ cm s}^{-1}$ .

Mysen et al. (2006) compared the perceived air quality downstream of a regular F7/EU7 bag filter with that from a bag filter that incorporated activated carbon. Both filters were in service for three months under identical conditions. In subsequent evaluations, the air quality was perceived to be significantly better downstream of the used carbon-containing bag filter than downstream of the standard bag filter.

Clausen (2004) has observed: “The most obvious solution (to polluting filters) would be to completely remove the particles from the air stream. ... If particles are collected by a filter media it is important to somehow remove the collected particles on the filter surface ...” Until such advances occur, emissions from used filters must be minimized using available technology. The objective of the present study was to find one or more combinations of

commercially available HVAC filters that have low emissions of sensory offending pollutants after extensive use under realistic conditions. Sensory evaluations have been performed for eight filters or filter combinations; the combinations included either pre-filters or activated carbon filters. Each filter or filter set was soiled under identical service conditions. Achieving lower emissions of sensory offending pollutants from used filters has the potential to improve air quality, reduce SBS symptoms and increase performance with only a modest increase in operating costs.

## Methods

Eight test plenums were assembled to evaluate various filter types or filter combinations. The units were situated outdoors in a suburb of Copenhagen, Denmark, at a distance roughly 150 meters from a moderately active highway. Each test plenum consisted of one or more 0.3 x 0.6m filter boxes, reduction pieces, connecting ductwork, circular duct fans and a damper to regulate the flow of air through the filters (Figure 1). The duct fans were sized to overcome the predicted total pressure drop of the system at the end of the experiments. The inlets of the units were protected from large objects, leaves, tree litter and precipitation. The airflow through the systems was adjusted to  $\sim 1300 \text{ m}^3/\text{h}$  to achieve a standard 2 m/s face velocity through the filters. This corresponds to 75% or 85% of the maximum recommended airflow through bag filters or cartridge filters, respectively. As part of the adjustment of the required airflow in each setup, the pressure drop over an integrated orifice was measured. The eight orifices were initially cross-calibrated, in order to achieve identical airflow in each unit. The units were continuously operated from 18 August 2006 to 24 January 2007 -- a little over 5 months.

The eight filter sets placed in the respective plenums were: i) Single EU7 fiberglass filter, intended to serve as the reference condition; ii) EU7 fiberglass filter, protected by an EU4 pre-filter that was exchanged monthly. A fraction of the sensory offending pollutants was removed by the pre-filters; iii) EU7 fiberglass filter with an activated carbon (AC) filter upstream, intended to limit ozone initiated reactions on the surface of the EU7 filter; iv) EU7 fiberglass filter with an AC filter downstream, intended to remove a fraction of the sensory offending pollutants desorbing from the EU7 filter; v) EU7 fiberglass filter with AC filters both upstream and downstream, combining the intended benefits of AC filters in the previous two sets; vi) stand-alone EU7 bag filter with carbon-containing fiberglass media; vii) stand-alone EU7 synthetic fiber cartridge filter that incorporates AC and viii) Single EU5 fiberglass filter, intended to represent a commonly used configuration. The activated carbon in the two combination filters (sets vi and vii) is anticipated to capture sensory offending pollutants and possibly reduce surface chemistry. Further descriptions of the filters and their combinations can be found in Table 1.

Each filter was weighed before and after the 5-month soiling period to determine the mass change during the period that the filters were in service. The measurements, made in duplicate and subsequently averaged, took place in a climate chamber at 21°C and 65% RH. All filters equilibrated at these conditions for approximately 20 hours prior to weighing, both before and after the 5-month service time.

During the soiling period, the airflow through the systems was checked on a monthly basis and, when necessary, readjusted to the original value ( $1300 \text{ m}^3/\text{h}$ ). The pressure drop across each filter also was measured monthly using a Testo 511 temperature-compensated pressure

meter. The accuracy of the instrument is  $\pm 3$  Pa for values between 0 and 100 Pa and  $\pm 1.5\%$  of measured value up to 1000 Pa. Fifteen values, each recorded over a one-second interval, were averaged for each filter. Pressure drops were measured on days without precipitation to avoid complications from moisture laden air. The outdoor air temperature and relative humidity varied between 7-19 °C and 70-90% RH for the days on which the monthly pressure drops were measured. On the day of the first pressure drop measurements the conditions were 19°C, 70% RH and a wind speed of 26 km/h. On the day of the last pressure drop measurements the conditions were 7°C, 80% RH and a wind speed of 30km/h (Weather Underground, 2007).

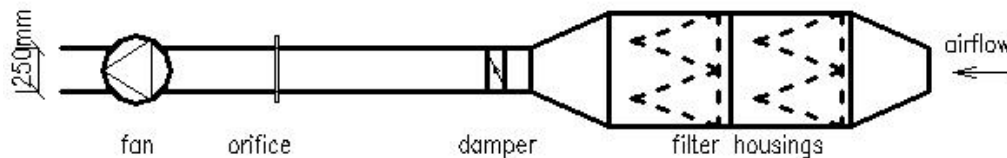

**Figure 1.** Test plenum configuration used for soiling and testing several filter types, either alone or in combinations. The number of filter boxes within each unit was based on the number of filters in a given filter set

After 5 months of operation, the filters were taken out of the test plenums, which continued to run at airflows of 1300m<sup>3</sup>/h for an additional day to purge the units of residuals from the used filters. During this period, the filters were stored outdoors in sealed plastic bags. Three of the test plenums were then washed and moved into separate 55m<sup>3</sup> field laboratories, each ventilated with 110 L/s outdoor air (7 air changes per hour). To avoid contamination of the room air with air that had passed through used filters, the exhaust from each plenum was vented to the outside using flexible duct that passed through a window (Figure 2). Prior to sensory evaluations, the three units ran for two days without filters at the airflow of 1300 m<sup>3</sup>/h, in order to equilibrate with indoor conditions. All used and new filters were moved indoors and ventilated for 45 minutes with 130 m<sup>3</sup>/h of room air (one tenth of the nominal flow) two days prior to their sensory evaluations. The average temperature and relative humidity in the rooms during the period of pre-treatment were 20.5 °C and 30 %, respectively. The ozone concentration in the three field laboratories was between 15 ppb and 25 ppb.

On the day of the sensory assessments, each filter set was again ventilated for 45 minutes with 130 m<sup>3</sup>/h of room air prior to the sensory evaluations. The same airflow was used during the assessments. It corresponds to an air velocity of 0.2m/s through the filter and 0.7m/s at the point of sensory assessment. The average temperature and relative humidity in the test rooms during the assessments was 21 °C and 25 %, respectively, while the ozone concentration was 20 to 25 ppb on the first day and 5 to 15 ppb on the second day.

In total 16 filter sets were evaluated. Eight of them consisted of one or more used filters, all of them being identically soiled during the previous months (Table 1). The other eight sets matched the first ones, but consisted of new filters of the same types. The new filter sets were pre-conditioned in a manner that was identical to that employed for the used ones (i.e., they were ventilated twice for 45 minutes with 130 m<sup>3</sup>/h of room air). In addition, each of the three test plenums, without filters, was evaluated several times during the two assessment days. Hence, twenty-four conditions were evaluated in random order in three field labs. The evaluations were carried out during two consecutive days, using the same panel of subjects.

Randomization of conditions was limited by the number of filters in every experimental set and the number of filter housings available within the three test plenums.

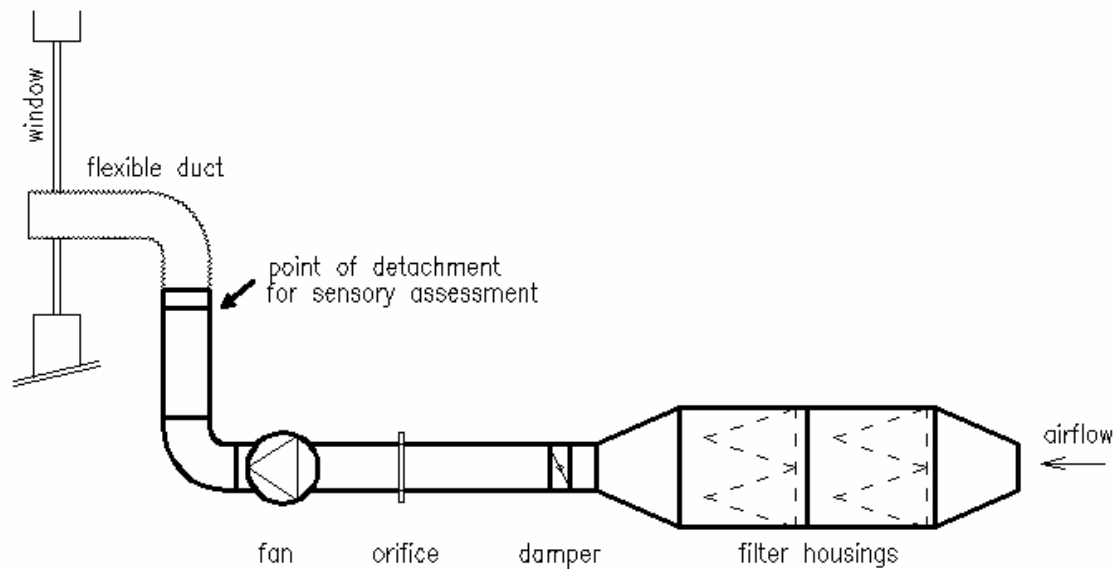

**Figure 2.** Scheme for one of the test plenums installed in the field labs during the sensory assessments. The three test plenums contained different number of filter boxes so that all filter sets could be evaluated

Thirty-two untrained human subjects between 20 and 27 years of age assessed the acceptability of air downstream of each set of filters. They used the continuous acceptability scale, which ranges from “Clearly unacceptable” (-1) to “Clearly acceptable” (+1). There was a break in the scale in the middle in order to clearly distinguish between acceptable and unacceptable air quality (Wargocki, 2004b).

During each round of assessments, three filter conditions were installed in three field labs and subsequently evaluated. In the first round of assessments, three subjects were randomly assigned to enter the field labs, one subject at a time in each room. In the next round, three more subjects were randomly assigned to enter the labs. This procedure was repeated until all subjects had conducted assessments in all three rooms. Subsequently the filter conditions in the rooms were changed, and the assessments were repeated. The subjects were asked to take a deep breath in front of a fan in the well-ventilated corridor before entering the test rooms. After entering, they removed the flexible duct from the end of the ventilation unit, exhaled the corridor air, inhaled the air from the ventilation unit and subsequently assessed the quality of air based on their facial exposure. This procedure ensured that the same air was used as background before each evaluation. The subjects spent the time between the individual assessments in a well ventilated room adjacent to the test rooms. The randomization of subjects was constrained by the requirement that each subject had to wait at least 3 rounds (approximately 3 minutes) between his/her individual assessments. At the end of each of the two days on which assessments were performed the subjects assessed the quality of the room air. This was done in order to evaluate the quality of the air before it entered the test plenum.

**Table 1.** Filter sets evaluated for sensory pollution after ~5 months of continuous service in outdoor test plenums operated at 1300 m<sup>3</sup>/hr

Set No.	1 <sup>st</sup> filter	2 <sup>nd</sup> filter	3 <sup>rd</sup> filter	Key to x-axis on Figure 3	Comments
1	EU7/F7 fiberglass, bag-type	-	-	1.EU7	Common configuration
2	EU4/G4 pleated 2" panel*	EU7/F7 fiberglass, bag-type	-	2.Pre-f.+Eu7	Fraction of the sensory offending pollutants on the pre-filter
3	Activated carbon, V-cell cartridge**	EU7/F7 fiberglass, bag-type	-	3.AC+EU7	1 <sup>st</sup> filter (AC) anticipated to reduce ozone chemistry on 2 <sup>nd</sup> filter
4	EU7/F7 fiberglass, bag-type	Activated carbon, V-cell cartridge**	-	4.EU7+AC	2 <sup>nd</sup> filter (AC) anticipated to remove fraction of sensory offending pollutants from 1 <sup>st</sup> filter
5	Activated carbon, V-cell cartridge**	EU7/F7 fiberglass, bag-type	Activated carbon, V-cell cartridge**	5.AC+EU7+AC	Benefits of AC filters in both set No.3 and No. 4
6	EU7/F7 with activated carbon-containing fiberglass media; bag-type***	-	-	6.EU7 w/AC bag-type (fiberglass)	AC may reduce surface chemistry and capture sensory offending pollutants
7	EU7/F7 pleated synthetic fiber with activated carbon; V-cell cartridge****	-	-	7.EU7 w/AC cartridge (synthetic)	AC may reduce surface chemistry and capture sensory offending pollutants
8	EU5/F5 fiberglass, bag-type	-	-	8.EU5	Common configuration

\* Exchanged monthly, assessments conducted with the last one-month-old pre-filter

\*\* No particle removal properties, total shipping weight ~5.5kg, estimated nominal weight of activated carbon ~1.7kg

\*\*\* Bag-type fibrous particulate filter containing activated carbon, total shipping weight ~3.5kg, estimated nominal weight of activated carbon ~1.3kg

\*\*\*\* Pleated V-Cell particulate filter containing activated carbon, total shipping weight ~5.5kg, estimated nominal weight of activated carbon ~1.3kg

## Results

Results of the filter weighings and measurements of pressure drops are shown in Table 2. During the five months of service, all of the particle filters (EU4 panel, EU5 and EU7 bag-type) gained weight, while all of the cartridge-type filters that contained activated carbon, including the combination filter (EU7 with AC, No. 7), lost weight. The bag-type combination filter (EU7 with AC, No. 6) increased in weight; however, only by about half of what had been gained by a EU7 filter positioned as the first filter in the system (see set No. 6 versus sets No. 1 and 4). The mass of particles collected on the surface of a stand-alone EU5 filter (No. 8) was only about 60% of that collected by an EU7 filter positioned as the first filter in the system (No. 1 and 4). Protecting a regular EU7 filter by either a pre-filter (set No.



2) or an activated carbon filter (sets No. 3 and 5) resulted in a significantly smaller increase in filter weight during the 5-month period. In set No. 2 it is important to note that the weight gain for the EU4 pre-filter (14 g) is for a one-month interval, since the pre-filter was changed monthly. In the case of the cartridge-type activated carbon filters, the lowest weight loss was observed for the activated carbon filter downstream of an identical activated carbon filter and an EU7 filter (set No. 5). The other cartridge filters containing AC lost considerably more weight -- between ~130 and 230 grams.

Over the 5-month period there was only a small increase in the pressure drop across each individual filter. The highest increase, nearly 30 Pa, was observed for the EU7 combination cartridge filter that contained activated carbon (No.7). There was an increase of ~15 Pa or less for the rest of the filters, while in two cases (sets No.6 and 8) a small decrease from the initial pressure drop was observed by the end of the soiling period. Configurations with two or three filters (sets No. 2 – 5) had higher combined initial and final pressure drops than sets with stand-alone EU5 or EU7 filters (sets No. 1 and 8). However, the pressure drop across an EU7 filter in series with an AC cartridge filter (sets No. 3 and 4) was not much greater than that across an EU7 filter in series with a pre-filter (set No. 2). The pressure drop across the bag-type combination filter (EU7 with activated carbon, No. 6) was also comparable to that across an EU7 filter in series with a pre-filter. Its pressure drop remained relatively constant over the 5-month period.

**Table 2.** *Weights and pressure drops for the filters prior to and after the 5-month service interval*

Set. No.	Filter position	Filter type	Initial weight (g)	Weight after 5 months (g)	Weight difference (g)	Initial pressure drop $\pm$ SD (Pa)	Pressure drop after 5 months $\pm$ SD (Pa)	Pressure drop difference (Pa)
1	1 <sup>st</sup>	EU7; bag	1218	1336	118	52 $\pm$ 3.2	61 $\pm$ 2.9	9
2	1 <sup>st</sup>	EU4; panel	460*	474**	14	24 $\pm$ 1.7***	33 $\pm$ 1.8****	9
2	2 <sup>nd</sup>	EU7; bag	1202	1261	59	67 $\pm$ 0.74	78 $\pm$ 1.6	11
3	1 <sup>st</sup>	AC; cartridge	5947	5771	-176	48 $\pm$ 1.0	59 $\pm$ 1.4	11
3	2 <sup>nd</sup>	EU7; bag	1203	1272	69	70 $\pm$ 0.56	86 $\pm$ 1.0	16
4	1 <sup>st</sup>	EU7; bag	1201	1317	116	52 $\pm$ 1.4	65 $\pm$ 3.5	13
4	2 <sup>nd</sup>	AC; cartridge	6053	5821	-232	49 $\pm$ 0.74	57 $\pm$ 0.83	8
5	1 <sup>st</sup>	AC; cartridge	5719	5585	-134	52 $\pm$ 1.3	52 $\pm$ 2.3	0
5	2 <sup>nd</sup>	EU7; bag	1220	1265	45	75 $\pm$ 0.91	86 $\pm$ 1.2	11
5	3 <sup>rd</sup>	AC; cartridge	5766	5733	-33	48 $\pm$ 0.53	50 $\pm$ 0.52	2
6	1 <sup>st</sup>	Combined EU7 with AC; bag	3459	3519	60	110 $\pm$ 2.7	102 $\pm$ 3.0	-8
7	1 <sup>st</sup>	Combined EU7with AC; cartridge	5451	5297	-154	123 $\pm$ 1.6	151 $\pm$ 3.9	28
8	1 <sup>st</sup>	EU5; bag	692	767	75	34 $\pm$ 2.0	30 $\pm$ 2.0	-4

\* average from 3 new pre-filters; \*\* average from four 1-month old pre-filters; \*\*\* average pressure drop  $\pm$  average standard deviation from five new pre-filters; \*\*\*\* average pressure drop  $\pm$  average standard deviation from five 1-month old pre-filters

Figure 3 shows the results of the sensory assessments of air that has passed through both used and new filters. The distribution of data was tested for normality with the Shapiro–Wilk’s test. Only data obtained for two out of the twenty-four test conditions were not normally distributed ( $p < 0.01$ ). Differences between assessments were tested for statistical significance using analysis of variance ANOVA (when data normally distributed) or the Wilcoxon signed

rank test (when data not normally distributed). No significant differences were found between assessments of the empty test plenums. The mean acceptability obtained for air downstream of the three empty test plenums was +0.34; this is shown as a line in Figure 3.

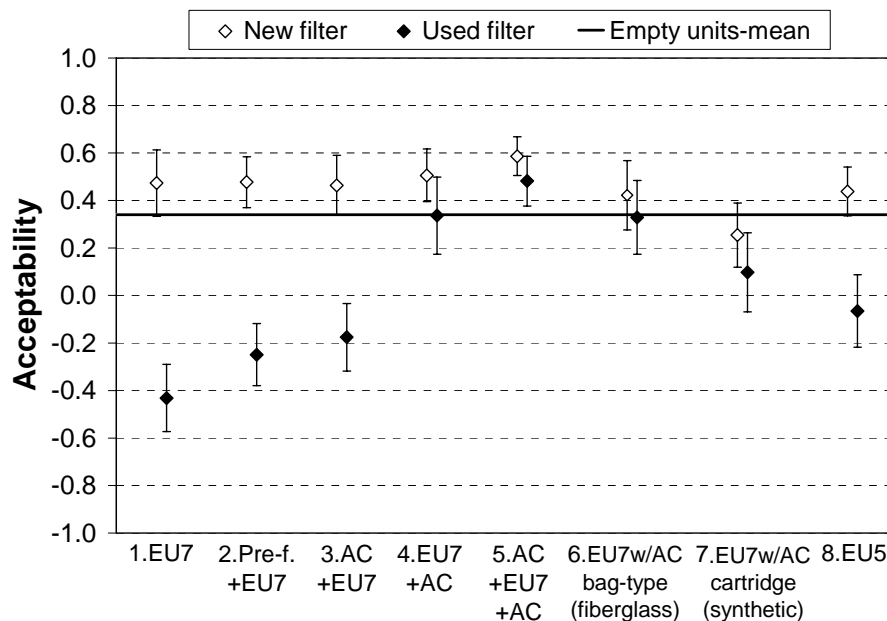

**Figure 3.** Acceptability of air downstream of the new and used filters or filter combinations. Mean assessed values and 95% confidence intervals are shown. The solid line depicts the mean acceptability assessed for air that had passed through the three empty test plenums. See Table 1 for key to x-axis labels

On average, the quality of air in the three test rooms was assessed as almost identical with the air from the empty test plenums (acceptability of 0.37 vs. 0.34, respectively). The acceptability of air downstream of the new filters was slightly higher than the acceptability of air that passed through the empty units. The only exception was the new synthetic fiber EU7 filter that incorporated activated carbon (No. 7 in Table 1), which showed significantly lower acceptability than the rest of the new filter combinations ( $P < 0.05$ ). Air passing through the test plenum that contained a new AC filter both up- and downstream of the new EU7 filter (No.3) was evaluated as the most acceptable. However, new set No. 3 differed in a statistically significant way only when compared with the new stand-alone EU5 filter (No.8;  $P < 0.05$ ) and the new stand-alone synthetic EU7 filter that incorporated activated carbon (No.7;  $P < 0.01$ ).

After 5 months of continuous operation each of the used filters adversely affected the quality of the air passing through them. However, there were substantial differences in the magnitude of the effects observed. The subjects assessed the air downstream from the stand-alone EU7 fiberglass bag filter (No. 1) to be worse than air downstream from all of the other filter combinations ( $P < 0.01$ ). Results obtained for the EU7 filter that had a one-month old pre-filter (No.2) or an active carbon filter (No.3) in front, showed significant improvement in air quality relative to the stand-alone used EU7 filter ( $P < 0.01$ ). However, the air downstream of these filter combinations remained somewhat unacceptable (-0.25 and -0.18, respectively). Air that had passed through filter sets that included an AC filter either downstream (No.4) or both up- and downstream of an EU7 filter (No.5) was judged to be as acceptable or better than air that had passed through the empty test plenums. A very similar evaluation was obtained

for air that had passed through the EU7 fiberglass bag filter that contained activated carbon (No.6). These three combinations (No. 4, 5 and 6) were perceived as significantly better than the rest of the tested filters ( $P<0.01$ ), with no statistically significant differences among them ( $P>0.05$ ). The perceived air quality downstream of the used synthetic fiber EU7 filter that incorporated activated carbon (No. 7) was significantly worse than that from sets No. 4, 5 and 6 ( $P<0.01$ ), but better than that from the first three sets ( $P<0.05$ ). However, the negative assessment for No. 7 reflected the fact that the filter had an adverse impact on the quality of air passing through it when it was new, rather than degradation during its 5 months of service. In fact, in the case of No. 7, the assessments of the new and used filter are not significantly different ( $P>0.05$ ). Air passing through the used stand-alone EU5 filter (No.8) was less acceptable (-0.07) than when this filter was new. Still, the air downstream of this filter was more acceptable than that downstream of the stand-alone EU7 filter or the EU7 filter protected by a pre-filter ( $P<0.05$ ).

## Discussion

Prior to this study, we felt that new approaches would be required if particles were to be removed from ventilation air without adversely affecting the resulting quality of the delivered air. The results reported in Figure 3 suggest otherwise. They indicate that methods already exist, using commercially available filters, to remove particles without significantly degrading the quality of the air that passes through the filtration media. In the following paragraphs we discuss these results in greater detail, beginning with the weight changes and concluding with the most important findings to come out of the current studies – the sensory assessments.

### *Weight change*

The weight gains measured for the particle filters after five months of service are consistent with their nominal filtration efficiencies and relative position in the test plenum (when present with other filters). For example, when positioned as the first filter, EU7 bag filters gained 115 to 120 g (Nos. 1 and 4) while the less efficient EU5 gained 75 g (No. 8). When protected by a pre-filter, the EU7 bag filter only gained 59 g (No. 2). When protected by an activated carbon filter, not designed to remove particles, the EU7 bag filter still gained only 69 g (No. 3).

Each of the activated carbon cartridge filters (Nos. 3 – 5) lost weight during their five months of service. Presumably, most of this weight loss is due to small particles of carbon that break off from the carbon granules in the cartridge filter and are subsequently removed by the air passing through the filter. This process is referred to as “dusting”. However, it is somewhat surprising that the EU7 bag filters located downstream of AC carbon filters, that are presumably “dusting”, have not gained more weight than they have (69 g and 45 g in sets No. 3 and 5, respectively). A second mechanism that can contribute to weight loss is oxidation of carbon bonds on the surface of the carbon, followed by carbon-carbon bond scission and release of carbon monoxide or carbon dioxide. With this mechanism in mind, the weight changes measured for the two AC filters in set No. 5 are interesting. The AC filter in front lost 134 g while the AC filter in back lost only 33 g; the AC filter in back had significantly less ozone passing through it than did the one in front. We have calculated the weight loss that could occur from oxidation based on the assumption that ozone, at an average ambient concentration of 30 ppb, was the primary oxidant of surface carbon on the AC. The resulting estimate indicates that ~ 60 g is the maximum anticipated weight change over 5-months of

service. This is insufficient to fully explain the results in Table 2; it appears that a combination of dusting and oxidation are responsible for the measured weight changes among the AC cartridge filters.

The weight changes measured for the two combination filters (Nos. 6 and 7) are sharply different from each other. Both filters are rated EU7 and, based on the results from sets No. 1 and 4, are anticipated to have removed slightly more than 100 g of particles from the airstream during their time in service. However, both filters are also anticipated to have lost mass from the activated carbon that they contain. The EU7 bag filter that incorporates AC gained 60 g (No. 6), while the EU7 cartridge filter that incorporated AC lost 154 g (No. 7). These results are consistent with “dusting” as the cause of weight loss. Given the construction of the EU7/AC bag filter compared to the EU7/AC cartridge filter, carbon particles that break off from the carbon granules are more likely to be captured by the former.

### *Pressure drop*

The initial pressure drops across the particle filters match what is anticipated from their filtration efficiencies (i.e., EU7 > EU5 > EU4). The initial pressure drop across the AC cartridge filters was almost as large as those across the EU7 bag filters. In the case of the combination filters, their initial pressure drops were comparable to one another, and roughly twice as large as those across the EU7 bag filters. When the different sets of filters are compared, set No. 5 with an EU7 filter between two AC cartridge filters had the highest initial pressure drop (175 Pa). The sets that had one AC cartridge filter, No. 3 and 4, had total initial pressure drops (118 and 101 Pa) that were comparable to the initial pressure drops of the combination filters in sets No. 6 and 7 (110 and 123 Pa).

The differences between initial and final pressure drop measurements should be interpreted cautiously, since these were made outdoors on days that were 5-months apart and may be influenced by differences in air temperature, humidity, and wind conditions. The EU7 cartridge filter that incorporated AC displayed the largest pressure drop increase (28 Pa), while the other combination filter, the EU7 bag filter with AC, showed a slight pressure decrease. This decrease is likely an artifact caused by differences in weather conditions on the days when the initial and final pressure drops were measured. The pressure drop across EU7 bag filters increased 10 to 15 Pa. The AC cartridge filters spanned a range from almost no increase to an increase of 11 Pa, with no apparent trend.

### *Sensory assessments*

The mean acceptability for air downstream of the three empty test plenums, 0.34, was similar to that of the room air, 0.37, indicating that emissions from the test plenums themselves had a negligible influence on the sensory assessments of new and used filters. With the exception of the synthetic fiber cartridge filter with AC, the perceived quality of air downstream of the new filters was slightly better than that of the air passing through the empty test units (see Figure 3). The new filters may have sorbed a fraction of the sensory offending pollutants present in the ambient air. It is not clear why air passing through the new synthetic fiber cartridge filter with AC (No. 7) was perceived to be less acceptable than air passing through the new filters with fiberglass media. Presumably emissions from the synthetic media, and not the relatively low emitting polypropylene housing, were responsible for the results.

After 5 months of service, air passing through the stand-alone EU7 filter was judged to be less acceptable than air passing through any of the other filters or filter combinations. When a pre-filter was installed upstream of an EU7 filter, the air passing through this combination was judged to be more acceptable than that passing through a stand-alone EU7 filter. Note that the pre-filter in this combination was replaced monthly. Hence, every time a pre-filter was replaced, ~15 g of captured coarse particles were removed from the filter set (see Table 2). It is interesting to compare sensory assessments and weight gains for the used EU5 filter (No. 8) and the combination of an EU4 pre-filter followed by an EU7 filter (No. 2). The mean assessments indicated that air passing through the used EU5 was more acceptable than that passing through the pre-filter/EU7 combination. The mass gained by the used EU5 filter was almost the same as the total mass gained by the one-month old pre-filter and 5-month EU7 filter (75 g vs. 73 g). However, the EU7 filter captures a greater fraction of submicron particles than does an EU4 pre-filter or an EU5 filter, and the total surface area of the 73 g of particles captured by the pre-filter/EU7 combination was presumably larger than the total surface area of the 75 g of particles captured by the EU5 filter. Given the ranking of the sensory assessments, this suggests that acceptability depends more on the total surface area of the captured particles than on the total mass of the captured particles. (Although the air passing through the used EU5 filter was perceived to be more acceptable than that passing through the pre-filter/EU7 combination, the former captures fewer particles from the air that passes through and offers less protection for HVAC equipment and occupants downstream of the filters.)

Placing an activated carbon filter upstream of an EU7 bag filter (No. 3) improved the acceptability of air passing through the used filters only slightly more than placing a pre-filter upstream of an EU7 filter (No. 2). However, the pre-filters were replaced monthly, while the AC filter remained in place throughout the 5 months. The AC filter presumably removed some of the larger particles from the airstream (see above), some of the gas-phase organic compounds and a significant fraction of the ozone (see Introduction). The ozone removal means that less ozone passed through the downstream EU7 filter, and less oxidation chemistry occurred on the surface of this filter (Bekö et al., 2006). The fact that this filter set, although better than a stand-alone EU7, was still judged to be relatively unacceptable suggests that oxidation of organics associated with captured particles is not the dominant factor responsible for the sensory pollutants emitted from this combination of used filters.

Placing an activated carbon filter downstream of an EU7 bag filter (Nos. 4 and 5) produced a much larger improvement than placing an activated carbon filter upstream of an EU7 filter (see Figure 3). This indicates that the organics responsible for the deteriorated air quality were efficiently removed by the activated carbon filter. In set No. 4, the EU7 filter captured nearly 120g of particles and was not protected from ozone or other gaseous pollutants. Still, the perceived air quality downstream of this filter set after 5 months of service was nearly as good as that downstream of this set when the filters were new. The performance of the filter set with an activated carbon filter both up- and downstream of the EU7 bag filter (No. 5) was somewhat better. After 5 months of service, air passing through this combination of filters was judged to be more acceptable than air passing through any of the other filter combinations. The upstream carbon filter protected the EU7 filter from ozone, coarse particles and some organic compounds. However, the relatively large incremental difference between sets No. 3 and 5 (acceptabilities of -0.18 and +0.48, respectively) was due to the addition of the downstream carbon filter.

Surprisingly good results were obtained for the fiberglass EU7 bag filter that incorporated activated carbon (No. 6). The acceptability of air downstream of this filter was as high as that downstream of filter sets that contained an activated carbon filter downstream from the EU7 bag filter (No. 4 and 5). Although this filter is constructed in a manner that is analogous to a standard EU7 fiberglass bag filter, the inclusion of activated carbon appears to result in effective removal of offending pollutants that emanate from the captured particles.

The other combination filter, the synthetic fiber EU7 cartridge filter that contained activated carbon (No.7) was expected to produce results similar to its bag-type fiberglass equivalent (No.6). The assessments, however, revealed significantly poorer air quality downstream from this synthetic-media combination filter than downstream from the fiberglass-media combination filter (acceptability of 0.10 compared with 0.33). This difference between the combination filters was almost entirely due to the difference between these filters when they were new. After 5 months of service, the change in acceptability for these two combination filters was comparable. In either case, incorporating activated carbon significantly reduced the emission of sensory offending pollutants that occurs as filters accumulate captured particles from the airstream.

The sensory assessments in these evaluations were conducted with one-tenth of the airflow used during the 5 month soiling period (130m<sup>3</sup>/h vs. 1300 m<sup>3</sup>/h). The relative differences among the filter sets are not anticipated to be meaningfully altered by the reduced airflow. Based on previous studies, this also may be true for the absolute values derived from the sensory assessments. Alm et al. (2000) demonstrated that increasing the outdoor airflow rate through a used filter increased the emissions from a used filter and that the acceptability of the downstream air changed very little. Using an expanded range of airflows, Strøm-Tejsen et al. (2003) reported similar observations and confirmed the proportional relationship between pollution load and rate of airflow through a used filter.

The used filters examined in the present study were in service during autumn and winter months. The outdoor temperatures during this period were cooler than the indoor temperatures during the two days of assessments. These higher indoor temperatures may have promoted desorption of sensory pollutants from the used filters. Regardless, the relative differences among these 8 sets of filters are striking. A potentially larger issue concerns variations (with season, location and source of captured particles) in the nature of sensory offending pollutants emitted by used filters. An especially pronounced difference is anticipated for filters that have been soiled exclusively with outdoor air compared to filters that are used downstream of the mixing box in a recirculating air system. In the latter case, the filters are soiled with a large fraction of indoor air, which often contains elevated concentrations of organic pollutants not commonly encountered outdoors. This includes emissions from cleaning products, paints, polishes and various floor and wall coverings (Brown et al., 1994; Hodgson and Levin, 2003). The less volatile of these emissions will sorb to the surface of the soiled filter and also be associated with particles captured by the used filter, resulting in sensory offending pollutants that may differ significantly from those in the present study. Still another issue is the time-interval over which the activated carbon filters will continue to remove sensory offending pollutants. The present study indicates excellent performance over a period of 5 months, but would such performance continue for a year or more? How frequently do such filters have to be changed and how does this vary with soiling conditions? Hence, it is important to extend these studies to other situations before large-scale implementation of mitigation procedures suggested by Figure 3.

The EU7 filter followed by an activated carbon filter downstream and the stand-alone EU7 bag filter that contains activated carbon both performed well in terms of acceptable perceived air quality achieved at a reasonable overall pressure drop. Particularly promising is the bag-type combination filter, which had a pressure drop after 5 months of service that was lower than that of any of the other sets evaluated except the stand-alone EU7 and EU5. The bag-type combination filter does not require modification of filter housings if the housing already accepts standard bag filters. An additional advantage of activated carbon, whether in a cartridge filter or in a combination filter, is its ability to remove ozone from the supply air, which may have meaningful health benefits (Weschler, 2006). cursory measurements of the ozone removal efficiency of the used bag-type combination filter indicated better than 85% removal at various airflows even after 5 months of continuous operation.

## **Conclusions**

Activated carbon filters downstream of particle filters in HVAC systems can meaningfully improve the acceptability of the filtered air. Of the two combination filters, the synthetic fiber filter that contained activated carbon suffered from emission of sensory offending pollutants when it was new, and this appeared to remain the case after five months of service. Conversely, the fiberglass bag filter that contained activated carbon improved the acceptability of the filtered air as much as an activated carbon filter downstream of a particle filter. Furthermore, its pressure drop changed very little during the five months of service and, based on preliminary measurements, it removed a large fraction of ozone from the airstream even after 5 months of continuous operation. Additional experiments are warranted to explore the generality of these striking results before wide scale adoption of such filters can be recommended. If further experiments produce similar results, combination filters that incorporate activated carbon could replace commonly used bag filters. Such filters would have particle removal efficiencies comparable to standard bag filters, would remove sensory offending pollutants and would have the added bonus of removing a significant fraction of ozone from the airstream. This would mean improvements in air quality with little or no modification to the air handling system and with only a modest additional expense in filter cost and fan energy.

## **Acknowledgements**

This work has been supported by the Danish Technical Research Council (STVF) as part of the research program of the International Centre for Indoor Environment and Energy established at the Danish Technical University (DTU) for the period 1998-2007. The authors thank Fang Lei and Jørn Toftum from DTU for their constructive comments during the preparation of the experiments and Camfil Farr for providing the filters and the filter housings. Thanks are due to Thomas Pedersen, Peter Simonsen and Erik Christiansen for their help with assembling the test plenums.

## **References**

Alm, O. (2001) *Ventilation filters and their impact on human comfort, health and productivity*, Doctoral Dissertation (PhD thesis MEK-I-Ph.D. 01.02), International Centre for Indoor Environment and Energy, Technical University of Denmark, Lyngby.

- Alm, O., Clausen, G. and Fanger, P.O. (2000) "Exposure-response relationships for emissions from used ventilation filters", In: *Proceedings of Healthy Buildings 2000*, Vol. 2, pp. 245–250.
- Bekö, G., Halás, O., Clausen, G., Weschler, C.J. (2006) "Initial studies of oxidation processes on filter surfaces and their impact on perceived air quality", *Indoor Air*, **16**, 56-64.
- Bekö, G., Clausen, G., Weschler, C.J. (2007) "Further studies of oxidation processes on filter surfaces: evidence for oxidation products and the influence of time in service", *Atmospheric Environment* (in press).
- Brown, S., Sim, M., Abramson, M., Gray, C. (1994) "Concentrations of volatile organic compounds in indoor air -- a review", *Indoor Air*, **4**, 123-134.
- Clausen, G., Alm, O. and Fanger, P.O. (2002) "The impact of air pollution from used ventilation filters on human comfort and health", In: *Proceedings of the 9th International Conference on Indoor Air Quality and Climate Indoor Air 2002*, Monterey, CA, USA, Vol. 1, 338–343.
- Clausen, G. (2004) "Ventilation filters and indoor air quality: a review of research from the International Centre for Indoor Environment and Energy", *Indoor Air*, **14**, **S7**, 202-207.
- Fisk, W. J., Faulkner, D., Palonen, J., Seppänen, O. (2002) "Performance and costs of particle air filtration technologies", *Indoor Air*, **12**, 223-234.
- Hodgson, A. T., Levin, H. (2003) *Volatile Organic Compounds in Indoor Air: A Review of Concentrations Measured in North America Since 1990*; LBNL-51715; Lawrence Berkeley National Laboratory: Berkeley, CA, 31 pp.
- Hyttinen, M., Pasanen, P., Kalliokoski, P. (2001) "Adsorption and desorption of selected VOCs in dust collected on air filters", *Atmospheric Environment*, **35**, 5709-5716.
- Hyttinen, M., Pasanen, P., Salo, J. et al. (2003) "Reactions of ozone on ventilation filters", *Indoor and Built Environment*, **12**, 151-158.
- Hyttinen, M., Pasanen, P., Kalliokoski, P. (2006) "Removal of ozone on clean, dusty and sooty supply air filters", *Atmospheric Environment*, **40**, 315-325.
- Hyttinen, M., Pasanen, P., Björkroth, M., Kalliokoski, P. (2007) "Odors and volatile organic compounds released from the ventilation filters", *Atmospheric Environment*, **41**, **19**, 4029-4039.
- Møhlhave, L., Thorsen, M., (1991) "A model for investigations of ventilation systems as sources for volatile organic compounds in indoor climate", *Atmospheric Environment*, **25a**, 241-249.
- Mysen M., Clausen G., Bekö G., Halas, O. (2003) "The influence of typical ways of operating an air-handling unit on the sensory pollution load from used bag filters", In: *Proceedings of Healthy Buildings 2003*, Singapore, Vol. 3, 267-272.
- Mysen, M., Magnussen, K., Nilsen, S.K., Schild, P.G. (2006) "Emissions from different types of used ventilation bag filters and their impact on perceived air quality", In: *Proceedings of Healthy Buildings 2006*, Lisbon, Portugal, Vol.4, 471-474.
- Pasanen, P., Teijonsalo, J., Seppänen, O. et al. (1994) "Increase in perceived odor emissions with loading of ventilation filters", *Indoor Air*, **4**, 106-113.
- Pasanen, P. (1998) *Emissions from filters and hygiene of air ducts in the ventilation systems of office buildings*, Doctoral dissertation, Kuopio University Publications C. Natural and Environmental Sciences 80, 1-77.
- Pejtersen, J., Bluysen, P., Kondo, H., Clausen, G. and Fanger, P.O. (1989) "Air pollution sources in ventilation systems", In: *Proceedings of CLIMA 2000*, Sarajevo, August 1989, Vol. 3, 139–144.
- Pejtersen, J. (1996) "Sensory pollution and microbial contamination of ventilation filters", *Indoor Air*, **6**, 239–248.



- Shair, F.H. (1981) "Relating indoor pollutant concentrations of ozone and sulfur dioxide to those outside: Economic reduction of indoor ozone through selective filtration of the make-up air", *ASHRAE Transactions*, 87(I), 116-139.
- Shields, H.C., Weschler, C.J., Naik, D.V. (1999) "Ozone removal by charcoal filters after continuous extensive use (5 to 8 years)", In: *Proceedings of Indoor air 1999*, Construction communications Ltd., London, Vol.4, 49-54.
- Strøm-Tejse, P., Clausen, G. and Toftum, J. (2003) "Sensory pollution load from a used ventilation filter at different airflow rates", In: *Proceedings of Healthy Buildings 2003*, Singapore, Vol. 3, 257–261.
- Wargocki, P., Wyon, D.P., Fanger, P.O. (2004a) "The performance and subjective responses of call-centre operators with new and used supply air filters at two outdoor air supply rates", *Indoor Air*, **14**, **S8**, 7-16.
- Wargocki, P. (2004b) "Sensory pollution sources in buildings", *Indoor Air*, **14**, **S7**, 82-91.
- Weather Underground. (2007) *Weather history for Copenhagen, Denmark*. Accessed via Weather Underground ([www.wunderground.com](http://www.wunderground.com)).
- Weschler, C.J., Shields, H.C., Naik, D.V. (1993) "An evaluation of activated carbon filters for the control of ozone, sulfur dioxide and selected volatile organic compounds", In: *Proceedings of Indoor Air Quality 1992, Environment for people, ASHRAE*, 233-241.
- Weschler, C.J., Shields, H.C., Naik, D.V. (1994) "Ozone-removal efficiencies of activated carbon filter after more than three years of continuous service", *ASHRAE Transactions* **100**, Part 2, 1121-1129.
- Weschler, C.J. (2003) "Indoor/outdoor connections exemplified by processes that depend on an organic compound's saturation vapor pressure", *Atmospheric Environment*, **37**, 5455–5465.
- Weschler, C.J. (2004) "Chemical reactions among indoor pollutants: what we've learned in the new millennium", *Indoor Air*, **14**, **S7**, 184-194.
- Weschler, C. J. (2006) "Ozone's impact on public health: contributions from indoor exposures to ozone and products of ozone-initiated chemistry", *Environmental Health Perspectives*, **114**, 1489-96.
- Wyon, D.P., Tham, K.W., Croxford, B. et al. (2000) "The effects on health and self-estimated productivity of two experimental interventions which reduced airborne dust levels in office premises", In: *Proceedings of Healthy Buildings 2000*, Espoo, Vol. 1, 641-646.
- Zhao, P, Siegel, JA, Corsi, RL. (2007) "Ozone removal by HVAC filters", *Atmospheric environment*, **41**, 15, 3151-3160
- Zhao, P. (2006) *Ozone interactions with HVAC filters*. Doctoral dissertation, University of Texas at Austin, December 2006.

#### **4.5 Factors affecting the accuracy of measuring the pressure drop over ventilation filters**

**Paper to be published in:**

The International Journal of Ventilation

**Publisher:**

VEETECH Ltd.

**Paper submitted on:**

30 May, 2007

# **Factors Affecting the Accuracy of Measuring the Pressure Drop over Ventilation Filters**

Gabriel Bekö<sup>1,2</sup>

<sup>1</sup>Faculty of Civil Engineering, Department of Building Services, Slovak University of Technology, Radlinského 11, 813 68 Bratislava, Slovakia

<sup>2</sup>International Centre for Indoor Environment and Energy, Department of Mechanical Engineering, Technical University of Denmark, Nils Koppels Allé, Building 402, DK-2800 Lyngby, Denmark

Corresponding author:

Gabriel Bekö  
International Centre for Indoor Environment and Energy  
Technical University of Denmark  
Nils Koppels Allé, Building 402  
DK-2800 Lyngby, Denmark  
Phone: (+45) 45 25 40 18, fax: (+45) 45 93 21 66  
E-mail: gb@mek.dtu.dk

## **Abstract**

Accurate measurement of pressure drop over ventilation filters is important to maintain the filter banks correctly and decrease the associated costs. The effect of various HVAC ductwork components upstream of a filter unit on the measured pressure loss across a fibrous filter was studied. Static pressure upstream of the filter was measured at ~2 cm from the filter frame. The downstream measurements were made either at the same distance from the filter frame or ~65 cm from the upstream sensor. The results obtained at the latter position seemed to be generally more stable and accurate. When the ventilation unit was variously modified upstream of the filter, the measured pressure drop varied between 3 and 91 Pa, depending also on the location of the pressure sensors. The results suggest that for exact determination of the filter pressure drop the application of bends or dampers directly upstream of the filter housing should be avoided. These measurements were conducted with single up- and downstream pressure-sensing rubber tubes with tips inserted ~2 cm through the duct wall. The pressure drop was measured also with 10 mm diameter metal tubes that had six 2 mm diameter holes on the downstream side. Two vertical probes were symmetrically placed upstream of the filter and two downstream of the filter. Their length was consistent with the height of the filter box. With this method, rather stable and accurate readings were achieved, regardless the unit modifications. Further research is required before practical application of the method may be considered.

## **Key words**

Ventilation filter, Pressure drop, Static pressure, Sensor, Accuracy

## **1. Introduction**

Filters in heating, ventilation and air-conditioning (HVAC) systems, which remove dust and contaminants from the air passing through the system, play a key role in the energy consumption of the systems (Matela, 2006). The energy costs associated with overcoming the filters' pressure drop are significantly greater than the materials and labour costs associated with filters (Weschler, 1991). The increase in pressure drop is the major criterion used today to determine the frequency of filter exchange. Operators usually change filters after the resistance rises to between two and three times the initial pressure drop (Carrier et al., 1959). Fisk et al. (2002) explored the trends in total life cycle costs when the final pressure drop of filters decreased from the manufacturer's recommended values. The study concluded that replacing the filter more frequently could in some cases save energy. Although information is lacking in the technical and scientific literature as regards the importance of accurate determination of pressure drops over ventilation filters, conducting thorough monitoring seems to be important.

Factors that affect the pressure drop of a filter are fluid viscosity, fluid-specific gravity, flow rate, filter element medium and flow passages (BS 6277, 1982; Fain, 1986). However, factors influencing the accuracy of pressure drop measurements in practice, such as the effect of different duct connections to the filter housing are not well documented. Studies testing the pressure drop across ventilation filters (Weingartner et al., 1996) normally use stable laboratory conditions and do not describe the pressure measurements in great detail. Standards exist for the laboratory testing of airflow resistance of filtration media (ASTM, 2001), but, standards regarding the monitoring of filter pressure losses in real heating ventilation and air-conditioning units are missing. Recommendations are available only in

connection with the performance of filters. Such recommendations include uniform flow through the entire filter area, gradually sloped transitions upstream and downstream of the filter, minimal abrupt changes in direction of airflow to avoid eddy currents through the filter, or dead air spaces in the filter housing (ASHRAE, 1988). Although these requirements no doubt contribute to the conditions suitable for accurate pressure sensing, they are often not met due to space limitations around the ventilation units.

Additional recommendations are provided by manufacturers of pressure sensors. The type of static pressure tips used and their location is of primary importance in securing reliable readings (Dwyer, 2006a). For maximum accuracy of sensing the static pressure upstream and downstream of the filter, it is essential to eliminate the influence of the air velocity. Right-angle static pressure tips give rather accurate sensing (Dwyer, 2006b). They sense static pressure through radially-drilled holes near the tip, which is located away from the duct walls. Static pressure fittings perpendicular to the flow are low in cost and unlikely to plug up, but are more susceptible to the influence of velocity and turbulence. One such sensor, very often used in real HVAC systems, is the U-tube manometer, half filled with liquid. The legs are connected to an opening through the duct wall. This type of sensor should be used where airflow is relatively slow, smooth and without turbulence. If turbulence exists, as is often the case in practice, impingement, aspiration or uneven distribution of moving air, can reduce the accuracy of readings significantly. Static tips are often recommended to be located at least 30 cm upstream and downstream from the filters in a zone of minimum turbulence. Moreover, multiple pressure sensors located 90 degrees apart and manifolded together are preferred over a single sensor in laboratory tests of filter materials (ASTM, 2001). However, in practice, only single sensors are used, and they are usually incorrectly placed directly before and after the frame of the filter.

The present study examined the influence of the location of pressure sensors on the accuracy of filter pressure drop measurements. The paper describes two methods of pressure sensing that were tested on a ventilation unit that was modified in various ways upstream and downstream of the filter.

## 2. Methods

The pressure drop over a new 0.6 x 0.3 m EU7 fibreglass pocket filter was measured at various modifications of a simple ventilation unit located outdoors. The unit consisted of a 0.6 x 0.3 m filter housing, reductions to 250 mm diameter circular duct, damper to regulate the airflow, and connecting ductwork. An orifice (IRIS damper; accuracy of  $\pm 7\%$ ) to measure the airflow through the system and a circular duct fan were mounted at an appropriate distance downstream of the filter box (Figure 1). The airflow through the unit was adjusted to 1300 m<sup>3</sup>/h, which corresponds to a face velocity of 2 m/s in the filter box. The damper was approximately half open in the direction as indicated in Figure 1.

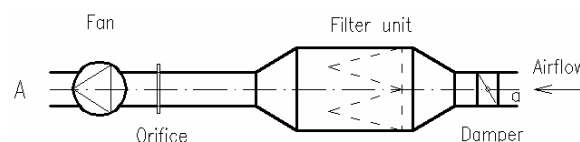

**Figure 1.** Ground view of the ventilation unit used for measurements of the filter's pressure drop. System A, shown here, was used for the initial set of measurements before the unit was modified

The pressure loss across the filter was measured by a Testo 511 temperature-compensated pressure meter. The accuracy of the instrument is  $\pm 3$  Pa for the range of measured values between 0 and 100 Pa. The pressure meter was connected to the static pressure sensing devices upstream and downstream of the filter via 6 mm diameter rubber tubes. Between 15 and 20 values in one-second intervals were recorded and averaged at each set of measurements. The instrument was zeroed before every set of measurements. All measurements were conducted during the same period of  $\sim 2$  hours, during which the air temperature (air viscosity) was not anticipated to change to an extent that could influence the results.

Five different positions of the upstream and downstream pressure-sensing points were tested (Figure 2). In the first case (position 1), two separate probes were tightly inserted through openings in the wall of the filter housing upstream of the filter and two downstream of the filter at the indicated distances. The probes (Figure 3) were made of hollow metal tubes with a 10 mm outer diameter. The length of the tubes was over 30 cm in order to cover the entire height of the filter box while inserted through its bottom wall. Six 2 mm diameter openings were drilled at identical distances from each other on one side of each tube. During the measurements, the perforated probes were used in a position where the holes were not facing the airflow in order to avoid the influence of velocity pressure on the results. The upper tips of the probes were blocked. The lower ends of the two upstream probes were connected to a single rubber tube leading to the manometer. The downstream probes were similarly connected with the instrument. The probes were thus used to measure the average static pressure over the cross-section of the filter box.

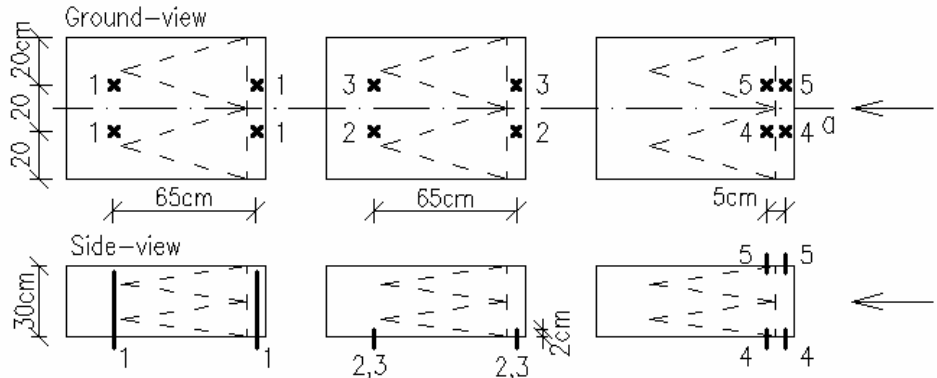

**Figure 2.** Tested positions of the upstream and downstream static pressure sensors

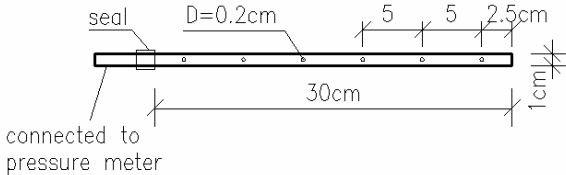
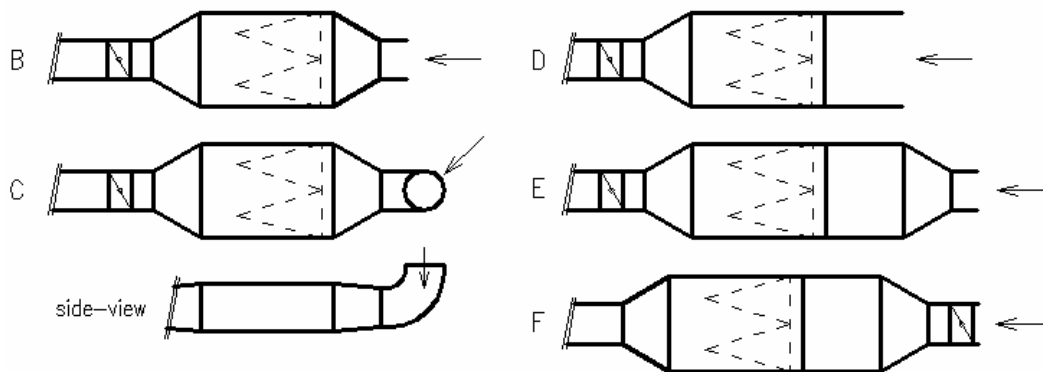

**Figure 3.** Perforated probe used for measuring static pressure upstream and downstream of the filter

The other four positions of the pressure sensors examined (positions 2-5) represented a technique most commonly used for pressure drop measurements in practice. We will generally call this technique the “2-point measurement”, as it utilizes one single opening in the wall of the filter box for measuring static pressure upstream of the filter and another one downstream of the filter. A 4 mm diameter rubber measuring tube connected to the pressure

meter was inserted through such an opening just upstream of the filter frame. Another tube was inserted downstream of the filter at either  $\sim 65$  cm from the upstream sensor (positions 2, 3) or directly next to the filter frame (positions 4, 5). The tips of these tubes were located at a distance of  $\sim 2$  cm from the wall of the filter housing. The openings around the measuring tubes were properly sealed. All openings used for the measurements were located on the bottom wall of the filter box except for measurements at sensor position 5, which were conducted through the top wall. When looking in the direction of the airflow, sensor positions 2 and 4 were located to the left of the filter box's centre axis "a" (see Figures 1 and 2), while positions 3 and 5 were on its right side.

After the first set of measurements at each position, several modifications of the initial unit (system A on Figure 1) were prepared, the airflow was readjusted and the measurements were repeated. In system B the damper was moved downstream of the filter. A  $90^\circ$  upward bend was added upstream of the filter on setup C. The upstream reduction was exchanged to a  $0.6 \times 0.3$  m rectangular duct of 500 mm length on system D. Unit E included the reduction to a circular duct upstream of the 500 mm long rectangular extension of the filter box. System F is similar to unit E; however, the damper was placed back to the inlet of the system. Additionally, system B was tested with no filter in place, in order to obtain the pressure drop of an empty filter box (system G). The modifications of the test rig are shown in Figure 4.



**Figure 4.** Five modifications (B through F) of the ventilation unit used for the measurements of pressure drop across a ventilation filter

### 3. Results and discussion

Table 1 lists the results of pressure measurements made at different locations of the pressure sensors for each modification of the ventilation unit. The measured pressure drop of the filter varied greatly with the position of the measuring point as well as with the construction of the ventilation unit upstream of the filter housing. The results fluctuated between 3 and 91 Pa for the same filter. Such inaccuracy may account for either too frequent or scarce filter exchange which can cause serious financial losses.

The actual value of the pressure drop of the tested filter was not precisely determined under laboratory conditions. According to the manufacturer, the nominal pressure drop of the filter used in this study is 105 Pa at an airflow of  $1700 \text{ m}^3/\text{h}$ . It corresponds to approximately 61 Pa at an airflow of  $1300 \text{ m}^3/\text{h}$ , when a linear relation between pressure loss and airflow is assumed. However, the relationship is in theory linear only under laminar flow conditions, whereas the conditions can often be turbulent. The coefficients of the filter (coefficient of discharge and expansion coefficient) are then difficult to establish with sufficient accuracy due to the filter's rather dynamic behaviour within the airstream under the various

experimental conditions. Moreover, filter media may undergo physical changes with changes in temperature and moisture (ASTM, 2001). The filter was not exposed to a standard conditioned atmosphere prior to and during the experiment. Therefore the estimated filter pressure drop corresponding to the adjusted airflow can be highly uncertain and not sufficiently representative of the filter’s real pressure drop at the given airflow. Hence, attention should not be paid to the deviation of the obtained pressure drops from the filter’s true pressure loss, but to the relative differences between the results obtained under various conditions. We assume that no physical changes of the filter media occurred during the entire period of the experiment.

**Table 1.** Pressure drop across the filter measured at five different locations at six various modifications of the ventilation unit. The pressure drop of an empty filter box is indicated in the last row of the table (system G). “Up” stands for upstream, “down” stands for downstream position of the respective unit component. The tested positions of sensors are simply described. See text and Figure 2 for details

System modification	Filter pressure drop $\pm$ standard deviation				
	1 Perforated probes	2 2-point, 65 cm dist., left	3 2-point, 65 cm dist., right	4 2-point, at frame, left	5 2-point, at frame, top wall, right
A. Damper + reduction up.	54 $\pm$ 1.89	30 $\pm$ 3.29	68 $\pm$ 3.93	3 $\pm$ 3.64	35 $\pm$ 3.61
B. Reduction up.; damper down.	57 $\pm$ 1.98	62 $\pm$ 4.54	66 $\pm$ 6.46	37 $\pm$ 5.50	45 $\pm$ 3.07
C. 90° bend + reduction up.; damper down.	68 $\pm$ 0.97	87 $\pm$ 1.77	91 $\pm$ 2.95	56 $\pm$ 1.46	50 $\pm$ 2.60
D. 0.6 x 0.3 duct up.; damper down.	75 $\pm$ 0.46	70 $\pm$ 0.80	71 $\pm$ 0.72	51 $\pm$ 0.47	59 $\pm$ 1.52
E. Reduction + 0.6 x 0.3 duct up.; damper down.	67 $\pm$ 1.29	64 $\pm$ 1.12	68 $\pm$ 1.23	39 $\pm$ 1.49	48 $\pm$ 1.00
F. Damper + reduction + 0.6 x 0.3 duct up.	68 $\pm$ 0.95	66 $\pm$ 0.68	72 $\pm$ 0.89	41 $\pm$ 0.67	49 $\pm$ 0.92
G. Reduction up.; damper down.; no filter	0 $\pm$ 0.00	0 $\pm$ 0.00	0 $\pm$ 0.00	4 $\pm$ 3.20	4 $\pm$ 3.04

Measurements carried out on each unit that contained a filter (A-F) showed lower pressure losses when the downstream pressure sensor was located a few centimetres from the upstream sensor in comparison with being placed ~65 cm further downstream. Generally the values obtained from sensor positions 2 and 3 (downstream sensors ~65 cm from upstream sensors) better approached the estimated pressure loss stated by the filter manufacturer for the given airflow. Measurements conducted without a filter in place revealed that the filter box itself contributes negligibly to the overall filter pressure loss obtained when the distance between the pressure sensors was ~65 cm.

The pressure drop across a filter varies with the airflow that passes through the filter. Since the length of the filter pockets is over 500 mm, the amount of air that passes through the filter during one second reaches its total value after passing the tips of all pockets. Therefore the pressure drop measured near the frame of the filter is limited to the small fraction of the total airflow that has passed through the filter at that particular position. Moreover, placing the measuring tubes just a few centimetres from each other (positions 4 and 5) on an empty unit (G) showed a slight pressure drop of 4 Pa, with rather high standard deviation. Such observation indicates an uncertainty of the measuring method, especially when the airflow is not smooth, sufficiently slow or when the flow is turbulent. The chance of distorted results is especially high near the walls. Placing a static pressure tip in the middle of the duct could provide a more stable reading. Moreover, measuring the downstream static pressure at an appropriate distance after the pocket filter could be strongly recommended.

Using the perforated probes turned out to be a more stable approach for measuring pressure drop over a filter. The filter pressure drops obtained with the probes while measuring on the



different ventilation units (A-F) varied little. The standard deviations obtained were smaller than for most of the other sensor positions. The pressure-sensing holes in the probes, which were symmetrically distributed across the cross-section of the filter unit, provided an average value of the static pressure at the respective points upstream and downstream of the filter. Small variations in the results can be due to the different airflow patterns, the instrument's inaccuracy, and temporary climatic variations, such as changing wind conditions. Although the probes provide relatively stable readings, their values should not be interpreted as the accurate pressure drop of the tested filter, as its real value was not experimentally determined in a laboratory facility. The number and size of pressure-sensing holes on the probes as well as the position of the probes could influence the results, especially when the flow is turbulent. A higher number of probes may give more exact results. Moreover, probes distributed both vertically and horizontally upstream and downstream of the filter could be beneficial. The prototype presented indicates a possible new measuring approach, but further investigations are required before this method can be reliably applied in common applications.

The pattern of airflow through the filter and thus the observed pressure drop strongly depend on the ductwork and composition of the ventilation unit directly upstream of the filter. When the filter unit was extended upstream with a 500 mm long duct of identical cross-section (units D-F), the results indicated a less turbulent flow through the filter than in A-C modifications of the system. The readings obtained with the probes were consistent with those obtained from the 2-point measurements at the same locations. Moreover, relatively small standard deviations were obtained in comparison with those for units A, B and C.

Although symmetrical reduction in itself does not substantially distort the results (results from sensor positions 2 and 3 for unit B are similar to those for unit E), the reduction directly upstream of the filter may lead to a flow when the central area of the filter face is more exposed to the airstream and less air flows through towards the edges. As a consequence, the measured pressure drop of the filter would be lower close to the walls of the filter housing, where less air reaches from the circular duct upstream of the reduction. A slightly higher pressure drop across the filter was measured when a straight duct with a cross-section identical to that of the filter acted as the system's air intake just upstream of the filter (unit D). Presumably, more air was able to flow near the walls, where the pressure-sensing tubes were located. The flow through the filter box is anticipated in this case to be much less turbulent. The air velocity at the walls of the filter housing would still be lower than in its centre. This results in a slightly higher average pressure drop over the filter's cross-section (obtained with the probes) than that determined with the 2-point technique at positions 2 and 3.

When the damper was placed upstream of the filter (system A), the results of the pressure loss measurements varied greatly with the position of the pressure sensor. When looking in the direction of the airflow, the pressure loss obtained on the left side of the filter box (sensor positions 2 and 4) was significantly lower than the corresponding pressure drop determined on the right side of the housing (sensor positions 3 and 5, respectively). Presumably the half open position of the damper in the direction as indicated in Figure 1 influenced very strongly the pattern of airflow through the filter. The air passed predominantly through the right side of the filter face. We may therefore assume that the highest pressure drop would be measured near the extreme right edge of the filter frame. In a companion experiment, a filter was exposed to a continuous airflow under conditions consistent with those in system A. Visual inspection of the filter after 2 weeks in service revealed that it was most significantly discoloured by particulate pollution on the right side of the filter face. This was observed throughout the filter's entire height (30 cm). The discoloration diminished gradually towards the left and was unnoticeable near the left edge of the filter frame.

Placing the damper downstream of the filter box most likely contributes to the more even distribution of the air as it flows through the surface area of the filter. The pressure losses measured to the left of the box's centre (position 2) on units B, C, D, E and F were very similar to the pressure drops from sensors located more to the right side (position 3). Still, the pressure loss was somewhat higher when measured more to the right. Larger differences would be anticipated if the pressure sensors were placed on the left and right side walls of the filter housing as is usual in practice. The same tendency was observed when the downstream sensors were located near the filter frame (positions 4 and 5). The only exception was system C, where a 90° bend facing upwards was mounted upstream of the filter housing. The bend is expected to lead most of the air to the bottom part of the filter unit and thus more air would pass through the lower areas of the filter bags. Therefore a higher filter pressure drop was measured when the position of the pressure-sensing tubes was at the bottom of the filter housing (position 4) than when they were inserted through the top wall of the box (position 5). This also explains why the values obtained with the 2-point measurements made at positions 2 and 3 (both through the bottom wall), were clearly higher for system C than for any other modifications of the ventilation unit. Most likely the pressure drop of the filter measured in system C would decrease with filter height. Thus the average pressure loss determined by the perforated probes is significantly lower than the pressure loss measured at positions 2 and 3. It approaches the values resulting from more stable systems (D-F) that are assumed to represent better the actual overall pressure drop across the filter.

It should be borne in mind that the experimental setup used in the current study is not representative of many of the real HVAC systems. The duct reductions placed directly up- and downstream of the filters as well as the type and positions of the damper are different from many practical applications. However, the present results suggest that correct determination of a filter's pressure drop can be influenced by the way in which the air passes through the filtration unit. This depends, for example, on the construction of the ventilation system upstream of the filter. Including a pre-filter upstream of a final filter probably helps to measure the pressure drop of the final filter more accurately. In a similar fashion, when the ventilation system includes a 2-step filtration, the first filter is more critical as regards precise establishment of its pressure drop. The first filter in the system may function as a kind of diffuser, ensuring the uniformity of airflow as the air passes to the second filter. Other factors that could affect the value of the filter pressure drop when measured only at a single point upstream and downstream, are the often large spatial differences in the density of the filter material (see Dhaniyala and Liu, 2001) and the uneven distribution of the captured particles across the surface of the filter (Bekö et al., 2007). Computational simulations of the airflow through various ventilation and filtration systems may provide valuable information necessary for sufficiently accurate measurement of the filter pressure drop. They could help in choosing the proper pressure-sensing technique and finding the most appropriate location for its reliable functioning, avoiding the very turbulent zones that are often critical for providing an accurate reading.

The current experiments did not test different positions of the upstream pressure sensors. However, manufacturers of air filter gauges often recommend locating the sensing tips at least 30 cm upstream of the filter, where the zone may be less turbulent than directly before the filter (Dwyer, 2006a). This requirement is rarely met and the low turbulence at such a distance is often not feasible to achieve in practice due to strict space limitations for the heating, ventilation and air-conditioning units. The influence of the location of an upstream pressure sensor on the accuracy of pressure drop measurements should be more closely explored in future.

## 4. Conclusions

The pressure drop of a EU7 fibrous pocket filter was measured in a simple ventilation system with several ductwork modifications upstream of the filter unit. The pressure loss of the filter varied in a wide range, depending on the locations of the up- and downstream static pressure sensors and the profile of airflow through the filter bank. High uncertainty can easily cause incorrect maintenance of the filter bank and consequent financial losses. More reliable results were obtained when the downstream sensors were placed after the tips of the filter pockets instead of beside the filter frame. The present experiments support the fact that uniform flow with low turbulence should be ensured across the filter surface. Such flow can be achieved by avoiding sudden changes in the direction of flow directly upstream of the filter bank. It is beneficial when the ducting right upstream of the filters has the same face area as the filter bank. The use of a 500 mm long straight duct upstream of the filter partly eliminated the negative influence of other ductwork components and improved the accuracy of measurements.

Relatively precise determination of the filter pressure drop could be obtained by measuring the static pressure at a number of points across the face area upstream and downstream of the filter. With this method, the average pressure drop can be obtained from several pressure-sensing points at various locations. For this purpose small diameter tubes with holes facing downstream can be introduced upstream and downstream of the filters, perpendicular to the airflow. The length of the tubes should be consistent with the height or width of the filter bank. Such probes inserted into the filter housing upstream and downstream of the filters and connected to a pressure meter seem to achieve rather stable readings.

## Acknowledgements

This work has been supported by the Danish Technical Research Council (STVF) as part of the research programme of the International Centre for Indoor Environment and Energy established at the Danish Technical University for the period 1998-2007. The author thanks Fang Lei, Geo Clausen and Charlie Weschler for their constructive comments during the preparation of the tests and Niels-Erik Kongste from Camfil Farr Denmark for support with the components of the ventilation unit. Thanks are due to Thomas Pedersen, Peter Simonsen and Erik Christiansen for their help in assembling the facilities and conducting the measurements.

## References

- ASHRAE Handbook. (1988) "Equipment-Air cleaners for particulate contaminants", Chapter 10, 10.1-10.11.
- ASTM F 778-88. (2001) "Standard methods for gas flow resistance testing of filtration media", American Society for Testing Materials.
- Bekö G, Clausen G, Weschler CJ. (2007) "Further studies of oxidation processes on filter surfaces: evidence for oxidation products and the influence of time in service", *Atmospheric Environment*, (in press).
- BS 6277. (1982) "Determination of pressure drop/flow characteristics of hydraulic fluid power filters", British Standards Institution (withdrawn)
- Carrier WH, Cherne RE, Grant WA, Roberts WH. (1959) "Modern air conditioning, heating and ventilation", Pitman Publishing Corp., 3<sup>rd</sup> edition, Chapter 15: Air cleaning, 299-316.

- Dhaniyala S, Liu BYH. (2001) "Theoretical modeling of filtration by nonuniform fibrous filters", *Aerosol Science and Technology*, **34**, 2, 170-178.
- Dwyer Instruments Inc. (2006a) "Air filter gages and switches gages", Product information and product application – free online literature. Accessed 17 October 2006. (<http://www.dwyer-inst.com/htdocs/pressure/AirFilterIntroduction.cfm>).
- Dwyer Instruments Inc. (2006b) "Air velocity measurement", Product information and product application – free online literature. Accessed 17 October 2006. (<http://www.dwyer-inst.com/htdocs/airvelocity/AirVelocityIntroduction.cfm>).
- Fain DE. (1986) "Standards for pressure drop testing of filters as applied to HEPA filters", ASTM special technical publication, ISSN 0066-0558, No. 975, Fluid filtration conference, American Society for Testing and Materials, Vol. 1, 364-379.
- Fisk WJ, Faulkner D, Palonen J, Seppänen O. (2002) "Performance and costs of particle air filtration technologies", *Indoor Air*, **12**, 223-234.
- Matela D. (2006) "Proper filter selection goes a long way", *AFE Facilities Engineering Journal*, **33**, 4, 13-15.
- Weingartner E, Haller P, Burtscher H, Baltensperger U. (1996) "Pressure drop across fiber filters", *Journal of Aerosol Science*, **27**, S1, 639-640.
- Weschler CJ. (1991) "Predictions of benefits and costs derived from improving indoor air quality in telephone switching companies", *Indoor Air*, **1**, 65-78.

## 5. Overall conclusions and recommendations

### 5.1 Conclusions

#### *Chemical processes on filter surfaces*

1. Used ventilation filters can be significant sources of sensory pollution. Oxidative processes occurring on surfaces of used filters appear to be partly responsible for the generation of products that contribute to the degradation of perceived air quality, especially after periods when the ventilation system is not in operation.
2. Used particulate filters removed ozone from the air that passed through them. This ozone removal occurs due to reactions with compounds associated with the captured particles. It varies with the duration of service and nature of the captured particles. Some types of new filters may also remove significant fractions of ozone from the airstream. Reactions of ozone with compounds present on the new filter media following manufacturing may be responsible for ozone removal by new filters and may vary with the type and manufacturer of the filter.
3. The removal of ozone by a filter decreased over time and approached a small and constant value after one to two hours. The constant final removal efficiency may reflect catalytic decomposition of ozone or a balance between reactive organic compounds diffusing to the surface of the filter and reacting at the surface of the filter.
4. When a loaded filter was placed in an environment with no air passing through, it regained some of its ability to remove ozone. This may be partly due to diffusion of oxidizable organics from inside the captured particles to their surface, where they can react with ozone. When the rate of diffusion to the surface is higher than the rate of desorption from the surface into the air, organic compounds will accumulate on the filter surface. Diffusion seems to be enhanced at elevated temperatures. Some of the new fiberglass filters were also found to regain ozone removal capability during periods of no service.
5. A filter that had been previously ventilated with ozone free air for 24 hours initially removed less ozone than a filter that had not been ventilated. Air passing through a loaded filter promoted desorption of reactive organics from the filter surface into the airstream, leaving fewer compounds on the filter surface to subsequently react with ozone. Similarly, the perceived air quality immediately following non-operating periods was significantly deteriorated; however, ventilating the used filter for two hours subsequently improved the air quality downstream of the filter.
6. A filter sample protected from ozone during its service time had subsequently higher ozone removal efficiency than an identical filter not protected from ozone during service. A filter's exposure history may, to some extent, influence the quantity of oxidation products generated when ozone-containing air flows through it.

7. The ratio of downstream to upstream submicron particle concentrations increased when ozone was present in the air passing through loaded particle filters. Ozone initiated reactions on used filter surfaces form semi-volatile oxidation products, which desorb from the filter and partition between the gas phase and the surface of particles in the air downstream of the filter. As a result, particles that had been too small to be counted by the particle counter downstream of the used filter grow in diameter to the point where they become countable.

*Practical solutions to avoid pollution from used ventilation filters*

8. Activated carbon filters downstream of bag filters can reduce the degradation of air quality that occurs with increasing particle loading. A stand-alone fiberglass particle filter containing activated carbon was shown to provide air quality comparable to that obtained with a filter set containing a separate activated carbon filter downstream of a bag filter. It was also observed to remove a large fraction of ozone from the airstream and to have a relatively stable pressure drop over its service period.

*Evaluation of the costs and the economic benefits of filtration*

9. The magnitude of the costs and the monetary benefits of filtration vary with the perspective of the stakeholder and the valuation approach. Regardless, the use of particle filtration leads to economic savings significantly exceeding the direct costs for filtration. However, losses of occupant productivity due to sensory offending pollutants emitted from used ventilation filters can lead to significant economic losses. These losses may substantially exceed the annual benefits of filtration.
10. Major cost reductions attributable to filtration are derived from decreased occupant morbidity and mortality due to exposure to particles. Filtration may also reduce the costs associated with building and HVAC cleaning.

*Measurement of the pressure drop across ventilation filters*

11. The present work confirmed that for exact determination of the filter pressure drop, uniform flow with low turbulence should be ensured across the filter.
12. The measured pressure drop across the filter was dependant on the location of the up- and downstream static pressure sensors. More stable and accurate results were obtained when the downstream sensor was placed near the tips of the filter pockets instead of beside the filter frame.
13. The filter's pressure drop was determined precisely when a manometer measured the difference between the average up- and downstream static pressures which were sensed at several points within the filter's cross-sectional area. For this purpose, new pressure sensing probes were developed.

## 5.2 Recommendations for future research

1. Certain new and slightly used filters were observed to initially remove significant amounts of ozone from the airstream, while other new filters did not remove ozone from the air. Future experiments should evaluate the factors responsible for this observation. The impact of ozone-initiated chemistry on the quality of air downstream of new ventilation filters should be the subject of further investigations.
2. The processes responsible for the regeneration of used and new filters' ozone removal capabilities are not fully understood. Further experiments should be designed to throw new light on the processes responsible for this effect. The number of possible regeneration cycles could be determined as a function of filter material, mass of particles collected on the filter and the nature of those particles.
3. The results of the present study indicate that ozone-initiated oxidation reactions may contribute to the generation of sensory offending pollutants on surfaces of used filters. However, placing an activated carbon filter upstream of a particle filter during its 5-month service time resulted in little improvement of air quality downstream of this filter combination, in comparison with an unprotected filter used in the same manner. These results suggest that chemical transformations other than ozone-initiated reactions may be, to a large extent, responsible for the odor emitted from used filters. More research is necessary before the causes of sensory pollution from used filters can be fully understood.
4. The sensory pollution from different filters and their combinations were examined and the results are presented in this work. However, the generality of the results should be explored over a wider variety of soiling conditions. Variations in sensory pollution from used filters may occur with season, location and source of particles. Moreover, filters soiled with a large fraction of indoor air (in a recirculating air system) may have a different impact on indoor air quality in comparison with used filters soiled with entirely outdoor supply air.
5. The present study indicates excellent performance of filters containing activated carbon over a period of 5 months. However, it is unknown how long such performance would last and how it would vary with soiling conditions. Moreover, the minimum amount of carbon necessary to avoid the emanation of sensory pollution from the activated carbon-containing combination filter, is to be determined.
6. The effect of recirculation on the costs and benefits of filtration has not been studied in detail in the present work. Future analyses of costs and economic benefits associated with filtration in buildings should include ventilation systems working with recirculation air. Additional benefits of filtration driven from reduced soiling of heat exchangers and energy recovery units, were disregarded in the present analyses, but should be included in future studies.
7. Further economic analyses are needed to evaluate the costs and benefits associated with more frequent filter replacement and to evaluate different low-polluting filtration options.

8. Future development of filtration techniques should move towards efficient, low-polluting filtration systems that are easy to maintain, have low life cycle costs and minimal environmental impact.
9. The economic evaluation of filtration presented in this study is dependent on several key input parameters. Some of them may be a source of uncertainty due to the limited information available in the literature. The most relevant ones that warrant further attention are listed below:
  - a. It has not been very well documented at which point in its service-life at given conditions the filter starts to emit sensory offensive pollutants that may impact occupant productivity. Moreover, it has not been previously determined whether the initial negative impact of used filters on productivity changes as particles continue to collect on the filters. Experimental studies are recommended to examine the net effect of sensory pollution from used filters on the productivity of office workers with regard to the filter's time-in-service.
  - b. Epidemiological literature focuses on the health consequences of outdoor particles. The association between indoor generated particles and health should be more closely investigated.
  - c. Data is lacking to accurately estimate how changes in indoor airborne particle concentrations influence building cleaning programs and the associated costs.
10. A prototype of a new pressure sensing probe for the measurement of filter pressure drops was tested as part of the present study. The construction of the probe, the number of probes used and their location within the filter housing may influence the results. Further investigation is required before the method can be reliably applied in common applications.
11. Computational simulations of the airflow pattern in the filtration unit of various ventilation systems may provide helpful information when accurate monitoring of the filter pressure drops is required.

### **5.3 Recommendations for practice**

1. Regardless of the perspective of the stakeholder (building owner, employer who rents the building or employer who owns the building), the use of a common particle filtration strategy (EU7 filters in a single-stage filtration system) may lead to annual economic savings substantially exceeding the direct costs for filtration. However, this requires that the sensory pollution from loaded particle filters is reduced or avoided. Efforts towards the eventual implementation of low-polluting filtration systems are warranted.
2. When a filter is in continuous service, the formation and subsequent off-gassing of sensory offensive pollutants is smaller than when the airflow through the filter is restarted after a break in operation (during nights or weekends). In case of intermittent operation of ventilation systems, the airflow through the filters should be restarted in sufficient time prior to occupancy in order to purge odorous pollutants that have accumulated on the filter surface.



3. More frequent filter replacement would mitigate the degradation of perceived air quality downstream of used filters. Therefore, filters should not be changed based entirely on their final pressure drop but also based on the odors emanating from them.
4. The use of activated carbon filters downstream of particle filters may efficiently remove pollutants emitted from particle filters that have been previously in use for a substantial period.
5. Particle filters that incorporate activated carbon could easily replace commonly used bag filters without modifications to the air handling system. The present work indicates that such combination filters may have comparable particle removal efficiency, may prevent sensory offending pollutants from entering the ventilated space and may remove a fraction of ozone from the supply air. The results signify that such improved air quality would only require modest additional expenses in filter cost and fan energy. However it is necessary to note that further tests should confirm these results before large-scale adoption of this technology may be recommended.
6. To obtain an accurate value when monitoring the filter pressure drop, the flow through the filter should be uniform. Bends or dampers directly upstream of the filter housing should be avoided.
7. When the filter's pressure drop is measured with conventional methods (thru-wall static pressure tips often used in combination with a U-tube manometer), mounting the downstream static pressure sensor at an appropriate distance from the filter frame is recommended. Application of pressure sensing devices, which are less sensitive to air turbulence near the duct walls, would improve the monitoring of filter pressure drops and thus facilitate the correct maintenance of filter banks.

## References

- Afshari, A., Gunnarsen, L. 2000. Review of the sources of fine and ultra fine particles in indoor air. *Environmental Engineering*, September, 45-52.
- Alm, O., Clausen, G. Fanger, P.O. 2000. Exposure-response relationships for emissions from used ventilation filters. In: *Proceedings of Healthy Buildings 2000*, Vol. 2, pp. 245–250.
- Alm, O. 2001. *Ventilation filters and their impact on human comfort, health and productivity*. Doctoral Dissertation, International Centre for Indoor Environment and Energy, Technical University of Denmark, Lyngby.
- ASHRAE Handbook. 1988. *Equipment-Air cleaners for particulate contaminants*. Chapter 10, 10.1-10.11.
- ASHRAE 52.1. 1992. *Gravimetric and Dust Spot Procedures for Testing Air-Cleaning Devices Used in General Ventilation for Removing Particulate Matter*. ANSI/ASHRAE, American National Standard Institute.
- ASHRAE 52.2. 1999. *Method of Testing General Ventilation Air-Cleaning Devices for Removal Efficiency by Particle Size*. ANSI/ASHRAE, American National Standard Institute.
- ASTM F 778-88. 2001. *Standard methods for gas flow resistance testing of filtration media*. American Society for Testing Materials.
- Bánhidi, L., Kajtár, L. 2000. *Komfortelmélet*. Chapter 18: A levegő szűrése szálás szűrőkben. Műegyetemi kiadó, Budapes, p. 321-352 (in Hungarian).
- Bekö, G., Halás, O., Clausen, G., Weschler, C.J. and Toftum J. 2003. Initial studies of oxidation processes on filter surfaces and their impact on perceived air quality. In: *Proceedings of Healthy Buildings 2003*, Singapore, Vol. 3, 156-162.
- Blyussen, P. 1993. Do filters pollute or clean the air?. *Air Infiltration Review*, **14**, 2, March 1993, 9-13.
- Brown, S., Sim, M., Abramson, M., Gray, C. 1994. Concentrations of volatile organic compounds in indoor air -- a review. *Indoor Air*, **4**, 123-134.
- Brunekreef, B, Forsberg, B. 2005. Epidemiological evidence of effects of coarse airborne particles on health. *European Respiratory Journal*, **26**, 309-318.
- BS 6277. 1982. *Determination of pressure drop/flow characteristics of hydraulic fluid power filters*. British Standards Institution (withdrawn)
- Burge, S., Hedge, A., Wilson, S., Bass, J.H., Robertson, A. 1987. Sick building syndrome: A study of 4373 office workers. *Annals of Occupational Hygiene*, **3**, 4A, 493-504.
- Camfil Farr. 2001-2002. Life Cycle Cost software 1.47EU. Camfil Farr.
- Camfil Farr. 2003. Keeping the cost of clean air down. *Airmail. News magazine from Camfil Farr*, **2**, 2-4.
- Carrier, W.H., Cherne, R.E., Grant, W.A., Roberts, W.H. 1959. *Modern air conditioning, heating and ventilation*. Pitman Publishing Corp., 3rd edition, Chapter 15: Air cleaning, 299-316.
- CDC. 2005. *CDC WONDER (1996-1998)*. Atlanta, GA: Center for Disease Control and Prevention. (<http://wonder.cdc.gov>).
- CEN CR1752. 1988. *Ventilation for buildings – Design criteria for the indoor environment*. European Committee for Standardization.
- Cesar, H., Borja-Aburto, V.H., Cicero-Ferandez, P., et al. 2002. Improving air quality in metropolitan Mexico City. An economic valuation. Policy research working paper 2785, The World Bank, ([http://www-wds.worldbank.org/external/default/WDSContentServer/WDSP/IB/2002/03/08/000094946\\_02022604025131/Rendered/PDF/multi0page.pdf](http://www-wds.worldbank.org/external/default/WDSContentServer/WDSP/IB/2002/03/08/000094946_02022604025131/Rendered/PDF/multi0page.pdf)).

- Cifuentes, L., Borja-Aburto, V.H., Gouveia, N., Thurston, G., Davis, D.L., 2001. Assessing the Health Benefits of Urban Air Pollution Reductions Associated with Climate Change Mitigation (2000–2020): Santiago, São Paulo, México City, and New York City. *Environmental Health Perspectives*, **109**, supplement 3, 419-425.
- Clausen, G., Alm, O., Fanger, P.O. 2002a. Sensory source strength of used ventilation filters. *Proceedings of Indoor Air 2002*, Monterey, USA, 1, 344–349.
- Clausen, G., Alm, O., Fanger, P.O. 2002b. The impact of air pollution from used ventilation filters on human comfort and health. In: *Proceedings of the 9th International Conference on Indoor Air Quality and Climate Indoor Air 2002*, Monterey, CA, USA, Vol. 1, 338–343.
- Clausen, G. 2004. Ventilation filters and indoor air quality: a review of research from the International Centre for Indoor Environment and Energy. *Indoor Air*, **14**, **S7**, 202-207.
- Clayton, C.A., Perrit, R.L., Pellizzari, E.D., Thomas, K.W., Whitmore, R.W., Wallace, L.A., Özkaynak, H. and Spengler, J.D. 1993. Particle total exposure assessment methodology (PTEAM) study: distributions of aerosol and elemental concentrations in personal, indoor and outdoor air samples in a southern California community. *Journal of Exposure Analysis and Environmental Epidemiology*, **3**, 227-250.
- Cohen, A.J., Anderson, H.R., Ostro, B., Pandey, K.D., Krzyzanowski, M., Künzli, N., Gutschmidt, K., Pope, C.A. III, Romieu, I., Samet, J.M. and Smith, K.R. 2004. Urban air pollution. In: *Comparative quantification of health risks. Global and Regional Burden of Disease Attributable to Selected Major Risk Factors*, edited by Ezzati, M., Lopez, A.D., Rodgers, A., Murray, C.J.L., WHO, Vol. 1, 1354-1433, (<http://www.who.int/publications/cra/chapters/volume2/1353-1434.pdf>).
- Committee on Health Effects of Indoor Allergens. 1993. *Indoor Allergens: Assessing and Controlling Adverse Health Effects* edited by Pope, A.M., Patterson, R., and Burge, H., Washington, D.C., National Academy Press.
- Couch, R.B. 1981. Viruses and indoor air pollution. *Bulletin of the New York Academy of Medicine*, **57**, 907-921.
- Dhaniyala, S., Liu, B.Y.H. 2001. Theoretical modeling of filtration by nonuniform fibrous filters. *Aerosol Science and Technology*, **34**, 2, 170-178.
- Djukanovic, R., Wargocki, P., Fanger, P.O. 2002. Cost-benefit analysis of improved air quality in an office building. *Proceedings of Indoor Air 2002*, Monterey, Vol. 1, 808-813.
- Dockery, D.W., Pope, C.A.III, Xu, X., Spengler, J.D., Ware, J.H., Fay, M.E., Ferris, B.G. and Speizer, F.E. 1993. An association between air pollution and mortality in six US cities. *The New England Journal of Medicine*, **329** (24), 1753-59.
- Dominici, F., Peng, R.D., Bell, M.L., Pham, L., McDermott, A., Zeger, S.L., Samet, J.M. 2006. Fine particulate air pollution and hospital admission for cardiovascular and respiratory diseases. *Journal of American Medical Association*, **295**, 10, 1127-1134.
- Dwyer Instruments Inc. 2006a. *Air filter gages and switches gages*. Product information and product application – free online literature. Accessed 17 October 2006. (<http://www.dwyer-inst.com/htdocs/pressure/AirFilterIntroduction.cfm>).
- Dwyer Instruments Inc. 2006b. *Air velocity measurement*. Product information and product application – free online literature. Accessed 17 October 2006. (<http://www.dwyer-inst.com/htdocs/airvelocity/AirVelocityIntroduction.cfm>)
- Elixmann, J.H., Jorde, W., Linskens, H.F. 1987a. Filters of an air-conditioning installation as disseminators of fungal spores. *Advances in Aerobiology*, 51, 283-286.
- Elixmann, J.H., Jorde, W., Linskens, H.F. 1987b. Changes of fungal growth under different climatic conditions in air conditioning filters. In: *Abstracts of XIV international botanical congress*, Berlin, p.149.

- EN 1822. 1998. *High efficiency air filters (HEPA and ULPA). Part 1: Classification, performance testing, marking; Part 2: Aerosol Production, Measuring Equipment, Particle Counting Statistics; Part 3: Testing Flat Sheet Filter Media*. European Committee for Standardization.
- EN 1822. 2000. *High Efficiency Particulate Air Filters (HEPA and ULPA). Part 4: Determining Leakage of Filter Element (Scan Method); Part 5: Determining the Efficiency of Filter Element*. European Committee for Standardization.
- EN 779. 2002. *Particulate air filters for general ventilation. Determination of the filtration performance*. European Committee for Standardization.
- EN 13779. 2004. *Ventilation for non-residential buildings. Performance requirements for ventilation and room-conditioning systems*. European Committee for Standardization.
- EUROVENT 4/9. 1996. *Method of testing air filters used in general ventilation for determination of fractional efficiency*. EUROVENT-CECOMAF, European Committee of Air Handling and Refrigeration Equipment Manufacturers.
- EUROVENT 4/10. 2005. *In situ determination of fractional efficiency of general ventilation filters*. EUROVENT-CECOMAF, European Committee of Air Handling and Refrigeration Equipment Manufacturers.
- EUROVENT. 1999. *Recommendation concerning calculation of life cycle costs for air filters*. European committee of air handling, air conditioning and refrigeration equipment manufacturers; January, 1999.
- Fain, D.E. 1986. Standards for pressure drop testing of filters as applied to HEPA filters. *ASTM special technical publication*, ISSN 0066-0558, No. 975, *Fluid filtration conference*, American Society for Testing and Materials, Vol. 1, 364-379.
- Fanger, P.O., Lauridsen, J., Bluyssen, P. and Clausen, G. 1988. Air pollution sources in offices and assembly halls, quantified by the olf unit. *Energy and Buildings*, **12**, 7-19.
- FISIAQ. 1995. *Classification of indoor climate, construction and finishing materials*. Finnish society of indoor air quality and climate, Espoo, Finland.
- Fisk, W.J., Rosenfeld, A.H. 1997. Estimates of improved productivity and health from better indoor environments. *Indoor Air*, **7**, 158-172.
- Fisk, W. J., Faulkner, D., Palonen, J., Seppänen, O. 2002. Performance and costs of particle air filtration technologies. *Indoor Air*, **12**, 223-234.
- Fitzner, K. 2000. Control of pollutants in air handling systems. In: *Proceedings of Healthy Buildings 2000*. Espoo, Finland, Vol. 2, 21-33.
- Franke, D.L., Cole, E.C., Leese, K.E., Foarde, K.K., Berry, M.A. 1997. Cleaning for improved indoor air quality: an initial assessment of effectiveness. *Indoor Air*, **7**, 41-54.
- Fransson, J.I., Ruud, S.H., Rosell, L. 1995. Rena ventilationskanaler (Clean air ducts). Swedish National Testing and Research Institute, SP, Report 1995:38.
- Gholami, S., Pejtersen, J., Clausen, G. and Fanger, P.O. 1997. Sensory pollution load caused by HVAC components. In: *Proceedings of IAQ '97 Healthy Buildings*, Washington DC, USA, Vol. 1, 545-550.
- Gong, H.Jr., Sioutas, C., Linn, W.S. 2003. Controlled Exposures of Healthy and Asthmatic Volunteers to Concentrated Ambient Particles in Metropolitan Los Angeles. Research Report 118. Health Effects Institute, Boston MA (<http://pubs.healtheffects.org/view.php?id=101>).
- Hangström, K., Holmber, R., Lehtimäki, M., Rilio, J., Siitonen, E. 1996. *Hinkkassuodatuksen perusteet ja optimaalinen valinta*. INVENT/Suodatin-projekti, Vaihe 1, Raportti 48, MET, 1-54. (in Finnish).
- Hanley, J.T., Ensor, D.S., Smith, D.D., Sparks, L.E. 1994. Fractional aerosol filtration efficiency of in-duct ventilation air cleaners. *Indoor Air*, **4**, 169-178.

- Hänninen, O.O., Palonen, J., Tuomisto, J.T., Yli-Tuomi, T., Seppänen, O., Jantunen, M.J. 2005. Reduction potential of urban PM<sub>2.5</sub> mortality risk using modern ventilation systems in buildings. *Indoor Air*, **15**, 246-256.
- Hinds, W.C. 1999. *Aerosol technology*. John Wiley & Sons, New York.
- Hodgson, A. T., Levin, H. 2003. *Volatile Organic Compounds in Indoor Air: A Review of Concentrations Measured in North America Since 1990*; LBNL-51715; Lawrence Berkeley National Laboratory: Berkeley, CA, 31 pp.
- Holgate, S.T. 2003. Health Effects of Acute Exposure to Air Pollution. Research Report 112. Health Effects Institute, Boston MA (<http://pubs.healtheffects.org/view.php?id=104>).
- Hubbell, B.J., Hallberg, A., McCubbin, D.R., Post, E. 2005. Health-related benefits of attaining the 8-hr ozone standard. *Environmental Health Perspectives*, **113** (1), 73-82.
- Hujanen, M., Seppänen, O., Pasanen, P. 1991. Odor emission from the used filters of air-handling units. *Proceedings of Healthy Buildings 1991*, Washington DC, 329–333.
- Hyttinen, M., Pasanen, P., Kalliokoski, P. 2001. Adsorption and desorption of selected VOCs in dust collected on air filters. *Atmospheric Environment*, **35**, 5709-5716.
- Hyttinen, M., Pasanen, P., Kalliokoski, P. 2002. VOC emissions from dusty filters. *Proceedings of the 9<sup>th</sup> International Conference on Indoor Air Quality and Climate - Indoor Air 2002*, 368-373.
- Hyttinen, M., Pasanen, P., Salo, J., Björkroth, M., Vartianen, M. and Kalliokoski, P. 2003. Reactions of ozone on ventilation filters. *Indoor and Built Environment* 2003, 12, 151-158.
- Hyttinen, M., Pasanen, P., Kalliokoski, P. 2006. Removal of ozone on clean, dusty and sooty supply air filters. *Atmospheric Environment*, **40**, 315-325.
- Hyttinen, M., Pasanen, P., Björkroth, M., Kalliokoski, P. 2007a. Odors and volatile organic compounds released from the ventilation filters. *Atmospheric Environment*, **41**, **19**, 4029-4039.
- Hyttinen, M., Laitinen, T., Pasanen, P., Kalliokoski, P. 2007b. Ozone Removal, ultra fine particles, and VOC levels on sooty supply air filters in the presence of alphapinene. *Proceedings of Clima 2007*, Helsinki, Finland.
- Jamriska, M., Morawska, L., Ensor, D.S. 2003. Control strategies for sub-micrometer particles indoors: model study of air filtration and ventilation. *Indoor Air*, **13**, 96-105.
- Jerrett, M., Burnett, R.T., Renjun, M., Pope, A.C., Krewski, D., Newbold, K.B., Thurston, G., Yuanli, S., Finkelstein, N., Calle, E.E., Thun, M.J. 2005. Spatial analysis of air pollution and mortality in Los Angeles. *Epidemiology*, **16**, 6, 727-736.
- Kemp, S.J., Kuehn, T.H., Pui, D.Y.H., Vesley, D., Streifel, A.J. 1995a. Filter collection efficiency and growth of microorganisms on filters loaded with outdoor air. *ASHRAE Transactions*, 101, 228-238.
- Kemp, S.J., Kuehn, T.H., Pui, D.Y.H., Vesley, D., Streifel, A.J. 1995b. Growth of microorganisms on HVAC filters under controlled temperature and humidity conditions. *ASHRAE Transactions*, 101, 305-316.
- Kildesø, J., Tornvig, L., Skov, P., Schneider, T. 1998. An intervention study of the effect of improved cleaning methods on the concentration and composition of dust. *Indoor Air*, **8**, 12-22.
- Kildesø, J., Schneider, T. 2001. Prevention with cleaning. In: *Indoor air quality handbook*, edited by Spangler, J.D., McCarthy, J.F., Samet, J.M., McGraw-Hill, New York, 64.1-64.18.
- Klenø Nøjgaard J.G., Christensen K.B., Wolkoff P., 2005. The effect on human eye blink frequency of exposure to limonene oxidation products and methacrolein. *Toxicology Letters*, **156**, 241-251.

- Laskin, D.L., Morio, L., Hooper, K., Li, T.-H., Buckley, B., Turpin, B. 2003. Peroxides and Macrophages in the Toxicity of Fine Particulate Matter in Rats. Research Report 117. Health Effects Institute, Boston MA (<http://pubs.healtheffects.org/view.php?id=102>)
- Lee, P., Davidson, J. 1999. Evaluation of activated carbon filters for removal of ozone at the PPB level. *American Industrial Hygiene Association Journal*, **60**, (5), 589-600.
- Lee, K.W., Liu, B.Y.H. 1980. On the minimum efficiency and the most penetrating particle size for fibrous filters. *Journal of the Air Pollution Control Association*, **30**(4), 377-381.
- Long, C.M., Suh, H.H., Kobzik, L., Catalano, P.J., Ning, Y.Y., Koutrakis, P. 2001. A pilot investigation of the relative toxicity of indoor and outdoor fine particles: In vitro effects of endotoxin and other particulate properties. *Environmental Health Perspectives*, **109**, 10, 1019-1026.
- Martikainen, P., Asikainen, A., Nevalainen, A., Jantunen, M., Pasanen, P., Kalliokoski, P. 1990. Microbial growth on ventilation filter materials. In: *Proceedings of Indoor Air 1990*, Ottawa, Canada, Vol.3, 203-206.
- Matela, D. 2006. Proper filter selection goes a long way. *AFE Facilities Engineering Journal*, **33**, 4, 13-15.
- Maus, R., Goppelsröder, A., Umhauer, H. 1996. Viability of microorganisms in fibrous air filters. In: *Proceedings of Indoor Air 1996*, Nagoya, Japan, Vol.3, 137-142.
- McDonald, B., Ouyang, M. 2001. Air cleaning – particles. In: *Indoor Air Quality Handbook*, edited by Spengler, J.D., Samet, J.M., McCarthy, J.F., McGraw-Hill, New York, 2001, 9.1-9.28.
- Mendell, M.J., Smith, A.H. 1990. Consistent pattern of elevated symptoms in air-conditioned office buildings: a reanalysis of epidemiologic studies. *American Journal of Public Health*, **80**, 1193–1199.
- Mendell, M.J., Fisk, W.J., Petersen, M., Dong, M.X., Hines, C.J., Faulkner, D., Deddens, J.A., Ruder, A.M., Sullivan, D., Boeniger, M.F. 1999. Enhanced particle filtration in non-problem office environment: summary finding from a double-blind crossover intervention study. *Proceedings of Indoor Air 1999*, Edinburgh, Vol. 4, 974-975.
- Metts, T.A., Batterman, S.A., Fernandes, G.I., Kalliokoski, P. 2005. Ozone removal by diesel particulate matter. *Atmospheric Environment*, **39**, 3343–3354.
- Metts, T. A., and Batterman, S. A. 2006. Effect of VOC loading on the ozone removal efficiency of activated carbon filters. *Chemosphere*, **62**, 34-44.
- Milton, D.K. 1996. Bacterial endotoxins: a review of health effects and potential impact in the indoor environment. In: Gammage R.B. and Bervens B.A (eds): *Indoor air and human health*, 2<sup>nd</sup> edition, CRC Press, Boca Raton, 179-195.
- Morrison, G.C., Nazaroff, W. W., Cano-Ruiz, J. A., Hodgson, A. T., Modera, M. P. 1998. Indoor air quality impacts of ventilation ducts: ozone removal and emissions of volatile organic compounds. *Journal of the Air and Waste Management Association*, **48**, 941-952.
- Mølhav, L. and Thorsen, M. 1989. Konsekvenserne af øget recirculation i ventilationsanlæg. *Institut for Miljø- og Arbejdsmedicin, Århus Universitet*, (unpublished document, in Danish).
- Mølhav, L., Thorsen, M. 1991. A model for investigations of ventilation systems as sources for volatile organic compounds in indoor climate. *Atmospheric Environment*, **25a**, 241-249.
- Möriz, M., Weist, K., Schleibinger, H. 1999. Accumulation of endotoxins on air filters in heating, ventilation and air conditioning (HVAC) systems. In: *Proceedings of Indoor Air 1999*, Edinburgh, Scotland, Vol.2
- Mysen M., Clausen G., Bekö G., Halas, O. 2003. The influence of typical ways of operating an air-handling unit on the sensory pollution load from used bag filters. In: *Proceedings of Healthy Buildings 2003*, Singapore, Vol. 3, 267-272.

- Mysen, M., Magnussen, K., Nilsen, S.K., Schild, P.G. 2006. Emissions from different types of used ventilation bag filters and their impact on perceived air quality. In: *Proceedings of Healthy Buildings 2006*, Lisbon, Portugal, Vol.4, 471-474.
- Nazaroff, W.W, Weschler, C.J., 2004. Cleaning products and air fresheners: exposure to primary and secondary air pollutants. *Atmospheric Environment*, **38**, 2841-2865.
- Neumeister, H.G., Möritz, M., Schleibinger, H., Martiny, H. 1996. Investigation of allergic potential induced by fungi on air filters of HVAC systems. In: *Proceedings of Indoor Air 1996*, Nagoya, Japan, Vol.3, 125-130.
- Owen, M.K., Ensor, D.S., Sparks, L.E. 1992. Airborne particle sizes and sources found in indoor air. *Atmospheric Environment*, **26A**, 12, 2149-2162.
- Pasanen, P. et al. 1990. Ilmanvaihtolaitteiden suodattimien aiheuttamat haju- ja mikrobihaitat toimistotiloissa. (Odor and microbial problems due to supply air filters). Report series in Environmental Sciences, 6/1990, University of Kuopio, Finland, 72pages (in Finnish)
- Pasanen, P., Teijonsalo, J., Seppänen, O., Ruuskanen, J., Kalliokoski, P., 1994. Increase in perceived odor emissions with loading of ventilation filters. *Indoor Air*, **4**, 106-113.
- Pasanen, P. 1998. *Emissions from filters and hygiene of air ducts in the ventilation systems of office buildings*. Doctoral dissertation, Kuopio University Publications C. Natural and Environmental Sciences 80, 1-77.
- Pavlogeorgatos, G. 2003. Environmental parameters in museums. *Building and Environment*, **38**, 1457-1462.
- Pejtersen, J., Bluysen, P., Kondo, H., Clausen, G. and Fanger, P.O. 1989. Air pollution sources in ventilation systems. In: *Proceedings of CLIMA 2000*, Sarajevo, August 1989, Vol. 3, 139-144.
- Pejtersen, J., Clausen, G., Sørensen, J., Quistgaard, D., Iwashita, G., Zhang, Y., Onishi, T. and Fanger, P.O. 1991. Air pollution sources in kindergartens. In: *Proceedings of IAQ '91 Healthy Buildings*, Washington DC, USA, 221-224.
- Pejtersen, J. 1996. Sensory pollution and microbial contamination of ventilation filters. *Indoor Air*, **6**, 239-248.
- Pollmann, J., Ortega, J. Helmig, D., 2005. Analysis of atmospheric sesquiterpenes: sampling losses and mitigation of ozone interferences. *Environmental Science and Technology*, **39**, 9620-9629.
- Pope, C.A.III, Thun, M.J., Namboodiri, M.M., Dockery, D.W., Evans, J., Speizer, F.E. and Heath, C. 1995. Particulate air pollution as a predictor of mortality in a prospective study of US adults. *American Journal of Respiratory and Critical Care Medicine*, **151**, 669-674.
- Pope, C.A.III, Burnett, R.T., Thun, M.J., Calle, E.E., Krewski, D., Ito, K., Thurston, G.D. 2002. Lung cancer, cardiopulmonary mortality and long-term exposure to fine particulate air pollution. *Journal of American Medical Association*, **287**, 9, 1132-1141.
- Riley, W.J., McKone, T.E., Lai, A.K., Nazaroff, W.W. 2002. Indoor Particulate Matter of Outdoor Origin: Importance of Size-Dependent Removal Mechanisms. *Environmental Science and Technology*, Vol. **36**, 200-207.
- Rohr, A.C., Weschler, C.J., Koutrakis, P., Spengler, J.D. 2003. Generation and quantification of ultrafine particles through terpene/ozone reactions in a chamber setting. *Aerosol Science and Technology*, **37**(1), 65-78.
- Rudnick, S.N. 2004. Optimizing the design of room air filters for the removal of submicrometer particles. *Aerosol Science and Technology*, **38**, 861-869.
- Sandström, T., Nowak, D., Van Bree, L. 2005. Health effects of coarse particles in ambient air: messages for research and decision-making. *European Respiratory Journal*, **26**, 187-188.
- Schneider, T., Nilsen, S.K., Dahl, I. 1994. Cleaning methods, their effectiveness and airborne dust generation. *Building and environment*, **29**(3), 369-372

- Schneider, T., Sundell, L., Bischof, W., Bohgard, M., Cherrie, J.W., Clausen P.A., Dreborg S., Kildesø, J., Kjærgaard, S.K., Løvik, M., Pasanen, P., Skyberg, K. 2003. 'EUROPART', Airborne particles in the indoor environment, an European interdisciplinary review of scientific evidence on associations between exposure to particles in buildings and health effects". *Indoor Air*, **13**, 38-48.
- Shair, F.H. 1981. Relating indoor pollutant concentrations of ozone and sulfur dioxide to those outside: Economic reduction of indoor ozone through selective filtration of the make-up air. *ASHRAE Transactions*, 87(I), 116-139.
- Shields, H.C., Weschler, C.J., Naik, D.V. 1999. Ozone removal by charcoal filters after continuous extensive use (5 to 8 years). In: *Proceedings of Indoor air 1999*, Construction communications Ltd., London, Vol.4, 49-54.
- Skov, P., Valbjørn, O. 1987. The sick building syndrome in the office environment: The Danish townhall study. *Environment International*, **13**, 339-349.
- Skulberg, K.R., Skyberg, K., Kruse, K., Eduard, W., Djupesland, P., Levy, F., Kjuus, H. 2004. The effect of cleaning on dust and the health of office workers: An intervention study. *Epidemiology*, **15**, 1, 71-78.
- Strøm-Tejsen, P., Clausen, G. and Toftum, J. (2003) "Sensory pollution load from a used ventilation filter at different airflow rates", In: *Proceedings of Healthy Buildings 2003*, Singapore, Vol. 3, 257-261.
- Sundell, J. 1999. (Principal author) *Indoor Environment and Health*. Stockholm, Sweden: National Institute of Public Health.
- Sundell, J. 2004. On the history of indoor air quality and health. *Indoor Air*, **14**, S7, 51-58.
- Tamás, Gy. (2005) *Ozone initiated reactions and human comfort in indoor environments*, Doctoral Dissertation, International Centre for Indoor Environment and Energy, Technical University of Denmark, Lyngby.
- Tamás, G., Weschler, C.J., Toftum, J., Fanger, P.O. 2006. Influence of ozone-limonene reactions on perceived air quality. *Indoor Air*, **16**, 168-178.
- Teijonsalo, J., Pasanen, P., Seppänen, O. 1993. Filters of air supply units as sources of contaminants. *Proceedings of the 6th International Conference on Indoor Air Quality and Climate - Indoor Air '93*, Vol. 6, 533-538.
- Thatcher, T., Layton, D. 1995. Deposition, resuspension, and penetration of particles within a residence. *Atmospheric Environment*, **29**, 1487-1497.
- Thorstensen, E., Hansen, C., Pejtersen, J., Clausen, G. and Fanger, P.O. 1990. Air pollution sources and indoor air quality in schools. In: *Proceedings of the 5th International Conference on Indoor Air Quality and Climate Indoor Air '90*, Toronto, Vol. 1, 531-536.
- Tucker, G. 2001. Volatile organic compounds. In: *Indoor Air Quality Handbook*, edited by Spengler, J.D., Samet, J.M., McCarthy, J.F., McGraw-Hill, New York, 2001, 31.1-31.17.
- Underhill, D. 2001. Removal of gases and vapors. In: *Indoor Air Quality Handbook*, edited by Spengler, J.D., Samet, J.M., McCarthy, J.F., McGraw-Hill, New York, 10.1-10.19.
- US Census Bureau. 2005. Accessed via CDC WONDER on-line database, Center for Disease Control and Prevention. (<http://wonder.cdc.gov>).
- US Department of Labor. 2005. Bureau of Labor Statistics. National compensation survey: Occupational wages in 2005, (<http://www.bls.gov/ncs/home.htm>).
- US EPA. 1992. *Respiratory health effects of passive smoking: Lung cancer and other disorders*. United States Environmental Protection Agency, Washington DC, (EPA/600/6-90/006F).
- US EPA. 1995. *The inside story: A guide to indoor air quality*. United States Environmental Protection Agency, EPA Document No. 402-K-93-007 ([www.epa.gov/iaq/pubs/insidest.html](http://www.epa.gov/iaq/pubs/insidest.html)).



- US EPA. 1997a. *An Office Building Occupant's Guide to Indoor Air Quality*. United States Environmental Protection Agency, Office of Research and Development, Washington DC, (EPA/402/K-97/003aF).
- US EPA. 1997b. *National Ambient Air Quality Standards for Particulate Matter*. United States Environmental Protection Agency, (<http://www.epa.gov/ttnamti1/pmcfr.html>). In: 40 CFR Part 50, AD-FRL-5725-2).
- US EPA. 1999. *The benefits and costs of the clean air act. Report to Congress*. United States Environmental Protection Agency.
- Wainman, T., Zhang, J., Weschler, C.J., Liou, P.J. 2000. Ozone and limonene in indoor air: a source of submicron particle exposure. *Environmental Health Perspectives*, **108**, 1139-1145.
- Wallace, L. 1996. Indoor particles: a review. *Journal of the Air & Waste Management Association*, **46**, 98-126.
- Wallace, L. 2000. Correlations of Personal Exposure to Particles with Outdoor Air Measurements: A Review of Recent Studies. *Aerosol Science & Technology*, **32** (1), 15-25.
- Wargocki, P., Wyon, D.P., Baik, Y.K., Clausen, G. and Fanger, P.O. 1999. Perceived air quality, Sick Building Syndrome (SBS) symptoms and productivity in an office with two different pollution loads. *Indoor Air*, **9**, 165-179.
- Wargocki, P., Wyon, D.P., Sundell, J., Clausen, G. and Fanger, P.O. 2000a. The effects of outdoor air supply rate in an office on perceived air quality, Sick Building Syndrome (SBS) symptoms and productivity. *Indoor Air*, **10**, 222-236.
- Wargocki, P., Wyon, D.P., Fanger, P.O. 2000b. Pollution source control and ventilation improve health, comfort and productivity. *Proceedings of the Third International Conference on Cold Climate Heating, Ventilating and Air Conditioning - Cold Climate HVAC 2000*, Sapporo, 445-450.
- Wargocki, P., Wyon, D.P., Fanger, P.O. 2000c. Productivity is affected by the air quality in offices. *Proceedings of Healthy Buildings 2000*, Espoo, Vol. 1, 635-640.
- Wargocki, P., Wyon, D.P. and Fanger, P.O. 2003. Call-centre operator performance with new and used filters at two different outdoor air supply rates. In: *Proceedings of Healthy Buildings 2003*, Singapore, Vol. 3, 213-218.
- Wargocki, P., Wyon, D.P., Fanger, P.O. 2004a. The performance and subjective responses of call-centre operators with new and used supply air filters at two outdoor air supply rates. *Indoor Air*, **14**, S8, 7-16.
- Wargocki, P. 2004b. Sensory pollution sources in buildings. *Indoor Air*, **14**, S7, 82-91.
- Weather Underground. 2007. *Weather history for Copenhagen, Denmark*. Accessed via Weather Underground ([www.wunderground.com](http://www.wunderground.com)).
- Weingartner, E., Haller, P., Burtscher, H., Baltensperger, U. 1996. Pressure drop across fiber filters. *Journal of Aerosol Science*, **27**, S1, 639-640.
- Weschler, C.J. 1991. Predictions of benefits and costs derived from improving indoor air quality in telephone switching companies. *Indoor Air*, **1**, 65-78.
- Weschler, C.J., Shields, H.C., Naik, D.V. 1993. An evaluation of activated carbon filters for the control of ozone, sulfur dioxide and selected volatile organic compounds. In: *Proceedings of Indoor Air Quality 1992, Environment for people*, ASHRAE, 233-241.
- Weschler, C.J., Shields, H.C., Naik, D.V. 1994. Ozone-removal efficiencies of activated carbon filter after more than three years of continuous service. *ASHRAE Transactions 100*, Part 2, 1121-1129.
- Weschler, C.J., Shields, H., Shah, B. 1996. Understanding and reducing the indoor concentration of submicron particles at a commercial building in Southern California. *Journal of the Air & Waste Management Association*, **46**, 291-299.

- Weschler, C.J., Shields, H.C. 1997. Potential reactions among indoor pollutants. *Atmospheric Environment*, **31**, 3487–3495.
- Weschler, C.J., Shields, H.C. 1999. Indoor ozone/terpene reactions as a source of indoor particles. *Atmospheric Environment*, **33**, 2301-2312.
- Weschler, C.J. 2000. Ozone in indoor environments: concentration and chemistry. *Indoor Air*, **10**, 269–288.
- Weschler, C. J., 2003a. Indoor chemistry as a source of particles. In *Indoor Environment: Airborne Particles and Settled Dust*, edited by Morawska, L. and Salthammer, T. pp. 171-194, Wiley-VCH, Weinheim.
- Weschler, C.J. 2003b. Indoor/outdoor connections exemplified by processes that depend on an organic compound's saturation vapor pressure. *Atmospheric Environment*, **37**, 5455-5465.
- Weschler, C.J. 2004. Chemical reactions among indoor pollutants: what we've learned in the new millennium. *Indoor Air*, **14**, S7, 184-194.
- Weschler, C. J. 2006. Ozone's impact on public health: contributions from indoor exposures to ozone and products of ozone-initiated chemistry. *Environmental Health Perspectives*, **114**, 1489-96.
- WHO. 1989. *Indoor air quality: Organic pollutants*. EURO Reports and studies 111, World Health Organization, Copenhagen, Regional Office for Europe.
- WHO. 2000. *The Right to Healthy Indoor Air*. Report on a WHO Meeting, May 15-17, Bilthoven, The Netherlands, World Health Organization, Copenhagen, Regional Office for Europe, (EUR/00/5020494), ([www.euro.who.int/document/e69828.pdf](http://www.euro.who.int/document/e69828.pdf)).
- WHO. 2002. *Reducing risks, promoting healthy life*. The world health report 2002, World Health Organisation.
- WHO. 2005. *WHO air quality guidelines global update 2005*. Report on a working group meeting, October 18-20, Bonn, Germany, World Health Organization.
- Wolkoff, P., Nielsen, G.D. 2001. Organic compounds in indoor air – their relevance for perceived indoor air quality?. *Atmospheric Environment*, **35**, 4407-4417.
- Won, D., Corsi, R.L. and Rynes, M. 2000. New indoor carpet as an adsorptive reservoir for volatile organic compounds, *Environmental Science and Technology*, **34**, 4193–4198.
- Won, D., Corsi, R.L. and Rynes, M. 2001. Sorptive interactions between VOCs and indoor materials. *Indoor Air*, **11**, 246–256.
- Wyon, D.P., Tham, K.W., Croxford, B., Young, A., Oreszczyn, T., 2000. The effects on health and self-estimated productivity of two experimental interventions which reduced airborne dust levels in office premises. *Proceedings of Healthy Buildings 2000*, Espoo, Vol. 1, 641-646.
- Zhao, P., Siegel, J.A., Corsi, R.L. 2005. Ozone removal by residential HVAC filters. In: *Proceedings of 10th International Conference on Indoor Air Quality and Climate*, Indoor Air 2005, Beijing, China, 2366-2370.
- Zhao, P. 2006. *Ozone interactions with HVAC filters*. Doctoral dissertation, University of Texas at Austin, December 2006.
- Zhao, P, Siegel, JA, Corsi, RL. 2007. Ozone removal by HVAC filters. *Atmospheric environment*, **41**, 15, 3151-3160.