

Technical University of Denmark



Possible Future SOFC - ST Based Power Plants

Rokni, Masoud; Scappin, Fabio

Published in:
Proceedings of SIMS 50

Publication date:
2009

Document Version
Publisher's PDF, also known as Version of record

[Link back to DTU Orbit](#)

Citation (APA):
Rokni, M., & Scappin, F. (2009). Possible Future SOFC - ST Based Power Plants. In Proceedings of SIMS 50: Modeling of Energy Technology (pp. 181-188). Copenhagen.

DTU Library

Technical Information Center of Denmark

General rights

Copyright and moral rights for the publications made accessible in the public portal are retained by the authors and/or other copyright owners and it is a condition of accessing publications that users recognise and abide by the legal requirements associated with these rights.

- Users may download and print one copy of any publication from the public portal for the purpose of private study or research.
- You may not further distribute the material or use it for any profit-making activity or commercial gain
- You may freely distribute the URL identifying the publication in the public portal

If you believe that this document breaches copyright please contact us providing details, and we will remove access to the work immediately and investigate your claim.

POSSIBLE FUTURE SOFC – ST BASED POWER PLANTS

Masoud Rokni¹ and Fabio Scappin
Technical University of Denmark,
Dept. Mechanical Engineering,
Thermal Energy Systems, 2800 Lyngby, Denmark

ABSTRACT

Hybrid systems consisting of Solid Oxide Fuel Cell (SOFC) on the top of a Steam Turbine (ST) are investigated. The plants are fired by natural gas. A desulfurization reactor removes the sulfur content in the NG while a pre-reformer breaks down the heavier hydrocarbons. The pre-treated fuel enters then into the anode side of the SOFC. The gases from the SOFC stacks enter into a burner to burn the rest of the fuel. The off-gases now enter into a heat recovery steam generator to produce steam for a Rankine cycle. Different system setups are considered. Cyclic efficiencies up to 67% are achieved which is considerably more than the conventional combined cycles (CC). Both ASR (Adiabatic Steam Reformer) and CPO (Catalytic Partial Oxidation) fuel reformer reactors are considered in this study.

Keywords: SOFC, Rankine cycle, steam plant, steam cycle, hybrid system

INTRODUCTION

The Solid Oxide Fuel Cell (SOFC) is an electro-chemical reactor currently under development by several companies for power-heat generation application. Depending on the type of the electrolyte they are operating at temperature levels of more than about 750°C up to 1000°C. The lower temperature alternative is now being developed for market entry during the next decade. Due to material complication on the BoP (Balance of Plant) components some companies are trying to find new materials for the SOFC cells to decrease the operating temperature of the SOFC stacks. Temperatures of about 650°C are also mentioned.

The biggest advantage of the SOFC in comparison with other types of fuel cells may be in its flexibility in using different types of fuels. However, in planar SOFCs one needs to pre-process most kind of fuels in order to break down the heavier hydro-carbons which may otherwise poison the solid oxide fuel cells. The sulphur content in the fuels must firstly be removed and then pre-reformed before entering the anode side of the SOFC. Such pre-processing can be done in two different catalytic reactors operating at

different temperature levels indicated by reactor manufacturers.

SOFC – based power plants have been studied for a while and some companies, such as Wärtsilä, are trying to realize such a system for CHP (Combined Heat and Power) applications; see e.g. [1]. The SOFC is also combined with CC (Combined Cycles) in the literature to achieve ultra high electrical efficiencies, see e.g. [2–3]. Due to the current operating temperature of the SOFC stacks (more than about 750°C), hybrid SOFC and GT (Gas Turbine) systems have also been studied extensively in the literature, e.g. in [4] for CHP (Combined Heat and Power). Characterization, quantification and optimization of hybrid SOFC–GT systems have been studied by e.g. [5]. In [6] modeling results are compared with measured data for a 220 kW hybrid planar SOFC–GT power plant. Details on design, dynamics, control and startup of such hybrid power plants are studied in [7]. While hybrid SOFC–GT plants have been extensively studied by many researchers, the investigations on combined SOFC and ST (Steam Turbine) are very limited see [8].

By decreasing the operating temperature of the SOFC stacks, then the combination of SOFC–ST

¹Corresponding author: Phone: +45 45255 4124, Fax: +45 4593 55215, E – mail: MR@mek.dtu.dk

hybrid system would be more attractive than the SOFC–GT systems.

Fuel pre-reforming can be done in different reactors such as ASR (Adiabatic Steam Reformer) and CPO (Catalytic Partial Oxidation). The disadvantages of an ASR reactor is that it needs superheated steam during start-up (depending on the operating temperature of the reactor, i.e. 400°C) which is an extremely power consuming process. During normal operation steam is available after the anode side of the SOFC stacks, which can be recycled into the system. In a CPO reactor additional air is needed for the fuel pre-reforming process, which in turn increases the plant power consumption (compressor power) and thereby the plant efficiency will be decreased. In this study, ASR reforming process versus CPO reforming process is studied in terms of plant design, plant efficiency and plant output power.

A single pressure level for the Rankine cycle is investigated in this study. Plants characteristics of such system configurations are also studied. In addition, the off-gases from the Heat Recovery Steam Generator (HRSG) are used to preheat the incoming air into the SOFC stacks. The effect of such suggested air preheating on plant efficiency and output power is thus studied. All the configurations studied here are novel in terms of designing new plants with very high efficiencies.

METHODOLOGY

The results of this paper are obtained using the simulation tool DNA (Dynamic Network Analysis), see [9–10], which is a simulation tool for energy system analysis.

Some of the important features are:

- Simulation of both steady state (algebraic equations) and dynamic models (differential equations)
- Handling of discontinuities in dynamic equations
- Use of a sparse-matrix-based simultaneous solver for algebraic equations
- No causality implied on the model input, i.e. no restriction of the choice of inputs and outputs
- Medium compositions can be variables
- Models of thermodynamic states, transport

variables and radiative properties for relevant fluids, e.g. steam, ideal gases and refrigerants

The component library includes models of various components such as; heat exchangers, burners, gasifiers, turbo machinery, dryers and decanters, energy storages Engines, valves, controllers, as well as more specialized components and utility components. The user may also implement additional components.

In DNA the mathematical equations include mass and energy conservation for all components, as well as relations for thermodynamic properties of the fluids involved. In addition, the components include a number of constitutive equations representing their physical properties, e.g. heat transfer coefficients for heat exchangers and isentropic efficiencies for compressors and turbines. During the development of DNA the four key terms, portability, robustness, efficiency, and flexibility have been kept in mind for making a generally applicable tool for energy system studies. The program is written in FORTRAN.

Modeling of SOFC

The SOFC model used in this investigation is based on the planar type developed by DTU-Risø and TOPSØE Fuel Cell. The model is calibrated against experimental data in the range of 650°C to 800°C (operational temperature) as described in [11]. The operational voltage (E_{FC}) is found to be

$$E_{FC} = E_{Nernst} - \Delta E_{act} - \Delta E_{ohm} - \Delta E_{conc} - \Delta E_{offset} \quad (1)$$

where E_{Nernst} , ΔE_{act} , ΔE_{ohm} , ΔE_{conc} , ΔE_{offset} are the Nernst ideal reversible voltage, activation polarization, ohmic polarization, concentration polarization and the offset polarization respectively. The activation polarization can be evaluated from Butler–Volmer equation (see [12]). The activation polarization is isolated from other polarization to determine the charge transfer coefficients as well as exchange current density from the experiment by curve fitting technique. It follows,

$$\Delta E_{act} = \frac{RT}{(0.001698T - 1.254)F} \times \sinh^{-1} \left[\frac{i_d}{2(13.087T - 1.096 \times 10^4)} \right] \quad (2)$$

where R , T , F and i_d are the universal gas constant, operating temperature, Faradays constant and current density respectively. Ohmic polarization depends on the electrical conductivity of the electrodes as well as the ionic conductivity of the electrolyte and can be described as

$$\Delta E_{ohm} = \left(\frac{t_{an}}{\sigma_{an}} + \frac{t_{el}}{\sigma_{el}} + \frac{t_{ca}}{\sigma_{ca}} \right) i_d \quad (3)$$

where $t_{an} = 600 \mu\text{m}$, $t_{el} = 50 \mu\text{m}$ and $t_{ca} = 10 \mu\text{m}$ are the anode thickness, electrolyte thickness and cathode thickness respectively. σ_{an} , σ_{el} and σ_{ca} are the conductivity of anode, electrolyte and cathode respectively.

$$\sigma_{an} = 10^5 \quad (4)$$

$$\sigma_{ca} = \frac{5.760 \times 10^7}{T} \exp\left(-\frac{0.117}{8.617 \times 10^{-5} T}\right) \quad (5)$$

$$\sigma_{el} = 8.588 \times 10^{-8} T^3 - 1.101 \times 10^{-4} T^2 + 0.04679 T - 6.54 \quad (6)$$

Concentration polarization is dominant at high current densities for anode – supported SOFC, wherein insufficient amounts of reactants will be transported to the electrodes and the voltage will then reduce significantly. Neglecting the cathode contribution (see e.g. [13]), it can be modeled as

$$\Delta E_{conc} = B \left(-\ln \left(1 + \frac{p_{H_2} i_d}{p_{H_2O} i_{as}} \right) - \ln \left(1 - \frac{i_d}{i_{as}} \right) \right) \quad (7)$$

where B is the diffusion coefficient and is calibrated against experimental data which found to be,

$$B = \left(0.008039 X_{H_2}^{-1} - 0.007272 \right) \frac{T}{T_{ref}} \quad (8)$$

In the above equations p_{H_2} and p_{H_2O} are the partial pressures for the H_2 and H_2O respectively, while T_{ref} is the reference temperature (1023 K). The anode limiting current is defined as

$$i_{as} = \frac{2F p_{H_2} D_{bin} V_{an}}{RT t_{an} \tau_{an}} \quad (9)$$

where V_{an} and τ_{an} are the porosity and tortuosity of the anode and are the physical characteristics as

30% and $2.5 \mu\text{m}$ in the experimental setup. The binary diffusion coefficient is given by

$$D_{bin} = \left(-4.107 \times 10^{-5} X_{H_2} + 8.704 \times 10^{-5} \right) \left(\frac{T}{T_{ref}} \right)^{1.75} \frac{P_{ref}}{P} \quad (10)$$

which is also calibrated against the experimental data. P_{ref} is the reference pressure as 1.013 bar and X_{H_2} is the mass reaction rate of H_2 . Finally the current density i_d is directly proportional to the amount of reacting hydrogen according to the Faraday's law;

$$i_d = \frac{\dot{n}_{H_2} 2F}{A} \quad (11)$$

where \dot{n}_{H_2} is molar reaction rate of H_2 . The area A is the physical property of the cell and is 144 cm^2 .

Modeling of Fuel Pre-Reforming

The reforming process is assumed to be equilibrium by minimizing the Gibbs free energy as described in [13]. The Gibbs free energy of a gas (assumed to be a mixture of k perfect gases) is given by

$$\dot{G} = \sum_{i=1}^k \dot{n}_i \left[g_i^0 + RT \ln(n_i p) \right] \quad (12)$$

where g_i^0 , R and T are the specific Gibbs free energy, universal gas constant and gas temperature respectively. Each atomic element in the inlet gas is in balance with the outlet gas composition, which yields the flow of each atom has to be conserved. For N elements this is expressed as

$$\sum_{i=1}^k \dot{n}_{i,in} \mathbf{A}_{ij} = \sum_{i=1}^k \dot{n}_{i,out} \mathbf{A}_{ij} \quad \text{for } j = 1, N \quad (13)$$

The N elements corresponds to H_2 , CO_2 , H_2O and CH_4 in such pre-reforming process. $\mathbf{A}_{i,j}$ is a matrix with information of the mole j in each mole of i (H_2 , CO_2 , H_2O and CH_4). The minimization of Gibbs free energy can be formulated by introducing a Lagrange multiplier, μ , for each of the N constraints obtained in Eq. (13). After adding the constraints, the expression to be minimized is then

$$\phi = \dot{G}_{out} + \sum_{j=1}^N \mu_j x_j \left[\left(\sum_{i=1}^k \left(\dot{n}_{i,out} - \dot{n}_{i,in} \right) A_{ij} \right) \right] \quad (14)$$

The partial derivation of this equation with respect to $\dot{n}_{i,out}$ can be writes as

$$\frac{\partial \phi}{\partial \dot{n}_{i,out}} = \frac{g_{i,out}^0}{RT} + \ln(n_{i,out} p_{out}) + \sum_{j=1}^k \mu_j A_{ij} \quad \text{for } i = 1, k \quad (15)$$

At the minimum each of these is then zero. The additional equation to make the system consistent is the summation of molar fractions of the outlet gas to be unity.

RESULTS

The first configuration studied is shown in Fig. 1a. The fuel (NG) is preheated in a heat exchanger before it is sent to a desulphurization unit to remove the sulphur content in the NG. This unit is assumed to be using a catalyst, operating at temperature of 200°C. Thereafter the heavier carbon contents in the NG are cracked down in a CPO type pre-reformer catalyst. Before that the fuel must be preheated again to reach to the operational temperature of the CPO catalyst. The CPO catalyst needs additional air which is supplied by a small pump as shown in the figure. It is assumed that the supplied NG is pressurized and therefore no pump is needed for the fuel. The pre-reformed fuel is now sent to the anode side of the SOFC stacks. Due to the exothermal nature of the CPO catalyst, no preheating of the fuel is required. The fuel has a temperature of about 650°C before entering the stacks. The operating temperature of the SOFC stacks as well as outlet temperatures is assumed to be 780°C. The burned fuel after the stacks is used to preheat the fuel using a heat exchanger. On the other side, air is compressed in a compressor and then preheated in a recuperator to about 600°C before entering the cathode side of the SOFC stacks. Lower entering temperature may shut down the stacks

automatically. Since the fuel in the SOFC stacks will not burn completely the rest of the fuel together with the air coming out of the cathode side of the stacks are sent to a burner (catalytic burner) for further burning. The off-gases from the burner have a high heat quality which can be used to generate steam in a Heat Recovery Steam Generator (HRSG).

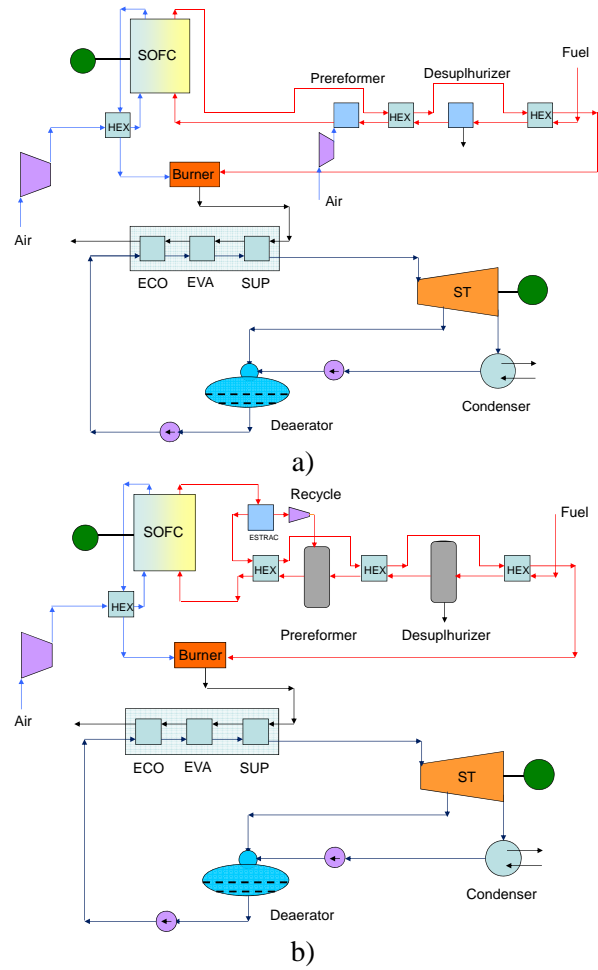

Figure 1. Combined SOFC – ST cycle plants, a) with CPO reformer, and b) with ASR reformer. Rankine cycle with a single pressure level.

In the Rankine cycle, the pressurized water after the feed pump is heated up to steam in the economizer (ECO), evaporator (EVA) and superheater (SUP). The generated steam is then expanded in a steam turbine to generate electricity. Part of the expanded steam is then extracted for the deaerator. The expanded steam is then cooled down in a condenser (including a sub

–cooler part) before pumping to the deaerator. The water is preheated before in the deaerator being recycled. As mentioned earlier the ASR reformer needs super heated steam for operation. Such steam must be supplied to the reformer externally during start-up. However, during normal operation steam is available after SOFC stacks due to reactions of hydrogen and oxygen. Therefore, the stream after the anode side of SOFC is recycled as shown in Fig. 1b. There are three alternatives for such a recirculation unit, a pump, a turbocharger and an ejector. In a real plant, due to high temperature of this stream (more than 700°C) the cost of a pump working will be rather expensive. This is also true for a turbocharger which is working at such mass flows and pressures. Moreover, using an ejector brings up problems associated with the size and dimensioning of the ejector (due to combination of pressure drop and mass flows). Based on these facts and for the sake of simplicity a pump is used in this investigation. Besides the recycle part, the plant configuration is the same as in the CPO reformer case, see Fig. 1b.

The main parameters for the plant are set in table 1. Number of SOFC stacks is assumed to be 10000 and number of cells per stacks is assumed to be 74. The pressure drops in the cathode and anode sides of the fuel cell are assumed to be 0.05 respective 0.01 bars. These values are the setting values for the program, however, pressure drops are a function of channel sizes and mass flows and the channel geometry is not known. Therefore, these values are calculated based on the available data for each channel mass flow and dimensions. In addition, the calculations show that the final values in terms of plant power and efficacy do not change significantly if these values are changed slightly. The SOFC plant provides direct current and must be converted to AC through a converter. Further, the efficiency of the DC/AC converter is assumed to be 100%, due to lack of such component in the DNA program. In reality there would be some losses through the converter and efficiencies of 97% could be assumed for plants of such sizes studied in this investigation. The output power would therefore be somewhat lower while the plant efficiency would not change significantly. Several calculations have been

carried out to find the optimal extraction pressure as well as the optimum live steam pressure which are not included in this study. The main calculated parameters are provided in Table 2.

Parameter	CPO	ASR
Compressor intake T	25°C	25°C
Compressor $\eta_{\text{isentropic}}$	0.85	0.85
Compressor $\eta_{\text{mechanical}}$	0.95	0.95
SOFC cathode inlet T	600°C	600°C
SOFC cathode outlet T	780°C	780°C
SOFC utilization factor	0.80	0.80
SOFC number of cells	74	74
SOFC number of stacks	10000	10000
SOFC cathode side Δp	0.05 bar	0.05 bar
SOFC anode side Δp	0.01 bar	0.01 bar
HEXes pressure drops	0.01 bar	0.01 bar
Fuel inlet temperature	25°C	25°C
Desulphurizer operation T	200°C	200°C
SOFC anode inlet T	650°C	650°C
SOFC anode outlet T	780°C	780°C
Burner efficiency	0.97	0.97
ST isentropic efficiency	0.9	0.9
Feed water pump pressure	70 bar	60 bar
Extraction pressure	2 bar	2 bar
Extraction steam T	120.2°C	120.2°C
Generators efficiency	0.97	0.97

Table 1. Main parameters for design point calculations of Fig. 1.

The main difference in the Rankine cycle from CPO and ASR are the off-gases temperatures entering the HRSG. The CPO pre-reforming plant provides much higher temperature for the off-gases, which is due to the fact that the air mass flow to its burner is lower than the corresponding one for the ASR pre-reforming plant. Consequently, the feeding temperature for the Rankine cycle will be higher in the CPO type, which will result in higher net power from its steam cycle, see Table 3.

The plants net powers and thermal efficiencies (based on LHV, Lower Heating Value) are shown in Table 3. The net power output of the hybrid plant with CPO pre-reforming is calculated to be about 1 MW higher than the corresponding plant with the ASR pre-reforming. The main reason is that the steam cycle in the CPO type plant

produces somewhat higher power than the corresponding ASR type plant (higher off – gases temperature for the CPO pre-reforming). As a result the thermal efficiency of the plant with CPO pre-reforming will be higher than the corresponding plant with ASR pre-reforming.

Parameter	CPO	ASR
Compressor massflow	51.4 kg/s	59.0 kg/s
Fuel massflow	1.32 kg/s	1.30 kg/s
SOFC fuel massflow	1.45 kg/s	1.72 kg/s
Burner fuel massflow	5.17 kg/s	5.13 kg/s
Burner inlet air mass flow	47.7 kg/s	55.1 kg/s
HRSG inlet gas T	526.3°C	455.6°C
HRSG outlet gas T	218.2°C	232.0°C
HRSG inlet water T	121.1°C	121.0°C
ST inlet steam T	496.3°C	425.6°C
ST pressure	69.97 bar	59.97 bar
ST inlet mass flow	6.33 kg/s	5.47 kg/s
Extraction mass flow	5.40 kg/s	4.64 kg/s

Table 2. Main calculated parameters for design point calculations of Fig. 1.

Parameter	CPO	ASR
Net power output	38.03 MW	36.72 MW
SOFC cycle power	31.04 MW	31.23 MW
ST cycle power	6.99 MW	5.49 MW
Steam cycle η_{thermal}	0.382	0.368
SOFC cycle η_{thermal}	0.514	0.524
Plant η_{thermal}	0.630	0.617

Table 3. Net powers and efficiencies of the plants for Fig. 1.

However, the thermal efficiency of the SOFC plant (not the hybrid one) with ASR pre-reforming is calculated to be about 1% higher than the SOFC plant with CPO pre-reforming. This is due to the fact that CPO pre-reforming needs additional air mass flow which must be provided by additional compressor flow (or additional compressor) which in turn needs additional electrical power. In order to optimize the systems presented above, the plants efficiencies versus live steam pressures and moisture contents are presented in Fig. 2.

The results indicate that for the CPO case the maximum efficiency appears to be at about 45 bar

while for the ASR case this maxima is around 22 bar.

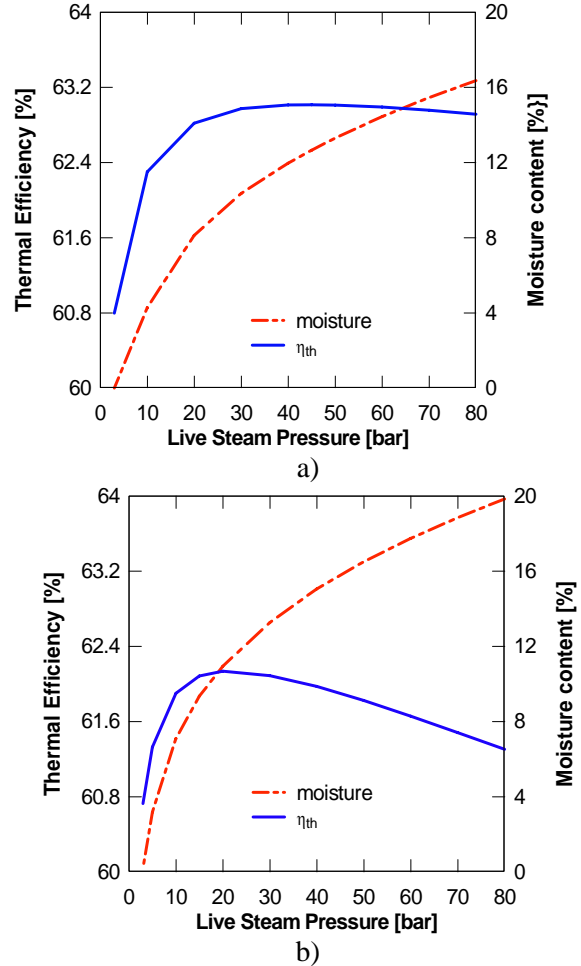

Figure 2. Thermal efficiency and moisture content of the combined SOFC – ST plants as function of live steam pressure, a) with CPO reformer, and b) with ASR reformer.

At optimal live steam pressure the efficiency of the CPO pre-reformer case is higher than the corresponding optimal live steam pressure for the ASR pre-reformer case. The moisture content after the steam turbine is an important issue to be considered. Too high level of moisture (more than about 16%) may cause blades corrosion located at the last stage, see e.g. [15]. Further, the results indicate that for the CPO pre-reforming plant the moisture content more than 16% may occur for pressures above 75 bar, while for the ASR pre-reforming plant this true for pressures above 48bar. Although, both are much higher than the optimized pressures mentioned above.

Effect of Cathode Preheating

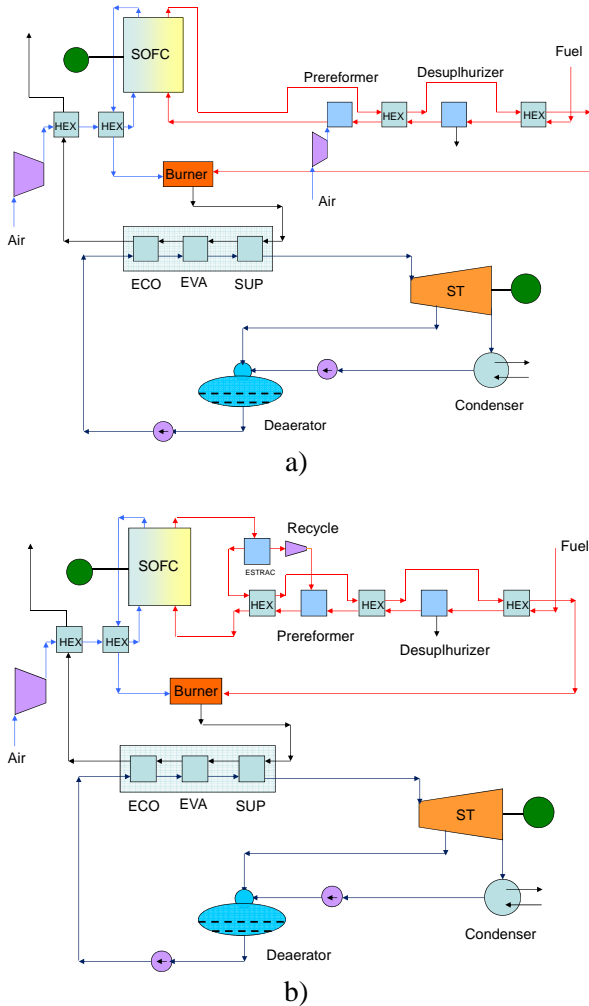

Figure 3. Combined SOFC – ST cycle plants with cathode preheating in the SOFC cycle, a) with CPO reformer, and b) with ASR reformer.

The energy left after the HRSG in the previous designs are rather high; see the outlet temperatures of HRSG in both cases. This energy can be used to preheat the cathode air flow and thereby decrease the energy from the SOFC cycle which is used for preheating. Figure 3 shows the suggested plants. The SOFC cycle efficiency will not decrease significantly by such preheating. Such a preheating cannot be done in a combined cycle (gas turbine on the top of a steam turbine) since the temperature after the compressor is too high because of compressor pressure ratio. Several calculations are carried out to find the

optimal thermal efficiency for each pre-reformer case. Main important calculated results are shown in Table 4. In Table 4, the results are presented for the HRSG outlet gas-side temperature of 90°C. However, the thermal efficiencies of the proposed systems decreases if the HRSG outlet gas temperatures are increased see Fig. 4.

Parameter	CPO	ASR
Net power output	41.06 MW	40.34 MW
SOFC cycle power	30.92 MW	31.13 MW
ST cycle power	10.14 MW	9.21 MW
Dissipated gas T	90°C	90°C
Steam Pressure / Temperature	70 bar / 569.9°C	60 bar / 532.2°C
Steam cycle η_{thermal}	0.395	0.381
Moisture after ST	11.5%	12.9%
SOFC cycle η_{thermal}	0.512	0.523
Plant η_{thermal} (LHV)	0.680	0.677

Table 4. Net powers and efficiencies of the plants for Fig. 3.

At 120°C the thermal efficiency of the CPO case drops to 0.668, while for the ARS it is decreased to 0.664. However, these efficiencies are still much higher compared to the traditional plants for such sizes. Further, the drop in efficiency for the ASR pre-reforming case is more sensible than the CPO case, the lines are getting wider.

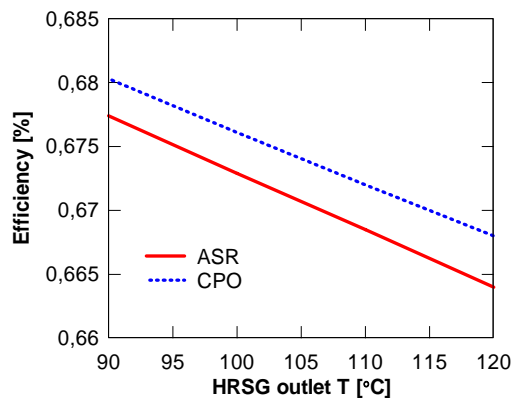

Figure 4. Thermal efficiencies as function of HRSG outlet gas temperature.

CONCLUSIONS

Hybrid combined SOFC – ST plants are presented and analyzed. The plants are fired by natural gas

and therefore the fuel is desulfurized and then pre-reformed before sending to the anode side of the SOFC. Both CPO and ARS pre-reforming processes are used.

The results indicate that for simple combinations the thermal efficiencies of the system can reach to about 62% – 63 % depending on the pre-reforming process. The SOFC cycle efficiency in the ASR performing type is higher than the corresponding SOFC cycle with CPO pre-reforming. However, the efficiency of the hybrid plants with CPO case is larger than the corresponding hybrid plant with ARS case. This is due to the fact that in the CPO case the temperature of the off-gases entering the HRSG is larger than the corresponding temperature in the ARS case. This results in higher efficiency in the bottoming cycle (steam cycle) and thereby better efficiency for the hybrid plant. Using cathode preheating the efficiency will be increased to about 67% – 68%.

REFERENCES

- [1] Fontell, E., Kivisaari, T., Christiansen, N., Hansen, J.-B. and Pålsson, J. 2004, "Conceptual study of a 250 kW planar SOFC System for CHP Application", *J. Power Sources*, Vol. 131, pp. 49 – 56.
- [2] Rokni, M., 2003, "Introduction of a Fuel Cell into Combined Cycle: A Competitive Choice for Future Cogeneration", *ASME Cogen – Turbo*, IGTI vol. 8, pp. 255 – 261.
- [3] Riensche, E., Achenbach, E., Froning, D., Haines, M. R., Heidug, W. K., Lokurlu, A., and von Andrian, S., 2000, "Clean Combined-cycle SOFC Power Plant – Cell Modeling and Process Analysis", *J. Power Sources*, Vol. 86, pp. 404 – 410.
- [4] Pålsson, J., Selimovic, A. and Sjunnesson, L., 2000 "Combined Solid Oxide Fuel Cell and Gas Turbine System for Efficient Power and Heat Generation", *J. Power Sources*, Vol. 86, pp. 442 – 448.
- [5] Subramanyan, K. and Diwekar, U. M., 2005 "Characterization and Quantification of Uncertainty in Solid Oxide Fuel Cell Hybrid Power Plants", *J. Power Sources*, Vol. 142, pp. 103 – 116.
- [6] Roberts, R. A. and Brouwer, J. 2006, "Dynamic Simulation of a Pressurized 220 kW Solid Oxide Fuel-Cell – Gas-Turbine Hybrid System: Modeled Performance Compared to measured Results", *J. Fuel Cell Science and Technology*, Vol. 3, No. 1, pp. 18 – 25.
- [7] Rokni, M., Fontell, E., Ylijoki, Y., Tiihonen, O., Hänninen, M., 2005, "Dynamic Modeling of Wärtsilä 5kW SOFC System", Ninth International Symposium on Solid Oxide Fuel cell (SOFC IX), Quebec, Eds. S.C. Singhal and J. Mizusaki, pp. 865 – 875.
- [8] Dunbar, W.R., Lior, N., Gaggioli, R.A., 1991, "Combining Fuel Cells with Fuel – Fired Power Plants for Improved Exergy Efficiency". *J. of Energy*, Vol. 16, No. 10, pp. 1259 – 1274.
- [9] Elmegaard, B, Houbak, N, 2005, "DNA – A General Energy System Simulation Tool," Proceeding of SIMS 2005, Trondheim, Norway.
- [10] Petersen, T.F., Houbak, N. and Elmegaard, B., 2006, "A Zero-Dimensional Model of a 2ND Generation Planar SOFC With Calibrated Parameters", *Int. J. Thermodynamics*, Volume 9, issue 4, pp. 161 – 168.
- [11] Keegan, K. M., Khaleel M., Chick L. A., Recknagle K., Simner S.P. and Diebler J., 2002, "Analysis of a Planar Solid Oxide Fuel Cell Based Automotive Auxiliary Power Unit", *SAE Technical Paper Series No. 2002-01-0413*.
- [12] Kim, J.W. and Virkar, A.V., 1999, "The Effect of Anode Thickness on the Performance of Anode – Supported Solid Oxide Fuel Cell", *Proc. of the Sixth Int. Symp. On SOFCs*, (SOFC – VI), PV99 – 19, The Electrochemical Society, pp. 830 – 839.
- [13] Elmegaard, B, Houbak, N, 1999, "On the Implementation of Energy Simulators with Emphasis on Chemical Equilibrium Gasifier Models", Proceedings of ECOS'99 (ISBN: 4-9980762-0-5), pp. 258-263, Tokyo.
- [14] Kehlhofer, R.H., Warner, J., Nielsen, H. and Bachmann, R., 1999, "Combined – Cycle Gas Steam Turbine Power Plants", PennWell, ISBN: 0-87814-736-5.