

Technical University of Denmark



Simultaneous Fleet Deployment and Network Design of Liner Shipping

Gelareh, Shahin; Pisinger, David

Publication date:
2010

Document Version
Publisher's PDF, also known as Version of record

[Link back to DTU Orbit](#)

Citation (APA):
Gelareh, S., & Pisinger, D. (2010). Simultaneous Fleet Deployment and Network Design of Liner Shipping. Kgs. Lyngby: DTU Management. (DTU Mananagement 2010; No. 14).

DTU Library Technical Information Center of Denmark

General rights

Copyright and moral rights for the publications made accessible in the public portal are retained by the authors and/or other copyright owners and it is a condition of accessing publications that users recognise and abide by the legal requirements associated with these rights.

- Users may download and print one copy of any publication from the public portal for the purpose of private study or research.
- You may not further distribute the material or use it for any profit-making activity or commercial gain
- You may freely distribute the URL identifying the publication in the public portal

If you believe that this document breaches copyright please contact us providing details, and we will remove access to the work immediately and investigate your claim.

Simultaneous Fleet Deployment and Network Design of Liner Shipping

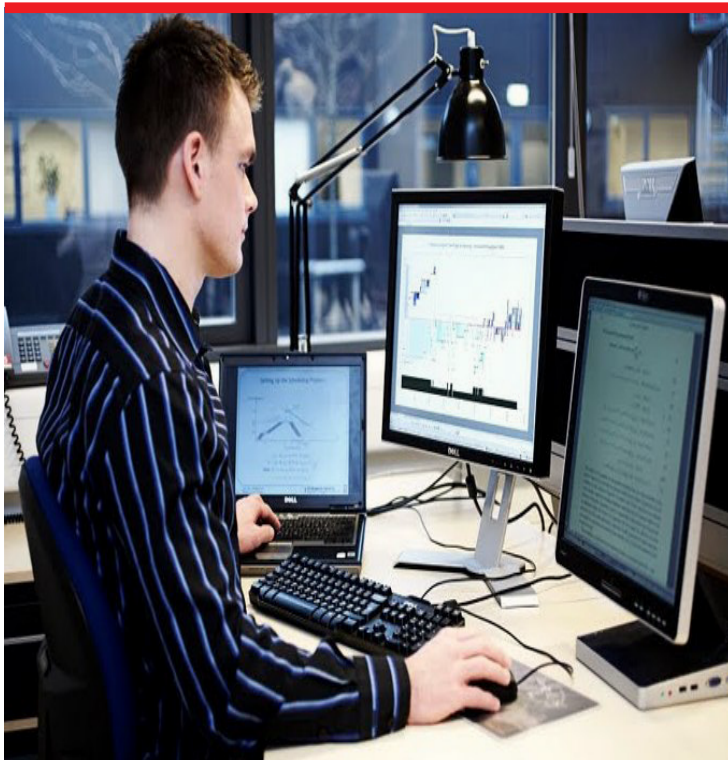

Report 14.2010

DTU Management Engineering

Shahin Gelareh
David Pisinger
June 2010

Simultaneous Fleet Deployment and Network Design of Liner Shipping Companies

Shahin Gelareh^{a,1,*}, David Pisinger^a

^a*Department of Management Engineering, Technical University of Denmark, Produktionstorvet, Building 426, 2800 Kgs. Lyngby, Denmark*

Abstract

A mixed integer linear programming formulation is proposed for the simultaneous design of network and fleet deployment of a liner service providers for deep-sea shipping. The underlying network design problem is based on a 4-index (5-index by considering capacity type) formulation of the hub location problem which are known for their tightness. The demand is considered to be elastic in the sense that the service provider can accept any fraction of the origin-destination demand. We then propose a primal decomposition method to solve instances of the problem to optimality. Numerical results confirm superiority of our approach in comparison with a general-purpose mixed integer programming solver.

Keywords: hub-and-spoke network design, liner shipping, fleet deployment, elastic demand, mixed integer programming, Benders decomposition.

1. Introduction

Maritime transportation offers cheaper rates, higher safety levels and less environmental effects than most comparable transportation modes. In the last decades maritime transportation has played a still larger role in the international trade, due to the strong and rapid growth in the world economy resulting in larger volume of production. However, increasing focus on environmental issues, and the economical crisis in 2009 has made it necessary to find sustainable solutions for the maritime sector.

According to (Christiansen et al., 2004) shipping operation can be grouped in three categories: (a) liner shipping, (b) industrial shipping and (c) tramp shipping. In this paper we focus on *containerized liner shipping* since it is specialized in providing reliable and regular services between ports along known sailing routes, and it is used in a large extent for long haul transport of high value goods.

By May 2008, the world containership fleet reached approximately 13.3 million twenty-foot equivalent unit (TEUs), of which 11.3 million TEUs were on fully cellular containerships. This fleet includes 54 containerships of 9,000 TEU and above. A forecast ending in 2020 indicated that container trade is expected to reach 219 million TEUs in 2012 and 287 million TEUs in 2016, and to exceed 371 million TEUs in 2020. For more details one can refer to ISL (2008). The drive to bigger containerships which carry still more containers is largely due to the fuel price and the economy of scale. It is claimed that new jumbo vessels (22,000 TEUs capacity) would cut the shipping price per container by 40%. Therefore, vessel size has significant impact on the shipping operations.

With larger vessels, it gets still more important to design the route net such that a good utilization of the capacity is achieved. Within a given planning horizon, it is vital for the liner shipping operators to determine an optimal allocation of vessels to routes and the relevant vessel chartering strategy in order to minimize the total operating cost and to keep a satisfactory service level for customers. For the sake of presentation, this decision problem is referred to as the *fleet deployment problem* (FDP). In contrast with the above-mentioned trend of increase in capacity and fleet size of the

*Corresponding author (Tel: +45 4525 3386)
Email address: shge@man.dtu.dk (Shahin Gelareh)

maritime transport industry, not many studies have been carried out on the FDP. Our model is intended to be used one region at a time.

Not all ports are accessible by the large vessels due to draught, unloading facilities or capacity. Also, it can be undesirable to call too many ports on a round-trip with the large vessels since each call takes time and implies additional expenses. This has led to a still larger use of *hub and spoke* networks, where the hub network is maintained by large vessels, while the spoke network is maintained by smaller feeder lines.

During the last two decades, hub-and-spoke network design problems have received increasing attention in a wide range of application areas such as transportation, telecommunications, computer networks, postal delivery, less-than-truck loading (LTL) and supply chain management. The economy of scale offered by hub-and-spoke network structures for transferring origin-destination (O-D) flows is exploited by concentrating flow on fewer links and by avoiding underutilized connections.

Aiming at minimizing the total costs in a hub-and-spoke network, flow between O-D pairs is routed through some selected intermediate nodes (called *hub nodes*) and edges (called *hub edges*) connecting the hubs. Once the hubs are chosen, the non-hub nodes (called *spoke nodes*) are allocated to the hubs in order to transship flow via the hub-level sub-network. The allocation scheme is either *single* or *multiple* based on the particular nature of application. In a single allocation scheme, a spoke node is allocated to a single hub, while such a restriction is relaxed in a multiple allocation scheme. A hub-and-spoke structure avoids direct shipping concentrating flow on hub edges to get a better utilization of facilities operating there. As a result of this flow concentration, economy of scale can be exploited by using more efficient vessels on the hub links.

In the present paper we present a model for simultaneous network design and fleet deployment. The model is able to determine a cyclic hub network, and to find the capacity of the hub line and feeder lines. The model is intended to be used for a single region, hence only one hub line is considered, and the number of ports is limited to 10-20.

Although simultaneous network design of a hub-and-spoke network and fleet deployment has not been addressed before in the literature, each of the parts have been studied intensively, as we summarize in the sequel.

1.1. Network Design

Within the area of liner shipping only a few references are found and they mainly concern deployment of vessels (Ronen et al., 2004). Christiansen et al. (2007) describe models for designing shipping networks for a traditional liner operation as well as for a hub-and-spoke liner network. According to the paper, a booking is accepted if there is space available on a vessel. This may lead to non-optimal decisions since the space may be used more profitably by demands in subsequent ports on the route. However, the issue of empty container availability is not regarded as a component of cargo profitability, although the connection to profit is evident. The paper encourages research into the area of revenue management and booking models, but very little work has been published on this subject as mentioned by, e.g., Ronen et al. (2004); Christiansen et al. (2007). To the best of our knowledge the only work is the paper by Løfstedt et al. (2010).

Ships routing and scheduling has been addressed by e.g. Cho and Perakis (1996), Ronen (1983, 1993), Christiansen et al. (2004), Bremer and Perakis (1992); Perakis and Bremer (1992), Kim and Lee (1997), Cho and Perakis (2001), Reddy et al. (2004), Brønmo et al. (2007), Korsvik and Fagerholt (2008) and Alizadeh and Nomikos (2007).

Recently, Lium et al. (2009) presented a stochastic model for the service network design problem. Hoff et al. (2009) presented a metaheuristic for stochastic network design based on Neighborhood Search and changes of neighborhood in different phases of the search. Reinhardt et al. (2010) presented a branch and cut algorithm for the (deterministic) network design problem. More recently, Gelareh et al. (2010) proposed a competitive hub location problem for designing liner shipping networks.

1.2. Fleet Deployment Problem

Everett et al. (1972) was the first to propose a linear programming model to optimize a fleet of large tankers and bulkers in the USA (Bradley et al., 1977). Mathematical models for various variants of the FDP have been presented by Perakis and Jaramillo (1991); Jaramillo and Perakis (1991); Powell and Perakis (1997). This includes a nonlinear programming model for FDP with multiple origins and destinations (Papadakis and Perakis (1989)) and FDP with single origin-destination pairs and multiple vessels (Perakis and Papadakis (1987a,b)). Perakis (2002) gives a survey of fleet operation and deployment optimization up to 2002. A slightly different version of the FDP is also examined

by (Shintani et al., 2007), which takes into consideration the empty container repositioning issues. Gelareh and Meng (2010) proposed a more general model by simultaneously taking into consideration many factors.

1.3. Hub Location Problem

In the present paper we consider a discrete hub location problem. The first work in this area is due to O’Kelly (1987), who proposed the first (quadratic) mathematical formulation for the *Uncapacitated Single Allocation p-Hub Median Problem* (USApHMP).

Aversa et al. (2005) proposed a mixed integer programming (MIP) model for locating a hub port in the East coast of South America. In 2008, Takano and Arai (2008) applied the quadratic model of O’Kelly and developed a genetic algorithm to solve instances of the problem. As opposed to many existing tight linear formulations, this work applies a nonlinear formulation; it neither allows more than one hub edge being used along any O-D path nor any spoke-spoke connection. Imai et al. (2009) presented a model for simultaneous hub-and-spoke network design and fleet deployment problems in liner shipping. Their emphasis is on the empty container repositioning and their model hardly resembles a standard hub-and-spoke model. Imai et al. (2006) studies the viability of deploying mega-vessels by employing a non-zero sum two-person game with hub-and-spoke networks strategy for mega-vessels and multi-port calling for conventional ship size. Other results can be found in Hsu and Hsieh (2007) for a bi-objective model to determine the optimal liner routing, ship size, and sailing frequency for container carriers by minimizing shipping costs and inventory costs. Konings (2006) tries to answer the question whether hub-and-spoke services could be a fruitful tool in improving the performance of Container-on-barge transport and so in gaining market share.

Other works addressing liner shipping network design, but not necessarily the hub-and-spoke design, include Choong et al. (2002) for empty container management for intermodal transportation networks.

For a recent survey of models, applications and solution methods for network hub location problems, we refer to the survey by Alumur and Kara (2008) and the references therein.

1.4. Objective and Contribution

When compared to most other modes of transportation, liner shipping offers cheaper freight rates, higher safety level and less environmental impact compared to most other transportation means. However, from a scientific point of view, liner shipping has until recently received less attention in the literature. The current trend of global trade and emerging new economies UNCTAD (2008)—in particular in Asia—enhance the importance of liner shipping, since it is in charge of transporting up to 90 percent of this trade volume.

From the liner service providers point of view offering deep-sea services, fuel consumption is a major part of their costs (up to 49 percent). Different policies are implemented to keep fuel cost under control and to ensure a better utilization of the vessels in order to reach lower operational costs. From among such policies, so called *slow steaming* helps liner service providers to reduce bunker costs while maintaining the published itinerary plan valid and respected. However, such policies often are applied on known networks without having a holistic approach which takes into account deployment at the same time as network design. Besides this, most models presented in the literature assume that the LSPs are obliged to transport the whole demand which is seldom the case in reality. In practice, although LSPs are bound to a given frequency of rotations and often have a lot of contracts, neither the shippers have to deliver anything (if for example demand is not generated and canceled because of production disruption) nor LSPs are obliged to serve the whole demand of customers if for example they have over booked board.

We have considered the following issues in our model: i) the LSPs can choose what fraction of the demand they want to accept to transport, ii) they can choose to deploy on feeder network or to not operate a feeder line but still receive the demand, perhaps through a third-party, iii) the regular service is guaranteed and the model offers a high level of flexibility and extendibility to be used by different LSPs. Many practical aspects such as consistency between ports and vessels etc can be expressed in the model, iv) the cost of transshipment is explicitly considered in the model, v) the model considers at the service network design problem for a given fleet of vessels and tries to maximize the utilization w.r.t the existing resources rather than designing an ideal network for a non-existing fleet, vi) in practice the global trade transport has a regional pattern like Europe-North America, Europe-Asia Pacific etc. hence the presented model is intended for use in regional planning.

Although the main contribution of the work is to propose a comprehensive mathematical model, the model has carefully been designed such that it can be decomposed in order to make use of the novel techniques presented in

literature. The proposed primal decomposition is able to determine the quality of the solution by boxing the optimal value between a lower and upper bound, even when stopped before proving optimality. This paper is organized as follows: In Section 2, we formally state and describe the problem. In Section 3, a mathematical model is proposed and its properties are investigated. Section 4 presents a solution method based on Benders decomposition. The master problem is defined, and it is shown how to separate cuts from the dual solution. New branching rules are presented as well as techniques for preprocessing the graph in order to reduce the problem size. In Section 5, we report our computational experiments which show that the decomposed algorithm is considerably faster than solving the original model by general-purpose solver. The work is concluded in Section 6 where we also suggest further research directions.

2. Problem Statement

The Fleet Deployment on a Hub Location Network (FDHLN) can formally be stated as follows: Given a set of ports each of which has at least one container terminal and also given:

- a) origin-destination (O-D) flows between every pair of ports,
- b) a finite fleet of vessels of certain types with respect to capacity, size and particular traits,
- c) running cost per unit of TEU for every vessel type and for every leg,
- d) revenue generated per unit of flow for every vessel type and every leg of call,
- e) fixed deployment cost for every vessel type (independent of leg of call) and,
- f) transshipment cost per unit of flow (TEU) at any port along an O-D path.

The problem is to find a circular route (hub-level loop sub-network) in the region of service passing through a set of designated hub ports, such that the remaining non-hub (spoke) ports send their demands using feeder vessels to a finite and limited number (usually restricted to two) ports on the circular route. The problem seeks for:

- i) a directed hub-level circular route subject to a bounded travel time,
- ii) allocation of spoke ports to the hub ports on the circular route,
- iii) assignment of optimal vessel type and arrival frequency to each spoke link,
- iv) determining the fraction of the O-D demand to be fulfilled and,
- v) assignment of an optimal number of a unique vessel type on the circular route,

in such a way that the overall return after deduction of costs (transport, deployment, transshipment) is maximized. Figure 1 sheds more light on the structure of such a network.

It is natural to assume that the running cost per TEU is lower using larger vessels. This is in our model expressed by a vessel-dependent discount factor α_v on the running costs, when using vessel v .

3. Mathematical Model

We first need to introduce the notation before presenting the model.

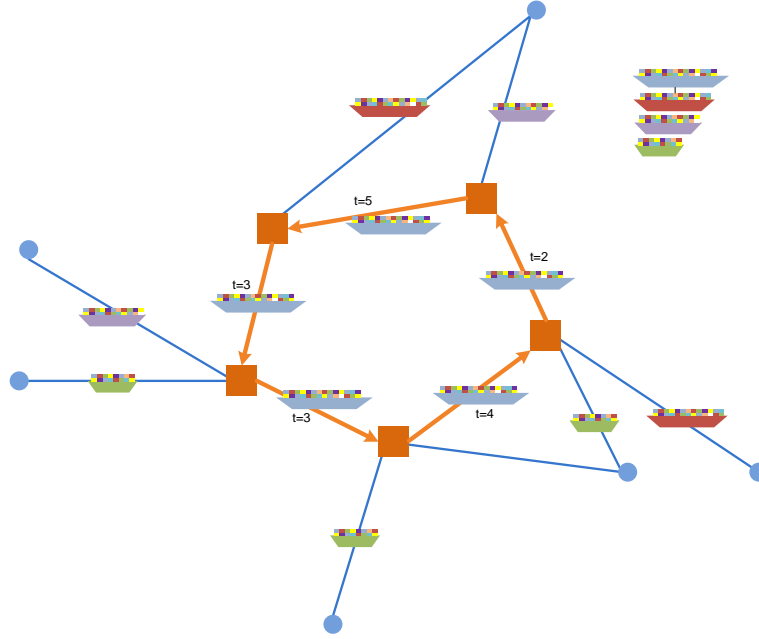

Figure 1: A typical solution to the problem. Four vessel types are available as illustrated in the upper right corner. The hub network is marked with red (square nodes and connecting directed links), while the feeder lines are marked with blue (circles and undirected links). Type of vessels is indicated on the edges.

3.1. Parameters

The parameters are listed here:

Parameters	
\mathcal{N}	number of ports
\mathcal{N}^{alloc}	maximum number of hub nodes that a spoke node can be allocated to
\mathcal{S}	set of all vessel types
N_v	maximum number of available vessels of type $v \in \mathcal{V}$
α_v	discount factor resulted from economy of scale in using vessel type v on the hub-level network
r_{klv}	revenue generated per TEU on leg (k, l) using vessel type v
C_k^{tr}	transshipment cost per TEU at port k
T_H^{min}	minimum length of string
T_H^{max}	maximum length of string
C^v	capacity of vessel type v
F_v^{dep}	fixed deployment cost of vessel type v
w_{ij}	demand between port i and j from i to j (TEU)
c_{ij}	cost per TEU for direct transport from port i to j

3.2. Decision Variables

The decision variables are listed in the following table:

Variables	
e_{ij}^v	fraction of flow from i to j on a feeder link between a hub port and a feeder port
a_{ijk}^v	fraction of flow from i to j that first arrives to hub port k from spoke port i
b_{ijk}^v	fraction of flow from i to j that uses last spoke edge (k, j) where k is a hub and j is a spoke edge to arrive destination
x_{ijkl}^v	fraction of flow from i to j that chooses to traverse hub edge (k, l) along its path to destination
y_{kl}	1 if hub edge is installed between k and l , 0 otherwise
n_{vij}^S	number of vessels of type v deployed on spoke link
n_{vij}^H	number of vessels of type v deployed on hub link
n_v^H	number of vessel type v in the hub level, 0 otherwise
V_{vkl}^H	1 if vessel type v is deployed on hub link (k, l) , 0 otherwise
V_{vkl}^S	1 if vessel type v is deployed on hub link (k, l) , 0 otherwise
V_v^H	1 if vessel type v is deployed on the circle, 0 otherwise

In what follows, we use 'node' and 'port' and also 'spoke' and 'feeder' interchangeably.

3.3. Formulation

The FLEET DEPLOYMENT ON HUB-AND-SPOKE NETWORK(FDHSN) is formulated as follows

$$\begin{aligned}
\max \quad & \sum_{i,j \in \mathcal{N}} \sum_{v \in \mathcal{V}} e_{ij}^v (r_{ij}^v - c_{ij}^v) w_{ij} \\
& + \sum_{i,j,k \in \mathcal{N}} \sum_{v \in \mathcal{V}} a_{ijk}^v (r_{ik}^v - c_{ik}^v) w_{ij} + \sum_{i,j,k \in \mathcal{N}} \sum_{v \in \mathcal{V}} b_{ijk}^v (r_{jk}^v - c_{jk}^v) w_{ij} && \text{(transport profit)} \\
& + \sum_{i,j,k,l \in \mathcal{N}} \sum_{v \in \mathcal{V}} \alpha_v x_{ijkl}^v (r_{kl}^v - c_{kl}^v) w_{ij} \\
& - \sum_{i,j,k \in \mathcal{N}} \sum_{v \in \mathcal{V}} (a_{ijk}^v + b_{ijk}^v) w_{ij} c_k^{tr} && \text{(transshipment cost)} \\
& - \sum_{k,l > k \in \mathcal{N}} \sum_{v \in \mathcal{V}} n_{vkl}^S c^v - \sum_{k,l \neq k \in \mathcal{N}} \sum_{v \in \mathcal{V}} n_{vkl}^H c^v && \text{(fixed deployment)} \quad (1)
\end{aligned}$$

s.t.

$\mathcal{G}1$

$$\sum_v \left(e_{ij}^v + \sum_{k \neq i,j} a_{ijk}^v + \sum_{k \neq i} x_{ijk}^v \right) \leq 1, \quad i, j \neq i \in \mathcal{N}, \quad (2)$$

$$\sum_v \left(e_{ij}^v + \sum_{k \neq i,j} b_{ijk}^v + \sum_{k \neq j} x_{ijk}^v \right) \leq 1, \quad i, j \neq i \in \mathcal{N}, \quad (3)$$

$$\sum_v \left(\sum_{l \neq k,i} x_{ijkl}^v - \sum_{l \neq k,j} x_{ijkl}^v - a_{ijk}^v + b_{ijk}^v \right) = 0, \quad j \neq i, k \neq i, j \in \mathcal{N} \quad (4)$$

$\mathcal{G}2$

$$y_{kl} \leq y_{kk}, \quad y_{kl} \leq y_{ll}, \quad k, l \neq k \in \mathcal{N}, \quad (5)$$

$$\sum_{l \neq k} (y_{kl} + y_{lk}) = 2y_{kk}, \quad k \in \mathcal{N}, \quad (6)$$

$$\sum_{l \neq k} y_{kl} \leq 1, \quad k \in \mathcal{N}, \quad (7)$$

$\mathcal{G}3$

$$\sum_{l \neq k} \sum_{v \in \mathcal{S}} x_{ijkl}^v \leq 1 - s_{ik}, \quad i, j \neq i, k \neq i, j \in \mathcal{N}, \quad (8)$$

$$\sum_v e_{ij}^v + y_{ii} + y_{jj} \leq 2, \quad i, j \neq i \in \mathcal{N}, \quad (9)$$

$$\sum_v e_{ij}^v - y_{jj} - y_{ii} \leq 0, \quad i, j \neq i \in \mathcal{N}, \quad (10)$$

$$\sum_v e_{ij}^v \leq s_{ij} + s_{ji}, \quad i, j \neq i \in \mathcal{N}, \quad (11)$$

$$\sum_v a_{ijk}^v + \sum_v \sum_{l \neq k} x_{ijlk}^v - y_{kk} \leq 0, \quad i, j, k \neq i, j \neq i \in \mathcal{N}, \quad (12)$$

$$\sum_v b_{ijk}^v + \sum_v \sum_{l \neq k} x_{ijkl}^v - y_{kk} \leq 0, \quad i, j \neq i, k \neq i, j \in \mathcal{N}, \quad (13)$$

$$\sum_v a_{ijk}^v + y_{ii} \leq 1, \quad i, j \neq i, k \neq i, j \in \mathcal{N}, \quad (14)$$

$$\sum_v b_{ijk}^v + y_{jj} \leq 1, \quad i, j \neq i, k \neq i, j \in \mathcal{N}, \quad (15)$$

$$\sum_v a_{ijk}^v \leq s_{ik} + s_{ki}, \quad i, j \neq i, k \neq i, j \in \mathcal{N}, \quad (16)$$

$$\sum_v b_{ijk}^v \leq s_{jk} + s_{kj}, \quad i, j \neq i, k \neq i, j \in \mathcal{N}, \quad (17)$$

$$\sum_v x_{ijkl} \leq y_{kl}, \quad i, j \neq i, k \neq l \in \mathcal{N}, \quad (18)$$

$$\mathcal{G}4 \quad \sum_{j \neq i} s_{ij} \leq N^{alloc} s_{ii}, \quad i \in \mathcal{N}, \quad (19)$$

$$\mathcal{G}5 \quad s_{ii} + y_{ii} = 1, \quad i \in \mathcal{N}, \quad (20)$$

$$s_{ij} + s_{ji} \leq 1, \quad i, j \neq i \in \mathcal{N}, \quad (21)$$

$$y_{ij} + y_{ji} \leq 1, \quad i, j \neq i \in \mathcal{N}, \quad (22)$$

$$s_{ij} \leq 2 - y_{ii} + y_{jj}, \quad i, j \neq i \in \mathcal{N}, \quad (23)$$

$$\mathcal{G}6 \quad T_H^{min} \leq \sum_{k, l \neq k} t_{kl} y_{kl} \leq T_H^{max} \quad (24)$$

$$\mathcal{G}7 \quad \sum_v C^v (n_{vkl}^H + n_{vlk}^H) \geq \sum_{i, j \neq i} \sum_v x_{ijkl}^v w_{ij}, \quad k, l \neq k \in \mathcal{N}, \quad (25)$$

$$\sum_v C^v n_{vkl}^S \geq \sum_{i \neq k, l} \sum_v a_{kil}^v w_{ki} + \sum_{i \neq k, l} \sum_v b_{ilk}^v w_{il} + \sum_v e_{kl}^v w_{kl}, \quad k, l \neq k \in \mathcal{N}, \quad (26)$$

$$\sum_v C^v n_{vkl}^S \geq \sum_{j \neq k, l} \sum_v a_{ljk}^v w_{lj} + \sum_{j \neq k, l} \sum_v b_{jkl}^v w_{jk} + \sum_v e_{lk}^v w_{lk}, \quad k, l \neq k \in \mathcal{N}, \quad (27)$$

$\mathcal{G}8$

$$\sum_{l \neq k} n_{vkl}^H = \sum_{l \neq k} n_{vlk}^H, \quad v \in \mathcal{S}, k \in \mathcal{N} \quad (28)$$

$\mathcal{G}9$

$$\sum_v V_{vkl}^S \leq s_{kl} + s_{lk}, \quad k, l \neq k \in \mathcal{N}, \quad (29)$$

$$\sum_v V_{vkl}^H = y_{kl}, \quad k, l \neq k \in \mathcal{N}, \quad (30)$$

$\mathcal{G}10$

$$n_v^H \geq n_{vkl}^H, \quad v \in \mathcal{S}, k, l \neq k \in \mathcal{N} \quad (31)$$

$$n_v^H \leq V_v^H N_v^{max}, \quad v \in \mathcal{S}, k, l \neq k \in \mathcal{N} \quad (32)$$

$$n_{vkl}^H \leq V_{vkl}^H N_v^{max}, \quad v \in \mathcal{S}, k, l \neq k \in \mathcal{N} \quad (33)$$

$$n_{vkl}^H \leq y_{kl} N_v^{max}, \quad v \in \mathcal{S}, k, l \neq k \in \mathcal{N} \quad (34)$$

$$n_{vkl}^H \leq (1 - s_{kl} - s_{lk}) N_v^{max}, \quad v \in \mathcal{S}, k, l \neq k \in \mathcal{N} \quad (35)$$

$$n_{vkl}^S \leq V_{vkl}^S N_v^{max}, \quad v \in \mathcal{S}, k, l \neq k \in \mathcal{N} \quad (36)$$

$$\sum_{k,l>k} n_{vkl}^S + n_v^H \leq N_v^{max}, \quad v \in \mathcal{S}, \in \mathcal{N} \quad (37)$$

$\mathcal{G}11$

$$V_{vkl}^S = V_{vkl}^S, \quad k, l > k \in \mathcal{N}, v \in \mathcal{S} \quad (38)$$

$$n_{vkl}^S = n_{vkl}^S, \quad k, l > k \in \mathcal{N}, v \in \mathcal{S} \quad (39)$$

$\mathcal{G}12$

$$\sum_v V_v^H = 1, \quad (40)$$

$$\sum_{l \neq k} x_{ijkl}^v \leq V_v^H, \quad i, j \neq i, k \in \mathcal{N}, v \in \mathcal{S} \quad (41)$$

$$a_{ijk}^v \leq V_{vik}^S, \quad i, j \neq i, k \neq i, j \in \mathcal{N}, v \in \mathcal{S} \quad (42)$$

$$b_{ikj}^v \leq V_{vjk}^S, \quad i, j \neq i, k \neq i, j \in \mathcal{N}, v \in \mathcal{S} \quad (43)$$

$$e_{ij}^v \leq V_{vij}^S, \quad i, j \neq i \in \mathcal{N}, v \in \mathcal{S} \quad (44)$$

Constraints (2)-(4) are flow conservation constraints for elastic flow. It is basically assumed that the service is flexible in the sense that a carrier can choose to pick up any fraction of the flow. Constraints (5)-(7) ensure that both endpoints of a hub edge are hub nodes (ports), the degree (in-degree plus out-degree) of every hub node is either two or zero and at most one directed hub arc is radiated from a hub port. Constraints (8)-(18) ensure that for e_{ij} only one node is hub node (port), for a_{ijk} and b_{ijk} the k , i.e. transshipment port, must be hub a node (port), for a_{ijk} , i must be a spoke node, for b_{ijk} , j must be spoke node and for x_{ijkl} , (k, l) must be a directed hub arc. The number of hub nodes that a spoke is allocated to is limited to N^{alloc} . This is guaranteed by (19). Constraints (20)-(23) indicate that either a node is a hub node or spoke node, spoke links are undirected, hub arcs are directed, and spoke nodes do not have both spoke endpoints. The total travel time on the hub-level network is restricted by (24). The required number of vessels to fulfill the existing demand on each link is determined by (25)-(27). Constraint (28) indicates the consistency in the number of vessels on the hub level network edges. Constraints (29)-(30) determine the vessel type on each link. To respect the number of available vessels (31)-(37) are considered. Consistency in the vessel type and number on the spoke links are determined in (38)-(39). The consistency between vessel type and corresponding flow variables are taken into account in (40)-(44).

A typical network design output of (FDHSN) is depicted in Figure 2. The square nodes on the directed string represent the nominated hub ports and the circular nodes are the spoke ports allocated to hub ports.

4. Solution Method

We have observed difficulties for general-purpose mixed integer programming solvers to solve instances of even very small size (e.g. $n = 10$) and therefore our aim in this section is to propose a decomposition algorithm to solve larger instances in reasonable time.

A trivial decomposition for (FDHSN) is to decompose the problem to a master problem for simultaneous network design and deployment and an elastic flow problem as a subproblem. We exploit the carefully designed model and the structure of problem to split the variables following the principle of Benders decomposition (Benders (2005)).

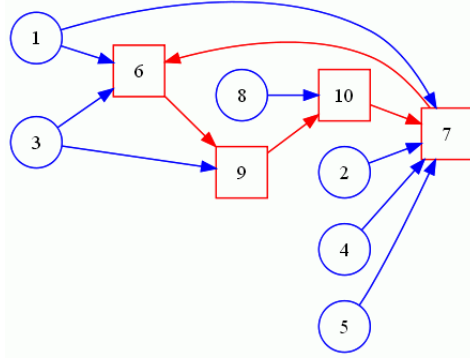

Figure 2: A typical network structure of (FDHSN). The square nodes on the directed string represent the nominated hub ports and the circular nodes are the spoke ports allocated to hub ports.

The idea of Benders decomposition is to partition set of decision variables into complicating (usually integer) and non-complicating ones (usually continuous), relaxing the complicating variables.

Since this pioneering work of Benders, many successful application of this approach are reported in literature. There are also works which in particular address the application of Benders decomposition for network design problems. Interested readers are referred to Magnanti and Wong (1981) and Magnanti et al. (1986). Recently, Poojari and Beasley (2009) studied the ways to improve the performance of approach by using genetic algorithms. Codato and Fischetti (2006) introduces the application of combinatorial cuts for the approach, Fischetti et al. (2009) generates Benders cuts from a minimal infeasible system in the master problem and Bai and Rubin (2009) use advance features of CPLEX like callbacks to efficiently implement the approach by solving only one MIP master problem. Papadakos (2008) reports method to overcome numerical instability and Sherali and Fraticelli (2002) extend Benders approach to deal with integer subproblems.

Successful application of this approach for hub location problems is reported in de Camargo et al. (2008) and Gelareh and Nickel (2007).

Using Benders decomposition we split the problem to a master problem containing integer variables and a sub-problem, linking the two problems by a continues variable.

4.1. Master Problem

By decomposing the problem into an integer master problem and a linear programming subproblem we end up with a master problem whose solutions also include infeasible strings, as they are disconnected. In order to avoid a huge branch-and-bound tree with many infeasible incumbents having a disconnected hub-level network we instead introduce a master problem which only contains feasible solutions of the same master problem eliminating the disjoint strings therefore having tighter polytope.

In the network of this master problem a dummy node 0 sends one unit of flow to a set of hub nodes and as a result a directed circle is generated. Based on the length of this hub-level network the deployment decision is simultaneously made.

The figure is never cited

A mathematical formulation of the master a problem is presented in the following. We introduce the binary variables z_{ijk} which are 1 iff the flow from dummy node 0 to $k \in \mathcal{N}$ goes through arc $(i, j) : j \neq i$. z and y are now adapted to be indexed by $\mathcal{N}^0 = \mathcal{N} \cup \{0\}$.

Let $G(V, E)$ be a connected graph, where $V = \{1, 2, 3, \dots, n\}$ is the set of nodes or vertices and E the set of edges. Let $G_d = (V, A)$ be a directed graph derived from G , where $A = \{(i, j), (j, i) | (i, j) \in E\}$, that is, each edge u is associated with two arcs (i, j) and $(j, i) \in A$. Two new graphs $G^0 = (V_0, E_0)$ and $G_d^0 = (V_0, A_0)$ where $V_0 = V \cup \{0\}$, $E_0 = E \cup \{(0, j) | j \in V\}$, $A_0 = A \cup \{(0, j) | j \in V\}$, are defined.

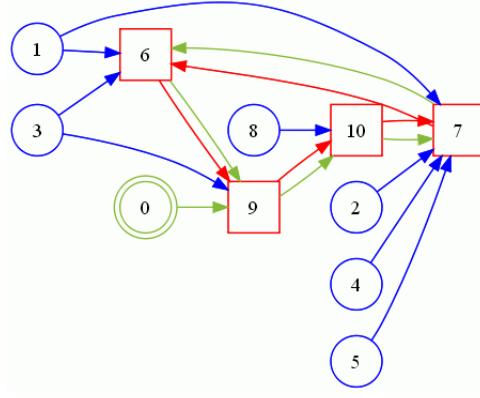

Figure 3: Master problem network: Hub nodes are indicated with squares (red) while spoke nodes are indicated with circles (blue). The dummy node (0) impose a directed cycle (green). The doubly drawn links (green) connect those nodes receiving flow from dummy node and making a directed string.

Let $\bar{Y} = (y_{ii})_{i \in V} \in \{0, 1\}^{|V|}$, $y = (y_u)_{u \in E_0} \in \{0, 1\}^{|E_0|}$ two 0 – 1 vectors, and $z_{ij}^k \geq 0$, $(i, j) \in A_0$, $k \in V'$, where V' is a subset of V , and z_{ij}^k is a real flow in the arc $(i, j) \in A_0$, having 0 as source and k as destination. $E(i)$ is considered as the set of edges $u \in E$ such that an endpoint is i , $\Gamma^+(i) = \{j | (i, j) \in A_0\}$ and $\Gamma^-(i) = \{j | (j, i) \in A_0\}$, $m = |E|$ and $n = |V|$ (Maculan et al., 2003).

Henceforward, we will refer to the following model as (MP)

$$\max - \sum_{k, l > k \in N} \sum_{v \in V} n_{vkl}^S c^v - \sum_{k, l \neq k \in N} \sum_{v \in V} n_{vkl}^H c^v + \eta \quad (45)$$

$$s.t. \sum_{j \in \Gamma^+(0)} z_{0j}^k - y_{kk} = 0, \quad k \in V, \quad (46)$$

$$\sum_{j \in \Gamma^+(i)} z_{ij}^k - \sum_{j \in \Gamma^-(i)} z_{ji}^k = 0, \quad i \in V - \{k\}, k \in V, \quad (47)$$

$$z_{ij}^k \leq y_{ij}, \quad \{i, j\} \in E_0, k \in V, \quad (48)$$

$$z_{ji}^k \leq y_{ij}, \quad \{i, j\} \in E_0, k \in V, \quad (49)$$

$$y_{ij} \leq x_i, \quad \{i, j\} \in E, \quad (50)$$

$$y_{ij} \leq x_j, \quad \{i, j\} \in E, \quad (51)$$

$$\sum_{j \in V} y_{0j} = 1, \quad i, j \in V, \quad (52)$$

$$\sum_{j \neq 0} z_{0jk} - y_{kk} = 0 \quad k \in V, \quad (53)$$

$$\sum_{j \neq k} z_{jkk} = y_{kk} \quad k \in V, \quad (54)$$

$$\sum_{j \neq i, k} z_{jik} \leq y_{ii}, \quad k, i \in V, \quad (55)$$

$$\mathcal{G}2, \mathcal{G}5, \mathcal{G}6, \mathcal{G}8, \mathcal{G}10, \mathcal{G}11, \quad (56)$$

$$\sum_v n_{vkl}^H \leq \sum_{k'l'} \sum_v t_{k'l'} V_{vk'l'}^H / \beta_1, \quad \forall k, l \neq k \in V, \quad (57)$$

$$\sum_v n_{vkl}^H \geq \sum_{k'l'} \sum_v t_{k'l'} V_{vk'l'}^H / \beta_2, \quad k, l \neq k \in V, \quad (58)$$

$$\sum_v n_v^H \leq \sum_{kl \neq k} t_{kl} y_{kl} / \beta_1, \quad (59)$$

$$\sum_v n_{vkl}^S \leq (s_{kl} + s_{lk}) \lceil t_{kl} / \beta_1 \rceil, \quad k, l \neq k \in V, \quad (60)$$

$$\sum_v n_{vkl}^S \geq (s_{kl} + s_{lk}) \lfloor t_{kl} / \beta_2 \rfloor, \quad k, l \neq k \in V, \quad (61)$$

$$z_{ij}^k \geq 0, \quad (i, j) \in A_0, k \in V, \quad (62)$$

$$y_{ij} \in \{0, 1\}, \{i, j\} \in E_0, h_k \in \{0, 1\}, k \in V, \eta \geq 0, \quad (63)$$

The linking variable $\eta \geq 0$, which links MP to the Benders cuts, should be explicitly bounded by some sufficiently big number such that the MP remains bounded.

The objective function (45) minimizes the total fixed cost for deployment and maximized the linking variable. Constraints (46) ensures that the dummy node sends one unit of flow to every selected hub node. Flow conservation for every intermediate hub node along any path from the dummy node to a particular destination holds (47). Flow traverses a link provided that it is a hub link and a hub links has its end-points as hub node (48)-(51). A dummy node is allocated to one and only one other hub node (52). The dummy node sends flow to a destination if and only if destination node is a hub. Constraints (53) stand for it. The flow from dummy node finally arrives at the destination hub node which is ensured by (54). Constraints (55) guaranty that intermediate nodes are actually hub nodes. The constraints $\mathcal{G}2 - \mathcal{G}10$ in (56) are the constraints from FDHSN. The rest of constraints (57-61) are constraints from practice where the number of vessels on each link is force to offer a regular frequency within the tolerance $[\beta_1, \beta_2]$ in (60). We have chosen half a day as tolerance, hence getting $\beta_1 = 6\frac{1}{2}$ and $\beta_2 = 7\frac{1}{2}$.

Typical Benders cuts are generated from the solution to the dual of the flow problem.

4.2. Branching Rules and Preprocessing

We exploit the structure of the model and employ some accelerating method to speed up MP resolution. We make use of explicit constraint branching to benefit from the hierarchy of decision in the overall process such that after some decisions have been made problem solves more efficiently. From among such decisions we can refer to the fact that it has been observed to be more efficient if the hub-level string and number of vessel type operating on the hub-level are determined before the branching take place on the remaining variables, the results are more promising.

In the master problem it has been observed that some variables can be fixed to zero and some symmetry can be broken to avoid exhaustive effort in branch-and-bound process.

4.2.1. Explicit Constraint Branching

Applegate et al. (2000) proposed a simple technique to explicitly branching on a set of variables rather than a single one. The idea is to divide the integer variables to different groups based on their decision impact on the rest of variables and set the total sum of variables in each group equal to a new integer variable. By giving different priorities in the branching promising numerical results is reported.

Here we divide the decisions on the number of vessel types on the hub-level in one group $(n_v^H, \forall v)$, number of vessels on links $(n_{vkl}^H, n_{vkl}^S, \forall v, k, l)$ in the second group and the decisions regarding allocations together with the hub-level network $(y_{kl}, \forall k, l, V_{vkl}^H, V_{vkl}^S, \forall v, k, l)$ in the third level. Then we introduce:

$$ECB_1 = \sum_v n_v^H, \quad (64)$$

$$ECB_2 = \sum_{vkl} (n_{vkl}^H + n_{vkl}^S), \quad (65)$$

$$ECB_3 = \sum_{k,l} y_{kl} + \sum_{vkl} (V_{vkl}^H + V_{vkl}^S). \quad (66)$$

and prioritize them by 1000, 500, 100 in branching, respectively. In practice when using CPLEX as MIP solver any positive integer can be used but we put enough gap between these three values for the cases where something between two consecutive priorities needs to be considered.

Due to the fact that there is at most one vessel type operating on any link we can also introduce the so called *Special Ordered Set of type 1 (SOS1)* in CPLEX such that branching takes place on the set of variables that at most one will have non-zero value. For example we can introduce $V_{vkl}^H, \forall v, k, l$ in one *SOS1*.

4.2.2. Preprocessing

Some of the design variables for the hub-level string can be fixed in the model.

$$y_{i0} = 0, \quad i, \quad (67)$$

$$z_{i0j} = 0, \quad i, j \neq i, \quad (68)$$

$$z_{ij0} = 0, \quad i, j \neq i \quad (69)$$

$$z_{iij} = 0, \quad i, j \neq i, \quad (70)$$

$$z_{iji} = 0, \quad i, j \neq i, \quad (71)$$

From Figure 4 one observes that there is no need to return any flow from string to the dummy node (67-69). There is not self-loop, from i to i link on the string (70). No flow departs from i and heads to $j \neq i$ if destined to i (71).

Preprocessing based on nature of business. When a link is longer than β (i.e. one week) it cannot be considered as a spoke link. Therefore we have

$$V_{vkl}^S = 0, \quad \text{if } t_{kl} \geq \beta \quad (72)$$

$$V_{vkl}^S = 0, \quad \text{if } t_{kl} \geq \beta. \quad (73)$$

and if a link is shorter than a day long it cannot be considered as a hub leg:

$$V_{vkl}^H = 0, \quad \text{if } t_{kl} \leq 1 \quad (74)$$

$$V_{vkl}^H = 0, \quad \text{if } t_{kl} \leq 1. \quad (75)$$

4.2.3. Tighter Benders Cuts

Whenever the subproblem is a flow problem, it is very likely that the problem is degenerate and the dual has multiple optimal solutions. Therefore there is a face of optimality which can be used to generate the cut from the solution to the dual. Some of these cuts might be dominated by others. Magnanti and Wong (1981) suggested a method for the best choice of the solution so that the resulting cut is a pareto cut and not dominated by any other cut.

However, it should be mentioned that making use of this approach might lead to instability in computation where the added equality constraint might lead to an infeasible tightening LP model. We overcome this difficulty in this way: Once the subproblem LP is solved we fix the dual values and ask the solver to move over the face of optimality and choose the optimal solution for the new objective which is suggested by Magnanti and Wong (1981).

In order to generate a relatively interior point to be used for the cut generation, we have adopted the following strategy: Let $\bar{x} = (\dots, y, \dots)$ be the current incumbent of branch-and-bound tree we set $\text{coef} = \max((\sum_{kl \neq k} t_{kl} y_{kl} - T^{\min}, \epsilon) / T^{\max} (\epsilon = 0.1))$ and introduce $x^\circ = \text{coef} \cdot \bar{x}$ as the relative interior point. By doing this we ensure that $T^{\min} < \sum_{kl \neq k} t_{kl} y_{kl}^\circ < T^{\max}$ in x° and the rest of variables are strictly within their feasible bounds.

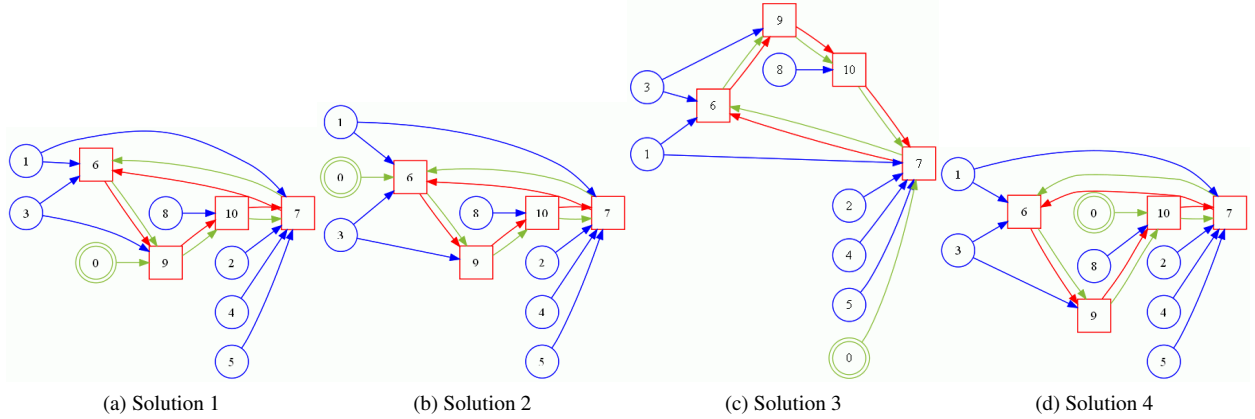

Figure 4: Multiple optimal solutions of MP.

4.2.4. Symmetry

By adding the dummy node in Section 4.1 the master problem experiences a symmetry which is related to the link connecting the dummy node to the main string. Figure 4 sheds more light on that.

Moreover, since every spoke node is allocated to at least one and at most N^{alloc} regardless of deployment therefor this also results in symmetry where two optimal solutions are only different in the number of spoke edges encompassed from a spoke node.

These two kind of symmetries can be broken by adding the following term to the objective function of MP.

$$- \sum_i M(i+1)y_{0i} - \sum_{i,j \neq i} s_{ij} \quad (76)$$

where M is a sufficiently large constant. The idea behind the big- M constraint is to distribute some unequal weights on the links to inject some level of perturbation and overcoming multiple optimal solutions. This value can be any thing but with enough big absolute values so that is not ignored when compared to the existing coefficients with respect to the order of magnitude.

The first term forces the dummy link being assigned to the hub node with smallest index and the last one ensures that unnecessary spoke links will not be established.

5. Computational Results

We consider a set of data instances composed of a subset of container terminals from North America (NA) and Europe (E). The sailing time of a single string E-NA is limited to be within 4 to 5 weeks as common for most liners. The factor of economy of scale α_v , $\forall v$ is chosen from the set $\{0.6, 0.8\}$, meaning that we expect the hub-network to be α_v times more expensive to operate than the spoke network. We solve 4 randomly generated instances for each $N = \{8, 9, 11, 12, 13, 14, 15\}$, where $n \in N$ is the number of ports. Our random instances are generated using a fleet of vessels with attributes reported in Table 1. The vessel capacities ('Capacity'), fixed deployment cost ('FxDep') and availabilities ('Avail') are reported in the first three columns, respectively. The cost is uniformly generated within given min and max values and is scaled with respect to the Euclidean distance for each potential link. The revenues are generated for every link and every vessel type for a percentage of the cost within the given min and max values. It must be noted that on some links the generated revenue might be negative (which is usually unavoidable due to the nature of business). Although speed can vary within a lower and upper bound, we assumed a fixed speed of 17 kn/m. and the travel times are calculated based on this speed. This allows the model to avoid deploying vessel on some of the spoke edges. The transshipment cost for each port is uniformly random generated in $[0, 5]$, which includes discharging, holding and reloading independent of vessel type (simplified assumption).



Figure 5: Spatial layout of ports between North-America and Europe.

All experiments have been run on an Intel Xeon CPU 2.66 GHz processor with 8 GB RAM. CPLEX callbacks have been used to implement the algorithm. In the computational experiments, a time limit of 10 hrs has been imposed.

Table 1: A hypothetical fleet attributes.

Vessel									
Capacity	FxDep	Avail	Cost		Revenue		Speed		
			Min	Max	Min	Max	Min	Max	
3000	100	40	20	50	-0.1	0.30	17	17	
4500	200	0	18	45	-0.05	0.35	17	17	
5000	300	20	16	40	0.00	0.40	17	17	
6500	400	0	14	35	0.00	0.45	17	17	
8000	500	10	12	30	0.00	0.50	17	17	

We have chosen the container terminals from a list of ports in the region. The North-American ports are only chosen from among those in the Eastern coast (see boxed region in Figure 5). For E-NA the ports are chosen from among those in Table 2. As shown in the table the first column indicates the index of port, the second column 'PORT' indicates the port name (some of the ports such as Rotterdam has more than one container terminal operated by different holders). The third column ('TERMINAL') concerns the terminal name and the next column ('HOLDING') indicates the port holder. The last three columns report the geographical information of each terminal.

Table 2: North-American and European container terminals.

CODE	PORT	TERMINAL	HOLDING	FACADE	LONG	LAT
1	Algeciras	Algeciras Terminal	APM	Europe	-5.44	36.14
2	Antwerp	Antwerp Gateway	DPW	Europe	0.26	51.31
3	Baltimore	APM Baltimore Terminal	APM	North America	-76.52	39.24
4	Los Angeles	APM Los Angeles Terminal	APM	North America	-118.25	33.73
5	Hampton Roads	APM Portsmouth Terminal	APM	North America	-76.32	36.86
6	Tocoma	APM Tacoma Terminal	APM	North America	-122.42	47.27
7	Miami	APM Terminals Miami	APM	North America	-80.16	25.77
8	New Orleans	APM Terminals New Orleans	APM	North America	-90.02	29.99
9	Oakland	APM Terminals Oakland	APM	North America	-122.32	37.81
10	Zeebrugge	APM Terminals Zeebrugge	APM	Europe	3.19	51.34
11	Arhus	Arhus Terminal	APM	Europe	10.25	56.15
12	Cagliari	Cagliari International Terminal	ERG	Europe	9.08	39.21
13	Vancouver	Centerm	DPW	North America	-123.08	49.29
14	Charleston	Charleston Terminal	APM	North America	-79.89	32.83
15	Antwerp	Churchill Terminal	PSA	Europe	4.38	51.28
16	Constanta	Constanta South Terminal	DPW	Europe	28.66	44.10
17	Constanta	Constanta Terminal	APM	Europe	28.65	44.15
18	Zeebrugge	Container Handling Zeebrugge	PSA	Europe	3.20	51.34
19	Livorno	Darsena Toscana Terminal	ERG	Europe	10.30	43.58
20	Antwerp	Delwaide Dock	DPW	Europe	4.33	51.33
21	Antwerp	Deurganck Terminal	PSA	Europe	4.27	51.29
22	Baltimore	Dundalk Marine Terminal	AIG	North America	-76.53	39.24
23	Rotterdam	ECT Delta Terminal	HPH	Europe	4.06	51.95
24	Rotterdam	ECT Hanno Terminal	HPH	Europe	4.43	51.89
25	Rotterdam	ECT Home Terminal	HPH	Europe	4.41	51.88
26	Bremerhaven	EUROGATE Terminal Bremerhaven	ERG	Europe	8.54	53.58
27	Hamburg	EUROGATE Terminal Hamburg	ERG	Europe	9.92	53.53
28	Antwerp	Europa Terminal	PSA	Europe	4.28	51.34
29	Fos	Fos - Darse 2	DPW	Europe	4.85	43.41
30	Savannah	Garden City Terminal	SSA	North America	-81.14	32.12
31	Gdynia	Gdynia Terminal	HPH	Europe	18.51	54.54
32	Harwich	Harwich International Port	HPH	Europe	1.26	51.95
34	Houston	Houston Terminal	APM	North America	-95.00	29.68
35	Jacksonville	Jacksonville Terminal	APM	North America	-81.54	30.39
36	La Spezia	La Spezia Terminal	ERG	Europe	9.85	44.11
37	Lisbon	LISCONT Operadores de Contentores	ERG	Europe	-9.11	38.72
38	Rotterdam	Maersk Delta	APM	Europe	4.06	51.95
39	Gioia Tauro	Medcenter Terminal I	APM	Europe	15.91	38.46
40	Gioia Tauro	Medcenter Terminal II	ERG	Europe	15.91	38.46
41	Marseille	Mourepiane	DPW	Europe	5.34	43.35
42	Antwerp	MSC Home Terminal	PSA	Europe	4.33	51.33
43	New Orleans	Napoleon Avenue Terminal	AIG	North America	-90.11	29.91
44	Zeebrugge	Noordelijk Insteek Terminal	PSA	Europe	3.22	51.33
45	Antwerp	Noordzee Terminal	PSA	Europe	4.27	51.35
46	Charleston	North Charleston Terminal	SSA	North America	-79.96	32.90
47	Bremerhaven	North Sea Terminal Bremerhaven	APM	Europe	8.54	53.58
48	Oakland	Oakland Terminal	HAN	North America	-122.32	37.80
49	Oakland	Oakland International Terminal	SSA	North America	-122.31	37.80
50	Long Beach	Pacific Terminal (PCT)	SSA	North America	-118.19	33.75
51	Tocoma	Pierce County Terminal	EVG	North America	-122.38	47.26
52	New York	Port Elizabeth Terminal	APM	North America	-74.15	40.66
53	Port Everglades	Port Everglades Terminal	APM	North America	-80.12	26.07
54	New York	Port Newark Terminal	AIG	North America	-74.15	40.69
55	Felixstowe	Port of Felixstowe	HPH	Europe	1.30	51.96
56	Miami	Port of Miami Terminal Operating Company	AIG	North America	-80.16	25.77
57	Le Havre	Quai de l'Europe	DPW	Europe	0.18	49.48
58	Le Havre	Quai des Ameriques	DPW	Europe	0.17	49.47
59	Ravenna	Ravenna Terminal	ERG	Europe	12.25	44.45
60	Salerno	Salerno Terminal	ERG	Europe	14.74	40.67
61	Savannah	Savannah Terminal	APM	North America	-81.14	32.13
62	Baltimore	Seagirt Marine Terminal	AIG	North America	-76.54	39.26
63	Los Angeles	Seaside Terminal	EVG	North America	-118.27	33.74
64	Sines	Sines Terminal	PSA	Europe	-8.85	37.94
65	Southampton	Southampton Terminals	DPW	Europe	-1.45	50.91
66	Jacksonville	Talleyrand Marine Terminal	SSA	North America	-81.62	30.35
67	Taranto	Taranto Terminal	EVG	Europe	17.16	40.50
67	Seattle	Terminal 18	SSA	North America	-122.35	47.58
69	Seattle	Terminal 25	SSA	North America	-122.34	47.58
70	Seattle	Terminal 46	HAN	North America	-122.34	47.60
71	Long Beach	Terminal A	SSA	North America	-118.24	33.77
72	Long Beach	Terminal C60	SSA	North America	-118.22	33.77
73	Thamesport	Thamesport	HPH	Europe	0.68	51.43
74	London	Tilbury Container Services	DPW	Europe	0.34	51.47
75	Philadelphia	Tioga Marine Terminal	AIG	North America	-75.09	39.98
76	Long Beach	Total Terminals International	HAN	North America	-118.24	33.75
77	Trieste	Trieste Maritime Terminal	EVG	Europe	13.76	45.63
78	Venice	Venice Terminal	PSA	Europe	12.25	45.45
79	Genoa	Voltri Terminal Europa	PSA	Europe	8.79	44.42
80	Charleston	Wando Welch Terminal	SSA	North America	-79.89	32.83
81	Jacksonville	Blount Island Terminal	SSA	North America	-81.54	30.40
82	Charleston	Columbus Street Terminal	SSA	North America	-79.93	32.79
83	Tampa	Garrison, FL	SSA	North America	-82.43	27.92
84	Houston	Houston	SSA	North America	-95.28	29.74
85	Oakland	Howard Terminal	SSA	North America	-122.29	37.80
86	Mobile, AL	Mobile	SSA	North America	-88.04	30.70
87	Morehead City	Morehead City	SSA	North America	-76.70	34.72
88	Savannah	Ocean Terminal	SSA	North America	-81.10	32.09
89	Panama City, FL	Panama City, FL	SSA	North America	-85.73	30.18
90	Pensacola, FL	Pensacola, FL	SSA	North America	-87.21	30.40
91	Gulfport, MS	Port of Gulfport	SSA	North America	-89.09	30.36
92	Charleston	Union Pier Terminal	SSA	North America	-79.92	32.78
93	Vancouver, WA	Vancouver, WA	SSA	North America	-122.70	45.63
94	Wilmington	Wilmington	SSA	North America	-77.95	34.19

Every instance is generated by randomly choosing n container terminals from Table 2. For confidentiality reasons we have generated the flow demands randomly.

In Table 3 we report the numerical results on instances of the problem with the aforementioned parameters. Whenever the problem is not solved to optimality the reported gap is inserted. For a given value of α and n , four rows corresponding to all four instances are reported¹. If an instance was infeasible we omitted it in the table. This is for example the case for the first instance of the table $n = 8$ with $\alpha = 0.8, 0.6$. The top most part of the table starts by $n = 8$ and will be followed by $n = 9, \dots, 15$.

¹GIS shape files, flow data files and xy coordinate file can be supplied upon request from corresponding author

Table 3: North-American and European container terminals.

	instance	str. Len.	(vesType)Nr.	time (sec.)	status/gap	nr. nodes
N=8						
$\alpha=0.8$	NA-E.8(2)	29.62	(0) 4	236.55	opt	241
	NA-E.8(3)	29.62	(0) 4	232.66	opt	241
	NA-E.8(4)	29.62	(0) 4	236.03	opt	241
$\alpha=0.6$	NA-E.8(2)	29.5807	(0) 4	385.86	opt	261
	NA-E.8(3)	29.5807	(0) 4	379.21	opt	261
	NA-E.8(4)	29.5807	(0) 4	382.74	opt	261
N=9						
$\alpha=0.8$	NA-E.9(1)	33.635	(0) 4	23141.2	opt	721
	NA-E.9(2)	30.0866	(0) 4	14118	opt	1141
	NA-E.9(3)	30.0866	(0) 4	14028.7	opt	1141
	NA-E.9(4)	30.0866	(0) 4	13912.2	opt	1141
$\alpha=0.6$	NA-E.9(1)	29.2858	(0) 4	22266.3	opt	701
	NA-E.9(2)	31.3843	(1) 3	4814.74	opt	741
	NA-E.9(3)	31.3843	(1) 3	4832.29	opt	741
	NA-E.9(4)	31.3843	(1) 3	4806.41	opt	741
N=10						
$\alpha=0.8$	NA-E.10(1)	29.4819	(0) 4	10249.3	opt	662
	NA-E.10(2)	29.4819	(0) 4	10195.4	opt	662
	NA-E.10(3)	30.4915	(0) 4	1760.68	opt	502
$\alpha=0.6$	NA-E.10(4)	29.4819	(0) 4	10255.7	opt	662
	NA-E.10(1)	29.4819	(0) 4	21880.5	opt	862
	NA-E.10(2)	29.4819	(0) 4	21707.9	opt	862
	NA-E.10(3)	30.4915	(0) 4	1841.24	opt	502
NA-E.10(4)	29.4819	(0) 4	21993.8	opt	862	
N=11						
$\alpha=0.8$	NA-E.11(1)	28.0041	(1) 4	21731.8	39.275	582
	NA-E.11(2)	28.0841	(0) 4	22844.3	38.217	602
	NA-E.11(3)	28.0041	(1) 4	21780.2	39.275	582
	NA-E.11(4)	28.0041	(1) 4	21604.5	38.217	592
$\alpha=0.6$	NA-E.11(1)	28.3738	(0) 4	23034.3	36.285	582
	NA-E.11(2)	28.3994	(0) 4	21603.7	36.285	581
	NA-E.11(3)	28.3738	(0) 4	23110.6	36.285	582
	NA-E.11(4)	28.3738	(0) 4	22713.4	36.285	582
N=12						
$\alpha=0.8$	NA-E.12(1)	33.3176	(0) 4	21604.5	129.39	311
	NA-E.12(3)	28.4769	(0) 4	23175.5	178.57	362
	NA-E.12(2)	33.3176	(0) 4	21628.9	129.39	308
	NA-E.12(4)	30.1284	(1) 4	23435.7	109.95	362
$\alpha=0.6$	NA-E.12(1)	30.7944	(0) 4	21653.7	158.43	322
	NA-E.12(2)	30.7944	(0) 4	21602	154.89	326
	NA-E.12(3)	28.2805	(0) 4	21641	176.56	342
	NA-E.12(4)	30.2747	(0) 4	22578.6	121.58	322
N=13						
$\alpha=0.8$	NA-E.13(1)	30.9899	(0) 4	22410.1	229.32	221
	NA-E.13(2)	31.6604	(0) 4	23879.8	230.81	242
	NA-E.13(3)	30.9899	(0) 4	22872.5	229.32	221
	NA-E.13(4)	30.9899	(0) 4	22535	229.32	221
$\alpha=0.6$	NA-E.13(1)	29.693	(0) 4	22124.2	291.26	241
	NA-E.13(2)	31.5716	(0) 4	21853.5	196.12	242
	NA-E.13(3)	29.693	(0) 4	22888.6	291.26	241
	NA-E.13(4)	29.693	(0) 4	22137.1	291.26	241
N=14						
$\alpha=0.8$	NA-E.14(1)	34.8491	(0) 4	21671.2	827.51	42
	NA-E.14(2)	34.8491	(0) 4	21611.9	827.51	42
	NA-E.14(3)	34.8491	(0) 4	21602.8	714.54	45
	NA-E.14(4)	34.8491	(0) 4	21888.3	827.51	42
$\alpha=0.6$	NA-E.14(1)	29.088	(2) 4	28108.2	∞	2
	NA-E.14(2)	29.088	(2) 4	27927.5	∞	2
	NA-E.14(3)	29.088	(2) 4	28038.5	∞	2
	NA-E.14(4)	29.088	(2) 4	27838.3	∞	2
N=15						
$\alpha=0.8$	NA-E.15(1)	33.3813	(2) 4	21647.8	∞	2
	NA-E.15(2)	31.0443	(2) 4	30587.2	∞	2
	NA-E.15(3)	33.2535	(0) 4	21696.2	868.36	30
	NA-E.15(4)	30.2214	(2) 4	25122.2	∞	2
$\alpha=0.6$	NA-E.15(1)	33.3813	(2) 4	22299	∞	2
	NA-E.15(2)	30.6159	(2) 4	25691.9	∞	2
	NA-E.15(3)	33.3312	(0) 4	21691	840.78	37
	NA-E.15(4)	30.6531	(2) 4	32503.3	∞	2

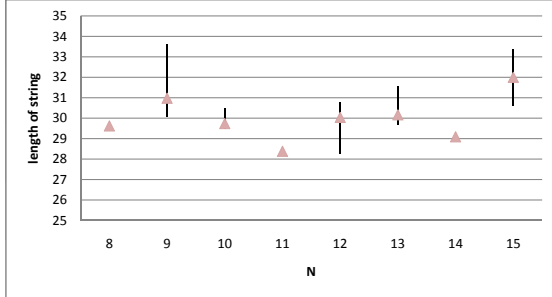

(a) $\alpha = 0.6$

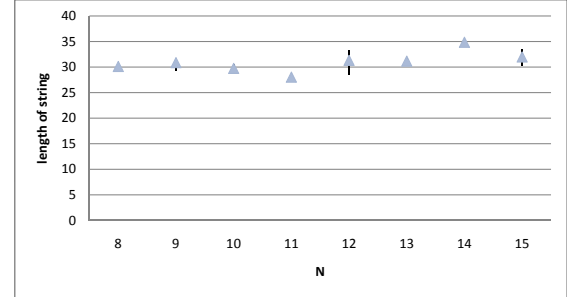

(b) $\alpha = 0.8$

Figure 6: Distribution of string Length.

Before interpreting the results, it should be noted that because of the high degeneracy in the flow sub-problem and due to multiple optimal solutions to the master problem, the optimal solution to the Benders approach has often been found much earlier than the approach converges. Therefore, for larger instances where the gaps are large it is not clear if the solution is optimal, and therefore in the following discussion we assume that the solution is 'good enough' and allows a valid discussion.

In Table 3 as mentioned earlier we requested the string duration to be between 28 and 35 days. As the table shows, the upper bound is almost never reached. Figure 6 shows that the general tendency is to increase the duration of a string as n increases, but the duration never hits the upper bound. This behavior is commonly observed in the table for both values of α_v , having some irregularities for $\alpha_v = 0.6$ and $n = 12, 14$.

As the fourth column ('vesType)Nr.') shows a four-week length rotation is proposed almost always, even if the string is considered to be of longer length. In practice the LSPs have this flexibility to adjust the speed and reduce the string length to 28. However, there is one case for $n = 9, \alpha = 0.6$ which suggest making use of three vessels of smaller size. In such case the LSP has to speed up the vessels and reduce the length of string to 21 days. At the bottom of the table it is observed that when n increases there is a tendency towards using smaller vessels but deploying 4 vessels.

Regarding computational time (bounded by the time limit), as depicted in Figure 7 a dramatic increase can be observed. This indicates the complexity of the studied problem.

If optimality is proven within the time limit we indicate it by 'opt' in the column ('status/gap'). If the gap is over 1000 percent we report ∞ and the decomposition is viewed as a heuristic with no bound on the solution quality.

The last column indicates the number of cuts separated and added to the Benders master problem or equivalently the number of incumbent nodes processed by the branch-and-bound tree of the master problem.

6. Summary, conclusion and outlook to future work

This work deals with a simultaneous fleet deployment and network design for regional planning of liner service providers. It is particularly tailored for the single rotation regional planning. To the best of our knowledge, it is the first model considering this problem. The model offers considerable flexibility for incorporating additional constraints met in practice. A unique feature of this simultaneous deployment-network design model is the flexibility of demand which, to the best of our knowledge, is not previously addressed in the literature on applications. We proposed a primal decomposition approach to solve instances of the problem which are extremely challenging for the existing state-of-the-art solvers. The approach was implemented in a branch-and-cut scheme making efficient use of the

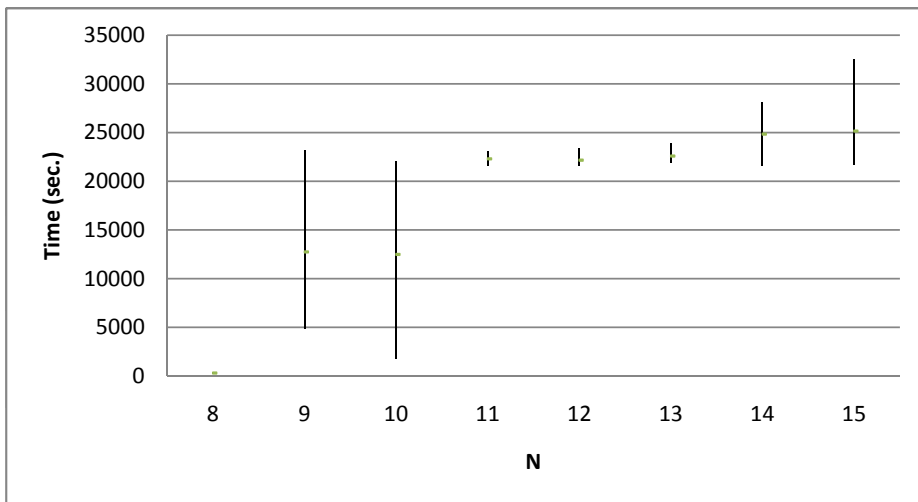

Figure 7: Growth of the computational time as function of the number of nodes n

modern features of CPLEX while taking into account the latest enhancements to the efficiency of Benders method. Several branching rules, preprocessing and symmetry breaking rules have been introduced to improve the efficiency.

Our computational results indicate that the larger vessels are better candidates for deployment in a E-NA region. The number of required vessel on a string does not exceed 4 vessels. Adjustments can be made to the speed such that every rotation becomes exactly 4 weeks to ensure a weekly departure.

In the future we will extend the model to consider a global design of network which simultaneously suggests deployment and string designs for different regions. We will also concentrate on metaheuristics and Lagrangian relaxation for solving instances of the problem. We try to project the formulation to a lower dimension and investigate some exact approaches such as branch-and-cut to solve instances of the problem.

7. Acknowledgment

The authors would like to thank The Danish Council for Strategic Research, The Programme Commission on Strategic Growth Technologies, for their support to the ENERPLAN project.

References

- Alizadeh, A. H., Nomikos, N. K., 2007. Investment timing and trading strategies in the sale and purchase market for ships. *Transportation Research Part B: Methodological* 41(1), 126–143.
- Alumur, S., Kara, B. Y., 2008. Network hub location problems: The state of the art. *European Journal of Operational Research* 190 (1), 1–21.
- Appleget, J., Wood, R., RESEARCH, N. P. S. M. C. D. O. O., 2000. Explicit-constraint branching for solving mixed-integer programs. *Computing tools for modeling, optimization, and simulation: interfaces in computer science and operations research*, 245.
- Aversa, R., Botter, H., Haralambides, R., Yoshizaki, H., 2005. A mixed integer programming model on the location of a hub port in the east coast of south america. *Maritime Economics and Logistics* 7, 1–18.
- Bai, L., Rubin, P., 2009. Combinatorial Benders Cuts for the Minimum Tollbooth Problem. *Operations research* 57 (6), 1510–1522.
- Benders, J., 2005. Partitioning procedures for solving mixed-variables programming problems. *Computational Management Science* 2 (1), 3–19.
- Bradley, S. P., Hax, A. C., Magnanti, T. L., 1977. *Applied Mathematical Programming*. Addison-Wesley.
- Bremer, W. M., Perakis, A., 1992. An operational tanker scheduling optimization system: Model implementation, results and possible extension. *Maritime Policy & Management* 19(3), 189–199.
- Brønmo, G., Christiansen, M., Fagerholt, K., Nygreen, B., 2007. A multi-start local search heuristic for ship scheduling - a computational study. *Computers & Operations Research* 34, 900–917.
- Cho, S.-C., Perakis, A., 1996. Optimal liner fleet routing strategies. *Special Issue of Maritime Policy and Management* 23(3), 249–259.
- Cho, S. C., Perakis, A. N., 2001. An improved formulation for bulk cargo ship scheduling with a single loading port. *Maritime Policy & Management* 28:4, 339–345.
- Choong, S., Cole, M., Kutanoglu, E., 2002. Empty container management for intermodal transportation networks. *Transportation Research Part E* 38 (6), 423–438.
- Christiansen, M., Fagerholt, K., Ronen, D., 2004. Ship routing and scheduling: Status and prespective. *Transportation Science* 38(1), 1–18.
- Christiansen, M., Ronen, D., Nygreen, B., Fagerholt, K., 2007. *Maritime transportation*. Handbooks in Operations Research and Management Sciences 14, 189–284.
- Codato, G., Fischetti, M., 2006. Combinatorial Benders' cuts for mixed-integer linear programming. *OPERATIONS RESEARCH-BALTIMORE THEN LINTHICUM-* 54 (4), 756.
- de Camargo, R., Miranda Jr, G., Luna, H., 2008. Benders decomposition for the uncapacitated multiple allocation hub location problem. *Computers & Operations Research* 35 (4), 1047–1064.
- Everett, J., Hax, A., Lewison, V., Nutts, D., 1972. Optimization of a fleet of large tankers and bulkers: A linear programming approach. *Marine Technology*.
- Fischetti, M., Salvagnin, D., Zanette, A., 2009. Minimal infeasible subsystems and Benders cuts. *Mathematical Programming* to appear.
- Gelareh, S., Meng, Q., 2010. A novel modeling approach for the fleet deployment problem within a short-term planning horizon. *Transportation Research Part E: Logistics and Transportation Review* 46 (1), 76 – 89.
URL <http://www.sciencedirect.com/science/article/B6VHF-4WSG2YN-1/2/ca9ecdda45c27948d92d0deca9fdb64b>
- Gelareh, S., Nickel, S., 2007. A benders decomposition for hub location problems arising in public transport. In: *Proceeding of GOR2007*.
- Gelareh, S., Nickel, S., Pisinger, D., 2010. Liner shipping hub network design in a competitive environment. *Transportation Research Part E: Logistics and Transportation Review* In Press, Corrected Proof, –.
- Hoff, A., Lium, A.-G., Løkketangen, A., Crainic, T., 2009. A metaheuristic for stochastic service network design. *Journal of Heuristics*.
- Hsu, C. ., Hsieh, Y. ., 2007. Routing, ship size, and sailing frequency decision-making for a maritime hub-and-spoke container network. *Mathematical and Computer Modelling* 45 (7-8), 899–916.
- Imai, A., Nishimura, E., Papadimitriou, S., Liu, M., 2006. The economic viability of container mega-ships. *Transportation Research Part E* 42 (1), 21–41.
- Imai, A., Shintani, K., Papadimitriou, S., 2009. Multi-port vs. Hub-and-Spoke port calls by containerships. *Transportation Research Part E*.
- ISL, 2008. *Shipping Statistics and market Review*. Vol. 52. ISL institute of shipping economics and logistics.
- Jaramillo, D., Perakis, A., 1991. Fleet deployment optimization for liner shipping - part 2. implementation and results. *Maritime Policy and Management* 18 (4), 235–262.

A mixed integer linear programming formulation is proposed for the simultaneous design of network and fleet deployment of a liner shipping company for deep-sea shipping. The underlying network design problem is based on a 4-index (5-index by considering capacity type) formulation of the hub location problem which are known for their tightness. The demand is considered to be elastic in the sense that the service provider can accept any fraction of the origin-destination demand. We then propose a primal decomposition method to solve instances of the problem to optimality. Numerical results confirm superiority of our approach in comparison with a general-purpose mixed integer programming solver.

ISBN 978-87-90855-91-8

DTU Management Engineering
Department of Management Engineering
Technical University of Denmark

Produktionstorvet
Building 424
DK-2800 Kongens Lyngby
Denmark
Tel. +45 45 25 48 00
Fax +45 45 93 34 35

www.man.dtu.dk

- Kim, S. H., Lee, K. K., 1997. An optimization-based decision support system for ship scheduling. *Computers & Industrial Engineering* 33 (3-4), 689–692.
- Konings, R., 2006. Hub-and-spoke networks in container-on-barge transport. No. 1963.
- Korsvik, J. E., Fagerholt, K., 2008. A tabu search heuristic for ship routing and scheduling with flexible cargo quantities. *Journal of Heuristics*, 1–21 Article in Press.
- Løfstedt, B., Pisinger, D., Spoorendonk, S., 2010. Liner shipping cargo allocation with repositioning of empty containers. submitted.
- Lium, A.-G., Crainic, T., Wallace, S., 2009. A study of demand stochasticity in service network design. *Transportation Science* 43 (2), 144–157.
- Maculan, N., Plateau, G., Lisser, A., 01 2003. Integer linear models with a polynomial number of variables and constraints for some classical combinatorial optimization problems. *Pesquisa Operacional* 23(1), 161 – 168.
- Magnanti, T., Mireault, P., Wong, R., 1986. Tailoring Benders decomposition for uncapacitated network design. *Netflow at Pisa*, 112–154.
- Magnanti, T., Wong, R., 1981. Accelerating Benders decomposition: Algorithmic enhancement and model selection criteria. *Operations Research* 29 (3), 464–484.
- O'Kelly, M., 1987. A quadratic integer program for the location of interacting hub facilities. *European Journal of Operational Research* 32, 393–404.
- Papadakis, N. A., Perakis, A. N., 1989. A nonlinear approach to the multiorigin, multideestination fleet deployment problem. *Naval Research Logistics* 36 (4), 515–528.
- Papadakis, N., 2008. Practical enhancements to the Magnanti-Wong method. *Operations Research Letters* 36 (4), 444–449.
- Perakis, A., 2002. Fleet operation optimisation and fleet deployment. LLP, Ch. 26, pp. 580–597.
- Perakis, A., Bremer, W., 1992. An operational tanker scheduling optimization system: Background, current practice and model formulation. *Maritime Policy & Management* 19(3), 177–187.
- Perakis, A., Jaramillo, D., 1991. Fleet deployment optimization for liner shipping - part 1. background, problem formulation and solution approaches. *Maritime Policy and Management* 18 (3), 183–200.
- Perakis, A., Papadakis, N., 1987a. Fleet deployment optimization models, part i. *Maritime Policy and Management* XIV(2), 127–144.
- Perakis, A. N., Papadakis, N. A., 1987b. Fleet deployment optimization models, part ii. *Maritime Policy and Management* XIV(2), 145 – 155.
- Poojari, C., Beasley, J., 2009. Improving benders decomposition using a genetic algorithm. *European Journal of Operational Research* 199 (1), 89–97.
- Powell, B. J., Perakis, A. N., 1997. Fleet deployment optimization for liner shipping: an integer programming model. *Maritime Policy and Management* 24 (2), 183–192.
- Reddy, P., Karimi, I., Srinivasan, R., 2004. A new continuous-time formulation for scheduling crude oil operations. *Chemical Engineering Science* 59, 1325–1341.
- Reinhardt, L. B., Kallehauge, B., Pisinger, D., 2010. A branch and cut algorithm for the container shipping network design problem. submitted.
- Ronen, D., 1983. Cargo ships routing and scheduling: Survey of models and problems. *European Journal of Operational Research* 12, 119–126.
- Ronen, D., 1993. Ship scheduling: The last decade. *European Journal of Operational Research* 71, 325–333.
- Ronen, D., Fagerholt, K., Christiansen, M., 2004. Ship routing and scheduling: Status and perspectives. *Transportation Science* 38 (1), 1–18.
- Sherali, H., Fraticelli, B., 2002. A modification of Benders' decomposition algorithm for discrete subproblems: An approach for stochastic programs with integer recourse. *Journal of Global Optimization* 22 (1), 319–342.
- Shintani, K., Imai, A., Nishimura, E., Papadimitriou, S., January 2007. The container shipping network design problem with empty container repositioning. *Transportation Research Part E* 43 (1), 39–59.
- Takano, K., Arai, M., 2008. A genetic algorithm for the hub-and-spoke problem applied to containerized cargo transport. *Journal of Marine Science and Technology*.
- UNCTAD (Ed.), 2008. Review Of Maritime Transport 2008. United Nations Conference on Trade and Development (UNCTAD) Geneva and New York.