

Technical University of Denmark



A 2-10 GHz GaAs MMIC opto-electronic phase detector for optical microwave signal generators

Bruun, Marlene; Gliese, Ulrik Bo; Petersen, Anders Kongstad; Nielsen, Torben Nørskov; Stubkjær, Kristian

Published in:

I E E E - M T T S International Microwave Symposium. Digest

Link to article, DOI:

[10.1109/MWSYM.1994.335443](https://doi.org/10.1109/MWSYM.1994.335443)

Publication date:

1994

Document Version

Publisher's PDF, also known as Version of record

[Link back to DTU Orbit](#)

Citation (APA):

Bruun, M., Gliese, U. B., Petersen, A. K., Nielsen, T. N., & Stubkjær, K. (1994). A 2-10 GHz GaAs MMIC opto-electronic phase detector for optical microwave signal generators. I E E E - M T T S International Microwave Symposium. Digest, 1, 499-502. DOI: 10.1109/MWSYM.1994.335443

DTU Library

Technical Information Center of Denmark

General rights

Copyright and moral rights for the publications made accessible in the public portal are retained by the authors and/or other copyright owners and it is a condition of accessing publications that users recognise and abide by the legal requirements associated with these rights.

- Users may download and print one copy of any publication from the public portal for the purpose of private study or research.
- You may not further distribute the material or use it for any profit-making activity or commercial gain
- You may freely distribute the URL identifying the publication in the public portal

If you believe that this document breaches copyright please contact us providing details, and we will remove access to the work immediately and investigate your claim.

A 2-10 GHz GaAs MMIC Opto-Electronic Phase Detector for Optical Microwave Signal Generators

M. Bruun, U. Gliese, A.K. Petersen, T.N. Nielsen and K.E. Stubkjær

Center for Broadband Telecommunications, Electromagnetics Institute
Technical University of Denmark, Building 348, DK-2800 Lyngby, Denmark

Abstract

Optical transmission of microwave signals becomes increasingly important. Techniques using beat between optical carriers of semiconductor lasers are promising if efficient optical phase locked loops are realized. A highly efficient GaAs MMIC opto-electronic phase detector for a 2-10 GHz OPLL is reported.

Introduction

Efficient techniques for optical generation of microwave signals with high spectral purity are subject to much interest because of the potential of optical microwave links. A most promising method is to utilize the beat signal between the optical

carriers of wideband optical phase locked semiconductor lasers [1]-[4]. The use of semiconductor lasers as opposed to solid state lasers, such as Nd:YAG, is attractive due to their compactness and potential for monolithic opto-electronic integration. In this paper we present the results on a monolithic microwave integration of the opto-electronic (O/E) phase detector, which is one of the essential parts of optical phase locked loops (OPLLs). This is, to the best of our knowledge, the first report on integration of this type of circuit.

Phase Detector Function

As shown in Fig. 1, the OPLL microwave signal generator [4] consists of a free running transmitter

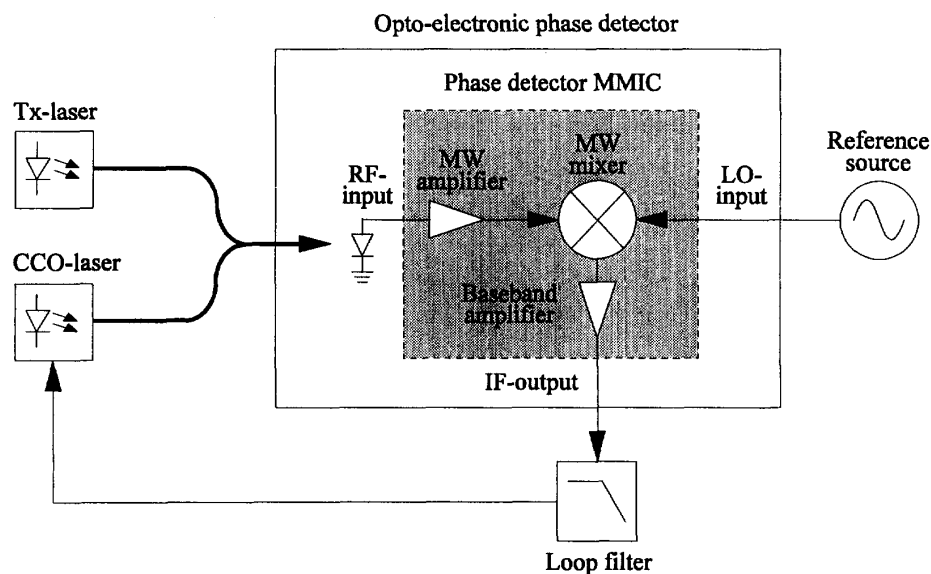

Figure 1: Schematic of the optical phase locked loop with a functional diagram for the opto-electronic phase detector MMIC.

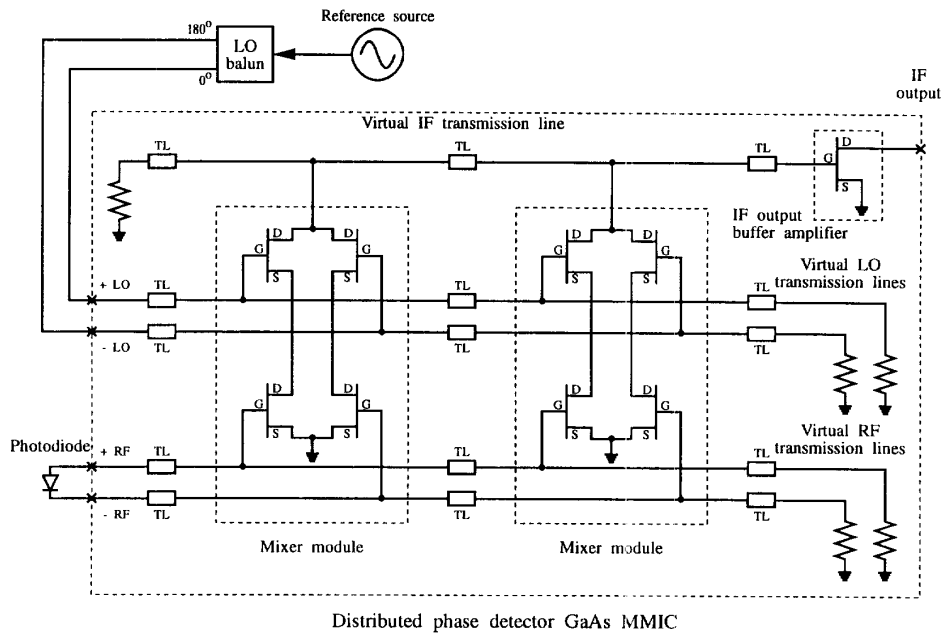

Figure 2: Diagram of the GaAs MMIC based O/E phase detector.

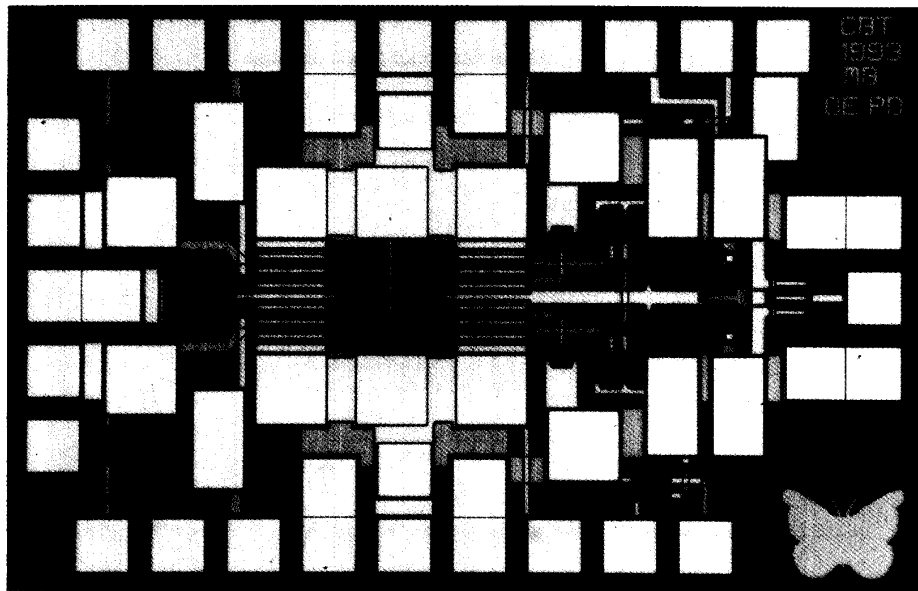

Figure 3: Photo of the phase detector GaAs MMIC having the physical dimensions of 1.1×1.7 mm.

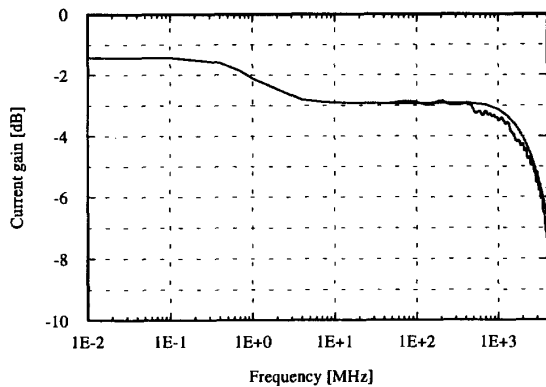

Figure 4: Current gain of the phase detector MMIC as a function of the output error signal frequency. Simulated: Smooth curve, Measured: Rippled curve. $f_{LO} = 8$ GHz, $P_{RF} = -35$ dBm and $P_{LO} = 15$ dBm.

laser (Tx-laser), an O/E phase detector, a loop filter and a Current Controlled Oscillator laser (CCO-laser). The microwave signal that is generated by the beat of two semiconductor lasers is compared to the signal from a microwave reference source having low phase noise. The resulting phase error signal is then fed back to the CCO-laser which is forced to track the Tx-laser. This causes a significant reduction of the phase noise of the beat signal within the loop bandwidth, thereby generating an optical microwave signal with very high spectral purity [4].

The O/E phase detector measures the phase difference between two optical signals and a microwave signal as shown in Fig. 1. Functionally, it performs coherent photo-mixing followed by microwave amplification, microwave mixing and, finally, baseband amplification. The electronic parts are implemented as a GaAs monolithic microwave integrated circuit (MMIC). This is the first step towards integration of the OPLL, and it results in reduced RF-IF time delay compared to a previous bulk implementation [4]. This is essential for wideband loop operation [2].

MMIC Design and Layout

A diagram of the GaAs MMIC based O/E phase detector is shown in Fig. 2. A distributed design has been chosen to increase the overall gain and bandwidth. Double balanced signals are applied at

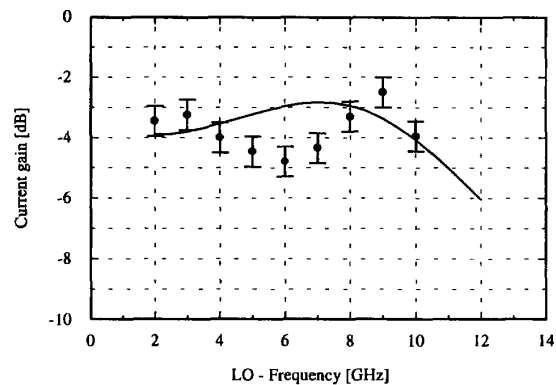

Figure 5: Input bandwidth of the phase detector MMIC in terms of current gain variation. Simulated: Smooth curve, Measured: Dots and error bars. $f_{RF} = f_{LO} \pm 100$ MHz, $P_{RF} = -35$ dBm and $P_{LO} = -35$ dBm.

both the RF- and LO-inputs. An external balun is used to generate the balanced LO-signal, whereas the balanced RF-signal is readily obtained using both photodiode terminals; this significantly reduces the RF-IF time delay.

For the two mixer modules, a low noise dual gate FET mixer configuration has been applied. The upper two FETs of the mixer modules are biased in their saturated region so, that they convert the LO-signal variation to a V_{ds} variation at the lower FET pairs. The bias of the two lower FETs is selected for operation in the knee of the $I_{ds}-V_{ds}$ characteristic. Consequently, the RF-signal will experience both a g_m and r_{ds} variation in phase with the LO-signal, thus mixing the two signals. Finally, the resulting IF-signal is amplified in the upper FET pairs.

The IF-signals from the drain outputs of the mixer modules add in phase along the virtual IF transmission line and the resulting IF-signal is, finally, amplified by the IF output buffer amplifier. This buffer further provides a high impedance current generator output which is required to optimally drive the CCO-laser of the OPLL.

The symmetrical implementation of the MMIC, as seen from the photo in Fig. 3, has been chosen to maintain the best possible balance of the RF and LO signals. The two mixer modules are seen as the two identical sets of structures in the center of the chip. To minimize the physical size, and thereby the time delay, the incoming transmission lines are connected

to one side of the FET's gate fingers and the continuation of the transmission lines are carried on from the opposite side of the same gate fingers. This technique also applies to the IF transmission line.

Performance

For the O/E phase detector, the main parameter is the current gain defined as output current injected into the CCO-laser relative to the input RF-current as generated in the photodiode. The implemented phase detector MMIC has been characterized using on-wafer probing. A current gain of -1.5 dB with a 3 dB bandwidth of 2 GHz has been obtained as shown in Fig. 4. This enables application in OPLLs with loop bandwidths of up to 200 MHz [2]. Excellent symmetry with respect to RF<LO and RF>LO mixing is measured, and the RF-IF time delay has been estimated to 30 ps, which is low compared to the previous bulk implementation with a time delay of around 150 ps.

The simulated and measured input bandwidth of the device is shown in Fig. 5 for a fixed offset of 100 MHz between the RF- and LO-signals. Allowing a 1 dB variation to ensure low phase variation, an input bandwidth of 2-10 GHz is obtained. This secures the microwave signal tunability of the OPLL.

Finally, the damping of higher harmonics is better than 30 dB, the spurious responses are lower

than -70 dB and the intermodulation products are lower than -50 dB at the desired RF-signal level.

Conclusion

In conclusion, we have presented results on the first integration of an O/E phase detector. The results demonstrate that the O/E phase detector of wideband OPLLs can be integrated using GaAs MMIC technology yielding a significant performance improvement as compared to non-integrated versions. This represents the first step toward the complete monolithic opto-electronic integration of semiconductor laser OPLLs.

Acknowledgements

Part of this work was carried out under ESA, ESTEC contract 122250, and the MMIC was processed through the EuroChip Program.

References

- [1] M. Kouroggi et. al.: *Photonics Technology Letters*, Vol. 3, No. 3, 1991, pp. 270-272.
- [2] U. Gliese et. al.: *Journal of Lightwave Technology*, Vol. 9, No. 6, 1991, pp. 779-790.
- [3] R.T. Ramos et. al.: *Electronics Letters*, Vol. 28, No. 1, 1992, pp. 82-83.
- [4] U. Gliese et. al.: *Photonics Technology Letters*, Vol. 4, No. 8, 1992, pp. 936-938.