

Technical University of Denmark



Reduction of dispersive ground-roll using time delay spectrometry

Kjeldsen, Peter Møller; Larsen, Henrik C

Published in:

I E E International Conference on Acoustics, Speech and Signal Processing. Proceedings

Link to article, DOI:

[10.1109/ICASSP.1992.226266](https://doi.org/10.1109/ICASSP.1992.226266)

Publication date:

1992

Document Version

Publisher's PDF, also known as Version of record

[Link back to DTU Orbit](#)

Citation (APA):

Kjeldsen, P. M., & Larsen, H. C. (1992). Reduction of dispersive ground-roll using time delay spectrometry. I E E International Conference on Acoustics, Speech and Signal Processing. Proceedings, 2, 101-104. DOI: [10.1109/ICASSP.1992.226266](https://doi.org/10.1109/ICASSP.1992.226266)

DTU Library

Technical Information Center of Denmark

General rights

Copyright and moral rights for the publications made accessible in the public portal are retained by the authors and/or other copyright owners and it is a condition of accessing publications that users recognise and abide by the legal requirements associated with these rights.

- Users may download and print one copy of any publication from the public portal for the purpose of private study or research.
- You may not further distribute the material or use it for any profit-making activity or commercial gain
- You may freely distribute the URL identifying the publication in the public portal

If you believe that this document breaches copyright please contact us providing details, and we will remove access to the work immediately and investigate your claim.

REDUCTION OF DISPERSIVE GROUND-ROLL USING TIME DELAY SPECTROMETRY

Peter K. Møller¹ and Henrik C. Larsen²

¹Technical University of Denmark, Electronics Institute, Building 349, DK-2800 Lyngby, Denmark
²Ødegaard & Danneskiold-Samsøe ApS, 1 Kroghsgade, DK-2100 Copenhagen Ø, Denmark

ABSTRACT

Velocity filtering of seismic traces requires fulfilment of the sampling theorem in the time domain and in the space domain. Since the latter condition is seldomly met in exploration seismics, a method based on τ - p transformation combined with time varying filtering is proposed for solving the problem of reducing dispersive Ground-Roll in a seismic trace. Although it is possible to mask out Ground-Roll in the τ - p domain, mapping of the τ - p domain back into the original x - t domain involves numerical difficulties because the used inverse discrete Radon transform is ill-posed. To circumvent this problem the seismic trace is applied to a time varying filter with a stop-band which at any instant corresponds to the instantaneous frequency of the Ground-Roll, thus reducing the Ground-Roll with minimum distortion of the wanted seismic trace.

1. INTRODUCTION

Ground-Roll is a well-known major problem in land seismic exploration. Ground-Roll is due to the fact that a generated seismic signal may travel along the ground surface as well as through the geological layers of the underground. Since the velocity of the surface waves is low compared to the velocities of the signals that have been reflected at the boundaries of the geological layers these reflected signals may be corrupted by the Ground-Roll. Thus, Ground-Roll very often constitutes a serious problem for the interpretation of land seismic data. This is illustrated in figs. 1 and 3. Fig. 1 shows a synthetic seismogram with reflections from 5 boundaries in the underground and fig. 3 shows a seismogram contaminated with severe Ground-Roll. The illustrated problem has lead to the suggestion of numerous methods for reduction of Ground-Roll in the literature, see e.g. [1,2,3]. Many of the suggested methods are based on

velocity filtering which suffers from the seldomly fulfilled requirement that the sampling theorem must be

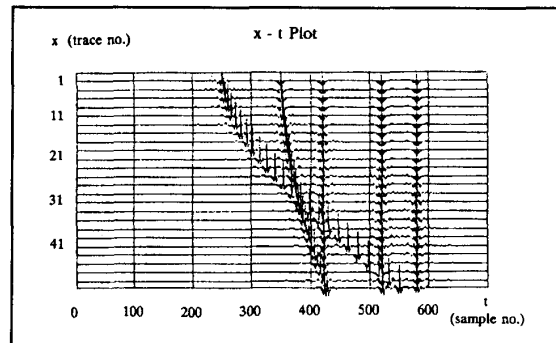

Figure 1. Seismogram with Reflection Hyperbolas from 5 Boundaries

met not only in the time domain but also in the space domain due to the implied 2-dimensional f - k transformation. This obstacle may be overcome using Radon or τ - p transformation, see e.g. [4]:

$$R(\tau, p) = \int_{-\infty}^{\infty} \int_{-\infty}^{\infty} u(x, t) \delta(t - \tau - px) dx dt \quad (1)$$

where x is the offset, t is the time, τ is the vertical travel time (interception), p is the ray parameter or the reciprocal of the horizontal phase velocity (slowness), u is the seismic trace.

This transformation maps the usual x - t domain into the τ - p domain. As one of the dimensions is the ray parameter it is possible in the τ - p domain to identify and distinguish waves with different ray parameters and thereby separate Ground-Roll and reflected signals. The Radon transform allows for the use of methods for discrimination of Ground-Roll based on masking in the τ - p domain and this is not fatally dependent on the space domain sampling interval. It thus seems to be an obvious alternative to the traditional velocity filtering if

it was not for one problem: These methods imply the use of the inverse Radon transform:

$$u(x,t) = \int_{-\infty}^{\infty} \frac{\partial}{\partial t} H[R(\tau,p)] dp \quad (2)$$

where H denotes Hilbert transform. However, unfortunately it turns out that the inverse discrete Radon transform is ill-posed [5]. Consequently there are severe problems with numerical stability which may result in extremely "noisy" results. These problems are the reason for investigating a novel method solely based on the forward Radon transform combined with suitable time varying narrow band filtering known also from time delay spectrometry [6]. The use of this method is based on the fact that in most cases the Ground-Roll is dispersive and may be modelled as a linearly frequency modulated wave [7].

2. TIME DELAY SPECTROMETRY AND THE GROUND-ROLL PARAMETERS

In the present case the Ground-Roll may be reduced with minimum distortion of the remaining signal (i.e. the wanted seismic trace) using a band-stop filter with a center frequency which at any time corresponds to the instantaneous frequency of the Ground-Roll. This calls for a filter with a center frequency which is linearly varying as a function of time. As the seismic reflections normally have a reasonably large bandwidth they will only be influenced in a comparatively small part of their spectrum provided that a suitably narrow band-stop filter is used. Implementation of the method thus requires a trade off between the wish for a narrow band-stop filter in order to minimize the distortion of the spectra of the reflections and a wish for a wide band-stop filter in order to keep the instantaneous frequency of the Ground-Roll within the frequency range of the filter and in order to keep the impulse response of the filter short. Another requirement of the method is that the Ground-Roll parameters must be determined. These parameters are: The starting time, t_{st} , the starting frequency, f_{st} , the end frequency, f_e , and the duration, T , of the Ground-Roll. The seismic trace may be expressed as [8]:

$$u(x,t) = \int_{-\infty}^{\infty} \int_{-\infty}^{\infty} \frac{K(k,f)}{D(k,f)} \exp(j2\pi(ft - kx)) df dk \quad (3)$$

where $K(k,f)$ is a function describing the signal source and $D(k,f)$ describes the dispersion properties. The Radon transform of (3) yields:

$$R(\tau,p) = \int_{-\infty}^{\infty} \frac{K(fp,f)}{D(fp,f)} \exp(j2\pi f\tau) df \quad (4)$$

which in turn may be Fourier transformed:

$$B(p,f) = \frac{K(fp,f)}{D(fp,f)} \quad (5)$$

The ray parameter may now in the case of dispersive waves be found as the maximum values in the f - p domain cf. fig. 5. Since the phase velocity, v_p , of the Ground-Roll equals $1/p$ the phase velocity as a function of frequency may also be found directly from fig. 5 and using

$$v_f = v_g \left(1 - \frac{f}{v_g} \frac{dv_g}{df}\right) \quad (6)$$

the maximum and minimum group velocity, v_g , and f_{st} and f_e may be calculated. It is also possible to calculate T for each seismic trace on the basis of a rough estimate for a reference trace. The only remaining parameter, t_{st} , is found by calculating the time lag which optimizes the cross correlation between the reference trace and the actual trace considered.

3. TIME VARYING SPECTROMETRY FILTER

As the exact instantaneous frequency of the Ground-Roll is not known in practice the applied band-stop

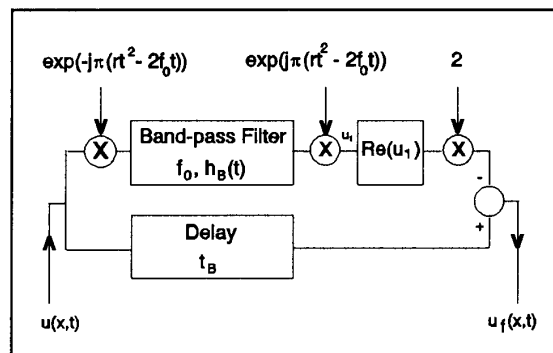

Figure 2. Spectrometry Filter Set-up

filter must have a suitable band-width, B , which in order to keep the instantaneous frequency of the Ground-Roll within the filter range must fulfil the requirement: $B \geq 2 |f_s(t) - f_c(t)|_{\max}$, where $f_s(t)$ is the instantaneous frequency of the Ground-Roll and $f_c(t)$ is the center frequency of the band-stop filter. As the amplitude of the linearly frequency modulated wave which models the Ground-Roll in practice varies as a function of frequency the Ground-Roll may be considered a constant amplitude frequency modulated signal which has been convolved with an impulse response, $h(t)$. This fact poses - due to the time variation of the band-stop filter - a further restriction on the band-stop filter. It can be shown [9] that in order to avoid sectioning of $h(t)$ the requirement $B > rd$, where d is the "duration" of $h(t)$, must be fulfilled. In the present case the band-stop filter is realized using a band-pass filter with fixed center frequency, f_0 , in a combination shown in fig. 2, where r is equal to $(f_c - f_{sl})/T$. The delay t_b compensates the delay in the band-pass filter. The set-up utilizes principles also known from quadrature modulation and reconstruction of band-pass signals, see e.g.[10].

4. EXPERIMENTS

In this section an example [11] of Ground-Roll reduction is described. First a seismogram con-

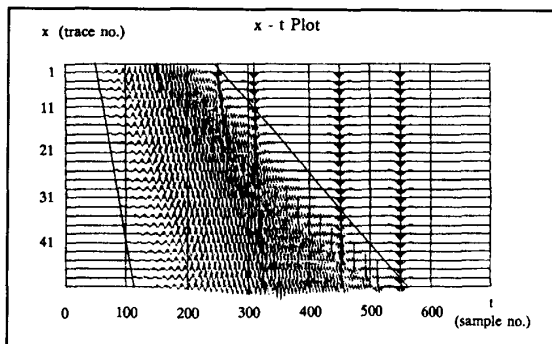

Figure 3. Ground-Roll Contaminated Seismogram

taminated with Ground-Roll is examined, cf. fig. 3, where the Ground-Roll is framed by two lines approximately corresponding to maximum v_g (left) and minimum v_g (right). Only minor parts of the reflection hyperbolas are visible. For reference the Radon transform of the seismogram in fig. 3 is shown in fig. 4. The Ground-Roll is seen as the elliptic area to the left. Taking the 1-dimensional Fourier transform for each discrete value of p with respect to τ yields the dispersion curve of fig. 5, from which it is clearly seen

that the center frequencies of the Ground-Roll are associated with the different values of p . As mentioned it is possible to estimate $v_{f,\max} = 1/p_{\min}$, $v_{f,\min} = 1/p_{\max}$

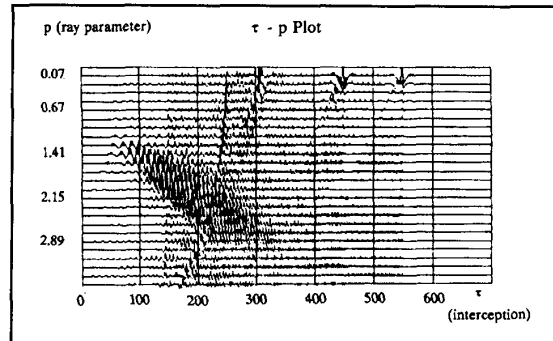

Figure 4. Radon Transform of Seismogram in Fig. 3

f_{\max} and f_{\min} . On the basis of the above mentioned cross-

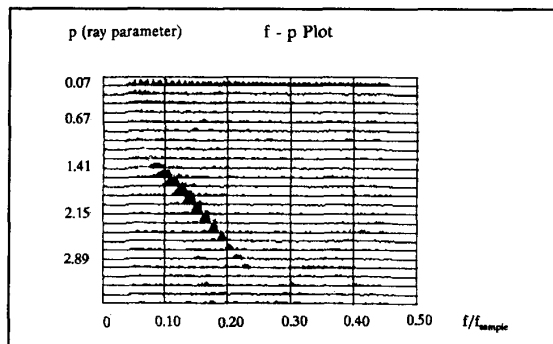

Figure 5. Dispersion Curve of Ground-Roll

correlation procedure performed on the last trace of the seismogram estimates for the starting time and the

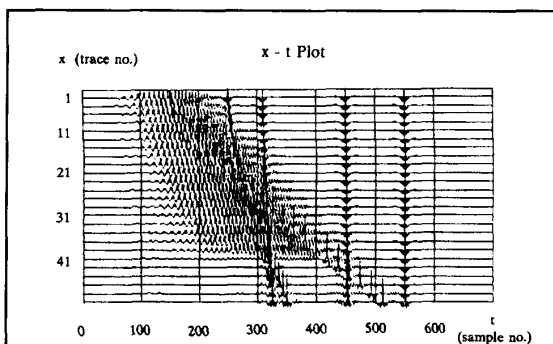

Figure 6. Filtered Seismogram. Initial Estimate

duration of the Ground-Roll for that trace are calculated. Since in practice there is a tendency to

underestimate the frequency range ($f_{\max} - f_{\min}$) this initial

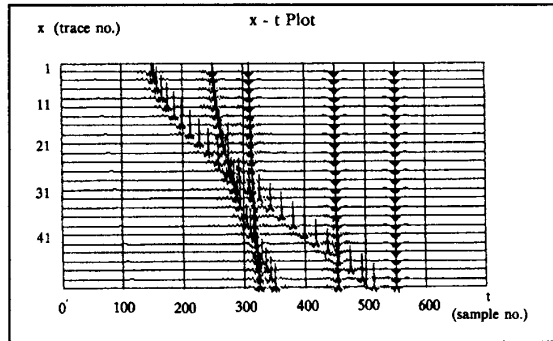

Figure 7. Filtered Seismogram. Final Estimate

estimate may turn out not to be sufficiently accurate for removal or reduction of the Ground-Roll on all traces. This is clearly seen on fig. 6, which shows the filtered output using the initial parameters. Further improvement is obtained using an iterative procedure, where the parameters are updated on the basis of visual inspection. After 4 iterations the result shown on fig. 7 is obtained. As can be seen the Ground-Roll has been reduced to an extent where all parts of the 5 reflection hyperbolas are revealed.

5. CONCLUSION

In this paper a method for reduction of dispersive Ground-Roll has been proposed. Unlike methods based on velocity filtering it does not depend on the sampling interval in the space domain, since it is based on repeated 1-dimensional time varying filtering in the time domain. The parameters for the filtering operation are derived from a forward Radon transform. The proposed method consequently does not suffer from the numerical problems known from methods based on the inverse Radon transform.

REFERENCES

- [1] Embree, P., Burg, J.P., and Backus, M.M., "Wide Band Velocity Filtering: The Pie-Slice Process", *Geophysics* 28, pp.948-974, 1963.
- [2] Fail, J.P., and Grau, G., "Les Filtres en Eventail", *Geophys. Prosp.*, 11, pp.131-163, 1963.
- [3] Hubral, P., "Stacking Filters and Their Characterization in the (f, k) Domain", *Geophys. Prosp.*, vol.22, pp.722-735, 1974.

[4] Helgason, S., "The Radon transform", Birkhauser, Boston 1980

[5] Tatham, R.H., "Multidimensional Filtering of Seismic Data", *Proc. IEEE*, vol.72, No.10, pp.1357-1369, 1984

[6] Heyser, R.C., "Acoustical Measurements by Time Delay Spectrometry", *JAES*, vol.15, No.4, 1967

[7] Saatcilar, R., and Canitez, N., "A Method of Ground-Roll Elimination", *Geophysics*, vol.53, No.7, pp.894-902, 1988

[8] Chapman, C.H., "A New Method for Computing Synthetic Seismograms", *Geophys. Journ. R. Astron. Soc.*, vol.54, pp.481-518, 1978.

[9] Pedersen, S.B., and Møller, P.K., "Time Delay Spectrometry: Possibilities and Limitations", *Proc. NAS-82*, Stockholm, 1982.

[10] Crochiere, R.E., and Rabiner, L.R., "Multirate Digital Signal Processing", Prentice-Hall, Englewood Cliffs, 1983.

[11] Larsen, H.C., "Methods for Elimination of Ground-Roll in Seismic Signals" (in Danish), Master Thesis, Electronics Institute, Technical University of Denmark, 1990.