

Technical University of Denmark



## The Danish C Band Sar. Calibration Accuracy And Stability

**Skou, Niels; Madsen, Søren Nørvang; Christensen, Erik Lintz; Netterstrom, A; Woolders, K.**

*Published in:*  
Geoscience and Remote Sensing Symposium

*Publication date:*  
1990

*Document Version*  
Publisher's PDF, also known as Version of record

[Link back to DTU Orbit](#)

*Citation (APA):*  
Skou, N., Madsen, S. N., Christensen, E. L., Netterstrom, A., & Woolders, K. (1990). The Danish C Band Sar. Calibration Accuracy And Stability. In Geoscience and Remote Sensing Symposium: Remote Sensing Science for the Nineties IEEE.

## DTU Library

Technical Information Center of Denmark

---

### General rights

Copyright and moral rights for the publications made accessible in the public portal are retained by the authors and/or other copyright owners and it is a condition of accessing publications that users recognise and abide by the legal requirements associated with these rights.

- Users may download and print one copy of any publication from the public portal for the purpose of private study or research.
- You may not further distribute the material or use it for any profit-making activity or commercial gain
- You may freely distribute the URL identifying the publication in the public portal

If you believe that this document breaches copyright please contact us providing details, and we will remove access to the work immediately and investigate your claim.

## THE DANISH C-BAND SAR. CALIBRATION ACCURACY AND STABILITY

N. Skou, S. N. Madsen, E. Lintz Christensen,  
A. Netterstrøm, and K. Woelders

Technical University of Denmark  
B 348, DK 2800, Lyngby, Denmark

### ABSTRACT

At the Electromagnetics Institute, Technical University of Denmark, an airborne C-band SAR has been designed and constructed. The first test flights has been carried out, and imagery with a verified resolution of 2.0 by 2.1 m have been acquired from a flight altitude of 41,000 ft. and a slant range of 25 km. The calibration and the stability of the radar have been of great concern during the design and development phase, and the present paper will highlight these aspects through a discussion of design considerations and stability measurements. Other aspects are covered in [1], [2], [3], and [4].

Keywords: SAR, C-band, calibration, stability.

### INTRODUCTION

In 1986 the design of the C-band SAR started, and following a busy development and construction phase, the first test flights were carried out ultimo 1989. The purpose of the endeavour is twofold: to acquire the expertise needed to deal with advanced, coherent radar systems, and to develop an instrument well suited for evaluation underflights in connection with the European remote sensing satellite ERS-1 (which includes a C-band SAR). This means that flexibility and calibration accuracy have been key factors in the design. Flexibility is ensured by using digital technology to the widest possible degree: the pulse generation and compression is done digitally, and the analog parts of the radar is computer controlled. Thus the bandwidth and coding of the transmitted pulses, the swathwidth, and the imaging geometry can be modified easily. Calibration accuracy is ensured by careful design including temperature stabilization of the analog circuitry, and several built-in calibration loops.

It is well recognized, that overall system calibration is not ensured by stable electronic circuitry and calibration loops, since the antenna is outside the loops. However, the design philosophy has been to eliminate so many uncertainties as possible so that future calibration work can concentrate on the important antenna aspects.

### THE C-BAND SAR

The Danish SAR operates at 5.3 GHz, it has a resolution down to 2 m by 2 m, a maximum range of 80 km and a swathwidth of 9 km using 2 m resolution. The swathwidth can be enlarged using degraded resolution.

The system block diagram is shown in **Figure 1**.

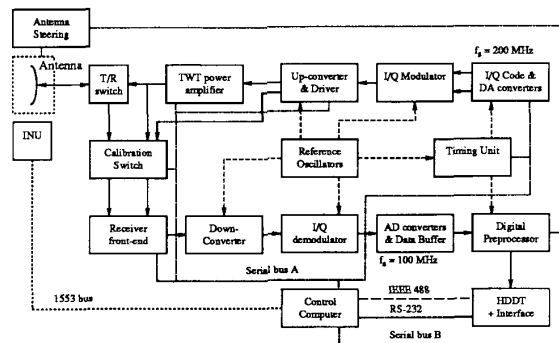

Figure 1: Block diagram

Great flexibility is ensured by using digital signal generation: the contents of two 4 kbytes memories are dumped to D/A converters at a 200 MHz rate thus generating the I and Q analog signals for the upconverter. Besides flexibility in code generation this also enables pre-distortion: known (measured) deficiencies in the transfer function of the analog part of the radar can be compensated by pre-distorting the digital code, and improved range sidelobe performance is achieved.

The upconverter transforms the baseband I & Q signals into a 5.3 GHz RF signal, suitable for driving the 2 kW Traveling Wave Tube (TWT) of the transmitter.

The antenna is a 1.2 m long slotted waveguide antenna with a modified cosecant squared elevation pattern. The polarization is vertical. The antenna is gimbal mounted with 3 degrees of freedom in a pod under a Gulfstream G-3 twin engine jet aircraft. In the pod an Inertial Navigation Unit (INU) is mounted thus sensing undesirable aircraft movements as close to the antenna as possible. Via the control

computer of the radar system, and an antenna control unit, the INU operates 3 electrical actuators moving the antenna properly in order to compensate the movements.

The received echoes are via the transmit/receive switch routed to the receiver, where amplification and downconversion to I and Q baseband signals are carried out. These signals are digitized to 8 bits per channel in two A/D converters running at a sampling rate of 100 MHz. The data buffers each hold 8 ksamples, corresponding to an 80  $\mu$ sec time window.

In order to obtain good radiometric fidelity for the measured radar data, the design must consider stability of the analog part of the radar and internal calibration possibilities in the radar system. Stability is ensured by careful design and by temperature regulation of all analog circuitry to  $40^{\circ}\text{C} \pm 1^{\circ}\text{C}$ . Several calibration loops are included in the radar. In Figure 1 it is shown how a sample of either the drive signal to the TWT or of the output signal from the TWT can be routed by the calibration switch to the receiver and injected either before or after the RF preamplifier. During the design phase it was not certain whether sufficient isolation could be obtained between transmitter and receiver to allow proper "reception" of the simultaneously operating transmitter: the stray and leak signals from the transmitter into the receiver have to be much smaller than the calibration signal to enable a proper calibration. Hardware tests have shown that this condition is fulfilled and thus confirmed the validity of the calibration concept.

The most satisfactory calibration is obtained by routing a sample of each transmitted pulse through the complete receiver and recording it on the digital tape recorder together with the received echo signals for later pulse-to-pulse comparison. This scheme does, however, consume a significant portion of the 80  $\mu$ sec data window due to the 20  $\mu$ sec long transmitted pulses. The practical solution is thus to record transmitted pulses for a short period before and after each ground scene to be sensed, and rely on instrument stability. Transmitted energy and peak power can be recorded pulse for pulse, thus enabling stability checks.

### STABILITY MEASUREMENTS

As an example of the stability measurements carried out on the radar system, **Figure 2** shows how the digital parts of the radar are used to evaluate the merits of the (analog) upconverter & receiver unit. The digital code generator feeds the upconverter with two constant amplitude tones at +12.5 MHz and -12.5 MHz. The C-band output signal from the upconverter is attenuated and detected, resulting in a 25 MHz signal that is feed to the Q channel input of the digital processor. A sample of the upconverter output signal is also feed into the receiver, whose I channel output is connected to the I channel input of the digital processor. With the described setup we are able to measure gain properties of the upconverter unit

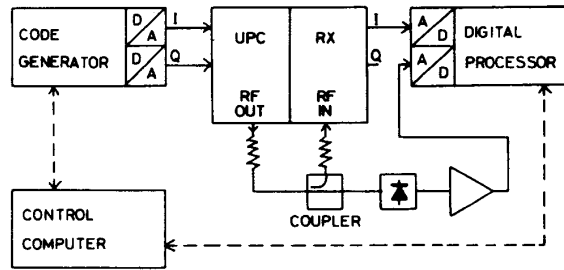

Figure 2: Upconverter and receiver being measured by digital parts of the radar

alone, and of the upconverter + receiver together. The receiver properties are found by subtracting the two sets of measurement data.

The result of one experiment is shown in **Figures 3-7**. The experiment begins shortly after the upconverter & receiver unit is switched on, but with the temperature regulation off. The temperature starts rising slowly, see Figure 3. Around  $t = 800$  sec the temperature control is switched on, and the temperature rises quickly and stabilizes around 40 centigrades.

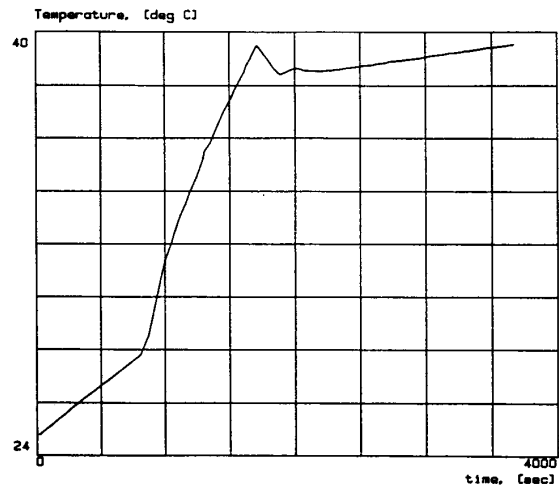

Figure 3: Temperature versus time

Figures 4 and 5 shows how the amplitude and phase of the RF output signal from the upconverter change with time as a result of the thermal exercise shown in Figure 3. The measurement values are shown relative to the first value i. e. the value at  $t = 0$  sec. Clearly, transient problems are present in the amplitude curve during the warm-up phase (where there is no thermal equilibrium in the unit), but apart from that, the final value is reached quite rapidly and it is not very dependent on the temperature. The phase is a smooth curve showing good correlation with the temperature. Thermal control of the upconverter to a nominal value  $\pm 1^{\circ}\text{C}$

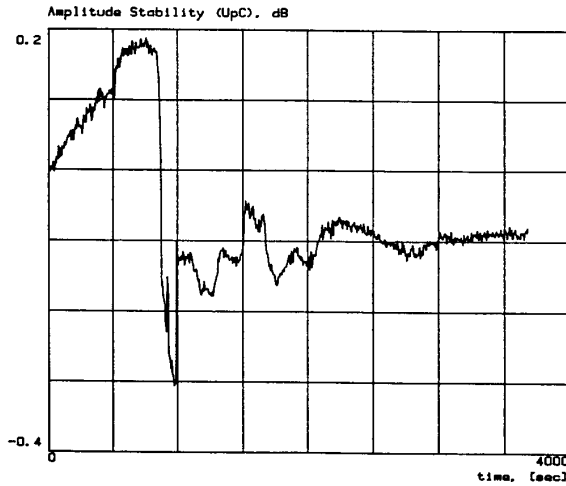

Figure 4: Amplitude stability of the upconverter

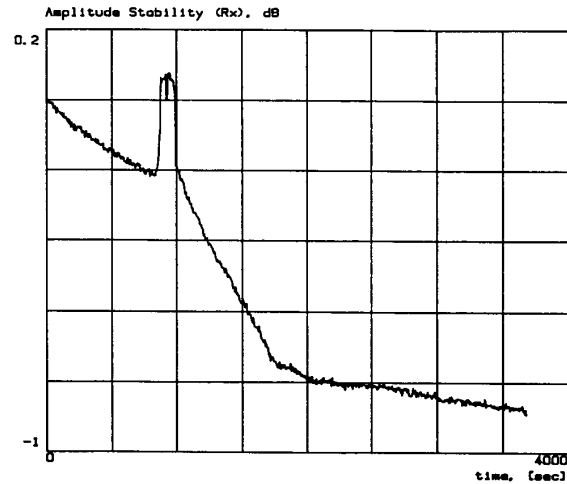

Figure 6: Amplitude stability of the receiver

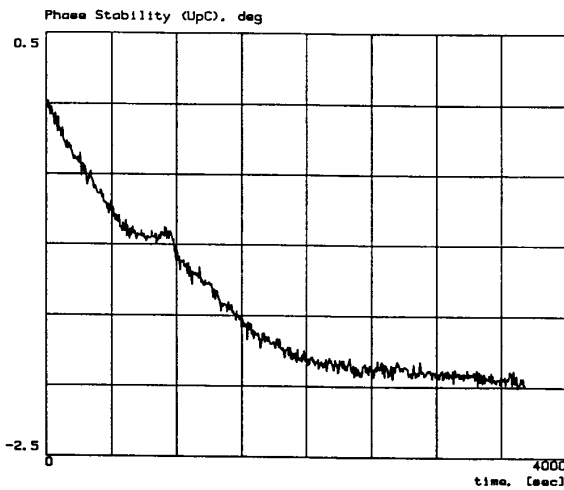

Figure 5: Phase stability of the upconverter

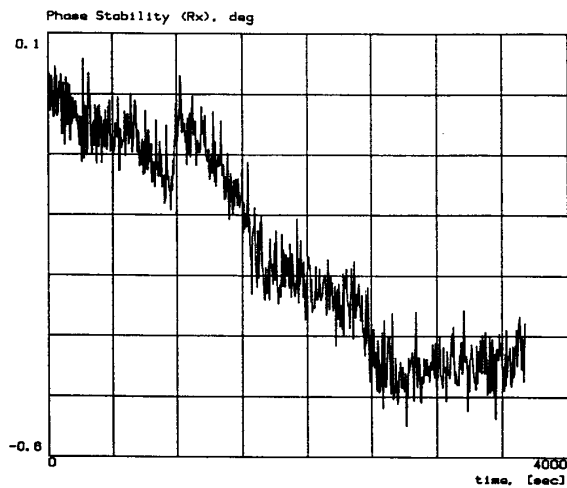

Figure 7: Phase stability of the receiver

is seen to ensure an amplitude stability of better than 0.1 dB and a phase stability of better than 0.5 deg. Figures 6 and 7 shows the gain and phase stabilities for the receiver. The peak in the amplitude response around  $t = 800\text{-}1000$  sec is probably an artifact stemming from the indirect determination of the receiver properties. It coincides perfectly well with the large jump in Figure 4. Both amplitude and phase show good correlation with temperature, and a thermal control of the receiver to better than  $\pm 1^\circ\text{C}$  will ensure an amplitude stability of better than 0.3 dB and a phase stability of better than 0.3 deg. It is important to recognize that the phase curves in Figures 5 and 7 represent the relative phase between the signals at  $5.3\text{ GHz} \pm 12.5\text{ MHz}$ . The stability of the absolute phase can be measured using a setup

similar to that of Figure 2. The detector circuit is omitted and the Q output from the receiver is connected to the Q input of the digital processor. It is now possible to measure the absolute phase stability, but it is no longer possible to separate variations caused by the upconverter from those caused by the receiver. **Figure 8** gives the result of one measurement.

The temperature variation observed during this measurement show the same course as that of Figure 3. The experiment begins at  $t = 0$  sec, and at  $t = 300$  sec the temperature regulation is switched on. The temperature begins stabilizing at  $t = 1500$  sec. The temperature variation is approximately  $1^\circ\text{C}$  from  $t = 1500$  sec to the end of the experiment. Figure 8 shows the variation of the absolute phase. The

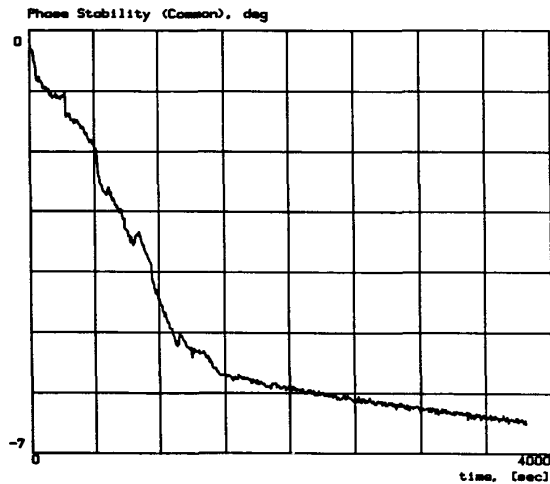

Figure 8: Absolute phase stability

behaviour is analogous to that of the previous experiment, but the absolute phase is more sensitive to temperature variations than the relative phase. A thermal control better than  $\pm 0.5$  °C will ensure an absolute phase stability of better than 1 deg. ( Note, however, that slow variations in the absolute phase is not a problem, as the important thing is changes within the aperture time, which is only a few seconds ).  
The thermal control circuitry is presently being

evaluated/modified to guarantee a tighter control, thus improving especially on the receiver amplitude stability. However, already with the existing control the performance is certainly adequate taking the calibration procedures into account. But it is always better if calibration can be regarded as calibration checks of something quite accurate, than if calibration is the primary way of getting accuracy out of something unstable.

#### ACKNOWLEDGEMENT

This work was carried out with support from the Thomas B. Thrige Foundation.

#### REFERENCES

- [1] Madsen, S. N., Christensen, E. L., and Skou, N., "KRAS - A Danish High Resolution Airborne SAR", 16<sup>th</sup> ISPRS Congress, Kyoto, 1988 Vol. 27, Part B1, Comm. I, pp. 90-97.
- [2] Skou, N., Madsen, S. N., Christensen, E. L., "The TUD C-band SAR", IGARSS '88, Edinburgh, Sept. 1988, pp. 1039-1040.
- [3] Netterstrøm, A., "Digital Correction of Analog Processing Errors", Int. Conf. on Radar 89, Paris, April 1989, Vol. 1, pp. 313-318.
- [4] Madsen, S. N., Skou, N., and Christensen, E. L., "A New C-band SAR for ERS-1 Underflights", Radar - 90, Arlington, May 1990.