

Technical University of Denmark



## Polarimetric Radiometer Configurations

**Skou, Niels; Laursen, Brian; Søbjerg, Sten Schmidl**

*Published in:*

Geoscience and Remote Sensing Symposium Proceedings, 1998. IGARSS '98. 1998 IEEE International

*Link to article, DOI:*

[10.1109/IGARSS.1998.702202](https://doi.org/10.1109/IGARSS.1998.702202)

*Publication date:*

1998

*Document Version*

Publisher's PDF, also known as Version of record

[Link back to DTU Orbit](#)

*Citation (APA):*

Skou, N., Laursen, B., & Søbjerg, S. S. (1998). Polarimetric Radiometer Configurations. In Geoscience and Remote Sensing Symposium Proceedings, 1998. IGARSS '98. 1998 IEEE International (Vol. 5, pp. 2324-2328). IEEE. DOI: 10.1109/IGARSS.1998.702202

## DTU Library

Technical Information Center of Denmark

---

### General rights

Copyright and moral rights for the publications made accessible in the public portal are retained by the authors and/or other copyright owners and it is a condition of accessing publications that users recognise and abide by the legal requirements associated with these rights.

- Users may download and print one copy of any publication from the public portal for the purpose of private study or research.
- You may not further distribute the material or use it for any profit-making activity or commercial gain
- You may freely distribute the URL identifying the publication in the public portal

If you believe that this document breaches copyright please contact us providing details, and we will remove access to the work immediately and investigate your claim.

## Polarimetric Radiometer Configurations

Niels Skou, Brian Lauersen, and Sten Søjberg  
 Danish Center for Remote Sensing, Dept. of Electromagnetic Systems  
 Technical University of Denmark (TUD), B-348, DK-2800 Lyngby, Denmark.  
 Phone: (45) 45 88 14 44, Fax: (45) 45 93 16 34, E-mail: ns@emi.dtu.dk

### ABSTRACT

Ocean wind speed and direction can be assessed with a polarimetric radiometer system measuring the full set of Stokes parameters. The first and second Stokes parameters are the sum and difference of the usual vertical and horizontal brightness temperatures. The third and fourth Stokes parameters can be found either by cross correlating the received vertical and horizontal electrical fields, or they can be found by a combination of properly polarized brightness temperature measurements.

These considerations directly point at two fundamentally different ways of implementing the polarimetric radiometer system. Paramount issues are instrument stability and sensitivity as well as the trade-off between increased microwave hardware complexity and fast digital correlator circuitry. Also, within each fundamental category there are significant trade-offs.

Based on such considerations a second generation airborne, imaging, polarimetric radiometer system is presently in its development phase. The design of the system is discussed.

### POLARIMETRY AND STOKES PARAMETERS

Generally, the radiation from an object is partly polarized meaning that the vertical brightness temperature  $T_V$  is different from the horizontal  $T_H$ . A well known example is the sea surface. To deal with partial polarization it is convenient to use the Stokes parameters. The Stokes vector is:

$$\vec{I} = \begin{pmatrix} I \\ Q \\ U \\ V \end{pmatrix} = \frac{1}{z} \begin{pmatrix} \langle E_V^2 \rangle + \langle E_H^2 \rangle \\ \langle E_V^2 \rangle - \langle E_H^2 \rangle \\ 2 \operatorname{Re} \langle E_V E_H^* \rangle \\ 2 \operatorname{Im} \langle E_V E_H^* \rangle \end{pmatrix}$$

where  $z$  is the impedance of the medium in which the wave propagates. It is seen that  $I$  represents the total power,  $Q$  represents the difference of the vertical and horizontal power components, while  $U$  and  $V$  represent the real and imaginary parts of the cross correlation of the electrical fields.

The brightness temperature Stokes vector is defined as:

$$\vec{T}_B = \lambda^2 / k \cdot \vec{I}$$

where  $\lambda$  is the wavelength and  $k$  Boltzmanns constant. The parameters of  $\vec{T}_B$  are termed  $I_B$ ,  $Q_B$ ,  $U_B$  and  $V_B$  where  $I_B = \lambda^2 / k \cdot I$  and so on. It can be shown that:

$$\begin{aligned} U_B &= T_{45^\circ} - T_{-45^\circ} \\ V_B &= T_l - T_r \end{aligned}$$

where  $T_{45^\circ}$  and  $T_{-45^\circ}$  represent orthogonal measurements skewed  $45^\circ$  with respect to normal and  $T_l$  and  $T_r$  refer to left-hand and right-hand circular polarized quantities.

Normally, in the radiometer literature the Stokes parameters  $I$ ,  $Q$ ,  $U$ ,  $V$  directly means the **brightness** Stokes parameters (rightfully termed  $I_B$  etc.) so we can write:

$$\vec{T}_B = \begin{pmatrix} I \\ Q \\ U \\ V \end{pmatrix} = \begin{pmatrix} T_V + T_H \\ T_V - T_H \\ T_{45^\circ} - T_{-45^\circ} \\ T_l - T_r \end{pmatrix} = \frac{\lambda^2}{k \cdot z} \begin{pmatrix} \langle E_V^2 \rangle + \langle E_H^2 \rangle \\ \langle E_V^2 \rangle - \langle E_H^2 \rangle \\ 2 \operatorname{Re} \langle E_V E_H^* \rangle \\ 2 \operatorname{Im} \langle E_V E_H^* \rangle \end{pmatrix}$$

and we shall adopt this notation here.

This definition expression directly points at two fundamentally different ways of implementing the polarimetric radiometer system. The first and second Stokes parameters are of course measured the conventional way using vertically and horizontally polarized radiometer channels. The third Stokes parameter can be measured with a normal 2-channel radiometer connected to a normal orthogonally polarized antenna skewed  $45^\circ$ . The fourth Stokes parameter can be measured with the 2-channel radiometer connected to a left-hand / right-hand polarized antenna system. We shall use the term "polarization combining radiometer" in the following. However, all Stokes parameters are immediately measured by a 2-channel correlation radiometer connected to a normal horizontally & vertically polarized antenna system. We shall of course use the term "correlation radiometer" in the following.

### RADIOMETRIC SIGNATURES OF THE OCEAN

The brightness temperature of the ocean depends on the wind speed. At incidence angles around  $50^\circ$ , and in the frequency range of interest here, the  $K_u$  and  $K_a$  bands, the dependence is small at vertical polarization: some 0.5 K per m/sec wind, and somewhat larger at horizontal polarization: 1 - 1.5 K per m/sec wind, see f. ex. [1]. This means that a traditional radiometer measurement with an accuracy of 1 K

enables determination of the wind speed to better than 1 m/sec (excluding other error sources), which can be regarded as quite satisfactory. But the measurement of the Stokes parameters may place more stringent requirements to the accuracy of the radiometers. Typical variations in Q and U are 4 - 6 K peak to peak and less regarding V, see [2], [3], [4]. This means that measurement accuracies must be a fraction of a Kelvin, which is not easy for traditional radiometers.

#### FOUR CONFIGURATIONS

##### Polarization Combining Radiometers

The first configuration to be discussed is the *full multiplex polarization combining radiometer* as outlined in Figure 1.

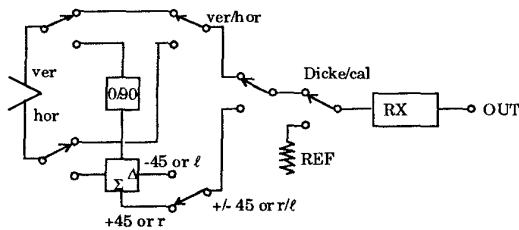

Figure 1: Full multiplex polarization combining radiometer

The outputs from a normal horizontally & vertically polarized antenna are via a switchable microwave combination network connected to a single radiometer carrying out all necessary measurements in sequence. The switches can be PIN diode switches or latching circulators. By combining the horizontal and vertical signals in a magic tee, providing the sum and difference signals, we obtain +45 and -45 degree linear polarizations (phase shifter set to 0°). With the phase shifter set to 90°, the combined signals from the magic tee become right- and left-hand circular polarizations. A switch and reference load for Dicke operation or frequent calibration is also shown in front of the receiver.

The pros (+) and cons (-) (• is a neutral comment) of this radiometer system are:

- + With a suitable switching sequence we obtain a very satisfactory determination of the important second and third Stokes parameters even without Dicke switching: they are found by subtracting the output values from one single receiver where the input is switched rapidly between two signals - quite analog to the situation in a traditional Dicke radiometer, and gain and noise drifts / fluctuations are largely cancelled.
- + Only one radiometer receiver is required.
- With Dicke switching or frequent calibration we also get a good determination of the normal  $T_H$  and  $T_V$  signals.

- The system sensitivity is hampered by substantial loss in the polarization combining network (may be alleviated by pre-amplifiers up front).
- Very poor potential sensitivity due to low duty cycle: all measurements have to be multiplexed through a single receiver. Sensitivity may be regained with long integration time, precluding the use of this configuration in imaging systems where short integration time normally prevails.
- Complicated microwave combining and switching hardware.

A system of this type has been used with great success by JPL for their airborne, profiling (non imaging) measurements of ocean waves [2], [3].

The second configuration to be discussed is the *parallel receiver polarization combining radiometer* as shown in Figure 2.

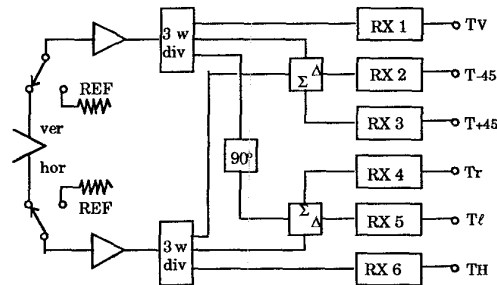

Figure 2: Parallel receiver polarization combining radiometer

In fact it is an alternative version of the system described above, where the same polarization combinations are produced, not sequentially by switching, but simultaneously using power dividers (and again magic tees and a 90 degree phase shift). Pre-amplifiers (with substantial gain) up front is a necessity in this configuration or the power divider scheme would completely ruin sensitivity. 6 identical radiometers are required to measure the different polarization combinations.

The pros and cons of this system are:

- + Parallel channels ensure optimum sensitivity (no duty cycle problems) directly pointing towards applications in imaging systems be it airborne or spaceborne.
- Q, U, and V are found by subtraction of individual receiver's outputs, leading to potential stability problems. The problem is partly alleviated by proper design where identical receivers track in temperature and supply voltages, and by Dicke switching or frequent calibration. In the present case Dicke switching is not attractive due to the sensitivity penalty, whereas frequent calibration is readily possible while the scanning antenna looks away from the useful swath anyway (ref. SSM/I and MIMR).
- With frequent calibration also good determination of  $T_V$  and  $T_H$ .
- 6 receivers and complex microwave hardware.

### Correlation Radiometers

The first system to be described under this headline is the *basic correlation radiometer* shown in Figure 3. Two identical receivers are connected to the horizontal and vertical outputs of the antenna system. The outputs of the receivers are detected the usual way to yield the normal horizontally and vertically polarized brightness temperatures. The outputs of the receivers are also (at IF level) fed into the complex correlator providing the U and V Stokes parameters (the real and the imaginary outputs). The complex correlator consists of two sections each having a multiplier and an integrator. The real section operates directly on the outputs from the receivers, while the imaginary section multiplies the output from one receiver with the output from the other, phase shifted 90°. The correlator can be implemented in analog or digital technology. In the following, digital implementation is assumed due to better stability, and technology is no longer a problem for typical radiometer bandwidths around 500 MHz or less. See for example [5] for a brief description of such circuitry. The radiometers are generally implemented as super heterodyne receivers to enable the correlator to work at a suitable IF frequency. The correlation technique requires phase coherence between the two receivers. This is achieved by using one common local oscillator.

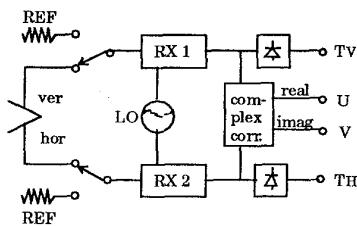

Figure 3: Basic correlation radiometer

Pros and cons are:

- + Parallel channels ensure optimum sensitivity.
- + U and V are very well determined. This is associated with the way in which the correlation radiometer works. The output of the digital correlator is the correlation coefficient  $\rho$  (typically around 0.01) which must be multiplied with the total system temperature  $T_S$  (typically around 500 K) to yield the true cross correlation between the two channels. The error in U can be expressed as  $\Delta U = \Delta \rho \times T_S + \rho \times \Delta T_S$ . Due to the small value of  $\rho$ , the second term vanishes with any reasonable radiometric error, and the first term is very small as a digital correlator can be made almost perfect.
- + Simple microwave circuitry
- Q found by subtraction of individual receiver's outputs - see discussion above concerning the parallel receiver polarization combining system.
- With frequent calibration also good determination of  $T_V$  and  $T_H$ .

- Fast digital correlator. In the past digital circuitry with clock frequencies around 1 GHz was bulky and power consuming. However, with present day technology a 3-level complex digital correlator can be implemented in a single chip consuming no more than 1 W of power.
- Local oscillators are generally serious power consumers. However, for radiometers we need not the many mW units generally available on the market. Some special, but low risk, development is required to obtain power optimized oscillators delivering just the required microwave power for a low level mixer.

A system of this type has been used by the authors for their airborne measurements of ocean waves, see [4].

The final system considered in this text is the *switching correlation radiometer* outlined in Figure 4. It is just a small enhancement of the basic correlation radiometer where a cross-over switching arrangement is added between the antenna and the receivers, and corresponding synchronous demodulators are added after the detectors. All switches and synchronous demodulators operate simultaneously. A fast switching sequence like in a Dicke radiometer is assumed. Each of the two radiometers will now act as a Dicke type switching radiometer on the difference between vertical and horizontal polarization with the associated, well known stability. The correlation processes are not influenced by the switching (the imaginary signal must be demodulated like the Q signals, which is easy in the digital circuitry, and not shown in the figure).

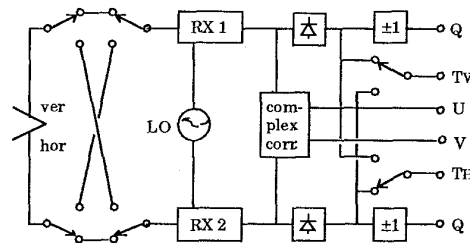

Figure 4: Switching correlation radiometer

Pros and cons are:

- + Parallel channels ensure optimum sensitivity
- + The important Stokes parameters Q, U, and V are all very well determined.
- With frequent calibration also good determination of  $T_V$  and  $T_H$ . Note that calibration switches and loads are not shown in Figure 4.
- Slightly more complicated microwave circuitry.

### Discussions of Configurations

For basic airborne measurements of polarimetric signatures using circle flights with a staring (non imaging) radiometer, the first configuration, the full multiplex polarization combining radiometer, is a strong candidate due

to its relative simplicity and its very good determination of the important 3 Stokes parameters Q, U, and V.

For any imaging applications, as for example a future spaceborne wind-over-the-ocean mission, only the 3 other configurations are candidates due to severe requirements to sensitivity. The correlation technique seems to be a strong candidate, trading substantial microwave hardware for fast digital circuitry. With present technology, the required digital correlator is not a great challenge, and time works for us in all cases regarding space technology but especially within the digital regime.

The choice between the basic correlation radiometer and the enhanced switching version is not straight forward. No doubt, the switching system is superior in determining the Q parameter, but the question is, whether a modern, well designed, paired set of receivers cannot do an adequate job. This requires further investigations of real hardware.

### THE EMIRAD POLARIMETRIC SYSTEM

The airborne, imaging, polarimetric EMIRAD system employs  $K_u$  and  $K_a$  band polarimetric radiometers of the basic correlation type as described above. They are of identical design.

The correlation radiometer employs two single sideband super heterodyne receivers, see Figure 5. The local oscillator frequency is 16 (34) GHz and the IF band is 75 - 475 MHz. The two receivers are connected to the vertical and the horizontal outputs of a dual polarized feed horn. Fast switches (latching circulators) are included for frequent calibration or even Dicke type switching operation.

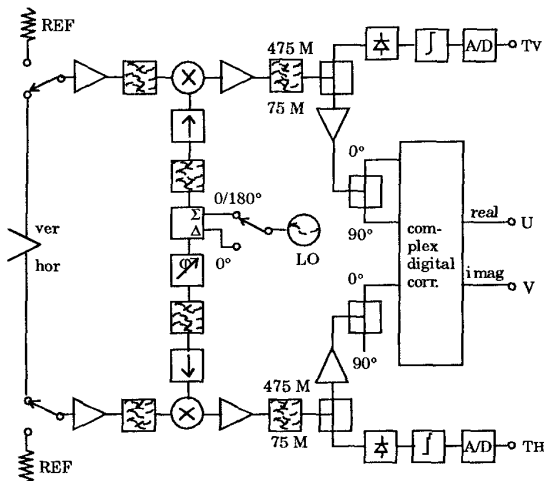

Figure 5: EMIRAD correlation radiometer

The correlation technique requires phase coherence between the two receivers in order to measure the complex correlation between input signals. This is achieved by using one common local oscillator. The phase shifter between the

local oscillator and the mixer in the horizontal channel is adjusted to maximize the real part of the output signal (minimize the imaginary output) for equal, correlated input signals. These signals are generated by an external calibration system. Experience has shown excellent phase stability and that the phase shifter only has to be checked and possibly adjusted when cables or components of the radiometer have been disconnected and reassembled.

High isolation between the two channels is required and the local oscillator distribution circuitry is especially critical. A minimum isolation of 70 dB at RF as well as IF frequencies is obtained by a combination of isolators and waveguide filters.

The network used to feed the analog detectors and the digital correlator consists first of an in-phase 2-way power divider used to divide the signal between the digital correlator and the analog detector circuit, and secondly a quadrature hybrid to make in-phase and 90° out-of-phase signals for the correlator. The analog detector is a tunnel diode detector followed by an integrator.

The digital correlator consists of a multilayer printed circuit board with a three level (2 bit) A to D conversion at the input and proper multipliers. The sampling rate is 1540 MHz and an 8 msec averaging is carried out on the correlator outputs. The circuit board also holds circuitry for monitoring the quantization levels. This information is used for normalization of the correlation values.

Offsets on the output of the correlator are reduced significantly by phase switching of the local oscillator signals and proper demodulation after the correlator. This is implemented by switching the local oscillator at a 1 kHz rate between the sum and difference ports of a magic tee. The demodulation is done inside the digital correlator. Injection of uncorrelated noise in the two receivers from two independent loads is used to calibrate for the remaining offsets. The loads may be the same as those used for frequent calibration checks as well.

The analog integration in the total power radiometers is 4 msec, and later a digital integration to 8 msec is carried out. The resulting radiometric sensitivity is 0.3 K. The sensitivity of the correlation measurement is degraded by a factor of 1.15 from 0.3K to 0.35 K for a three level digital correlator with a factor 1.6 oversampling rate as in the present case [5].

### FUTURE PLANS

The radiometer system just described will be combined with an existing 1m aperture scanning reflector antenna system, designed for operation from the open ramp of a C-130 Hercules transport aircraft. Several campaigns will be carried out over the ocean during 1998, to further confirm polarimetric signatures and to investigate imaging properties.

### ACKNOWLEDGMENTS

The work described in the present paper was funded by the Danish National Research Foundation.

## REFERENCES

- [1] Y. Sasaki, I. Asanuma, K. Muneyama, G. Naito, and T. Suzuki, "The Dependence of Sea-Surface Microwave Emission on Wind Speed, Frequency, Incidence Angle, and Polarization over the Frequency Range from 1 to 40 GHz", *IEEE Trans. on Geoscience and Remote Sensing*, Vol. GE-25, No. 2, March 1987.
- [2] S. H. Yueh, W.J. Wilson, S.V. Nghiem, F.K. Li and W.B. Ricketts, "Polarimetric Measurements of Sea Surface Brightness Temperatures using an Aircraft K-Band Radiometer", *IEEE Trans. Geosci. Remote Sensing*, Vol 33, No. 1, January 1995.
- [3] S. H. Yueh, W.J. Wilson, S.V. Nghiem, F.K. Li and W.B. Ricketts, "Polarimetric Brightness Temperatures of Sea Surfaces Measured with Aircraft K- and Ka-Band Radiometers", *IEEE Trans. Geosci. Remote Sensing*, Vol 33, No. 1, January 1995.
- [4] B. Laursen and N. Skou, "POLRAD-96: The TUD Polarimetric Radiometer Measurements", *Proceedings of the POLRAD-96 workshop, ESTEC WPP-135*, August 1997.
- [5] A. R. Thompson, J. M. Moran, and G. W. Swenson, "Interferometry and Synthesis in Radio Astronomy", Krieger Publishing Co., Florida, 1991.