

Technical University of Denmark



3 kW Stirling engine for power and heat production

Thorsen, Jan Eric; Bovin, Jonas Kabell; Carlsen, Henrik

Published in:

Energy Conversion Engineering Conference, 1996. IECEC 96. Proceedings of the 31st Intersociety

Link to article, DOI:

[10.1109/IECEC.1996.553902](https://doi.org/10.1109/IECEC.1996.553902)

Publication date:

1996

Document Version

Publisher's PDF, also known as Version of record

[Link back to DTU Orbit](#)

Citation (APA):

Thorsen, J. E., Bovin, J. K., & Carlsen, H. (1996). 3 kW Stirling engine for power and heat production. In Energy Conversion Engineering Conference, 1996. IECEC 96. Proceedings of the 31st Intersociety (Vol. 2, pp. 1289-1294). IEEE. DOI: 10.1109/IECEC.1996.553902

DTU Library

Technical Information Center of Denmark

General rights

Copyright and moral rights for the publications made accessible in the public portal are retained by the authors and/or other copyright owners and it is a condition of accessing publications that users recognise and abide by the legal requirements associated with these rights.

- Users may download and print one copy of any publication from the public portal for the purpose of private study or research.
- You may not further distribute the material or use it for any profit-making activity or commercial gain
- You may freely distribute the URL identifying the publication in the public portal

If you believe that this document breaches copyright please contact us providing details, and we will remove access to the work immediately and investigate your claim.

3 kW STIRLING ENGINE FOR POWER AND HEAT PRODUCTION

Jan Eric Thorsen, Jonas Bovin, Henrik Carlsen
Institute of Energy Engineering
The Technical University of Denmark
Building 403
DK-2800 Lyngby, Denmark
Phone +45 45 25 41 71
Fax +45 45 93 06 63

ABSTRACT

A new 3 kW Beta type Stirling engine has been developed. The engine uses Natural gas as fuel, and it is designed for use as a small combined heat and power plant for single family houses. The electrical power is supplied to the grid.

The engine is made as a hermetic device, where the crank mechanism and the alternator are build into a pressurized crank casing. The engine produce 3 kW of shaft power corresponding to 2,4 kW of electric power. The heat input is 10 kW corresponding to a shaft efficiency of 30 %, and an electric efficiency of 24 %. Helium at 8 MPa mean pressure is used as working gas.

The crank mechanism is a combination of an upper- and lower yoke, each forming the half of a Ross mechanism. The upper yoke is linked to the displacer piston and the lower yoke is linked to the working piston. The design gives an approximately linear couple point curve, which eliminates guiding forces on the pistons and the need for X-heads. Grease lubricated needle and ball bearings are used in the kinematic crank mechanism.

The burner includes an air preheater and a water jacket, which makes it possible to utilize nearly all of the heat from the combustion gasses.

The performance of the engine has been tested as a function of mean pressure and hot and cold temperature, and emissions and noise have been measured.

INTRODUCTION

In areas with single family houses where natural gas is

available, combined heat and power (CHP) can be established by installing small individual plants in the houses.

An analysis of the heat consumption of a typical Danish single family house showed, that the heat output of the engine should be around 6 kW. The engine would then run for around 5000 hours per year and nearly all of the heat for the house could be produced by the engine. In the spring and in the autumn, where the demand of heat is smaller, the engine should run in the daytime where the electric power is expensive, and the heat should be accumulated and used in the night.

The demands for such an engine are:

high efficiency
long lifetime
low emissions
low demands for maintenance
low noise and non-vibrating

An engine producing 6 kW of heat will produce approximately 2.5 kW of electricity resulting in a quite small engine compared to common internal combustion engines.

A Stirling engine has the potential to fulfill the requirements. Therefore an engine for this purpose was designed, built and tested during a master thesis at Technical University of Denmark. The heater head with regenerator and cooler came from a Vuilleumier heat pump, which has been tested a few years before. (Carlsen, 1989).

ENGINE LAYOUT

The engine is designed as a semi hermetic unit in the same

way as a semi hermetic refrigeration compressors. Crank mechanism and alternator are build into the crank casing, which is pressurized to engine mean pressure. The working gas is helium and the mean pressure is 8 MPa .

By using this design, leaks of helium to the atmosphere from dynamic seals are avoided. Static O-ring seals are used between the removable parts of the engine housing. This allows a simple piston rod sealing design. Furthermore a little symmetric leak is acceptable and necessary to keep to the mean pressure in the crank housing.

It is a single cylinder engine, where displacer and working piston is in the same cylinder (beta-type). An annular design is used for the heater, regenerator and cooler, see fig. 2. The heater tubes connect the expansion volume with the top of the regenerator. The outer tube row are mounted with fins, in order to increase heat transfer.

The cooler is a tube and shell type, where the working gas flows inside the thin tubes, while the cooling water flows outside the tubes in an annular chamber. The regenerator is made of stainless steel thread, which has treated in a special way and formed into the desired shape.

The crank casing is made from 160 mm sheet, which has been flame cut into the desired shape and welded together with a tube with cap for the containment of the alternator. The crank casing has then been machined into the final dimensions.

Oil in the crank casing has been avoided by using grease lubricated needle and ball bearings. The piston seals, the rod seals and the guiding rings on the pistons are made from Teflon type materials with o-ring backup.

The crank mechanism is a combination of an upper and a lower yoke. Each yoke can be regarded as a half Ross drive (Ross 1985), see fig.1. The couple point for the upper yoke is linked to the displacer piston and the couple point for the lower yoke is linked to the working piston.

The positions of the coupler point curve for the displacer- and working piston represents almost straight lines. A comparison between a straight line and the actual movement of the coupler point can be evaluated by making the best fit with a straight line and calculate the maximum distances between this straight line and the coupler point curve. The side movement of the coupler point is the sum of the maximum deviations.

The final dimensions of the mechanism parts area result of compromises between total crank housing size, stroke, linearity, piston phase angle and forces in the links and on the crank shaft. The nearly linear movements of the coupler points to the piston connecting rods eliminates the need for cross heads. That is important, as there is no oil in the crank casing for the lubrication of a cross head.

The geometry of the mechanism results in a phase angle of 87° , which differs somewhat from the optimum angle at approx. 70° . This is an disadvantage of the crank mechanism design, but in fact the thermodynamic consequences are acceptable. The consequence of a phase angle closer to the optimum will be a larger engine housing or a less linear coupler curve for the same size of engine house.

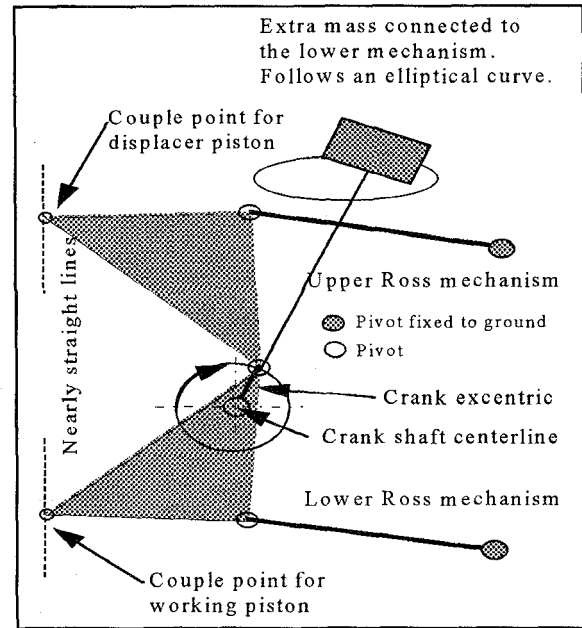

FIG. 1. Crank mechanism for 3 kW Stirling engine

The stroke of the displacer piston is 33,6 mm, which corresponds to a movement perpendicular to the cylinder axis of 0,094 mm. This movement can be tolerated by the displacer piston rod sealing, as the total bearing clearance of the crank mechanism is approximately the same size. The ratio between the stroke and the lateral movement is approximately 360.

A better linearity can be obtained by increasing the length of rocker arms and the size of the yokes, but for the same stroke the engine housing will be larger.

The stroke of the working piston is 36,5 mm, corresponding to a lateral movement of 0,185 mm. The ratio between the stroke and the lateral movement is approximately 200. The working piston has a larger lateral movement, which can be tolerated because of a longer piston rod and comparatively small dimension of the piston length.

On the lower yoke (see figure 1) there is mounted an extra mass above the triangle element. This extra mass is a part of the dynamic balancing system of the engine. The vertical component of the mass forces from the pistons and the crank mechanism can be eliminated by a counter balance on the flywheel. This generates a horizontally component, which almost can be eliminated by the extra mass on the yokes.

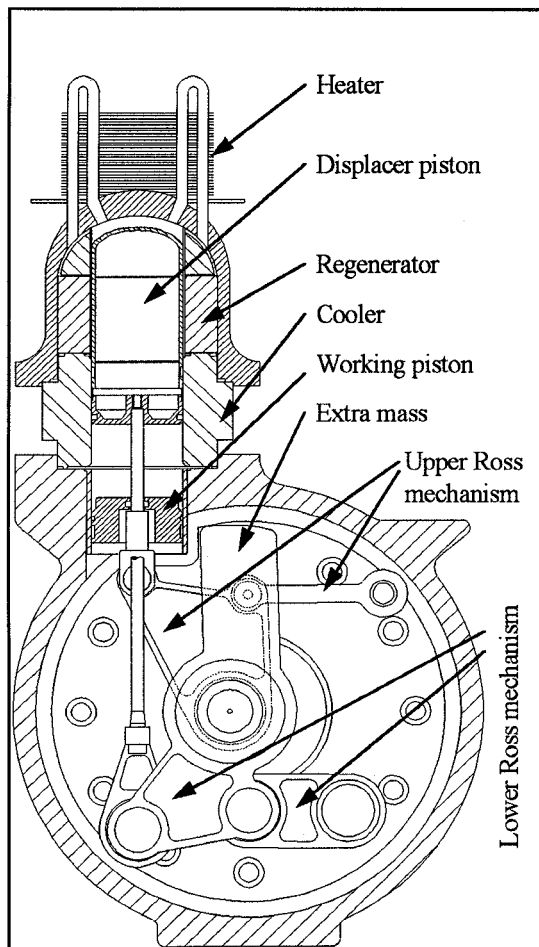

FIG. 2 Front view of 3 kW Stirling engine

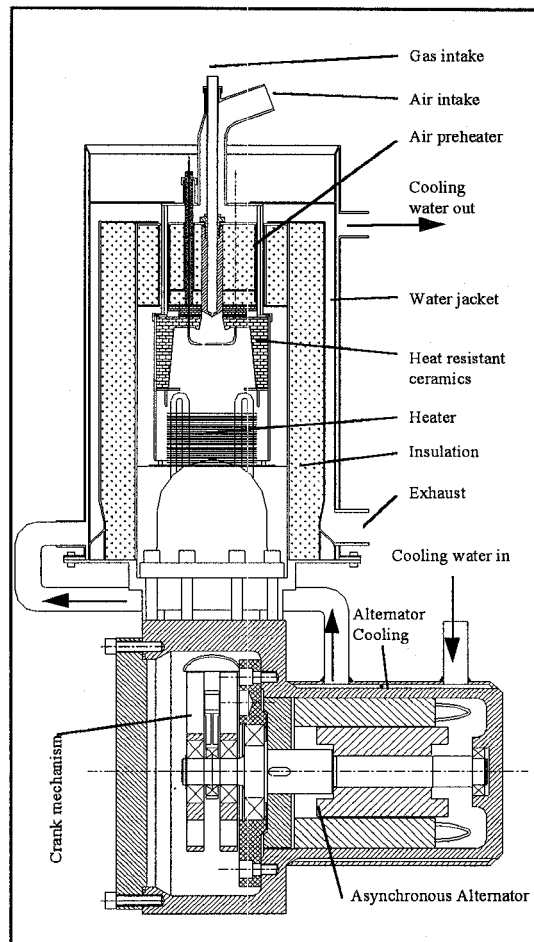

FIG. 3 3 kW Stirling engine with heater section

Fig. 3 shows the burner system for the engine. The design follows common practice for Stirling engine heating. The burner includes an air preheater and a water jacket, which makes it possible to utilize nearly all of the heat from the combustion gasses.

The engine is made for on-off control. A valve connects the working volumes with the crank housing, so that power is on when the valve is closed and off when the valve is open. When the engine is connected to the grid there is no need for a speed control system, as the speed is controlled by the frequency of the grid. The valve is also used for easy starting and for emergency shut down.

Fig. 4 is a photo of the engine on the test bed, without the burner.

FIG. 4. Photo of the engine.

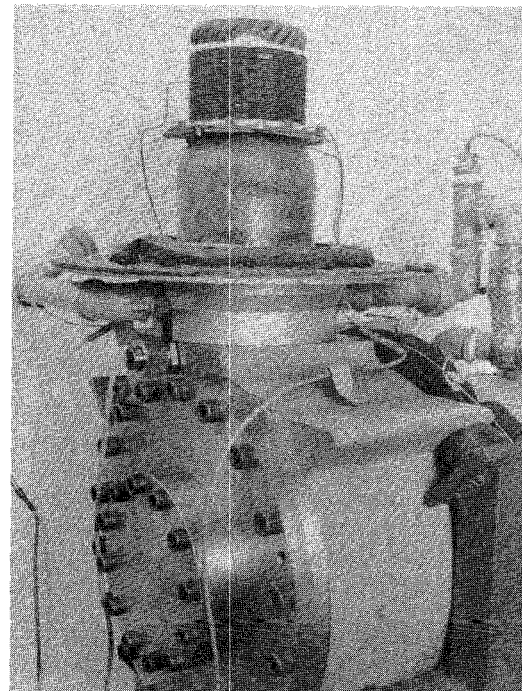

Table 1. Specifications for the 3 kW Stirling engine:

Cylinders	Displacer piston	Working piston
Bore, mm	60	60
Stroke, mm	33,6	36,5
Piston rod diam., mm	8	
Piston clearance, mm	1,5	1,5
Dead volume, cm ³	12	18
Heat exchangers (Cylindrical tubes)	Hot	Cold
Length, mm	140	78
Internal diam., mm	3	1,2
Number of tubes	24	360
Dead volume, cm ³	24	4

Regenerator

Length, mm	50
External diameter, mm	105
Internal diameter, mm	65
Filler factor	0,25

Other engine specifications

Working gas	Helium
Mean pressure, MPa	8
Phase angle	87 °
Max. heater temp, °C	725 °C
Engine speed, rpm	1535
Alternator eff. %	78
Fuel	Natural gas
Weight incl burner, kg	100

TEST RESULTS

The engine has been tested at different temperatures and mean pressures. After that a 300 hours duration test has been made. Totally the engine has been running for around 360 hours.

Figure 5, 6 and 7 shows the results from the tests with a temperature in the cooling water of 35°C. Figure 5 shows the shaft power as a function of heater temperature at 3 different mean pressures, and figure 6 shows the shaft and electric efficiency as a function of the heater temperature at maximum mean pressure, 8.5 MPa.

From figure 5 it can be seen, that the shaft power is nearly proportional to the heater temperature and helium pressure. It shows also that the design power of 3 kW has been obtained.

Figure 6 shows, that maximum shaft efficiency of 30% is obtained at maximum heater temperature as expected. Figure 6 also shows the difference between shaft, and electrical efficiency. Note that the alternator efficiency is poor, only 72% - 78%.

The shaft power has been calculated from the electric power and the efficiency of the alternator. The efficiency of the alternator was measured in a test rig, where the alternator was

connected to an electric motor controlled by a frequency converter.

The characteristics of the alternator, which is actually an ordinary asynchronous motor, was expected to be exactly the same, as if the characteristics of the same unit as a motor. However, the efficiency of the alternator was found to be smaller, as the efficiency as an alternator was 78% at full load while the efficiency as a motor is 81% .

The power factor $\cos\phi$ of the alternator was only 0.5, which is much lower than the corresponding value of 0.8 for the motor. With a custom designed alternator, an efficiency of 85 % or more can be achieved. The power factor can also be improved.

Figure 8 and 9 shows the results from the tests with a temperature in the cooling water of 65°C. Figure 8 shows the shaft and electric efficiency as a function of heater temperature, and figure 9 shows the power, both shaft and electric, as a function of the heater temperature.

A comparison of figure 5 to 9 shows, that the increased cooling water temperature results in a loss of power of 250 W and the efficiency is 1% lower.

The engine is mounted in a partly open box of concrete. Outside the box the noise of the engine has been measured to 60 dB(A).

After the above mentioned test program the engine has been run for about 300 hours without sign of wear or degradation of performance. The tests will be continued if possible.

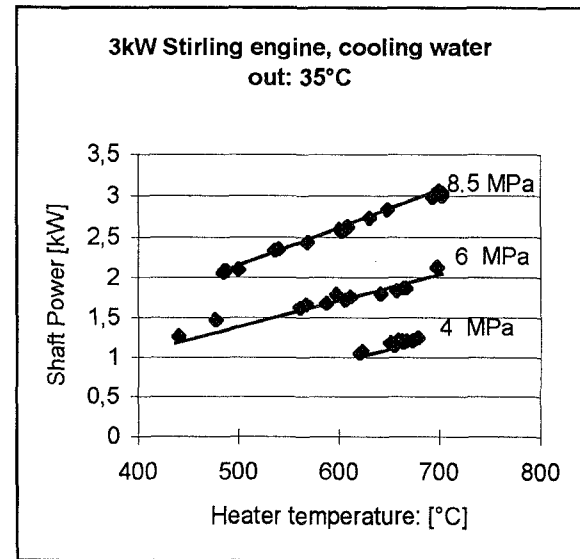

FIG. 5 Shaft power versus heater temperature at different pressures.

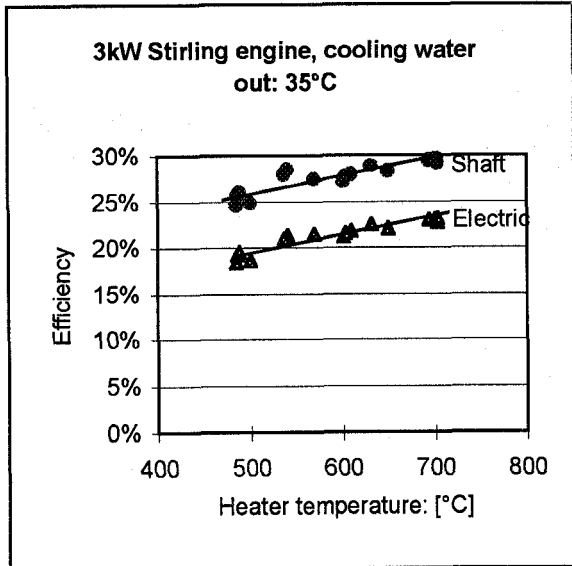

FIG. 6 Efficiency versus heater temperature at mean pressure 8.5 MPa.

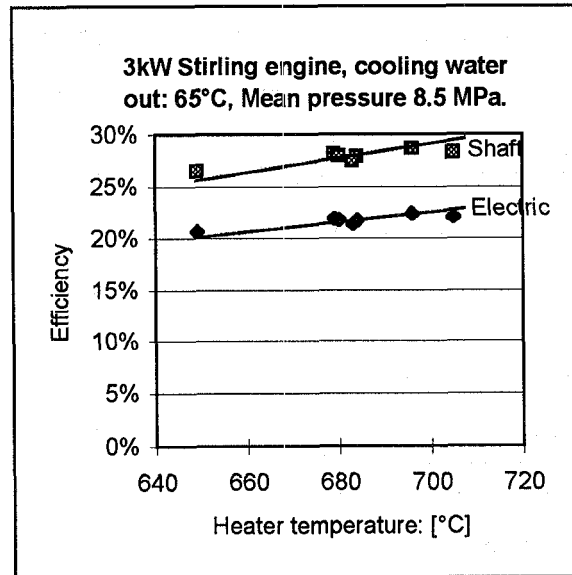

FIG. 8. Efficiency at elevated cooling temperature.

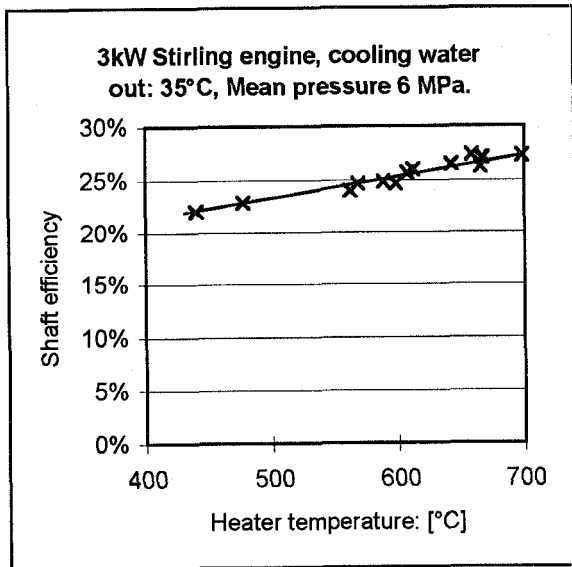

FIG. 7 Shaft efficiency of 6 MPa mean pressure.

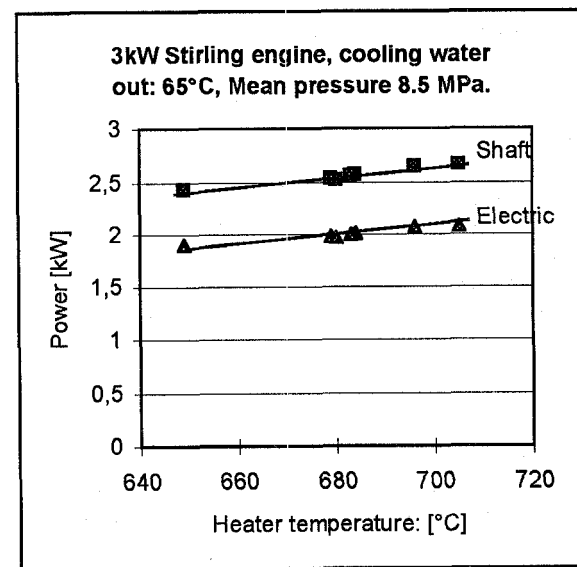

FIG. 9. Power at elevated cooling temperature.

HEAT BALANCE

Running with high temperatures and 8.5 MPa mean pressure, 9 kW of natural gas is supplied. 2.3 kW electric power is produced, and 6.2 kW of heat is recovered in the cooling water. The loss is approximate 0.5 kW. The flow rate in the cooling system is 0.53 m³/h, corresponding to a temperature raise of 10°C. The 6 kW heat supplied to the cooling system is distributed as 4.6 kW from the Stirling process, 0.6 kW from the alternator cooling, and 1 kW from the heater jacket. The exhaust gas is partly condensing.

EMISSIONS

The exhaust gas from the engine at full load has been analyzed. The results can be seen in table 2. Air / fuel ratio was 1.26. The results show very small amounts of CH_x and the level of NO_x and CO are low compared to internal combustion engines. However, the NO_x and CO emissions are high compared to modern natural gas boilers, and the burner system can be improved considerably.

Table 2. Emission from the combustion system at full engine load. Air / fuel ratio is 1.26.

CH _x	: 3 ppm
NO _x	: 180 ppm
CO	: 180 ppm
CO ₂	: 10 %
O ₂	: 3.5 %

CONCLUSION

A kinematic 3 kW Stirling engine has been designed, manufactured and tested. The engine, which is based on components from a Vuilleumier heat pump, is designed as a hermetic unit with the alternator incorporated in the pressurized crank casing. A new crank mechanism eliminating the need for cross heads has been used with good results.

The engine has been tested at different load conditions. Heater temperature and mean pressure were limited to 973 K and 9 MPa respectively. The shaft power at maximum pressure and temperature was 3 kW and the shaft efficiency was 30 % corresponding to an electrical efficiency of 23 %, as the efficiency of the alternator was found to be poor.

The hermetic design has many advantages as low leak of working gas, low frictional losses and wear in shaft seals and potential for low demands of service.

ACKNOWLEDGMENTS

The project has been supported by NESAs and Danish Gas Center (DGC). NESAs is the distributor of electric power in some regions of Denmark and DGC is a center for gas combustion research and technology.

REFERENCES

Carlsen, H. "Development of a Gas Fired Vuilleumier Heat Pump for Residential Heating", Proc. 24th IECEC, Washington D.C. 1989, Vol. 5 no 899175.

Ross, A. "The inverted yoke drive Stirling engine" Ross Experimental, Inc. Columbus, OH. IECEC 1985, Vol. III, p.3224.

Carlsen, H "Operating Experience With 10 kW Hermetic Stirling Engine". 29th IECEC 1994 vol. 4

Norton R. L. "Design of Machinery", McGraw Hill Inc. 1992