

Technical University of Denmark



Tunable dispersion compensation using phase modulation in receiver part

Siahlo, Andrei; Clausen, Anders; Oxenløwe, Leif Katsuo; Seoane, Jorge; Xu, Zhenbo; Jeppesen, Palle; Le, Nghi Trong Quang

Published in:
Technical Digest Optical Fiber Communication Conference 2004

Publication date:
2004

Document Version
Publisher's PDF, also known as Version of record

[Link back to DTU Orbit](#)

Citation (APA):
Siahlo, A., Clausen, A., Oxenløwe, L. K., Seoane, J., Zhenbo, X., Jeppesen, P., & Le, N. T. Q. (2004). Tunable dispersion compensation using phase modulation in receiver part. In Technical Digest Optical Fiber Communication Conference 2004 (pp. ThU4). USA: IEEE.

DTU Library

Technical Information Center of Denmark

General rights

Copyright and moral rights for the publications made accessible in the public portal are retained by the authors and/or other copyright owners and it is a condition of accessing publications that users recognise and abide by the legal requirements associated with these rights.

- Users may download and print one copy of any publication from the public portal for the purpose of private study or research.
- You may not further distribute the material or use it for any profit-making activity or commercial gain
- You may freely distribute the URL identifying the publication in the public portal

If you believe that this document breaches copyright please contact us providing details, and we will remove access to the work immediately and investigate your claim.

Tunable dispersion compensation using phase modulation in receiver part

A.I. Siahlo, A.T. Clausen, L.K. Oxenløwe, J. Seoane, Z. Xu and P. Jeppesen

COM Center, Technical University of Denmark, DTU-Building 345V, DK-2800 Lyngby, Denmark

Phone: +45 45253784, Fax: +45 45936581, E-mail: ans@com.dtu.dk

Q. N.T. Le

OFC Fitel Denmark I/S, Priorparken 680, DK-2605 Brøndby, Denmark

Abstract: A novel method of tuneable dispersion compensation at which phase modulation is applied in the receiver part is proposed for OTDM systems. Compensation of dispersion of 3.2 ps/nm at 160 Gb/s OTDM transmission is demonstrated.

©2003 Optical Society of America

OCIS codes: (060.4510) Optical communications (060.2360) Fiber optics links and subsystems

1. Introduction

As the channel rate in communication systems increases, the tolerances for dispersion are strongly reduced. Some transmission experiments at bit rates of 160 Gb/s have been demonstrated using carefully designed transmission lines with accumulated dispersion less than 1.2 ps/nm [1]. The maximum demonstrated tolerable accumulated dispersion for successful demultiplexing from 160 Gb/s of 2 ps/nm was demonstrated [2]. Since the dispersion of transmission system can be changed due to temperature changes [3,4], network reconfiguration, wavelength changes and other factors, tunable dispersion compensating is required. Detection of dispersion in transmission system is possible by monitoring, for example, intensity of timing frequency components [5]. Chirped fiber grating can be used for tunable compensation of dispersion and slope at 160 Gb/s [6], but it requires complex fabrication method and it has limited bandwidth. Dispersion and slope can be compensated by tunable pre-chirping using cosinusoidal phase modulation of the input pulses [2,7]; an increase in tolerance of accumulated dispersion to 4 ps/nm in system using pre-chirping was demonstrated [2]. Compensation by pre-chirping is convenient, because it is simple, does not depend on wavelength, and does not need an advanced fabrication method. Ideally, however, pre-chirping subsystem should be placed at the beginning of a transmission span to apply the right chirp to pulses before transmission. As the tunable pre-chirping is situated in the transmitter, dynamic control of it would require control signal transmitted from the system receiver to the system transmitter, introducing a substantial complexity to the setup.

In the present work we show that cosinusoidal phase modulation used for dispersion compensation can be placed after transmission, i.e., in the receiver part. First we explain the possibility of using phase modulation for post compensation. Then we demonstrate successful demultiplexing from 160 to 10 Gb/s of a system with a dispersion of 3.2 ps/nm using the mentioned post-compensation.

2. Principle of post-compensation by phase modulation

The purpose of dynamic dispersion compensation in OTDM system is to maintain the pulse width after transmission if dispersion of the system is changed in order to avoid overlapping of pulses of neighboring channels. A dispersion compensating subsystem (DCS) used for pre-chirping in [2,7] consists of two dispersive fibers with opposite sign of dispersion and a phase modulator (PM) in between; adjusting the amplitude of the phase modulation in the DCS changes the pulse width after transmission [2]. Similarly adjusting the amplitude of the PM can change the pulsewidth if the DCS is placed after transmission. Since the bit-rate of the OTDM signal (160 Gb/s) exceeds the repetition rate of the control signal applied to PM (10 GHz), the cosinusoidal phase modulation used to compensate for pulse broadening is optimized only for one OTDM channel. However, the difference between the phase of the control signal to the PM for nearest channels is small ($2\pi/16$), therefore a number of channels will be compensated. Thus, post-compensation by phase modulation can eliminate overlapping between the pulses of the target channel and the nearest neighboring channels.

Figure 1 shows results of simple modeling of using of DCS after transmission for dispersion compensation at 160 Gb/s. We used the same dispersions of the fibers in DCS, the same amplitude of phase modulation and the same width of the pulses of OTDM signal as in subsequent experiment. The eye-diagram shows number of not-overlapped channels.

(a)

(b)

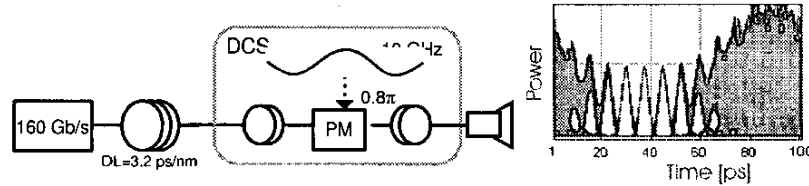

Figure 1. (a) Principle of operation of post-compensation using phase modulation and (b) eye-diagram of 160 Gb/s signal after DCS obtained by simulations

3. Experimental results

Experimental setup used to confirm the possibility of dispersion post-compensation using a PCU is shown in figure 2.

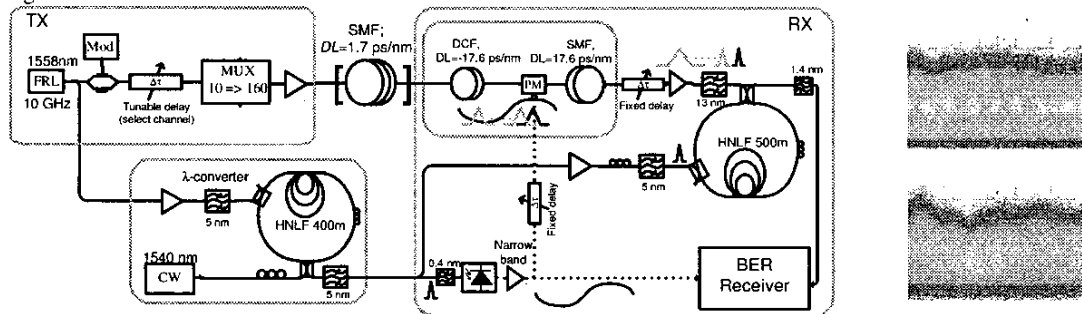

Figure 2. Experimental setup (left); eye-diagram of the 160 Gb/s signal at the input to the demultiplexing NOLM without (right, top) and with (right, bottom) extra SMF (PM in DCS is off).

In the transmitter part (TX) the mode-locked fibre-ring laser (FRL) operating at a wavelength of 1558 nm generates short pulses with FWHM of 3.0 ps at 10 GHz. The pulse train is data modulated with a 2^7-1 to $2^{31}-1$ PRBS sequence in a LiNbO₃ MZ modulator. The 10 Gb/s signal is multiplexed to 160 Gb/s by a fiber-delay multiplexer maintaining the properties of the 2^7-1 PRBS (kindly provided by HHI Institute, Berlin).

The receiver part (RX) includes the DCS, the nonlinear optical loop mirror (NOLM) as a demultiplexer [8], and a preamplified 10 Gb/s receiver with BER analyzer. The DCS includes a DCF with accumulated dispersion of - 17.6 ps/nm, a PM and a SMF with accumulated dispersion of + 17.6 ps/nm. Wavelength-converted to 1540 nm by another NOLM, pulses from the FRL are applied as the control signal to the demultiplexing NOLM. The control signal is also o/e converted and amplified by a narrow-band electrical amplifier to obtain cosinusoidal RF signal. This cosinusoidal RF signal is applied to the PM in the DCS and as a clock to BER analyzer. Both NOLMs contain HNLFs with very low dispersion (less than 0.2 ps/nm at operating wavelengths) and dispersion slope. Lengths of the HNLFs are 400 m and 500 m. Due to the low dispersion of the HNLF in the demultiplexing NOLM walk-off between control and data signals and pulse broadening of the two are negligible. The two time delays in the RX part serve to synchronize control signals to the PM and to NOLM and data signal. These time delays were optimized when only one OTDM channel is injected into the NOLM.

The system was evaluated without and with an extra SMF fiber having accumulated dispersion of 1.7 ps/nm. Autocorrelation traces of the 160 Gb/s signal injected into the NOLM are shown in figure 3. Without extra SMF the pulses of the data signal are broadened to 3.5 ps before injecting in the demultiplexing NOLM. This broadening occurs due to the internal dispersion of the setup of 1.5 ps/nm. The eye diagram of the 160 Gb/s signal based on 3.5 ps pulses is shown in figure 2, top-right. The structure of the OTDM signal on eye-diagram and pulses of different channels on autocorrelation traces can be seen.

With the extra SMF fiber dispersion of the system becomes 3.2 ps/nm and the pulses are broaden to 4.75 ps at the input to the NOLM. The eye-diagram of OTDM signal is more diffused (figure 2, right-bottom) and OTDM structure cannot be seen on autocorrelation trace. When the phase modulation with amplitude of 0.8π is applied in the setup with an additional fiber, the width of the pulses of one OTDM channel, demultiplexing by the NOLM, becomes 3.5 ps again; however, the structure of OTDM signal on autocorrelator cannot be seen because only one of 16 channels has narrow pulsewidth.

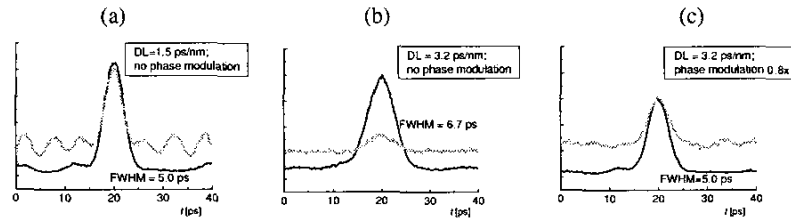

Figure 3. Autocorrelation traces of the signal at the input to the demultiplexing NOLM. Black lines: only one channel is transmitted through the system; grey lines: multiplexed signal. (a) Setup without an extra fiber; (b) setup with the extra SMF fiber; total accumulated dispersion of the setup is 3.2 ps/nm; (c) total accumulated dispersion of the setup is 3.2 ps/nm and post-compensation is used.

Figure 4 shows results for demultiplexing of the signal sent to the RX without extra SMF fiber ($DL = 1.5$ ps/nm) and with extra SMF ($DL = 3.2$ ps/nm). Error-free ($1E-9$) operation can be reached when $DL = 1.5$ ps/nm. The minimum value of the BER of $1E-7$ can be reached with the extra SMF. Applying phase modulation improves the performance and an error-free operation can be reached with penalty of 2 dB. The BER-curves in figure 4 are given for the same OTDM channel with and without an extra SMF; however, all OTDM channels gave error-free demultiplexing without an extra SMF and with an extra SMF and post-compensation.

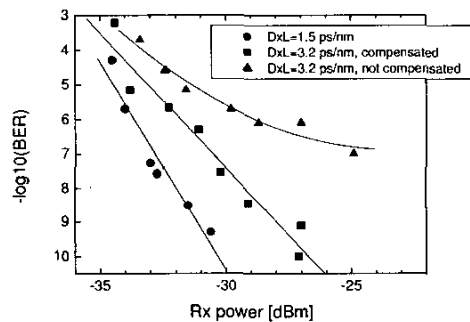

Figure 4. BER curves for demultiplexing of the signal sent to RX without an extra fiber ($DL = 1.5$ ps/nm) and with the extra SMF ($DL=3.2$ ps/nm) with and without post-compensation by the PCU.

4. Conclusion

In this paper we have for the first time proposed and demonstrated tunable dispersion post-compensation for 160 Gb/s by phase modulation. The performance of the transmission and demultiplexing was found to be error free for the dispersion of the system of 3.2 ps/nm.

5. References

1. R. Ludvig et al, "Enabling transmission at 160 Gbit/s", OFC'02 (2002), paper TuA1
2. A. Siahlo et al, "Using a phase modulator for improvement of the tolerance to second-order dispersion in a 160 Gb/s transmission system", ECOC'03 (2003), paper Tu 4.7.2
3. T.Kato et al, "Temperature dependence of chromatic dispersion in various types of optical fibers", OFC'00 (2000), 1, pp.104-106
4. J. Rathje and M. Andersen, "Temperature Induced Change in the Dispersion Spectrum of Dispersion Compensating Fibers", OFC'03 (2003), paper FK1
5. G. Ishikawa and H. Ooi, "Demonstration of automatic dispersion equalization in 40 Gbit/s OTDM transmission", ECOC'98 (1998), 1, pp.519-520
6. S. Wakabayashi et al, "Tunable Dispersion Slope Compensator Based on Chirped FBGs with Temperature Distribution for 160 Gbit/s", OFC'03 (2003), paper MF27
7. E. Hellström et al, "Evaluation of third order dispersion compensation by phase modulation for 160 Gb/s RZ data using an all-optical sampling system", ECOC'02 (2002), paper 6.1.5
8. L.K. Oxenløwe et al., "A photonic crystal fibre used as a 160 to 10 Gb/s demultiplexer", OECC'02 (2002), paper PD-1-4