

Technical University of Denmark



## Experimental investigation at 10 Gb/s of the noise suppression capabilities in a pass-through configuration in SOA-based interferometric structures

**Wolfson, David; Fjelde, Tina; Kloch, Allan; Janz, C.; Coquelin, A.; Guillemot, I.; Gaborit, F.; Poingt, F.; Renaud, M.**

*Published in:*

I E E E Photonics Technology Letters

*Link to article, DOI:*

[10.1109/68.853517](https://doi.org/10.1109/68.853517)

*Publication date:*

2000

*Document Version*

Publisher's PDF, also known as Version of record

[Link back to DTU Orbit](#)

*Citation (APA):*

Wolfson, D., Fjelde, T., Kloch, A., Janz, C., Coquelin, A., Guillemot, I., ... Renaud, M. (2000). Experimental investigation at 10 Gb/s of the noise suppression capabilities in a pass-through configuration in SOA-based interferometric structures. I E E E Photonics Technology Letters, 12(7), 837-839. DOI: 10.1109/68.853517

## DTU Library

Technical Information Center of Denmark

---

### General rights

Copyright and moral rights for the publications made accessible in the public portal are retained by the authors and/or other copyright owners and it is a condition of accessing publications that users recognise and abide by the legal requirements associated with these rights.

- Users may download and print one copy of any publication from the public portal for the purpose of private study or research.
- You may not further distribute the material or use it for any profit-making activity or commercial gain
- You may freely distribute the URL identifying the publication in the public portal

If you believe that this document breaches copyright please contact us providing details, and we will remove access to the work immediately and investigate your claim.

# Experimental Investigation at 10 Gb/s of the Noise Suppression Capabilities in a Pass-Through Configuration in SOA-Based Interferometric Structures

D. Wolfson, T. Fjelde, A. Kloch, C. Janz, A. Coquelin, I. Guillemot, F. Gaborit, F. Poingt, and M. Renaud

**Abstract**—We experimentally investigate a pass-through scheme for all-optical noise suppression in an SOA-based interferometric structure at 10 Gb/s. An input power dynamic range of  $\sim 8$  dB as well as a noise suppression capability of  $\sim 4.5$  dB has been demonstrated. Furthermore, the transmission properties have been investigated showing a small pre-amplified penalty of  $\sim 0.3$  dB after transmission over 31 km of standard single mode fiber.

**Index Terms**—All-optical regeneration, amplifier noise, converters, high-speed optical techniques, semiconductor optical amplifiers.

## I. INTRODUCTION

**F**UTURE high-speed optical networks will need all-optical regeneration in order to suppress signal degradations induced by accumulation of noise, jitter and dispersion, which otherwise would severely limit the network size. Several techniques for all-optical 2R and 3R regeneration have been investigated, however the most promising results have been achieved with SOA-based interferometric wavelength converters (IWC) [1], [2]. Still, in most of the schemes reported so far, the regeneration has been performed with simultaneous wavelength conversion at the expense of an increased complexity, i.e., a CW laser as well as an optical filter at the output of the converter is needed. In a novel approach [3], all-optical 2R regeneration can be achieved in an SOA-based interferometric structure using only the data signal, thereby making the scheme very simple and competitive in parts of the optical network, where wavelength conversion is not needed. Additionally, this regeneration scheme has been shown feasible at 40 Gb/s [4].

Here, we experimentally investigate the noise suppression capabilities as well as the transmission performance of an SOA-based interferometer used in the pass-through configuration at 10 Gb/s. A high input power dynamic range, excellent noise suppression capabilities as well as good transmission properties illustrate the good performance of the pass-through scheme.

Manuscript received November 9, 1999; revised March 27, 2000. This work was supported in part by the European research program ACTS, REPEAT.

D. Wolfson, T. Fjelde, and A. Kloch are with Research Center COM, Technical University of Denmark, Lyngby, Denmark; (e-mail: dw@com.dtu.dk).

C. Janz, A. Coquelin, I. Guillemot, F. Gaborit, F. Poingt, and M. Renaud are with OPTO+, Groupement d'Intérêt Economique, Alcatel Corporate Research Center, Marcoussis, France (e-mail: Christopher.Janz@ms.alcatel.fr).

Publisher Item Identifier S 1041-1135(00)05826-2.

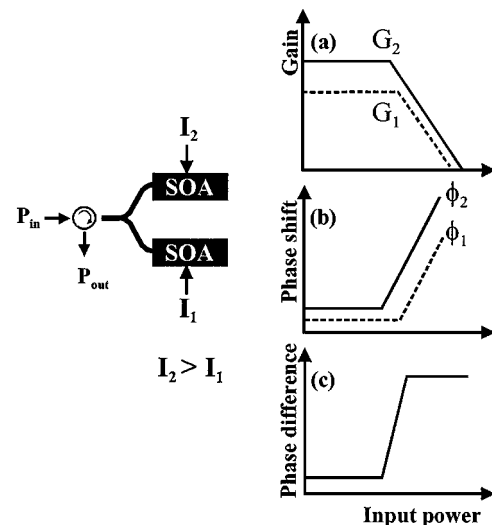

Fig. 1. Principle of the pass-through regeneration scheme. (Left) schematic of an SOA-based interferometric structure biased at  $I_1$  and  $I_2$  on the lower and upper interferometer arm, respectively. It is assumed that  $I_2$  is larger than  $I_1$ . (Right) (a) and (b) shows the gain ( $G_1, G_2$ ) and phase shift ( $\phi_1, \phi_2$ ) in the lower and upper interferometer arm, respectively, whereas (c) shows the resulting phase difference a signal would experience in the interferometer.

## II. PRINCIPLE OF THE PASS-THROUGH SCHEME

In Fig. 1 the principle of the regeneration scheme is illustrated. As shown in the figure an SOA-based Michelson interferometer (MI) is biased at  $I_1$  and  $I_2$  in the lower and upper interferometer arm, respectively. In the pass-through configuration an input signal is injected into the interferometer, where it splits equally in the upper and lower interferometer arm and after traversing the interferometer arms, the signal is reflected at the end facet after which it propagates in the opposite direction. Finally, the signal recombines at the input, either constructively or destructively depending on the phase difference between the interferometer arms. This phase difference is achieved by asymmetric biasing of the interferometer arms. In the following, it is assumed that  $I_2$  is larger than  $I_1$ . Since a higher bias current is applied to the upper interferometer arm, this will result in a higher gain and a lower saturation input power compared to the lower interferometer arm [see Fig. 1(a)]. Consequently, as seen in Fig. 1(b), the phase shift in the upper interferometer arm will start to increase at a lower input power than in the lower interferometer arm resulting in a total phase difference close to that

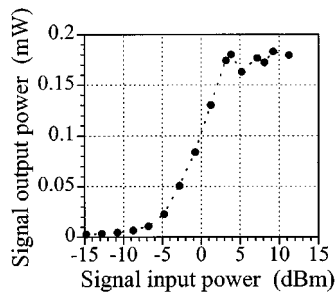

Fig. 2. Measured signal output power as a function of the input power. The signal wavelength is 1550 nm.

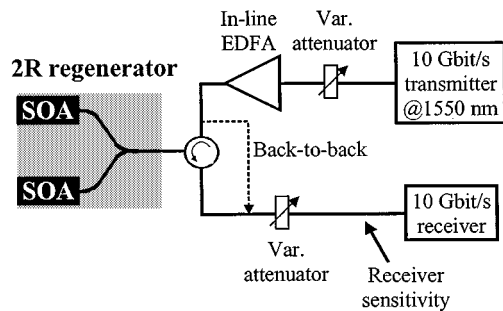

Fig. 3. Experimental setup for 2R regeneration using the pass-through scheme at 10 Gb/s. The dashed line indicates the back-to-back setup.

of an decision gate [Fig. 1(c)]. Therefore, the same will apply to the transfer function of the input power. This is shown in Fig. 2 giving the measured output power from the MI as a function of the input power [3]. As can be seen, the transfer function for this regeneration scheme is close to that of a decision gate. We note that this is in contrast to the sinusoidal transfer function obtained from a Michelson interferometer performing wavelength conversion. It should also be mentioned, though, that since there is a different gain in the interferometer arms, the destructive interference at low input powers will not be perfect, why the reshaping capabilities will be better for a logical “1” than for a logical “0.” In Fig. 1, an MI is shown; however, it is emphasized that the principle is the same for a Mach-Zehnder interferometer (MZI).

### III. EXPERIMENTAL SETUP

The experimental setup is shown in Fig. 3. The data signal at 10 Gb/s (PRBS =  $2^7 - 1$ ) with a wavelength of 1550 nm (NRZ format) is first transmitted through an inline EDFA. Here, the attenuator before the EDFA controls the input power by which the signal-to-ASE ratio at the input of the MI can be controlled. The signal is then coupled into the MI, where it splits equally in the interferometer arms. After traversing the interferometer arms, the signal is reflected at the end facet. Finally, the signal recombines at the input, either constructively or destructively depending on the phase difference between the interferometer arms as explained above. The optical circulator separates the output signal from the input signal before final detection. It is emphasised that no filter is applied at the output of the MI, i.e., no additional ASE filtering is performed compared to back-to-back.

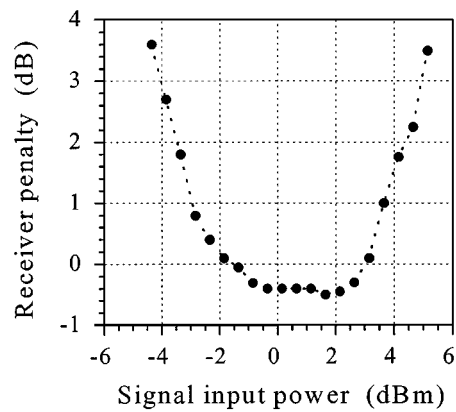

Fig. 4. Receiver penalty as a function of the signal input power to the Michelson interferometer at 10 Gb/s. The wavelength is 1550 nm, and the input power to the EDFA is 0 dBm.

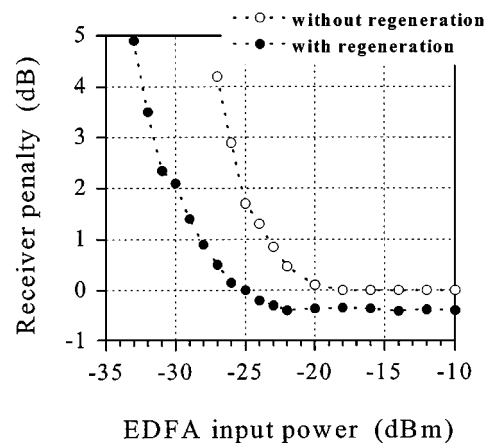

Fig. 5. Receiver penalty as a function of the EDFA input power with and without regeneration in a Michelson interferometer. The bit rate is 10 Gb/s, and the wavelength is 1550 nm.

### IV. RESULTS AND DISCUSSION

An important benefit coming from the fact that the transfer function of the pass-through scheme is close to that of an decision gate, is a large input power dynamic range (IPDR). This is demonstrated in Fig. 4, showing the receiver penalty as a function of the input power to the MI. We note, that penalty free operation is achieved over a range of  $\sim 4.5$  dB, whereas the IPDR is  $\sim 8$  dB [ $\sim 2$  dB of preamplified penalty]. The noise suppression capabilities of the MI are demonstrated in Fig. 5 showing the receiver penalty with and without regeneration as a function of the in-line EDFA input power. Clearly, the input signal is regenerated in the MI and very good noise suppression performance is achieved. As demonstrated, a  $\sim 4.5$ -dB lower input power to the EDFA is allowed by applying the MI [ $\sim 2$  dB penalty].

An important issue for practical use of all-optical regenerators is the transmission performance of regenerated signals. Interferometric structures performing wavelength conversion have a 2R regeneration capability but in order to obtain a high conversion speed, out-of-phase operation is preferable, i.e., the converted signal is inverted compared to the input signal. However, the transmission distance of out-of-phase converted signals is limited due to the chirped output signal [5]. The pass-through scheme has been proven to be feasible at high bit rates, i.e.,

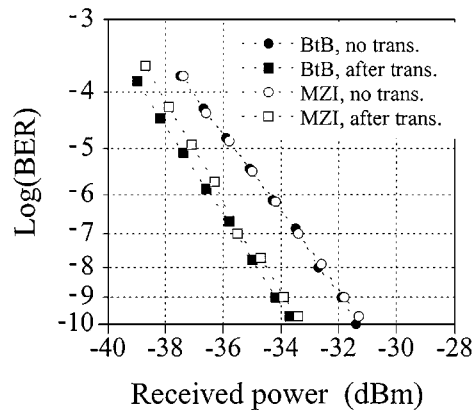

Fig. 6. BER as a function of the received power for back-to-back and after a MZI in the pass-through scheme, both before and after 31-km standard single-mode fiber. The bit rate is 10 Gb/s and the wavelength is 1550 nm.

40-Gb/s 2R regeneration has been reported [4]. Additionally, the transmission properties are good due to in-phase operation (see Fig. 2). In order to verify the latter, Fig. 6 shows the BER as a function of the received power for back-to-back and the regenerated signal after transmission over 31 km of standard single mode fiber (BER measurements before transmission are also included in the figure). We note that the input signal to the regenerator in this case is taken directly from the transmitter. In this experiment a MZI was used, however, it is emphasised that the chirp characteristics of a MI and a MZI are similar when modulated in the same fashion. Therefore, the results also apply for the pass-through scheme when using a MI. As seen, traversing the MZI and transmitting 31 km results in a preamplified penalty of only  $\sim 0.3$  dB. We note that the reason for the improved sensitivities after transmission compared to the case without trans-

mission is only due to the chirp added by the electro-optical  $\text{LiNbO}_2$  modulator used in the transmitter, which results in a pulse compression after transmission.

## V. CONCLUSION

A pass-through scheme for all-optical 2R regeneration in an SOA-based interferometric structure has been investigated experimentally at 10 Gb/s. An input power dynamic range of  $\sim 8$  dB as well as a noise suppression capability of  $\sim 4.5$  dB has been demonstrated in a Michelson interferometer. Furthermore, the transmission properties have been investigated showing a small preamplified penalty of  $\sim 0.3$  dB after transmission over 31 km of standard single-mode fiber. Therefore, taking the simplicity of the regeneration scheme as well as the good performance into account, this approach is a feasible and competitive technique, where wavelength conversion is not needed.

## REFERENCES

- [1] B. Lavigne, D. Chiaroni, L. Hamon, C. Janz, and A. Jourdan, "Experimental analysis of SOA based 2R and 3R optical regeneration for future WDM networks," in *Tech. Dig. OFC*, San Jose, CA, paper Th07, 1998.
- [2] B. Lavigne, D. Chiaroni, P. Guerber, L. Hamon, and A. Jourdan, "Improvement of regeneration capabilities in semiconductor optical amplifier-based 3R regenerator," in *Tech. Dig. OFC*, San Diego, CA, paper TuJ3, 1999.
- [3] D. Wolfson, P. B. Hansen, A. Kloch, and K. E. Stubkjaer, "All-optical 2R regeneration based on interferometric structure incorporating semiconductor optical amplifiers," *Electron. Lett.*, vol. 35, no. 1, pp. 59–60, 1999.
- [4] D. Wolfson, P. Hansen, A. Kloch, T. Fjelde, C. Janz, A. Coquelin, I. Guillemot, F. Gaborit, F. Poingt, and M. Renaud, "All-optical 2R regeneration at 40 Gbit/s in an SOA-based Mach-Zehnder interferometer," in *Tech. Dig. OFC*, San Diego, CA, paper PD36, 1999.
- [5] T. Durhuus, B. Mikkelsen, C. Joergensen, S. L. Danielsen, and K. E. Stubkjaer, "All-optical wavelength conversion by semiconductor optical amplifiers," *J. Lightwave Technol.*, vol. 13, pp. 942–954, June 1996.