

Technical University of Denmark



## 8x40 Gb/s 55-km WDM transmission over conventional fiber using a new RZ optical source

Yu, Jianjun; Zheng, Xueyan; Liu, Fenghai; Peucheret, Christophe; Jeppesen, Palle

*Published in:*  
I E E Photonics Technology Letters

*Link to article, DOI:*  
[10.1109/68.853550](https://doi.org/10.1109/68.853550)

*Publication date:*  
2000

*Document Version*  
Publisher's PDF, also known as Version of record

[Link back to DTU Orbit](#)

*Citation (APA):*  
Yu, J., Zheng, X., Liu, F., Peucheret, C., & Jeppesen, P. (2000). 8x40 Gb/s 55-km WDM transmission over conventional fiber using a new RZ optical source. I E E Photonics Technology Letters, 12(7), 912-914. DOI: 10.1109/68.853550

## DTU Library

Technical Information Center of Denmark

---

### General rights

Copyright and moral rights for the publications made accessible in the public portal are retained by the authors and/or other copyright owners and it is a condition of accessing publications that users recognise and abide by the legal requirements associated with these rights.

- Users may download and print one copy of any publication from the public portal for the purpose of private study or research.
- You may not further distribute the material or use it for any profit-making activity or commercial gain
- You may freely distribute the URL identifying the publication in the public portal

If you believe that this document breaches copyright please contact us providing details, and we will remove access to the work immediately and investigate your claim.

# 8 × 40 Gb/s 55-km WDM Transmission over Conventional Fiber Using a New RZ Optical Source

Jianjun Yu, Xueyan Zheng, Fenghai Liu, *Student Member, IEEE*, Christophe Peucheret, Anders T. Clausen, Henrik N. Poulsen, and Palle Jeppesen

**Abstract**—A multiwavelength RZ optical source with equal amplitudes and pulsewidths is successfully obtained by using wavelength conversion in a nonlinear optical loop mirror consisting of a common dispersion shifted fiber. The converted wavelengths of the eight signal pulses are in agreement with the ITU-T proposal and a commercial arrayed-waveguide grating is used for demultiplexing in the frequency-domain. By using the new source 8 × 40 Gb/s WDM transmission over 55 km conventional fiber was realized.

**Index Terms**—Multiplexing, nonlinear optical loop mirror, optical demultiplexing, optical time-division, wavelength conversion, wavelength-division multiplexing.

## I. INTRODUCTION

**B**ROAD-BAND low-noise optical sources are of a vital importance for future large-capacity flexible optical network utilization of both optical time-division multiplexing (OTDM) and wavelength-division multiplexing (WDM) [1]. It is an effective method to generate short pulses by using the supercontinuum method, but a dispersion-flattened fiber for generating the supercontinuum and a special WDM filter for filtering the channels will be needed [1]. In this letter, the RZ pulses at eight wavelengths were realized by using wavelength conversion in a nonlinear optical loop mirror (NOLM) consisting of a common DSF. The converted wavelengths of the eight signal pulses are in agreement with the ITU-T proposal and a commercial arrayed-waveguide grating (AWG) is used to realize demultiplexing in the frequency-domain. The converted pulses at the different wavelengths have nearly equal widths and amplitudes. By using the new source 8 × 40 Gb/s WDM transmission over 55 km conventional fiber was realized.

## II. EXPERIMENTS AND RESULTS

The experimental setup is shown in Fig. 1. The outputs of eight commercial distributed feedback (DFB) lasers are combined in a commercial AWG having a wavelength spacing of 1.6 nm. These lasers operate at the ITU-standardized wavelength proposal. The operating wavelengths are 1549.31 nm ( $\lambda_1$ ), 1550.90 nm ( $\lambda_2$ ), 1552.52 nm ( $\lambda_3$ ), 1554.12 nm ( $\lambda_4$ ), 1555.72 nm ( $\lambda_5$ ), 1557.33 nm ( $\lambda_6$ ), 1558.96 nm ( $\lambda_7$ ) and 1560.60 nm ( $\lambda_8$ ). The combined signals of the eight channels were amplified to an average power of 18 dBm, and injected into the NOLM from Port 1. The control laser is a 10 GHz,

1546.8 nm ( $\lambda_0$ ) gain-switched DFB LD that generates 9.1 ps (FWHM) pulses after compression in a dispersion compensated fiber (DCF). The RZ pulses at eight wavelengths were realized simultaneously by using wavelength conversion in the NOLM. The lengths of the DSF's in the NOLM's for wavelength conversion (WC-NOLM) and demultiplexing (D-NOLM) are both 3 km. We measured the characteristics of the DSF's. The results show that the zero dispersion wavelengths of the DSF's in WC-NOLM and D-NOLM are 1550.7 and 1555.0 nm, respectively; the dispersion slopes of the DSF's are both 0.08 ps/nm/km, and the fibers are common DSF's. Fig. 2 shows the pulse FWHM filtered out from the converted output pulses using another commercial AWG. The optical spectrum from Port 2 after wavelength conversion is shown in inset (a) of Fig. 3. Equal amplitudes and nearly equal pulsewidths at different wavelengths are obtained. The pulsewidth of the converted pulse is narrower than that of the control pulse. After adding the LiNbO<sub>3</sub> modulator, and modulating the optical pulses with a pseudorandom bit sequence (PRBS) of length  $2^{31} - 1$ , bit-error rates (BER's) of the eight 10 Gb/s channels were measured. The BER curves (Fig. 3) show no error floors and the measured power penalties for BER < 10<sup>-9</sup> are all within 4 dB. The power penalties are mainly attributed to reduced signal to noise ratio (SNR), and the un-flattened gain of EDFA leads to different penalties of different channels. Increasing the input power of the CW light into the NOLM is beneficial for SNR improvement of the converted signal, and for reducing the power penalty. Our experiment has shown that the power penalty is very small and even negative when only one-channel CW light with an average power of 14 dBm is used [2].

We now modulate the control pulses using a  $2^7 - 1$  PRBS. Then the converted signals are multiplexed to 40 Gb/s by using optical delay lines. We use an optical notch filter (ONF) with free spectrum range (FSR) of 15 nm to suppress the control signal. The FSR is a little narrow, so some channels are also suppressed, which can be seen from inset (a) in Fig. 4, and consequently the BER of these channels will be affected. The OTDM-WDM signals were then amplified to 12 dBm in average power by an EDFA, they were compensated by 4.8 km DCF after transmission through 30-km single-mode fiber (SMF), then amplified to 12 dBm again, and transmitted through another 25-km SMF and 3.6-km DCF. No effort was made to optimize the order of SMF's and DCF's. The average dispersion of the whole fiber span is 0.3 ps/nm/km. The output signals were filtered by another commercial AWG. All optical demultiplexing from 40 to 10 Gb/s was realized

Manuscript received September 7, 1999; revised February 4, 2000.

The authors are with Research Center COM, Technical University of Denmark, Lyngby DK-2800, Denmark (e-mail: jy@com.dtu.dk).

Publisher Item Identifier S 1041-1135(00)05828-6.

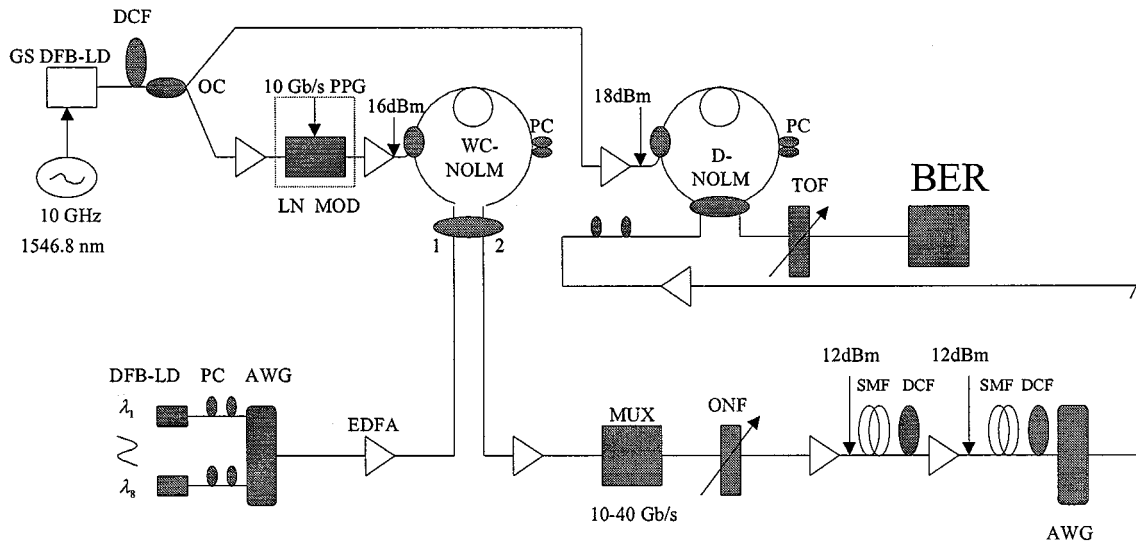

Fig. 1. Experimental setup.

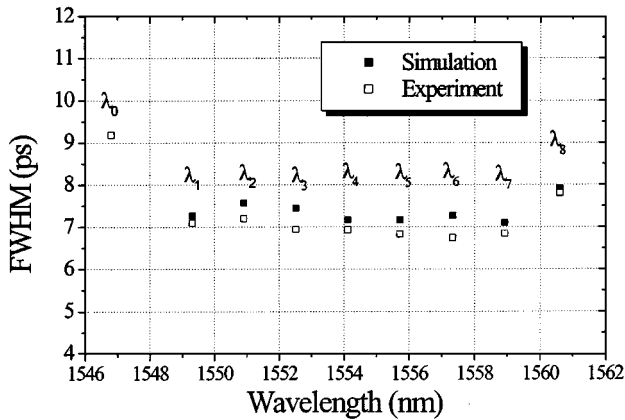

Fig. 2. Pulse FWHM for experiment and numerical simulation at eight wavelengths.

in the time-domain by another NOLM. The demultiplexed 10-Gb/s signal was detected by an optical receiver, and BER performance was measured and is shown in Fig. 4. Here,  $\tau$  denotes the walkoff time between the 10 GHz control pulses and the 40-Gb/s OTDM signals. Channel 1 and 2 are close to the control pulses with the center wavelength 1546.8 nm; the control pulses can not be effectively suppressed by an optical filter when they are demultiplexed from 40 Gb/s to 10 Gb/s in the time-domain, hence the BER's of channel 1 and channel 2 are not measured. However, clean eye diagrams of channel 1 and 2 after transmission over 55-km SMF can be obtained. As an example, inset (b) in Fig. 4 shows the eye diagram of channel 1 after transmission and inset (c) in Fig. 4 shows the eye diagram of channel 5 after transmission and demultiplexing in the time domain. Clean eye diagrams of the OTDM signals and demultiplexed signals can be seen. From Fig. 4, comparing with the penalty of the back-to-back measurement, we can see that the power penalties are small after the optical signals have been transmitted over the fiber span. These results confirm that the kind of RZ pulse source presented here is promising as a Tb/s OTDM-WDM transmitter.

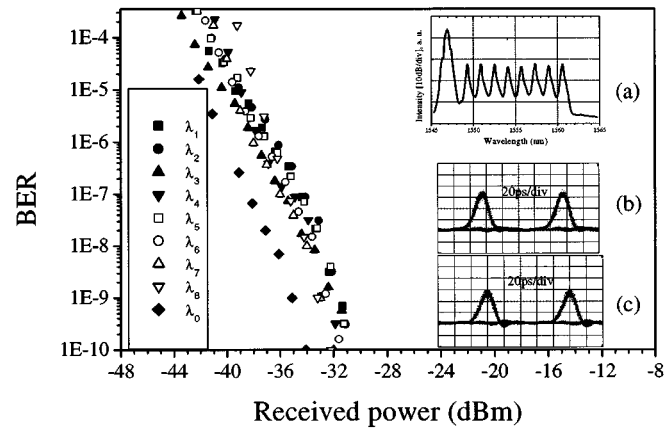

Fig. 3. BER measurements. Inset (a) shows optical spectrum of the converted WDM signals from port 2 of WC-NOLM with 0.1 nm resolution; insets (b) and (c) show eye diagrams of the control signals and converted signals of channel 8, respectively.

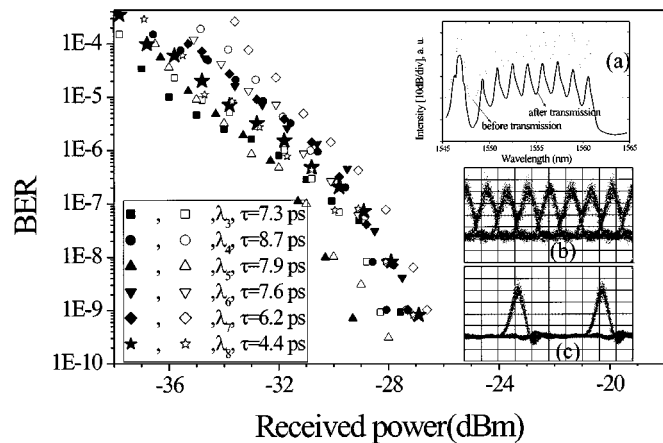

Fig. 4. BER measurements. Black solid dots and empty dots represent BER's before and after transmission, respectively. Inset (a) shows the spectrum of WDM channels before and after transmission with 0.2 nm resolution, inset (b) shows eye diagram (20 ps/div) of channel 1 after transmission, and inset (c) shows eye diagram (20 ps/div) of channel 5 after transmission and demultiplexing in the time-domain.

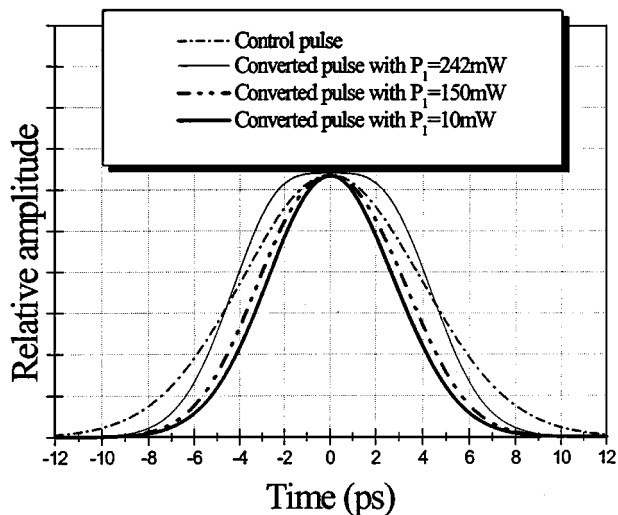

Fig. 5. Calculated pulse shapes with only XPM effect considered at different peak power of the control pulses.

### III. DISCUSSION

It is well known that fiber dispersion and walkoff between the control pulses and the CW lightwave will broaden the pulsewidths of the converted signals. But Fig. 2 shows that the pulsewidths of the converted signals are compressed. It seems that our experimental results are contrary to the theoretical expectation. We use numerical simulation and analytical methods to analyze this question. The propagation of the control pulses and the co-propagating and counter-propagating waves in the 3 km DSF is governed by the nonlinear *Schrödinger* equation, the detailed numerical model is given in [3]. The wavelength of the CW lightwave is changed from 1549.3 nm to 1560.6 nm while the average powers of co-propagating and counter-propagating CW light waves are both 4 mW. Fig. 2 displays the results of a numerical simulation. It shows that the results of the numerical simulation are in agreement with those of the experiments. Because the dispersion and walkoff time of channel 8 are a little large, the pulsewidth of the converted pulses is a little larger than that of the other channels. From Fig. 2 we can see that the pulsewidths of the converted pulses are compressed. Within the wavelength range from 1549.3 nm to 1560.6 nm, there is a small walkoff and small dispersion, so XPM is the main effect. When only XPM effect is considered, the power of the converted pulses  $P_{out}$  can be expressed by the following equation [4]:

$$P_{out} = \frac{P_2}{2} \left[ 1 - \cos \left( \beta \gamma_1 P_1 L \exp \left( -\frac{t^2}{t_c^2} \right) \right) \right]. \quad (1)$$

Here  $L$  is the length of DSF and  $P_1$  and  $P_2$  are the peak power of control pulses and the power of the CW lightwave, respectively.  $t_c$  is the pulsewidth of the control pulses which is related to the FWHM pulsewidth by  $\text{FWHM} \approx 1.665t_c$ .  $\beta$  represents the XPM parameter between the control lightwave and the DFB-LD's and it ranges from  $2/3$  to  $2$  [4]; here, we assume parallel polarization between control signal and CW lasers and hence  $\beta = 2$ .

With only XPM effect considered, Fig. 5 shows the waveforms obtained from (1). It is clearly seen that the converted

pulsewidth depends on the peak power of the control pulses. When the peak power of the control pulses is smaller than 242 mW, the converted pulses are compressed. When the peak power of the control pulses is larger than 242 mW, the converted pulses will be split and the pulsewidths will be broadened. With only XPM effect considered, the peak power of the control pulses for the conversion efficiency [5] of 1 is 242 mW. It should be pointed out that the peak power of the control pulses for conversion efficiency of 1 will be larger than 242 mW if also other effects are taken into account [5]. Because XPM effect is independent of the converted wavelengths, the pulsewidths at different converted wavelengths will be the same when only XPM effect is considered. When the wavelength of the CW lightwave is increased to 1560.6 nm, dispersion effect and walkoff effect can no longer be fully ignored. In order to obtain equal pulsewidths of the converted signals at different channels as well as we can, we can adjust the polarization controller of the DFB-LD at channel 8 and in this way change  $\beta$ . From (1), we can see that  $\beta$  can affect the pulse shape. Our experiment shows that the polarization directions of the converted signals are not completely the same; however, our modulator is sensitive to the polarization direction and we do not have eight modulators available at the same time. For these reasons, in our experiment, we place the modulator between the GS-DFB laser and the NOLM, not between the NOLM and the multiplexer.

Our experiments have shown that when the walkoff time between the control pulses (10 GHz) and the OTDM signals ( $4 \times 10$  Gb/s) is 2 ps, there is a minimal power penalty [3]. When the walkoff time is larger than the optimal value, the penalty will be increased. It is obvious that the walkoff time in our experiment is larger than the optimal value. Because of the large walkoff, when we use a pattern length of  $2^{31} - 1$  channel 3 and 4 will show an error floor at  $10^{-8}$ ; therefore, we use a pattern lengths of  $2^7 - 1$  in the experiment presented here. In order to reduce the walkoff, we use control pulses at 1560.6 nm to demultiplex the 40 Gb/s OTDM signals and in that case there is no sign of error floor up to  $10^{-10}$ .

### ACKNOWLEDGMENT

Lucent Technologies Denmark and France Telecom CNET are gratefully acknowledged for providing, respectively, the optical fibers and the gain-switched laser used in this work.

### REFERENCES

- [1] S. Kawarishi, H. Takara, K. Uchiyama, L. Shake, and K. Mori, "3 Tbit/s (160 Gbit/s  $\times$  19 ch) OTDM/WDM transmission experiment," presented at the OFC'99.
- [2] J. Yu, X. Zheng, F. Liu, A. Buxens, and P. Jeppesen, "Simultaneous realization wavelength conversion and signal regeneration using a nonlinear optical loop mirror," *Opt. Commun.*, vol. 175, pp. 173–177, 2000.
- [3] J. Yu, X. Zheng, C. Peucheret, A. T. Clausen, H. N. Poulsen, and P. Jeppesen, "40 Gb/s all-optical wavelength conversion based on a nonlinear optical loop mirror," *J. Lightwave Technol.*, to be published.
- [4] C. Kollock and U. Hempelmann, "All optical wavelength conversion of NRZ and RZ signals using a nonlinear optical loop mirror," *J. Lightwave Technol.*, vol. 15, pp. 1906–1913, Oct. 1997.
- [5] W. S. Man, H. Y. Tam, and M. S. Demokan, "Optimal loop length of a nonlinear optical loop mirror in switching solitons," *J. Lightwave Technol.*, vol. 16, pp. 100–105, Jan. 1998.