

Technical University of Denmark



## CHAOTIC DUFFING TYPE OSCILLATOR WITH INERTIAL DAMPING

**Tamaševicius, Arunas; Mykolaitis, Gytis; Kirvaitis, Raimundas; Tamaševiciute, Elena; Bumeliene, Skaidra; Lindberg, Erik**

*Published in:*

Proceedings of the 17th International Workshop on Nonlinear Dynamics of Electronic Systems

*Publication date:*

2009

*Document Version*

Publisher's PDF, also known as Version of record

[Link back to DTU Orbit](#)

*Citation (APA):*

Tamaševicius, A., Mykolaitis, G., Kirvaitis, R., Tamaševiciute, E., Bumeliene, S., & Lindberg, E. (2009). CHAOTIC DUFFING TYPE OSCILLATOR WITH INERTIAL DAMPING. In R. Stoop, & J. Joller (Eds.), Proceedings of the 17th International Workshop on Nonlinear Dynamics of Electronic Systems: NDES 09 (pp. 1-230)

## DTU Library

Technical Information Center of Denmark

---

### General rights

Copyright and moral rights for the publications made accessible in the public portal are retained by the authors and/or other copyright owners and it is a condition of accessing publications that users recognise and abide by the legal requirements associated with these rights.

- Users may download and print one copy of any publication from the public portal for the purpose of private study or research.
- You may not further distribute the material or use it for any profit-making activity or commercial gain
- You may freely distribute the URL identifying the publication in the public portal

If you believe that this document breaches copyright please contact us providing details, and we will remove access to the work immediately and investigate your claim.

# CHAOTIC DUFFING TYPE OSCILLATOR WITH INERTIAL DAMPING

Arūnas Tamaševičius<sup>1</sup>, Gytis Mykolaitis<sup>1,2</sup>, Raimundas Kirvaitis<sup>3</sup>,  
Elena Tamaševičiūtė<sup>1,4</sup>, Škaidra Bumelienė<sup>1</sup>, and Erik Lindberg<sup>5</sup>

<sup>1</sup>Plasma Phenomena and Chaos Laboratory,  
Semiconductor Physics Institute, A. Goštauto 11, Vilnius, LT-01108, Lithuania  
e-mail: tamasev@pfi.lt; gytis@pfi.lt; skaidra@pfi.lt  
WWW: [http://www.pfi.lt/index\\_e/](http://www.pfi.lt/index_e/)

<sup>2</sup>Department of Physics, Faculty of Fundamental Sciences,  
Vilnius Gediminas Technical University, Saulėtekio 11, Vilnius, LT-10223, Lithuania  
e-mail: gytis@pfi.lt

WWW: <http://www.fm.vgtu.lt/en/>  
<sup>3</sup>Department of Electronic Systems, Faculty of Electronics,  
Vilnius Gediminas Technical University, Naugarduko 41, Vilnius, LT-03227, Lithuania  
e-mail: raimundas.kirvaitis@adm.vgtu.lt

WWW: <http://www.el.vgtu.lt/en/>  
<sup>4</sup>Department of General Physics and Spectroscopy, Faculty of Physics,  
Vilnius University, Saulėtekio 9, Vilnius, LT-10222, Lithuania  
e-mail: elena.tamaseviciute@ff.vu.lt  
WWW: <http://www.vu.lt/en/>

<sup>5</sup>DTU Elektro Department, Electronics & Signalprocessing, 348  
Technical University of Denmark, Lyngby, DK-2800, Denmark  
e-mail: el@elektro.dtu.dk  
WWW: <http://www.elektro.dtu.dk/English.aspx>

**Abstract**—A novel Duffing–Holmes type autonomous chaotic oscillator is described. In comparison with the well-known non-autonomous Duffing–Holmes circuit it lacks the external periodic drive, but includes two extra linear feedback subcircuits, namely a direct positive feedback loop, and an inertial negative feedback loop. SPICE simulation and hardware experimental results are presented.

## I. INTRODUCTION

The Duffing–Holmes non-autonomous oscillator is a classical example of a nonlinear dynamical system exhibiting complex also chaotic behaviour [1–3]. It is given by the second-order differential equation with an external periodic drive term:

$$\ddot{x} + b\dot{x} - x + x^3 = a \sin \omega_1 t. \quad (1)$$

Three different techniques are used to solve the Duffing–Holmes equation and/or to process its solutions electronically. *The first* approach is a hybrid one making use of integration the equation in

a digital processor and of the digital-to-analogue conversion of the digital output for its further analogue processing, analysis and display [4, 5]. *The second* method employs purely analogue hardware based on analogue computer design [6–9]. For example, analogue computer has been used to simulate Eq. (1) and to demonstrate the effect of scrambling chaotic signals in linear feedback shift registers [6–8]. Later analogue computer has been suggested for demonstration of chaos from Eq. (1) for the undergraduate students [9]. *The third* technique is based on building some specific analogue electrical circuit imitating dynamical behaviour of Eq. (1). The Young–Silva oscillator [10] described in more details in [11] and used to demonstrate the effect of resonant perturbations for inducing chaos [12, 13] is an example. Recently the Young–Silva circuit has been essentially modified and used to test the control methods for unstable periodic orbits [14, 15] and unstable steady states [16] of dynamical systems. The modified version has been characterized in details both numerically and experimentally in [17].

Evidently the first and the second techniques are rather general and can be applied to other differential equations as well. In contrast, the third approach is limited to a specific equation. Despite this restriction the “intrinsic” electrical circuits have an attractive advantage due to their extreme simplicity and cheapness.

One may think of such analogue electrical circuits as of analogue computers. This is true from a mathematical and physical point of view in the sense that the underlying equations are either exactly the same or very similar also that the dynamical variables in the both cases are represented by real electrical voltages and/or currents. However, the circuit architecture of an analogue computer, compared to an “intrinsic” nonlinear circuit, is rather different. Any analogue computer is a standard collection of the following main processing blocks: inverting RC integrators, inverting adders, inverting and non-inverting amplifiers, multipliers, and piecewise linear nonlinear units. Meanwhile the specific analogue circuits comprise only small number of electrical components: resistors, capacitors, inductors, and semiconductor diodes. In addition, they may include a single operational amplifier (in some cases several amplifiers). The differences between the “intrinsic” analogue electrical circuits, simulating behaviour of the specific dynamical systems, and the common analogue computers are discussed in [18].

In this paper, we introduce, as an alternative for the non-autonomous Eq. (1), an autonomous version of the Duffing type oscillator given by

$$\begin{aligned} \ddot{x} - b\dot{x} - x + x^3 + kz &= 0, \\ \dot{z} &= \omega_f(\dot{x} - z) \end{aligned} \quad (2)$$

or equivalently by a set of three first order differential equations

$$\begin{aligned} \dot{x} &= y, \\ \dot{y} &= x - x^3 + by - kz, \\ \dot{z} &= \omega_f(y - z). \end{aligned} \quad (3)$$

Here  $z$  is the third independent dynamical variable,  $\omega_f$  is its characteristic rate, and  $k$  is the feedback coefficient. We emphasize in Eq. (2) an opposite sign of the damping term, compared to Eq. (1). The negative damping,  $-b\dot{x}$  in Eq. (2), or  $+by$  in Eq. (3) yields an additional spiral instability. Also we propose a specific electrical circuit imitating solutions of Eq. (3).

## II. CIRCUITRY

First of all we recall to the *non-autonomous* circuit shown in Fig.1 for comparison. The novel *autonomous* circuit is presented in Fig. 2.

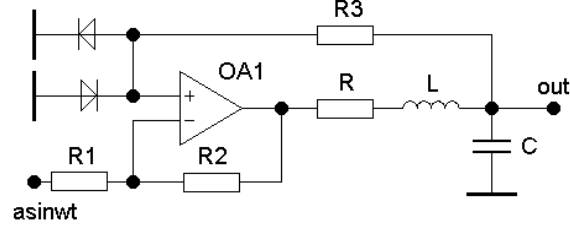

Fig. 1. Circuit implementation of the *non-autonomous* Duffing-Holmes oscillator [17].

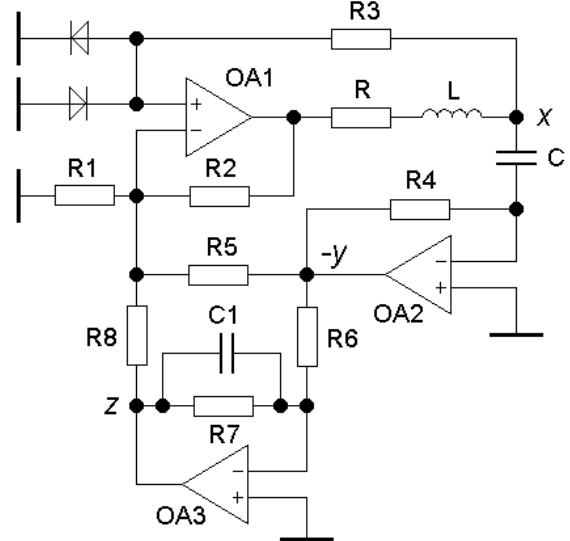

Fig. 2. Circuit implementation of the *autonomous* Duffing-Holmes type oscillator. Any of the nodes lettered as ‘x’, ‘-y’ or ‘z’ can be taken for the output.

The non-autonomous oscillator contains a single *nonlinear* positive feedback loop introduced by the resistor R3, two diodes, and the operational amplifier OA1. The external periodic drive is given by  $asin\omega t$ .

The autonomous oscillator lacks the external periodic drive, but includes two additional linear feedback loops. The circuit composed of the OA2 based stage and the resistor R5 introduce the positive feedback loop, specifically negative damping in Eq. (2). While the circuit including the OA2–OA3 stages (note a capacitor C1 in the latter stage) and the resistor R8 compose the inertial negative feedback, specifically the inertial damping term  $kz$  in Eq. (2).

### III. SIMULATION RESULTS

The oscillator in Fig. 2 has been simulated using the *ELECTRONICS WORKBENCH* package (*SPICE* based software) and the results are shown in Figs. 3–5.

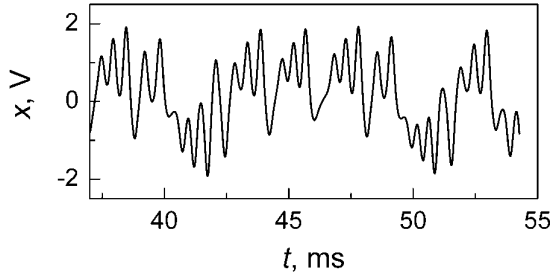

Fig. 3. Snapshot of typical chaotic waveform of  $x(t)$  from the autonomous Duffing type oscillator.  $L = 19$  mH,  $C = 470$  nF,  $C1 = 20$  nF,  $R = 20$   $\Omega$ ,  $R1 = 30$  k $\Omega$ ,  $R2 = 10$  k $\Omega$ ,  $R3 = 30$  k $\Omega$ ,  $R4 = 820$   $\Omega$ ,  $R5 = 75$  k $\Omega$ ,  $R6 = R7 = 10$  k $\Omega$ ,  $R8 = 20$  k $\Omega$ . The OA1 to OA3 are the LM741 type or similar operational amplifiers, the diodes are the 1N4148 type or similar general-purpose devices.

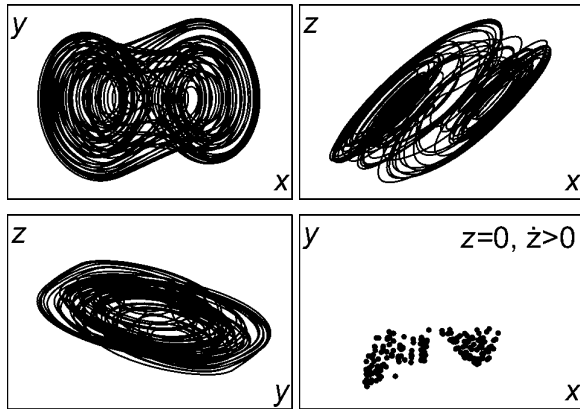

Fig. 4. Simulated phase portraits and Poincaré section (bottom right). Element values are the same as in Fig. 3.

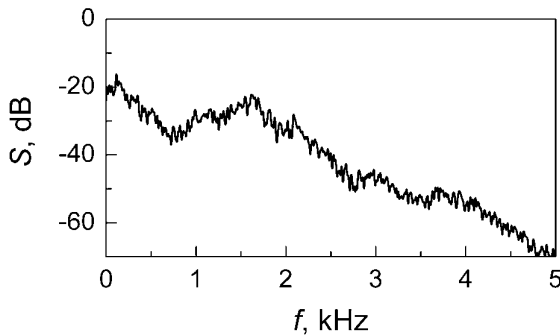

Fig. 5. Simulated power spectrum  $S$  from the variable  $x(t)$ . Circuit element values are the same as in Fig. 3.

### IV. HARDWARE EXPERIMENTS

The autonomous oscillator has been built using the elements described in the caption to Fig. 3. Typical experimental results are presented in Figs. 6–8.

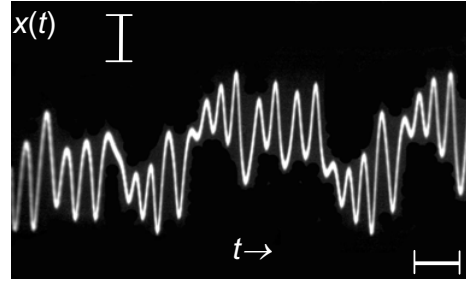

Fig. 6. Experimental snapshot of chaotic waveform  $x(t)$ . Horizontal scale 2 ms/div. Vertical scale 1 V/div. Element values are the same as in Fig. 3, except  $R5 = 68$  k $\Omega$ .

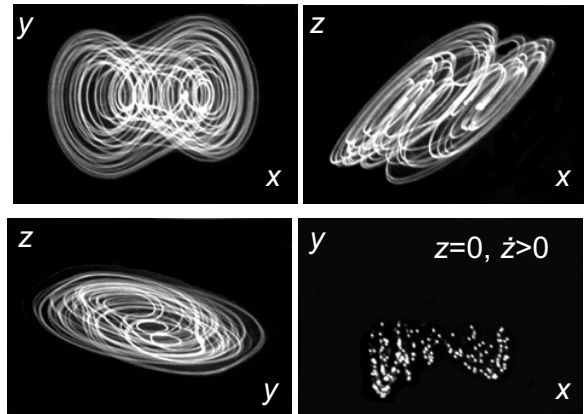

Fig. 7. Experimental phase portraits and Poincaré section (bottom right). Circuit element values are the same as in Fig. 3, except  $R5 = 68$  k $\Omega$ .

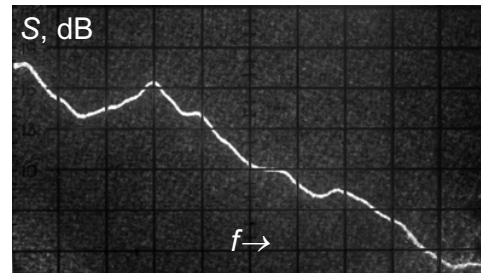

Fig. 8. Experimental power spectrum  $S$  from the output signal  $x(t)$ . Frequency range 0 to 5 kHz. Horizontal scale 500 Hz/div., resolution 100 Hz. Vertical scale 10 dB/div. Circuit element values are the same as in Fig. 3, except  $R5 = 68$  k $\Omega$ .

## V. CONCLUDING REMARKS

We have designed and built a novel Duffing–Holmes type autonomous third–order chaotic oscillator. In comparison with the common non–autonomous Duffing–Holmes type oscillator the autonomous circuit has an internal positive feedback loop instead of an external periodic drive source. In addition, it is supplemented with an RC inertial damping loop providing negative feedback. The circuit has been investigated both numerically and experimentally. The main characteristics, including the time series, phase portraits, Poincaré sections, and power spectra have been calculated using the SPICE based software, also taken experimentally. Fairly good agreement between the simulation and the hardware experimental results is observed (Figs. 3–8). Some discrepancy (about 10%) between the model and the hardware prototype, namely  $R_5 = 75 \text{ k}\Omega$  in the model (Figs. 3–5) and  $R_5 = 68 \text{ k}\Omega$  in the experimental circuit (Figs. 6–8) can be explained in the following way. The inductive element in the model is an ideal device in the sense that  $L = \text{const}$ . Meanwhile the inductance of a real inductor, e.g. a coil wound on a ferrite core has a slight dependence on the current  $L = L(I)$ .

Finally, we emphasize that the described autonomous oscillator is not simply a formal alternative to the classical non–autonomous Duffing–Holmes oscillator. An externally driven chaotic oscillator has a sharp and  $\approx 20 \text{ dB}$  high peak in the power spectrum at the drive frequency  $f_1 = \omega_1/2\pi$ . While autonomous oscillator exhibits no peaks but essentially smoother spectra (Figs. 5, 8). This feature may have an advantage in practical applications.

## REFERENCES

1. E. Ott. *Chaos in Dynamical Systems*. Cambridge: Cambridge University Press, 1993.
2. R.C. Hilborn. *Chaos and Nonlinear Dynamics: An Introduction for Scientists and Engineers*. Oxford: Oxford University Press, 2006.
3. P. Cvitanović *et al.* *Chaos: Classical and Quantum*, stable version 12. Copenhagen: Niels Bohr Institute, 2008. <<http://ChaosBook.org>>.
4. A. Namajūnas and A. Tamaševičius. An optoelectronic technique for estimating fractal dimensions from dynamical Poincaré maps. In *IFIP Trans.*, v. A41. Amsterdam: Elsevier Science, 1994. pp. 289–293.
5. A. Namajūnas and A. Tamaševičius. Simple laboratory instrumentation for measuring pointwise dimensions from chaotic time series. *Rev. Sci. Instr.*, v. 65, pp. 3032–3033, 1994.
6. A. Namajūnas, A. Tamaševičius, A. Čenys, and A.N. Anagnostopoulos. Whiteness power spectra of chaotic signals. In: *Proc. NDES'99*, Rønne, Denmark, 1999, pp. 137–140.
7. A. Namajūnas, A. Tamaševičius, G. Mykolaitis, and A. Čenys. Spectra transformation of chaotic signals. *Lith. J. Phys.*, v. 40, pp. 134–139, 2000.
8. A. Namajūnas, A. Tamaševičius, G. Mykolaitis, and A. Čenys. Smoothing chaotic spectrum of nonautonomous oscillator. *Nonlinear Phenomena in Complex Systems*, v. 3, no. 2, pp. 188–191, 2000.
9. B.K. Jones and G. Trefan. The Duffing oscillator: a precise electronic analog chaos demonstrator for the undergraduate laboratory. *Am. J. Phys.*, v. 69, pp. 464–469, 2001.
10. C.P. Silva and A.M. Young. High frequency anharmonic oscillator for the generation of broadband deterministic noise. U.S. Patent No. 6,127,899. October 3, 2000.
11. A.K. Kandangath. *Inducing chaos in electronic circuits by resonant perturbations*: Master Thesis. Tempe: Arizona State University, 2004. <<http://www.ecogito.net/projects/>>.
12. Y. –C. Lai, A. Kandangath, S. Krishnamoorthy, J.A. Gaudet, and A.P.S. de Moura. Inducing chaos by resonant perturbations: theory and experiment. *Phys. Rev. Lett.*, v. 94, no. 21, 214101, 2005.
13. A. Kandangath, S. Krishnamoorthy, Y. –C. Lai, and J.A. Gaudet. Inducing chaos in electronic circuits by resonant perturbations. *IEEE Trans. Circuits and Systems–I*: v. 54, pp. 1109–1119, 2007.
14. A. Tamaševičius, E. Tamaševičiūtė, G. Mykolaitis, and S. Bumelienė. Stabilisation of unstable periodic orbit in chaotic Duffing–Holmes oscillator by second order resonant negative feedback. *Lith. J. Phys.*, v. 47, pp. 235–239, 2007.
15. A. Tamaševičius, G. Mykolaitis, V. Pyragas, and K. Pyragas. Delayed feedback control of periodic orbits without torsion in nonautonomous chaotic systems: theory and experiment. *Phys. Rev. E*, v. 76, no. 2, 026203, 2007.
16. A. Tamaševičius, E. Tamaševičiūtė, G. Mykolaitis, and S. Bumelienė. Switching from stable to unknown unstable steady states of dynamical systems. *Phys. Rev. E*, v. 78, no. 2, 026205, 2008.
17. E. Tamaševičiūtė, A. Tamaševičius, G. Mykolaitis, S. Bumelienė, and E. Lindberg. Analogue electrical circuit for simulation of the Duffing–Holmes equation. *Nonlinear Analysis. Modelling and Control*, v. 13, pp. 241–252, 2008. <<http://www.lana.lt/journal/issues.php>>.
18. T. Matsumoto, L.O. Chua, and M. Komuro. The double scroll. *IEEE Trans. Circuits and Systems*, v. 32, pp. 797–818, 1985.