

Technical University of Denmark



Control strategies for operation of pitch regulated turbines above cut-out wind speeds

Markou, Helen; Larsen, Torben J.

Published in:
EWEC 2009 Proceedings online

Publication date:
2009

Document Version
Publisher's PDF, also known as Version of record

[Link back to DTU Orbit](#)

Citation (APA):
Markou, H., & Larsen, T. J. (2009). Control strategies for operation of pitch regulated turbines above cut-out wind speeds. In EWEC 2009 Proceedings online EWEC.

DTU Library

Technical Information Center of Denmark

General rights

Copyright and moral rights for the publications made accessible in the public portal are retained by the authors and/or other copyright owners and it is a condition of accessing publications that users recognise and abide by the legal requirements associated with these rights.

- Users may download and print one copy of any publication from the public portal for the purpose of private study or research.
- You may not further distribute the material or use it for any profit-making activity or commercial gain
- You may freely distribute the URL identifying the publication in the public portal

If you believe that this document breaches copyright please contact us providing details, and we will remove access to the work immediately and investigate your claim.

Control Strategies for operation of pitch regulated turbines above cut-out wind speeds

Helen Markou¹ and Torben J. Larsen, Risø-DTU, P.O.box 49, DK-4000 Roskilde, Denmark

Abstract

The importance of continuing production in high winds to ensure a reliable and robust energy production is increasing from the grid companies perspective. Control strategies that will enable a pitch regulated variable speed 2MW turbine to produce power at wind speeds beyond the normal cut-out wind speed of 25m/s without substantially increasing the loads are investigated. A set of load cases for wind speeds from 4m/s to 50m/s for a IEC61400-1 rev 3 class IA turbine has been performed. Statistics in terms of mean value and standard deviation are analysed and rainflow calculations are performed to estimate the impact over the lifetime of the turbine. Initially, an alternative power-speed control to the traditional approach is investigated, in which the rotor speed and power set-points are gradually reduced, for increasing wind speeds above the cut-out wind speed of 25m/s. With the above suggested control strategy, it is possible to limit the rotor loads but the tower vibration loads, both fore-aft and side-to-side, are still increasing. As a result, additional load reduction controllers are investigated. First, a fore-aft tower damper algorithm using collective pitch based on measurements of the fore-aft tower top acceleration signal and second, a side-to-side tower damper algorithm using an additional torque demand, based on measurements of the side-to-side tower top acceleration, makes significant load reductions of the fore-aft and side-to-side tower loading possible. The load reduction controllers manage to substantially decrease this loading, if not to the original loads with shutdown at 25m/s.

Introduction

Wind turbines normally operate between a cut-in wind speed of 3-4m/s and a cut-out wind speed of 25m/s. This operational range is defined based on lifetime cost optimization criteria for the turbine: the overall power production during operation at above cut-out wind speeds is limited, and does not compensate for the higher loads experienced by the turbine at these wind speeds; i.e. the turbine is not designed to withstand these higher loads. In cases of a storm passing through, the wind-farm will shut-down, usually from operating at rated power output. Due to high penetration of wind energy into the electricity grid, there is a keen interest from the grid companies to ensure a reliable and robust energy production in storm situations, even if the turbine is not running at rated power output. To the best of our knowledge work on incurring loads from storm reduction control strategies have not been published. Enercon have implemented a storm control strategy on their turbines, in which the rotational speed is reduced above a V_{storm} : the cut-out wind speed is between 28m/s and 34m/s.

¹ Correspondence to: H. Markou, Risø-DTU, P.O.Box 49, DK-4000 Roskilde, Denmark.
Email:helen.markou@risoe.dk. PSO-project:

Objective

Control strategies that enable power production of a pitch regulated variable speed 2MW turbine in storm conditions with wind speeds up to 50m/s, and keep the loads within a reasonable level, compared to the loads experienced with normal operation up to 25m/s, are investigated.

Method

A set of load cases for wind speeds from 4m/s to 50m/s with turbulence intensities according to IEC61400-1 rev 3 class IA [1] has been performed in the Risø-DTU non-linear wind turbine simulation tool HAWC2 [2]. A class IA turbine i.e. high turbulence site and high average wind speed, has been selected as the worst case scenario for this investigation. Statistics in terms of mean value and standard deviation of these simulations are analysed: In order to keep the loads within a reasonable range the mean values and standard deviation must be similar or lower than seen at the normal cut-out wind speed of 25m/s.

Rainflow calculations are performed to assess the impact over the lifetime of the turbine, with the relative contribution to fatigue damage by wind speed analysed. The loads experienced by the turbine in wind speeds up to 25m/s and up to 50m/s are compared, firstly without changing the power-speed controller strategy used ('basic controller'), and secondly with an alternative power-speed controller in which the power and rotational speed set-points are reduced at high wind speeds ('storm controller'). Based on these results, additional control strategies that could potentially result in a reduction of the loads are implemented and the results compared to the loads when running up to 25m/s and to those experienced with only the 'storm control' strategy. The following two additional controller concepts are investigated: a fore-aft tower damper algorithm using collective pitch based on measurements of the fore-aft tower top acceleration signal; a side-to-side tower damper algorithm using an additional torque demand, based on measurements of the side-to-side tower top acceleration.

Control Strategies

The following controllers are used in this investigation:

- **Nominal case** used as the base case in the load comparisons: power-speed regulation up to 25m/s and idling in the higher winds.
- The same power-speed controller that is used to operate the turbine up to 25m/s is used to operate the turbine up to 50m/s (**Basic_50**). In above rated the rated torque and speed set points are not altered.
- The Storm Controller (**St1**) sees a reduction of power and rotational speed set-points at high wind speeds as described in the following section.
- Fore-aft tower damper (**ATD**)
- Side-to-side tower damper (**LTD**)

Power-Speed Regulation

The basic power-speed control strategy for the 2MW turbine illustrated in Figure 1 is pitch control in combination with constant generator torque in above rated wind speed, and variable speed operation in below rated wind speed in combination with constant speed just below rated power. The pitch angle and generator torque is determined by two PI controllers on the low pass filtered rotational speed of the rotor. The transition between the three different operating regions variable speed, constant speed, constant power is enabled by adjusting the max-min ranges of the PI controllers by logical switches and low pass filters to enable a smooth transition. The tuning of the PI-control parameters are performed according to the methods described in [3]. Responses of this implementation to step changes in wind speed are presented in [4].

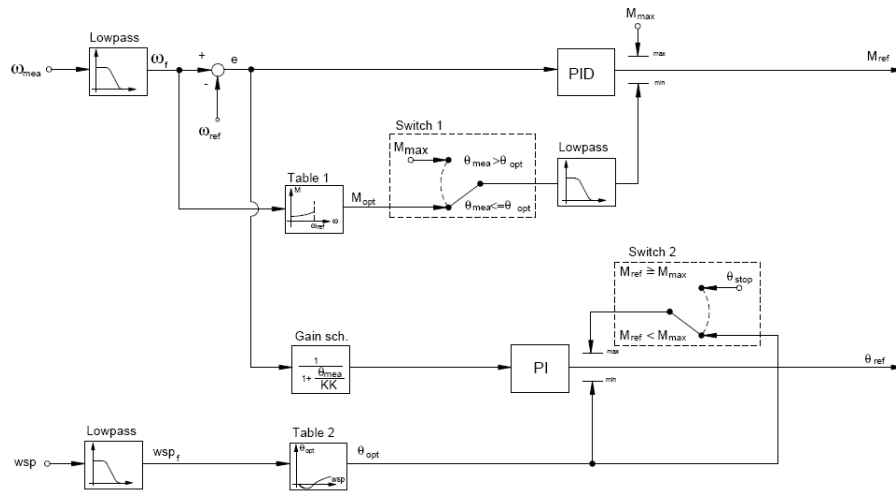

Figure 1: Control diagram of the basic power-speed controller

An alternative storm-control strategy for power-speed control in above rated wind speeds is to gradually reduce the rotor speed and power set-points, thus maintaining the nominal shaft torque, for increasing wind speeds above the cut-out wind speed of 25m/s. The power and rotor speed set-points are reduced from their nominal values at 25/s to about half the nominal values at 50m/s. The average pitch angle for the storm controller strategy is very high, with the turbine operating up to 60-70 degrees above 45m/s. A comparison of the steady state values for the two controllers in terms of rotational speed, pitch angle and electrical power can be seen in Figure 2.

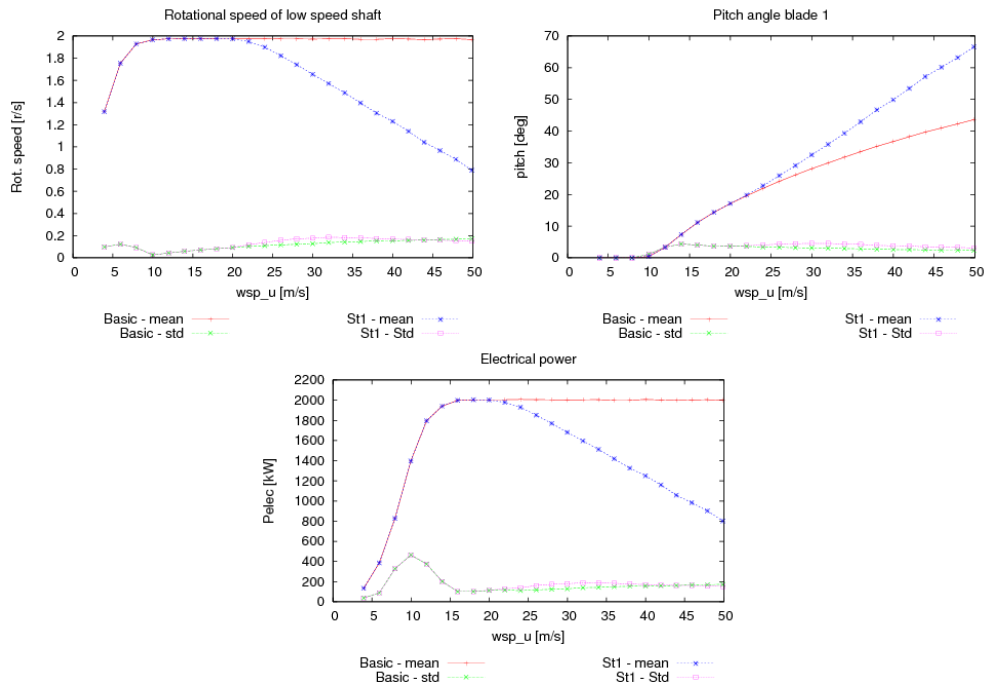

Figure 2: Operational strategy of storm control strategy (st1) compared to the nominal power-speed control strategy (Basic): mean value and standard deviation.

Load reduction controllers

Two active tower dampers are implemented, one for increasing the fore-aft tower damping Figure 3(a) and one for increasing the side-to-side tower damping Figure 3(b). The fore-aft tower damper output signal is an additional collective pitch angle $\Delta\theta$ to the power speed collective pitch (Pitch Ref); a band-pass filtered measurement of the fore-aft tower top acceleration signal tow_acc_y , multiplied by a proportional gain is the input. In a very similar manner, in order to increase the lateral tower damping, the band-pass filtered sideward tower top acceleration tow_acc_x , multiplied by a proportional gain, is added as an additional torque reference signal DT to the existing torque reference signal from the existing power-speed regulator (Torque Ref). The design and tuning of the controllers is presented in detail in [4].

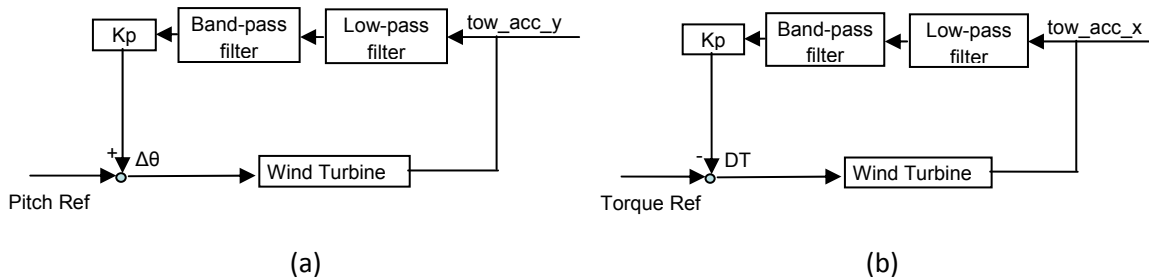

Figure 3: Control strategy for the fore-aft tower damper (ATD) and for the side-to-side tower damper (LTD).

Statistical overview

Statistics in terms of mean value and standard deviation of the simulated time-series are analysed: In order to ensure the loads are within a reasonable range the mean values and standard deviation should be similar or lower than seen at the normal cut-out wind speed of 25m/s. When looking at the results it should be however also taken into account that the contribution to fatigue damage is highly dependant on the number of hours of operation at that wind speed. The latter are highly reduced at very high winds: at 40m/s, for example, there is 1.5h of operation in the 20 year lifetime for a class 1A turbine.

Power-Speed regulation

A comparison of the blade and shaft loads for the nominal and the storm-control strategy can be seen in Figure 4 and of the tower loads in Figure 5. The 'basic' power-speed controller results in increasing loads on all major load components in the higher wind speeds. With the storm-control strategy, it is seen that it is possible to limit the rotor loads and the shaft loads to the normal operation loads at 25m/s. The tower vibration loads, both fore-aft and side-to-side, are still increasing though. The reason for this increase in tower loads, in combination with high load input from the high wind speeds, is the reduced aerodynamic damping as a direct consequence of the very high pitch angles: the turbine operates at pitch angles up to 60-70 degrees at 50m/s in order to limit the aerodynamic forces.

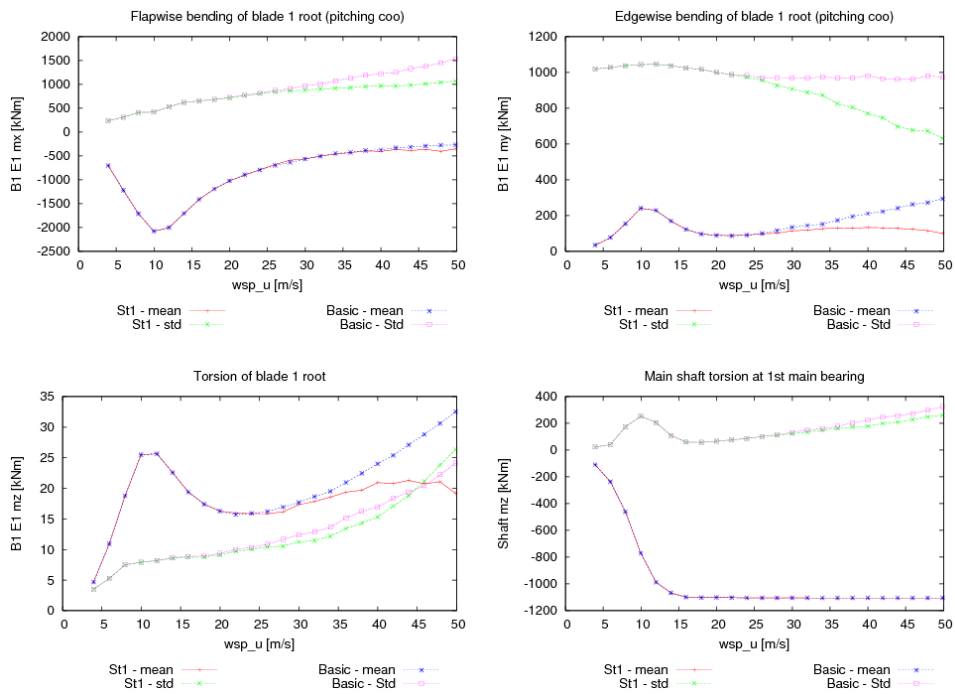

Figure 4: Comparison of mean values and standard deviation of the blade root moments (flapwise, edgewise) and shaft moments for the storm control strategy (st1) and the nominal power-speed control strategy (Basic).

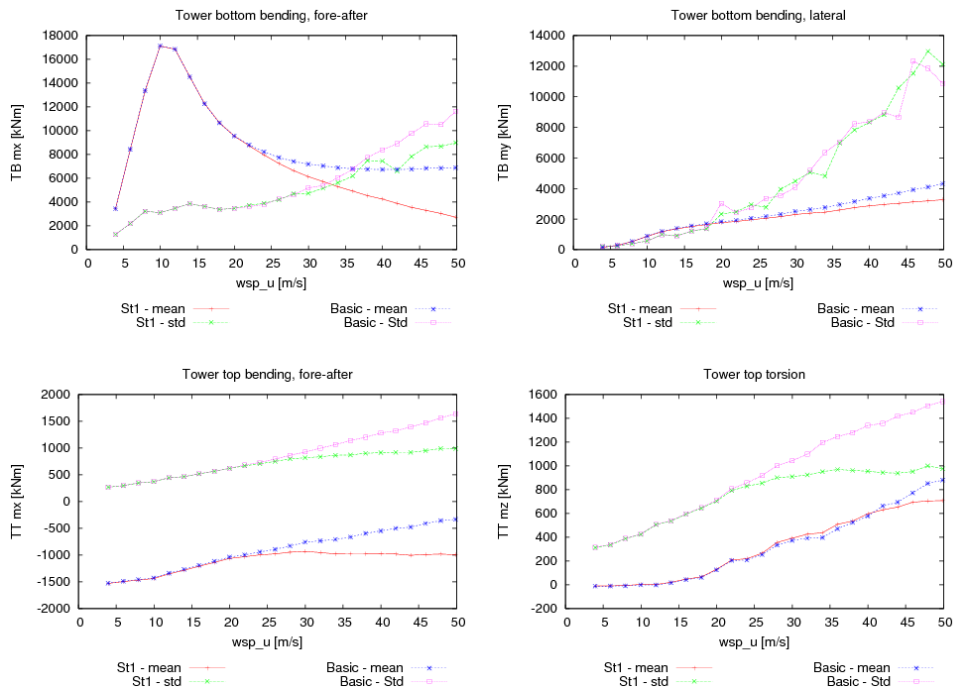

Figure 5: Comparison of mean values and standard deviation of the tower bottom and tower top moments (fore-aft, lateral) for the storm control strategy (st1) and the nominal power-speed control strategy (Basic).

Load reduction controllers

A comparison of the mean, max, min and standard deviation of the tower bottom fore-aft bending moment and the pitch angle (actuator) of the simulated time-series of the storm control strategy with and without the fore-aft tower damper active is seen in Figure 6. The fore-aft tower damper reduces the standard deviations of the tower bottom fore-aft bending moment in wind speeds from 20m/s and above. The highest reduction is above 35m/s, the fatigue reduction in these wind speeds will not be high as the hours of operation are limited. The duty on the pitch system with the additional collective pitch angle contribution from the fore-aft tower damper is negligible.

A comparison of the mean, max, min and standard deviation of the tower bottom lateral bending moment and the shaft torque mean value (actuator) of the simulated time-series of the storm control strategy with and without the additional lateral tower damper is presented in Figure 7. The lateral tower damper results in a reduction of the standard deviation of the side-to-side tower moment at almost all wind speeds, with no changes in its mean value. The penalty is a small increase in the shaft moment's standard deviation at the higher wind speeds above 40m/s.

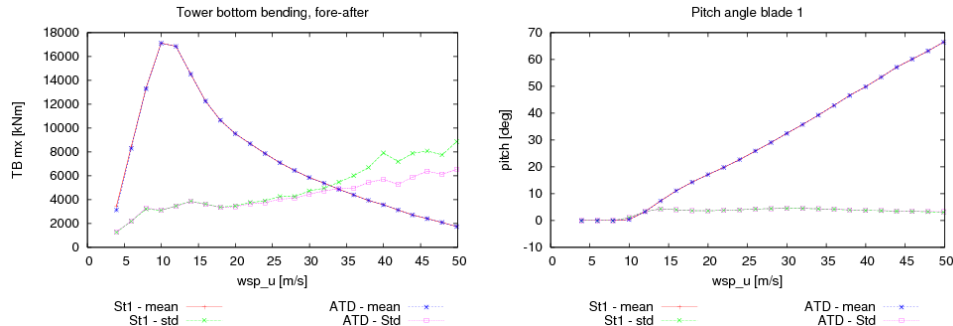

Figure 6: Comparison of mean values and standard deviation of the tower bottom side-to-side moment and the actuator response (pitch angle) for the storm control strategy (st1) and the fore-aft tower damper (ATD).

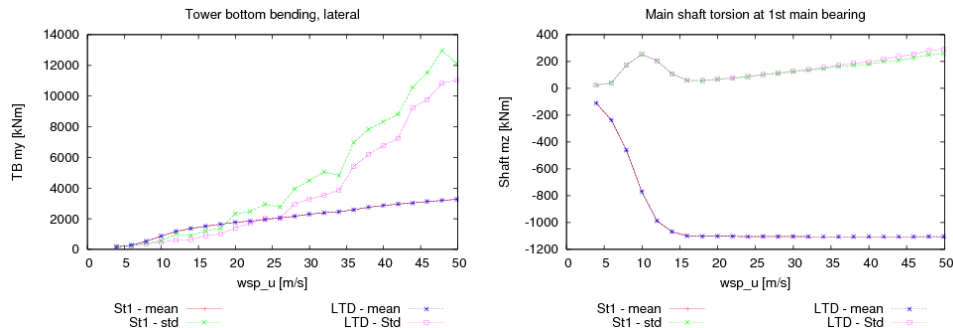

Figure 7: Comparison of mean values and standard deviation of the tower bottom lateral moment and actuator response (shaft moment) for the storm control strategy (st1) and lateral tower damper (LTD).

Fatigue measures

To quantify the increase in fatigue loads, a fatigue analysis is performed for all the controllers and the 1Hz equivalent loads compared to the nominal case, i.e. operating up to 25m/s and idling in the higher winds. It should be noted that a 'worst-case' scenario has been chosen in terms of selected site type (Class IA). The Weibull distribution will bias to the lower wind speed ranges in Class II and Class III turbines ($V_{ave}=10, 8.5, 7.5$ respectively for the three wind classes).

The following design load situations as defined in the IEC61400-1 rev 3 standard for fatigue analysis are considered:

- Power production from cut-in to cut-out wind speeds (DLC 1.2)
- Parked (standing still or idling) up to $0.7 \cdot V_{ref}$: modified to idle up to 50m/s (DLC 6.1)
- Start-up and shut-down (DLC 3.1 and DLC 4.1)

In order to assess the impact of start-ups and shut-downs when operating in the higher winds, these are included in the fatigue analysis for three cases: the 'nominal' case i.e. operating up to 25m/s and operating up to 50m/s with and without the storm controller active. Start-up and shut-down is not included in the case of the load reduction controllers as in these design cases no wind turbulence is included in the windfield and the effect of start-up and shut-down will be as for the power-speed controllers. A number of 1000 occurrences of both start-up and shut-down are included. Each simulation is 200 seconds resulting in 57h of each start-up and shut-down over the turbine lifetime. Results are presented with and without start-up and shut-down included.

Power Speed regulation

A rainflow count is performed, for both the basic and storm controller running up to 50m/s, referred to as 'Basic_50' and 'Basic_st1' respectively. In Table 1 The 1Hz equivalent loads are compared to the nominal case i.e. operating up to 25m/s with the basic controller and then idling up to 50m/s. The main results shown do not include start-up and shut-down. With start-up and shut-down the blade flap moment ratio changes (the ratio in bold/brackets).

- The contribution from operation in the higher winds is not very high for the blade and tower top loads, especially with the storm controller active (basic_st1). In this case the increase in flap loads is only 2%, and 4% and 2% for the yaw and tilt loads respectively.
- The tower fore-aft loads are increased by 5% and the side-to-side loads are actually decreased by 18% as the generator operation in higher winds seems to act as a damper to the tower side-to-side loads.
- The fact that the fatigue loads are not substantially increased is due to turbine not operating at these higher wind speeds for a substantial amount of time, even though the worst case scenario from the IEC61400-1 rev 3 has been selected for this study, i.e. a Class I wind turbine. In fact not even 1h in total in a lifetime of 20y is spent above 40m/s.
- Start-up and shut-down flap loads are higher when idling in the higher winds than if operating.

Equiv. load ranges for N=10E7		
Load sensor (1Hz eq. load)	Basic_50	Basic_st1
Blade flap moment, m=12	1.07 / [1.04]	1.02 / [1.00]
Blade edge moment, m=12	1.00	1.00
Tower top tilt moment, m=6	1.05	1.02
Tower top yaw moment, m=6	1.06	1.04
Tower bottom fore-aft moment, m=6	1.05	1.05
Tower bottom lateral moment, m=6	0.84	0.82
Shaft bending moment	1.01	1.01

Table 1: Equivalent loads of the basic and storm controller when running up to 50m/s, as compared to those when running up to 25m/s. The ratio in the brackets are with start-up and shut-down included.

Load reduction controllers

The 1Hz equivalent loads are calculated and compared to the nominal case: operation up to 25m/s and idling up to 50m/s. For completeness the results for the fore-aft tower damper (ATD) and the side-to-side tower damper are shown in Table 2 with the basic controller 50m/s (Basic_50) and the storm controller (St1).

- The fore-aft tower damper reduces the blade flap loads to 94% of the nominal case and the tower bottom fore-aft loads from 5% (Basic_50) above to 2% above the nominal case.
- The lateral tower damper reduces even further the lateral tower loads to 61% of the nominal case, with no increase in the shaft loading.

The three load reduction control strategies presented do not compete with each other: the LTD uses a different actuator and the ATD does not change the pitch average value. It is expected that the load reductions achieved by implementing these independantly in HAWC2 would be the same if running these controllers at the same time. The only loads that have not been reduced to the value of or below that of the nominal case are the tower top loads and the tower bottom fore-aft. Compared to the nominal case they are 2% higher.

Extreme Loads

An indication of the ultimate loads on the turbine is given from the maximum values of the load cases performed for the fatigue analysis. The ratio of the maximum values for all the implemented controllers divided by the maximum values from the nominal case is presented in Table 3. For a complete analysis of the extreme loads on the turbine an ultimate strength analysis according to [1] would need to be performed and additional design load cases of power production with the occurrence of a fault could contribute to the the ultimate loading of the turbine (DLC 2.2 and DLC 2.3).

In contrast to the fatigue loads the ultimate loads are higher when running up to 50m/s (Table 3), specifically for the tower-top and the shaft moments. Taking all load reduction controllers into account:

- For the blade moments the maximum load increases by 5%-7%.
- For the tower bottom fore-aft there is a 4% increase and for the tower bottom side-to-side a 25% decrease.
- The tower top moments, both tilt and yaw, see an increase of 35%.
- The shaft maximum load increases by 55%.

Equiv. load ranges for N=10E7				
Load sensor (1Hz eq. load)	Basic_50	St1	ATD	LTD
Blade flap moment, m=12	1.07	1.02	0.94	1.01
Blade edge moment, m=12	1.00	1.00	1.00	1.00
Tower top tilt moment, m=6	1.05	1.02	1.02	1.01
Tower top yaw moment, m=6	1.06	1.04	1.03	1.02
Tower bottom fore-aft moment, m=6	1.05	1.05	1.02	1.04
Tower bottom lateral moment, m=6	0.84	0.82	0.83	0.61
Shaft bending moment	1.01	1.01	1.01	1.00

Table 2: Equivalent loads of the load reduction controllers when running up to 50m/s, as compared to those when running up to 25m/s + idling.

Load sensor	Basic_50	St1	ATD	LTD
Blade flap moment	1.58	1.29	1.07	1.29
Blade edge moment	1.62	1.08	1.05	1.08
Tower top tilt moment,	1.92	1.46	1.35	1.47
Tower top yaw moment	2.28	1.58	1.35	1.56
Tower bottom tilt moment	1.86	1.20	1.04	1.17
Tower bottom side moment	0.83	0.82	0.95	0.76
Shaft bending moment	1.63	1.55	1.54	1.58

Table 3: Ratio of maximum values from implemented controllers divided by the maximum values of the nominal case i.e. basic controller running to 25m/s and idling thereafter.

Conclusions

A set of load cases ranging from wind speeds at 4m/s to 50m/s with turbulence intensities according to IEC61400-1 rev 3 class IA has been performed in order to calculate the increase in fatigue damage when allowing the turbine to run in storm conditions. Two power speed controllers were implemented: the 'nominal' controller running up to 50m/s and a storm control strategy (St1). Statistical analysis shows that even with the storm controller active focus needs to be put on the tower loads of the turbine. Load reduction controllers that have been implemented is a fore-aft tower damper (ATD) and a lateral tower damper (LTD).

From the fatigue analysis it was concluded that operation in storm situations does not increase the fatigue loads, and is actually favourable for the tower side-to-side loads. More specifically:

- When running up to 50m/s with no load reduction controllers implemented the increase in fatigue loads is not prohibitively high:
 - The blade flap loads are increased by 7%, the tower top loads by 5-6%.
 - The effect of operating is actually favourable for the tower side-to-side loads, compared to idling, due to damping provided by the generator torque.
- The storm control strategy reduces the blade flap loads and the tower top loads, and has a negligible effect on the tower loads. The reason for this increase in tower loads is a combination of high load input from the high wind speeds and reduced aerodynamic damping as a direct consequence of the very high pitch angles: the turbine operates at pitch angles up to 60-70 degrees at 50m/s in order to limit the aerodynamic forces.
- The fore-aft tower damper reduces the fore-aft tower bottom loads from 5% higher compared to the nominal case to 2% higher than the nominal case.
- The side-to-side tower damper reduces the side-to-side loads from 84% compared to the nominal to 61% compared to the nominal.

A complete ultimate load analysis was not performed, according to the IEC standard. An indication from the maximum values during operation, with and without load reduction controllers, shows that these are increasing, especially for the tower top moments, which see an increase of about 35%, and the shaft moment, which sees an increase of around 55%.

Acknowledgements

The Danish Energy Agency is acknowledged for funding this work in contract number PSO-F&U 2006-1-6319. The work is carried out by the Wind Energy Department at Risø-DTU National Laboratory in cooperation with Aalborg University.

References

1. IEC 61400-1, Wind Turbines – Part 1: Design requirements, third edition, 2005-08
2. T J Larsen, How 2 Hawc2, the user's manual, Risø-R-1597 (EN)
3. T J Larsen and T D Hanson. A method to avoid negative damped low frequent tower vibrations for a floating, pitch controlled wind turbine. Journal of Physics: Conference Series 75 (2007) 012073
4. H Markou and T J Larsen, Operation of Wind Turbines up to 50m/s – Controller and loads, Risoe-I-2857 (EN), 2009.