

NKS-B NordRisk: Nuclear risk from atmospheric dispersion in Northern Europe

Lauritzen, Bent

Published in:

Proceedings of the NKS-R and NKS-B Joint Summary Seminar

Publication date:

2009

Document Version

Publisher's PDF, also known as Version of record

[Link back to DTU Orbit](#)

Citation (APA):

Lauritzen, B. (2009). NKS-B NordRisk: Nuclear risk from atmospheric dispersion in Northern Europe. In Proceedings of the NKS-R and NKS-B Joint Summary Seminar (pp. 44-46). Roskilde: Nordisk Kernesikkerhedsforskning. (NKS-201).

DTU Library

Technical Information Center of Denmark

General rights

Copyright and moral rights for the publications made accessible in the public portal are retained by the authors and/or other copyright owners and it is a condition of accessing publications that users recognise and abide by the legal requirements associated with these rights.

- Users may download and print one copy of any publication from the public portal for the purpose of private study or research.
- You may not further distribute the material or use it for any profit-making activity or commercial gain
- You may freely distribute the URL identifying the publication in the public portal

If you believe that this document breaches copyright please contact us providing details, and we will remove access to the work immediately and investigate your claim.



Nordisk kernesikkerhedsforskning
Norrænar kjarnöryggisrannsóknir
Pohjoismainen ydinturvallisuustutkimus
Nordisk kjernesikkerhetsforskning
Nordisk kärnsäkerhetsforskning
Nordic nuclear safety research

NKS-201
ISBN 978-87-7893-269-3

Proceedings of the NKS-R and NKS-B
Joint Summary Seminar
Armémuseum, Stockholm, Sweden
26-27 March 2009

Justin P. Gwynn and Patrick Isaksson (Editors)
NKS

August 2009

Abstract

Nordic Nuclear Safety Research (NKS) is a platform for Nordic cooperation and competence in nuclear safety and related radiation protection issues including emergency preparedness and protection of the environment. Its purpose is to carry out joint activities producing seminars, exercises, scientific articles, technical reports and other types of reference material, with special efforts made to engage young scientists.

The region in question is the five Nordic countries, i.e., Denmark (including the Faroe Islands and Greenland), Finland, Iceland, Norway and Sweden, who share a common cultural and historic heritage. The Nordic countries have cooperated in the field of nuclear safety for approximately half a century, developing informal networks for exchange of information, strengthening the region's potential for fast, coordinated and adequate response to nuclear threats, incidents and accidents. Activities are financed and supported by Nordic authorities, research institutions, power companies, contractors and other organizations, with results used by participating organizations in their decision making processes and information efforts. The NKS-R and NKS-B Joint Summary Seminar held at the Armémuseum, Stockholm on the 26th - 27th of March 2009 showcased a range of activities supported by NKS over the previous 2 years and provided an opportunity to bring together researchers and end users from the wider NKS community. This summary seminar was the first joint venture between the NKS-R and NKS-B Programmes since the current two programme format was adopted by NKS. One of our intentions in organising the Joint Summary Seminar was to further the reciprocal awareness of ongoing research and issues under the respective NKS-R and NKS-B Programmes, with the aim of promoting new networking opportunities and generating new ideas and approaches to solving existing problems.

Key words

NKS, NKS-B, NKS-R, Nordic nuclear safety

NKS-201
ISBN 978-87-7893-269-3

Electronic report, August 2009

NKS Secretariat
NKS-776
P.O. Box 49
DK - 4000 Roskilde, Denmark

Phone +45 4677 4045
Fax +45 4677 4046
www.nks.org
e-mail nks@nks.org

**Proceedings of the NKS-R and NKS-B Joint Summary
Seminar
Armémuseum
Stockholm, Sweden
26th - 27th March 2009**

Justin P. Gwynn and Patrick Isaksson (Editors)

Foreword

Nordic Nuclear Safety Research (NKS) is a platform for Nordic cooperation and competence in nuclear safety and related radiation protection issues including emergency preparedness and protection of the environment. Its purpose is to carry out joint activities producing seminars, exercises, scientific articles, technical reports and other types of reference material, with special efforts made to engage young scientists.

The region in question is the five Nordic countries, i.e., Denmark (including the Faroe Islands and Greenland), Finland, Iceland, Norway and Sweden, who share a common cultural and historic heritage. The Nordic countries have cooperated in the field of nuclear safety for approximately half a century, developing informal networks for exchange of information, strengthening the region's potential for fast, coordinated and adequate response to nuclear threats, incidents and accidents. Activities are financed and supported by Nordic authorities, research institutions, power companies, contractors and other organizations, with results used by participating organizations in their decision making processes and information efforts.

The owners and main financiers of NKS are:

- Danish Emergency Management Agency
- Finnish Ministry of Employment and the Economy
- Icelandic Radiation Safety Authority
- Norwegian Radiation Protection Authority
- Swedish Radiation Safety Authority

Additional financial support is obtained from the following organizations:

- Fennovoima Oy in Finland
- Fortum Power and Heat Oy in Finland
- TVO in Finland
- IFE in Norway
- Forsmarks Kraftgrupp AB in Sweden
- Nuclear Training and Safety Center AB (KSU) in Sweden
- OKG AB in Sweden
- Ringhals AB in Sweden

The NKS-R and NKS-B Joint Summary Seminar held at the Armémuseum, Stockholm on the 26th - 27th of March 2009 showcased a range of activities supported by NKS over the previous 2 years and provided an opportunity to bring together researchers and end users from the wider NKS community. This summary seminar was the first joint venture between the NKS-R and NKS-B Programmes since the current two programme format was adopted by NKS. One of our intentions in organising the Joint Summary Seminar was to further the reciprocal awareness of ongoing research and issues under the respective NKS-R and NKS-B Programmes, with the aim of promoting new networking opportunities and generating new ideas and approaches to solving existing problems. As the NKS-R and NKS-B Programme Managers we would like to express our thanks to all the participants of the Joint Summary Seminar and in particular to those who presented NKS activities. In addition, we extend our thanks once again to all the organisations that contribute financial support to NKS, without which, such seminars would not be possible.

Patrick Isaksson
NKS-R Programme Manager

Justin Gwynn
NKS-B Programme Manager

Table of Contents

	Page
NKS-R AutoNewTech: Levels of automation and user control - evaluation of a turbine automation interface	1
<i>Jonas Andersson (Chalmers University of Technology)</i>	
NKS-R MOSACA: Safety culture - dimensions and evaluation	3
<i>Teemu Reiman (VTT)</i>	
NKS-B BIODOS: Biodosimetry application in emergency preparedness; NKS-B BIOPEX: Emergency preparedness exercise for biological dosimetry	7
<i>Carita Lindholm (STUK)</i>	
NKS-R StratRev: Stratification issues in the primary system. Review of available validation experiments and State-of-the-Art in modelling capabilities	10
<i>Johan Westin (Vattenfall Research and Development)</i>	
NKS-R POOL: Experiments and modelling of pressure suppression pools	13
<i>Timo Pättikangas (VTT)</i>	
NKS-B REIN: Slower decline in Chernobyl ¹³⁷Cs contamination in reindeer	17
<i>Lavrans Skuterud (Norwegian Radiation Protection Authority)</i>	
NKS-B GAPRAD: Filling knowledge gaps in radiation protection methodologies for non-human biota	21
<i>Justin Brown (Norwegian Radiation Protection Authority)</i>	
NKS-R NROI: Radiolytic oxidation of iodine in containment conditions	24
<i>Joachim Holm (Chalmers University of Technology)</i>	
NKS-R ExCoolSE: The study of multiscale multiphase phenomena in Nordic BWR - severe accidents	27
<i>Pavel Kudinov (Royal Institute of Technology (KTH))</i>	
NKS-B SPECIATION: Speciation analysis of radionuclides in the environment	31
<i>Xiaolin Hou (Risø DTU National Laboratory)</i>	
NKS-B HOT II: Radioactive particles in a Nordic context	35
<i>Brit Salbu (Norwegian University of Life Sciences)</i>	
NKS-R WERISK: Climate extremes in changing climate	38
<i>Grigory Nikulin (Swedish Meteorological and Hydrological Institute)</i>	
NKS-R PODRIS: Importance of inspection reliability assumptions on piping failure probability estimates	41
<i>Kaisa Simola (VTT)</i>	
NKS-B NORDRISK: Nuclear risk from atmospheric dispersion in Northern Europe	44
<i>Bent Lauritzen (Risø DTU National Laboratory)</i>	
NKS-B PardNor: Improved ingestion dose modelling for Nordic decision support	47
<i>Kasper Andersson (Risø DTU National Laboratory)</i>	

NKS-R WASCO: Wire system ageing assessment and condition monitoring	51
<i>Paolo Fantoni (IFE OECD Halden Reactor Project)</i>	
NKS-R IACIP: Comparison of VNEM to Measured Data from Ringhals Unit 3	55
<i>Makoto Tsuiki (IFE OECD Halden Reactor Project)</i>	
NKS-B GammaRate: Safe use of Portable gamma radiation ratemeters for environmental monitoring	58
<i>Linda Persson (Swedish Radiation Safety Authority)</i>	
NKS-B REMSPEC: Analysis of remotely accrued complex gamma ray spectra. A proficiency test	59
<i>Mark Dowdall (Norwegian Radiation Protection Authority)</i>	
NKS-R SafetyGoal: Probabilistic safety goals for nuclear power plants	63
<i>Michael Knochenhauer (Relcon Scandpower)</i>	
NKS-R RiskEval: Interpretation and risk evaluation of technical specification conditions	66
<i>Ola Bäckström (Relcon Scandpower)</i>	
NKS- B URBHAND: Handbook for Nordic decision support for contaminated inhabited areas	70
<i>Kasper Andersson (Risø DTU National Laboratory)</i>	
NKS-B LUCIA: Assessing the impact of releases of radionuclides into sewage systems in urban environment - simulation, modelling and experimental studies	73
<i>Synnöve Sundell-Bergman (Vattenfall Power Consultant)</i>	

NKS-R AutoNewTech: Levels of automation and user control - evaluation of a turbine automation interface

Jonas Andersson

Chalmers University of Technology, Sweden

jonas.andersson@chalmers.se

Automation technology has changed human activity in process control from manual work on the plant floor to distant supervisory control in control room environments. In the case of turbine operation in nuclear power plants, automation plays an important role. Automation offers many advantages in terms of stable control and efficiency and it also facilitates control room work by relieving the operator of continuous manual actions. However, automation has also shown to create a number of problems such as “out of the loop” performance problems, degradation of skills, automation surprises, brittleness and inappropriate trust. These effects all reduce operators’ ability to stay on top of their working situation and are directly connected to the design and level of automation applied in the technical system.

The purpose of this study was to examine how operator performance is affected by different levels of automation in nuclear power plant turbine operation. The aims were to investigate how the automatic turbine system (ATS) design support the turbine operators in their work in terms of monitoring and controlling the turbine process, and to identify possible improvements in the ATS user interface design.

The automatic turbine system consists of a series of sequences that can take the turbine equipment from an axis stand still to full operation, where the generator produces electricity to the grid. The automatic system can also be used in the reverse order to bring the turbine to a standstill. It is mainly used during turbine start-up and shut-down. This process takes place through seven main steps that contain approximately ten sub-steps each. The system can be utilized using three different levels of automation; manual, step-mode and fully automatic. Manual operation corresponds to separate control of each object in the sequences, whereas in step-mode the automation is used to perform sequences but the operator has to acknowledge each step. In full automation the operator only monitor the ATS user interface.

In the empirical field study, seven experienced nuclear power plant turbine operators were interviewed approximately one hour each to get their opinion of the ATS interface and what automation related problems they had experienced. The participating operators worked at the Oskarshamn 3 nuclear power plant. The interviews were performed during the annual operator training at the Studsvik nuclear power plant full-scope simulator facility in Sweden, where the operator teams performed training scenarios that included handling of the ATS. The interviews were recorded and transcribed to allow a correct analysis and avoid distortion of collected data. In addition to the interviews, a heuristic evaluation was performed to analyse the interface systematically. This assessment allowed a systematic analysis of properties in the ATS user interface that contributed to the automation related problems that were found through the interviews. The usability heuristics used in the evaluation were; consistency, compatibility, feedback, error prevention and recovery, user control, visual clarity, explicitness and prioritisation of functionality, and information.

The results showed that during manual control, the operators experience loss of speed and accuracy in performing actions together with difficulties to divide attention between performing a task and the overall monitoring of the turbine system status. According to the operators, the positive aspect of manual operations is an increased feeling of being in control when performing actions by hand. However, there is a trade off between the feeling of being in control and the speed and exactness of the automation. The operators handle this by using an intermediate step-mode, where they can take advantage of the speed of the automation at the same time as they maintain the feeling of control.

With higher levels of automation, the problems shift to issues concerning difficulty to follow the automatic sequences and losing track in procedures. The operators also state that it is hard to trouble-shoot failures in the ATS that have occurred when using a high level of automation. The difficulty of trouble-shooting an automatic system and reverting to manual control is a typical example of the “out of the loop” performance problem. When the level of automation gets higher, the information presentation becomes more important, since the operator needs to quickly assess the status of the automation.

The heuristic evaluation pointed out a number of usability related concerns in the ATS interface. Poor visibility of the automation’s underlying conditions was a major distress since it contributed to an opaque interface that worsened the difficulties of trouble-shooting automation failures. Another example of poor usability was inconsistencies between handling of unaccepted conditions and unaccepted alarms. This was also confirmed by the operators to have caused errors during manual operation.

The results of the interviews and the heuristic evaluation of the turbine automation interface point out that a number of automation related problems do exist. To address these issues in future designs will be a challenge, since complex interdependencies have to be presented. Increasing the observability of conditions and underlying program logic would be one measure to reduce the problems identified. To conclude, relevant information concerning the ATS status has to be provided together with the history of the automation as well as future actions. This is an important step to improve how the turbine automation user interface support the operators' ability to take over control when shifting from automatic to manual mode in case of a failure.

The final NKS report for the NKS-R AutoNewTech activity is available [here](#).

NKS-R MOSACA: Safety culture - dimensions and evaluation

Teemu Reiman

VTT, Finland

teemu.reiman@vtt.fi

Introduction

A sound safety culture is considered a cornerstone for nuclear safety. The concept was coined in an attempt to gain an overview and an indicator of the safety level of the organization. The concept tried to grasp the subjective and social factors (such as safety attitudes, management focus) affecting safety. The concept has been in use in the nuclear industry since Chernobyl accident in 1986. Yet no clear and widely accepted definition of safety culture and of the means to develop it exists. There are two main sources of confusion. First, the definitions of safety culture emphasize to varying degrees the attitudes, behaviour, or knowledge of the personnel, with some definitions placing emphasis on the structural features of the organization. This leads to very different ideas about the best means of developing safety culture. Second, the definitions of safety culture are often generic in nature, e.g. emphasising the importance of safety values or rigorous attitudes. Thus, they do not take into account the varying demands of different functions operating at the power plants, the features of the production technology, or the life-cycle of the given unit. How does safety culture manifest in a design organization or construction work? Should it be different in young companies in comparison to mature organizations or in waste management organizations in comparison to power companies? How does the original design of the plant affect the requirements for safety culture (cf. Rollenhagen, submitted)? Generic definitions of safety culture concept lead to overgeneralizations about what is the best safety culture and limited usefulness of the approach in actual safety improvement.

This project deals with the above mentioned limitations of our current understanding of safety culture concept and strives to clarify it with both theoretical and empirical evidence. The project aims at building and testing a model of safety culture which can be used as a background for developing an indicator of safety culture for both regulators and the power companies. Furthermore, an overview of the current nuclear safety culture in Finland and Sweden is obtained during the testing of the model in interviews and survey.

The goals of MOSACA 2008-2010 project are accomplished in several stages:

- Construct a model of safety culture (2008)
- Empirically clarify the central characteristics of safety culture in the Nordic nuclear industry (2009)
- Testing the model of safety culture in case studies (2010)
- Creating recommendations on safety culture evaluation and development (2008-2010)

Mosaca is carried out in collaboration between VTT, KTH (Carl Rollenhagen) and RiskPilot AB (Ulf Kahlbom). In 2009, there is additional cooperation with the University of Helsinki Department of Social and Moral Philosophy on the ethical and ontological aspects of safety culture.

Organizational culture and safety

In order to understand organizational safety, a model of an organization is needed. Organizational evaluation as well as organizational development is always driven by a model of how the organization functions and what to look for. Theories of safety culture seldom make explicit their underlying model of an organization, or their underlying model of system safety. We have tried to formulate such a model, and as a first step we have conceptualized organization as organizational culture. This means that we have taken culture as a root metaphor for organization (cf. Alvesson, 2002). The theoretical premise of our approach draws on interpretive-oriented theories of organizational culture. These theories share an interest in the meanings and beliefs the members of an organization assign to organizational elements (structures, systems and behavior) and how these assigned meanings influence the ways in which the members behave themselves (Schultz, 1995; Alvesson, 2002; Weick, 1995).

In the idea of culture as a root metaphor, “the social world is seen not as objective, tangible, and measurable but as constructed by people and reproduced by the networks of symbols and meanings that people share and make shared action possible” (Alvesson, 2002, p. 25). This means that even the technological solutions and tools are given meanings by their designers and users, which affect their subsequent utilization. It further means that concepts such as safety, reliability, human factors or organizational effectiveness are not absolute; rather organizations construct their meaning and act in accordance to this constructed meaning. For example,

if the organization socially constructs a view that the essence of safety is to prevent individuals - the weakest links in the system - from committing errors, the countermeasures are likely to be targeted at individuals and include training, demotion and blaming.

Organizational cultures are determined as much, if not more, by what they ignore (Weick, 1998) as by what they pay attention to and what they consider important and meaningful. In order to identify issues that are ignored, two things are needed; a) theory of system safety, and b) model of the main elements required to manage the organizational core task including taking care of the hazards (Reiman & Oedewald, in press b).

Dimensions of safety culture

We have outlined the main elements of organizational safety culture as being organizational dimensions, social processes, psychological properties and conceptions of the personnel and the organizational core task including the basic production technology (see also Reiman et al., 2008b; Reiman & Oedewald, in press a, in press b). The model depicts the organizational structures and processes that can be identified as influencing the personnel's capability and willingness for safety conscious behaviour. These are for example; risk management practices, training, resourcing, change management and supervisory activity (see Figure 1).

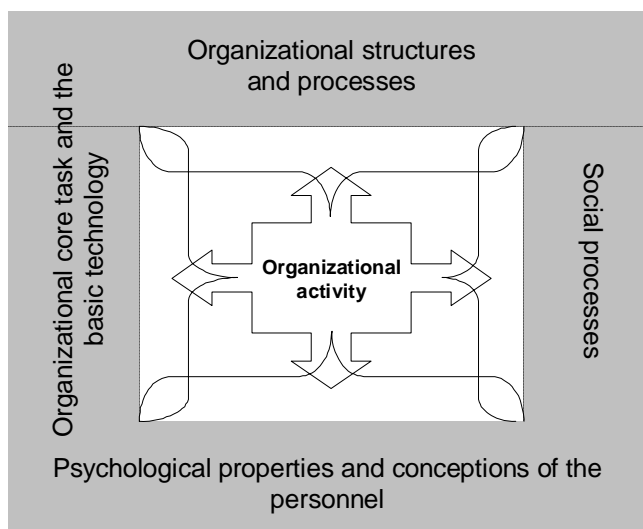

Figure 1. The four main elements of organizational culture define the frames of the organizational activity, which in turn influences the elements (Reiman & Oedewald, in press b).

The organizational dimensions are analytical tools for considering those aspects of organizational activity that can be intentionally managed and influenced. Organizational safety management is carried out through these dimensions. It is important to note that organizational dimensions are tools, not ends as such. They are tools to monitor and control the technology and the social processes and influence the psychological states of the personnel.

Social processes shape practices, create meaning and social order and facilitate change. Social processes manifest as intentional changes, unintentional variations, trade-offs, gradual local adjustments and reinterpretations of organizational activities and demands of work. Social processes can be seen as social mechanisms that “quietly” lead the organization to its current state of organizational and psychological dimensions. These processes include formation of social identity, optimizing of practices and sensemaking (cf. Weick, 1995; Snook, 2000) Social processes are the clue that makes culture a shared phenomenon (Reiman & Oedewald, in press b; cf. Rollenhagen, submitted).

The psychological properties such as sense of control and understanding of the organizational core task can be viewed as being the core element of an organizational safety culture. A measure of these dimensions indicates how well the personnel are currently coping with the demands of the organizational core task, and how much effort they have to exert to get to job done with sufficient quality. Whether or not these subjective perceptions of the personnel have a factual and objective content at the time of the perception, the effect they have on human performance is factual.

The organizational core task denotes the shared objective or purpose of organizational activity (e.g. guaranteeing safe and efficient production of electricity by light boiling water nuclear reactor). The physical

object of the work activity (e.g. particular power plant, manufacturing plant, offshore platform), the objective of the work, and the society and environment (e.g. deregulated electricity market, harsh winter weather) set constraints and requirements for the fulfilment of the organizational core task. The core task of the organization sets demands (constraints and requirements) for the activity and should be kept in mind when making evaluations of the organizational solutions or performance. The organizational core task has three main dimensions (Reiman, 2007):

- objective of work
- characteristics of the object of work
- external influences

The inherent hazards of the work are defined by the organizational core task. These in turn are interpreted within the organizational culture where the appropriate means to overcome the hazards are defined and carried out. Thus, the operational risk level of the organization is dependent on this subjective interpretation of the hazards.

Evaluation of safety culture

We state that an organization has a high potential for safety when safety is genuinely valued and the members of the organization are motivated to put effort on achieving high levels of safety, and it is understood that safety is a complex phenomenon (Reiman & Oedewald, in press a, b). Safety is understood as a property of an entire system and not just absence of incidents, people feel personally responsible for safety of the entire system, they feel that they can have an effect on safety, the organizations aims for understanding hazards and anticipating the risks in their activities, the organization is alert to the possibility of unanticipated events and there exists good prerequisites for carrying out the daily work.

One of the challenges in defining the criteria is that safety is a complex phenomenon that is not easy to define in measurable terms. Sometimes the definitions are simplistic in order to be able to more easily gather data on them, e.g. the number of workers without adequate personal protective equipment (negative indicator of safety culture) or the number times a manager visits the shop floor (positive indicator of safety culture) (Reiman et al., 2008a).

The crucial question at the evaluation of safety culture is how much is “good enough”? In other words, the evaluator needs to decide on the standards used to make judgments about the key findings (Reiman & Oedewald, in press a). Even if one has clinched a set of elements of organizational safety, the data always needs interpretation. There is no valid survey or interview technique that can provide a straightforward evaluation of such a complex phenomenon as organizational safety. For example, if one of the criteria in the evaluation were the employees’ understanding of hazards and the evaluator finds that almost all the interviewed employees do understand most of the hazards, but none understand all of them, is it reasonable to expect a perfect understanding? Can the level of understanding be said to be high if there are gaps in it?

Another crucial issue at this stage is the connection between various criteria. The main question is: does the organization have to be good on every criterion, or is it enough to score excellent on a few? For example, if the evaluator in the previous example found that the employees are highly motivated towards spending effort on safety (criteria), feel personally responsible for the safety of the plant (criteria) and have received good training on safety issues (criteria), but feel stressed and overburdened by work (criteria), should she count a mean value from three high, one moderate and one low score? Or should she write a qualitative judgment from all the available information, which includes a warning on the long-term effects of stress on performance and work practices? (see also Reiman et al., 2008a)

Continuation of the project in 2009-2010

During 2009 the goal is to empirically clarify the central characteristics and shared or differing viewpoints on safety culture in the Nordic nuclear industry. This is done as an interview study involving all the Nordic power companies, both regulators and several consultants and technical support organizations. In 2010, in-depth case studies are planned to be carried out at selected organizations. The aim of the case studies is to test the safety culture model and evaluate the level of safety culture at the case organizations. The model and theory on safety culture is revised according to the case results. During the duration of the entire project, an aim is to create advice and recommendations on safety culture evaluation and development in the nuclear industry.

Application of the results

Research contributes to the understanding of organizational factors and especially safety culture, and their relation to nuclear safety. The results of the project can be utilized in safety culture assessment and development initiatives carried out by the power companies, outside evaluators or the regulator. The project will create common guidelines for both power companies and regulators on how safety culture should be assessed and what regulations can be applied to it. The model of safety culture can provide clues for important dimensions to consider in the evaluation and as a guide in data collection and analysis. The model can also be used in integrating the various data that the power plant already has collected concerning e.g. their safety management system, safety climate, and job satisfaction. The safety culture model can be utilized in event investigations as a heuristic tool for considering the organizational, social and cognitive elements relevant to the event in addition to the situation specific factors. This consideration could shed more light on questions such as why the workers behaved as they did and why the organization failed in noticing the development of the incident. Finally, the results of the project can be utilized in assessing the safety implications of organizational changes. The possible safety effects of changes can be evaluated with the help of the dimensions depicted in the model.

References

- Alvesson, M. (2002). *Understanding organizational culture*. London: Sage.
- Reiman, T. (2007). *Assessing organizational culture in complex sociotechnical systems – Methodological evidence from studies in nuclear power plant maintenance organizations*. VTT Publications 627. Espoo: VTT.
- Reiman, T. & Oedewald, P. (2007). *Assessment of Complex Sociotechnical Systems – Theoretical issues concerning the use of organizational culture and organizational core task concepts*. *Safety Science*, 45, 745-768.
- Reiman, T. & Oedewald, P. (in press a). *Evaluating safety critical organizations. Focus on the nuclear industry*. Swedish Radiation Safety Authority, SSM.
- Reiman, T. & Oedewald, P. (in press b). *Framework for evaluating safety critical organizations*. In proceeding of the 17th World Congress on Ergonomics, IEA 2009, Beijing, China.
- Reiman, T., Rollenhagen, C., Kahlbom, U., Oedewald, P. & Wahlström, B. (2008a). *Conducting organisational safety reviews – requirements, methods and experience*. NKS-164. Nordic nuclear safety research, Roskilde.
- Reiman, T., Pietikäinen, E. & Oedewald, P. (2008b). *Turvallisuuskulttuuri. Teoria ja arviointi. [‘Safety culture. Theory and evaluation’]* VTT Publications 700. Espoo: VTT.
- Reiman, T., Rollenhagen, C., Kahlbom, U., Oedewald, P. & Pietikäinen, E. (in preparation). *MOSACA Final Report*. NKS.
- Rollenhagen, C. (submitted). *Can focus on safety culture become an excuse for not rethinking design of technology?*
- Schultz, M. (1995). *On studying organizational cultures. Diagnosis and understanding*. Berlin: Walter de Gruyter.
- Smircich, L. (1983). *Concepts of culture and organizational analysis*. *Administrative Science Quarterly*, 28, 339-358.
- Snook, S. A. (2000). *Friendly fire. The accidental shutdown of U.S. Black Hawks over Northern Iraq*. New Jersey: Princeton University Press.
- Weick, K.E. (1995). *Sensemaking in organizations*. Thousand Oaks: Sage.
- Weick, K.E. (1998). *Foresights of failure: an appreciation of Barry Turner*. *Journal of Contingencies and Crisis Management*, 6, 72-75.

NKS-B BIODOS: Biodosimetry application in emergency preparedness; NKS-B BIOPEX: Emergency preparedness exercise for biological dosimetry

Carita Lindholm¹, Wendla Paile¹, Daniela Stricklin² and Alicja Jaworska³

¹Radiation and Nuclear Safety Authority, STUK, Finland

²Swedish Defence Research Agency, FOI, Sweden

³Norwegian Radiation Protection Authority, NRPA, Norway

Carita.Lindholm@stuk.fi

Abstract

The BIODOS and BIOPEX studies have aimed at establishing a dose calibration curve for a feasible PCC-ring assay and to apply it in a simulated, mass casualty accident. The PCC assay was validated against the conventional dicentric assay. A linear relationship was established for PCC rings after ⁶⁰Co irradiation with doses up to 20 Gy. The testing of the PCC ring technique was performed by direct comparison to the conventional dicentric assay, both conducted with a triage approach that gives a crude dose estimate through analysis of a relatively small number of cells. Altogether 62 blood samples were analysed, each irradiated with an individual dose using ⁶⁰Co γ -rays, and representing casualties in a simulated radiation accident. Doses ranged from zero dose up to a lethal whole body dose of 13 Gy. The results indicated that both triage assays were capable of discerning non-exposed cases and that in the uniform irradiations, the dose estimates based on data from both assays were fairly consistent with the given dose. However, differences were observed depending on the dose level. At doses about 5 Gy and below, dicentric scoring resulted in more accurate whole-body dose estimates than PCC rings. At high doses, PCC rings appeared to give more accurate dose estimates than dicentrics. In non-uniform irradiations, neither assay enabled accurate estimation of either dose or fraction of cells irradiated. In conclusion, the study demonstrated that the PCC ring assay is suitable for use as a biodosimeter, although it is not superior to the dicentric assay. PCC rings are especially suitable for estimation of high doses.

Introduction

In the event of radiological accidents, a number of dose assessment techniques are available. Biological dosimetry provides an approach to determine the quantity of radiation exposure. When the number of casualties is large, there is a need for a method that allows for a fast and reliable dose evaluation that may be crucial for early decision of medical care. Biodosimetry also provides information on inhomogeneous exposure thus helping to recognize patients to develop severe local reactions. The classical dicentric method is generally considered the best of the biodosimetry methods, but it is relatively time-consuming and requires adequate training for successful determination of dose. Also, very high doses cannot be accurately assessed. Several biological techniques have challenged the dicentric method, one of them the PCC method, which is based on the analysis of cells where chromatin has been prematurely condensed with the help of either chemicals or fusion with mitotic cells from another species.

In the BIODOS project, our goal was to establish a feasible PCC assay for large scale radiological accidents. In the work performed during the BIOPEX project, the aim was to compare and validate the PCC ring assay with respect to the routinely applied dicentric assay in a triage mode.

Material and methods

BIODOS.

As the outcome of the BIODOS project, the PCC ring assay using okadaic acid was considered as the most feasible approach for mass casualty application among several tested assay variants. PCC ring frequencies were evaluated at both STUK and FOI for seven dose points and the data were fitted to a linear equation. Blood samples were exposed to ⁶⁰Co γ -rays with a dose rate of 0.3 Gy / min. Irradiations were performed in a water bath with a fixed temperature of 37 °C. Cultures were established using RPMI 1640 medium with 20% FCS, 1% PHA, 1% L-glutamine and 1% penicillin-streptomycin. A lymphocyte density of at least 0.5×10^6 cells / ml in 5 ml cultures was used. For dicentric assay, colcemid (final concentration 0.2 μ g/ml) was added for the last 2.5 h of the 48 h cultures. The PCC assay cultures obtained Okadaic acid (final concentration 500 nM) during the last 1 h of the 48 h cultures. Ring chromosomes were scored from PCC cells and the data were

fitted by the maximum likelihood method (Papworth 1975). Interlaboratory training and intercomparisons between STUK, FOI and NRPA were arranged in order to achieve uniform scoring criteria.

BIOPEX.

For the purpose of testing the PCC assay and the dicentric assay, a scenario of malevolent use of radiation was simulated by in vitro irradiation of blood samples. The scenario was based on the assumption that a very strong gamma source had been hidden in a public transport vehicle, giving rise to a dose rate of 20 Gy/h close to the source. Because of partial shielding it would be possible to get a high dose to only part of the body. In this scenario, 62 persons with clinical symptoms and potential exposure were evaluated. According to the scenario, the actual exposures spanned a broad spectrum of doses. Seven persons were supposed not to have been exposed at all, despite presenting with symptoms, while in the simulation, 37 persons were exposed to whole body doses between 0.4 Gy and 13 Gy. 18 cases received partial body doses of between 7 Gy and 13 Gy to between 10% and 40% of the body. These exposures were simulated by exposure of fresh blood to gamma radiation with a dose rate of 0.3 Gy/min. To simulate partial body exposure, exposed blood was mixed with unexposed blood from the same person in corresponding proportions. Similar culture conditions were used for BIOPEX as for BIODOS (see above). For dicentric assay, colcemid (final concentration 0.2 µg/ml) was added for the last 2.5 h of the 48 h cultures. From PCC preparations, the starting point was to analyse 50 rings or 500 PCC cells per sample, whereas 30 dicentrics or 50 metaphases were to be scored for the dicentric assay (Lloyd et al. 2000). Uniform analysis procedures were applied in both BIODOS and BIOPEX projects. STUK, FOI and NRPA all participated in the scoring of the 62 samples applying defined analysis criteria. Established calibration curves were used to estimate the doses based on PCC rings and dicentrics. For the latter, each laboratory used its own calibration curve. For samples irradiated in a partial body exposure scenario, the dose to the exposed fraction of cells was calculated by the Dolphin method (IAEA 2001).

Results and Discussion

The work performed in BIODOS and BIOPEX projects has aimed at establishing a biodosimetry technique for use in large accident involving exposure to low-LET ionizing radiation and to test the assay in a simulated mass casualty situation. PCC ring frequencies were evaluated at both STUK and FOI for seven dose points and the data were fitted to a linear equation to be used for dose assessment of large scale accidents. Similar results have been obtained in other PCC ring studies (Lamadrid 2007, Kanda et al. 1999).

The classic dicentric method was used as the reference technique to which the newly established PCC ring assay was compared. In general, the PCC ring assay was, depending on the dose, equally or somewhat less efficient than the dicentric assay in estimating correct dose in cases of uniform irradiations (Figure 1). Both triage assays were capable of discerning non-exposed cases. At doses about 5 Gy and below, dicentrics scoring resulted in more accurate whole-body dose estimates than PCC rings. At high doses, PCC rings appeared to give more accurate dose estimates than dicentrics. Applying the limited triage scoring, the dicentric assay was in 27 cases of 37 (with more than zero dose) capable of correctly placing cases in dose categories based on level of hospital care needed. For estimates from PCC ring scoring, the corresponding number was 21 out of 37.

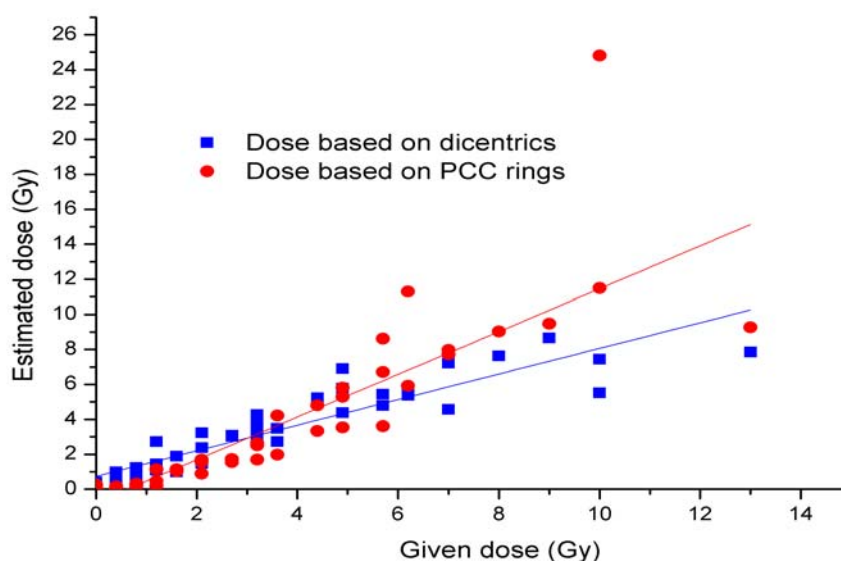

Figure 1. Simulated mass casualty: dose estimates for whole body exposures (44 cases) based on dicentrics or PCC rings.

In non-uniform irradiations, the PCC ring assay was slightly better in the approximation of the partial body dose than dicentrics, but neither was satisfactory. In addition, the fraction of cells irradiated could not be calculated with data from either of the assays. The difficulties in identifying non-uniform irradiation in this study originates mainly from the small number of cells analysed.

The assay of analysing PCC rings has proven to be a suitable method for estimating doses in an accident involving a large number of exposed casualties and is especially applicable of estimation of high doses. Based on the obtained data, the general conclusion is that the PCC ring and the dicentric assays are equally efficient biodosimeters.

Acknowledgements

We wish to thank the following persons at STUK: Pia Kontturi who performed blood sampling, Marjo Perälä who was responsible for blood handling and shipments, Armi Koivistoinen who took care of setting up and harvesting of cultures and the staff of Radiation Metrology Laboratory for performing the dosimetry and the irradiations. NKS conveys its gratitude to all organizations and persons who by means of financial support or contributions in kind have made the work presented in this report possible.

References

Durante M., George K., Yang T. C. Biological dosimetry by interphase chromosome painting. *Radiat. Res.* 1996,145: 53-60.

IAEA. Cytogenetic analysis for radiation dose assessment. IAEA Technical Report Series No. 405, IAEA, Vienna, 2001.

Kanda R., Hayata I., Lloyd D. C. Easy biodosimetry for high-dose radiation exposure using drug-induced, prematurely condensed chromosomes. *Int. J. Radiat. Biol.* 1999, 75: 441-446.

Lamadrid AI, García O, Delbos M, et al. PCC-ring induction in human lymphocytes exposed to gamma and neutron irradiation. *J. Radiat. Res.* 2007, 48: 1-6.

Lloyd D.C., Edwards A.A., Moquet J.E., Guerrero-Carbajal Y.C. The role of cytogenetics in early triage of radiation casualties. *Appl. Radiat. Isot.* 2000, 52: 1107-1112.

Papworth D.G. In Savage J.R.K. Sites of radiation induced chromosome exchanges. *Curr. Top. Radiat. Res.* 1970, 6: 129-194.

The final NKS report for the NKS-B BIODOS activity is available [here](#).

The final NKS report for the NKS-B BIOPEX activity is available [here](#).

NKS-R StratRev: Stratification issues in the primary system. Review of available validation experiments and State-of-the-Art in modelling capabilities

Johan Westin¹, Mats Henriksson¹, Timo Pättikangas², Timo Toppila³, Tommi Rämä³, Pavel Kudinov⁴ and Henryk Anglart⁵

¹Vattenfall Research and Development AB, Sweden

²VTT, Finland

³Fortum Nuclear Services Ltd, Finland

⁴KTH Nuclear Power Safety, Sweden

⁵KTH Nuclear Reactor Technology, Sweden

Johan.Westin@Vattenfall.com

Background and objectives

Thermal stratification of water can cause excessive thermal loads both in Boiling Water Reactors (BWR) and Pressurized Water Reactors (PWR). A recent example is the so-called “HTG-event” at Oskarshamn 3 in 2003, in which cold water was introduced near the bottom of the reactor pressure vessel (RPV) while the main coolant pumps were switched off. The natural circulation from the decay power did not provide sufficient mixing, and when the main coolant pumps were restarted a rapid temperature increase occurred near the lower plenum. Although no harmful thermal stresses occurred in this particular event, it is an example where the lack of understanding of physical processes could cause a serious damage to the reactor. The HTG-event is not unique, and similar incidents have occurred in other BWRs around the world.

There are several other examples of stratification issues which are relevant also for PWRs. Stratification in horizontal PWR surge lines is a well-known case in which hot water from the pressurizer passes over a layer with cold water, leading to time dependent temperature fluctuations and a risk for thermal fatigue. Another PWR-related example is stratification and insufficient mixing in the downcomer caused by the injection of cold water through the cold leg. This can lead to thermal striping and Pressurized Thermal Shocks (PTS) in the downcomer. Stratification and temperature fluctuations at pipe junctions with dead ends can also be a potential problem in which stratification is an important physical phenomenon. This case, which is valid both for BWR and PWR, becomes particularly important if the dead end is connected to a leaking valve that can cause a small supply of cold water.

The objective of the present project (StratRev) is to perform a review of available validation experiments and State-of-the-Art in modelling of stratification and mixing in the primary system of Light Water Reactors. The work is restricted to single-phase flow, but still the current topic covers a wide range of flow phenomena such as stratification, heat transfer, natural convection and buoyancy-driven flow, flow instabilities, turbulent mixing etc. Even laminar-turbulent transition can be of importance.

The project contains the following main tasks:

- Summarize known problems related to stratification and mixing phenomena in nuclear power plants. An import input to this task is the workshop on stratification that was organized as part of the StratRev-project. This will be further described in a separate section.
- Review existing experimental studies related to stratification in the RPV and the primary system piping.
- Review current modelling capabilities for stratification, natural convection and mixing relevant for the RPV and the primary system piping.
- Provide suggestions for possible continuation projects (research projects)

The project is ended and the work has been summarized in a written report.

BWR-OG Workshop on thermal stratification

A workshop on Thermal Stratification was organized within the StratRev-project in co-operation with BWR Owner’s Group (BWR-OG). The workshop was held in Älvkarleby, Sweden, June 3-4, 2008, and the workshop attracted more than 50 participants both from industry and academia and with different nationalities (Sweden, Finland, Germany, Switzerland, USA, England, Netherlands).

The first day of the workshop was mainly focussed on plant experiences related to thermal stratification phenomena, with presentations from different utilities. The presentations showed that the HTG-event in Oskarshamn is not a unique event, and a few similar cases were described. A number of other plant events related to stratification were also described. The majority of the presentations during the second day considered CFD-modelling of mixing and stratification.

The workshop ended with a final discussion focussing on whether there is a need for further analysis in this topic. A quite wide range of opinions were given, and below follows a summary of some of the comments:

- Stratification and mixing are important phenomena that can occur, and they can also affect the integrity of systems and components
- The analysis of the various thermal transients described at the workshop showed small usage factors (typically of the order of 0.001). Also when taking into account possible life time extensions it can be difficult to motivate further analysis based on these small usage factors.
- There is a general interest for improved understanding, for example:
 - What can cause stratification (forces that enhance stratification)?
 - What counteracts stratification (What is required to break-up a stratified layer?)
 - There is a need to analyze various types of events/scenarios in order to gain understanding
- The possibility to reduce operational restrictions can be a motivation for further analysis and research. For example, the possibility to avoid cold shutdown under certain circumstances, or the possibility to reduce current restrictions on the restart of the main circulation pumps, can both result in financial savings for the utilities.
- It is important with similar technical specifications and limitations in different plants
- There is a lack of knowledge and procedures that should be applied following this type of events.

Review of existing experimental studies and current modelling capabilities

In the review of existing experimental studies on stratification in the RPV, the references are divided into two categories: integral large-scale experiments and separate effect experiments. Experiments belonging to the first category are often designed to develop and test passive safety systems and for the assessment of system codes. Separate effect experiments are usually more suitable for model development and code validation. In order to be suitable for validation of methods based on Computational Fluid Dynamics (CFD), it is important that the boundary conditions are well-documented and that the results include some kind of flow field documentation (velocity measurements).

Thermal stratification in piping and in the RPV are inherently three-dimensional phenomena that are often localized both in space and time. Therefore, three-dimensional CFD calculations are needed in order to provide an accurate description. However, the computer time and the resources needed in construction of CFD models for complicated geometries limit the usability of CFD methods. How to make appropriate geometry simplifications is thus an important task in order to succeed when applying CFD-methods to the described stratification events. In many situations it is not even possible to use CFD-methods, and system codes are frequently used despite their limited capabilities of describing three-dimensional phenomena. Another important issue is the spatial distribution of the core power distribution and its influence on the flow patterns in the RPV.

Possible continuation projects

It is desirable to take actions in order to reduce the probability for stratification to occur, but also to develop well-validated and accepted tools and procedures for analyzing upcoming stratification events. The questions that should be considered to a greater extent are the following:

1. What is the possible impact of stratification events on the RPV structures?
2. What can be done to prevent the occurrence of thermal transients?
3. What means should be taken in case of a stratification event?

A fairly ambitious research plan has been outlined in the final report of the project covering the above questions, but also a few suggestions regarding more limited research activities have been given. The ultimate goal is to establish Best Practice Guidelines that can be followed both by utilities and authorities in case of an event including stratification and thermal loads.

An important activity that requires further attention is validation of different computational methods with relevant test cases. Since many of the stratification events results in thermal loads that are localized in time and space, CFD is a (the) suitable tool. However, the often very large and complex geometry implies that CFD cannot be applied to the entire RPV. When possible it is desirable to divide the problem in smaller domains that can be analyzed with CFD, and it is also important to perform a step-by-step increase in complexity with intermediate validation versus relevant experimental data.

The fact that CFD cannot be applied to the entire RPV also emphasizes the importance of other methods that can be applied to this type of flow problems. For example modelling the complicated flow inside the reactor core is such a problem that is not feasible today with current CFD-methods, and it is thus important to continue to develop and validate integral methods that can be applied. It is also important to use a statistical approach to quantify modelling uncertainties.

Concluding remarks

The presentations given by different utilities at the stratification workshop showed that stratification issues are not unusual, and a number of different examples were given. However, the analysis of the different thermal transients all showed small usage factors, which raised questions whether current high-temperature alarms and operating restrictions after pump trips are relevant. Nevertheless, it is a fact that uncontrolled thermal transients have caused long and costly production stops during the period when the possible safety effects of the transients are analyzed, and it is likely that such events will occur also in the future.

Today there is a lack of knowledge and procedures that should be applied in case of upcoming stratification events, and the ultimate goal is to establish Best Practice Guidelines that can be applied. This requires validation and assessment of currently available computational tools.

A fairly ambitious research plan has been outlined in the final report, but also a few suggestions regarding more limited research activities have been given. The reference group of NORTHNET Roadmap 2 has recently been requested to provide a ranking of the suggested continuation projects in order to identify the projects/tasks that they consider to be important.

NKS-R POOL: Experiments and modelling of pressure suppression pools

T.J.H. Pättikangas¹, J. Niemi¹, A. Timperi¹, M. Puustinen², J. Laine², A. Räsänen², Hua Li³ and P. Kudinov³.

¹VTT Technical Research Centre of Finland

²Lappeenranta University of Technology, Finland

³Division of Nuclear Power Safety, Royal Institute of Technology (KTH), Sweden

timo.pattikangas@vtt.fi

Introduction

In a hypothetical loss-of-coolant accident (LOCA), a large amount of vapor is released after a break of a main steam line into the drywell compartment of a Boiling Water Reactor (BWR). When pressure increases in the drywell compartment, air and vapor flow through vent pipes into a wetwell compartment. The vent pipes are submerged in a pressure suppression pool, which changes a large volume of vapor into a small volume of water.

In the POOL project, the thermal hydraulic phenomena and the pressure loads in the drywell and wetwell compartments are studied. Experiments are performed with the pressurized PPOOLEX facility at the Lappeenranta University of Technology (LUT) [1]. PPOOLEX consists of down-scaled models of drywell and wetwell compartments. At VTT, Computational Fluid Dynamics (CFD) and Finite Element (FE) modelling of the experiments is performed [2]. Modelling of thermal stratification experiments of the water pool with the GOTHIC code is done at the Royal Institute of Technology [3]. The NKS-R project POOL is reviewed in the following.

Experiments with the PPOOLEX facility

A test facility including adequate models of the drywell and wetwell compartments and withstanding prototypical system pressure (0.5 MPa) has been taken in use at LUT in 2007–2008 (Figure 1). Wall condensation in the drywell and direct-contact condensation in the wetwell can be examined and scenarios in terms of condensation modes, as well as thermal stratification threatening the integrity of pool structures can be studied. Investigation of the steam/gas injection phenomenon requires high-grade measuring techniques. Therefore, a kHz-range data acquisition system and high speed cameras are employed.

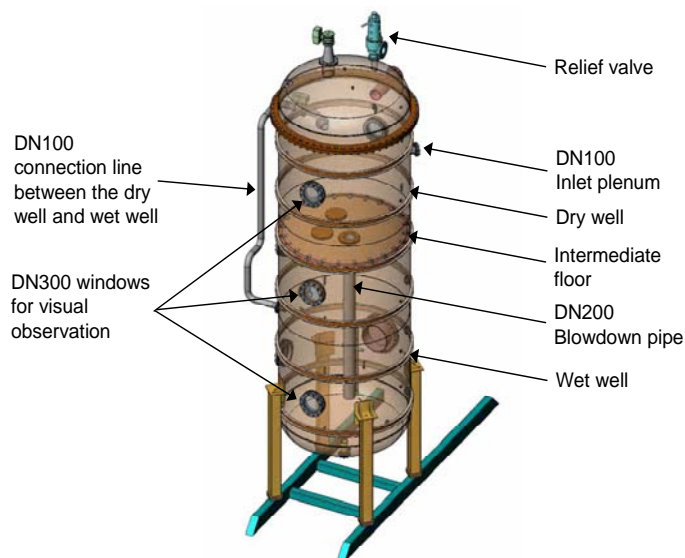

Figure 1. PPOOLEX test facility.



Figure 2. Collar of the blowdown pipe.

A series of characterizing experiments with air/steam discharge was carried out in 2007 to observe the general behaviour of the facility. Experiments on the discharge of non-condensable gas (air) to the drywell compartment and from there through one blowdown pipe into the condensation pool related to the very first seconds of a postulated large-break LOCA inside the containment were also conducted in 2007. Wall condensation in the drywell compartment was studied and verification data for CFD calculations at VTT produced in 2008. Experiments to investigate the effect of a collar attached to the blowdown pipe outlet on the pressure loading of the pool were carried out in the beginning of 2009 (Figure 2).

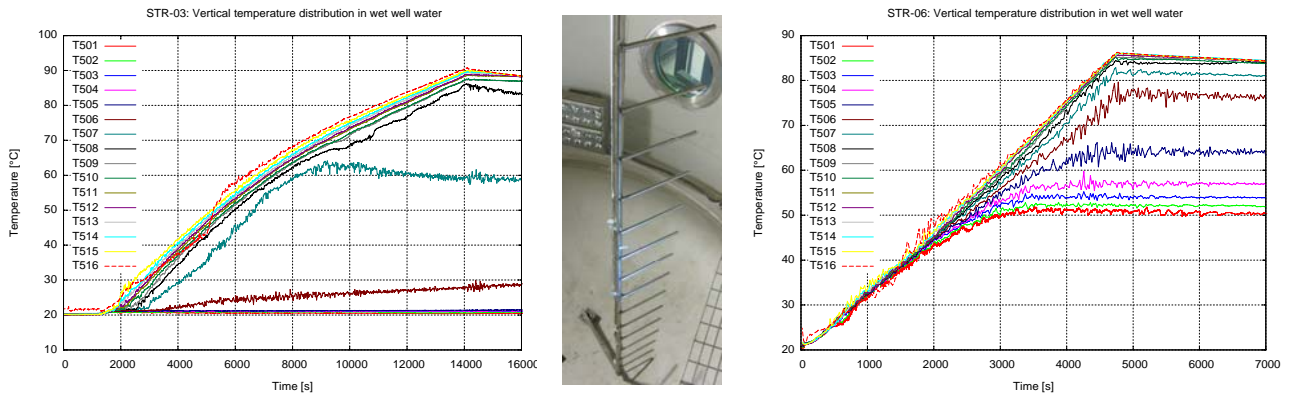

Figure 3. Effect of steam discharge rate on mixing and development of stratification in the wet well pool. On the left, steam mass flux in the blowdown pipe is about 2.2 kg/sm² and on the right, about 5.6 kg/sm².

In the thermal stratification experiments in 2008, the effect of steam discharge rate on mixing and development of stratification layers in the pool volume was of interest (Figure 3). In addition, verification data for GOTHIC calculations at KTH were produced. Several thermocouples were added to the pool based on the information from the pre-calculations by KTH in order to measure accurately the characteristics of thermal stratification and mixing.

CFD and FE modeling of the pressure loads

The PPOOLEX experiments have been modelled with CFD and FE calculations. Discharges, where only air is blown into the drywell, have been modelled by using the Volume Of Fluid (VOF) model of the commercial FLUENT CFD code. The VOF model is based on tracing the interface between gas and water and it is suitable for describing large bubbles in the water pool. Discharges where vapour is blown into the drywell have been modelled by using the Euler-Euler multiphase model of FLUENT, which can describe well the behaviour of small bubbles. Wall-condensation model and a simple version of direct contact condensation model have been implemented in FLUENT by using user-defined functions.

In Figure, temperature in the PPOOLEX device is shown at different instants of time in an experiment, where air is blown into the drywell. When pressure increases inside the vessel, the temperature also increases because of adiabatic compression of the gas. In the gas space of the wetwell, strong thermal stratification occurs because of density differences of hot and cold air.

The pressure loads and the strains and displacements of the pool structures have been analyzed by performing Fluid-Structure Interaction (FSI) calculations of the PPOOLEX experiments. In FSI calculations, motion of the structures is taken into account when the pressure loads are calculated. The Star-CD code is used for CFD and the ABAQUS code for structural analysis. The codes are coupled by using the MpCCI middleware. Calculations of the experiments have been numerically unstable with the explicit FSI coupling scheme of MpCCI. Therefore, a linear perturbation method has been developed and validated for preventing the instability.

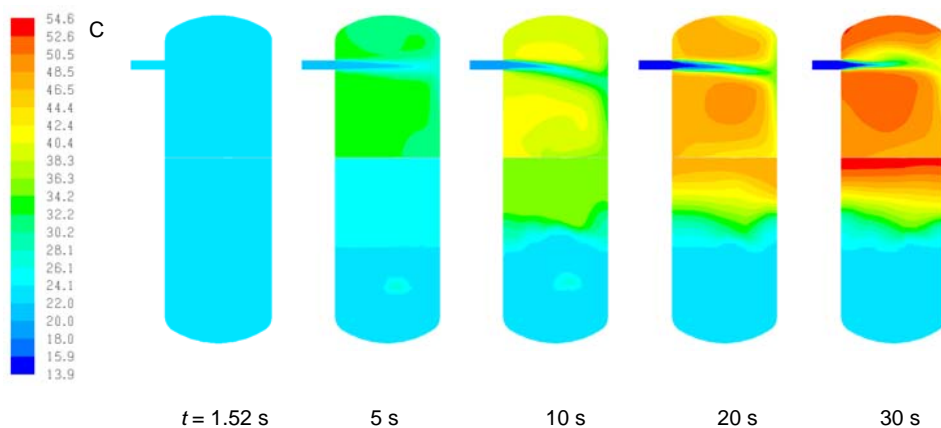

Figure 4. Formation of thermal stratification in the gas space of a PPOOLEX experiment, where air is blown into the pressurized facility. CFD simulation is performed with the FLUENT code.



Figure 5. Formation of gas bubble at the vent outlet in the pressure suppression pool. Comparison of FSI calculation to experimental results obtained at PPOOLEX facility.

When pressure increases in the drywell, air is blown through the vent pipe into the water pool of the wetwell. In Figure 5, FSI calculation of formation of the first air bubble in the water pool is compared to an experimental result at different instants of time. The simulation results show that it is necessary to take into account fluid-structure interaction in calculation of the pressure load. Ignoring FSI leads to qualitatively incorrect results for the wall pressure in the PPOOLEX facility.

Prediction of thermal stratification and mixing in the pool

Reliable prediction of the pool thermal-hydraulics including thermal stratification and mixing phenomena presents a computational challenge. First of all, lumped-parameter models fail to provide consistent description of thermal stratification. One-dimensional models have problems with taking into account of real geometry of the nuclear power plant pool. On the other hand, high-order-accurate CFD (RANS, LES, DNS) methods are not practical in engineering analysis due to excessive computing power necessary to calculate 3D high-Rayleigh-number natural convection flows, especially in long (~hours) transients.

GOTHIC was selected as appropriate tool in the present project because it combines system code features with lumped volumes and semi-empirical correlations for heat and mass transfer processes with CFD-like approach with distributed parameter model which allow us to resolve spatial flow and temperature fields.

For assessment of the reliability of GOTHIC in predicting thermal stratification, validation of the code was performed against POOLEX experiments. Lumped parameter model of GOTHIC was used for prediction of heat balance and heat losses in the open pool experiment POOLEX STB-20 to define boundary conditions necessary for the 2D distribution parameter simulations [3].

In Figure 6, results of grid convergence study and comparison with experimental results are presented for 2D GOTHIC simulation of stratification. Several grids were used for grid convergence study. Further analysis was performed with grid 48×118 which gives reasonable balance between accuracy of the analysis and computational time. In Figure 7, development of stratification in the pool during steam injection and cooling phase with no steam injection are shown. One can see in Figure and Figure that GOTHIC code can reliably predict thermal-hydraulics of the pool and thermal stratification.

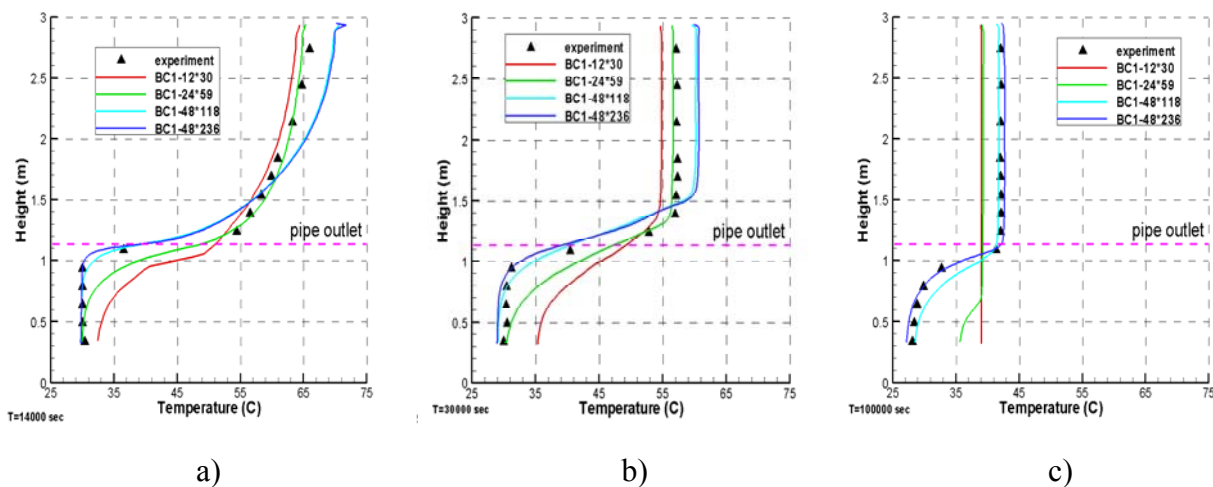

Figure 6. Grid convergence and comparison with experimental data for vertical temperature distribution at different times. Grids used 12x30, 24x59, 48x118, 48x236. a) 14000 sec; b) 30000 sec; c) 100000 sec.

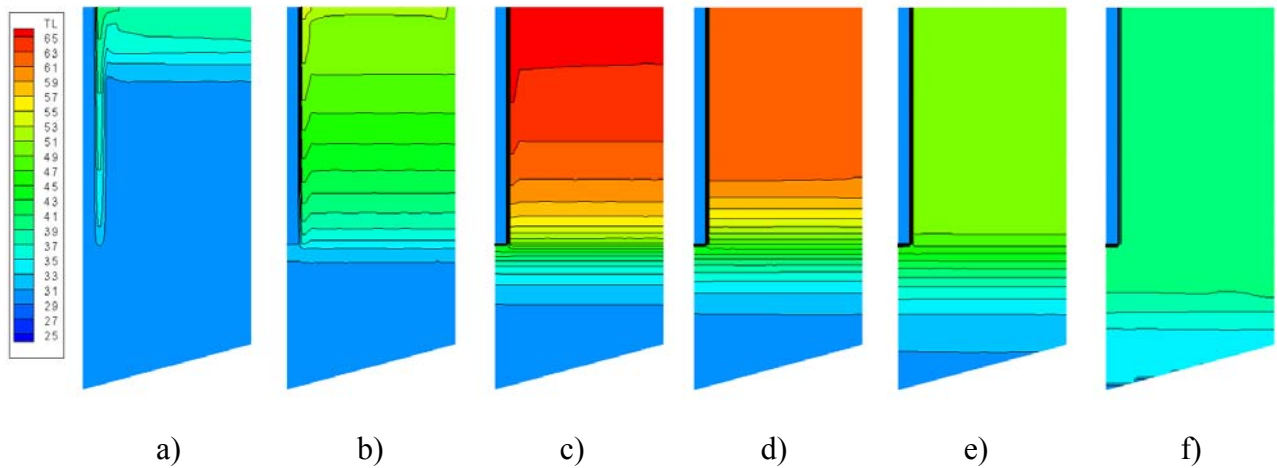

Figure 7. Development of stratification (0-14600 sec) during steam injection and cooling phase with no steam injection (14600-100000 sec): a) 500 sec; b) 5000 sec; c) 14600 sec; d) T=20000 sec; e) T=50000 sec; f) 100000 sec.

Summary and discussion

In the NKS-R project POOL, thermal hydraulic phenomena and pressure loads in a pressure suppression containment of a BWR are studied. Experiments have been performed with the pressurized PPOOLEX facility with air and steam discharges. Experiments have provided data on wall condensation in the drywell and on the behaviour of air and steam in the water pool of the wetwell. Thermal stratification has been studied at different mixing conditions of the water pool.

The Volume Of Fluid model has been successfully used for CFD simulation of air discharges in the PPOOLEX device. The main features of the bubble dynamics in the water pool are fairly well described in the simulation model. The wall condensation model implemented in the Euler–Euler CFD model has been tested and promising results have been obtained. The fluid-structure interaction calculations have shown that FSI effects have to be taken into account in order to obtain realistic results for the PPOOLEX experiments.

GOTHIC code validation against POOLEX experiments shows reasonable accuracy in prediction of thermal stratification in a pool during long (tens of hours) transients. In the next step, validation of GOTHIC will be performed against PPOOLEX data with stratification and mixing in the pool for the case of high mass flux of steam blowdown.

References

- [1] J.Laine and M.Puustinen, Report NKS-168, 33 p. (2008).
- [2] T.Pättikangas, J.Niemi and A.Timper, VTT Research Notes 2466, pp. 160–172 (2009).
- [3] H.Li and P.Kudinov, NUTHOS-7, Seoul, Korea, October 5-9, 2008, Paper 243.

The final NKS report for the NKS-R POOL activity is available [here](#).

NKS-B Rein: Slower decline in Chernobyl ^{137}Cs contamination in reindeer

Lavrans Skuterud¹ and Birgitta Åhman²

¹Norwegian Radiation Protection Authority and Norwegian Reindeer Husbandry Administration

²Swedish University of Agricultural Sciences, Faculty of Veterinary Medicine and Animal Science, Reindeer Husbandry Unit

Lavrans.Skuterud@nrpa.no

Introduction

Reindeer husbandry is the part of Nordic food production most vulnerable to radioactive contamination. The Chernobyl fallout had dramatic consequences for reindeer husbandry in central Sweden and central and southern Norway, and still (in 2009), twenty-three years after the Chernobyl accident, monitoring and countermeasures are required in 10 Norwegian and 16 Swedish reindeer herding districts before animals can be slaughtered for trade (i.e., contain less than 3000 Bq kg⁻¹ in Norway and less than 1500 Bq kg⁻¹ in Sweden).

The supposedly one-year long NKS-B project “Regional differences in reindeer radiocaesium contamination” (REIN) was initiated in 2004 with the aim of reviewing the long-term data on radiocaesium in reindeer and studying potential regional differences in food-chain radiocaesium transfer. For various reasons there have been a number of delays in the project. However, the slow progress has made possible the identification of a much slower decline in radiocaesium concentrations in reindeer during the last years compared to the first 10-15 years after the Chernobyl fallout. The current slower decline in contamination levels in Scandinavian reindeer is the focus of this abstract.

Long-term trends in radiocaesium concentrations in reindeer

Following the Chernobyl fallout, average radiocaesium concentrations in reindeer in central Sweden and Norway reached 40-50 kBq/kg, about an order of magnitude higher than the highest concentrations observed in the 1960s after the nuclear weapons fallout.

During the first ~10 years after the accident, the ^{137}Cs concentrations in reindeer in winter declined with effective half-times of 3-5 years (Åhman and Åhman, 1994; Gaare et al. 2000; Skuterud et al., 2005). This rate of decline was similar to that observed in lichens (Gaare et al., 2000; Åhman, 2005; Lehto et al., 2008), and reflected the role of contaminated lichens in the diet of reindeer. However, from the mid 1990s onwards slower rates of decline in reindeer were observed both in Sweden and Norway (Åhman et al., 2001; Skuterud et al., 2005).

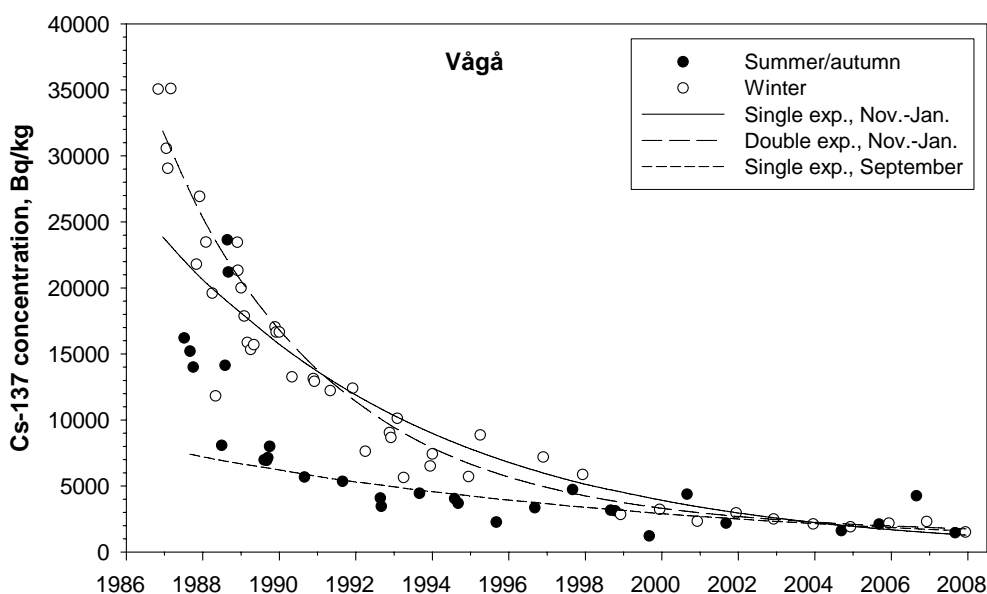

Figure 1. Average ^{137}Cs concentrations in autumn and early winter in reindeer in the Vågå reindeer herding district (Norway). • indicates observed concentrations during July-October; o indicates concentrations observed during November-May. The curves are fitted single- and double-exponential models to values observed during September and November-January, respectively (data from the Reindeer Husbandry Administration; results for the period up to 2003 were presented in Skuterud et al. (2005)). See Table for parameter details.

Table 1. Estimated effective half-times (\pm standard error) for ^{137}Cs in reindeer during different seasons in the Vågå herd. T_{eff} (1-10) and T_{eff} (10-20) give estimated half-times during year 1-10 and 10-20 after the Chernobyl accident, respectively.

Herding district	Season	T_{eff} (all years), year	T_{eff} (1-10), year	T_{eff} (10-20), year	Double-exponential model	
					$T_{\text{eff}1}$, year	$T_{\text{eff}2}$, year
Vågå	September	9.2 \pm 2.1	4.10 \pm 0.64	No decline	-	-
	Nov-Jan	4.99 \pm 0.29	3.91 \pm 0.42	6.6 \pm 1.5	2.98 \pm 0.87	27 \pm 84 (ns)

Figure 1 illustrates the ^{137}Cs concentrations in reindeer of one of the best studied Norwegian herding districts, and Table 1 gives various estimated effective half-times for ^{137}Cs in these animals from 1986 onwards. There has been no significant decline in concentrations in reindeer in this district in autumn from the mid 1990s. Furthermore, the winter contamination levels during 1986-2007 were best approximated by a double-exponential model with short- and long-term half-times of about 3 and 27 years (the latter not being statistically significant).

As indicated in Fig. 1, the systematic and pronounced increase in ^{137}Cs concentrations in reindeer from autumn to winter observable the first years after the Chernobyl fallout disappeared in Vågå by the late 1990s. A plausible explanation is that the initially large difference in contamination levels in the dietary items lichens and green plants had been reduced due to the continuous decline in contamination levels in lichens. Different species of green plants show different long-term trends in ^{137}Cs contamination, and in some species the decline is non-detectable a few years after fallout (e.g., Rissanen et al., 2005). Consequently, in the long-term contamination levels in reindeer will be governed by the dietary components with the slowest decline. However, the reindeer's slower excretion of radiocaesium during winter (Holleman et al. 1971) will be expected to increase their body concentrations in this season even when the summer and winter diets have similar radiocaesium concentrations.

In the comprehensive study of long-term trends in ^{137}Cs concentrations in Swedish reindeer herds in various seasons, Åhman (2007) showed that the effective half-time during the first 10 years after the Chernobyl accident was considerably shorter than in the period 10-20 years after the accident. An aggregated analysis of all the Swedish herds resulted in average effective half-times for the season November-December of about 3.5 and 7 years during the periods 1-10 and 10-20 years after the Chernobyl accident, respectively (Åhman 2007), corresponding to the values for the Norwegian herd above.

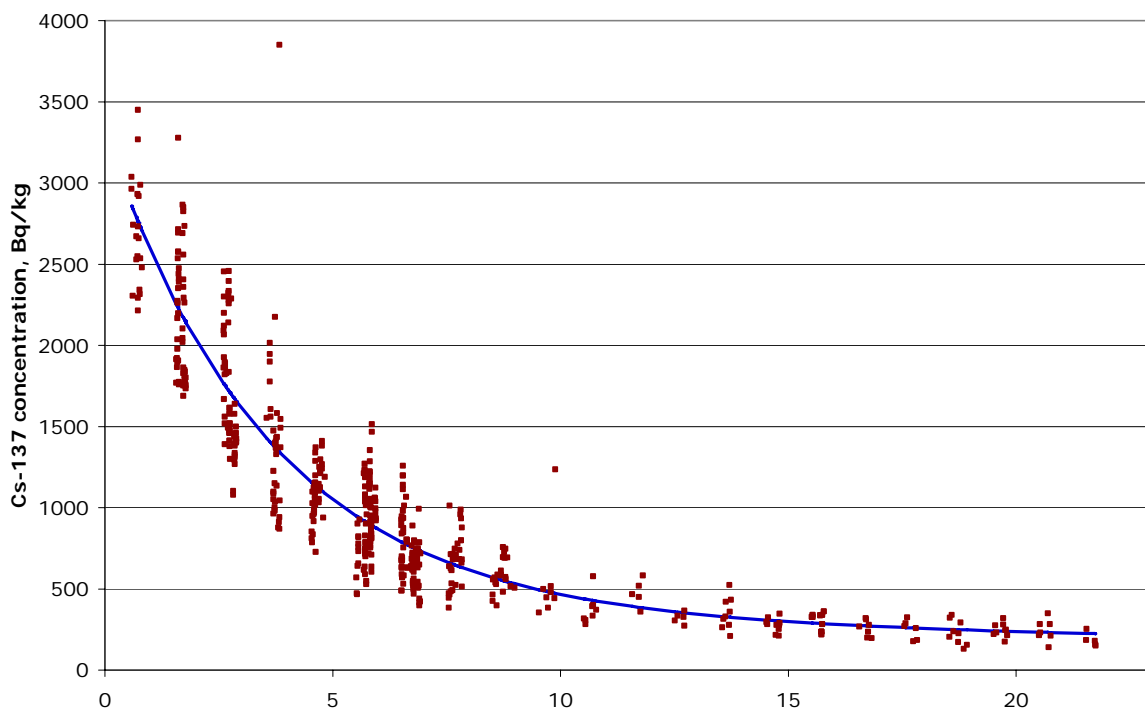

Figure 2. Concentrations of ^{137}Cs in reindeer from the five Swedish herding districts Idre, Ruhvten, Mittådalen, Handölsdalen and Tåssåsen during winter (November-April). The values of each district have been corrected for differences in contamination levels and pooled (see text for details). Each dot is average of minimum 10 animals (usually 30 animals). The curve is a fitted double-exponential model with half-times of 2.5 and 30.8 years (standard error intervals: 2.20-2.87 and -32.8-10.5).

Figure 2 presents an analysis of concentrations in reindeer during winter in the five southernmost Swedish herding districts. Linear regression with log transformed concentration values were used to quantify differences in contamination levels between the districts. Thereafter the concentration values in the various districts were normalized before fitting a double-exponential model to the pooled dataset. The parameters of the double-exponential model indicate that the ^{137}Cs concentrations in reindeer during winter declined with short- and long-term effective half-times of 2.5 and 30.8 years, respectively. However, as for the Norwegian herd above, the decline of the slow component is not statistically significant.

As opposed to the situation in the Norwegian herding district presented above, there are still pronounced seasonal variations in ^{137}Cs concentrations in reindeer in most of the Swedish herds studied by Åhman (2007). In some districts this may be a result of migration to areas of higher deposition in winter.

A general lack of relevant time-series vegetation data is a limitation in the analysis of long-term trends in radiocaesium concentrations in reindeer. In the model development by Åhman (2007) this was solved by including two groups of unknown vegetation with different transfer values and half-times. The modelling results showed that the dietary components mainly governing the radiocaesium concentrations in reindeer during winter was lichens (71 % of the diet; with an effective ecological half-time of 3 years) and an introduced group of “unknown vegetation” (called Veg II) which comprised 6 % of the diet and had an effective half-time of 30 years. This half-time corresponds well with that observed in the Norwegian and Swedish herds above.

Conclusions

The underlying processes (i.e., the change in significance of lichens and plants to the intake of ^{137}Cs by reindeer) suggest that exponential models with more than one time-dependent component will reasonably describe long-term trends in radiocaesium contamination in reindeer. This is supported by the analysis by Åhman (2007). However, due to the variability in the concentrations in reindeer it may be difficult to identify statistically significant components of such models, and methodologically this approach may therefore be questionable. In the REIN project we nevertheless chose double-exponential models as base models, as they are ecologically reasonable.

The analyses of trends in ^{137}Cs in Scandinavian reindeer performed in REIN suggest that concentrations currently decline with half-times of about 30 years. I.e., it appears that the physical decay of ^{137}Cs is now the process dominating the long-term trend. This time-trend indicates that countermeasures and monitoring of reindeer in the contaminated areas of Sweden and Norway will probably be needed for at least another 10 to 20 years.

The persistent contamination problems in Swedish and Norwegian reindeer herding warrant further studies into the long-term soil-to-plant transfer of radiocaesium in relevant vegetation species. Further elucidation of the long-term ^{137}Cs trends in reindeer requires such studies.

References

- Gaare E, Skogen A, Strand O (2000). Monitoring ^{137}Cs in the Dovre-Rondane region 1997-1999. NINA Oppdragsmelding 616. Norwegian Institute for Nature Research, Trondheim (in Norwegian, English abstract).
- Holleman D F, Luick JR, Whicker FW (1971). Transfer of radiocaesium from lichen to reindeer. *Health Phys.* 21:657-666.
- Lehto J, Paatero J, Pehrman R, Kulmala S, Suksi J, Koivula T, Jaakkola T (2008). Deposition of gamma emitters from Chernobyl accident and their transfer in lichen–soil columns. *Journal of Environmental Radioactivity* 99:1656-1664.
- Rissanen K, Åhman B, Ylipiö J, Nylén T (2005). Radiocaesium in reindeer pasture. Abstract. In: Valentin J, Cederlund T, Drake P, Finne IE, Glansholm A, Jaworska A, Paile W, Rahola T (eds). *Radiological Protection in Transition – Proceedings of the XIV Regular Meeting of the Nordic Society for Radiation Protection, NSFS – Rättvik, Sweden, 27–31 August 2005*. Stockholm: Swedish Radiation Protection Authority. SSI Rapport 2005:15, 307-310.
- Skuterud L, Gaare E, Eikermann IM, Hove K, Steinnes E (2005). Chernobyl radioactivity persists in reindeer. *Journal of Environmental Radioactivity* 83:231-252.

Åhman B, Åhman G (1994). Radiocesium in Swedish reindeer after the Chernobyl fallout: Seasonal variations and long-term decline. *Health Physics*. 66 (5):503-512.

Åhman B, Wright SM, Howard BJ (2001). Effect of origin of radiocaesium on the transfer from fallout to reindeer meat. *Science of the Total Environment* 278, 171-181.

Åhman B (2005). Development, control and countermeasures regarding radioactive caesium in Swedish reindeer after the Chernobyl accident (in Swedish, English summary). Swedish Radiation Protection Authority, Stockholm. SSI rapport 2005:17.

Åhman B (2007). Modelling radiocaesium transfer and long-term changes in reindeer. *Journal of Environmental Radioactivity* 98:153-165.

The final NKS report for the NKS-B REIN activity is available [here](#).

NKS-B GAPRAD: Filling knowledge gaps in radiation protection methodologies for non-human biota

Justin Brown and Runhild Gjelsvik
Norwegian Radiation Protection Authority, Norway.
justin.brown@nrpa.no

Introduction

The GAPRAD activity - Filling knowledge gaps in radiation protection methodologies for non-human biota funded as part of the NKS B-programme started in May 2007 and was completed by December 2008. The activity has been conducted as a collaborative effort between the Norwegian Radiation Protection Authority, University of Lund in Sweden, RISØ national laboratory in Denmark and Nuclear Safety Authority (STUK) in Finland. The main aim of the activity was to identify data on activity concentrations of Po-210 in soil, plants, invertebrates and small mammals. In addition, there were plans to measure concentration of natural radionuclides like U-238, U-234, Ra-226, Ra-228, Po-210, Pb-210 in fish, brackish waters and sediments where practicable and to attain new information on gastrointestinal uptake and residence time in mammals (using "man" as the reference species) through experimentation.

Setting the scene

The deliverable report "Knowledge gaps in relation to radionuclide levels and transfer to wild plants and animals, in the context of environmental impact assessments, and a strategy to fill them." (Brown, 2009) sets the scene for the work conducted in the GAPRAD project. The objective of the deliverable report was to provide an overview of the coverage of information available in relation to radionuclide levels for natural radionuclides and transfer in the environment, within the context of established environmental impact assessment frameworks. In this way, knowledge gaps can be easily identified. Once this initial step had been taken the second objective was to formulate a strategy concerning how these information gaps might be filled, thereby providing a roadmap for a further study within this NKS Research Project.

The method applied for the deliverable report was simply to access databases and reviews conducted recently in the context of the development of environmental impact assessment approaches. The focus of the work was on natural decay series radionuclides (^{238}U and ^{232}Th decay series radionuclides with half-lives > 10 days¹).

This entailed:

- Summarising information from the ERICA project (see Larsson, 2008): three empirical databases have been collated within the ERICA project with respect to terrestrial, freshwater and marine ecosystems. These data were analysed in the study to provide an overview as to where data gaps exist.
- Analyses of other recently published data

Consideration of the transfer databases in ERICA for the terrestrial environment shows that the coverage for Pb is reasonable presumably reflecting the large number of stable element studies that have been conducted on this element. Other radioelements are more poorly characterised with empirical data sets. In the case of polonium, some information is available for flora but are very limited for fauna where only data on a few species of mammals are available. In the latter case it should be noted that although 36 data are available these represent all mammals from a single geographical area - the UK, and these are largely on data for mammals forming components of the human diet. The number of values associated with thorium is low. In all cases the number of available empirical values is below 20 and for seven reference categories no information is available at all. A similar situation exists for uranium, although arguably, floral reference organisms are endowed with reasonable CR information. For radium there are severe data deficiencies for invertebrates e.g. insects and vertebrates like amphibia and reptiles. The data coverage for Pb in the ERICA transfer database for freshwater ecosystems is extremely poor – no data are available for any reference organism although it may be assumed that an extended review of stable element data might lead to the extraction of at least some information to mitigate this situation. CR values for Th are limited to a small number of data for fish and vascular plants. Although coverage of U and Po is slightly improved on this there are conspicuous data gaps

¹ This half-life cutoff has been selected owing to the fact that radionuclides with half-lives < 10 days have been included in the dose-conversion coefficients (DCC) of their parent radionuclides. In other words secular equilibrium with the parent is assumed and no explicit transfer or DCC for these particular radionuclides are required.

including one for aquatic birds, mammals and insect larvae. Furthermore, there are no reported data for Po in benthic fish or U in bivalve mollusc. It was evident that some of these data deficiencies could be easily mitigated with limited, but focussed effort involving field-work and analysis. Some of the key findings from the project are provided below.

^{210}Po and ^{210}Pb in freshwater and brackish water environments

Lake water and fish for ^{210}Po and ^{210}Pb analyses were sampled in 2007 from four lakes in Finland: Iso-Ahvenainen, Myllyjärvi, Vesijako and Miestämä. Five fish species were studied: perch (*Perca fluviatilis*), pike (*Esox lucius*), bream (*Abramis brama*), white fish (*Coregonus lavaretus*) and vendace (*Coregonus albula*). Lake mussel (*Anodonta* sp.) and water samples were collected from lake Keurusselkä in 2007. Additionally, fish samples from various parts of the Baltic Sea and from lakes, belonging to the monitoring programme of STUK in 2005, were analysed for Po and Pb. Furthermore, a benthic isopod (*Saduria entomon*) and a bird, swan (*Cygnus olor*), were collected from the environments of Finnish nuclear power plants in Loviisa.

Activity concentrations of ^{210}Po in whole fish varied more than ^{210}Po in lake water from the same lakes, with concentrations from 1.0 Bq/kg f.w. to 6.5 Bq/kg f.w. The lowest values for ^{210}Po and ^{210}Pb were found in pike-perch and the highest in bream. Contents of ^{210}Pb in fishes were much lower (5-15 times lower) than those of ^{210}Po , ^{210}Pb activity concentration varying from 0.09 to 1.3 Bq/kg f.w. In edible part of the fish, highest concentrations for both isotopes were measured in vendace. Activity concentration of ^{210}Po and especially that of ^{210}Pb in freshwater mussel, *Anodonta* sp., were somewhat higher than that in fishes (with an exception of bream).

Both ^{210}Po and ^{210}Pb concentrations in water from various parts of the Baltic Sea were lower than in lake waters, although values for ^{210}Po were in most cases below the detection limit, which was estimated to be 0.002 Bq/kg water. Two parallel analyses were also carried out in various parts of the swan; breast muscle, liver and bones. ^{210}Po in liver was ten times higher and ^{210}Pb six times higher than in breast muscle. Activity concentrations of ^{210}Po and ^{210}Pb in whole swan were estimated to be 1.0 and 0.4 Bq/kg f.w. In *Saduria entomon* from the Gulf of Finland, activity concentration of ^{210}Po was four times higher and ^{210}Pb almost the same than that in the freshwater mussel (*Anodonta* sp.). Among the organisms studied, the highest activity concentration of ^{210}Po was found in the crustacean *Saduria entomon*. Further information on the sample preparation, analyses methods and detailed results is provided in (Gjelsvik & Brown, 2009).

The data produced within the GAPRAD project were used to derive Concentration Ratios, i.e. activity concentration in organism divided by the activity concentration in water for the main organism categories. A comparison was thereafter made with the values underpinning the ERICA database as presented in Hosseini et al. (2008). Examples of these data are presented in Table 1. The data from this study constitute an important additional source of material to the data already collated from earlier review. It appears that some of the values in the underpinning ERICA databases may need revision following this work. For example, freshwater CRs for ^{210}Po in the GAPRAD study appear to be somewhat higher for benthic fish and somewhat lower for bivalve mollusc than those contained within the ERICA databases.

Table 1 Concentration ratios (fresh weight) for freshwater biota (whole organism) from two different studies.

Organism	CR ^{210}Po		CR ^{210}Pb	
	GAPRAD	ERICA	GAPRAD	ERICA
Benthic fish	630 - 9250	240	16 - 340	300
Bivalve mollusc	1740	38000 ± 49000	530	1400

^{210}Po and ^{210}Pb in small mammals and other fauna

Samples collected during the field work in Dovrefjell, Central Norway, were dried, pulverised and homogenised prior to gamma spectrometric analyses. Following this preliminary sample preparation and gamma analyses, small (whole body including hair) mammal samples were dried at 70°, powdered and analysed at RISØ national laboratories. All other terrestrial samples, i.e. soil, plant, lichen, earthworm and wild bird, were analysed at Lund University Hospital (Sweden). Samples were subsequently corrected for ingrowth from Pb-210.

By way of example, activity concentrations varied from 39 – 85 Bq kg⁻¹ d.w. ^{210}Po for bank vole (n = 8) and 20 – 83 Bq kg⁻¹ d.w. ^{210}Po for the common shrew (n = 9). Higher concentrations of ^{210}Po were found in bank vole compared to common shrew (Mann-Whitney U-test, Z = -2.50, p = 0.011). It appears that the primarily

herbivorous bank vole is accumulating higher concentrations of these natural radionuclides compared to the insectivorous shrew. The ^{210}Po activity concentrations for the whole body of the bank vole and shrew are similar in magnitude to activity concentrations determined for the muscle of reindeer, sampled at a site <100 km distant at Vågå in Norway. At this location activity concentrations of $36 \text{ Bq kg}^{-1} \text{ d.w.}$ in female reindeer muscle and several hundred $\text{Bq kg}^{-1} \text{ d.w.}$ in liver were determined (Skuterud et al., 2005). These activity concentrations are considerably higher than the levels reported in Beresford et al. (2007), where an activity concentration of $0.09 \text{ Bq kg}^{-1} \text{ f.w.}$ was reported for a category consigned the title “All mammals” and comprising of 32 assorted samples. Whether this discrepancy reflects the preliminary nature of the results presented in this paper, differences (physiology, diet, habitat) between the mammals considered in the aforementioned study and the present study, differences in what is being measured i.e. muscle versus whole body etc., or differences in deposition of ^{210}Pb between the study areas remains a subject for further investigation.

Polonium in man

Within the framework of GAPRAD a study was set up to establish radiobiological parameters, important in dosimetry, such as fractional uptake parameter gastrointestinal absorption factors f_1 and biological retention times of radioisotopes Po-209 and Po-210 in the body. Gastrointestinal absorption factors have been established in earlier studies with a wide range of results. For example, the International Commission on Radiological Protection has increased their reported GI factor from 10% (1979) to 50% (1993), which according to other studies seems too small.

In the first part of the study one person was given 50 mBq of ^{209}Po with an oral intake frequency of 24 hours. The goal of this part was to remain the intake frequency until constant radioactive output from urine and feces was maintained, i.e. equilibrium of intake and excretion. 24h urine samples were collected a few times every month until 320 days from the first intake. Then the intake of ^{209}Po and urine sampling stopped and 24h faeces sampling for a week was initiated. The results showed clearly a slow decreasing excretion of ^{209}Po in faeces in the range 0.59 - 0.07 % of consumed activity. Urine samples analysis showed a fluctuating value of ^{209}Po excretion with a maximum peak value of about 1 % (ca 17.5 mBq/L) 40 days from the first intake. The next step of the project was to distribute an acute oral intake to two persons of 10 Bq and then study the immediate body burden response by spectrometric analysis of urine and feces. In the acute oral intake study, the maximum daily excretion rates in faeces of 18 - 50 % can be measured three days after intake. Urine activity excretion measures an average of 0.15 - 1 % of ingested activity after two days from intake.

These results indicate a GI factor of 0.50 - 0.75, and correlates well with earlier biokinetic studies of polonium in man.

References

- Beresford, N.A., Barnett, C.L., Jones, D.G., Wood, M.D., Appleton, J.D., Breward, N., Coppstone D. (2008b). Background exposure rates of terrestrial wildlife in England and Wales. *Journal of Environmental Radioactivity*, Volume 99, Issue 9, September 2008, Pages 1430-1439.
- Brown, J. (Ed.) (2009). Knowledge gaps in relation to radionuclide levels and transfer to wild plants and animals, in the context of environmental impact assessments, and a strategy to fill them. NKS-Report NKS-182; ISBN 978-87-7893-248-8; pp. 28.
- Gjelsvik, R. & Brown, J. (Eds.) (2009). Po-210 and other radionuclides in terrestrial and freshwater environments. NKS-181; ISBN 978-87-7893-247-1, pp. 41.
- Hosseini, A., Thørring, H., Brown, J.E., Saxén, R., Ilus, E. (2008). Transfer of radionuclides in aquatic ecosystems - Default concentration ratios for aquatic biota in the Erica Tool. *Journal of Environmental Radioactivity* 99, 1408-1429.
- Larsson, C-M (2008). An overview of the ERICA Integrated Approach to the assessment and management of environmental risks from ionising contaminants. *Journal of Environmental Radioactivity*, 99 (9), pp. 1364-1370.
- Skuterud, L., Gwynn, J. P., Gaare, E. Steinnes, E. & Hove. K. (2005). ^{90}Sr , ^{210}Po and ^{210}Pb in lichen and reindeer in Norway. *Journal of Environmental Radioactivity* 84, 441-456.

The final NKS report for the NKS-B GAPRAD activity is available [here](#).

NKS-R NROI: Radiolytic oxidation of iodine in containment conditions

Joachim Holm

Chalmers University of Technology, Sweden

joachim.holm@cjalmers.se

Introduction

Iodine is a volatile and hazardous fission product that can be released during a severe accident, therefore it causes great concern in safety analyses. The behaviour of iodine during a severe accident has been studied in several experimental programs, ranging from the large-scale PHEBUS FP tests and intermediate-scale ThAI tests to smaller studies. The existing knowledge of the behaviour of iodine needs to be extended, especially in the areas of interactions of gaseous iodine with air radiolysis products in the containment atmosphere. There have been a few experimental studies of the effect of radiation on gaseous inorganic iodine chemistry, among others the early work by Vikis [1, 2]. The authors focussed on studying the reaction of I_2 with O_3 , as the resulting conversion of gaseous iodine to solid iodine oxide aerosols has the potential to allow radioactive iodine to be removed from the containment atmosphere by filtration. The reaction product was I_4O_9 at temperatures up to 100°C , but this decomposed to I_2O_5 and I_2 at higher temperatures. It is also possible that in the reaction between iodine and ozone the product is I_2O_4 [3, 4, 5, 6]. When I_2O_4 is heated up to $135\text{--}190^\circ\text{C}$ it decomposes to I_2O_5 and I_2 [7, 8].

The aim of this project was to determine the influence of oxygen, ozone and iodine concentration as well as that of radiation intensity on the possible formation of iodine oxide aerosols from elemental iodine gas. The speciation of the formed iodine particles was also considered to be investigated.

Elemental iodine oxidation experiments

The experimental set-up can be seen in the presentation of the NROI project at the NKS summary seminary (09.03.26-09.03.27). The tube line of the experimental set-up was made of stainless steel with Sulfinert® coating of the inner surfaces. The Sulfinert® coating reduces the retention of iodine to the lines and that kind of coating is widely used in many gas chromatography applications.

Gaseous iodine was produced in a separate flask at the inlet of the facility. The procedure was to add drops of H_2SO_4 from a dropping funnel into the iodine solution. A carrier gas line was connected to the flask. The flow passed through a glass needle and the produced iodine gas, $I_2(g)$, was swept out.

The gas mixture was transported to a UV furnace, which consisted of a tube of fused silica, a thermocouple for heating twirled around the silica tube and an insulating box of stainless steel. Inside the furnace, four ultraviolet lights were located with short wave length radiation (c-type). The UV light ionises the gas flow and while oxygen is within the flow it is expected to react with radiation to form ozone. An ozone generator was also used to produce ozone from air or oxygen gas. The temperature in the UV furnace was fixed at 120°C .

The gas mixture was transported to the sampling furnace, where the temperature was fixed at 120°C to prevent condensation of water inside the tubes. The tube inside the sampling furnace was divided into three main lines. One line was for analyses of the formed aerosols, which were measured with Scanning Mobility Particle Sizer (SMPS) and a CPC device. Those two devices were on-line and measured the particle size distribution and the particle concentration, respectively. Aerosol particles were also collected with a suction sampler, developed at VTT, on copper or carbon grids. The grids were analysed with Scanning Electron Microscope (SEM) and in some cases with Transmission Electron Microscope (TEM). With SEM/TEM it was possible to analyse the morphology of particles. In order to achieve information about the speciation of particles, energy dispersive X-ray (EDX) analysis was used.

The second line in the sampling furnace was used for analysing the gas phase composition, which was performed on-line with a Fourier Infrared (FTIR) device. This device was mainly used for measurements of the ozone concentration, but also for measurements of possible gas species formed due to presence of the UV radiation field. Unfortunately, FTIR is not able to measure homonuclear bimolecules (such as I_2).

Further, the third line consisted of an integral filter and three analytical sampling lines and was located downstream in the sampling furnace. The integral filter was used to filter aerosols before the gas flow was transported to a fume hood. The analytical lines consisted of one paper filter and two bubbling bottles in series. It was possible to use each analytical line separately, so data from three different conditions were received per each experiment. The liquid used in the bubbling bottles was a 0.05 M sodium hydroxide solution. After the experiments the filters were transferred directly into a bottle with 0.05 M NaOH solution,

for dissolution of the iodine aerosols. All samples, both the filter and the bubbling bottle solutions, were analysed with ICP-MS (Inductively Coupled Plasma Mass Spectroscopy).

Experimental procedure

Eight experiments were done, with three different conditions in each experiment giving 24 experiments in total. The atmosphere in the system was either air or nitrogen with oxygen. The volume fraction of oxygen in a gas flow was 50%, 21% or 2%. The experiments were conducted with dry or moist gas. The moisture in the gas flow came from the iodine production reaction. While the concentrations of oxygen, ozone, iodine and humidity were varied, it was possible to measure the effect of these parameters on the amount of reaction products.

In the experiments the total gas flow through the flow furnace ranged from 6 l/min to 24 l/min (NTP). The total flow rate was varied in order to study the effect of residence time on iodine reaction products.

Experiments were conducted with varying ozone to iodine molar fraction by changing the ozone generator production power. Also, the UVC lights were not used in every experiment and the power of the UVC radiation was varied in order to study the effect on gaseous and aerosol products.

Results

The results of the experiments are presented in Table 1. The first two columns present iodine masses collected in aerosol filters and gas bubblers. Based on this data the fraction of iodine transported as aerosol particles and as gas is calculated. Total gaseous iodine concentration fed into the system is determined by summing the filter measurements and the bubbler measurements and is presented in the table in ppm. Iodine concentration can thus be directly compared with the ozone concentration measured with the FTIR device. It should be noted though that the total iodine concentration is underestimated, because retention in the facility could not be taken into account. The last column presents the residence time of the flow inside the facility.

When aerosol and gaseous fractions of iodine are compared, it can be seen that iodine is transported either almost completely as aerosols or almost completely as gas. Some exceptions among the experiments can be seen, 2B, 2C, 4C and 7B. In these experiments ozone and iodine is present in the system, so an extensive particle formation should be expected. But complete particle formation (defined as more than 85% of the iodine in solid form), did not occur in these experiments. In the experiment 4C, the residence time was so low that the time for complete iodine condensation on the particles was too short. In experiment 7C, the incomplete particle formation probably depends on both short residence time and low ozone concentration. It is more difficult to explain the behaviour in experiments 2B and 2C, but the incomplete particle formation probably depends on problems with the particle trapping on the filters.

Nucleated aerosol particles

During the experiments it was observed that the formation of aerosol particles was almost instant, when iodine feed was on and the ozone production was started. It seemed that even low ozone concentrations were able to produce very large concentrations of particles ($\sim 10^6$ - $8/\text{cm}^3$).

Aerosol size distribution properties

According to measured aerosol number size distributions the primary particles, formed in the reaction of iodine and ozone, were very small. The diameter of the smallest particles measured was less than 10 nm. The number median diameter of particles ranged from 60 - 120 nm depending on initial iodine concentration, ozone concentration and residence time within the facility. Particle growth took place primarily by agglomeration, then the particle size increased and their number concentration decreased with increasing residence time.

The effect of initial iodine concentration on the size of the formed particles was also investigated. Increasing iodine concentration led to increasing number median diameter and decreasing number concentration of particles. This is another proof of agglomeration growth as fast nucleation rate and initially high particle number concentration would lead to much higher agglomeration growth rate. On the other hand, substantially increased size of the smallest particles with high iodine concentration also indicates particle growth by reaction of iodine on particle surfaces. This would be a secondary growth mechanism in the experiments.

Table 1: The mass and concentrations of oxygen, ozone and iodine in the experiments are presented. There is calculated residence time (t) of the flow inside the facility. UVC lights were on in seven experiments.

Exp.	O ₂ [%]	I ₂ in aerosols [mg]	I ₂ in gas [mg]	Aer. of total I ₂ [%]	Gas of total I ₂ [%]	O ₃ [ppm]	I ₂ [ppm]	t [s]	UVC
1A	50	0.004	44.0	0.01	99.99	0	93	6.8	-
1C	50	1.6	0.003	99.81	0.19	16	3.5	6.8	-
2A	50	-	-	-	-	200	NA	6.8	-
2B	50	0.005	0.006	44.08	55.92	350	0.02	6.8	-
2C	50	0.008	0.05	15.39	84.61	43	0.11	6.8	-
2D	50	0.03	0.0005	98.17	1.83	414	0.06	6.8	ON
3A	21	-	-	-	-	0.36	NA	6.8	ON
3B	21	0.006	0.04	15.09	84.91	0.34	0.09*	6.8	ON
3C	21	0.002	0.04	4.87	95.13	0.31	0.09*	6.8	ON
3D	21	0.02	0.2	11.52	88.48	0	0.45*	6.8	-
4A	21	0.4	0.001	99.65	0.35	140	0.87	6.8	-
4B	21	0.2	0.0004	99.79	0.21	130	0.36	3.4	-
4C	21	0.2	0.1	69.46	30.54	130	0.75	1.7	-
5A	21	2.6	0.0008	99.97	0.03	242	5.6	6.8	-
5B	21	2.1	0.0007	99.97	0.03	130	4.4	6.8	-
5C	21	-	-	-	-	132	NA	3.4	-
5D	21	0.03	5.8	0.50	99.50	0	12.5	6.8	-
6A	2	0.5	0.0003	99.94	0.06	110	1.2	6.8	-
6B	2	0.5	0.003	99.47	0.53	103	1.2	6.8	-
6C	2	0.4	0.005	98.82	1.18	20	0.86	6.8	-
7A	2	-	-	-	-	87	NA	6.8	-
7B	2	0.2	0.1	58.26	41.74	8.9	0.59	3.4	-
7C	2	0.1	0.001	99.25	0.75	103	0.31	3.4	-
8A	2	0.0002	0.008	2.35	97.65	0.03	0.02	6.8	ON
8B	2	0.00004	1.1	0.004	99.996	0.04	2.4	6.8	ON
8C	2	0.00007	2.3	0.003	99.997	0.04	4.9	3.4	ON

* The measurement accuracy was not good, because of the low ozone concentration.

** The column of FTIR or the volume of the facility was not completely free of ozone, even though ozone was not fed into the facility.

SEM/TEM analyses

The analysis of particles with SEM and TEM was difficult. Particles seemed to evaporate and melt when focused under the electron beam. However, it was found that particles contained iodine and oxygen. According to the literature, there are three probable iodine oxide species what to expect, I₂O₄, I₂O₅ and I₄O₉.

References

- [1] Vikis, A. C., MacFarlane, R., Reaction of iodine with ozone in the gas phase, *J. Phys Chem*, 89, 812, 1985.
- [2] Vikis, A. C., Torgerson, D. R., Gas Phase Radiation Chemistry of Iodine in Post-Accident Environments, in Proc specialists' workshop on iodine chemistry in reactor safety, Harwell, 11 September 1985, AERE-R 11974, 1986.
- [3] Burkholder, J. B., Curtius, J., Ravishankara, A. R., and Lovejoy, E. R.: Laboratory Studies of the Homogeneous Nucleation of Iodine Oxides, *Atmos. Chem. Phys.*, 3, 4943–4988, 2003.
- [4] Cox, R. A. and Coker, G. B.: Absorption cross-section and kinetics of IO in the photolysis of CH₃I in the presence of ozone, *J. Phys. Chem*, 87, 4478–4484, 1983.
- [5] Hoffmann, T., O'Dowd, C. D., and Seinfeld, J. H.: Iodine oxide homogeneous nucleation: An explanation for coastal new particle production, *Geophys. Res. Lett.*, 28(10), 1949–1952, 2001.
- [6] Jimenez, J. L., Bahreini, R., Cocker, D. R., et al.: New particle formation from photooxidation of diiodomethane (CH₂I₂), *J. Geophys. Res.-A*, 108(D10), art. no. 4318, 2003.
- [7] Daehlie, G. and Kjekshus, A.: Iodine oxides, Part I, *Acta Chem. Scand.*, 18, 144–156, 1964a.
- [8] Greenwood, N. N. and Earnshaw, A.: *Chemistry of the Elements* (2nd Edition), Butterworth- Heinemann, 1341 pp, 1997.

NKS-R ExCoolSE: The study of multiscale multiphase phenomena in Nordic BWR - Severe accidents

Pavel Kudinov, Chi-Thanh Tran, Aram Karbojian, Weimin Ma, Roberta C. Hansson and Truc-Nam Dinh

Division of Nuclear Power Safety, Royal Institute of Technology (KTH), Sweden
pavel@safety.sci.kth.se

Introduction

Swedish and Finnish boiling water reactor (BWR) plants employ cavity flooding as a severe accident management (SAM) strategy to secure containment integrity in case of reactor pressure vessel (RPV) failure and melt ejection into the cavity. It is assumed that melt will fragment and form a coolable by natural circulation porous debris bed on the containment concrete basemat. However pouring of hot melt in to a subcooled water pool introduces the risk of energetic steam explosion while debris bed coolability is contingent upon many factors and is not necessarily a settled case. The ultimate goal of the present research program at KTH is to help resolve the long-standing severe accident (SA) issues (i.e., ex-vessel steam explosion and debris coolability). The research is driven by hypotheses that (i) melt discharge from the BWR vessel is gradual, in dripping mode that largely eliminates the steam explosion risk and facilitates formation high-porosity, easy coolable debris beds, (ii) non-eutectic binary melts render low energetics steam explosions. The technical focus of the work is development of experimental and analytical methods for addressing multiscale nature of SA phenomena and reduction of epistemic uncertainty.

In-Vessel Coolability

The main sources of uncertainty for the ex-vessel stage of SA are possibility of in-vessel retention, vessel failure mode and melt characteristics upon discharge. To address the uncertainty the In-Vessel Coolability (INCO) research project was initiated at Royal Institute of Technology (KTH). The goal of the study is development of accident analysis models for prediction thermo-mechanical interactions between corium melt pool and vessel wall in different scenarios. The focus of the research is on assessment of in-vessel melt retention feasibility in case of control rod guide tube (CRGT) cooling as SAM measure. The challenge for the BWR in-vessel coolability study is accurate resolution of local heat transfer phenomena and their effect on the vessel failure mod. Direct simulation of melt pool heat transfer is rather impractical due to very complex geometry of reactor lower head with hundreds of penetrations. Therefore effective, computationally affordable models the Effective Convectivity Model (ECM), the Phase-change ECM (PECM) for internally heated volume, and metal layer ECM/PECM [1,2,3] which preserve information about local distribution of heat fluxes, and can take into account real geometry of BWR lower head, were proposed developed and validated in the framework of the INCO project. An approach to efficient use of the CFD method for development of efficient models is proposed. The validated CFD method is used to perform heat transfer simulations in specific unit-volume geometries of BWR lower plenum, to get the insights into the flow and heat transfer physics and to produce necessary data for validation of the effective models. Validation of the effective models for accident analysis is performed against existing experimental and CFD generated data. Results of validation show that predicted results are well fitted in 10% margin of experimental (and CFD-generated) data, although the further quantification of uncertainty is necessary.

The ECM, PECM, and metal layer ECM/PECM were applied to heat transfer simulation of different BWR accident scenarios in real geometry of BWR lower plenum. In the Figure 1a a melt pool in the slice segment of the BWR lower plenum is shown. It is assumed that the CRGTs are cooled by water flowing inside them. Results of simulation show that the debris bed formed in the BWR lower plenum is heated up and remelted, forming a melt pool. For the debris bed less than 0.7m deep, the CRGT cooling is capable to keep the vessel wall temperature well below the thermal creep limit, assumed to be 1100 °C (Figure 1b). However, in case of 1 m deep pool there is a region which is far from cooled CRGTs and the vessel may fail in several hours (Figure 1b).

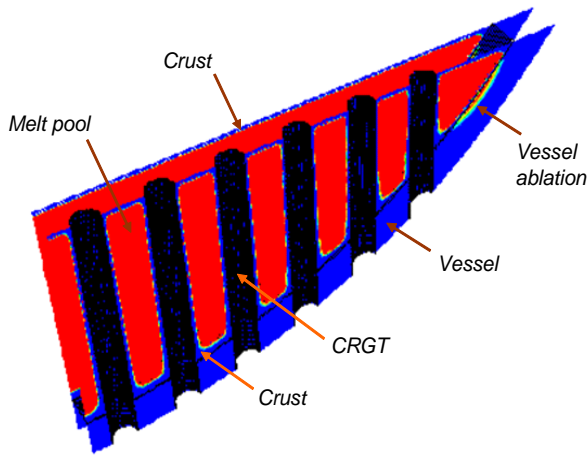

1a)

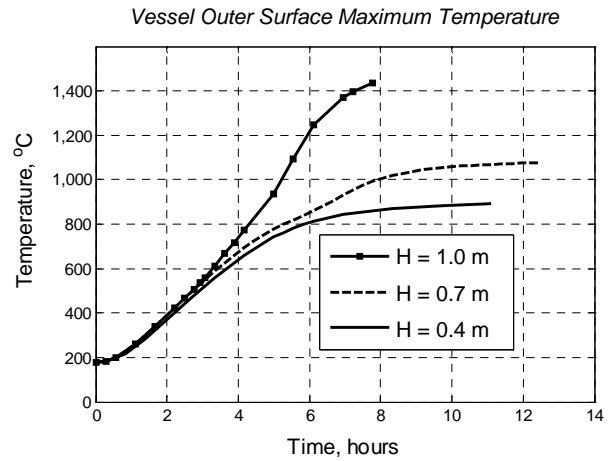

1b)

Figure 1a. Melt pool configuration in the BWR lower plenum ($t = 6.1$ h, red color-liquid; blue-solid). Figure 1b. Evolution of vessel wall maximum temperature for different melt pool depths.

Ex-vessel Coolability

The goal of the ex-vessel coolability study is reduction of epistemic uncertainty in the debris bed formation and coolability phenomena. The work has two directions correspondently: Debris Bed Formation (DEFOR) and Porous Media Coolability (POMECO). The goal of the DEFOR research program is to study mechanisms that govern debris bed formation and creation of knowledge and database needed for the assessment of coolability of debris beds formed in prototypic reactor accident scenarios. Both experimental [4] and analytical [5, 6] approaches are used in the investigation to reveal how microscopic phenomena at the scale of single particle affect macro parameters such as averaged porosity [5] and agglomeration [6].



2a)

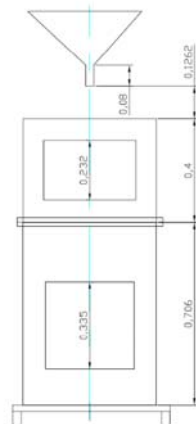

2b)

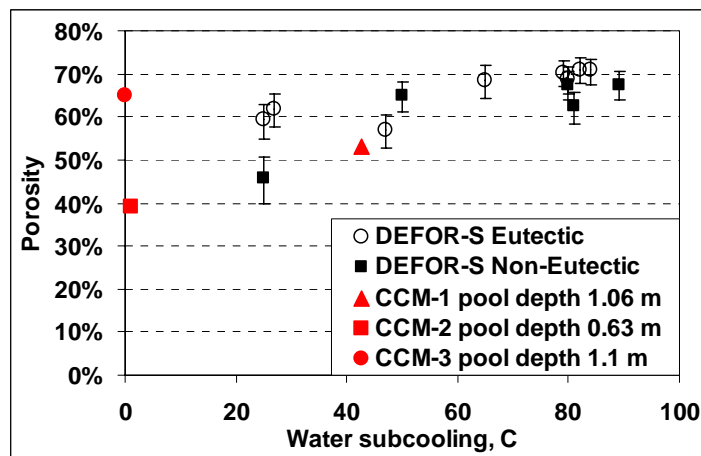

Figure 2a. DEFOR facility. Figure 2b. Dependency of the debris bed porosity on water subcooling.

The DEFOR experimental facility for performing of test on pouring of high melting temperature, binary oxidic melt simulant materials into a water pool is shown in the Figure 2a. The results of DEFOR-S experiments [4] show that porosity of a bed comprised of fragmented debris, is high (~60-70% Figure 2b), compared to the traditionally assumed value of 40%. Debris agglomeration and cake formation were also observed, contingent upon the pool's depth, water subcooling and melt superheat [4]. Size distribution and morphology of the debris fragments (including surface roughness, sharp edge, internal porosity) are brought together to show their trends as function of melt materials and water subcooling. The DEFOR-S experiments provide the first systematic database on fragment morphology and debris formation. While the bed's "macroscopic" porosity (60-70%) is potentially coolability-friendly, there remain large uncertainties in "microscopic" factors, such as the internal porosity, particle and pore size distribution, particle morphology and surface roughness, debris agglomeration. These factors may be counteractive with respect to two-phase flow permeability and passability in the bed's porous media. Understanding and characterization of both the prototypic debris bed's microscopic characteristics and their impact on corium coolability are subjects of the continued study in the DEFOR and POMECO programs with an increasing emphasis on analytical modeling and simulation.

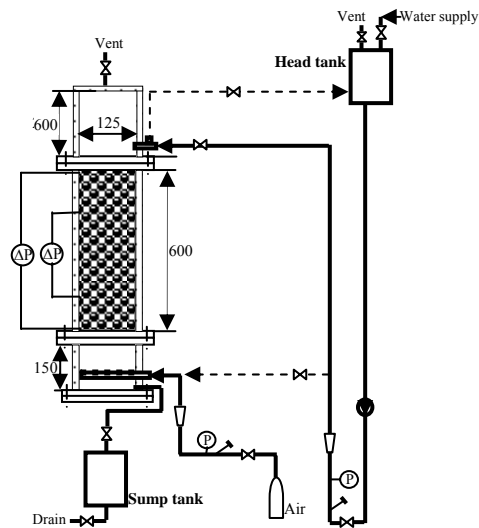

Figure 3. POMECA-FL Facility

For assessment of debris bed coolability, a semi-analytical model was developed, validated and used to investigate Natural-Circulation-Driven-Coolability (NCDC) of debris beds. Bottom-feeding, bed's inhomogeneity, and potential effect of bed characteristics found in DEFOR experiments on coolability indicated that there is substantial coolability margins, compared to the previous assessments based on models and experiments using a top-flooding, homogeneous bed with assumed porosity of approximately 40%. The heating with electric heaters embedded in a debris bed used in different experiments was predicted to reduce the dryout heat flux, in comparison with a uniformly and volumetrically heated bed.

To improve fidelity of coolability analysis, the POMECA-FL test facility (Figure 3) is designed to investigate friction laws in i) a bed packed with debris simulant (e.g., sand particles); and ii) the debris beds formed from FCI tests (e.g., DEFOR) – which have both multi-size and irregular shape particles (including, hollow particles). The POMECA-HT facility will be used to determine the dryout heat flux of debris bed packed by sand particles with the similar size distribution as in the existing FCI tests (e.g., FARO) and debris bed packed by particulate debris formed in DEFOR tests.

Steam Explosion Energetics

Molten Fuel-Coolant Interactions (MFCI) which occurs in a nuclear power plant during a hypothetical severe accident may result in energetic vapor explosions and challenge the structural integrity of the plant reactor pressure vessel and containment. In the last decades, much work has been done with the purpose of developing a better understanding on the thermo-hydraulic processes that govern the vapor explosions. More recently, in large scale corium experiments with eutectic and non-eutectic material, it was observed that the eutectic corium exploded spontaneously whereas the non-eutectic corium was shown to be resilient to an energetic interaction even when triggered. Although substantial evidences indicate an actual material effect on the resulting energetics, the relationship between the molten material type and its triggability remains unclear. On the other hand, such large scale experiments provide an integrated picture of all phases of the explosion. It is the authors' believe that the key for the understanding of vapor explosion is in the micro-interaction level, specifically, the mixing of volatile coolant into the hot melt, which is responsible for the local pressure increase that drives the escalation and propagation phases.

Dynamics of the hot liquid (melt) droplet and the volatile liquid (coolant) are investigated in the MISTEE (Micro-Interactions in Steam Explosion Experiments) facility by performing well-controlled, externally triggered, single-droplet experiments, using a high-speed visualization system with synchronized digital cinematography and continuous X-ray radiography, called SHARP (Simultaneous High-speed Acquisition of X-ray Radiography and Photography) (Figure 4) [7]. Analysis of the data obtained by the SHARP system and image processing procedure developed provide new insights into the physics of the vapor explosion phenomena, as well as, quantitative information of the associated dynamic micro-interactions [8, 9]. The acquired images followed by further analysis led to a hypothesis about a novel phenomenon called pre-conditioning, according to which dynamics of the first bubble-dynamics cycle and the ability of a triggered melt drop to deform/prefragment (Figure 4) dictate subsequent explosivity of the droplet [8]. Implications of the governing role of the melt preconditioning will be explored further on the effort to elucidate the evident effect of melt materials on vapor explosion energetics.

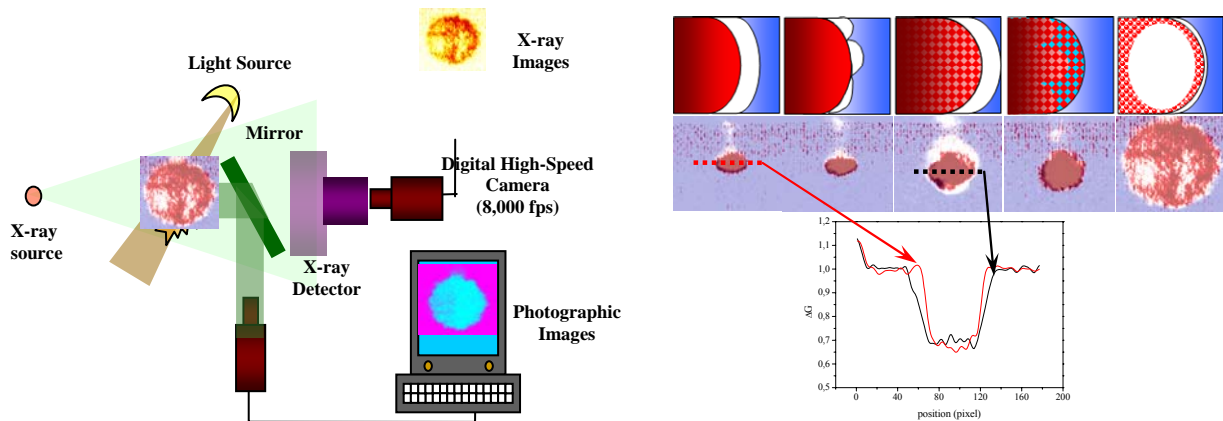

Figure 4. SHARP system and Phenomenology of droplet explosion with emphasis on the melt preconditioning.

Summary

Experimental and simulation tools developed in the framework of the research program at KTH help to reduce epistemic uncertainty in multiscale multiphase phenomena in Nordic BWR severe accidents. The future steps will be focused on application of developed and validated simulation tools to systematic study of plant scale phenomena and search for limiting physical mechanisms which can reduce the influence of aleatory uncertainty in SA scenarios.

References

- [1] C.T. Tran and T.N. Dinh, "The Effective Convectivity Model for Simulations of Melt Pool Heat Transfer in a Light Water Reactor Pressure Vessel Lower Head. Part I: Physical Processes, Modeling and Model Implementation", J. Progress in Nuclear Energy, 2009, in press.
- [2] C.T. Tran and T.N. Dinh, "The Effective Convectivity Model for Simulation of Melt Pool Heat Transfer in a Light Water Reactor Pressure Vessel Lower Head. Part II: Model Assessment and Application", J. Progress in Nuclear Energy, 2009, in press.
- [3] C.T. Tran, P. Kudinov, "The Effective Convectivity Model for Simulation of Molten Metal Layer Heat Transfer in a Boiling Water Reactor Lower Head", 2009 International Congress on Advances in Nuclear Power Plants (ICAPP'09), Shinjuku Tokyo, Japan, May 10-14, 2009.
- [4] Kudinov P., Karbojian A., Ma W., and Dinh T.-N. "The DEFOR-S Experimental Study of Debris Formation with Corium Simulant Materials," Nuclear Technology, 2009 (in press).
- [5] Kudinov P., Davydov M., "Development of Ex-Vessel Debris Agglomeration Mode Map for a LWR Severe Accident Conditions," ICONE17, July 12-16, 2009, Brussels, Belgium, Paper 75080.
- [6] Kudinov P. and Dinh T.-N., "An analytical study of mechanisms that govern debris packing in a LWR severe accident", NURETH-12, Pittsburgh, PA, USA. September 30-October 4, 2007.
- [7] Hansson, R.C., Park, H. S., Dinh, T. N., "Simultaneous High Speed Digital Cinematographic and X-ray Radiographic Imaging of an Intense Multi-Fluid Interaction with Rapid Phase Changes", Experimental Thermal and Fluid Science, Vol. 33, pp 754-756, 2009.
- [8] Hansson, R.C., Park, H. S., Dinh, T. N., "Dynamics and Preconditioning in a Single Droplet Vapor Explosion", Nuclear Technology, Vol. 167, pp 223-234, 2008.
- [9] Hansson, R. C., "Triggering and Energetics of a Single Drop Vapor Explosion: The role of Entrapped Non-Condensable Gases", Nuclear Engineering and Technology, in press, 2009.

NKS-B SPECIATION: Speciation analysis of radionuclides in the environment

Xiaolin Hou

Risø DTU National Laboratory, Denmark

xiaolin.hou@risoe.dk

Introduction

In order to assess short- and long term consequences of radioactive contamination in the environment, information on the source term including the distribution of physico-chemical forms (speciation), transformation processes occurring after release and deposition as well as the kinetics involved is needed. Such information can be obtained by means of speciation analysis of radionuclides. Determination of the total concentration of the element alone is not sufficient and may lead to erroneous conclusions. Speciation analysis is necessary for the evaluation of the risks of pollutants in the environment, the bioavailability of elements in soils or plants and the transport mechanisms of metals to the human body.

In general, the risk perspective has driven the major part of research conducted on the behaviour of natural radioisotopes as well as anthropogenic radioisotopes in the environment. This has been a natural consequence of the nuclear weapons programme and the development of nuclear power for civil use. It should however be kept in mind that for decades radioisotopes have been used for environmental tracer purposes. Radioisotopes have been used in large-scale systems such as determination of gas-exchange rates between the atmosphere and the oceans or quantification of world ocean circulation but also in microscopic events such as colloid aggregation and exchange interaction between molecules. Regardless of purpose, knowledge on the behaviour of the different radioisotopes is a key issue whether it serves to determine the possible pathways to human exposure or if it serves as a potential tracer for some process.

A NKS project entitled on “speciation analysis of radionuclides in environment (SPECIATION)” is being carried out since January 2007. This project aims at (1) overview of the research activity on speciation of radionuclides in Nordic countries, and establish a close collaboration among Nordic laboratories for speciation of radionuclides; (2) Further development and improvement of analytical methods for speciation of some important radionuclides in the environment, such as Pu, Am, Np, and ^{129}I , (3) Investigation of speciation of the some radionuclides in specific Nordic environments, such as the plutonium contamination in Thule, Greenland, issues related to Nordic repositories for nuclear waste and the behaviour in Nordic waters of radionuclides from European reprocessing facilities. (4) Intercomparison on the speciation of Pu, U, Th, ^{137}Cs , and ^{129}I in soil and sediment samples within Nordic labs. In this article, some results under this project are presented.

Further development on the method for speciation analysis of ^{129}I seawater samples

A simple method for the separation of iodide and iodate from water by co-precipitation of AgI with AgCl was developed. For separation of iodide-129, iodide carrier (1-2mg) is first added to the seawater (0.1-2 liters), and pH is adjusted to 5-7 using HCl, and then 0.2-2 ml of 1mol/L AgNO₃ is added (Cl:Ag >10 mol/mol), the solution is stirred for 30 min. and the precipitate is separated by centrifuge. 25% of NH₃ is then added to the precipitate to dissolve the AgCl, and the separated AgI is directly used for AMS analysis of iodide-129. For total I-129, after addition of iodine carrier and HCl to pH<2, NaHSO₃ solution is added to reduce iodate to iodide, then total iodine is separated by the same procedure as for iodide. The iodate-129 is calculated by the difference between iodide-129 and total iodine-129. The analytical results showed that the recovery of iodine is more than 80% and the crossover of iodate in the iodide fraction is less than 2%. Because more samples can be treated simultaneously (>10 sample /h), the method is rapid and very suitable for the in situ separation on board.

Speciation method for ^{129}I and ^{127}I in air

A method for the collection and separation of different species of iodine in air was further developed. In this method, particle associated iodine, inorganic gaseous iodine and organic gaseous iodine was collected by pumping the air through air sampler with sequential air filters as show in Fig. 1. In which the particle associated iodine was first collected on a glass fibre filter with pore size of 0.45 μm , the gas components passed through the filter. Inorganic gaseous iodine, such as I₂, HI, HIO are then trapped by cellulous filter which was impregnated in NaOH/glycerol and dried. Finally the organic gaseous iodine, mainly alkane iodide, such as CH₃I and CH₃CH₂I was trapped in a column filled with active charcoal which was impregnated with TEDA. The collected different species of iodine were then separated by a combustion method (Fig.4). In this

method, the collected sample was put into a quartz boat, and ^{125}I as yield tracer was added to the sample. The sample boat was then put in a quartz tube which was heated by a tube oven while compressed air and oxygen gas were passed through the tube during heating. The iodine released during heating up to $800\text{ }^\circ\text{C}$ was then trapped by two set of bubbler filled with 0.2 mol/l NaOH solution. One ml of tapped solution was taken for the determination of ^{127}I by ICP-MS. The remained solution was used for the separation of iodine and AMS determination of ^{129}I by solvent extraction method and AgI precipitation method as the same as for water sample.

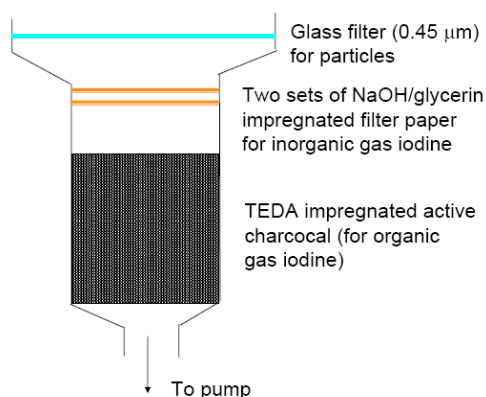

Figure 1. Air sampler for the collecting particle associated iodine, inorganic gas iodine and organic gas iodine.

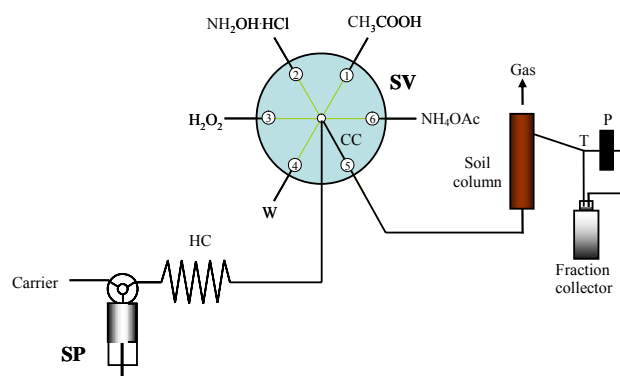

Figure 2. Schematic diagram of the dynamic sequential extraction systems.

Dynamic system for fractionation of Pu and Am in soil and sediment

A dynamic extraction system exploiting sequential injection (SI) for sequential extractions incorporating a specially designed extraction column was developed to fractionate radionuclides such as Pu, Am, Np and ^{137}Cs in environmental solid samples such as soils and sediments (Figure 2). The extraction column can contain a large amount of soil sample (up to 5 g), and under optimal operational conditions it does not give rise to creation of back pressure. The purpose of developing such a dynamic system for fractionation of radionuclides is to reduce the re-adsorption problems during sequential extraction using a modified Standards, Measurements and Testing (SM&T) scheme with 4-step sequential extractions. In addition, the dynamic system is more similar as the situation occurring in nature.

Speciation of ^{129}I in precipitation collected in Roskilde, Denmark 2001-2006

Speciation analysis of ^{129}I and ^{127}I in precipitations collected from Roskilde, Denmark in 2001 to 2006 was completed, the variation of concentrations of iodide, iodate, total iodine for ^{129}I and ^{127}I are shown in Figure 3. The concentrations of total ^{129}I in precipitation vary from 0.28 to $5.63 \times 10^9\text{ atoms L}^{-1}$ with an average of $(2.34 \pm 1.43) \times 10^9\text{ atoms L}^{-1}$, and the annual deposition flux of ^{129}I is $(1.25 \pm 0.30) \times 10^{12}\text{ atoms m}^{-2}$. Iodide is the major species of ^{129}I , which accounts for 50-99% of total ^{129}I with an average of 92%. The concentrations of total ^{127}I vary from 0.78 to 2.70 ng mL^{-1} with an average of $1.63 \pm 0.47\text{ ng mL}^{-1}$, and annual deposition of ^{127}I is $0.95 \pm 0.26\text{ mg m}^{-2}$. Unlike ^{129}I , iodate is the major species of ^{127}I , which accounts for 43-93% of total ^{127}I with an average of 68%, and the concentrations of non-ionic iodine and iodate are lower. The $^{129}\text{I}/^{127}\text{I}$ atomic values for total iodine vary from 5.04 to $76.5 \times 10^{-8}\text{ atom/atom}$ with an average of $(30.1 \pm 16.8) \times 10^{-8}$, while these values are 10 times lower for iodate with an average of $(2.95 \pm 3.13) \times 10^{-8}$. A similar seasonal variation of $^{129}\text{I}/^{127}\text{I}$ values as well as ^{129}I concentration are observed with higher values in spring and lower ones in the summer-autumn period.

^{129}I and ^{127}I and their speciation in lake sediment

In the aim of capturing both the historical changes in ^{129}I deposition since the start of the nuclear era and understand possible occurrence modes of iodine, we have measured ^{127}I and ^{129}I in a sequence of lake sediment located in central Sweden. The varve structure together with a well-defined ^{137}Cs Chernobyl peak provided constrained chronology of the sediment, which covers the period 1942-2006 (Figure 4). All samples were measured for ^{129}I and 9 selected samples were used for the sequential leaching procedure and measurement of ^{129}I and ^{127}I in four fractions of each sample.

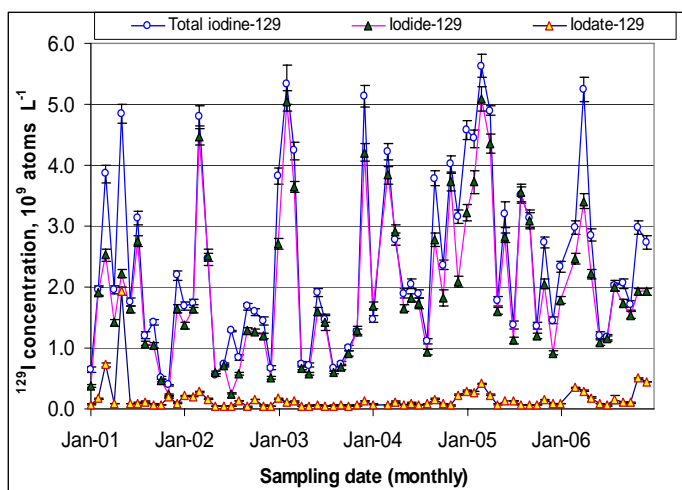

Figure 3. Variation of concentrations of ^{129}I , $^{129}\text{IO}_3^-$, and total inorganic ^{129}I in precipitation from Roskilde, Denmark in 2001-2006 (the error bar shows the analytical uncertainty).

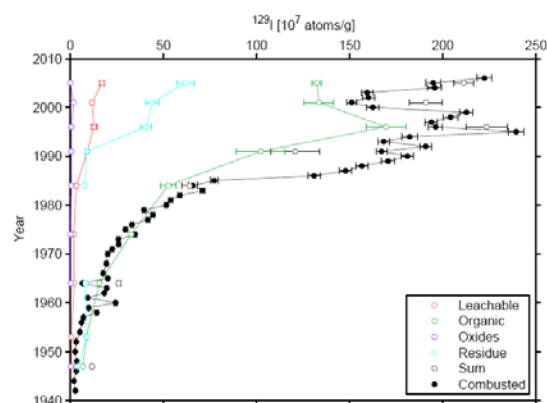

Figure 4. Depth profile of ^{129}I concentrations for total iodine and different species of ^{129}I in a lake sediment in central Sweden.

Sequential extraction of Pu in soil, sediment and concrete samples

The developed dynamic extraction method has been used to investigate the fractionation of Pu in soil collected from Thule, Greenland and heavy contamination area near Chernobyl power plant, sediment samples collected from Thule, Greenland, Palomares, Spain and Irish Sea, and concrete samples from the concrete shielding in Danish DK-2 research reactor which was decommissioned. The result (Table 1) shows that most of Pu was associated to organic and oxides fractions and small fraction of Pu exists as mobile or bioavailable form (exchangeable and carbonate) in soil and sediment. However, in the concrete sample, a large fraction of Pu exists in a mobile form (carbonate), very less associated to the organic fraction. To our best knowledge, this is the first investigation of the Pu fractionation in concrete, the results are very important with regard to waste disposal.

Table 1 Sequential fractionation of $^{239,240}\text{Pu}$ (Bq/kg) in soil, sediment, and concrete samples using dynamic sequential extraction system.

Sample	Rep.	Step 1 ^a (NH_4OAc)	Step 2 ^a (CH_3COOH)	Step 3 ^a ($\text{NH}_2\text{OH}\cdot\text{HCl}$)	Step 4 ^a (H_2O_2)	Step 5 ^a (Aqua regia)	Total ^a (1+2+3+4+5)	Total ^b (Aqua regia)
Thule Soil	1	0.37	0.26	20.5	0.76	27.9	49.8	56.5 ± 1.5
	2	0.30	0.34	17.6	0.60	35.1	53.9	
Chernobyl Soil	1	0.08	0.07	0.04	0.39	0.46	1.04	0.86 ± 0.18
	2	0.04	0.06	0.04	0.45	0.86	1.46	
Thule Sediment	1	<DL	<DL	<DL	<DL	3.71	3.71	3.90 8.60
	2	<DL	<DL	1.13	3.45	23.5	28.1	
Palomares Sediment	1	11.6	14.8	52.8	6.9	3481	3568	4006 ± 46
	2	10.1	11.8	36.5	20.4	2458	2537	
Irish Sea Sediment	1	1.49	3.02	44.6	213	46.8	309	344 ± 7.5
	2	1.90	2.26	52.0	0.90	282.4	339	
Concrete no.5	1	0.10	0.44	0.40	<DL	<DL	0.94	NA
Concrete no.6	1	<DL	0.07	0.17	<DL	<DL	0.24	0.23 ± 0.08
	2	<DL	0.05	0.11	0.16	<DL	0.32	

Conclusion and perspective

Through this project, a good collaboration was established in the Nordic labs, and a number of analytical methods were developed for the speciation analysis of radionuclides. The developed methods have been successfully used for the investigation of the environmental behaviours of radionuclides. A number of significant investigations have been completed, they are summarized below:

- 1) The speciation of Pu isotopes in radioactive concrete from the decommissioning of Danish nuclear reactor DK2 was observed to be very different with those in environmental samples such as soil and sediment, Pu in the concrete is more mobile than that in soil and sediment.
- 2) Speciation analysis of Pu isotopes in the soil and sediment from the contaminated area in Thule Greenland shows that Pu is less mobile in these samples, and therefore less bioavailable.
- 3) ^{129}I speciation was successfully applied to investigate the dispersion of pollution in the North Sea, Kattegat, and Baltic Sea, as well as for the investigation of marine geochemical cycle of stable iodine by use of the different species of ^{129}I and ^{127}I .
- 4) ^{129}I in the precipitation in Denmark dominates by iodide, while the dominant species of ^{127}I is iodate, it indicates that ^{129}I and ^{127}I have a different source.
- 5) ^{129}I is mainly associated to organic phase in the sediment and soil, which is not mobile. Speciation of radionuclides is becoming more and more attractive and important topic. However, the speciation is much more complicated when comparing to the total concentration of radionuclides.

Although much work has been done during this project, many questions remain to be answered and many applications remain to be investigated.

The final NKS report for the NKS-B SPECIATION activity is available [here](#).

NKS-B HOT II: Radioactive particles in a Nordic context

Ole Christian Lind and Brit Salbu
Norwegian University of Life Sciences, Norway
ole-christian.lind@umb.no

Introduction

Radioactive particles represent a significant fraction of the refractory (i.e. non-volatile) radionuclides released during nuclear events (Salbu, 2000). Following their release, radioactive particles represent point sources of short- and long-term radioecological significance, and the failure to recognise their presence may lead to significant errors in the short- and long-term radiological assessment of the impact of radioactive contamination at a particular site. The present work provides an overview of sources reported to have contributed to radioactive particle contamination in the Nordic environment or in areas of relevance to the Nordic countries and the characteristics of observed particles.

Fallout from more than 2300 atmospheric (Fig. 2-1), surface, underground and underwater nuclear weapon tests and sub-critical safety trials with conventional explosives are the major sources of radioactive contamination in the environment (UNSCEAR, 1993; UNSCEAR, 2000). Of these, the 543 atmospheric nuclear weapon tests are by far the most important contributor (UNSCEAR, 1993; UNSCEAR, 2000). Authorized or accidental releases from the nuclear fuel and nuclear weapon cycles, especially reprocessing plants and nuclear reactors, also contribute significantly. Releases from satellite, aircraft and submarine accidents and dumping of radioactive waste at sea have a local impact only.

Radioactive particles from nuclear tests

Nuclear weapons tests have been conducted at various locations, on ground and in underground tunnels, mounted on towers, placed on barges on the ocean surface, from balloons, dropped from airplanes, and high-altitude launchings by rockets. Depending on the location of the explosion (altitude and latitude) the radioactive debris entered the local, regional, or global environment (UNSCEAR, 1993). According to Heft (1970), all the radionuclides (except ^3H , ^{14}C and the long lived rare gases) involved in a nuclear detonation are accounted for completely as radioactive particles. In the Nordic countries, air monitoring programmes have revealed transport of radioactive particles from nuclear tests, for example from tests at Novaya Zemlya (Sisefsky, 1961) and at Lop Nor (Persson and Sisefsky, 1969). Investigations of air filters collected during 1958-1962 have demonstrated the presence of hot spots that are attributed to fallout particles (Wendel et al, unpublished)

Reprocessing and Nuclear waste sites

Siberian Nuclear sites

Nuclear weapon materials were produced at three main sites in the former Soviet Union: Mayak PA (Chelyabinsk-45 or 65), Krasnoyarsk Mining and Chemical Industrial Complex (Krasnoyarsk-26), and Siberian Chemical Combine (Tomsk-7). Relatively large routine releases occurred during the early years of operation of these facilities (UNSCEAR, 1993). In addition, accidents have contributed to radioactive contamination in the vicinity of the sites. A few reports on radioactive particle contamination in the vicinity of Tomsk-7, Krasnoyarsk-26 and Mayak exist (Bolsunovsky and Tcherkezian, 2001; Joint Norwegian-Russian expert group for investigation of radioactive contamination in the Northern areas, 2004; Sukhorukov et al., 2004; Tcherkezian et al., 1995). Although these sites are located several thousand km from the Kara Sea, remobilisation of radionuclides from particles will occur over time and the subsequent river transport into the Arctic Ocean needs to be included in impact assessments.

Dumping of nuclear waste in the Russian Arctic: Kola Bay (STUK)

In the Kola Bay, NW Russia, two types of radioactive particles have been identified in marine sediment and in lichen samples collected in the vicinity of nuclear fuel storage and radioactive waste sites (Pöllänen et al., 2001). The particles were identified by means of gamma-ray spectrometry and autoradiography, separated and subjected to various analysis techniques. ^{137}Cs was present in the sediment matrix in large ($\sim 100 \mu\text{m}$) greenish particles that were most probably pieces of paint. Although their element composition was

heterogeneous, ^{137}Cs was found to be evenly distributed. ^{60}Co in the lichen matrix was present in small ($\sim 1 \mu\text{m}$) particles. Neither U nor transuranium elements were identified in either type of particle.

Dumping of nuclear waste in the Russian Arctic: Novaya Zemlya and the Kara Sea

During 1959-1991, radioactive waste including 6 reactors with fuel, 10 reactors without fuel, vessels, barges and more than 6 000 containers were dumped in the Abrosimov, Stepovogo and Tsvolky bays and in the Kara Sea Trough (AMAP, 1997). Furthermore, the fuel assembly from the Lenin reactor, assumed dumped along the east coast of Novaya Zemlya, has not yet been localised (AMAP, 1997). In the close vicinities of dumped objects, especially containers, enhanced levels of Pu-isotopes and fission products in sediments were observed. Close to the hull of a submarine, Eu-isotopes were also identified. Based on autoradiography, heterogeneities in the sediment samples reflected the presence of particles, and strong oxidising solutions (H_2O_2 in HNO_3) were needed to leach the Pu-isotopes from the sediments. Crud particles containing ^{60}Co were also identified using SEM (Salbu et al., 1997).

No reports on the existence of radioactive particles in Niteelva sediments (repository for historical releases from Institue of Energy Technique, Kjeller, Norway) or at the spent fuel site at Andreyeva Bay appear to have been published in the open literature.

Nuclear accidents

Although most nuclear accidents have had a local impact only, some events (fires, explosions, re-entry of satellites) have resulted in global or regional contamination. When nuclear accidents occur and refractory radionuclides are released, the presence of fuel particles should be expected (Salbu, 2000). Nuclear reactors with their considerable inventories of radioactive material are potential sources of environmental contamination. Several incidents and some accidents have occurred, and radioactive particle are known to have influenced the Nordic region during two occasions; notably the fire at Windscale piles (Salbu et al., 1994) as well as the explosion and subsequent fire at Chernobyl (Victorova and Garger, 1990).

One of the fuel channels of the RBMK reactor Unit 3 in Sosnovyy Bor, near St. Petersburg, Russia, broke down on 23-24 March 1992. Small amounts of noble gases, iodine and particulate radioactive materials were released and transported towards Finland (Toivonen et al., 1992) and radioactive particles were subsequently identified in air filter? samples (Paatero and Hatakka, 1997; Pöllänen, 1997).

Since the beginning of the nuclear age there have been numerous accidents involving nuclear weapons. In January 1968 a B52 plane from the US strategic Air Command caught fire and crashed on the sea ice in Bylot Sound about 12 km west of the Thule Air Base, Northwest Greenland. Fissile material, i.e. U and Pu, from four weapons was dispersed over ice in a distance of a few kilometres, mainly as hot particles. It has been estimated that the inventory of $^{239+240}\text{Pu}$ is somewhere between 1 and 10 TBq (Eriksson, 2002), i.e. significantly higher than estimated prior to mid 1990s. The particles contain significant amounts of enriched U in addition to Pu and these elements coexist throughout the particles (Eriksson et al., 2005) as a mixture of oxides of U and Pu, although not homogeneously mixed (Lind et al., 2007).

Technologically Enhanced Naturally Occurring Radioactive Material (TENORM)

Radioactive particles are not exclusively of anthropogenic origin. For example, small grains of Th-bearing and U-bearing minerals, which occur naturally in soil and sediments, may also be considered as radioactive particles (Entwistle et al., 2003). Moreover, Th, U and daughter nuclides such as $^{210}\text{Po}/^{210}\text{Pb}$ (Landa et al., 1994) may be heterogeneously distributed in minerals, thus occurring as hot spots in U mining and tailing sites. Recently, single grains of U minerals have been isolated from soil samples originating from former U mining sites in Kazakhstan and Kyrgyzstan (Lind et al., 2008). Apparently, no reports on radioactive TENORM particles identified in the Nordic countries are to be found in the open literature, However, in ESEM-XRMA, heterogeneities (i.e. U hot spots) have been observed on surfaces of Norwegian mineral specimens (Salbu et al., unpublished).

Conclusion

The present overview report shows that there are many existing and potential sources of radioactive particle contamination of relevance to the Nordic countries. Following their release, radioactive particles represent point sources of short- and long-term radioecological significance. The failure to recognise their presence may

lead to significant underestimation of the inventory (partial leaching prior to analysis) and errors in the short- and long-term impact assessments related to ecosystems affected by particle contamination. Thus, there is a need of knowledge with respect to the probability, quantity and impact of radioactive particle formation and release in case of specified potential nuclear events (e.g. reactor accident or nuclear terrorism). Furthermore, knowledge with respect to the particle characteristics influencing transport, ecosystem transfer and biological effects is important. In this respect, it should be noted that an IAEA coordinated research project (CRP) was running from 2000-2006 (IAEA CRP, 2001) focussing on characterisation and environmental impact of radioactive particles, while a new IAEA CRP focussing on the biological effects of radioactive particles is under planning.

References

- Entwistle, J.A., Flowers, A.G., Nageldinger, G., Greenwood, J.C., 2003. Identification and characterization of radioactive 'hot' particles in Chernobyl fallout-contaminated soils: the application of two novel approaches. *Mineralogical Magazine* 67, 183-204.
- Eriksson, M., Osan, J., Jernstrom, J., Wegrzynek, D., Simon, R., Chinea-Cano, E., Markowicz, A., Bamford, S., Tamborini, G., Torok, S., Falkenberg, G., Alsecz, A., Dahlgaard, H., Wobrauschek, P., Strel, C., Zoeger, N., Betti, M., 2005. Source term identification of environmental radioactive Pu/U particles by their characterization with non-destructive spectrochemical analytical techniques. *Spectrochim. Acta B* 60, 455-469.
- Eriksson, M., 2002. On weapons plutonium in the Arctic environment (Thule, Greenland), in: *Risø National Laboratory*, pp. 1-146.
- Heft, R.E., 1970. Characterization of Radioactive Particles from Nuclear Weapons Tests 28. *Advances in Chemistry Series*, 254-&.
- IAEA CRP, 2001. Radiochemical, Chemical and Physical Characterisation of radioactive particles in the environment, in: *First RCM report ed. IAEA, Vienna*.
- Landa, E.R., Stieff, L.R., Germani, M.S., Tanner, A.B., Evans, J.R., 1994. Intense Alpha-Particle Emitting Crystallites in Uranium Mill Wastes. *Nuclear Geophysics* 8, 443-454.
- Lind, O.C., Salbu, B., Janssens, K., Proost, K., Garcia-Leon, M., Garcia-Tenorio, R., 2007. Characterization of U/Pu particles originating from the nuclear weapon accidents at Palomares, Spain, 1966 and Thule, Greenland, 1968. *Sci. Total Environ.* 376, 294-305.
- Lind, O.C., Strømman, G., Skipperud, L., Rosseland, B.O., Janssens, K., De Nolf, W., Jaroszewicz, J., Burkitbayev, M., Salbu, B., 2008. Speciation and source identification of U from contaminated TENORM sites, in: 10 ed. *European Geological Union, Vienna*.
- Paatero, J., Hatakka, J., 1997. Measurements of long-lived radioactivity in the air and precipitation in Finland 1991-1994, in: *Finnish Meteorological Institute, Helsinki*.
- Persson, G., Sisefsky, J., 1969. Debris from Sixth Chinese Nuclear Test. *Nature* 223, 173-&.
- Pöllänen, R., 1997. Nuclear fuel particles and radiological hazard, in: *University of Helsinki*.
- Salbu, B., 2000. Source-related characteristics of radioactive particles: A review. *Radiat. Prot. Dosim.* 92, 49-54.
- Salbu, B., Krekling, T., Oughton, D.H., Ostby, G., Kashparov, V.A., Brand, T.L., Day, J.P., 1994. Hot Particles in Accidental Releases from Chernobyl and Windscale Nuclear Installations. *Analyst* 119, 125-130.
- Sisefsky, J., 1961. Debris from Tests of Nuclear Weapons - Activities Roughly Proportional to Volume Are Found in Particles Examined by Autoradiography and Microscopy. *Science* 133, 735-&.
- Toivonen, H., Pollanen, R., Leppanen, A., Klemola, S., Lahtinen, J., Servomaa, K., Savolainen, A.L., Valkama, I., 1992. A Nuclear Incident at A Power-Plant in Sosnovyy-Bor, Russia. *Health Phys.* 63, 571-573.
- UNSCEAR, 1993. Sources and effects of ionizing radiation, in: *United Nations, New York*, pp. 1-922.
- UNSCEAR, 2000. Sources and effects of ionizing radiation, in: *United Nations, New York*, p. 1.
- Victorova, N.V., Garger, E.K., 1990. Biological monitoring of the deposition and transport of radioactive aerosol particles in the Chernobyl NEP zone of influence, in: *Proceedings of the CEC seminar on comparative assessment of the environmental impact of radionuclides released during three major nuclear accidents; Kyshtym, Windscale, Chernobyl, EUR 13574 ed*, pp. 223-236.

The final NKS report for the NKS-B HOT II activity is available [here](#).

NKS-R WERISK: Climate extremes in changing climate

Grigory Nikulin¹, Erik Kjellström¹, Lars Bärring¹, Ari Venäläinen², Seppo Saku² and Kirsti Jylhä²

¹Rosby Centre, Swedish Meteorological and Hydrological Institute, Sweden.

²Finnish Meteorological Institute, Finland.

grigory.nikulin@smhi.se

Introduction

Future climate scenarios show not only possible changes in the mean state but also changes in weather extremes. Together with a pronounced warming over Europe there is a tendency that weather extremes may become more intense and/or more frequent in the future (Beniston et al., 2005). Intensified extreme weather events may prevent normal power operation and simultaneously endanger safe shutdown of nuclear power plants. Extreme weather events could influence, for example, the external power grid connection, emergency diesel generators (blockage of air intakes), ventilation and cooling of electric and electronics equipment rooms and the cooling water intake. In the joint project Climate risks and nuclear power plants (WERISK) the Finnish Meteorological Institute and the Swedish Meteorological and Hydrological Institute investigate changes in temperature extremes, both as observed for the 20th century and as simulated by climate models for the 21st century. Here we present changes, simulated by a regional climate model, in annual maximum and minimum temperature extremes over Scandinavia for the 21st century.

Data and method

For downscaling of Global Climate Model (GCM) scenarios over Scandinavia we use the Rosby Center Regional Climate Model (RCA3) (Kjellström et al., 2005) with a horizontal resolution of 0.44° (approximately 50 km). The RCA3 is driven by boundary conditions from three simulations with the ECHAM5/MPI-OM global model (Roeckner et al., 2006). All three use the same A1B emission scenario (Nakićenović et al., 2000) but the different initial conditions in 1860. There are two reasons for utilising several ensemble members; i) an ensemble samples a part of the natural variability in the climate and ii) the number of data increases significantly.

The estimated probabilities of annual maximum or minimum temperature at the 2 meter level are expressed in terms of 50-year return values. The 50-year return value is defined as the threshold that is exceeded once every 50 years. Or, in other words, the threshold that is exceeded any given year with the probability 1/50. In order to take into account the possible non-stationary nature of extremes in transient simulations we use a moving window approach. The parameters of the generalized extreme value (GEV) distribution are estimated by applying the 21-year moving window and pooling three members of the ECHAM5-driven ensemble into one sample gives the total sample size 63 for each 21-year window. The 50-year return values are then estimated by inverting the GEV cumulative distribution function.

Results

The simulated 50-year return levels of annual maximum and minimum temperature for the reference 1970-1990 period are presented in Figs. 1a and 2a. We should note that for this period the model substantially underestimates maximum temperature and overestimates minimum temperature with a bias 5-8°C (not shown). The bias is mainly due to inadequacies in cloud water and radiation fluxes in the model (Kjellström et al., 2005). The simulated changes in maximum temperature extremes show the largest increase in the 50-year return level over southern Sweden and south-western Finland. By the end of this century the increase is 3-6 °C (Fig. 1f). Closer in time, as for the 2010-2030 period (Fig. 1c), the increase in the 50-year return level of maximum annual temperature is in most of Sweden and in southern Finland 0-2 °C.

In case of minimum temperatures the spatial distribution is different (Fig. 2). As the simulated warming is larger in the north also the largest change in the 50-year return levels of daily minimum temperature can be found in parts of northern Sweden and Finland by the end of this century (Fig. 2f). The change may exceed 10 degrees. This means that very cold temperatures would become much more rare in Lapland. Also in other areas the change in the annual lowest temperatures is predicted to be larger than in the case of annual highest temperatures. These results are consistent with previously reported results for means and extremes in this area (Kjellström et al., 2007).

50-year return values of annual maximum 2m temperature

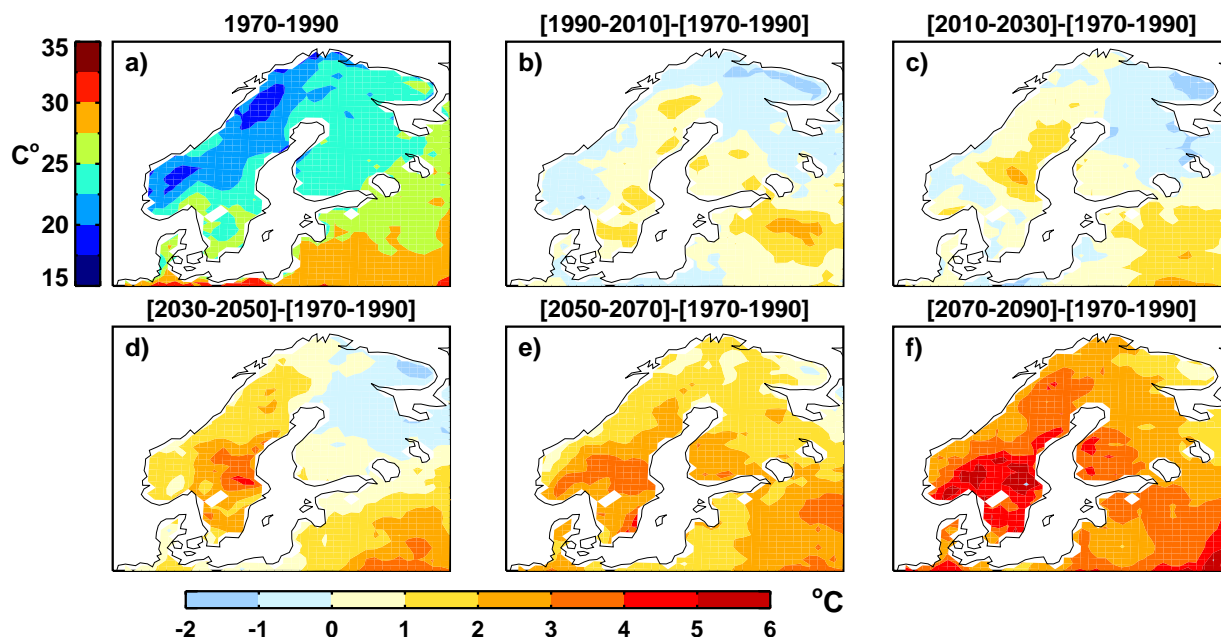

Figure 1. a) The simulated 50-year return level of annual maximum temperature at the 2-meter level for the 1970-1990 period and its A1B scenario change for five subsequent periods: b) 1990-2010, c) 2010-2030, d) 2030-2050, e) 2050-2070 and f) 2070-2090.

50-year return values of annual minimum 2m temperature

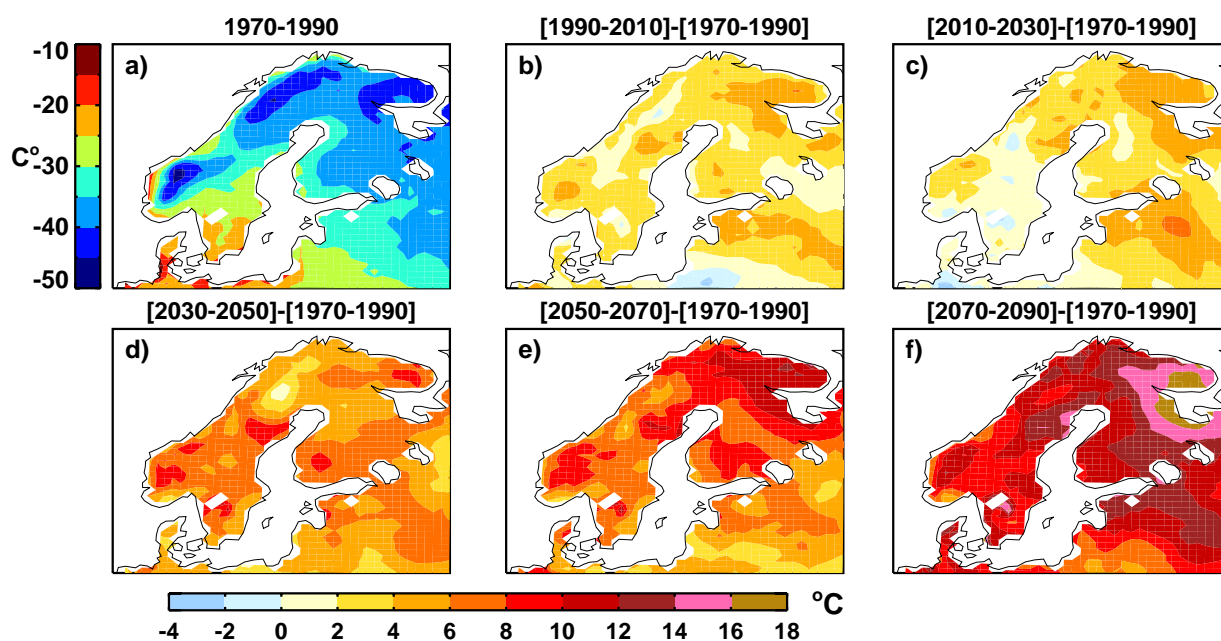

Figure 2, The same as Fig. 1 but for annual minimum temperature

Finally we note that the presented results for future extremes are based on just a few simulations with climate models. We are aware that such a small set of experiments only sample a small part of the uncertainty related to climate change. In particular, the three ensemble members do sample some of the uncertainties related to natural variability. A larger ensemble that also sample uncertainties related to emissions (different emission scenarios) and choice of boundary conditions (different GCMs) would be preferable. Some results of that kind have been obtained within the European PRUDENCE and ENSEMBLES projects (e.g. Beniston et al., 2007). Also, other RCMs should be used in such a context as much of the uncertainties in the extremes and higher order variability is related to the choice of RCMs (Kjellström et al., 2007).

References

- Beniston, M., Stephenson, D., Christensen, O., Ferro, C., Frei, C., Goyette, S., Halsnaes, K., Holt, T., Jyllhä, K., Koffi, B., Palutikof, J., Schöll, R., Semmler, T., and Woth, K.: 2005, 'Current and future extreme climatic events in Europe: observation and modeling studies conducted within the EU "PRUDENCE" project'. *Clim. Change*, Vol 81, Suppl. 1, 71-95.
- Kjellström, E., Bärring, L., Gollvik, S., Hansson, U., Jones, C., Samuelsson, P., Rummukainen, M., Ullerstig, A., Willén U. and Wyser, K., 2005. A 140-year simulation of European climate with the new version of the Rossby Centre regional atmospheric climate model (RCA3). *Reports Meteorology and Climatology 108*, SMHI, SE-60176 Norrköping, Sweden, 54 pp.
- Kjellström, E., Bärring, L., Jacob, D., Jones, R., Lenderink, G and Schär, C., 2007. Modelling daily temperature extremes: Recent climate and future changes over Europe. *Climatic Change*. 81, 249-265. doi:10007/s10584-006-9220-5
- Nakićenović, N., Alcamo, J., Davis, G., de Vries, B., Fenhann, J., Gaffin, S., Gregory, K., Grübler, A., et al., 2000. *Emission scenarios*. A Special Report of Working Group III of the Intergovernmental Panel on Climate Change. Cambridge University Press, 599 pp.
- Roeckner, E., Brokopf, R., Esch, M., Giorgetta, M., Hagemann, S., Kornblueh, L., Manzini, E., Schlese, U. and Schulzweida, U., 2006. Sensitivity of simulated climate to horizontal and vertical resolution in the ECHAM5 atmosphere model, *Journal of Climate*, 19, 3771-3791.

The final NKS report for the NKS-R WERISK activity is available [here](#).

NKS-R PODRIS: Importance of inspection reliability assumptions on piping failure probability estimates

Kaisa Simola¹, Otso Cronvall¹, Ilkka Männistö¹, Jens Gunnars², Peter Dillström², Lars Alverlind² and Luca Gandossi³
¹VTT, Finland
²Inspecta, Sweden
³European Commission Joint Research Centre
kaisa.Simola@vtt.fi

Introduction and background

Leakages and ruptures of piping components lead to reduction of loss of the pressure retaining capability of the system, and contribute to the risk of nuclear power plants. In-service inspections (ISI) aim at verifying that defects are not present in components of pressure boundaries or, if there are defects, ensuring that these are detected before they affect the safe operation of the plant.

Reliability estimates of piping (and other structural components) are needed e.g. in PSA studies, risk-informed ISI applications, and other structural reliability assessments. The reliability of piping components is affected by ISI, since inspection results increase the knowledge of the state of the inspected components.

Risk-informed in-service inspections (ISI) aim at optimising the inspection programme by taking into account the plant risk analysis results and directing inspections to the risk-significant locations. This will result in a better allocation of resources, in proportion to their importance for safety. Finland and Sweden are leading European countries in using extensively risk-informed methodologies, and the applications risk-informed ISI approaches are very topical in both countries.

When moving from a deterministic ISI programme to a risk-informed ISI, the impact of the ISI programme changes on risk is evaluated. One important contributor in the risk evaluation is the inspection reliability, since the risk reduction through inspection is directly related to the inspection reliability. The quantification of the risk impact calls for the use of quantitative measures for failure consequences and probabilities.

One approach to quantify the piping failure probabilities is the use of probabilistic fracture mechanics (PFM) models. These models can account for the ISI effectiveness and interval, and allow sensitivity studies. A detailed modelling of ISI effectiveness is difficult, since it depends on several factors, and it would be very expensive to produce statistical data to estimate the probability of detection (POD) for various flaws. On the other hand, one could question the need of very detailed POD estimates in RI-ISI applications. If sufficient risk reduction can be shown by using simplified (conservative) POD estimates, more complex PODs are not needed.

Objectives of the study and expected results

The purpose of the study is to investigate reasonable and practical requirements that should be set for assumptions about the accuracy of how inspection reliability is quantified in terms of probability of detection (POD) curves, especially from a RI-ISI point of view. Another objective of the study is to benchmark Nordic approaches to quantify piping failure probabilities with probabilistic fracture mechanics (PFM) approaches.

The project consists of following phases:

- 1) Definition of a set of cases to be analysed
 - The cases should represent piping welds under varying loading and environmental conditions, and susceptible for various degradation mechanisms. Further a set of probability of detection (POD) functions will be defined.
- 2) Analyses of selected cases
 - Application of probabilistic fracture mechanics methods and tools to analyse selected piping weld cases with various POD assumptions
 - Sensitivity studies
- 3) Comparison of results

- Evaluation of the impact of various assumptions on the results, conclusions on the benchmarking of the PFM tools and on the effect of POD assumptions on risk reduction
- 4) Reporting in a NKS report

The results can be utilised in application and evaluation of quantitative RI-ISI analyses, and the benchmarking can provide added confidence on the modelling approaches. The results of the POD analyses may justify the use of rather simple POD curve assumptions in RI-ISI. Such simplified POD curves would be much easier to derive and justify e.g. from the inspection qualification process than more complex functions. The study can also help to clarify what level of POD needs to be proven at qualification of an inspection procedure. In some cases the results might justify relaxation of the required inspection capability and qualification.

Status of the project

Three cases have been selected to be analysed, and input data for probabilistic fracture mechanics calculations have been defined. Table 1 shows the piping system and dimensions of the analysed piping welds.

Table 1. Analysed cases

Case identifier	System	Pipe diameter (mm)	Wall thickness (mm)
BWR1	Recirculation piping system	114	8
BWR2	Shutdown cooling system	324	25
PWR3	Primary loop	872	65

Following input parameters have been collected and agreed upon among the project group:

- Pipe and defect geometries: pipe dimensions, defect depth and length distributions
- Loadings: internal pressure and temperature, membrane stress, primary and secondary global bending loads, residual stresses, design limiting stress
- Material data: yield stress, ultimate tensile stress, fracture toughness, crack growth law parameters, Young's modulus, Poisson's ratio

For each of the analysed welds, three POD functions were determined. The most detailed POF function was taken from SKI report 3/2005 [1]. This is referred in the following as "full POD". Two simplified, conservative step functions were based on following assumptions:

- 1) Detection limit 2 mm, i.e. flaws below 2 mm are not detected. Probability of detection for flaws above 2 mm is constant, corresponding to the detection probability of 2 mm flaws of the "full POD" (=0.65).
- 2) Detection limit 80% of the wall thickness, smaller flaws are not detected. Probability of detection for flaws above 80% of the wall thickness is constant, corresponding to the detection probability determined by "full POD" at 80% of wall thickness.

The background for the step functions is following: 2 mm is a typical detection limit requirement for the NDE system. The value 80% of wall thickness is a maximum allowable crack size. Figure 1 illustrates the POD functions used in Case PWR3.

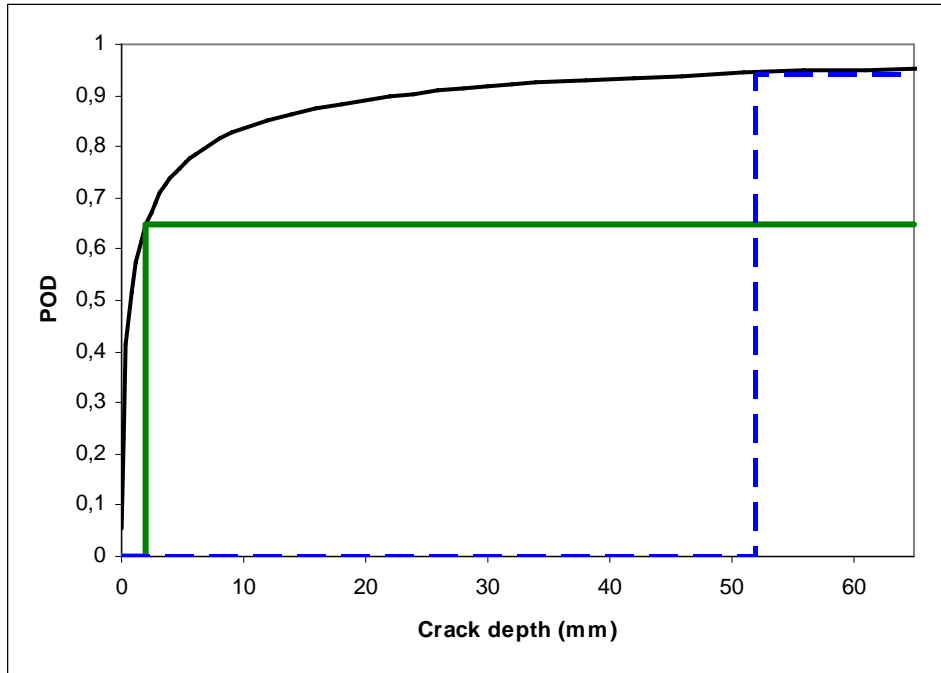

Figure 1. POD functions for Case PWR3. Black solid line is the “full POD” according to [1], green solid line is the Step1 POD (detection limit 2 mm) and the blue dashed line is the Step2 POD (detection limit 80% of wall thickness).

For each POD case, it was assumed that the inspections take place at 6 years intervals. In addition to analysing the crack growth under these POD assumptions, calculations were also run assuming that the welds are not inspected. All calculations were run for 60 year plant lifetime.

Some preliminary calculations have been performed by Inspecta and VTT. The analyses need still to be verified, and thus the results presented here may not be final.

In table 2 we show the risk reductions due to inspections for the three different POD assumptions for Case PWR3. The percentages indicate how many percent the cumulative failure probability at the end of the lifetime is decreased due to the inspections. Note that this accumulates the effect of all inspections (totally 10 inspections in 60 years).

Table 2.

	Analysis tool 1	Analysis tool 2
“full POD”	99%	99.9%
Step1 POD (step at 2 mm)	94%	98%
Step2 POD (step at 0,8t)	25%	17%

It is clear that highest risk reduction is obtained with the “full POD” assumption. The Step1 POD results also in a very high risk reduction, although the POD level is only 0,65. In the case of the Step2 POD, achieved risk reduction is small. This indicates that if a crack has grown close to the maximum allowable crack size, it is likely that it can grow through the wall in shorter time than the inspection cycle, and thus is not captured by an inspection.

The results depend on the growth characteristics of a flaw, which in turn depends on the material properties, loadings and other environmental conditions.

The project is going on, and further analyses and sensitivity studies will be run and reported in the final report.

References

1. Jelinek, T., Tidström, L. & Brickstad, B. Probability of Detection for the Ultrasonic Technique According to the UT-01 Procedure. SKI report 3/2005.

NKS-B NordRisk: Nuclear risk from atmospheric dispersion in Northern Europe

Bent Lauritzen

Risø DTU National Laboratory, Denmark

blau@risoe.dtu.dk

Introduction

The objective of the NordRisk (2005-6) and NordRisk II (2008-9) projects has been to find practical means for assessing the risks due to long-range atmospheric dispersion of radioactive materials. Within the first of these projects two different assessment tools were developed: 1) an atlas over different atmospheric dispersion and deposition scenarios based on numerical weather prediction model data, and 2) a PC-based software tool providing an analytical model for the climatological mean dispersion and deposition of radionuclides. While the atlas provides a simplified risk assessment tool using historical data, the software allows the user to alter parameter values describing the release and meteorology and can therefore be used for assessment of the risks from e.g. other release sites, accident scenarios, and meteorological conditions.

The NordRisk II project will further develop these tools taking into account the detailed topography and climatology relevant to the Nordic region. The atlas will be extended to cover more release sites in and near the Nordic countries. A thorough statistical analysis of the long-range dispersion and deposition patterns will be performed aiming at quantifying both the mean dispersion and deposition and the variability associated with long-range atmospheric transport and deposition. Hence, the expected outcome of NordRisk II will be a simplified probabilistic risk assessment (PRA) tool in which the (default) parameters needed to describe the probability density functions are derived from the statistical analysis of the atmospheric dispersion model data.

The potential end-users are foremost the Nordic emergency management authorities; the authorities participate in the project along with Nordic research institutions (Table 1). The two assessment tools developed through the project are primarily intended for emergency preparedness planning purposes, but even for ongoing accidents the tools may be used for rapid assessment of the scale of the radioactive contamination. Hence, the atlas and the software tool are intended to be used as a supplement to decision support systems currently applied in Nordic nuclear emergency preparedness. In NordRisk II the underlying data will be made available in a format which is compatible with the ARGOS decision support system.

Table 1. NordRisk projects participants

NordRisk and NordRisk II	Risø DTU National Laboratory Denmark Danish Meteorological Institute (DMI) Norwegian Radiation Protection Authority (NRPA) Swedish Radiation Protection Authority (SSI)
NordRisk II	Danish Emergency Management Agency Geislavarnir Ríkisins

The Risk Atlas

Probabilistic Risk Assessment for atmospheric dispersion addresses the possible transport and deposition of radioactive material released from a given risk site. Such assessments may readily be carried out for short-range atmospheric dispersion from a nuclear installation using numerical weather prediction model data coupled to a local atmospheric dispersion and deposition model. Even for long-range atmospheric transport on a European scale, such calculations have been made possible in recent years with the increase in computing power. In the NordRisk projects calculations are carried out with the purpose of developing an atlas of long-range atmospheric dispersion scenarios. The atlas is based on archived numerical weather prediction (NWP) model data coupled to the Danish atmospheric dispersion model DERMA and contains case studies of hypothetical releases from nuclear installations in the Northern Hemisphere (ERA-40, Sørensen et al., 2007).

The results of these long-term, long-range atmospheric transport and deposition calculations are presented in a risk atlas as a series of maps showing time-integrated air concentration and total deposition fields (Fig. 1). The atlas applies both to accidental (short-term) releases of radionuclides and to continuous emission of radionuclides or other contaminants from a given risk site. In both cases, the atlas maps the “ensemble mean” concentration fields. For accidental releases, combined with a release risk assessment or an indication of the magnitude of the actual release the maps provide a first assessment of the mean-value of the radioactive

contamination. For continuous emissions of radionuclides or other contaminants from a risk site, the atlas directly provides the expected geographical scale of contamination.

Both for the short-term and the long-term release conditions, large fluctuations due to the stochastic nature of atmospheric transport and deposition are to be expected compared to the ensemble mean-values. The dispersion model calculations, in addition to the mean concentration fields, provides information on the variability both in the case of a continuous release and based on (accidental) short-term releases (Fig. 2). In combination with the ensemble-mean value, the assessed variability constitutes a probabilistic risk assessment of atmospheric transport of radionuclides under similar meteorological conditions as used for the atlas.

The atlas describes different release sites and radionuclides. A general trend for the long-term averaged deposition or air concentration fields is the tendency towards pattern of a near-isotropic ensemble-mean deposition. Fluctuations around the mean value are in most cases well described by a gamma model distribution.

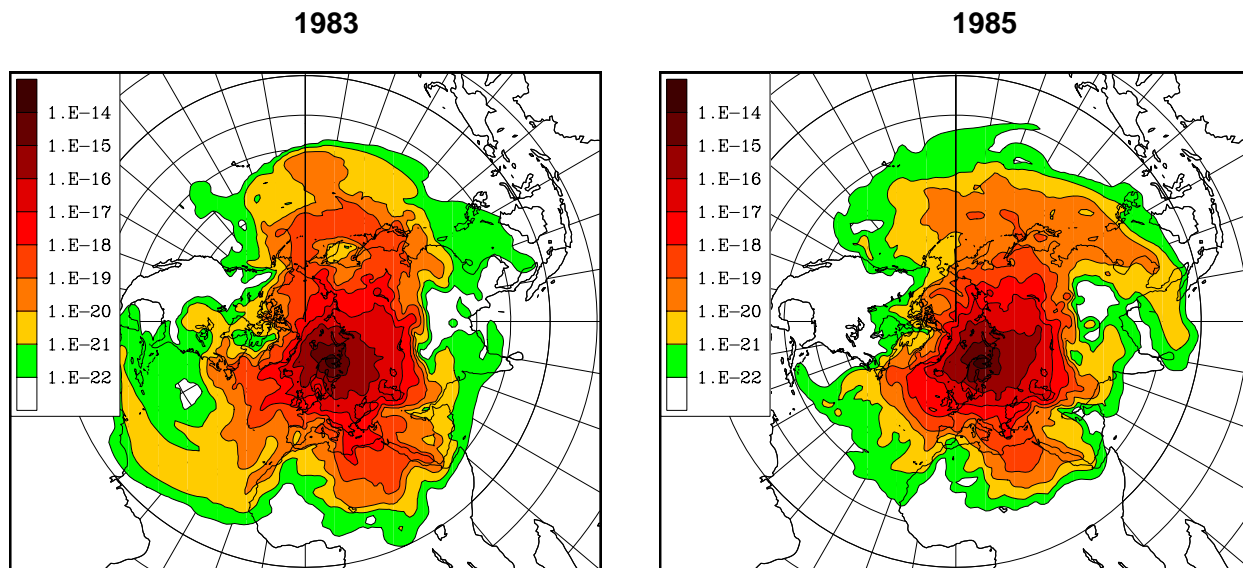

Figure 1. Deposition of ^{137}Cs from two one-year continuous release from Kola NPP.

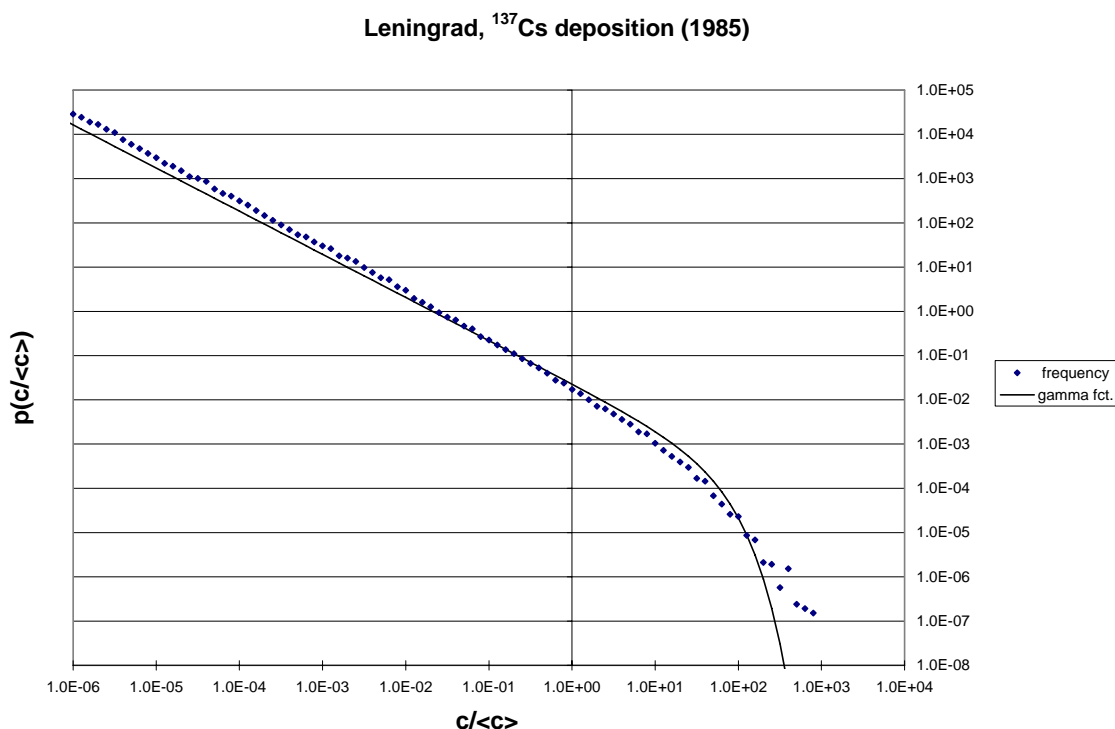

Figure 2. Probability density function of the relative deposition density, based on 24-hour releases. The solid line is a gamma model distribution with shape parameter $1/\phi = 0.025$.

Risk Assessment

The software tool developed in the NordRisk project is based on a simple model for the *ensemble mean* deposition fields. The basic assumption is here that the *ensemble mean* long-range atmospheric dispersion and deposition can be modelled as a pure advection-diffusion process with constant diffusivity and deposition parameters (Lauritzen and Mikkelsen, 1999). The model can be solved analytically and its resulting fields coded for graphical presentation. While the model does not account for the complexity associated with real-time dispersion model calculations, the simplified model does provide a fairly good approximation to the gross deposition patterns associated with the ensemble-mean dispersion and deposition (Lauritzen et al., 2006).

The model contains only a small number of parameters, which depend both on the meteorological conditions and on the physical-chemical properties of the dispersed material. The parameter values must be set externally, either from model assumptions, e.g. from regression against numerical dispersion model calculations such as those employed for the NordRisk atlas, or from expert judgments.

In the context of nuclear emergency management the analytical model is only useful to the extent that suitable parameters for an accident situation can readily be found. A main objective of the NordRisk II project is therefore both to perform comprehensive numerical calculations of long-term, long-range atmospheric dispersion and deposition specific to the Nordic region and to perform a thorough statistical analysis of the resulting deposition patterns. The aim of the statistical analysis is to identify the general trends of the ensemble mean and the variability of long-range atmospheric transport and to derive default parameters describing the resulting deposition and air concentration fields.

When coupled with assumed release profiles of radioactive material from North European sites this will constitute a probabilistic risk assessment tool based on historical NWP model data. With default parameters for the long-range atmospheric transport of radionuclides the simplified model will allow for a rapid assessment of risks from sites and for accident release scenarios for which detailed, long-term numerical atmospheric dispersion model calculations have not already been carried out.

References

ERA-40. <http://www.ecmwf.int/products/data/archive/descriptions/e4>

Lauritzen, B. and T. Mikkelsen. A probabilistic dispersion model applied to the long-range transport of radionuclides from the Chernobyl accident. *Atmos. Environ.* **33** (1999) 3271-3279.

Lauritzen, B., A. Baklanov, A. Mahura, T. Mikkelsen and J. H. Sørensen. K-model description of probabilistic long-range atmospheric transport in the Northern Hemisphere. *Atmos. Environ.* **40** (2006) 4352-4369

Sørensen, J. H., A. Baklanov and S. Hoe. The Danish Emergency Response Model of the Atmosphere. *J. Envir. Radioactivity* (2007).

The final NKS report for the NKS-B NORDRISK activity is available [here](#).

NKS-B PardNor: Improved ingestion dose modelling for Nordic decision support

Kasper G. Andersson¹, Sven P. Nielsen¹, Hanne Solheim Hansen², Mats Isaksson³, Hans Pauli Joensen⁴, Eila Kostianen⁵, Sigurður Emil Pálsson⁶, Vesa Suolanen⁷ and Håvard Thørring²

¹ Risø-DTU National Laboratory, Denmark

² Norwegian Radiation Protection Authority, Norway

³ University of Gothenburg, Department of Radiation Physics, Sweden

⁴ Faculty of Science and Technology, University of Faroe Islands, Faroe Islands

⁵ Radiation and Nuclear Safety Authority (STUK), Finland

⁶ Geislavarnir ríkisins, Iceland

⁷ VTT Technical Research Centre, Finland

kgan@risoe.dtu.dk

Introduction

The NKS-B PardNor activity addresses current shortcomings in modelling of ingestion doses for Nordic decision support. Nordic preparedness authorities apply in principle either the ARGOS or the RODOS decision support system for consequence prognoses and optimisation of countermeasure strategies. In both of these systems, the integrated ingestion dose module is identical with the ECOSYS model developed in Germany shortly after the Chernobyl accident (Müller & Pröhl, 1993). A problem in this context is that practically all generic parameterisation in ECOSYS took place many years ago and does not reflect state-of-the-art knowledge. Also, the ECOSYS model was parameterised for Bavarian conditions, and with respect to a range of input factors, it is clear that location specific information is required to obtain reliable dose estimates. Nevertheless, the model is generally still run in RODOS and ARGOS with its Bavarian default parameters.

Methods

Parameter studies are conducted to improve the foundation for Nordic ingestion dose modelling, and the effects of the findings are recorded through application in an Excel version of the ECOSYS model supplied by its originators.

The following work tasks have been identified as potentially important, and are carried out in the process towards establishing trustworthy Nordic decision support systems:

1. Analyses of typical diets in different Nordic countries
2. Analyses of Nordic import fractions of food products
3. Analyses of animal feeding regimes in the Nordic countries
4. Analyses of seasonal leaf area development in the Nordic countries
5. Better estimates of leaching rates, fixation rates, desorption rates, and resuspension enrichment factors for contaminants in soil
6. Definition of transfer factors in relation to soil classification
7. Improvement of animal metabolism parameters (transfer factors and biological half-lives)
8. Improvement of deposition velocity estimates on crops and open fields, according to particle size
9. Improvement of natural weathering rates (e.g., according to precipitation, time-dependence)

Of these nine work tasks, the top five have been carried out, the following two are being addressed in the current activity period, and the last two will be addressed in the final activity period next year.

Results and discussion

The following shows some examples of PardNor activity results in relation to the first and fifth of the above work tasks.

Nordic diets

Figure 1 shows a comparison of the consumption of wheat and rye flour in the Nordic countries, based on national dietary surveys (Nielsen & Andersson, 2008). Here it is seen that a typical Danish adult consumes more than 3 times as much rye flour as the typical Norwegian adult. Such traditional differences in diet can be very important to take into account in optimising efforts to reduce doses after a contaminating incident. However, as this relationship is 4.3 for the senior adults, but only 2.9 for teenagers, this particular difference between Norwegian and Danish diets seems to be declining, stressing the need for recent dietary data for the modelling. Fairly recent dietary data is available for most Nordic countries. The exception is the Faroe Islands, where the latest, and not very detailed dietary survey seems to have been conducted in 1981-82. Anyway, in the Faroe Islands and Iceland, these grain products are imported from abroad. It is also seen from Figure 1 that due to differences in climate, in the northernmost countries (Norway and Finland), practically all wheat used for consumption by humans is spring wheat, whereas in Denmark, Sweden and Germany, the majority of the wheat produced/consumed is winter wheat. This means that if a contamination occurs in the spring, the wheat plants will in Finland and Norway have undergone very little development, whereas in the more southern countries, where sowing took place already in the previous autumn, and the warmer weather would lead to a more rapid plant development, the wheat plants could be quite mature, and receive a comparatively considerably larger contaminant deposition. This would greatly affect wheat flour contamination levels in the first year harvest.

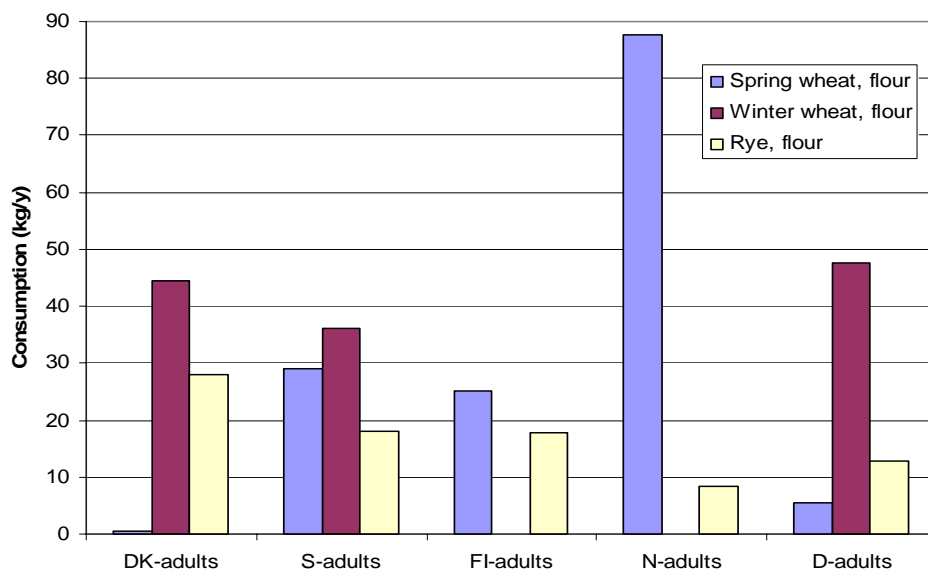

Figure 1. Consumption of wheat and rye flour in the Nordic countries, and German ECOSYS defaults, D (averages for adults).

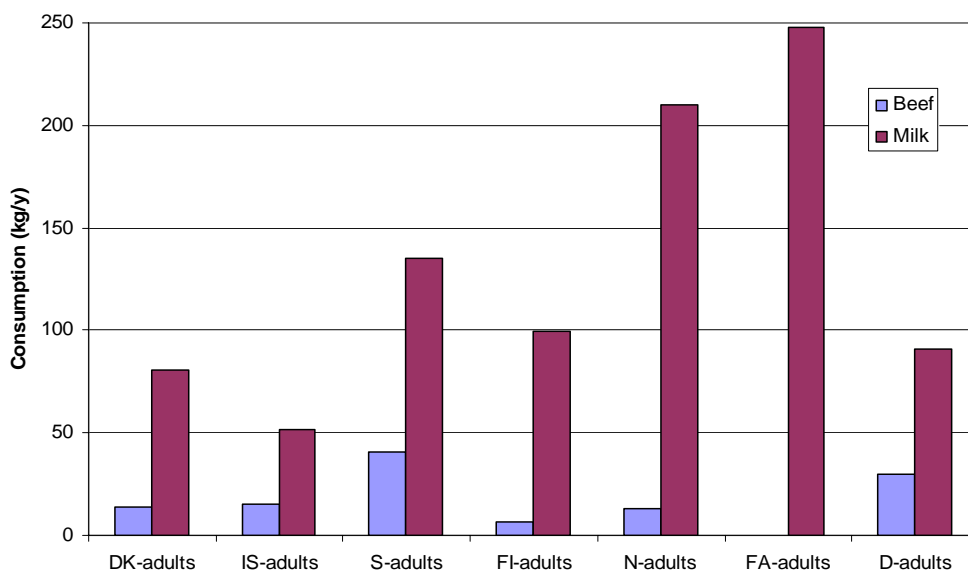

Figure 2. Consumption of beef and milk in the Nordic countries, and German ECOSYS defaults, D (averages for adults).

Figure 2 shows a comparison between the average consumption by adults of beef and milk in the different Nordic countries (and ECOSYS defaults). Here there are differences by a factor of 4-5 between some of the countries. It should also here be noted that the best Faroese data available are several decades old. As the Chernobyl accident demonstrated, the rapid milk food chain may be of very high importance in connection with a contaminating incident. The fact that very young German children consume some 3 times less milk than Nordic children of the same age group again demonstrates the importance of applying location specific input data for the ECOSYS model, as ECOSYS defaults are for some products clearly unsuited.

Contaminant fixation rates in soil

In ECOSYS, fixation rates govern the loss of bioavailability of the contaminants due to strong attachment of radionuclides particularly to clay minerals. Fixation half-lives are generally (with the exception of caesium and strontium) by default set to very high values (mostly 1000 years), to reflect the low tendency of fixation in soil of most radionuclides considered in ECOSYS. This is reasonable, and even estimates of doses received over as long a period as a life-time would not be affected by refining these parameter estimates. Specifically for caesium, the selective fixation in clay minerals gives a much shorter fixation half-life. Here, the ECOSYS default value is 8.7 years. Like other ECOSYS parameters, this is based on old assessments, not taking into account the many assessments made after the Chernobyl accident, in which physicochemical forms of the contaminants are representative of those that may be expected in connection with a future large nuclear power plant accident.

Applying a modified version of the sequential extraction technique described by Tessier, it was suggested by Oughton et al. (1990) that the ‘strongly fixed’ fraction of a contaminant in soil could be defined as the part of the contamination that can not be extracted with the most inert solutions, but requires addition of strong acid to go into solution. Such modified Tessier extractions have also been applied by other workers, and it has become a standard technique for sequential extractions to assess the mobility in soil and sediments of contaminants like ^{137}Cs and ^{90}Sr . If it is assumed that the mobile (easily extractable) fraction decreases exponentially over time, sequential extractions carried out by various workers at different times after the contamination from the Chernobyl accident took place on soil samples from Nordic, Ukrainian, Russian and other European areas with different characteristics (see Nielsen & Andersson, 2009, for references), suggest that radiocaesium fixation half-lives would typically range between about 1.3 and 2.7 years for most soils with significant mineral phases, and some 4-5 years for very sandy or organic soils.

If the fixation half-life for caesium is changed from 8.7 years to 2 years, in an example scenario where dry deposition of ^{137}Cs occurs on the 1st of January, and diets, import fractions and animal feeding regimes reflect Danish conditions (as defined by PardNor activity), whereas the rest of the parameters are ECOSYS defaults, ECOSYS would estimate the influence on ingestion dose components as shown in Table 1.

Table 1. Percentage change in ingestion dose contributions to adults integrated over respectively 2 and 50 years, by setting the ^{137}Cs fixation half-life to 2 years (scenario described above).

	Winter wheat flour	Fruits	Cow's milk	Beef (cow)	Total
2 years	18.5%	23.7%	0.5%	0.5%	0.5%
50 years	67.6%	69.9%	7.7%	8.0%	9.5%

The figures in Table 1 show that particularly some of the long term dose contribution estimates could be far off if a fixation half-life value of 8.7 years is used for a mineral soil. It is also worth noting that this change in fixation half-life changes the estimate of the total ingestion dose received over the period from 10 to 20 years after the deposition by a factor of about 200. Such a difference in estimates could be highly important in connection with decision support to lift long-term restrictions and return an area to more normal living conditions.

The data for sequential extractions of strontium is sparser, but investigations by Oughton et al. (1990), Oughton et al. (1992) and Salbu et al. (1994) suggest a fixation half-life of respectively 20 years, 11 years and 23 years for soils with mineral content. This is in good agreement with the default fixation half-life of 20 years applied in the ECOSYS model.

References

- Müller, H. & Pröhl, G. (1993). ECOSYS-87: a dynamic model for assessing radiological consequences of nuclear accidents, *Health Physics* 64(3), pp. 232-252.
- Nielsen, S.P. & Andersson, K.G. (eds.) (2008). *PardNor - PARAmeters for ingestion Dose models for NORdic areas. Status report for the NKS-B activity 2007.* NKS report NKS-174, Nordic Nuclear Safety Research (NKS), Roskilde, Denmark, ISBN 978-87-7893-240-2.
- Nielsen, S.P. & Andersson, K.G. (eds.) (2009). *PardNor - PARAmeters for ingestion Dose models for NORdic areas. Status report for the NKS-B activity 2008.* NKS report (in press), Nordic Nuclear Safety Research (NKS), Roskilde, Denmark, ISBN.
- Oughton, D.H., Salbu, B., Riise, G., Lien, H., Østby, G. & Nøren, A. (1992). Radionuclide mobility and bioavailability in Norwegian and Soviet soils, *Analyst* 117, pp. 481-486.
- Oughton, D.H., Salbu, B. & Strand, P. (1990). Mobility factors for estimating the bioavailability of radionuclides in soil, in proceedings of the BIOMOVs Symposium on the validity of environmental transfer models in Stockholm, ISBN 91-630-0437-2, SSI, Stockholm, pp. 235-239.
- Salbu, B., Oughton, D.H., Ratnikov, A.V., Zhigareva, T.L., Kruglov, S.V., Petrov, K.V., Grebenshakikova, N.V., Firsakova, S.K., Astasheva, N.P., Loshchilov, N.A., Hove, K. & Strand, P. (1994). Mobility of ¹³⁷Cs and ⁹⁰Sr in agricultural soils in the Ukraine, Belarus and Russia, 1991, *Health Physics* 67(5), pp. 518-528.

Final NKS reports for the NKS-B PardNor activity are available [here](#) and [here](#).

NKS-R WASCO: Wire system ageing assessment and condition monitoring

Paolo F. Fantoni

IFE OECD Halden Reactor Project, Norway

Paolo.Fantoni@hrp.no

Introduction

The interest of safety aspects of wire systems aging (especially those wire systems used for control and instrumentation) is increasing worldwide because of their impact on several industrial fields, like power generation, transportation and defense. Although the environment conditions and degradation mechanisms of installed cables can be different from target to target, the negative consequences of wire failures, both from a safety and performance standpoint, are so important that almost all the countries in the industrialized world have some research project in progress in this area.

In the nuclear field, where cables are normally qualified before installation for an expected life of 40 years, there are a number of issues that are not completely solved today. These issues include:

- The effect of the particular adverse environment conditions (high radiation, humidity and temperature), especially during and after a Design Basis Accident (DBA).
- Extending the plant life after 40 years involves the requirement to assess and qualify the cable conditions for a longer time.
- Many cables condition monitoring techniques do exist today, but none of them is considered accurate and reliable enough for all the cable materials in use and conditions. In addition to that, only few of them are non-destructive techniques and are applicable in situ.
- Accelerated aging techniques, for qualification purposes under DBA conditions, are often not conservative and should be complemented with reliable condition monitoring methods.

A workshop on Wire System Ageing Assessment and Condition Monitoring was organized by the Halden Project at Zurzach, Switzerland, the 28-29 October 2004. This meeting was a good basis for the planning of the activities to be performed on this topic.

In 2005, the WASCO project has been focusing the development of a technique based on high frequency reflectometry and the development of a prototype software to test this technique. During 2005 the following 2 tests have been designed and performed:

- Norsk Hydro tests on long cables
- EPRI tests on thermally aged nuclear plant cables

A final report [5] was written and published with the achieved results

In 2006 the system was further developed and on-site tests at Barseback and Ringhals NPPs were performed and analyzed, as reported in the project final report [6].

Objective of the 2008 WASCO project

The main objective of the 2008 project is to evaluate and compare the capability of few popular CM techniques in the assessment of cable aging and failure as a consequence of thermal aging and mechanical damage. In particular, the detection and assessment of local hot spots, due to local higher environment temperature, will be evaluated. The techniques that will be tested in this experiment are:

- Elongation-At-Break (EAB). It will be used as a reference method to correlate the 3 other techniques to the widely accepted 50% absolute EAB as limiting value.
- The Indenter. It is a local mechanical test that is in use in several power plants. The Indenter has always shown a good correlation with EPR, EPDM and PVC insulation types, but less confidence with XLPE types.
- TDR and LIRA. Both these methods are based on electrical properties of the insulation. TDR is a time domain method used for many years to detect anomalies along electrical wires, while LIRA is supposed to be a more sophisticated and sensitive method that monitors cable impedance variations to detect and localise cable defects or degradations.

Comparison Results between TDR and LIRA

TDR Measurements

It is difficult to extract conclusions with the results obtained from TDR tests. Figure 1 shows the results obtained with the thermal spots on 4 samples. Although some reflections are visible in all the traces, the spots at 10m are not easy to identify.

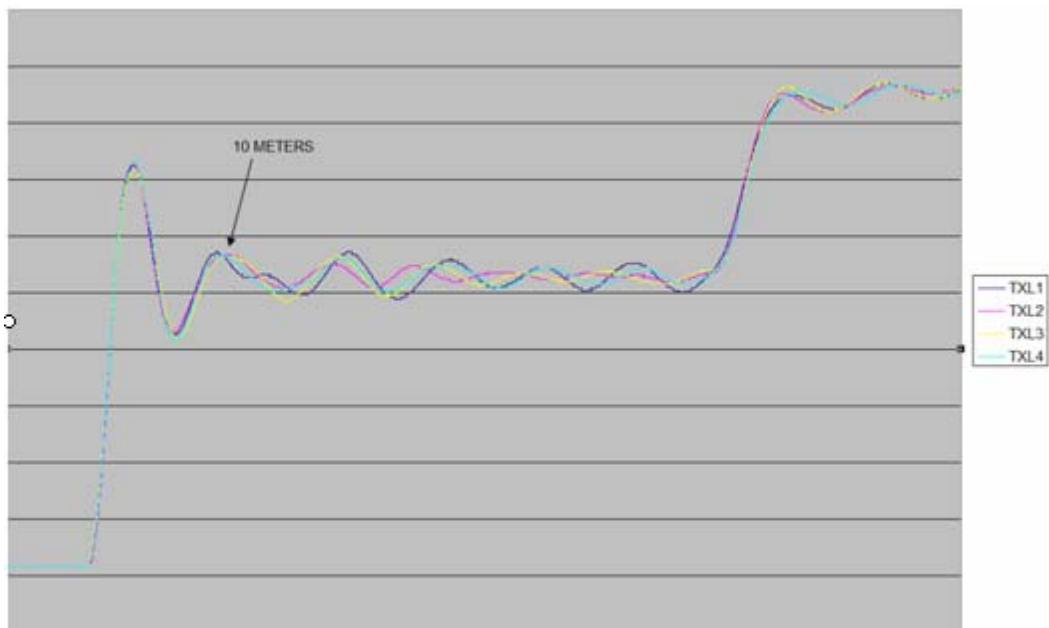

Figure 1. TDR representation of TXL cables

LIRA Measurements

The hot spots in the 4 aged samples were all clearly visible in LIRA. Figure 2 shows the signature for one of them (TXL1). The shape of the spikes indicates that the size of this spot is close to 1.5m (the size at which the two spot ends start to be detected with a double peak) and the spot position is accurately detected. The large spike at 30m is the termination reflection.

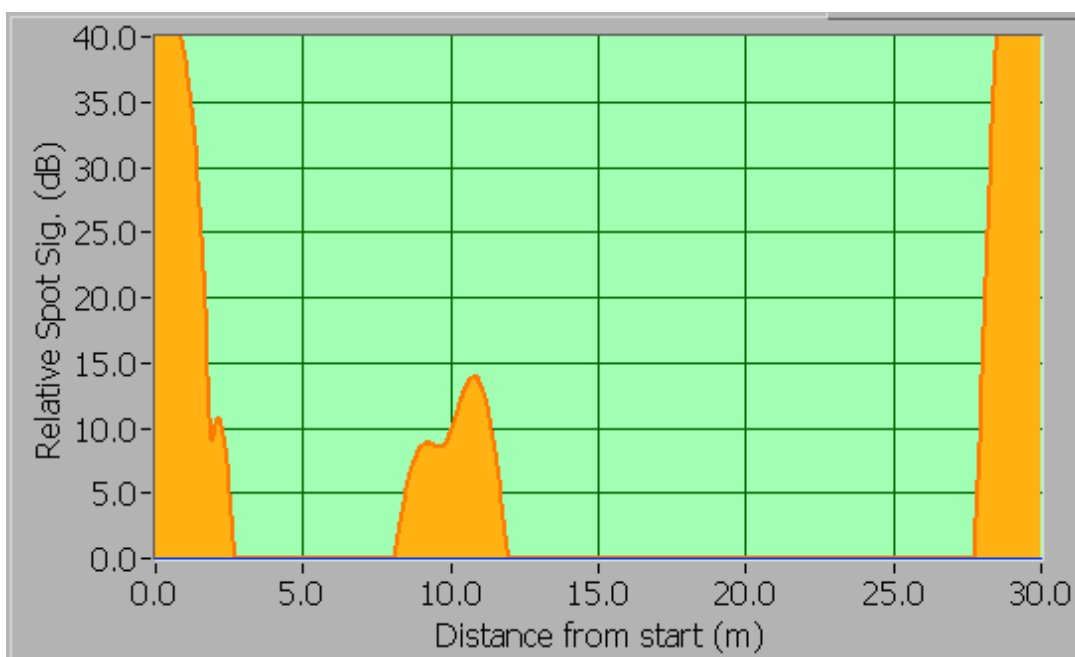

Figure 2. TXL1 spot in View Mode (LIRA)

Mechanical Faults Test

Two types of mechanical damage were tested: TXM1 had a cut down to the insulation of 2 conductors, while TXM2 a gouge over 2 cm of length, see Figure 3.



Figure 3 TXM2 gouge of 2 wires (dry)

TDR Measurements

Figure 4 shows the traces for TXM1 and TXM2. Although some possible features are visible in the damaged areas, no clear diagnosis can be assessed.

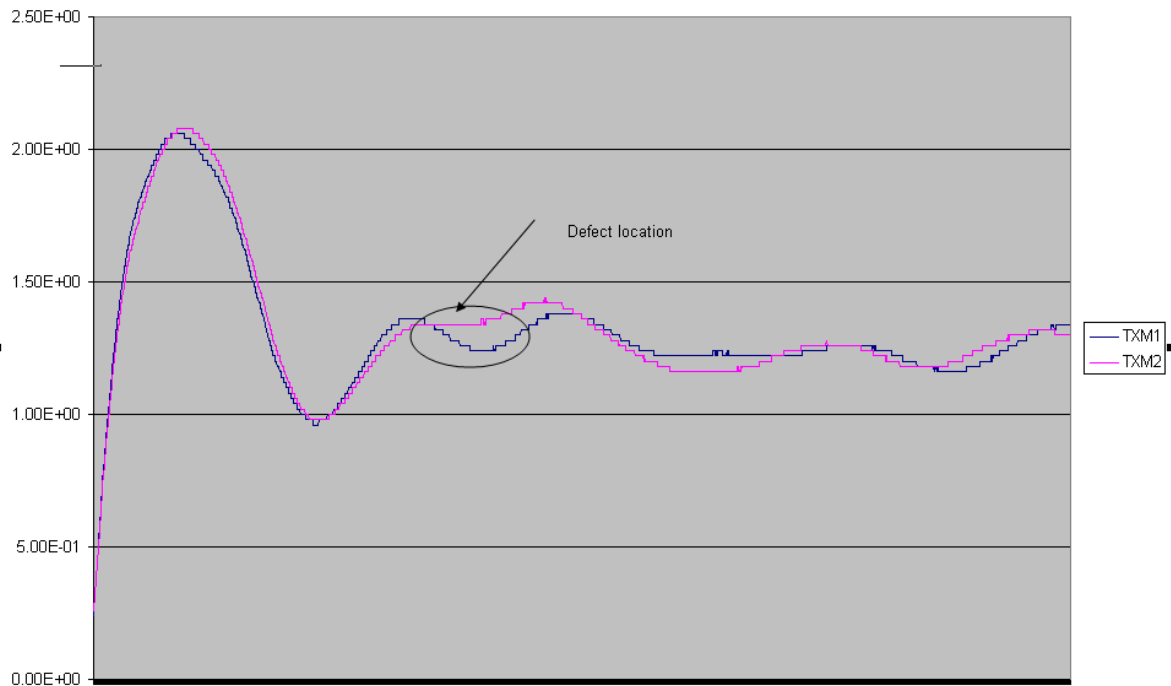

Figure 4. TDR trace for TXM1 and TXM2

LIRA Measurements

Figure 5 shows TXM1 before (red trace) and after the mechanical damage at 10m. The spot feature is clearly visible at the right position.

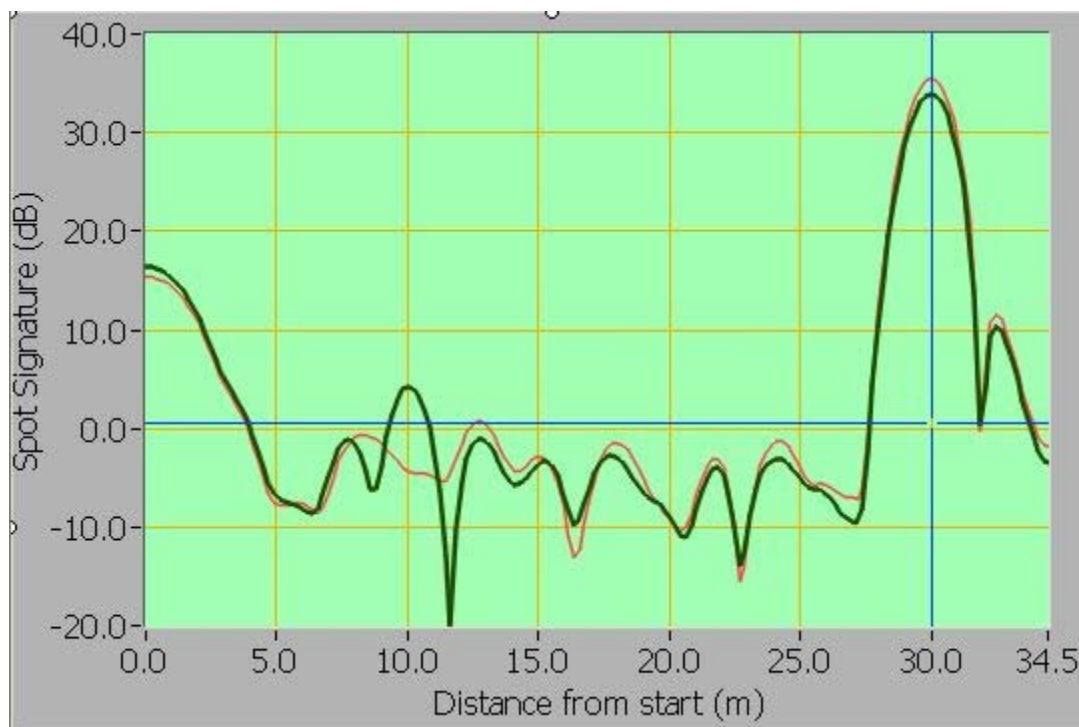

Figure 5 TXM1 cut at 10m(dry)

Conclusions

The experiment performed at Tecnatom showed the performance and limitations of current condition monitoring tools for cable aging. Among the emerging techniques, LIRA confirmed its good performance in hot spot detection and localization.

This project showed also that more research is needed in this field, primarily to develop a stable indicator of the global aging condition of a cable in harsh environment.

References

- [1] P.F. FANTONI, "NPP Wire System Aging Assessment and Condition Monitoring: State-Of-the-Art Report" Halden Reactor Project (HWR-746) (2004).
- [2] "Review of Federal Programs for Wire System Safety" United States White House (2000)
- [3] D. ROGOVIN and R. LOFARO, "Evaluation of the Broadband Impedance Spectroscopy Prognostic/Diagnostic Technique for Electric Cables Used in NPP" USNRC (NUREG/CR-6904) (2006)
- [4] K.S. CHANG-LIAO, T.K. CHUNG, H.P. CHOU, "Cable Aging Assessment by Electrical Capacitance Measuring Technique" *Proc. NPIC&HMIT 2000*, Washington D.C., Nov. 2000, (2000).
- [5] P.F. FANTONI, "Wire System Aging Assessment and Condition Monitoring: The Line Resonance Analysis Method (LIRA)" Halden Reactor Project (HWR-788) (2005).
- [6] P.F. FANTONI and A. NORDLUND, "Wire System Aging Assessment and Condition Monitoring (WASCO)" Nordic Nuclear Safety Research (NKS-130) (2006).
- [7] P.F. FANTONI and G.J. TOMAN, "Wire System Aging Assessment and Condition Monitoring Using Line Resonance Analysis (LIRA)", NPIC&HMIT 2006 Conference, Albuquerque, USA, 12-16 November 2006.
- [8] *Line Impedance Resonance Analysis (LIRA) for Detection of Cable Damage and Degradation*, EPRI, Palo Alto, CA: 2007 1015209.
- [9] G.J. TOMAN, P.F. FANTONI, "Cable Aging Assessment and Condition Monitoring Using Line Resonance Analysis (LIRA)", ICONE16, Orlando, Florida, May 11-15, 2008.

NKS-R IACIP: Comparison of VNEM to Measured Data from Ringhals Unit 3

Makoto Tsuiki and William H. Beere
IFE OECD Halden Reactor Project, Norway
Makoto.Tsuiki@hrp.no

Introduction

The in-core power distribution is one of the most important parameters calculated in the design and the operation of nuclear reactors, because it is the basis for estimating other requisite parameters, e.g., the probability of the failure of fuel elements, including their claddings both in the normal operations and in the accident situations.

Presently, the in-core power distribution is calculated by an approximation method (the neutron diffusion theory), because available computing power has not been sufficient to use rigorous method of the neutron transport theory^[1]. A margin for the error caused by the approximation is thus necessary in operating nuclear reactors e.g., to secure the integrity of fuel elements. It is obvious that reducing the margin for such an error by improving the accuracy of the calculation will contribute to improve the safety of nuclear reactor operations.

The performance of a PC, on the other hand, has been improving and, recently, has become so high that there is a possibility of solving the rigorous neutron transport equations with a normal PC.

With these backgrounds, a method (VNEM: Variational Nodal Expansion Method) of calculating the in-core power distribution by solving the rigorous neutron transport equations has been developed, and verified by numerical benchmark problems^[2]. As shown in the reference [2], the results were excellent and the next stage should be the verification by the comparison to the real plant data, where inter-Nordic cooperation seems necessary.

In the year 2008, as the 1st part of the verification work of VNEM, comparisons have been made of VNEM prototype system to the measured data obtained from Ringhals unit 3 NPP at its beginning of life, hot-stand-by state^[3]. Three cases with difference control rod bank positions and Boron concentrations have been compared:

- Case 1: nearly all rod banks withdrawn, Boron = 1315 ppm
- Case 2: bank C = nearly half-inserted, bank D = fully inserted, Boron = 1131 ppm
- Case 3: banks C and D = fully inserted, Boron = 1060 ppm

The results can be summarized as:

	Error: maximum detector reading (%)	Error: keff (%)
Case 1	-2.1	-0.175
Case 2	1.5	-0.022
Case 3	-0.5	-0.044

Excellent agreement was observed in the comparison of the neutron detector readings and the core eigenvalues.

The method of core modelling and parameters used in calculation of VNEM is completely the same as the "PWR standard option" determined from similar comparisons of VNEM and other PWRs. No empirical, or any sort of adjustment was done. The computing time of the present version of the code has been measured to be about 10 minutes per case (1/4 core symmetry is assumed) for a modern PC with dual processors. This makes VNEM a practical tool for more accurate core design and even on-line core monitoring.

Comparison Procedure

The composition and the geometry of fuel / core of Ringhals-3 had been transferred from Ringhals NPP to IFE, Halden for 3 cases shown in the previous section. The fuel-pin-cell-homogenized 7 group macroscopic

cross sections are calculated by HELIOS^[4] lattice code with ENDFB-6 library. The measured readings of the traversing neutron fission chambers are also transferred.

As HELIOS is designed to provide the assembly-homogenized cross sections to the conventional nodal diffusion methods, we have to run a small computer code VCOEF3D to calculate parameters (called VNEM coefficients) needed in VNEM calculation. The VNEM coefficients are derived from the PL-transport theory and variational principle (Ritz method) to minimize the errors caused by the assembly-homogenization in a manner described in the reference [3] for all the fuel types included in the core.

The VNEM3D code solves the nodal PL transport equations in whole core region and calculates the core power distribution and the core eigenvalue (keff).

Finally a utility code makes the comparison between the measured (from Ringhals NPP), and the calculated (by VNEM3D) detector readings.

Comparison Results

The most important results (the error in the maximum detector reading and the core eigenvalue) are shown in the 1st section of this document. Figures 1, (a) through (c) show the comparisons of core average axial detector readings for cases 1 through 3, respectively. The detector (fission chambers) readings are calculated by the fission rate of infinitely-diluted U²³⁵ in the detector thimble. The misalignment of the axial position of the measured readings is corrected so that the position of the dips caused by the spacer grid becomes reasonable. A very good agreement was obtained also in the radial distribution of the readings. Refer to the reference [3] for more detailed comparison results.

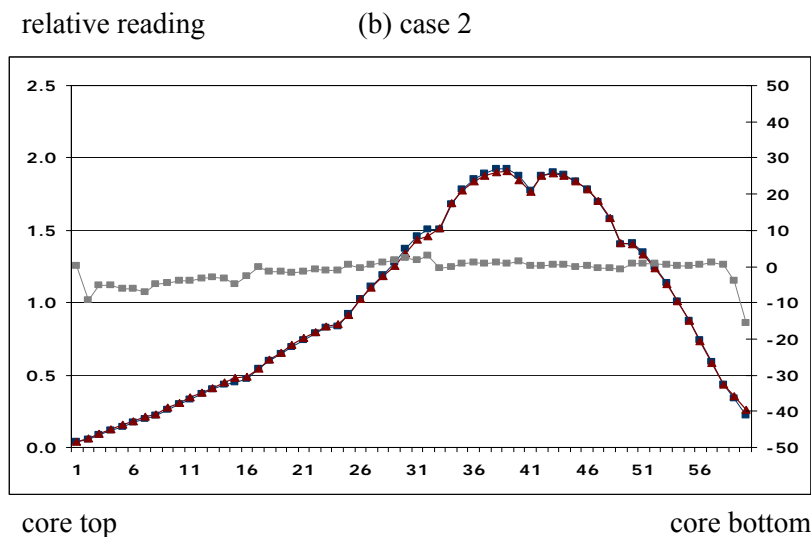
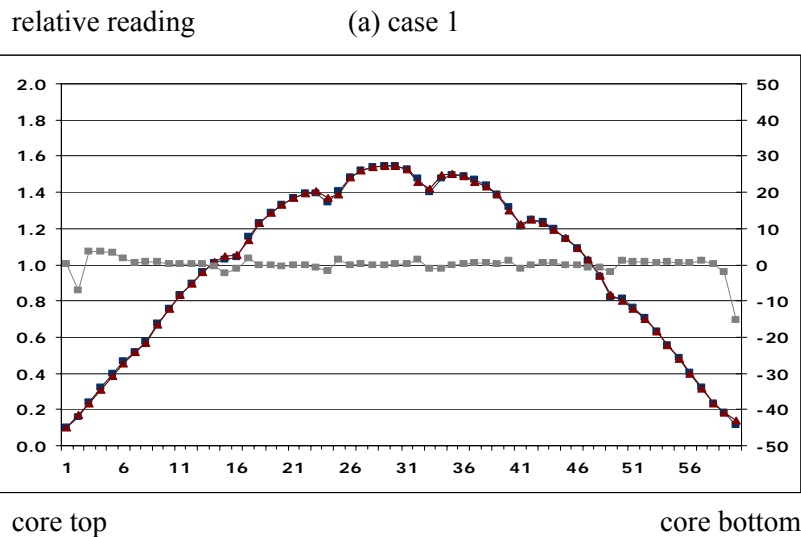

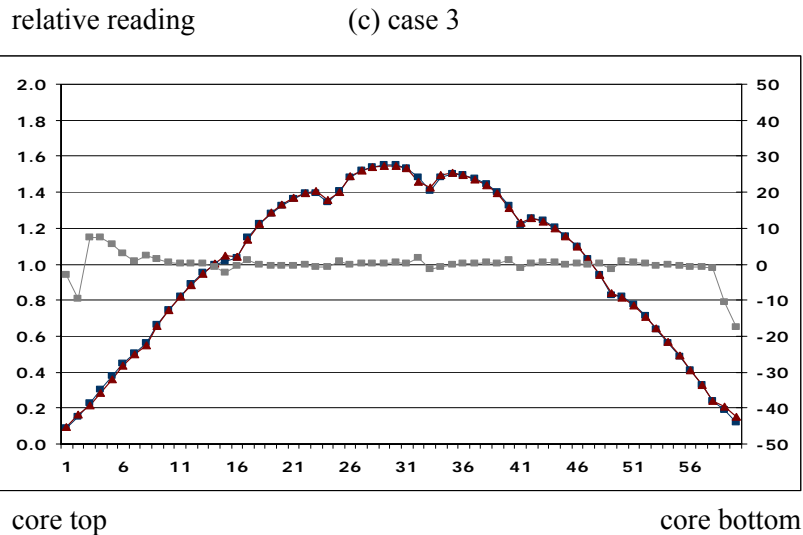

Figures 1a, b and c. Core average axial detector readings comparison; triangle: VNEM, dark square: measurement, grey square: error (%)

Conclusions

The agreement is excellent both for the detector readings and the core eigenvalue. The computing time is about 10 min. per case (1/4 core symmetry is assumed), which seems quite satisfactory for almost all the applications in static core analysis.

The transport effect (the effect of including the angular distribution of neutrons) is significant, i.e., a P3 calculation seems necessary.

The result of a transport calculation is very sensitive to the number of neutron energy groups. The calculations in this verification are performed using 7 energy groups. It is very difficult to reduce the number of energy groups to less than 5 with reasonable accuracy maintained.

References

1. G. I. Bell and S. Glasstone, "Nuclear Reactor Theory", Robert E. Krieger Publishing Company, Huntington, New York, 1979.
2. M. Tsuiki and W. Beere, "A Multi-Dimensional Variational Nodal Transport Method with Heterogeneous Assemblies", *Proc. Conf. XII Meeting on Reactor Physics Calculations in the Nordic Countries*, Halden, Norway, 19-20 May 2005.
3. M. Tsuiki and W. H. Beere: "Comparison of VNEM to Measured Data from Ringhals Unit 3," AR-VNEM-NKS-R-01-08 (r1), report to the NKS-R program manager (2008).
4. F. D. Giust, R. J. J. Stamm'ler, and A. A. Ferri: "HELIOS1.7 User Guide and Manual," Studsvik and Scandpower (2001).

NKS-B GammaRate: Safe use of portable gamma radiation ratemeters for environmental monitoring.

Hans Bjerke¹, Kurt Pedersen², Jan Erik Grindborg³, Þorgeir Sigurðsson⁴ and Antti Kosunen⁵

¹Norwegian Radiation Protection Authority, Norway

²Danish Radiation Protection Institute, Denmark

³Swedish Radiation Safety Authority, Sweden

⁴Icelandic Radiation Protection Institute, Iceland

⁵STUK - Radiation and Nuclear Safety Authority, Finland.

Hans.Bjerke@nrpa.no

The aim

The aim of GammaRate is to harmonize calibration of handheld dose rate meters used in emergency situations and propose guidance documents intended for emergency personnel. The guidance will be for use and maintenance of the dosimeters. The activity began in 2008 and is planned to last for three years.

Background

The emergency organisations are responsible for risk assessments in radiological accidents. Most of data collected as the basis for the assessments, is mapping of the environmental equivalent dose rates in units of Sv/h (sievert per hour). The values may be given with prefixes: m (1/1000), μ (1/1000 000) and n (1/1000 000 000).

A common understanding of the Sv, and then the risk is depending on the traceability and reliability of this dosimetry. The SSDLs saw a missing harmonised calibration service, and thus a missing basis for the risk assessments in the Nordic emergency organisations. NKS supported this understanding by granting funding to the GammaRate activity.

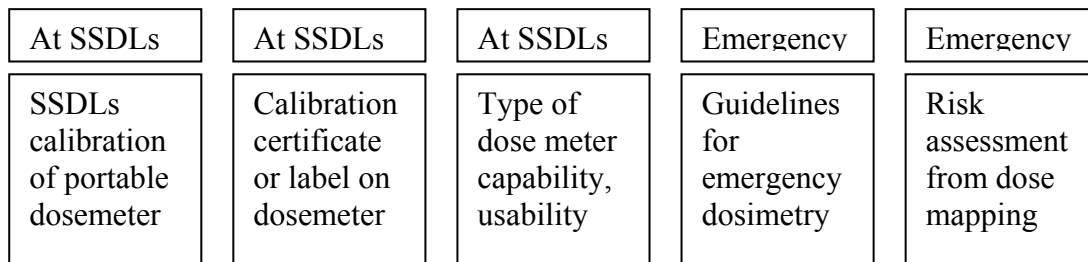

The figure illustrates the links between calibration of dosimeters at SSDLs and emergency organisations risk assessments and action decisions.

The project will concentrate on the three first boxes. Guidelines are available and will be referred to. The experience from Nordic emergency exercises is that training in use of handheld dose rate meters is of more importance than new guidelines.

NKS-B REMSPEC: Analysis of remotely accrued complex gamma-ray spectra.

A proficiency test

M.Dowdall¹, Ø.G.Selnæs¹, S.P. Nielsen⁰, L. del Risco Norrild³, S.E. Pálsson⁴, T.Renvall⁵ and R.Singh Sidhu⁶

¹Norwegian Radiation Protection Authority, Norway

²Riso-DTU National Laboratory, Denmark

³Swedish Radiation Safety Authority, Sweden

⁴Icelandic Radiation Protection Institute, Iceland

⁵STUK - Radiation and Nuclear Safety Authority, Finland

⁶Institute for Energy Technology, Norway

Mark.Dowdall@nrpa.no

Introduction

Despite a perceived simplicity relative to other radioanalytical techniques, the use of gamma spectrometric techniques in emergencies is straightforward and features a number of potential pitfalls. Many labs are primarily involved in the routine analysis of samples displaying a simple spectrum of natural nuclides plus some Chernobyl or weapons fallout nuclides. Samples measured soon after an accident are unlikely to resemble these in terms of spectral complexity, range of isotopes and activities. Countries without significant nuclear facilities may lack experience in the analysis of complex spectra which may impact upon emergency response capabilities. Proficiency testing and regular exercising using samples of complex isotope mixtures is a beneficial practice that increases competence and confidence in handling post-accident situations. International post-accident exercises are more complex than those for regular environmental samples. Samples may be drawn from a reactor and distributed to though this is neither easy to conduct in relation to transport nor practicable for short lived isotopes. A possible solution to the problem is the prompt measurement of such a sample with distribution of the spectrum to the participants. While mitigating the problem of sample distribution, the problem of the lack of some measure of the true value remains. A potential solution is the use of totally synthetic spectra which accurately represent the isotope suite and activities likely to be featured in a post-accident situation. Nikkinen [1] reports on the use of such spectra for the testing of emergency preparedness and a proficiency test employing synthetic spectra was conducted by the Comprehensive Test Ban Treaty Organisation (CTBTO) as reported in Karhu et al [2]. Two large-scale initiatives using synthetic spectra for gamma spectrometry quality assurance have been the US Dept. of Energy/Environmental Measurements Laboratory's (EML) Gamma Spectrometry Data Validation Program [3] and the Synthetic and Virtual Environmental Media (SAVEM) program[4]. Within the context of the points raised in the preceding text, it was proposed to conduct an international exercise using a synthetic complex gamma ray spectrum in order to both provide an opportunity to exercise and to elaborate upon the advantages and disadvantages of such an approach.

Methods

Two spectra were created for REMSPEC both using the same simulation conditions (low background HPGe detector, 40% rel. eff.). The first was a calibration spectrum of approximately 100 Bq each of ¹³⁷Cs, ¹³³Ba and ⁸⁸Y and 1000 Bq ⁴⁰K obtained from a simulated measurement period of 10 hours. The second was the actual test spectrum containing a suite of isotopes based upon an analysis of a hypothetical accident involving a nuclear power plant, as described fully by Larsen et al [5]. The test spectrum contained the following isotopes and activities (Table 1.). Simulation was conducted using the modified MCNP code described by Plenteda [6]

Table 1. Isotopes and corresponding activities as simulated in the test spectrum.

Isotope	Bq	Isotope	Bq	Isotope	Bq	Isotope	Bq
¹³¹ I	3046.50	¹³⁷ Cs	251.8	¹⁴¹ Ce	66.4	^{131m} Te	202.0
¹³² I	2937.0	¹⁰³ Ru	297.8	¹⁴³ Ce	43.0	¹³² Te	2850.0
¹³³ I	2443.60	¹²⁷ Sb	218.0	⁹¹ Y	376.0	¹³¹ Te	45.6
¹³⁵ I	217.6	¹⁴⁰ Ba	914.1	⁹¹ Sr	58.9	^{91m} Y	36.9
¹³⁴ Cs	321.9	¹⁴⁰ La	209.1	⁹⁵ Zr	80.6	¹³⁵ Xe	193.0
¹³⁶ Cs	73.4	¹³³ Xe	27.6	⁹⁵ Nb	409.3		

Simulated live time for the test spectrum was 3600 s. No dead time corrections were required, no laboratory/detector background was simulated as it was assumed that the short count times and normal levels of detector shielding would result in a negligible background signal. Signals such as the 511 keV annihilation peak were included. True coincidence summation effects were included for all nuclides. For ^{134}Cs only the β^- decay was employed; the EC branch was not simulated due to insignificant gamma emissions. For $^{131\text{m}}\text{Te}$ the significant IT branch results in no major gamma lines and was not simulated. Two weeks prior to the exercise, full efficiency data (peak and total) was disseminated along with the calibration spectrum. Participants were instructed to use this spectrum for energy/shape calibration and not efficiency calibration for which the supplied data was to be used. Upon distribution of the test spectrum, participants were informed they had 3 hours to return such results as they could and 1 week to conduct a more thorough analysis should they so wish. Spectra were provided in all the major spectrum formats and some generic formats.

Results and Discussion

One laboratory, Number 8, withdrew from the exercise for technical reasons. Laboratory Number 5 returned results for two different analytical setups, denoted hereafter as 5a and 5b. Qualitative results are presented in Table 2 for the 3 hour limit.

Table 2. Qualitative results for the participants as reported within 3 hours. Gray shading indicates a positive identification.

Participant	1	2	3	4	5a	5b	6	7	9	10	11	12
^{131}I												
^{132}I												
^{133}I												
^{135}I												
^{134}Cs												
^{136}Cs												
^{137}Cs												
^{103}Ru												
^{127}Sb												
^{140}Ba												
^{140}La												
^{141}Ce												
^{143}Ce												
^{91}Y												
^{91}Sr												
^{95}Zr												
^{95}Nb												
$^{131\text{m}}\text{Te}$												
^{132}Te												
^{131}Te												
$^{91\text{m}}\text{Y}$												
^{135}Xe												
^{133}Xe												

They indicate that the majority of participant laboratories identified the iodine isotopes of highest activity which constituted the dominant spectral signals. The lower activity ^{135}I was also identified by most participants. The three caesium isotopes did not constitute a problem for the majority with respect to isotope identification. The mother daughter pairings of $^{140}\text{Ba}/^{140}\text{La}$ and $^{95}\text{Nb}/^{95}\text{Zr}$ were also correctly identified in the majority of cases. The above isotopes, as well as ^{103}Ru and ^{141}Ce , are isotopes that are often featured in either national and international intercomparison exercises of general gamma emitting isotopes. In this respect a certain degree of familiarity can be expected for all laboratories and such isotopes should present no significant problems of identification. For isotopes not included in the group above, it can be assumed that many of the participants would not have much experience analyzing for them. Sb-127 was only correctly identified by 4 out of 12 despite presenting a number of visible peaks, of which 3 or 4 are of reasonable intensities. Many participants also failed to correctly identify the low activity ^{143}Ce which exhibits a large number of peaks, three of which have intensities greater than 5% and one of them, at 293.2 keV being a well separated singlet with an intensity of 42.8%. The other cerium isotope present in the test spectrum, ^{141}Ce , was

identified by approximately half of the participating laboratories. Two yttrium peaks were present in the spectrum, corresponding to ^{91}Y and $^{91\text{m}}\text{Y}$, the former with an activity in excess of 350 Bq and the latter with an activity an order of magnitude lower. These two isotopes had the least number of positive identifications of the entire isotope suite. Yttrium-91 has only one low-intensity gamma peak at 1204.8 keV (0.3%) while the metastable isotope also has a single peak at 555.6 keV although this is much stronger at 95% intensity. The situation for ^{91}Y is more difficult as its weak peak occurs within 2 keV of a strong emission from $^{131\text{m}}\text{Te}$. Three tellurium isotopes were in the spectrum, ^{131}Te , $^{131\text{m}}\text{Te}$ and ^{132}Te . The latter was identified by more than half of the participating laboratories while ^{131}Te and $^{131\text{m}}\text{Te}$ were only correctly identified by 3 and 4 laboratories, respectively. First round identification of the xenon isotopes was also relatively poor, ^{135}Xe being correctly identified by approximately half the participating laboratories and ^{133}Xe by about only one third. Identification rates for both isotopes were improved upon slightly after the one week re-analysis period. None of the participants were informed as to the type of filter employed and this led to one known instance of identified xenon isotopes being removed from the list based upon the reasonable assumption that a normal filter would not have retained them. The organisers had not provided information on the filter type to cover two eventualities which could have led to the presence of noble gas isotopes: use of a special filter such as carbon impregnated filters or a paper filter and carbon cartridge in series or a situation where the technicians on site had actually taken the sample some hours before measurement resulting in some ingrowth. Activity results were of a similar pattern to qualitative result: isotopes with which participants were familiar were generally accurately quantified but less frequently encountered isotopes were not quantified so well. The majority were within 25% of the actual value and many were within 10%, margins which are probably acceptable for decision makers in the early phases after an accident. The most obvious feature from reported results is the underestimation of the activity for isotopes ^{132}I , ^{134}Cs , ^{136}Cs and ^{140}La (Figure 1). The magnitude and consistency of participant's underestimation indicates that coincidence correction (to which these isotopes are vulnerable) factors were most probably not applied. Another notable aspect of the quantitative results was the wide variability in the uncertainties quoted in activities even allowing for the fact that some participants may have reported at significance levels other than the requested 1 sigma.

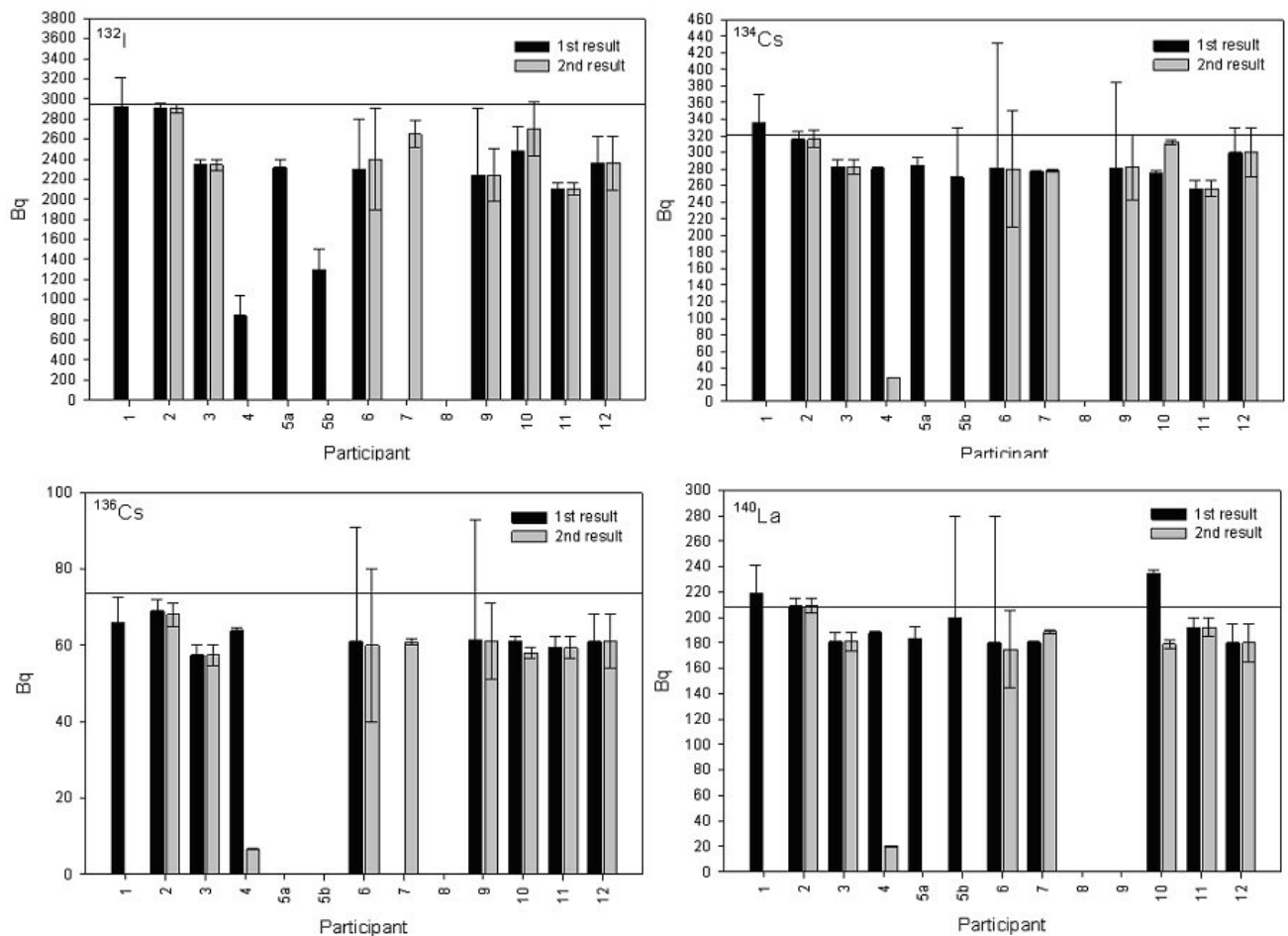

Figure 1. Quantitative results for four isotopes displaying significant coincidence summation problems.

Conclusions.

In general, the use of a synthetic spectrum caused no significant problems with respect to the exercise and facilitated a type of exercise which is not often held due to practical problems. Comments from the participants included suggestions to conduct similar follow-up exercises for the same type of scenario but with a more challenging analysis (more corrections) or exercises to improve analysis capabilities and experience regarding other scenarios. It was also suggested that synthetic spectra could facilitate laboratories testing of such things such as the typical routines of commercial software for summation corrections or for establishing and assessing the necessary procedures for efficient international/laboratory assistance in emergency situations.

References

- 1 M. NIKKINEN, The Use of Synthetic Spectra to Test the Preparedness to Evaluate and Analyze Complex Gamma Spectra, Nordic Nuclear Safety Research, Roskilde, Denmark (2001) NKS Report No. 43, p. 80.
- 2 P. KARHU, L.-E. DE GEER, E. McWILLIAMS, R. PLENTEDA, R. WERZI, (2006) Appl. Radiat. Isotop., 64 (2006) 1334.
- 3 K.M. DECKER, C. G. SANDERSON, P. GREENLAW, (1996), Report of the Department of Energy Office of Environmental Management Gamma, Spectrometry Data Validation Program (1996) USDOE, Report EML-586, p. 92.
- 4 F.H.K. BOOTH, K.M. DECKER, R.J. BATH, D.W. BOTTRELL, K.L. WRIGHT, Synthetic and Virtual Environmental Media (SAVEM), WM'02 Conference, Feb. 24-28, 2002, Tucson, AZ. <http://www.wmsym.org/abstracts/2002/Proceedings/6C/496.pdf> (last accessed: February 2009).
- 5 E. LARSEN, E., NAADLAND HOLO, J. SALTBONES, E. STOKKE, Kola Konsekvensanalyse: Vurdering av Dosemessige Konsekvenser av en Eventuell Ulykke ved Kola Kjernekraftverk, Norwegian Radiation Protection Authority, (1999), StrålevernRapport 1999:Nr 10. p. 59. (In Norwegian).
- 6 R. PLENTEDA, Universitaetsbibliothek der Technischen Universitaet, Vienna, Austria (2002) p. 118 .

Acknowledgments.

The work reported in this project was funded by the B-Programme of the Nordic Nuclear Safety Research (NKS) Contract No: AFT/B(08)5. The authors also wish to acknowledge the time and effort invested by all participants in the exercise and the help and advice provided by F. Ugletveit (NRPA), R. Plenteda and L-E. DeGeer (CTBTO).

The final NKS report for the NKS-B REMSPEAC activity is available [here](#).

NKS-R SafetyGoal: Probabilistic safety goals for nuclear power plants

Michael Knochenhauer¹ and Jan Erik Holmberg²

¹Relcon Scandpower, Sweden

²VTT, Finland

michael.knochenhauer@relcon.se

Introduction and background

The paper deals with an on-going Nordic (Sweden/Finland) project dealing with probabilistic safety criteria for nuclear power plants. The project has relations to an on-going OECD/NEA WGRisk task on probabilistic safety criteria in member countries. An overview is given of some of the issues discussed in project, including consistency in judgement in application of safety goals, safety goals related to PSA level 2, and safety goals related to other man-made risks in society.

The outcome of a probabilistic safety assessment (PSA) for a nuclear power plant (NPP) is a combination of qualitative and quantitative results. Quantitative results are typically presented as the Core Damage Frequency (CDF) or as the frequency of an unacceptable radioactive release, often associated with the Large Early Release Frequency (LERF). In order to judge the acceptability of PSA results, criteria for the interpretation of results and the assessment of their acceptability need to be defined.

Target values for PSA results are in use in most countries having nuclear power plants. In some countries, the safety authorities define these target values or higher level safety goals. In other countries, they have been defined by the nuclear utilities. Ultimately, the goals are intended to define an acceptable level of risk from the operation of a nuclear facility. There are usually also important secondary objectives, such as providing a tool for identifying and ranking issues with safety impact, which includes both procedural and design related issues. Thus, safety goals usually have a dual function, i.e., they define an acceptable safety level, but they also have a wider and more general use as decision criteria.

In most countries, the history of PSA safety goals starts in the 1980s, e.g., NUREG-0880 [1] or INSAG-3 from the IAEA [2]. At that time, PSA models were rather limited in scope. For various reasons, including limitations in analysis scope and capacity problems with the computer codes used for the analysis, the level of detail of the PSA models was also rather limited. In addition, the focus was on level 1 PSA, i.e., on calculation of CDF. Furthermore, the actual use of early PSA:s was generally rather limited, even if the issue of Living PSA received considerable attention during the 1980s.

During the 1990s, PSA models expanded considerably, both regarding operating states and classes of initiating events. The level of detail of the analyses also increased. In parallel, PSA:s were expanded to level 2, making it possible to calculate the frequency of radioactive releases. Thus, the scope, level of detail and areas of use of PSA have changed considerably since the time the safety goals were originally defined. At the same time, there is a growing interest in PSA applications. This has led to an increased interest and need to make judgments concerning the acceptability of risk contributions calculated with PSA.

The paper describes work performed within an on-going Nordic project dealing with the use of probabilistic safety criteria for nuclear power plants [3 and 4]. The project is performed during the period 2005-2009. It was initiated by NKS (Nordic Nuclear Safety Research) and NPSAG (Nordic PSA Group), and has relations to an on-going OECD/NEA WGRisk task on probabilistic safety criteria in member countries.

Consistency in the usage of safety goals

Consistency in judgement over time has been perceived to be one of the main problems in the usage of safety goals. Safety goals defined in the 80s were met in the beginning with PSA:s performed to the standards of that time, i.e., by PSA:s that were quite limited in scope and level of detail compared to today's state of the art.

This issue has been investigated by performing a comparative review of three generations of the same PSA, focusing on the impact from changes over time in component failure data, initiating event (IE) frequency, and of the PSA modelling of the plant, including plant changes and changes in success criteria. It proved to be very time-consuming and in some cases next to impossible to correctly identify the basic causes for changes in PSA results. A multitude of different sub-causes combined and were difficult to differentiate. Thus, rigorous book-keeping is needed in order to keep track of how and why PSA results change. This is especially important in order to differentiate "real" differences due to plant changes and updated component and IE data from differences that are due to general PSA development (scope, level of detail, modelling issues).

Criteria for assessment of results from PSA level 2

Goals related to CDF and LERF are surrogates to societal risk level criteria. To fully validate these goals, calculations of environmental consequences of release sequences would need to be made. The on-going international survey conducted by the OECD/NEA WG Risk shows that acceptance criteria for results from level 2 PSA differ considerably between countries. Both definitions for large release and probability values differ. Further, the status of criteria differs from mandatory requirements to informal targets. Some countries do not use probabilistic criteria at all.

The probability limits used in level 2 PSA vary from 10^{-7} /year to 10^{-5} /year. The highest criteria (10^{-5} /year) have been defined for old reactors only. For new reactors, targets between 10^{-7} /year and 10^{-6} /year have been defined. See Figure 1 for an illustration.

These numbers can be compared to risks experienced or accepted otherwise in society. Thus, from the individual risk point of view, these numbers are acceptable. However, to validate the acceptability of these target values from a societal risk point of view, level 3 PSA assessments need to be made. Results from such assessments are strongly dependent on population data, weather data, and whether or not countermeasures are accounted.

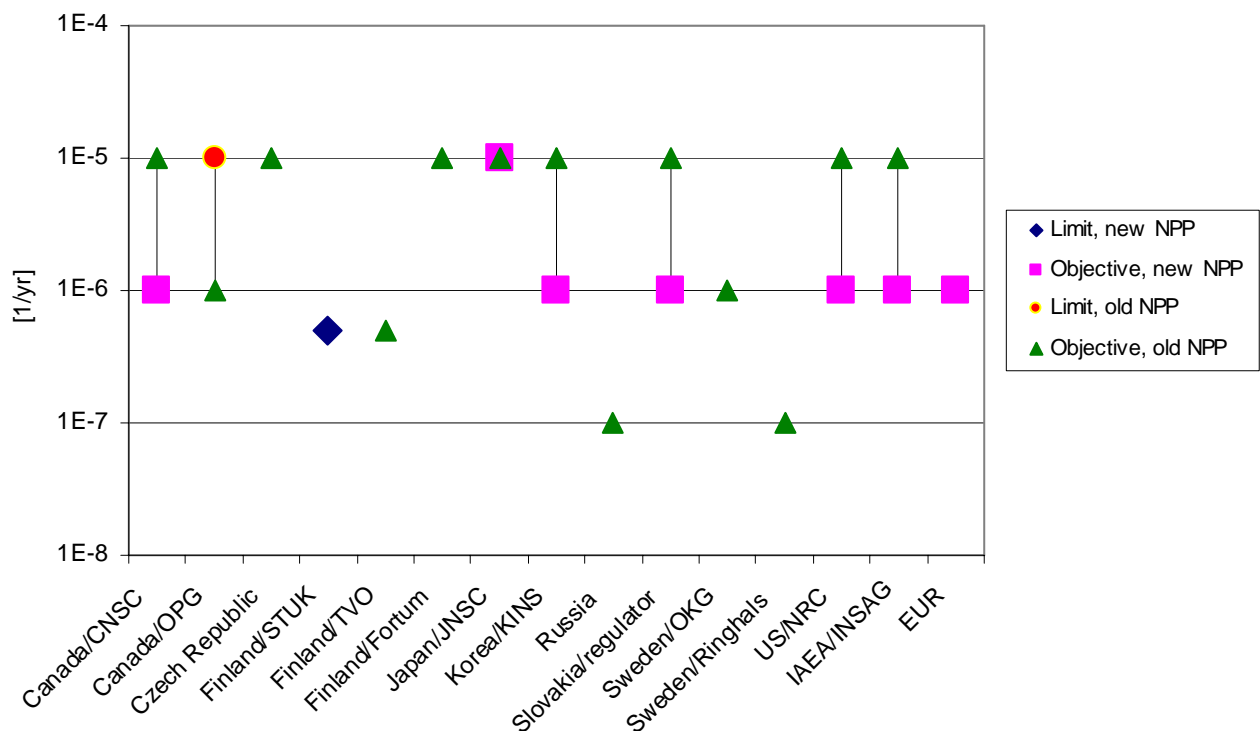

Figure 1. Overview of probabilistic criteria related to level 2 PSA

The aim of the definition for large release of the severe reactor accident is such that, first of all, the release magnitude shall be reduced to such an amount that no acute health effects are caused in the environment. It follows from this requirement that only stochastic late effects can be expected. The criterion “100 TBq Cs-137” used in Finland and the differently worded but almost identical criterion “0,1 % of the core inventory of Cs-137 in an 1800 MWt BWR” used in Sweden, are examples of criteria fulfilling the above requirement. Test calculations with environmental data from a Finnish nuclear power plant site shows that this particular release limit would not cause acute health effects and that late health effects would be minor.

Overview of international safety goals

The on-going OECD/NEA Working group RISK task group on probabilistic safety criteria has the objectives to review the rationales for definition, the current status, and actual experiences regarding the use of probabilistic safety goals and other PSA related numerical risk criteria in the member states. The NKS project participates actively in the task. At present, responses have been received to a questionnaire and been compiled into a draft final report, which is expected to be finalised in the first half of 2009.

Safety goals related to other man-made risks in society

In order to provide perspective on the project's detailed treatment of probabilistic safety goals for nuclear power plants, some information from other areas has been collected, with the focus on the use of probabilistic risk criteria in European offshore oil and gas operations and in the European railway industry.

In offshore oil and gas operations both the number of precursor events requiring handling and of accidents requiring mitigation is high compared to the nuclear industry, resulting in a relatively high focus in the criteria on consequence mitigation. Criteria have a large scope, i.e. they apply to a wide range of accident events and consider a wide range of safety functions. Defence in depth aspects are considered in the criteria by stating requirements for different safety functions. Finally, the ALARP principle is often applied, involving a safety goal with a limit and an objective.

For European rail systems, a standardisation of safety goals has been prompted by the expressed aim of making it possible for trains and personnel to cross national borders. The harmonisation has been achieved by letting an industry working group propose safety goals, which have then been accepted by authorities. The goals suggested are consensus requirements based on an amalgamation of national practices, mainly from Germany and France. Basic principles are based on comparison to general health risk (MEM principle) and a requirement for continuous improvement of safety (GAMAB). Systematic procedures are in place for creating subsidiary goals, which is done by defining a tolerable hazard rate (THR) for each subsystem forming part of the overall system. Finally, it is worth noting, that a framework for cross-acceptance is under development, i.e., development of an agreed common approach for demonstrating the safety levels of the railway system (in addition to the common risk criteria already in place).

Ongoing work

The first phase of the project (2006) described the status, concepts and history of probabilistic safety goals for nuclear power plants. The second and third phases (2007-08) have provided guidance related to the resolution of some of the problems identified, and resulted in a common understanding regarding the definition of safety goals. During phase 4 (2009), the international overview (OECD/NEA WGRisk task on safety criteria) will be finalised, and results and conclusions from this project will be considered. In addition, focus will specifically be put on questions related to application and communication. Guidance to the definition of valid subsidiary criteria will be developed, i.e., lower level criteria that are indirectly related to the societal and individual risk criteria but that are directly applicable with present PSAs. Finally, some additional aspects related to the issue of consistency over time in the usage of safety goals will be explored.

References

1. USNRC 1982: *Safety Goals for Nuclear Power Plants: A Discussion Paper*, U.S. Nuclear Regulatory Commission, February 1982, (Rev. 1); NUREG-0880.
2. IAEA 1988: *Basic Safety Principles for Nuclear Power Plants*. 75-INSAG-3; IAEA Safety Series No. 75-INSAG-3
3. Holmberg, J.-E., Knochenhauer, M.; *Probabilistic Safety Goals; Phase 1 – Status and Experiences in Sweden and Finland*; Nordic Nuclear Safety Research Report NKS-153, 2006 (issued in parallel as SKI research report 2007-06)
4. Holmberg, J.-E., Knochenhauer, M., *Probabilistic Safety Goals. Phase 2 Status Report.* ; Nordic Nuclear Safety Research Report NKS-172, 2008

Final NKS reports for the NKS-R SafetyGoal activity are available [here](#) and [here](#).

NKS-R RiskEval: Interpretation and risk evaluation of technical specification conditions

Ola Bäckström
 Relcon Scandpower, Sweden
ola.backstrom@relcon.se

Background

Studies on risk-informed methods have been a part of NKS activities since late 1980's, but at that time the industry was not ready for the use of these methods. The common understanding right now is that the industry and authorities are ready for adoption of risk-informed strategies. It shall be noted that Finland has developed the use of risk-informed analyses, whereas this area has been less focused in Sweden.

The use of risk informed methods in daily operation at the Nuclear Power Plants as well as for long term evaluation and definition of rules and regulations is increasing. Risk informed methods have been applied on a case by case basis during the past few years, but it is expected that these methods will be applied in a quite different manner in the coming years.

Evaluation of TS from a risk point of view raises several questions:

- How shall the TS conditions be evaluated?
- What aspects shall be taken into consideration?
- Can a prolonged/shortened test interval or AOT (allowed outage time) affect the experienced importance of the equipment?

What is PSA?

PSA stands for Probabilistic safety assessment and is a systematic approach studying all failures (including the probability of failure) and effects of these failures. A Boolean logic is built of the plant in event trees (see figure 1), representing the different sequences that failure and success of different systems can cause, and fault trees (see figure 2) representing the failures of the components etc of a system.

LARGE LOCA CATEGORY AB	REACTOR SHUTDOWN WITH 354	PS-FUNCTION D1	PRESSURE RELIEF OF CONTAINMENT (SYSTEM D2	CORE SPRAY SYSTEM (SYSTEM 323) V	RESIDUAL HEAT REMOVAL WITH 322 W1	No.	Freq.	Conseq.
LAB A I	C1	D1	D2	V	W1			
						1		LAB__RH.
						2		HS2, HS2L, ...
						3		OK
						4		LAB__RH.
						5		HS2, HS2L, ...
						6		HS2, HS2L, ...
						7		HS1

Figure 1. Example of an Event Tree

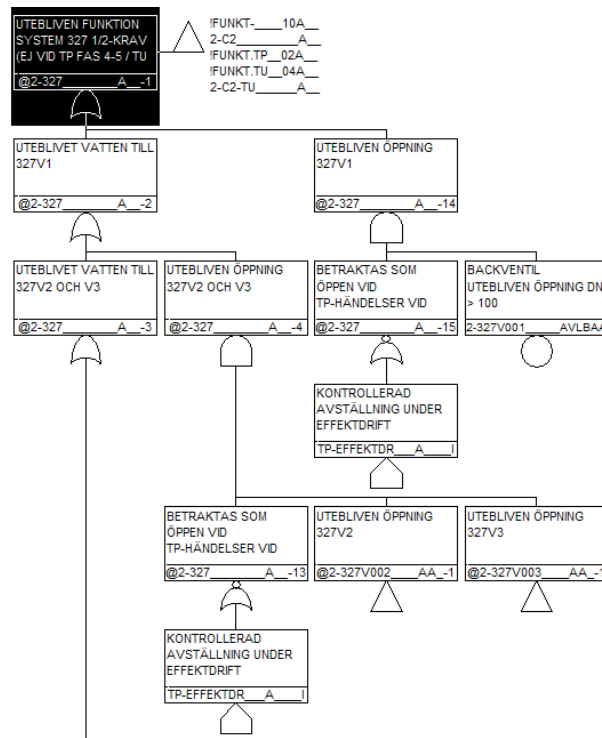

Figure 2. Example of a Fault Tree

This is a tedious task which will give a "complete representation" of plant core damage or release to environment frequency. The model is normally very complex and it provides a tool to be able to analyze the importance of each SSC from a plant perspective.

Technical Specification, TS

The TS sets the rules for a safe operation of a nuclear power plant. The TS is mainly representing the Safety Analysis Report (SAR) requirements (that define the initial conditions for the safety analysis). Example:

- Define how many components/trains that, at least, shall be available
- Define exemptions, AOT: How long time can continued operation with components out of service (acceptable risk)
- Define test interval for emergency core cooling system (acceptable probability of failure)
- Administrative requirements

A constraint that shall be noticed is that: Shutdown is also a challenge to the plant

The Role of PSA

Previously the role of PSA is mainly a "verification" tool, that is used in addition to the other tools. You could say that the process is that the deterministic requirements sets the requirements on the plant, and then PSA is used to verify that it is safe enough. Figure 3 exemplifies this.

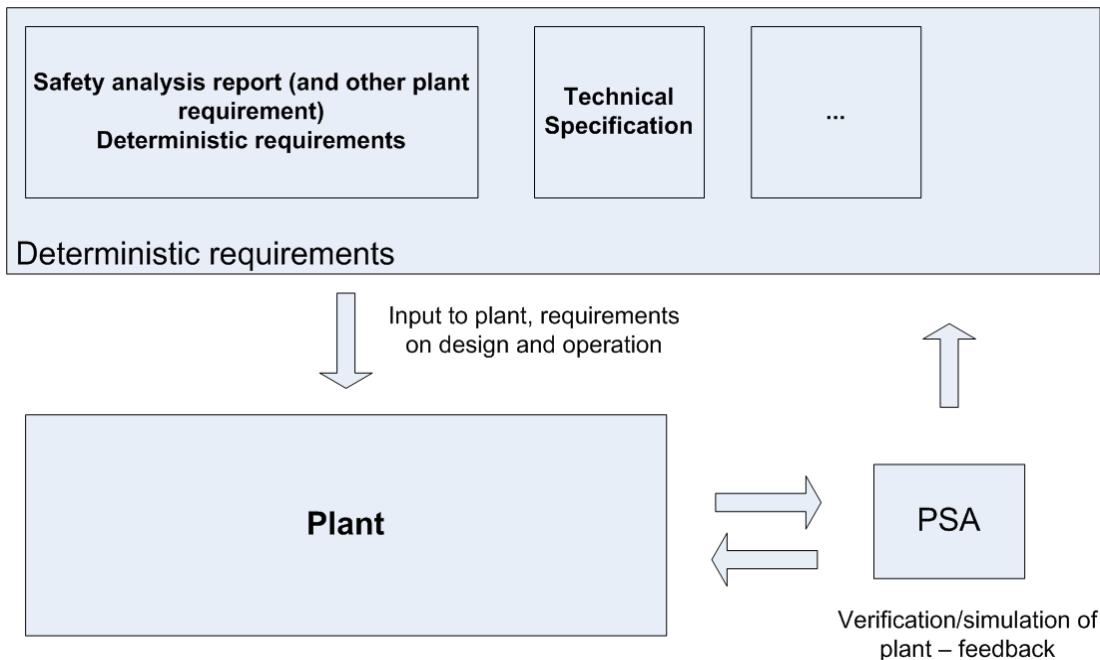

Figure 3. PSA as a verification tool.

This project is studying a more intensive use of the PSA, also in the definition of the deterministic requirements, in this case the TS. This means that the requirements on how and what the PSA really means and its applicability is of much greater importance. Figure 4 shows what the intention of this project is.

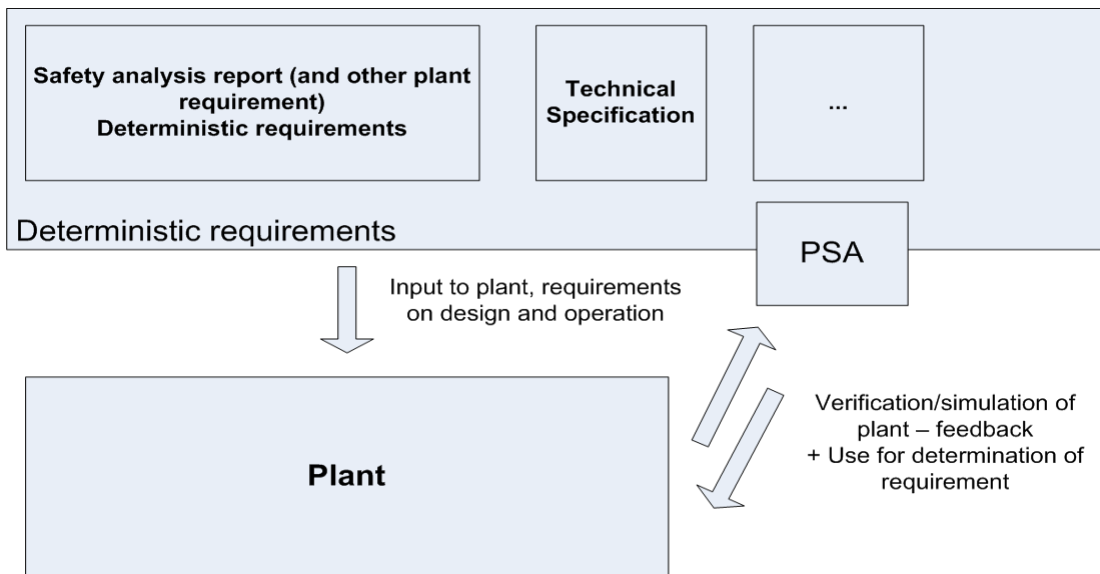

Figure 4. PSA being part of the setting of the requirements in the TS.

Why shall PSA be used in the Evaluation of the TS?

In the evaluation process of TS changes there are many aspects that must be taken into account. It is obvious that the PSA cannot represent all relevant aspects that should be considered – and that should never be the intention. If PSA cannot represent all relevant aspects, does it add any information to use the PSA?

There are very few ways of analyzing the impact of plant changes to the overall risk. Therefore, the PSA adds valuable information.

It can be noticed that both STUK and SKI require changes in the TS to be verified with PSA (SKI does not formally require this but the practice has been this). Also, the US NRC has fully adopted a risk-informed decision process, in which PSA (PRA) plays an important role.

The End Product, the Guidance Document

What has been noticed is that there has not been an agreement on which initiating events, plant states, risk measures etc. that shall be used in an evaluation. This project aims at producing guidance with regard to following:

Contents of TS (what and how of the TS can and shall be analyzed with PSA)

- What equipment shall be analyzed with PSA?
- Shall the PSA affect the contents of the TS (can equipment be excluded from TS if they have no or low importance in PSA)?

What is the evaluation criteria

- Core damage frequency?
- Release frequency?
- Others?

Type of initiating events to include in the analysis

- Only internal events?
- Comprise all types of initiators?
- Else?

Quality issues on the PSA model

- How shall requirements be set on the PSA for it to be appropriate?

Acceptance criteria

The project is ongoing and is scheduled to be finalized during 2009.

NKS-B URBHAND: Handbook for Nordic decision support for contaminated inhabited areas

Kasper G. Andersson¹, Michael Ammann², Steinar Backe³ and Klas Rosén⁴

¹Risø-DTU National Laboratory, Denmark

²STUK - Radiation and Nuclear Safety Authority, Finland

³Institute for Energy Technology, Norway

⁴Swedish University of Agricultural Sciences, Sweden

kgan@risoe.dtu.dk

Introduction

The NKS-B URBHAND activity was finalised in 2008 with the issuing of NKS report 175 (Andersson et al., 2008) - a handbook aimed at addressing the specific needs of Nordic decision makers and their advisors in relation to optimised recovery of inhabited areas contaminated with radioactive pollutants. The focus is on the mitigation of long-term problems. The information given in the handbook is comprehensive, and many details require careful consideration well before implementation of countermeasures in a specific area. Training sessions are therefore recommended. The handbook describes the current relevant Nordic preparedness (dissemination routes) in detail, and suggests methods for measurement of contamination and prognoses of resultant doses, and data for evaluation of countermeasures and associated waste management options. A number of non-technical aspects of contamination in inhabited areas, and of countermeasures for its mitigation, are discussed, and a series of recommendations on the application of all the handbook data in a holistic countermeasure strategy are given.

Methods and background

The URBHAND activity builds on experience obtained through practical and theoretical investigations of the consequences of radioactive contamination in inhabited areas - a field of work that practically arose with the Chernobyl accident, as it was previously erroneously believed that plausible emergencies could only lead to significant contamination in rural areas with low population density. A series of experimental programmes have been conducted over the years that followed the Chernobyl accident (see, e.g., Fogh et al., 1999; Andersson & Roed, 2006). At the same time efforts were made to improve the understanding of urban radioecology in general, and processes governing the doses that would be received in inhabited areas with different characteristics were scrutinised (Andersson et al., 2002). The Chernobyl accident further provided a unique opportunity to examine the various responses of affected persons and impacts on society of a major emergency situation (Howard et al., 2005). Knowledge of this type is essential in emergency decision-making, to address requirements for information and dialogue and evaluate the situation in a holistic perspective, so that optimised solutions can be implemented.

Results and discussion

The URBHAND handbook comprises the following elements:

- Introduction (scope, context, audience, structure, intended application)
- Methodologies, systems and equipment for measurement (planning of measurements, methods, priorities, procedures, training)
- Countermeasures and implementation strategies (descriptions in standardised format of individual countermeasures, advise on formation of strategies)
- Estimation of doses in a contaminated inhabited area (look-up tables for different dose contributions under different conditions)
- Doses and countermeasures specifically for kitchen gardens (practise in the different Nordic countries, dose examples, countermeasure techniques)
- Management of waste generated by countermeasures (wastes from different types of surfaces, repository design recommendations)
- Legal, social, ethical and communication implications (social problems, communication and risk perception, ethical principles)
- Application examples (NPP accident scenario, 'RDD dispersion')
- Description of the current organisational structure of Nordic emergency management.

It was developed in parallel with the generic European EURANOS handbook for inhabited areas (Brown et al., 2009). The EURANOS handbook is in a sense comparatively much more comprehensive, as it is aimed at providing decision support in relation to *all* time-phases of contaminating incidents that might occur in *all* regions of Europe, where for instance traditional practice varies considerably, and environmental conditions can put different constraints on countermeasure application. Acknowledging that considerable location-specific parameterisation and contextualisation is required to integrate the EURANOS handbook in any operational national emergency management system, the authors of the EURANOS handbook strongly recommend that its contents be ‘customised’ and as such only form the background material for more focused handbooks for use in specific countries or regions.

The URBHAND handbook is aimed at presenting information that is directly applicable in the event of an accident contaminating a Nordic inhabited area. This is for instance reflected in a focused, limited selection of countermeasures and a section describing the structure of the emergency management organisation in the Nordic community. This focusing makes the URBHAND handbook much easier to overview and handle in relation to a crisis situation. Moreover, it is important to be aware that in spite of its highly generic approach, the EURANOS handbook has some inherent shortcomings and restrictions. One of these is that due to the initial definitions of the EURANOS project, none of the dose calculations are suited for handling smaller scale contamination events like ‘dirty bombs’, although it is clear from calculations made elsewhere that consequences of ‘dirty bombs’ can be very severe and extend out over large inhabited areas (Andersson et al., 2008a). The URBHAND report offers some initial considerations to address this problem.

Compared with the EURANOS handbook, the URBHAND handbook provides more refined dose calculations for different inhabited environments, enabling direct evaluation of averted doses by introducing a countermeasure on a given environmental surface. As agricultural products would primarily be produced outside the inhabited areas, the primary focus is on the long term external doses. However, it is recognised that some food products may be produced in residential areas, e.g., in kitchen gardens, and the inclusion in URBHAND of the impact of a contaminating incident on kitchen garden products in decision-support handbook material is pioneer work. Figure 1 shows an overview of the different contamination pathways to be considered in an inhabited complex, giving rise to many different types of dose contributions.

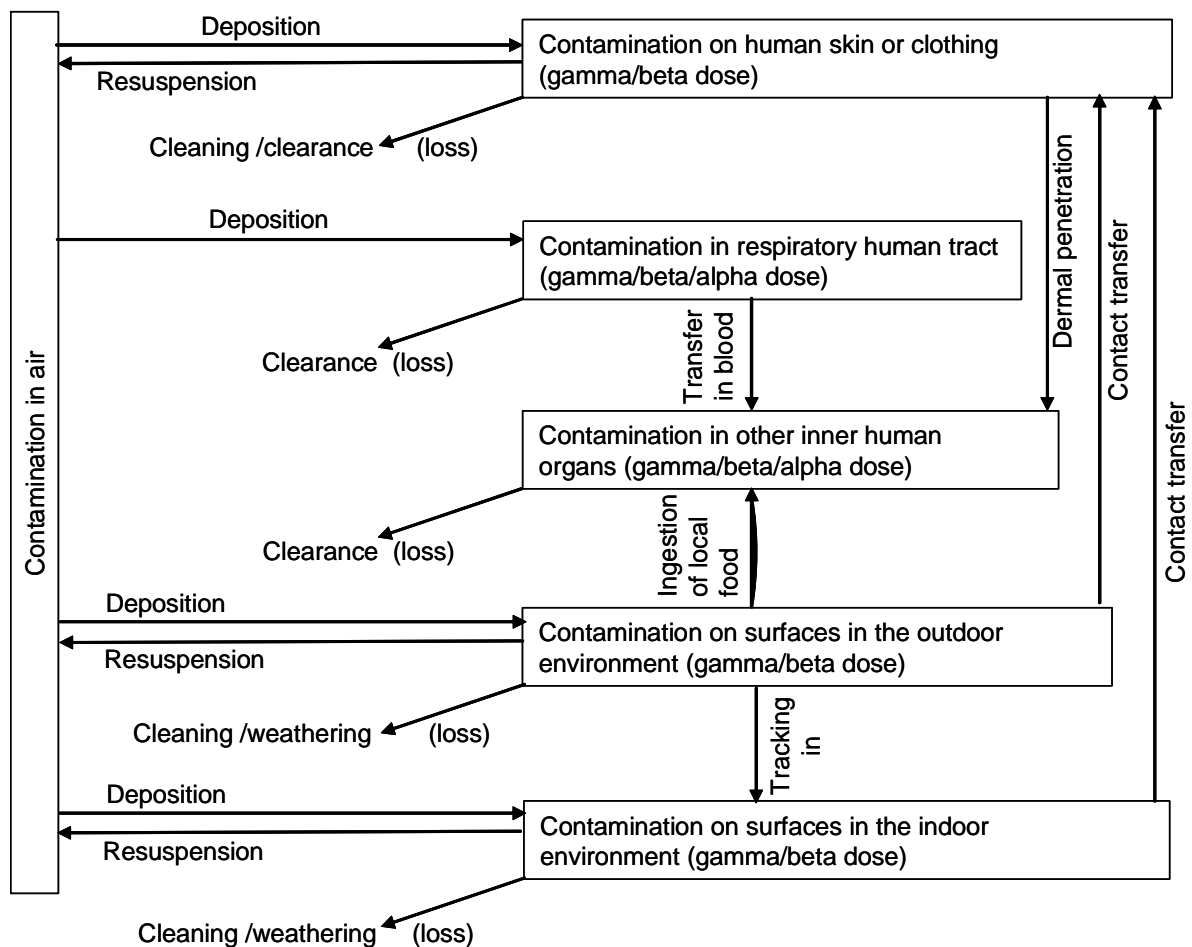

Figure 1. Potentially significant pathways of radionuclides in a residential area.

An important part of the handbook development has been a dialogue with end-user representatives in each of the Nordic countries, to focus the work on the specific needs of the user community. One of the instruments applied in this context was an exercise in the use of a prototype of the handbook, which gave valuable comments and directions that were followed up in the preparation of the final version.

In-line with the latest ICRP recommendations, a host of non-radiological factors are described in the URBHAND handbook. For instance, questions to consider in relation to social, ethical and communication factors in time before implementing any countermeasure strategy include:

- Has it been considered which direct costs the countermeasure implementation will have on society?
- Which indirect, economical, social, psychological and ethical problems could arise from countermeasure implementation, and which problems would be solved?
- How could the problems be addressed, with respect to re-establishment of societal functions and minimisation of penalties?
- Have adequate steps been made towards establishment of strategies for communication in an emergency, e.g., with the public and media?
- Have local assessments of risk perception been adequately considered in development of communication strategies?
- Do implementation plans contain sufficient level of stakeholder dialogue to avoid social disruption / problems?
- Is there risk that ethical key issues could be violated?
- Is the decision-making platform sufficiently matured to eliminate the risk of implements that could be seen as contradictory?
- Has it been ensured that affected persons are adequately informed of any additional risks that might arise and given a reasonable choice?
- Is the level of information given to operators sufficient to ensure optimal countermeasure implementation?
- Have practical methodological requirements been identified in local context, and has this knowledge been communicated out so that availability (also of technical support, e.g., for measurements) is secured prior to an emergency?

References

- Andersson, K.G., Roed, J. & Fogh, C.L. (2002). Weathering of radiocaesium contamination on urban streets, walls and roofs, *J. Environmental Radioactivity* vol. 62, no.1, pp. 49-60.
- Andersson, K.G., Ammann, M., Backe, S. & Rosén, K. (2008). Decision support handbook for recovery of contaminated inhabited areas. NKS report NKS-175, Nordic Nuclear Safety Research (NKS), Roskilde, Denmark, ISBN 978-87-7893-241-9.
- Andersson, K.G., Mikkelsen, T., Astrup, P., Thykier-Nielsen, S., Jacobsen, L.H., Schou-Jensen, L., Hoe, S.C. & Nielsen, S.P. (2008). Estimation of health hazards resulting from a radiological terrorist attack in a city, *Radiation Protection Dosimetry*, Vol. 131, No. 3, pp. 297-307.
- Andersson, K.G. & Roed, J. (2006). Estimation of doses received in a dry-contaminated living area in the Bryansk Region, Russia, since the Chernobyl accident, *J. Environmental Radioactivity*, vol. 85 (2-3), pp. 228-240.
- Brown, J., Mortimer, K., Andersson, K., Duranova, T., Mrskova, A., Hänninen, R., Ikäheimonen, T., Kirchner, G., Bertsch, V., Gally, F. & Reales, N. (2009). Generic handbook for assisting in the management of contaminated inhabited areas in Europe following a radiological emergency, parts I-V, Final report of the EC-EURANOS project activities CAT1RTD02 and CAT1RTD04, EURANOS(CAT1)-RP(07)-02, Radiation Protection Division, Health Protection Agency, UK.
- Fogh, C.L., Andersson, K.G., Barkovsky, A.N., Mishine, A.S., Ponamarjov, A.V., Ramzaev, V.P. & Roed, J. (1999). Decontamination in a Russian Settlement, *Health Physics* 76(4), pp. 421-430.
- Howard, B.J., Beresford, N.A., Nisbet, A., Cox, G., Oughton, D.H., Hunt, J., Alvarez, B., Andersson, K.G., Liland, A. & Voigt, G. (2005). The STRATEGY project: decision tools to aid sustainable restoration and long-term management of contaminated agricultural ecosystems", *J. Environmental Radioactivity*, vol. 83, pp. 275-295.

The final NKS report for the NKS-B URBHAND activity is available [here](#).

NKS-B LUCIA: Assessing the impact of releases of radionuclides into sewage systems in urban environment: Simulation, modelling and experimental studies

S., Sundell-Bergman¹, R. Avila², I. De la Cruz², S., Xu³, M., Puhakainen⁴, T., Heikkinen⁴, T.,
Rahola⁴, A., Hosseini⁵, S., Nielsen⁶ and M., Sigurgeirsson⁷

¹Vattenfall Power Consultant AB, Sweden

²Facilia AB, Sweden

³Swedish Radiation Safety Authority, Sweden

⁴STUK – Radiation and Nuclear Safety Authority, Finland

⁵Norwegian Radiation Protection Authority, Norway

⁶Risø-DTU National Laboratory, Denmark

⁷Geislavarnir Ríkisins, Iceland

Synnove.Sundell-Bergman@vattenfall.com

Introduction

This report summarises the findings of a project on assessing the impact of releases of radionuclides into sewage systems in urban environment - simulation, modelling and experimental studies- LUCIA. The project was partially financed by the Nordic nuclear safety research (NKS) in 2006 and 2007 and was established to provide more knowledge and suitable tools for emergency preparedness purposes in urban areas.

Wastewater that arises from dwellings, industries, universities and hospitals is transported through the sewer system to sewage treatment plants. These plants use biological and chemical precipitation methods to remove solid materials, as well as dissolved organic matter from the wastewater. Following treatment, effluents may be discharged to rivers or lakes in inland or to coastal waters. The remaining fraction, the sludge, is further dewatered at the plant and is mainly used as landfills at various sites since the heavy metal content has prevented its use as fertiliser for agricultural purposes.

The design of sewage treatment plants, and their wastewater treatments, is rather similar between the Nordic countries. The differences are mainly in their size, commonly measured by the number of person-equivalent served. The most exposed individuals for the releases of clinical radioactive waste from hospitals are usually to be found either at the sewage plant or in connection to the water recipients.

In this study one sewage plant in each of the five Nordic countries was selected for assessing the impact of radionuclide releases from hospitals into their sewerage systems. Measurements and model predictions of dose assessments to different potentially exposed members of the public were carried out. The models and approaches developed can also be applied in case of accidental releases.

Experimental Studies

One sewage plant per Nordic country has been chosen for this study. Information on all sewage treatment plants were acquired with the help of a questionnaire. Further information on hospital releases to those sewage treatment plants was also collated.

Measurements have been undertaken at those sewage works to determine the concentrations in sludge and water of clinically administered radionuclides. All measurements followed the same sampling protocol based on previous experiences in the field. Radionuclides measured included, but not the same set in all countries: ¹³¹I, ¹¹¹In, ^{99m}Tc, ¹⁷⁷Lu, ²¹⁴Pb, ²¹⁴Bi, ²⁰¹Tl, ⁷Be, ⁴⁰K, ¹³⁷Cs, ¹⁵³Sm.

Generic hospital data were also obtained, including radiopharmaceuticals administered to patients, activities and discharge rates that will enter the given wastewater sewage treatment plants. In some cases hospital data were also directly linked to the sampling programme in the sewage treatment plants.

All results from the sampling activities are presented in the report, per country, together with the influence of hospital inputs on the activity of incoming and outgoing water in the treatment plants. The removal of nuclides from the wastewater during the treatment process can then be estimated by comparing the radionuclides used in hospitals to those detected in the wastewater treatment plants.

A laboratory inter-comparison exercise was organised to compare analytical results across the laboratories participating in the project, using both ¹³¹I, dominating man-made radionuclide in sewage systems due to the medical use for diagnostic and therapeutic applications, and ¹¹¹In used for medical diagnostic purposes and

also commonly found in sewage systems. Overall, good agreement was found between participants for both sludge and water samples, but the agreement between laboratories for ^{131}I was slightly better than for ^{111}In .

Acquired data were used for verification of the simulations performed by the LUCIA model.

Application of Models

The modelling prediction tool for assessing the impact of liquid releases of radionuclides into the sewage systems is described. The prediction tool is based on the model LUCIA that has been modified for more generic applications.

The LUCIA model is a dynamic model. A dynamic approach is needed as equilibrium radionuclide concentrations may not exist within a sewage plant; due to the fact that radionuclides are not released continuously from hospitals during the whole year at a constant rate, but rather as pulses lasting few days.

The LUCIA model was initially developed for the sewage plant Kungsängsverket in Uppsala, but could be directly applied at Viikinmäki in Helsinki and Aalborg Renseanlæg Vest in Aalborg with their plant-specific parameter values. A simplified version of the LUCIA model was applied at Skólpa Klettagardar in Reykjavik, with no biological treatment being used. A modification of the model was necessary for Vestfjorden avløpselskap in Oslo, as it uses a different type of biological treatment.

The LUCIA mathematical model consists of a system of ordinary differential equations (ODE). These represent the mass balance in the different compartments. These allow estimating the concentration of radionuclides in water and sludge depending on the radionuclide concentration in the plant inlet. The model was implemented using the software package Ecolego (from Facilia AB).

Parameters relating to the treatment processes are derived from data measured in the studied sewage plants. Although an extensive literature review was carried out, distribution coefficients for sludge were not found for any of the elements of interest. Instead, K_d values reported for organic soils were used, which to some extent can be considered as representative for sewage sludge, consisting mainly of organic material.

The sensitivity of the model to variation in the model parameters was studied using the software package Eikos (From Facilia AB). The sensitivity study was carried out for ^{131}I , which is one of the significant radionuclides for the exposure of sewage workers. The LUCIA conceptual model is shown schematically below and the series of assumptions are described in the final report.

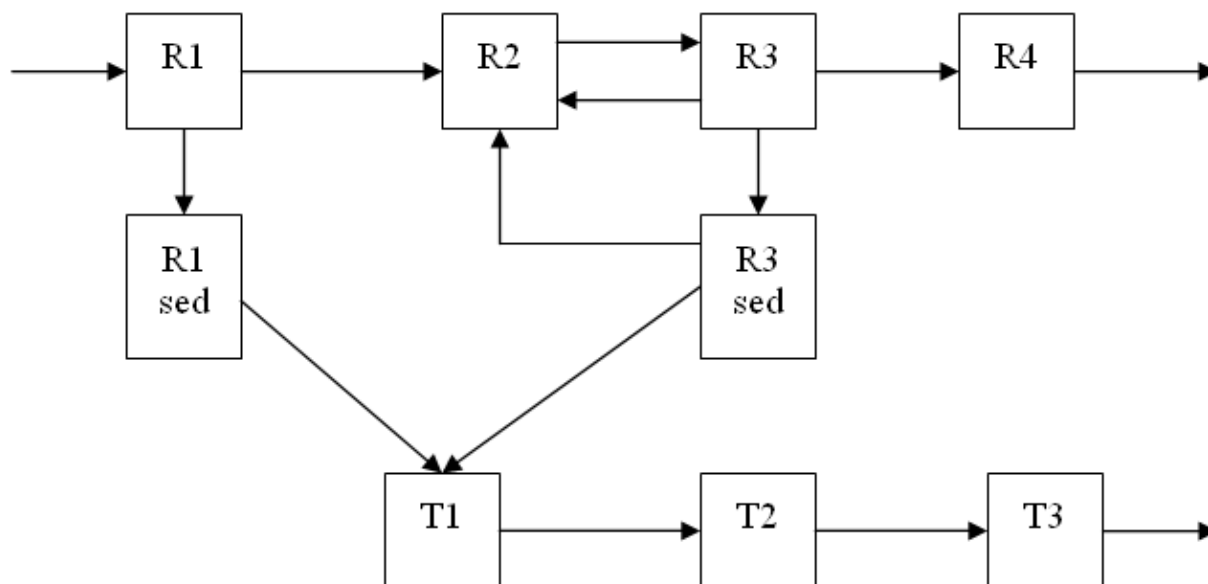

Figure 1. Conceptual representation of the LUCIA model for the Uppsala sewage plant. Each box represents a model compartment that is associated with a plant component and the arrows to radionuclide fluxes between compartments. R1: Primary sedimentation basins - water phase; R1sed: Primary sedimentation basins - precipitated sludge; R2: Basins for biological treatment; R3: Secondary sedimentation basins - water phase; R3sed: Secondary sedimentation basins - precipitated sludge; R4: Sedimentation basin for final polishing - water phase; T1: Thickener, sink and silo; T2: Digester; T3: Centrifuge and sludge storage.

A process oriented model of the biological treatment is also proposed in the report that does not require as much input data as for the LUCIA model. This model is a combination of a simplified well known Activated Sludge Model No.1 (Henze, 1987) and the Kd concept used in the LUCIA model. The simplified model is able to estimate the concentrations and the retention time of the sludge in different parts of the treatment plant, which in turn, can be used as a tool for the dose assessment purpose.

Dose assessments

Doses resulting from routine releases of ^{99m}Tc and ^{131}I from hospitals into each of the study sewage plants were calculated. The doses were calculated for hypothetical individuals representing potentially three exposed members of the public, including: i) sewage workers, ii) individuals potentially exposed to the water released from the sewage plants and iii) individuals potentially exposed to contaminated sewage sludge that is used for fertilization of agricultural lands. The annual release rates of radionuclides were used as inputs to the LUCIA model, for calculating radionuclide concentrations in water and sludge. The calculations of radionuclide concentrations and doses were performed using the software-package Ecolego. All models, and chosen parameters, are described in the report, highlighting pathways that each potentially exposed members of the public may be exposed. The resulting radionuclide concentration values in discharge water and sewage sludge are reported for each studied sewage treatment plant. The predicted differences between the plants are within one order of magnitude and reflect the differences in the release rates applied.

For hypothetical individuals who may drink water and ingest fish contaminated by sewage water, predicted values of annual dose rates are conservative as estimates do not take into account the dilution of the waters discharged from the plant in the final recipient. Estimated doses, for all studied plants, are well below 10 $\mu\text{Sv/a}$ for ^{99m}Tc , which is a commonly accepted exemption level (EU). For ^{131}I doses above the exemption levels are obtained, if dilution in the final recipient is not taken into account.

For hypothetical sewage workers, predicted values of annual dose rates are conservative, as it is assumed that exposure occurs during the whole working day, i.e. 8 hours every working day. The best estimates of the doses were insignificant, below 10 $\mu\text{Sv/a}$, for both ^{99m}Tc and ^{131}I in all studied plants. If uncertainties in the prediction of activity concentrations in sludge are considered, then the probability of obtaining doses above 10 $\mu\text{Sv/a}$ may not be insignificant. It can therefore be concluded that doses to sewage workers require a more realistic and case by case consideration.

For hypothetical farmers that use sewage sludge for fertilization of agricultural lands, predicted values of annual dose rates for both studied radionuclides and all sewage plants, were well below the commonly accepted exemption level of 10 $\mu\text{Sv/a}$. The doses were also much lower than the doses to the sewage workers and doses to individuals by water pathways.

Conclusion

The studied sewage treatment plants and associated treatment processes are quite similar in the five Nordic countries. In addition handling of liquid radioactive waste from hospitals carrying out nuclear medical treatment is comparable between the five countries. Information on all plants was collated and measurements carried out in those sewage treatment plants as well as in hospital discharges that will input into the plants. Data acquired was used as input to the models used to calculate doses to hypothetical members of the public. Doses from radionuclides that are routinely released from hospitals into sewage systems have been estimated for selected plants in all Nordic countries, using the LUCIA model implemented in Ecolego.

The results indicate that in case of routine releases annual doses to the three hypothetical groups of individuals are most likely insignificant. Estimated doses for workers are below 10 $\mu\text{Sv/y}$, for the two studied radionuclides ^{99m}Tc and ^{131}I . If uncertainties in the predictions of activity concentrations in sludge are considered, then the probability of obtaining doses above 10 $\mu\text{Sv/y}$ may not be insignificant. Also, doses associated with usage of sewage sludge, such as farmer using sludge for fertilization, are lower than doses to individuals affected by water pathways. The models and approaches developed in this project can be applied for accidental releases. In case of accidental releases to sewage plants, it is important to take into account the dynamics in the variation of the activity concentrations in the sewage water and sludge. This would allow more properly estimation of the time variation of the doses and identification of the people that can be affected.

The final NKS report for the NKS-B LUCIA activity is available [here](#).

Title	Proceedings of the NKS-R and NKS-B Joint Summary Seminar
Author(s)	J. P. Gwynn and P. Isaksson (Editors)
Affiliation(s)	NKS
ISBN	978-87-7893-269-3
Date	August 2009
Project	NA
No. of pages	79
No. of tables	11
No. of illustrations	37
No. of references	124
Abstract	<p>Nordic Nuclear Safety Research (NKS) is a platform for Nordic cooperation and competence in nuclear safety and related radiation protection issues including emergency preparedness and protection of the environment. Its purpose is to carry out joint activities producing seminars, exercises, scientific articles, technical reports and other types of reference material, with special efforts made to engage young scientists.</p> <p>The region in question is the five Nordic countries, i.e., Denmark (including the Faroe Islands and Greenland), Finland, Iceland, Norway and Sweden, who share a common cultural and historic heritage. The Nordic countries have cooperated in the field of nuclear safety for approximately half a century, developing informal networks for exchange of information, strengthening the region's potential for fast, coordinated and adequate response to nuclear threats, incidents and accidents. Activities are financed and supported by Nordic authorities, research institutions, power companies, contractors and other organizations, with results used by participating organizations in their decision making processes and information efforts. The NKS-R and NKS-B Joint Summary Seminar held at the Armémuseum, Stockholm on the 26th - 27th of March 2009 showcased a range of activities supported by NKS over the previous 2 years and provided an opportunity to bring together researchers and end users from the wider NKS community. This summary seminar was the first joint venture between the NKS-R and NKS-B Programmes since the current two programme format was adopted by NKS. One of our intentions in organising the Joint Summary Seminar was to further the reciprocal awareness of ongoing research and issues under the respective NKS-R and NKS-B Programmes, with the aim of promoting new networking opportunities and generating new ideas and approaches to solving existing problems.</p>
Key words	NKS, NKS-B, NKS-R, Nordic nuclear safety