

Technical University of Denmark



Assessing the impact of releases of radionuclides into sewage systems in urban environment - simulation, modelling and experimental studies - LUCIA

Sundell-Bergman, Synnöve; Avila, Rodolfo; de la Cruz, Idalmis; Xu, Shulan; Puhakainen, Marketta; Heikkinene, Tarja; Rahola, Tua; Hosseini, Ali; Nielsen, Sven Poul; Sigurgeirsson, Magnus

Publication date:
2009

Document Version
Publisher's PDF, also known as Version of record

[Link back to DTU Orbit](#)

Citation (APA):
Sundell-Bergman, S., Avila, R., de la Cruz, I., Xu, S., Puhakainen, M., Heikkinene, T., ... Sigurgeirsson, M. (2009). Assessing the impact of releases of radionuclides into sewage systems in urban environment - simulation, modelling and experimental studies - LUCIA. Roskilde: Nordisk Kernesikkerhedsforskning. (NKS-192).

DTU Library
Technical Information Center of Denmark

General rights

Copyright and moral rights for the publications made accessible in the public portal are retained by the authors and/or other copyright owners and it is a condition of accessing publications that users recognise and abide by the legal requirements associated with these rights.

- Users may download and print one copy of any publication from the public portal for the purpose of private study or research.
- You may not further distribute the material or use it for any profit-making activity or commercial gain
- You may freely distribute the URL identifying the publication in the public portal

If you believe that this document breaches copyright please contact us providing details, and we will remove access to the work immediately and investigate your claim.



Nordisk kernesikkerhedsforskning
Norrænar kjarnöryggisrannsóknir
Pohjoismainen ydinturvallisuustutkimus
Nordisk kjernesikkerhetsforskning
Nordisk kärnsäkerhetsforskning
Nordic nuclear safety research

NKS-192
ISBN 978-87-7893-259-4

Assessing the impact of releases of radionuclides into sewage systems in urban environment - simulation, modelling and experimental studies – LUCIA

Synnöve Sundell-Bergman¹, Rodolfo Avila², Idalmis de la Cruz², Shulan Xu³, Marketta Puhakainen⁴, Tarja Heikkinene⁴, Tua Rahola⁴, Ali Hosseini⁵, Sven Nielsen⁶ and Magnus Sigurgeirsson⁷

¹Vattenfall Power Consultant, Sweden

²Facilia AB, Sweden

³Swedish Radiation Safety Authority, Sweden

⁴STUK, Finland

⁵Norwegian Radiation Protection Authority, Norway

⁶Risø National Laboratory for Sustainable Energy, DTU, Denmark

⁷Geislavarnir ríkisins, Iceland

June 2009

Abstract

This report summarises the findings of a project on assessing the impact of releases of radionuclides into sewage systems and was established to provide more knowledge and suitable tools for emergency preparedness purposes in urban areas. It was known that the design of sewage plants, and their wastewater treatments, is rather similar between the Nordic countries. One sewage plant in each of the five Nordic countries was selected for assessing the impact of radionuclide releases from hospitals into their sewerage systems. Measurements and model predictions of dose assessments to different potentially exposed members of the public were carried out. The results from the dose assessments indicate that in case of routine releases annual doses to the three hypothetical groups of individuals are most likely insignificant. Estimated doses for workers are below 10 $\mu\text{Sv/y}$, for the two studied radionuclides $^{99\text{m}}\text{Tc}$ and ^{131}I . If uncertainties in the predictions of activity concentrations in sludge are considered, then the probability of obtaining doses above 10 $\mu\text{Sv/y}$ may not be insignificant. The models and approaches developed can also be applied in case of accidental releases.

A laboratory inter-comparison exercise was also organised to compare analytical results across the laboratories participating in the project, using both ^{131}I , dominating man-made radionuclide in sewage systems due to the medical use. A process oriented model of the biological treatment is also proposed in the report that does not require as much input data as for the LUCIA model. This model is a combination of a simplified well known Activated Sludge Model No.1 (Henze, 1987) and the K_d concept used in the LUCIA model. The simplified model is able to estimate the concentrations and the retention time of the sludge in different parts of the treatment plant, which in turn, can be used as a tool for the dose assessment purpose. filled by the activity.

Key words

risk assessment, sewage sludge, radioactive iodine, Tc-99m, dose modelling

NKS-192
ISBN 978-87-7893-259-4

Electronic report, June 2009

NKS Secretariat
NKS-776
P.O. Box 49
DK - 4000 Roskilde, Denmark

Phone +45 4677 4045
Fax +45 4677 4046
www.nks.org
e-mail nks@nks.org

Assessing the impact of releases of radionuclides into sewage systems in urban environment - simulation, modelling and experimental studies - LUCIA

Sundell-Bergman Synnöve

Vattenfall Power Consultant, P.O. Box 527, SE 162 87 Stockholm, Sweden

Avila Rodolfo, de la Cruz Idalmis

Facilia AB, Gustavlundsv 151C, SE-167 51 Bromma, Sweden

Xu Shulan

Swedish Radiation Safety Authority, SE_171 16 Stockholm, Sweden

Puhakainen Marketta, Heikkinen Tarja, Rahola Tua

STUK - Radiation and Nuclear Safety Authority, P.O. Box 14, FIN - 00881 Helsinki, Finland

Hosseini Ali

Norwegian Radiation protection Authority, Grini næringspark 13, 1361 Østerås, Norway

Nielsen Sven

Risø National Laboratory for Sustainable Energy, Technical University of Denmark, P.O. Box 49, DK-4000 Roskilde, Denmark

Sigurgeirsson Magnus

Geislavarnir Ríkisins, Raudararstigur 10, 150 Reykjavík, Iceland

**NKS Project LUCIA
NKS AFT/B(06)7**

Foreword

In this report the generation of liquid radioactive waste and its disposal from hospitals is considered. Measurements have been undertaken at various sewage works to determine the concentration in sludge and water of clinically administered radionuclides. The modelling prediction tool for assessing the impact of liquid releases of radionuclides into the sewage systems is described. The prediction tool is based on the model LUCIA that has been modified for more generic applications. The project, partially financed by the Nordic Nuclear Safety Research (NKS) in 2006 and 2007, was also established to provide more knowledge and suitable tools for emergency preparedness purposes in urban areas.

The treatment processes of the sewage plants in the Nordic countries are quite similar. Also the handling of liquid radioactive waste from hospitals carrying out nuclear medical treatment is comparable.

The authors acknowledge the financial and intellectual support from NKS.

NKS conveys its gratitude to all organizations and persons who by means of financial support or contributions in kind have made the work presented in this report possible.

Table of contents

Foreword	2
1.	Introduction..... 5
2.	Background..... 5
3.	General description of the wastewater treatment process..... 6
4.	Information about the selected sewage plants in the study..... 8
5	Protocol for sampling at sewage works and for measurements of ¹³¹ I-iodine 10
5.1	Introduction..... 10
5.2	Measurement protocol 10
6	Sampling and measurements at sewage plants in the Nordic Countries..... 11
Finland	11
6.1	Introduction..... 11
6.2	Materials and Methods..... 12
6.2.1	Hospitals 12
6.2.2	Wastewater treatment plant 12
6.2.3	Fucus vesiculosus sample 13
6.2.4	Measurements 13
6.3	Results..... 14
6.3.1	Air sampling 17
6.3.2	Fucus samples 18
Sweden	18
6.4	Introduction..... 18
6.5	Methods 19
6.6	Results..... 20
6.7	Measurements of ¹⁷⁷ Lu releases from the Uppsala University Hospital..... 22
Norway	23
6.8	Introduction..... 23
6.9	Methods 23
6.10	Water samples..... 24
6.11	Sludge samples 24
6.12	TLD measurements..... 24
6.13	Results and Discussion 25
Denmark	28
6.14	Introduction..... 28
6.15	Materials and methods..... 28
6.16	Results..... 29
Iceland	31
6.17	Summary 31
7.	Intercalibration..... 33
7.1	Introduction..... 33
7.2	Samples..... 33
7.3	Participants 33
7.4	Results..... 34
7.5	Conclusions..... 36
8	The Lucia model 36
8.1	The conceptual model..... 37
8.1	Assumptions 37
8.2	Mathematical model and parameters 40
8.3	Sensitivity analysis 40
9	A modelling study using process orientated activated sludge model 41
9.1	Introduction..... 41
9.2	Proposed models 41

9.2.1	Simplified activated sludge model.....	41
9.2.2	K_d concept.....	43
9.2.3	Wastewater compositions	43
9.2.4	Sedimentation processes	44
9.2.5	Simulation results	44
9.3	Summary	49
10	Dose assessments	50
10.1	Pathways	50
10.2	Parameter values	54
10.3	Results of the dose calculations	57
10.4	Conclusions from dose assessments	61
	References	62

1. Introduction

In urban areas the wastewater from industries, households, hospitals and other institutions is transported through the common municipal sewage systems to the wastewater treatment plant. Also the run-off water from particular geographical areas is transported via the same pathways to the plant for treatment. It could be argued that the sewage system in urban environment functions as a kidney in order to filtrate disposed contaminants in sewage. Several investigations have confirmed the suitability of sewage sludge as an indicator of organically bound agents such as heavy metals, chemical contaminants and pharmaceuticals. Higher concentrations of water-soluble pharmaceuticals have also been detected in the recipient close to the sewage plant, indicating the key function of the sewer as a kidney. The high content of specifically heavy metals has limited the use of sludge as fertiliser in agriculture. Today, sludge is often used as road filling, deposit coverage, fertiliser for golf courses, etc., where the health impact is judged to be minimal.

The bulk of radioactive material arising from patients undergoing treatment in hospitals will be discharged through the sewage works. With few notable exceptions, most of the radionuclides released due to medical treatment have in general very short half-lives with low radiological impact. However, one of the more important exceptions is radioactive iodine which is used in the treatment of cancer and other diseases of the thyroid. Also radionuclides like ^{111}In or ^{177}Lu , frequently used at some hospitals, can easily be detected at the corresponding sewage works.

Atmospheric releases of radionuclides from nuclear power stations may, after ground dry deposition, be transported by the runoff water to the sewage treatment plants (Ingemansson et al., 1981). Erlandsson et al (1978) have also demonstrated that atmospheric releases of radionuclides from nuclear weapon tests occurring very distant from the sewage plant could be detected in sewage sludge. Thus, the sewage sludge is a sensitive indicator for both direct releases to the sewer systems as well as to the air.

Previous studies of the behaviour of radionuclides in municipal sewage treatment systems have been focused on the radiation exposure of the public. In conjunction, the assessments that have been performed have overall been highly generic and not considering the kinetics in the sewage system as well as doses to sewage workers. It should be emphasised, that the calculation of the impact from radionuclides released from hospitals is difficult, because the releases from hospitals are often unknown. In addition, the releases are occasional and irregular which exacerbates correlations between assessments and measurements. On the basis of these circumstances and the increasing amount of nuclear medical treatments, it is of importance to develop dynamic assessment tools to predict the radiological impact of such releases.

From a regulatory perspective it is important to have a firm understanding of the radiological consequences from routine releases to sewer systems from several licensees. It is also essential to explore the key function of the sewage plant in case of radiological emergencies and to have suitable risk assessments tools ready for use. This project was undertaken to further develop the LUCIA code that models the radionuclide behaviour in sewers, in order to also be applicable for various accidental situations. The aim was to further generalise the LUCIA code for all partners involved in the project.

2. Background

Wastewater arises from dwellings, industries, universities and hospitals and is transported through the sewer system to the wastewater plant. These plants use biological and chemical precipitation methods to remove solid materials, as well as dissolved organic matter from the wastewater. Following treatment, effluents may be discharged to rivers or lakes in inland or to coastal waters. The remaining fraction, the sludge, is further dewatered at the plant and several studies have shown that sewage

sludge is a sensitive indicator of radionuclides, either released from hospitals or spread via the atmosphere (Puhakainen 1998, Erlandsson and Mattsson 1978).

The design of sewage plants is rather similar between the Nordic countries and also comparable wastewater treatments are carried out at the plants in question. The differences are mainly in their size, commonly measured by the number of person-equivalent served. In short; the sludge is removed from the wastewater in two consecutive steps and conveyed to a thickener where the volume is reduced. This process leads to a corresponding increase of the radionuclide concentration if it is organically bound, but the residence time of a sludge particle is only about one day. The overall retention time of a particle in the sludge process is about 20 days. Hence a substantial reduction of the activity of short-lived radionuclides including iodine, will take place. The digested sludge is mainly used as landfills at various sites since the heavy metal content has prevented its use as fertiliser for agricultural purposes. Subsequently, the most exposed individuals for the releases of clinical radioactive waste are usually to be found either at the sewage plant or in connection to the water recipients.

In case of releases from nuclear energy production or through malicious acts, other types, more long lived, of radionuclides have to be considered in the risk assessments like e.g. ^{137}Cs or ^{90}Sr . The fate of contaminated sludge is thus of prime concern and needs to be evaluated.

3. General description of the wastewater treatment process

The purpose of the sewage effluent treatment is to clean the effluents before discharging into the environment. Pollutants which are removed include larger inorganic and organic solids (floating items), suspended solids (particles larger than 0.45 micrometer, very fine particles) dissolved oxygen consumption matter (organic substances), phosphorous and nitrogen.

The load of pollutants varies during the season of the year and within the day. Stormy weather can also influence the fluxes of water and pollutants to the sewage plant. Although the wastewater and storm water are commonly transported in different pipe systems, there exist leakages in the system, which explains why heavy rains can affect the fluxes of wastewater into the sewage plant.

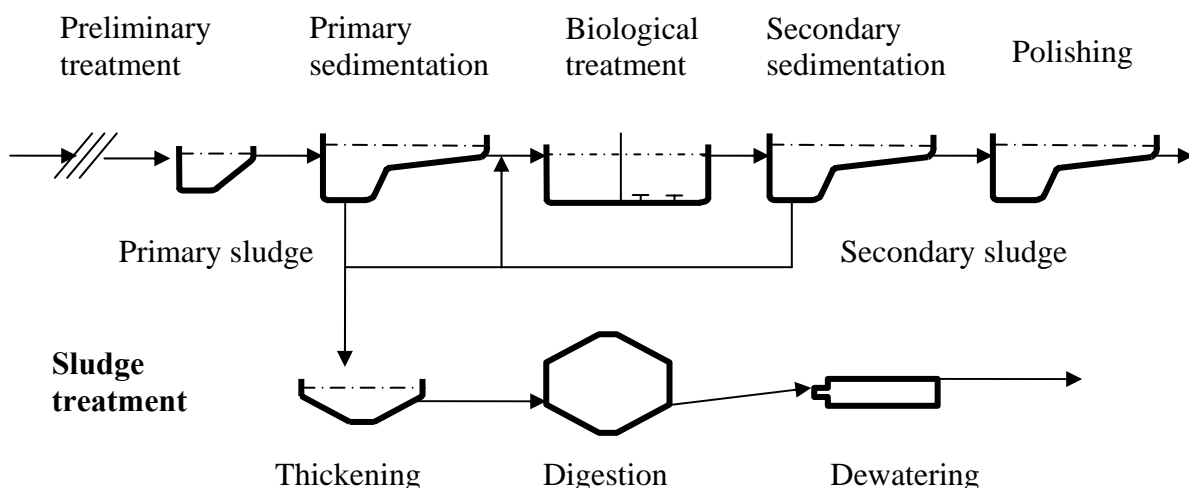

Figure 1. Schematic representation of the waste water treatment at sewage plants

In the Nordic countries the processes of wastewater treatment are relatively similar between the plants as well as the design of the sewage works. The main difference is the size, commonly measured by the number of persons-equivalent¹ served. The final recipient of the effluents may either be a river, a lake or coastal waters.

Effluent treatment (see Fig. 1), includes mechanical, biological and chemical processes for cleaning the wastewater, while the sludge treatment aims mainly at stabilising the generated sludge and reducing its volume.

a) Preliminary treatment

The purpose of the preliminary treatment is to remove large pieces of material by screening and rapid sedimentation. The process is continuous and fast. Radionuclides and other contaminants absorbed onto the removed materials will be extracted from the effluent. This preliminary treatment does not significantly affect the suspended solid load and will therefore have a small effect on the overall radionuclide concentration in the effluent (Tittley *et al.* 2000).

b) Primary Sedimentation

During primary sedimentation the suspended particles are settled by gravity under quiescent conditions in large settling tanks. Settling with coagulation and flocculation may remove 60 to 90 % of the suspended solids and 30-60 % of the chemical oxygen demand (COD). Adding of chemical substances for flocculation also withdraws phosphorous from the incoming wastewater. The residence time of water in the primary sedimentation tanks is only a few hours, but can be sufficient to reduce significantly the activity of radionuclides with very short half lives such as ^{99m}Tc.

b) Biological treatment

The effluent is pumped into basins for biological treatment, which predominantly is an aerobic process using high concentrations of micro-organisms to convert the biodegradable organic matter (BOD and COD) into carbon dioxide (35-45 %) and increase the solid content (45-55 %).

The residence time for the treatments is several hours, which is sufficient to significantly reduce the activity of radionuclides with very short half lives such as ^{99m}Tc. During the treatment the concentration of solids in the wastewater is about ten times higher than in the incoming wastewater, which can favour the sorption of radionuclides to solids which are subsequently removed during the secondary sedimentation step.

c) Secondary sedimentation

Solids (biomass) remaining in the effluent after the biological treatment are removed by settling. The micro-organisms used in the biological treatment have a relatively low growth rate. To keep the concentrations of micro-organisms at the necessary level, about 40-50% of the sludge is thus pumped back to the biological treatment. Although this is a short duration process, the sludge recycling may imply that a particle bound radionuclide can decay considerably before the secondary sludge is removed for further treatment.

d) Polishing step

In the last polishing step the remaining suspended solids, organic matter and nutrient phosphorus are removed. A small quantity of precipitation chemicals is often used to promote flocculation and thereby

¹ The number of persons-equivalent measures indirectly the waste water flux coming into the sewage plant, including domestic and industrial waste water.

enhance the removal of phosphorous. The sludge is then usually pumped back to the primary sedimentation process. This process has a small influence on the overall concentration of radionuclides in the wastewater.

The retention time of a water particle in the plant is typically 15-30 hours. However, there are plants with less retention time due to high water flow in relation to the basin volumes.

e) *Sludge treatment*

Sludge removed in the effluent treatment process is conveyed to a thickener to proportionally increase the solid concentration. This leads to a corresponding increase of the radionuclide concentrations in the sludge. The residence time of a sludge particle in the process is around one day.

In the digestion chamber the sludge is stabilised by decomposition of organic matter to reduce odour and pathogens. The retention time in the digester is typically 20 days and hence there will be a substantial reduction of the activity of short live radionuclides. Releases to air of ¹⁴C and volatile radionuclides, such as ¹³¹I can take place at this stage.

After that, the sludge can be dewatered by physical processes such as air drying or centrifugation, reaching a solid concentration of normally about 25 % .The final use of digested sludge determines which procedure will be adopted.

The overall retention time of a particle in the sludge treatment is typically 20-30 days. In plants with nitrogen removal the retention time is longer than in plants without this process.

4. Information about the selected sewage plants in the study

A questionnaire was sent out to the participants for gathering information about the treatment process at the selected sewage works (see Table 1).

Table 1. Information about the sewage plants used in the study

Requested information	Sweden	Finland	Norway	Denmark	Iceland
Name of plant	Kungsängverket	Viikinmäki	VEAS Vestfjorden avløpsselskap	Renseanlaeg Vest	Skólpa Klettagardar
Geographic location	Uppsala	Helsinki	Outside Oslo	Aalborg	Reykjavik
Hospitals ² served by the plant	Academic hospital	Central University Hospital Maria Diacor	Riks-Radium hospitalet Ullevål,	Aalborg sygehus Sygehus Nord	Landspítali University hospital
Recipient for wastewater	Fyrisån	Baltic sea	Oslo fjord	Limfjorden	5,5 km off the shore
Water treatment ³	Mechanical and chemical flocculation	Screening, separation and chemical flocculation	Chemical flocculation and settling	Chemical flocculation and settling	Filtration and settling
Activated sludge treatment (AST) ⁴ and attached growth	Aerobic, surface treatment	Aerobic, biological secondary filtration	Aerobic, surface treatment with microbial	Aerobic, surface treatment with microbial	No treatment

² Hospitals with nuclear medical department

³ Water treatment normally involves mechanical treatment and chemical flocculation; N for normal.

⁴ Aerobic process using normally high concentrations of microorganisms.

Requested information	Sweden	Finland	Norway	Denmark	Iceland
treatment (AGT) ⁵					
Sludge treatment	Digestion and centrifugation	Digestion and centrifugation	Digestion and vacuum drying	Digestion and centrifugation	No treatment
Number of equivalent persons/year	180000	740000	440000	200000	46000
Water flux (m ³ /day)	46045	260000	300000	80000	85000
Sludge (kg dw/day)	9000	60000 ⁶	29000	8500	1300
⁷ In; Suspended solids (kg dw/m ³)	0,2	0,31	2027 ⁸	0.2	0,08
In; COD (kg dw/m ³)	0,5	0,52	454 ⁹	0.3	0,12
¹⁰ Out; Suspended solids (kg dw/m ³)	0,006	0,004	5 ¹¹	0.004	0,08
Out; COD (kg dw/m ³)	0,05	0,04	41	0.02	0,12
¹² Mech; Suspended solids (kg dw/m ³)	0,08	0,15	Na ¹³	1.5	0,08
Mech; COD (kg dw/m ³)	0,2	0,30	Na ¹⁴	0.4	0,12
¹⁵ Biol; COD (kg dw/m ³)	0,05	0,048	Na ¹⁶	0,05	-
Biol; Suspended solids (kg dw/m ³)	0,006	0,011	Na ¹⁷	4	-
Basins volumes , m ³ (mech) ¹⁸	6800	34846	17500	7600	3500
Basin volumes m ³ (boil) ¹⁹	58000	92000	550	39480	-
Residence time of water in the plant (h)	30	22	3	48	0,6
²⁰ Mech; Residence time, water (h)	3	3,4	Na ²¹	4,5	0,5

⁵ Provides a surface on which microbial layer can grow.

⁶ After digestion

⁷ Incoming to plant

⁸ mg/l

⁹ mg/l

¹⁰ Outgoing from plant

¹¹ mg/l

¹² After first mechanical treatment

¹³ Not available

¹⁴ Not available

¹⁵ After biological treatment

¹⁶ Not available

¹⁷ Not available

¹⁸ Basins for primary sedimentation (mechanical treatment)

¹⁹ Basins for mechanical treatment

²⁰ Residence time for water particle in the mechanical treatment

²¹ Not available

Requested information	Sweden	Finland	Norway	Denmark	Iceland
²² Biol; Residence time, water (h)	25	7,9	Na ²³	23,5	-
²⁴ Residence time, sludge (days)	20	21	20	22	-
Flux, primary ²⁵ (kg dw/day)	13000	60000	Na ²⁶	150(5%)	1300
Flux, secondary ²⁷ (kg dw/day)	3900	40000	Na ²⁸	549 (5%)	-

The treatment process was rather similar in the Swedish (Kungsängsverket), Finnish (Vikinmäki) and Danish (Renseanlaeg Vest) plants while the process was more complicated in Norwegian plant. The Icelandic sewage work has a rather simple process with no biological treatment.

5 Protocol for sampling at sewage works and for measurements of ¹³¹I-iodine

5.1 Introduction

The partners of the LUCIA project carried out measurements of the radioactive substances entering the sewage works. For that purpose a measurement protocol was established based on previous experiences in this field (see Fig 2). The acquired data were later to be used for verification of the simulations performed by the LUCIA model.

5.2 Measurement protocol

5. *Information about the releases*

The activity administered to patients was registered at the beginning of the measurement period, together with the date and the time. Also the types of treatment as well as the delivered radiopharmaceuticals were registered.

6. *Measurements in water*

Twenty-four hour composite samples of incoming and outgoing water were collected in 1-litre bottles at the sewage plant. The samples were then stored in cold until analysis. Samples were taken during ten consecutive days beginning 3 days before the anticipated release. The water fluxes at the plant during the sampling period were registered during the sampling period.

7. *Measurement of sludge*

Samples of the wet sludge were taken once a day during the sampling period for ten consecutive days beginning 3 days before the anticipated release. Samples of digested sludge were taken less frequent and dependent on the applied treatment process of the plant in question.

8. *Sample preparation*

²² Residence time for water particle in biological treatment

²³ Not available

²⁴ Residence time of sludge particle in sludge treatment

²⁵ Flux of primary sludge

²⁶ Not available

²⁷ Flux of sludge after biological treatment

²⁸ Not available

The samples were dried at 105°C and then homogenized before measurement. Occasionally samples were measured directly after sampling and the solid content was determined. Alternatively, the samples were filtered and both the filtrate and the precipitate were then measured.

9. Measurements

The activity of samples were spectrometrically determined commonly using Ge(Li) or high purity germanium detectors.

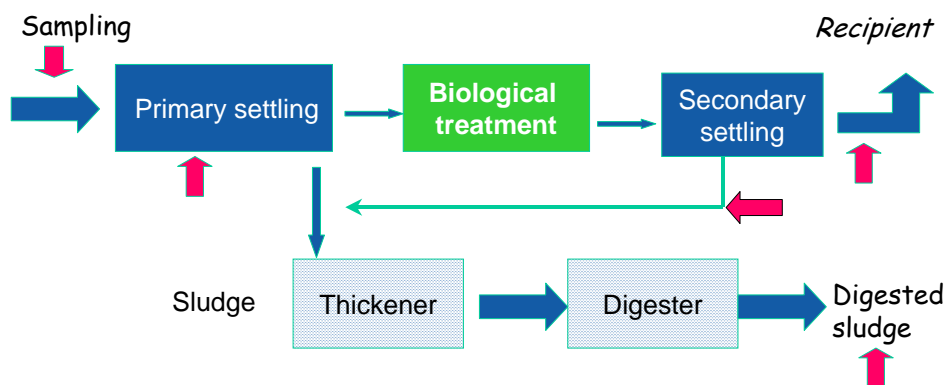

Figure 2. Schematic view of the sewage plant showing where the samples usually were taken out for measurements

6 Sampling and measurements at sewage plants in the Nordic Countries

Finland

6.1 Introduction

For the LUCIA project samples from the Viikinmäki wastewater treatment plant in Helsinki were taken during two years. The activity concentrations ^{131}I originating from therapeutic procedures in hospitals were measured in water and sludge from the wastewater treatment plant. Twenty four hour composite samples from incoming and outgoing waste water and spot samples from primary and dried digested sludge were collected during two weeks in 2006. To estimate the potential risks from potential ^{131}I -release to the air, air samples were also taken. Two air samples were collected from the discharge air in a pipe. Also two *Fucus vesiculosus* samples were collected in the sea area near Helsinki for gamma spectrometric measurements.

In 2003 the number of nuclear medicine examinations in Finland was 45 000 and the number of therapeutic treatments was 2 300. The number of treatments of thyrotoxicosis was about 1 300 and of thyroid carcinoma about 520 (Korpela 2005). In 2003 the total activity of ^{131}I used for diagnostic nuclear medicine procedures was 175 GBq and for therapeutic procedures 2560 GBq. The ^{131}I activity administered to the patients for the treatment of thyrotoxicosis is generally in the range of 185 – 550 MBq and for thyroid carcinoma in the range of 2 700 – 5 500 MBq. The regulations in Finland require that before a patient is discharged from the hospital following ^{131}I therapy it must be verified that the residual activity in the patient does not exceed 800 MBq (STUK, Guide ST 6.3, 2003). The discharge limits for radioactive substances are given by STUK. The maximum activity of ^{131}I that can be discharged into a sewer system

on one occasion is 2 MBq and 20 MBq per month (STUK, Guide ST 6.2, 1999). However, the discharge limits do not apply to the excreta of patients receiving radioactive substances in medical use of radiation.

Table 2. Radiopharmaceuticals administered to patients in Finland for therapeutic purposes in 2006

Radiopharmaceutical	Application	Administered activity, per patient		laboratory	Number
		mean, MBq	range MBq		
¹³¹ I-iodide	thyrotoxicosis	367	185-555	23	1191
¹³¹ I-iodide	thyroid carcinoma	3816	2700-5500	19	417
³² P-phosphate	blood disease	144	111-185	20	313
⁹⁰ Y-citrate	joint	220		1	3
⁹⁰ Y Zevalin	cancer metastases	1173	920-1596	6	8
¹⁵³ Sm EDTMP	bone metastases	2956	2040-3000	3	22

6.2 Materials and Methods

6.2.1 Hospitals

Hospitals that use radionuclides in the study area are the Helsinki University Central Hospital (HUCH), and the Maria Hospital. Of the cancer therapies using ¹³¹I in Finland, 21% are carried out by the Helsinki University Central Hospital. Of all ¹³¹I used for therapeutic purposes in 2006, 15% were used in these two hospitals. All excreta of therapy patients in the hospital are flushed into the sewage system without any storage. The treatments of thyrotoxicosis are usually carried out on Fridays similar to the treatments of thyroid carcinoma. Therefore, the highest activity concentrations of ¹³¹I in the sewage treatment plant appear during weekends.

Table 3. Radionuclide activities used in the hospitals that discharge to the Viikinmäki wastewater treatment plant, MBq per year combined from 2003 and 2006

MBq/year				
Nuclide	T _{1/2}	diagnostic	therapeutic	total
^{99m} Tc	6.0 h	2 354 500		2 354 500
²⁰¹ Tl	3.0 d	109 000		109 000
¹³¹ I	8.02 d	21 500	305800	327 300
¹⁸ F	1.8 h	45 500		45 500
¹²³ I	13.3 h	32 900		32 900
⁶⁷ Ga	3.3 d	14 980		14 980
¹¹¹ In	2.8 d	12 990		12 990
⁵¹ Cr	27.7 d	120		120
⁷⁵ Se	120 d	18		18
⁵⁷ Co	272 d	1		1
¹⁵³ Sm	1.95 d		60 000	60 000
³² P	14.3 d		4310	4310

6.2.2 Wastewater treatment plant

Viikinmäki is the largest wastewater treatment plant in Finland and one of the largest in the Nordic countries. At Viikinmäki the wastewater of about 740 000 inhabitants in Helsinki and surrounding communities is treated. Most of the plant is located underground in rock caverns. The ventilation system from the treatment process area leads all emission to a tall chimney from where they are rapidly diluted into the atmosphere. There are eight identical lines in which wastewater are

simultaneously treated. A biological-chemical simultaneous precipitation treatment method is used. Phosphorus compounds are precipitated by adding ferrous sulphate. It is a very strongly automated system and no workers stay close to the basins for any long periods of time. During weekends normally only one person is working in the whole large plant controlling that all processes are functioning properly.

The Viikinmäki wastewater treatment plant produces about 58 000 m³ of dewatered sludge annually. The solid content of the sludge is about 30%. All sludge is composted into soil condition or landscaping material in a composting field. The twenty-hectare composting area was built to hold the entire sludge output. The area is covered by watertight rubber bitumen asphalt in order to prevent rainwater and seepage from reaching the groundwater. All leakage from the area is via pipes returned back to Viikinmäki for further treatment. Wood bark and peat are used as stabilizing materials in the sludge composting process, which lasts about one year. Various minerals and nutrients are added as needed. The mixture is screened and then marketed for gardening and landscaping purposes. The effluent from the plant flows through an outfall tunnel to a discharge area in the sea 8 kilometres off Helsinki.

6.2.2.1 Sewage water

Radionuclides in samples collected from the incoming sewage and the final effluent during 24 h were measured gammaspectrometrically in a Marinelli-beaker with a volume of 530 ml. The collecting period was from 8 o'clock in the morning to 8 o'clock the following morning. The calculated activities were corrected for physical decay back to the midpoint of the collecting period.

6.2.2.2 Sludge

The sludge samples were collected from the primary and the dewatered, digested sludge (dry material about 30%). The percentage of dry material in the dewatered sludge samples was determined after drying the sludge at 105°C. The dewatered sludge samples, about half a litre each, were packed into Marinelli-beakers without any pre-treatment and measured gammaspectrometrically. The primary sludge sample (about 1 litre) was dried at 105°C over night, grinded and measured in a beaker (28 ml). To study whether or not drying causes vaporization of iodine from sludge the dewatered sludge sample was first measured directly in the Marinelli geometry and after that the dewatered sludge was dried in oven at 105°C and measured in a beaker. The activity concentration of ¹³¹I was 93.4 ± 1.9 Bq kg⁻¹ dry weight in the direct measurement and 99.6 ± 9.9 Bq kg⁻¹ dry weight after drying in oven. The conclusion is that the ¹³¹I is fixed in the sludge so that during the drying at 105°C it does not vaporize from the sludge.

6.2.2.3 Air sample

The ventilation system of the treatment process area in the Viikinmäki wastewater treatment plant transports all emissions to a tall chimney from where it is rapidly diluted into the atmosphere. Two air samples were taken from the discharge air in a pipe using activated carbon and glass fibre filters. The samples were collected from the air from the wastewater treatment process, excluding the air from the sludge processing. The activated carbon and the glass fibre filters were measured gammaspectrometrically, carbon in Marinelli-beaker and glass fibre filter in a plastic vial.

6.2.3 Fucus vesiculosus sample

The final effluent from the Viikinmäki wastewater treatment plant flows through an outfall tunnel to a discharge area in the sea 8 kilometres off Helsinki. *Fucus vesiculosus* samples were collected in the sea in front of Katajaluoto, near the outfall tunnel. The *Fucus* samples were measured directly gammaspectrometrically in Marinelli-beakers without any pre-treatment. After the measurement the *Fucus* samples were dried at 105°C and the dry weight of the samples were determined.

6.2.4 Measurements

All samples were measured gammaspectrometrically with Ge(Li) or high purity germanium detectors. The measurement time for the water and sludge varied from 40 to 3 980 min. The total uncertainty of the

analysis of radionuclides (95% confidence level) includes the calibration uncertainty of the measuring equipment and the statistical uncertainty of the measurement.

6.3 Results

During a two weeks period the water and sludge samples were taken in the Viikinmäki wastewater treatment plant.

Table 4. Concentration of medically used radionuclides in incoming wastewater

Sampling period	Measuring time Min	Incoming wastewater (Bq l ⁻¹)			
		¹³¹ I	^{99m} Tc	¹¹¹ In	¹⁵³ Sm
13.3.-14.3.06	233	1.45±0.21	0.62±0.14	nd	nd
14.3.-15.3.06	164	1.32±0.32	1.43±0.26	nd	nd
15.3.-16.3.06	113	7.42±0.89	1.32±0.29	nd	nd
16.3.-17.3.06	125	9.11±0.91	1.16±0.26	nd	nd
17.3.-18.3.06	108	9.64±0.96	0.86±0.26	nd	nd
18.3.-19.3.06	75	6.84±1.10	nd	nd	nd
19.3.-20.3.06	203	2.59±0.41	nd	nd	nd
20.3.-21.3.06	152	1.44±0.37	0.83±0.22	nd	nd
21.3.-22.3.06	333	0.60±0.18	1.37±0.19	nd	nd
22.3.-23.3.06	340	0.29±0.15	1.07±0.17	0.22±0.09	nd
23.3.-24.3.06	1310	0.26±0.06	0.65±0.23	nd	0.28±0.05
24.3.-25.3.06	452	9.66±0.77	nd	nd	nd
25.3.-26.3.06	1426	6.34±0.38	nd	nd	nd
26.3.-27.3.06	150	2.87±0.29	nd	nd	nd

nd= below the detection limit

Table 5. Concentration of medically used radionuclides in outgoing water

Sampling period	Measuring time min	Final effluent (Bq l ⁻¹)			Discharge m ³ /d
		¹³¹ I	^{99m} Tc	¹¹¹ In	
13.3.-14.3.06	193	2.69±0.22	nd	nd	198156
14.3.-15.3.06	151	1.90±0.38	nd	nd	211404
15.3.-16.3.06	156	1.25±0.35	nd	nd	207452
16.3.-17.3.06	222	5.74±0.57	nd	nd	210862
17.3.-18.3.06	162	4.66±0.56	nd	nd	217569
18.3.-19.3.06	1120	5.36±0.21	nd	nd	208503
19.3.-20.3.06	189	3.21±0.26	nd	nd	209108
20.3.-21.3.06	1303	1.61±0.16	nd	nd	211616
21.3.-22.3.06	1114	1.54±0.15	nd	nd	213825
22.3.-23.3.06	1040	0.86±0.12	nd	nd	209287
23.3.-24.3.06	3980	0.59±0.07	nd	0.09±0.03	217743
24.3.-25.3.06	875	0.82±0.15	nd	nd	210912
25.3.-26.3.06	364	4.71±0.28	nd	nd	206034
26.3.-27.3.06	874	3.70±0.15	nd	nd	207899

Table 6. Concentration of radionuclides in primary sludge Bq kg⁻¹ dry weight.

Measuring time	Medically used radionuclides	Other radionuclides
----------------	------------------------------	---------------------

Sampling date	min	¹³¹ I	²⁰¹ Tl	¹¹¹ In	⁷ Be	⁴⁰ K	¹³⁷ Cs
13.3.2006 9:30	249	1230±20	59±24	nd	nd	154±40	12.0±2.9
14.3.2006 9:30	1008	1660±30	118±26	nd	nd	171±24	7.5±1.5
15.3.2006 9:30	1171	1670±30	102±25	nd	nd	182±22	12.7±1.5
16.3.2006 9:30	1194	1580±60	97±29	nd	nd	205±53	13.6±3.3
17.3.2006 9:30	63	1350±50	nd	nd	nd		16.0±6.4
18.3.2006 9:30	138	1210±50	95±40	nd	nd	145±52	13.2±4.0
19.3.2006 9:30	1126	1370±30	90±23	nd	16.7±6.7	173±21	9.1±1.5
20.3.2006 9:30	167	1440±60	nd	nd	nd	151±51	15.0±3.9
21.3.2006 9:30	1035	1550±30	77±21	nd	15.7±6.9	221±31	11.0±1.7
22.3.2006 9:30	54	1210±50	nd	nd	nd		15.2±6.4
23.3.2006 9:30	40	1210±70	nd	nd	nd		15.6±8.1
24.3.2006 9:30	363	920±55	nd	nd	nd		14.3±5.7
25.3.2006 9:30	1087	947±38	68±15	4.8±1.0	21.8±4.8	204±24	13.3±1.6
26.3.2006 9:30	158	902±54	59±22	3.6±2.0	nd	199±44	14.5±3.2

Table 7. Concentration of radionuclides in dewatered, output sludge Bq kg-1 dry weight (All samples taken at 9:30)

Sampling date	Measuring time min	Medically used radionuclides			Other radionuclides			dry weight %
		¹³¹ I	¹¹¹ In	²⁰¹ Tl	⁷ Be	⁴⁰ K	¹³⁷ Cs	
13.3.2006	1014	277±6	1.31±0.29	21.5±5.2	21.8±2.6	91.7±7.3	12.1±0.7	26.75
14.3.2006	1002	329±7	0.97±0.27	23.8±5.7	24.7±3.0	91.8±7.3	13.6±0.8	24.14
15.3.2006	152	283±11	nd	nd	22.1±6.6	106±17	13.5±1.6	25.51
16.3.2006	221	293±6	nd	15.8±6.6	19.1±4.6	94.2±13.2	12.5±1.2	25.39
17.3.2006	163	286±6	nd	nd	19.6±5.5	81.4±13.0	12.9±1.5	26.55
18.3.2006	1127	289±11	nd	26.2±5.8	18.3±3.7	93.0±11.2	13.0±1.3	26.89
19.3.2006	1021	288±6	nd	16.7±4.0	18.5±2.6	89.4±7.1	12.2±0.7	27.50
20.3.2006	106	300±12	nd	nd	24.1±7.2	80.9±16.2	10.5±1.7	27.40
21.3.2006	218	335±7	nd	18.8±7.9	21.2±5.1	98.9±13.8	12.4±1.2	23.97
22.3.2006	214	369±7	nd	24.6±9.4	24.8±5.5	86.3±12.1	13.3±1.3	26.31
23.3.2006	67	337±13	nd	nd	13.3±6.9	100±24	12.3±2.2	25.00
24.3.2006	76	349±14	nd	nd	32.8±9.8	110±24	11.7±2.1	26.57
25.3.2006	170	313±6	nd	nd	15.5±5.6	76.6±13.8	13.4±1.6	26.23
26.3.2006	44	365±15	nd	nd	nd	90.2±28.9	13.1±2.6	25.19

The radionuclides from the natural series were also detected in the sludge samples

The influence of the therapeutic procedures in hospitals with ¹³¹I on the activity of incoming and outgoing water in the treatment plant is presented in Figure 3. The maximum measured daily activity concentration of ¹³¹I was 9.6 Bq dm⁻³. The total amount was then 2 097 MBq of ¹³¹I per day. The total amount of ¹³¹I during two weeks was 12 500 MBq in the incoming and 8 100 MBq in the outgoing water, respectively. In these experiments the highest activity concentration of ¹³¹I measured in the primary sludge was 1 670 Bq kg⁻¹ dry weight and in the dewatered output sludge 369 Bq kg⁻¹ dry weight which corresponds to a concentration of 97 Bq kg⁻¹ wet weight (Fig. 4). The ¹³¹I collected in the primary sludge during this period was 1 090 MBq.

On March 23, 2007, 5 550 MBq (2590 MBq + 2960 MBq) of ¹⁵³Sm EDTMP was used for therapies in the hospital. In the wastewater treatment plant 61 MBq of ¹⁵³Sm was detected in the incoming sewage during the same day.

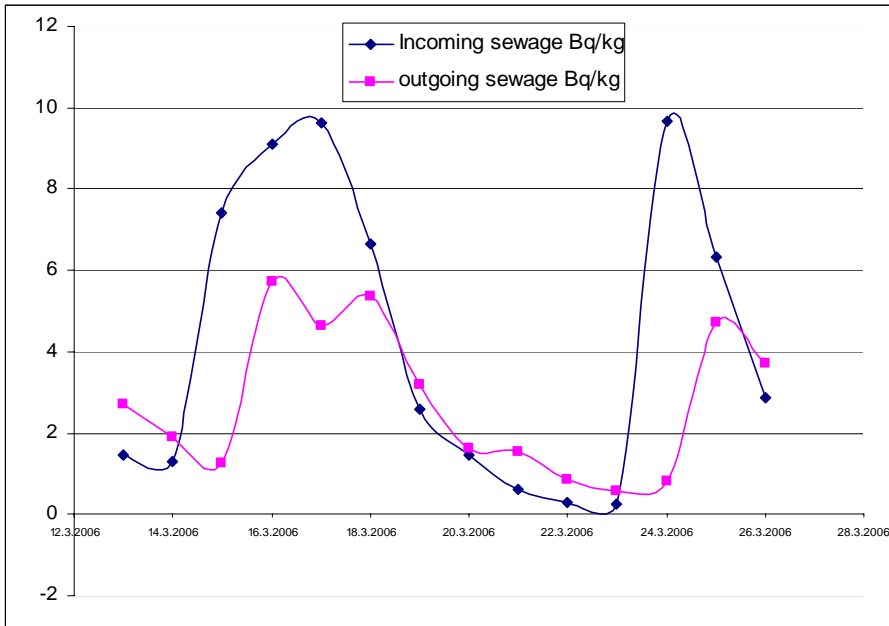

Figure 3. Activity concentration of ^{131}I (Bq kg^{-1}) in incoming and outgoing sewage in the Viikinmäki, Helsinki, wastewater treatment plant

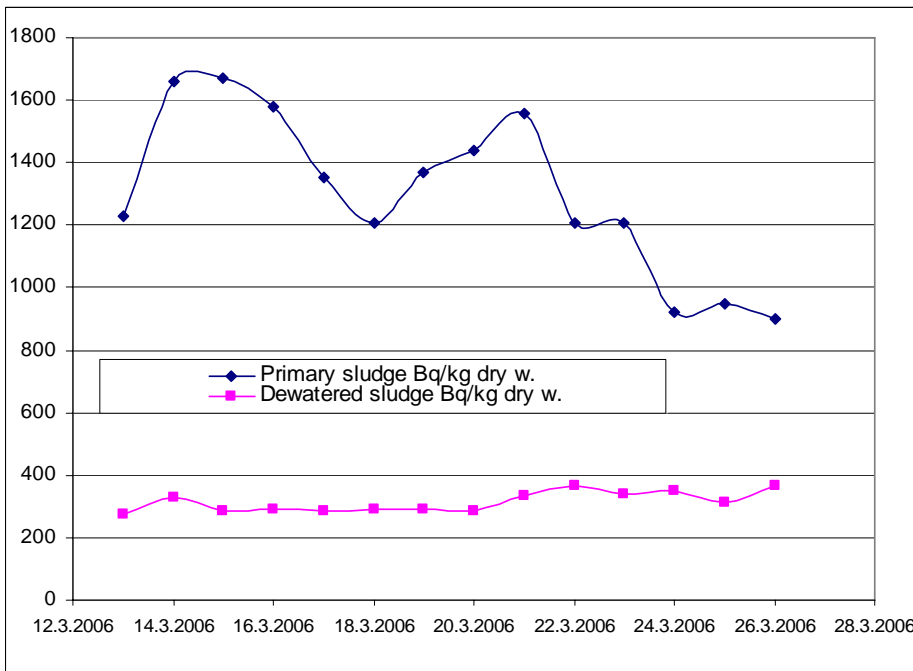

Figure 4. Activity concentration of ^{131}I (Bq kg^{-1} dry wt.) in primary and digested, dewatered sludge at the Viikinmäki, Helsinki, wastewater treatment plant

The residence time of water in a wastewater treatment plant is very short, less than 24 hours. The ^{131}I for the therapeutic procedures was administered to patients usually before noon or at noon. The highest activity concentrations of ^{131}I in the incoming sewage in the wastewater treatment plant were found during the same or the following day. After that the activity concentration of ^{131}I decreased quickly and most of the excreted activity was detected in the treatment plant within three or four days. The maximum in primary sludge was found about three days later than in the incoming sewage.

Table 8. Activities of ¹³¹I in water and sludge compared to the administered activities

Date	Administered activity		Incoming sewage MBq d ⁻¹	Outgoing sewage MBq d ⁻¹	Primary sludge MBq d ⁻¹	Dewatered sludge MBq d ⁻¹
	MBq	Form				
7.3.2006	3700	MIBG				
10.3.2006	7400	Iodid				
13.3.2006			287	533	73.8	16.6
14.3.2006			278	402	99.7	19.8
15.3.2006	3700	Iodid	1539	259	100.3	17.0
16.3.2006			1920	1210	94.9	17.6
17.3.2006	3700	Iodid	2097	1013	81.1	17.2
18.3.2006			1385	1118	72.3	17.3
19.3.2006			542	671	82.1	17.3
20.3.2006			305	341	86.2	17.0
21.3.2006			127	329	93.3	20.1
22.3.2006			61.6	180	72.4	22.1
23.3.2006			57.2	128	72.5	20.2
24.3.2006	3700	Iodid	2037	172	55.2	20.9
25.3.2006			1306	970	56.8	18.8
26.3.2006			597	769	54.1	21.9

Only a minor part of the ¹³¹I activity coming into the wastewater treatment plant leaves with the sludge. When the radioactive decay is taken into account, most of the activity, about 71-72% of the radioiodine in the incoming sewage, remains in the water and is released into the sea. About 12% was found in the sludge.

Radionuclides other than iodine detected during this test period in the incoming sewage were ^{99m}Tc, ¹¹¹In and ¹⁵³Sm and in the final effluent only ¹¹¹In. In the primary sludge of medically used radionuclides (other than iodine) also ²⁰¹Tl and ¹¹¹In were detected and originating from the Chernobyl accident ¹³⁷Cs as well as the natural radionuclides ⁷Be and ⁴⁰K.

Comparing the radionuclides used in hospitals to those detected in the wastewater treatment plant the removal of nuclides from the wastewater during the treatment process can be estimated. In incoming water ^{99m}Tc was often detected but not in outgoing water. Therefore it can be supposed that most of the ^{99m}Tc is accumulated in the sludge. This, however, could not be quantified owing to the short half-life of ^{99m}Tc. Also the shortlived radionuclides ¹⁸F and ¹²³I were not detected.

About half of the ¹¹¹In seems to be accumulated in the sludge during the treatment process. When comparing the amounts of ²⁰¹Tl used in hospitals to the amounts in sludge, it seems that most of the ²⁰¹Tl is accumulated in sludge. Earlier ⁵¹Cr, ⁷⁵Se and ⁵⁷Co were sometimes detected in sludge. Lately ¹⁵³Sm has been detected in sludge and it can be assumed that most of the released samarium is accumulated in sludge during the wastewater treatment process.

Over 90% of phosphorus is removed from water during the treatment process. ⁶⁷Ga is administered as citrate and the biological half-life of Ga-citrate is about 25 d. ⁶⁷Ga can not be detected in the sewage because of its much shorter physical half life. ³²P is a pure beta-emitter and cannot be detected with gamma measurements.

6.3.1 Air sampling

A small amount of ¹³¹I was detected in the activated carbon filters. In the glass fibre filters the activity concentration of ¹³¹I was below the detection limit (MDA 53 - 116 μBq m⁻³). The concentrations in the air were 191 and 738 μBq m⁻³ (Table 9). After getting information from the hospital about the administered activities to the patients and using our earlier data it was estimated what the activity in

incoming sewage should have been at that time. It was calculated that only a small fraction, about 0.0003 - 0.0006% of the ^{131}I in the incoming sewage, was transferred into the air during the waste water treatment process. The inhalation is not an important pathway for the doses of workers.

Table 9. ^{131}I in air in the Viikinmäki wastewater treatment plant

Administered activity	Sampling period	Sampling speed	Amount of air	^{131}I in outflow air	
Date	MBq	l s^{-1}	m^{-3}	$\mu\text{Bq m}^{-3}$	kBq d^{-1}
19.3.2007	7.4				
20.3.2007	3900				
21.3.2007	7.4				
		22.3.07 14:30 - 23.3.07 1	3.9	302	191 ± 103 1.8
26.3.2007	3890				
	1137				
	8.04				
28.3.2007	3800	28.3.07 14:13 - 29.3.07 1	3.8	317	738 ± 162 7.1

6.3.2 Fucus samples

Table 10. Activity concentrations in Fucus vesiculosus

Sampling date	Sampling depth	Bq kg^{-1} d.w.			
		^7Be	^{40}K	^{131}I	^{137}Cs
11.6.2007	2-3.5	29 ± 5	901 ± 108	102 ± 12	19.6 ± 2
11.6.2007	3.5-4.5	48 ± 9	874 ± 140	52 ± 7	19.8 ± 3

In 2007 two samples were taken at different depths. The concentrations of ^{137}Cs and ^{40}K were of the same level in both samples, there was a difference only in the concentration of ^{131}I . It was obvious that there is the same kind of pulses in Fucus as in sewage and sludge. ^{131}I is used in therapy one or two times every week. So the ^{131}I can be detected in sewage water and primary sludge and in fucus continuously and there are one or two pulses a week.

Sweden

6.4 Introduction

The Kungsgärdet wastewater treatment plant in Uppsala, serving the Uppsala University Hospital, was selected as representative for the study. However, it was realised that the iodine treatments at this hospital were less frequent than at the Lund University Hospital. It was therefore decided to also include the Lund University Hospital in the study, which releases into the Källby wastewater plant. The radionuclides of main interest were ^{131}I , ^{111}In and ^{177}Lu . The latter is particularly used at the Uppsala University Hospital.

Twenty-four-hour composite samples of incoming and outgoing wastewater and spot samples of sludge were collected as described above. The treatment processes are somewhat similar between the studied plants except that the secondary sludge fraction is directly fed back into the biological treatment process at Källby. For both plants the digested sludge is mainly used as landfill, after storage for more than three weeks. It should also be noted that the Källby plant is much smaller than the Kungsgärdet plant.

6.5 Methods

Detailed measurements were performed on samples from the two different treatment plants. The measurements were done following radioiodine therapy at the hospitals, in order to correlate the radioactivity in the sludge with the amounts of iodine administered to the patients (see table below). Similar sampling techniques were applied at the two plants, namely using a composite sampler that operates continuously to obtain representative samples. Twenty-four-hour composite samples of the influent and effluent were collected. Grab samples were taken on primary and secondary sludge during each day while grab samples of digested sludge were taken less frequently. The samples were collected in 1000 ml bottles and transported to SSI in cold. An aliquot of the sample was transferred to a Marinelli beaker and then measured using a gamma spectrometer. The samples were not dried before the measurements as stated in the measurements protocol, but filtered. Corrections for physical decay were done.

Table 11. Administered activities for treatments of patients in the hospital served by the Kungsgärdet and the Källby sewage plants

Date	Nuclide	GBq	Form	Place
7.6.2005	¹³¹ I	9,9	MIBG	Lund
28.3.2006	¹³¹ I	7,4	Iodide	Uppsala
4.4.2006	¹³¹ I	4	Iodide	Uppsala
19.4.2006	¹³¹ I	4	Iodide	Uppsala
19.10.2007	¹³¹ I	7,4	Iodide	Lund

6.6 Results

Table 12. Measured concentrations of radionuclides in water at the Kungsgärdet and the Källby sewage plant following nuclear medical treatment at the hospitals.

Sampling date	Concentration of radionuclides in water , (Bq/kg) (WW)							
	Incoming water				Outgoing water			
	I-131	Lu-177	Tc-99m	Bi-214	Pb-214	I-131	Lu-177	In-111
7-jun-05	2±11,7					6,4±5,9		
8-jun-05	9,9±1,5		238±15,3			5,1±2,5		
9-jun-05	165±1,4					29±1,7		
10-jun-05	28±2,8					31±1,4		
17-jun-05	3±2,6					10±2		
4-aug-05	0,6±2,9					0,2±8,4		
28-mar-06	63±1,8					1,6±4		
29-mar-06	25±6,2					15±4,5		
30-mar-06	27±2	138±4,8				11±1,3	8±1,9	
2-apr-06	4,5±3,1	3±9,6				3±4,5	7±8,3	
5-apr-06	71±1,1					4±3,4		
6-apr-06	21±4,5	185±5,7				13±4,1		
7-apr-06	3,4±2,8	12,8±5,5				6,1±3,3	18±6,6	
10-apr-06						1±9,1		
19-apr-06						0,3±11,3		
20-apr-06	175±2,1	112±5,8	101±9,9	20,2±4	17±4			
24-apr-06						3,6±2,5		
25-apr-06	3,2±4,2							
18-oct-07	MDA 0,5					1,3±0,06		
19-oct-07	MDA					0,9±0,1		
22-oct-07	4,6±0,3		98±4,8			14±0,3		
23-oct-07	0,8±0,005					8±0,2		
24-oct-07	MDA					8±0,2		
25-oct-07						5,6±0,1		4,3±1
26-oct-07						3,2±0,3		
29-oct-07	1,6±0,1					2±0,2		

Table 13. Measured concentrations of radionuclides in sludge at the Kungsgärdet and the Källby sewage plant following nuclear medical treatment at the hospitals.

Sampling date	Concentration of radionuclides in sludge (Bq/kg ww)						
	Primary sludge				Secondary sludge		
	I-131	Lu-177	In-111	Tc-99m	I-131	Lu-177	In-111
7-jun-05	266±1,6				188±2,5		
8-jun-05	211±1,7						
9-jun-05	862±1,2				289±1,7		
10-jun-05	528±1,5				289±2,3		
17-jun-05	553±1,8				215±1,5		
4-aug-05	4,6±5,1				3,6±7		
27-mar-06		11±11				8,3±13,5	
29-mar-06	336±1,5	14±26			29±4		
30-mar-06	437±1,6				48±1,9		
31-mar-06	235±2,1	256±5,6			63±4,9	118±7,7	
3-apr-06	50±2,3	61±5,6			39±1,8	39±5,5	
5-apr-06	53±2	27±5,2		22±2,9	25±1,4	20±1,8	
6-apr-06	48±3	28±9		7±8,4	60±1,5	12±6,1	
7-apr-06	53±3,3	153±5,9		9±6,7	57±3,8	63±8,5	
10-apr-06	10±7,9	72±7,4			31±2,1	20±4,3	
11-apr-06	19±5,3	60±7,5			28±4,8	26±12,4	
19-apr-06	12±7,6			9±9	15±6,2		
20-apr-06	11±5,4			5±7,9	12±8		
21-apr-06	5,1±12	69±8,1		21±6,5	57±3,2	46±8,3	
24-apr-06	84±2,4				85±3		
18-oct-07	204±4	7,2±1,7	6,9±0,4		185±2,5		3,4±0,2
19-oct-07	117±6				131±4,4		
22-oct-07	482±13				355±7,5		
23-oct-07	423±10,7				322±7,8		
24-oct-07	253±3,9			40±4,6	357±6,4		
25-oct-07	247±6,7				211±4,8		
26-oct-07	407±6,1				196±4,3		
29-oct-07	341±5,2						

Table 14. Comparison of the concentrations of ^{131}I in wet, dried and filtered sludge

Sample	Concentration of ^{131}I (Bq/kg)
Primary sludge, 18-oct 2007, wet weighth	204+/- 4
Primary sludge, 18 -oct 2007, dried over night at 105°C covered with folie	8120+/-230
Primary sludge, 18-oct 2007, dried over night uncovered	8560+/-730
Secondary sludge, 18-oct 2007 wet weight	185±2,5
Secondary sludge, 18-oct 2007 dried over night, covered with folie	13800±500
Secondary sludge, 18-oct 2007, dried over-night uncovered	16000±1360
Secondary sludge 22-oct 2007, wet weight	355±7,5
Secondary sludge 22-oct 2007, filtered	7980±152
Secondary sludge 22-oct 2007, filtrate	46±1,5
Secondary sludge, 23-oct 2007, wet weight	322±7,8
Secondary sludge, 23-oct 2007, filtered	6100±89
Secondary sludge, 23 -oct 2007, filtrate	37±1,9
Secondary sludge 24-oct 2007, wet weight	357±6,4
Secondary sludge, 24-oct 2007, filtered	6290±103
Secondary sludge, 24-oct 2007, filtrate	35±3,4
Primary Sludge, 9-jun 2005 wet weight	862±1,2
Primary sludge, 9-jun 2005 filtered	1945
Primary Sludge, 9-jun 2005 filtrate	217

Table 15. Concentration of radionuclides in digested sludge at the Kungsgärdetand Källby sewage plant

Sampling date	Concentration of radionuclides in digested sludge (Bq/kg) (WW)	
	I-131	Lu-177
8-jun-05	73±2,6	
22-jun-05	117±1,4	
4-aug-05	14±2,7	
27-mar-06		48±9,3
19-apr-06	22±3,5	25±8,1
23-oct-07	190±2,7	
30-oct-07	222±5,1	

6.7 Measurements of ^{177}Lu releases from the Uppsala University Hospital

At the Uppsala University Hospital patients are frequently treated with ^{177}Lu . The retention of the administered activity is comparatively short and most of the activity is therefore assumed to go rather directly the sewage plant. In order to investigate the time of the activity to reach the sewage plant and the release pattern an intensive twenty-four-hour sampling period was performed at Kungsgärdet.

7,4 GBq of ^{177}Lu was delivered to two patients at the same day before noon. Samples of the incoming water were taken every second hour the following day at the sewage plant. Aliquots of the wet samples were measured with a NaI detector. As seen in figure 5 the release entered the sewage plant as a pulse and peaked about 28 hours after administered.

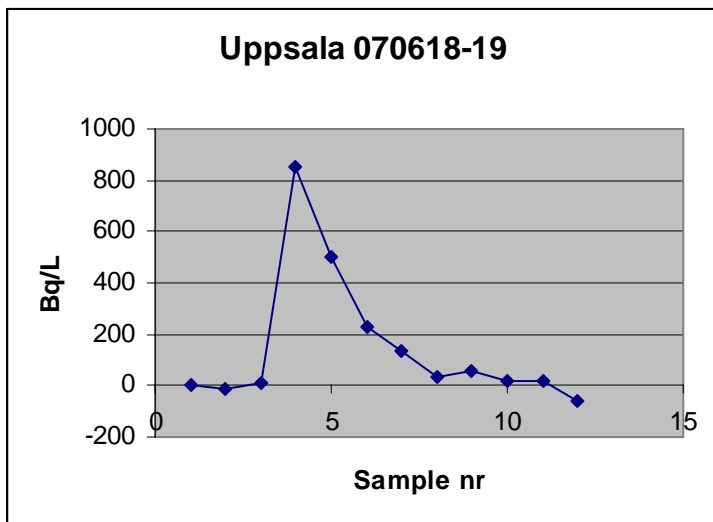

Figure 5. The measured pulse release of ^{117}Lu in the influent of the Kungsgårdet sewage plant.

Norway

6.8 Introduction

The VEAS wastewater treatment plant is serving a large part of the city of Oslo and three neighbouring municipalities (totally 450 000 people). It started its operation in 1982 and was originally a pre-precipitation plant for phosphorous removal. As a result of the North Sea Agreement, VEAS was rebuilt during the years 1991-97 and since then it has been in full operation as a combined nitrogen and phosphorus removal plant.

The VEAS plant serves two major hospitals (Rikshospitalet-Radiumhospitalet Hf and Ullevål universitetssykehus) and some minor ones (Aker, Bærum, Lovisenberg and Diakonhjemmet). 95 – 120 mil m^3 of wastewater is treated at VEAS annually. The residence time of water in the plant is 3 hours. After the removal of the solid parts (sludge), the treated effluent which has a low level of phosphates and nitrogen compounds is discharged into the Oslo fjord at a depth of 50 m, 700 m offshore. The separated solids are biologically stabilised, hygienised and dried. This is the final product and is referred to as VEAS bio solids and is mainly used as soil conditioner on grain fields. Approximately 25000 tons of VEAS bio solids are produced annually.

The major hospitals connected to VEAS routinely use radionuclides for therapeutic and diagnostic purposes. This leads to the release of radioactivity to the sewer system (environment) both as the waste from hospitals and as the excreta of patients.

6.9 Methods

VEAS collected 6 samples daily for 13 days. Considering the two weekends in between, the sampling period lasted for 17 days (13 – 29 September 2006). Sample collection was initiated 2 days before the first scheduled therapy treatment at the Rikshospitalet. A patient was treated at noon 15 September with 4 GBq of Na^{131}I and stayed at the hospital for two days after the treatment. This was also the case for another patient treated at the same hospital on the following Friday (22 September). As shown in Table 16 patients at the other hospitals have also been treated with radioiodine during the sampling period.

Table 16. An overview of all radioiodine therapy treatments administered during the sampling period at hospitals connected to the VEAS plant.

Date	Type	Activity (MBq)	Hospital
12/9/2006	131I-NaI	6000	Radiumhospitalet
15/9/2006	131I-NaI	3700	Radiumhospitalet
15/9/2006	131I-NaI	4000	Rikshospitalet
21/9/2006	131I-NaI	4500	Radiumhospitalet
22/9/2006	131I-NaI	4000	Rikshospitalet
25/9/2006	131I-NaI	7000	Ullevål universitetssykehus
26/9/2006	131I-MIBG*	7400	Radiumhospitalet

* Meta (¹³¹I) IodoBenzylGuanidine

Employing a continuously operating sampler, twenty-four-hour composite samples of incoming and outgoing water, grab samples of primary sludge were collected daily. The collection period was in the morning. The measured activities were corrected for physical decay and the midpoint of the collection period was used as reference date. Water and wet sludge samples were delivered to the laboratory on the same day they were taken, whereas the dried samples were delivered the day after.

All samples were measured using high-purity germanium detectors. All measurements were conducted with a maximum delay of 2 days.

6.10 Water samples

Two water samples were collected daily (one from incoming and one from outgoing water). The water samples were collected in (500 millilitre) plastic bottles and their activity concentrations were measured in plastic beakers (250 ml). The counting time for these samples was approximately 18 hours.

6.11 Sludge samples

Sludge samples were taken from two different sites in the plant: primary sludge from drum thickeners and digested sludge from buffer tank. Each of these samples was divided in two portions before measuring the activity. One part was measured without any pre-treatment (wet sludge) and the other part was dried at a temperature of 105 °C for 24 hours and homogenized before measurement. Wet sludge samples were kept in plastic beakers (250 ml) and measured for approximately 18 hours²⁹. Dried sludge samples (15 g) were measured for 6 hours.

Grab samples of digested sludge were taken in the same period. As the process of digestion takes almost three weeks, these samples can not be correlated to the other samples in this study, but still they might be used for monitoring purposes.

6.12 TLD measurements

In order to assess the dose received by workers at the sewage plant TLD measurements were carried out. Upon consultation with VEAS, four locations were identified as places where workers could spend most time. 9 TLDs (all LiF type) were placed at the plant for 2 months (Sep. – Nov. 2007). The number of TLDs along with locations at which they were placed is as follows:

²⁹ Three HPGe detectors were used in the course of measurement. This number of detectors did not allow for the simultaneous measurement of all samples collected at the same day. Due to this limitation, at least 13 wet sludge samples were measured for a period of ca. 6 hours.

- 2 TLDs at screens, near the inlet
- 3 TLDs at dewatering filters
- 2 TLDs at drum thickeners
- 2 TLDs at process hall

6.13 Results and Discussion

The main radionuclides used at the above mentioned hospitals during the sampling period are given in Table 17.

Table 17. Overview of radionuclides which during the two weeks of study are administrated to patients for radiotherapy and diagnostic procedures

Hospital	Diagnostics (MBq)					Therapy (MBq)	
	Tc-99m	F-18	In-111	I-123	I-131	Y-90	I-131
Radiumhospitalet	88000	14600			9	1167	21600
Rikshospitalet	82000		1400	1900			8000
Ullevål Universitetssykehus	141000			370	180		7000
Total	310000	14600	1400	2270	189	1167	36600

Although Tc-99m is the most used radionuclide, and also was detectable in almost all samples, its impact will not be discussed here as due to its short physical half life (ca. 6 hours) it is not supposed to present any radiological health concerns. The radionuclide of interest is I-131, a high-energy gamma emitter which is frequently used in hospitals for both therapeutic and diagnostic purposes.

A total of 37 GBq of ¹³¹I was administered to 7 patients for therapeutic purposes during the sampling period - with a minimum and maximum administered dose of 4 and 7.4 GBq, respectively (see Table 1). In addition to the therapy doses, 0.19 GBq of ¹³¹I was administered for diagnostic purposes in the same period.

The highest activity concentration of ¹³¹I detected in influent and effluent samples was 26 and 21 Bq/kg, respectively (see Figs. 6 and 7).

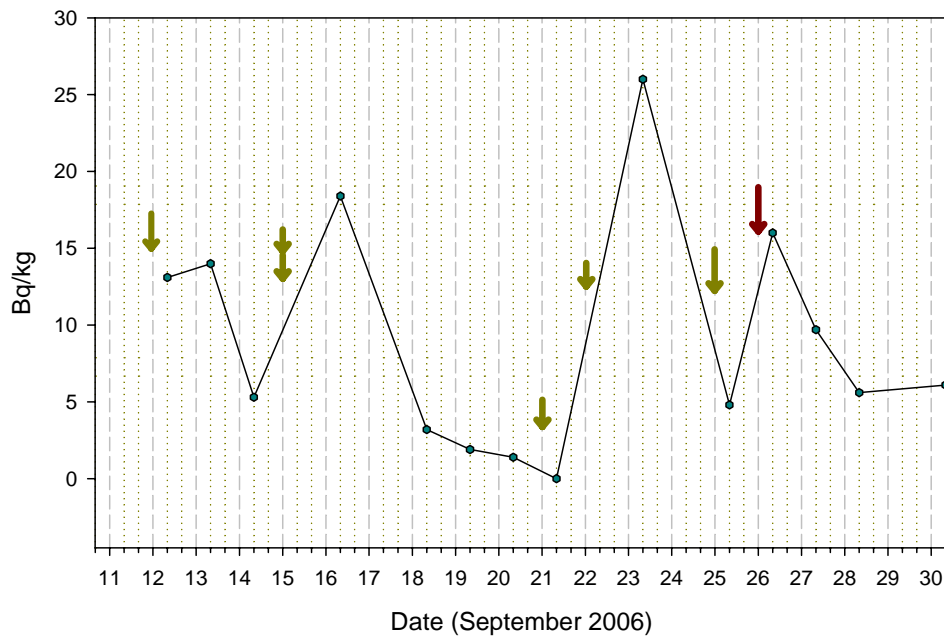

Figure 6. Concentrations of ^{131}I in influent samples. The arrows indicate days at which treatments have taken place. The dark red arrow indicates MIBG therapy

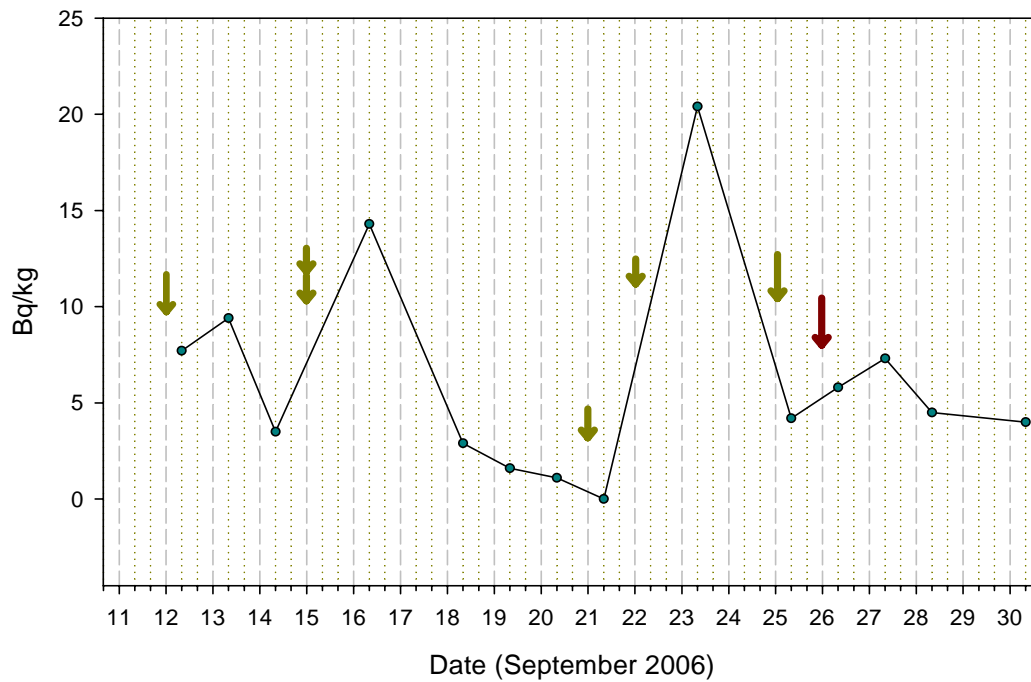

Figure 7. Concentrations of ^{131}I in effluent samples. The arrows indicate days at which treatments have taken place. The dark red arrow indicates MIBG therapy

The highest measured activity of ^{131}I detected in primary sludge was 400 Bq/kg for wet and 6200 Bq/kg for dry samples (see Figs. 8 and 9).

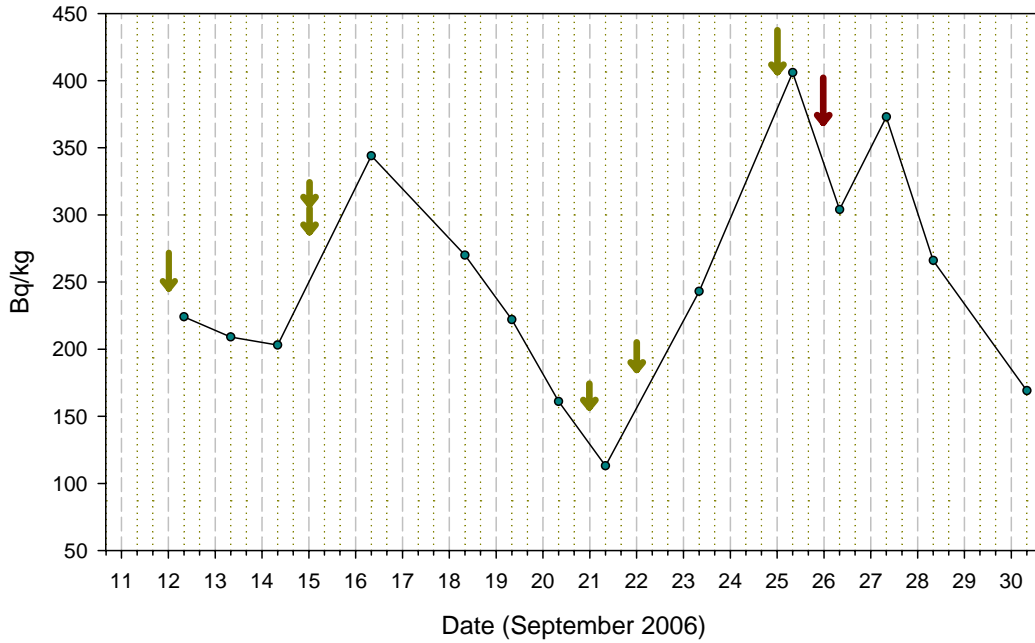

Figure 8. ¹³¹I concentrations in wet primary sludge. The arrows indicate days at which treatments have taken place. The dark red arrow indicates MIBG therapy

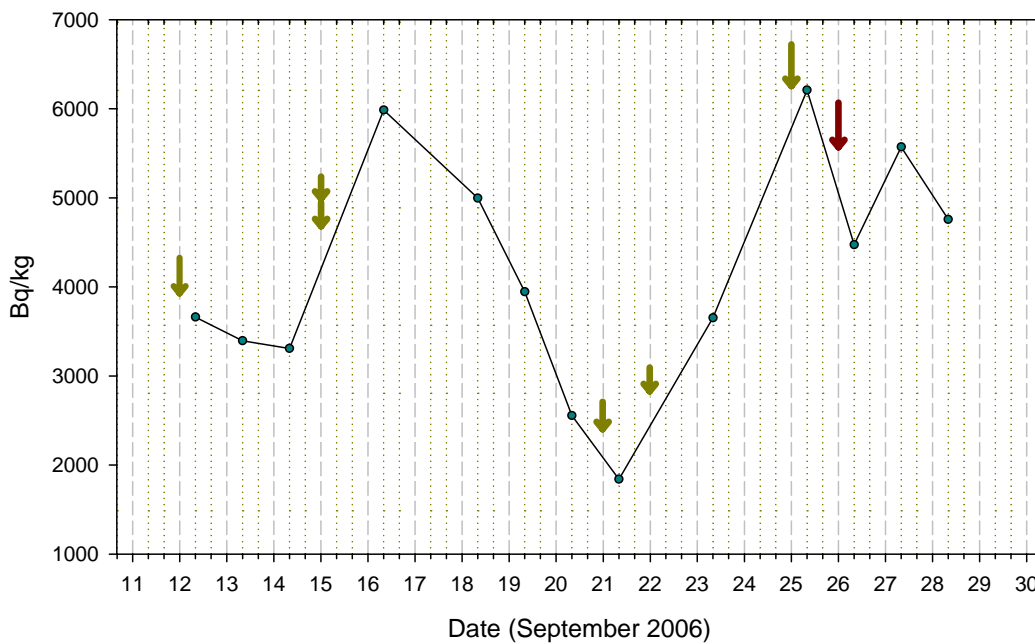

Figure 9. ¹³¹I concentrations in dry primary sludge. The arrows indicate days at which treatments have taken place. The dark red arrow indicates MIBG therapy

Radioiodine therapies are generally given at noon (between 11:00 and 13:00). Patients who receive such a therapy are required to be confined to an isolated area until the body burden of ¹³¹I is less than 10% of the initial activity. The hospitalisation time is two days during which most of the therapeutic dose will be excreted to the sewage system. Table 18 shows some measurements conducted at the Rikshospitalet and confirm that at the time of release of patients from hospitals the dose rate level in a patient who has received treatment is less than 10% of that right after treatment.

Table 18. Typical administrated activities of I-131 along with the corresponding dose rates measured at a distance of 1 meter from patient at two different times after the treatment.

Administrated activity (GBq)	Dose-rate at 1m distance ($\mu\text{Sv/h}$)	
	After 1 hour	After 48 hour
6	310	26
4.5	280	21
4	270	12

Correlations between the measured I-131 activity in collected samples and the administered activity to the patients at the hospitals were observed. The correlation easily demonstrates that sludge is the main integrator of radioactive materials. According to Fenner and Martin (1997) MIBG is more likely to be found in the sludge as opposed to Na^{131}I . This is attributed to a higher affinity of MIBG for organic material. However, as it had been administrated only one MIBG therapy just before the end of the sampling period, it is difficult to be conclusive here.

It seems that the peak of released activity following a treatment reaches the VEAS plant after approximately 32 hours (Figs. 6-9). This is particularly the case for water samples. However, the time it takes for the swage to reach the plant is not more than a few hours (ca. 8 hours). So, this observation indicates that the transport time for radioiodine is much longer than that for normal sewage. Possible reasons include the lipid coating on sewer lines that may absorb iodine, especially in the organic form. With other words, this can be due to the lipophilic nature of iodine compounds (Fenner and Martin, 1997).

Finally, the TLD measurements revealed that the dose rates in air at the plant were below detection limit. So it was concluded that the doses to VEAS workers, as a result of radionuclides released into the sewage system, is very low and consequently of no radiological health concern.

Denmark

6.14 Introduction

The Aalborg Renseanlæg Vest (ARV) waste water treatment plant is treating waste water from major parts of Aalborg and Nørresundby, located at Limfjorden, as well as other cities south and west of Aalborg involving a population of about 200 000. The ARV plant began operation in 1982 and has been further expanded since then.

The ARV plant is treating waste water from Aalborg hospital which is using radioiodine for diagnostic and therapeutic purposes.

6.15 Materials and methods

Samples of waste water and sludge were collected at the ARV during September-October 2007. Sampling was coordinated with the schedule at the Aalborg hospital for use of radioiodine. The use involves diagnostic and therapeutic applications. Diagnostic applications are made to examine thyroid disorders and patients are treated typically with 600 MBq of ^{131}I and sent home after examination. Radioiodine is subsequently discharged from patients to local sewer systems in and outside Aalborg. Therapeutic applications are made by ablation after surgical removal of thyroid and patients are treated typically with 3700 MBq of ^{131}I and kept at the hospital some time before they are sent home. At the hospital these patients use special toilets to collect radioiodine in a hold-up sewer tank, which

discharges to the ordinary sewer system according to a special routine. The schedule of radioiodine use at the hospital is shown in Table 19.

Table 19. Schedule at Aalborg hospital for use of radioiodine in September and October 2007

Date	Nuclear Medicine Dept. Diagnostic (MBq)	Oncology Dept. Ablation (MBq)
03-09-2007	1200	
04-09-2007		3700
10-09-2007	3600	
17-09-2007	1600	
18-09-2007		3700
21-09-2007		3700
24-09-2007	2200	
25-09-2007		3700
30-09-2007		3700
01-10-2007	1100	
08-10-2007	600	
15-10-2007	2200	
22-10-2007	600	
29-10-2007	3500	

Sampling of waste water and sludge was carried out weekly by ARV staff at the plant and involved water samples from primary tank, return water and exit water and sludge samples from primary tank and drained sludge, cf. Figure 10.

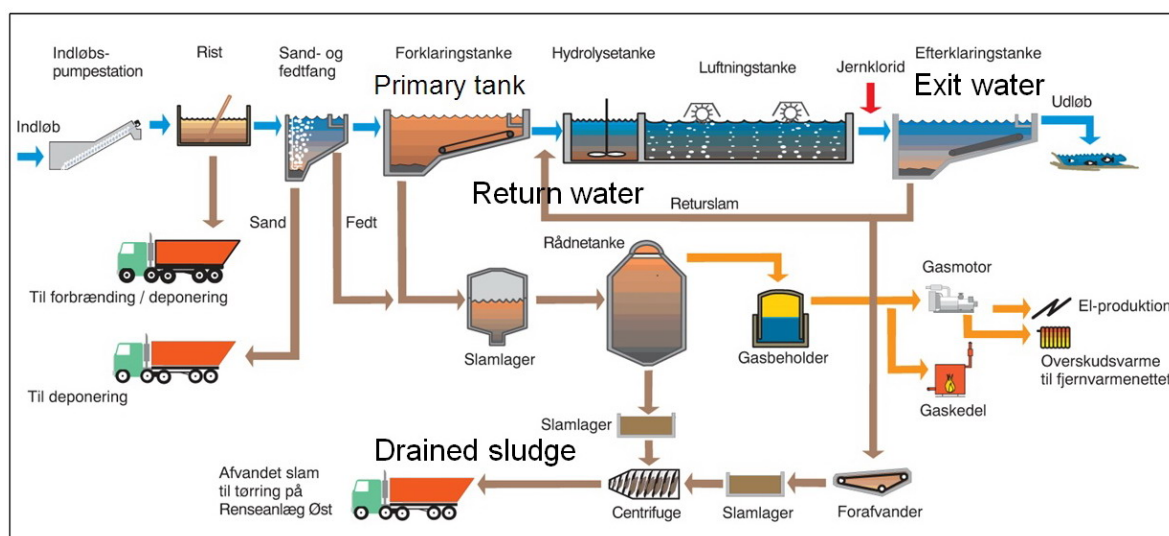

Figure 10. Schematic diagram of Aalborg waste water treatment plant showing locations for sampling of waste water and sludge from primary tank, return water, exit water and drained sludge.

The samples were sent to Risø DTU where they were analysed by gamma spectrometry using Ge detectors in 10-cm lead shields. Water samples were analysed in one-litre Marinelli containers and sludge samples of 0.03-0.07 kg dw were analysed in 200 mL cylindrical containers. Results were decay corrected to time of sampling.

6.16 Results

The ^{131}I concentrations in samples of waste water and sludge with analytical uncertainties are shown in Tables 19 and 20 and shown in column charts in Figures 11 and 12.

Table 20. Iodine-131 in waste water samples (Bq/L, 1 sd)

Date	Primary tank	Return water	Exit water
19/09/07	65.9±10%	202.5±10%	1.0±39%
26/09/07	46.5±10%	12.2±11%	3.7±12%
03/10/07	2.0±12%	89.7±10%	1.2±14%
10/10/07	0.1±45%	39.8±10%	0.6±16%

Table 21. Iodine-131 in sludge samples (Bq/kg dw, 1 sd)

Date	Primary tank	Drained sludge
19/09/07	4010±10%	180±13%
26/09/07	946±10%	427±10%
03/10/07	875±10%	308±10%
10/10/07	119±11%	127±11%

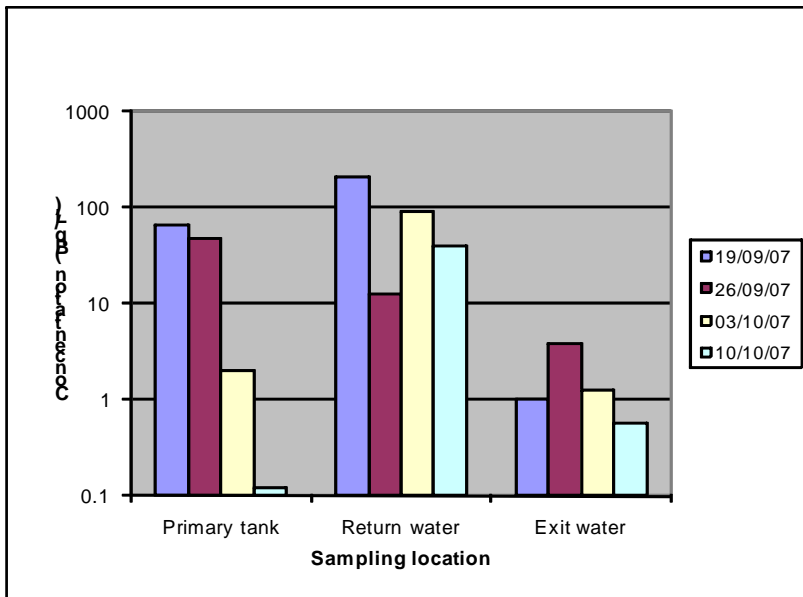

Figure 11. Iodine-131 in waste water samples (Bq/L).

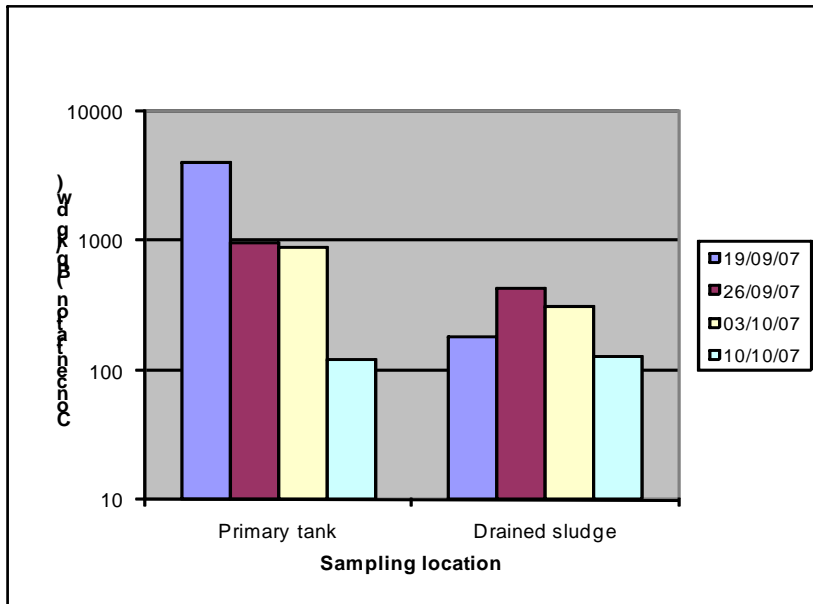

Figure 12. Iodine-131 in sludge samples (Bq/kg dw)

Values of the distribution coefficient, K_d , for iodine in the primary tank were calculated as the ratios between observed concentrations in sludge and water. The values were found in the range 20-1000 L/kg with a geometric mean value of 150 L/kg and a geometric standard deviation of 6. This value compares reasonably well with environmental K_d -values from the literature of 200 L/kg for the open ocean and of 70 L/kg for the ocean margin (IAEA, 2004).

Iceland

6.17 Summary

Two sewage plants, the Ananaust and Klettagardar plants, serve the capital area. Only mechanical cleaning of wastewater is carried out and no chemicals are being applied. These two plants serve about 60 % of the nation. The total annual discharge of sewage effluent through the sewage system is estimated to $8 \times 10^8 \text{ m}^3$.

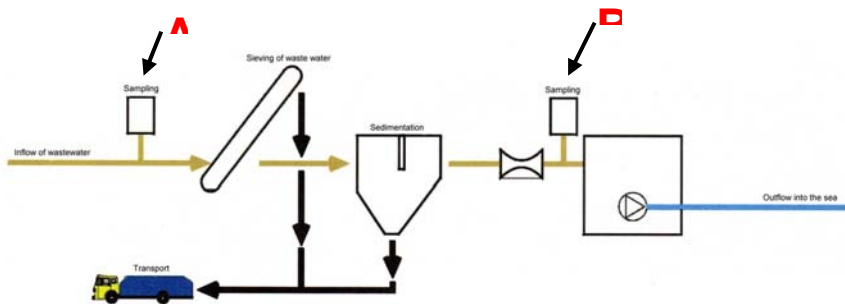

Figure 13. Skolpa Klettagardar wastewater treatment plant with the sampling places indicated.

In the Skolpa Klettagardar the incoming water is collected into three settling tanks for removal of suspended solids and fat. The sludge is transported to a dump site. No biological treatment of wastewater is carried out and the wastewater is released into the sea 5,5 km offshore. The dilution of the sewage effluent is estimated to be about 60 fold at the sea surface. The total residence time of a waste particle is 0.6 hours.

The main hospital of the country is Landspítali-University Hospital, located in Reykjavik. The usage of ^{131}I is confined to the isotope department at Hringbraut. The annual use of ^{131}I is 192 Gbq and the number of iodine therapies per year is approximately 90.

Systematic sampling of sewage effluent and sludge was performed. On October 16th a patient was treated with 7,6 GBq and continuous sampling was performed during 24 hr periods until October 20th.

The sampling procedures are illustrated in the Figure 14 below.

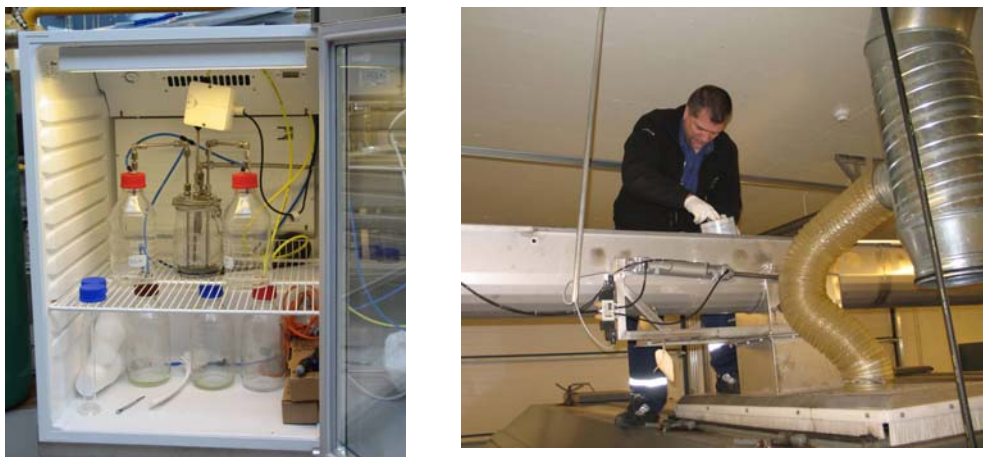
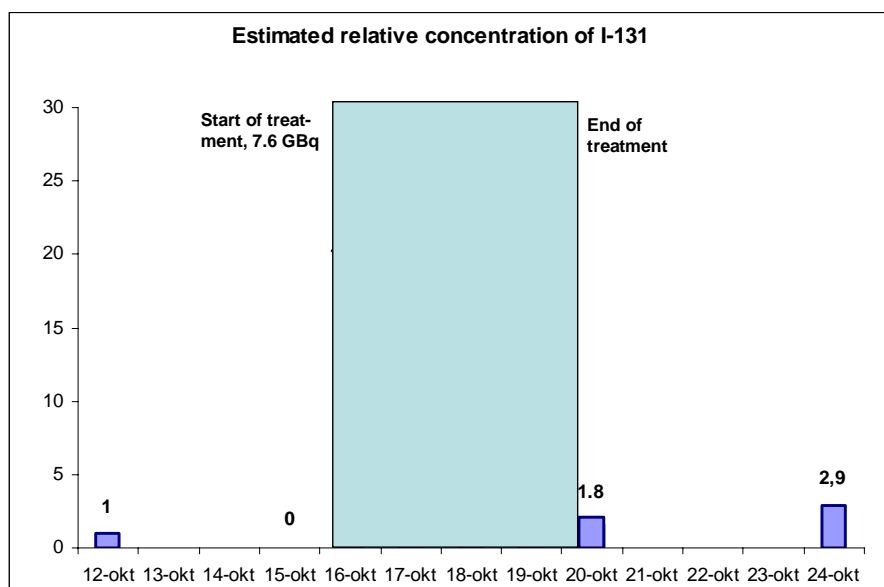

Figure 14. Sampling at Skolpa Klettagardar.

The distance between the hospital and the sewage plant is about 3 km and the flow time is estimated to be about 1 hour.

The preliminary results are shown in Figure 15 where also additional iodine treatments at the department are indicated.



Amounts of I-131 given at LSH: 7.6 GBq (16-oct), 0.3 GBq (17-oct), 0.7 GBq (24-oct)

Figure 15. The estimated relative concentration of ¹³¹I in the sewage effluent and the sludge during the measurement period at Skolpa Klettagardar

7. Intercalibration

7.1 Introduction

A laboratory intercomparison exercise was organised in 2007 in order to compare analytical results across the laboratories participating in the project. Since ¹³¹I is the dominating man-made radionuclide in sewage systems due to the medical use for diagnostic and therapeutic applications, this was an obvious candidate. Furthermore, ¹¹¹In was chosen as this radionuclide, which is used for medical diagnostic purposes, is also commonly found in sewage systems.

7.2 Samples

Wastewater sludge was collected from the wastewater treatment station at Risø DTU and together with tap water was spiked with the gamma emitting radionuclides ¹¹¹In (T_{1/2} = 2.8 d) and ¹³¹I (T_{1/2} = 8 d). The samples were well mixed prior to distribution to the participants who each received 1 L water and 50 g dw sludge. The distribution was carried out by express delivery service in order to ensure a rapid delivery to the participants who received the samples on the 14 May 2007. The participants were asked to refer their results to the 9 May 2007 at noon.

7.3 Participants

Institute	Abbreviation	Contact person
Norwegian Radiation Protection Authority, Norway	NRPA	Ali Hosseini
Risø DTU, Denmark	Risø	Sven Nielsen
National Institute of Radiation Protection, Denmark	SIS	Carsten Israelson
Swedish Radiation Protection Institute, Sweden	SSI	Inger Östergren
Radiation and Nuclear Safety Authority, Finland	STUK	Marketta Puhakainen
Uppsala University, Sweden	UU	Hans Lundqvist

7.4 Results

The gamma-spectrometric results reported on ^{111}In and ^{131}I in sludge and water are listed in Table 22 with associated uncertainties. These results are also shown in graphical form in Figures 16-19. The results on additional radionuclides in sludge reported by two participants are shown in Table 23.

Table 22. Results of ^{111}In and ^{131}I in sludge and water (Bq/kg)

Lab	Sludge		Water		Sludge		Water	
	^{111}In	1 sd	^{111}In	1 sd	^{131}I	1 sd	^{131}I	1 sd
NRPA	40,922	4,100	165	17	46,060	2,300	4,470	220
Risø	31,668	4,750	147	22	49,601	4,960	4,306	431
SIS	33,800	1,690	200	10	47,400	2,370	4,500	225
SSI	33,202	2,324	160	11	48,193	1,928	4,193	168
STUK	37,000	1,600	271	14	48,900	2,150	4,180	175
UU					33,592		3,359	

Table 23. Results of ^{51}Cr , ^{54}Mn , ^{60}Co , ^{65}Zn and ^{137}Cs in sludge (Bq/kg dw).

Lab	^{54}Mn		^{60}Co		^{65}Zn		^{137}Cs	
		1 sd		1 sd		1 sd		1 sd
Risø	1.7	0.6	32	6	18	8	22	5
STUK	6.4	0.6	50	3	9	1	44	2

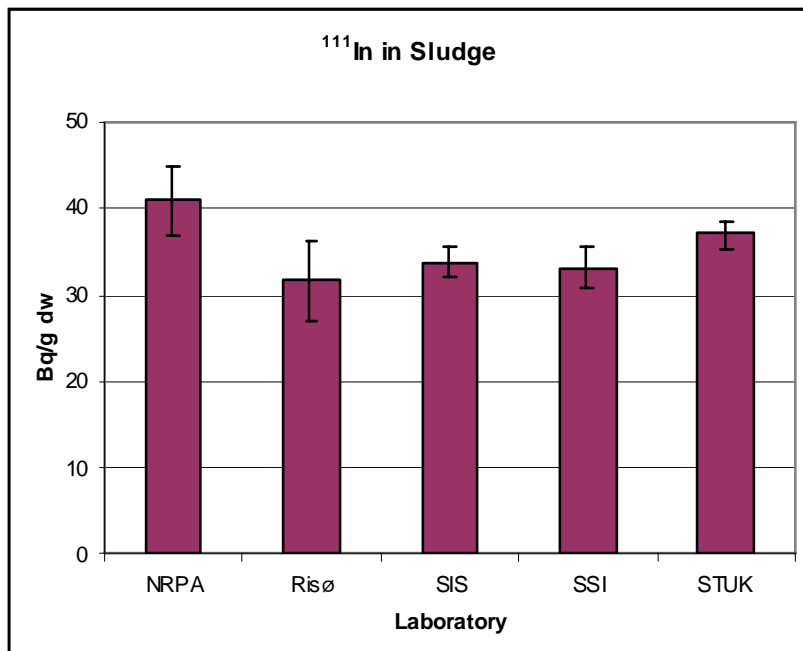

Figure 16. Results on ^{111}In in sludge

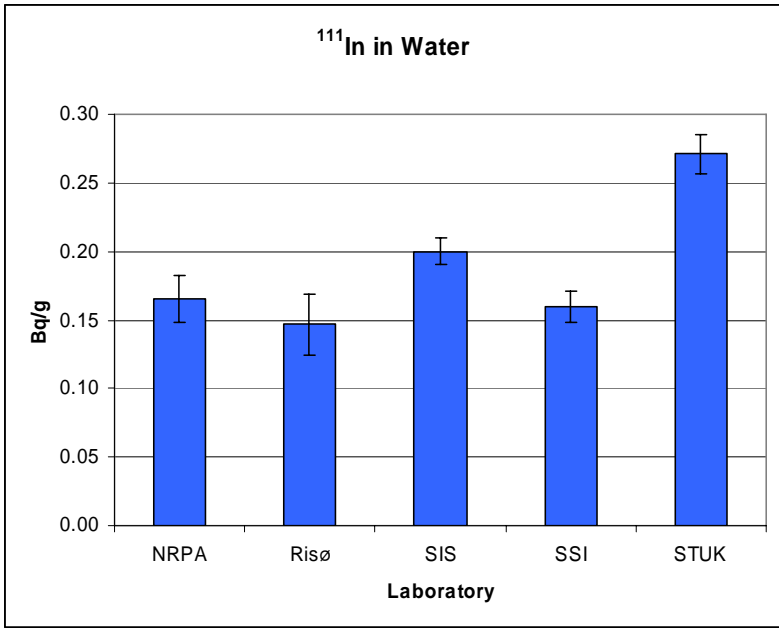

Figure 17. Results on ¹¹¹In in water

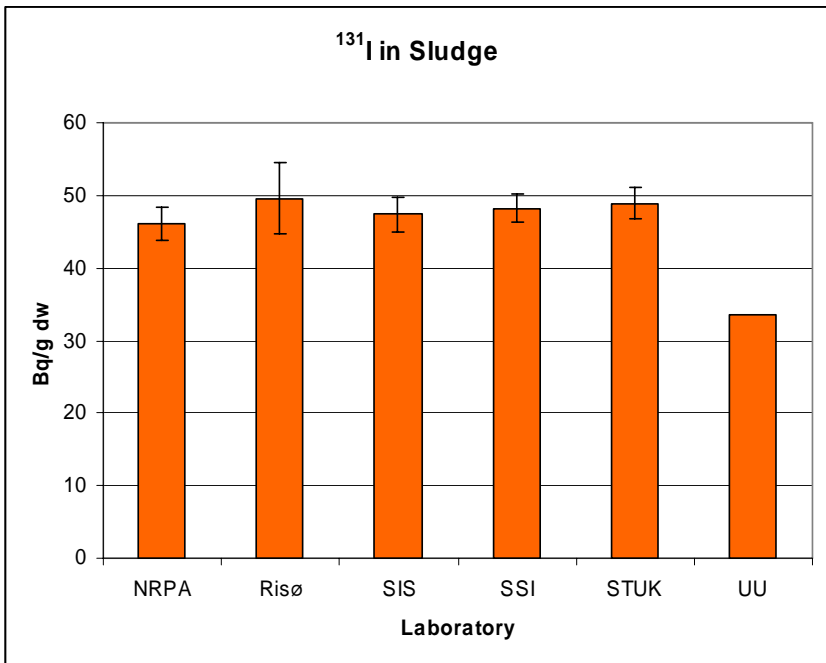

Figure 18. Results on ¹³¹I in sludge.

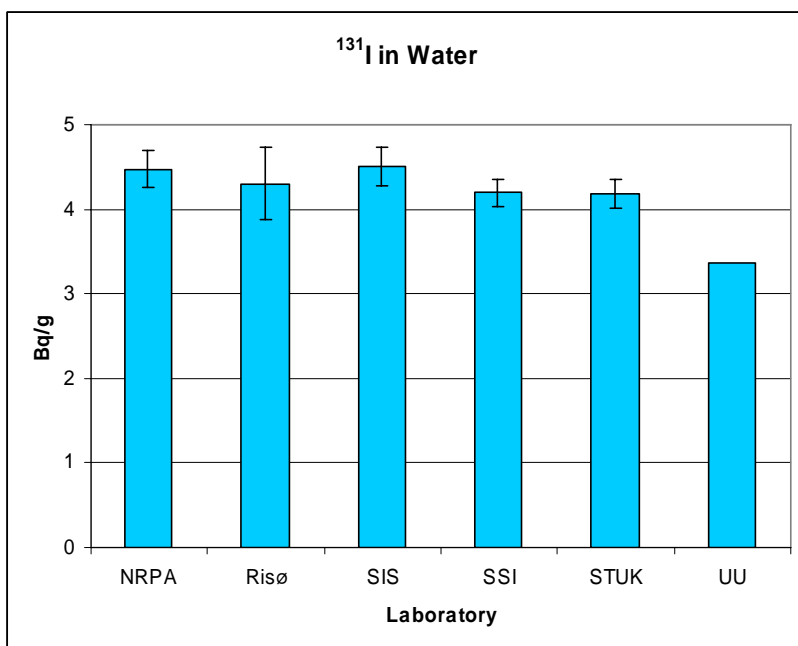

Figure 19. Results on ¹³¹I in water.

7.5 Conclusions

Overall good agreement is found between participants for both sludge and water samples. The agreement between labs for ¹³¹I is relatively better than for ¹¹¹In except for one participant. It should be emphasised that in this case the measurements were performed with a NaI detector.

8 The Lucia model

Although radionuclides are released from hospitals during the whole year, the releases are not continuous and at a constant rate, but occur as pulses lasting few days. This is particularly true for excreta from patients that have received high doses for therapeutic purposes. This means, that a steady state situation with equilibrium radionuclide concentrations may not exist at the sewage plant and therefore to make predictions of the radionuclide concentration in the sludge, a dynamic model is needed. Hence, it was decided to develop such model, the LUCIA model, which is briefly described herein and in more detail in Appendix A. The endpoints of the model are time dependent activity concentrations in water and sludge at the outlet of the plant and after each treatment process.

The LUCIA model was initially developed for the sewage plant *Kungsängsverket* in Uppsala. As the same treatment processes are applied at the sewage plants *Viikinmäki* in Helsinki, and the Aalborg Renseanlæg Vest (ARV) in Denmark; the LUCIA is directly applicable to these plants, although plant specific parameter values should be used. The LUCIA model is also directly applicable to the sewage plant *Skólpa Klettagardar* in Reykjavik, but in a simplified version, as this plant uses the same type of processes for preliminary treatment and primary sedimentation, but not biological treatment is carried out. The sewage plant *VEAS – Vestfjorden avløpselskap* in Oslo uses a different type of biological treatment (Attached Growth Treatment) and therefore a modification of the model is required. In this chapter an overview of the LUCIA model is provided. A more detailed description can be found in Appendix A.

8.1 The conceptual model

A detailed scheme of the technological process used in the *Kungsängsverket* sewage plant is shown in Figure 20. The different treatment steps take place simultaneously in several basins and tanks of different volume. There are three main technological lines, corresponding to different pathways for the incoming water. For the purpose of the model such level of detail is unnecessary and therefore all basins and tanks of the same type were treated as single compartments. This is indicated by the rectangular boxes in Figure 20.

The LUCIA conceptual model is shown schematically in Figure 21. The model consists of 9 compartments, 7 of which correspond to the rectangular boxes in Figure 20: R1, R2, R3, R4, T1, T2 and T3 and two (R1sed and R3sed) additional compartments that correspond to the precipitated sludge in the sedimentation basins (R1 and R3). Each of the 9 compartments represents a state variable with an associated radionuclide inventory as indicated in Table 24, where also the associated plant components are indicated. The final polishing step is described in a more simplified form in the model, where precipitation of sludge is considered to be insignificant in normal conditions and therefore not considered.

The arrows in the conceptual diagram represent the radionuclide fluxes between the different compartments, which are driven by the fluxes of water and sludge in the plant. Most fluxes are in one direction, from the inlet to the outlet of the plant. The only exceptions are the fluxes from the compartments associated with the secondary sedimentation basins (R3 and R3sed) back to the basins for biological treatment. These fluxes correspond to the pumping of a fraction of the secondary sludge into the basins for biological treatment to provide bacterial stock needed for the treatment.

8.1 Assumptions

The model describes the plant as a series of interconnected compartments. A main assumption of this type of models is that the radionuclides and other species, such as water, solid particles and organic material that enter a compartment get instantaneously fully mixed in the compartment. At the same time, it is assumed that the transfer rate of the radionuclides from one compartment to another is proportional to the inventory of radionuclides in the donor compartment.

The model assumes steady state conditions for the wastewater, solids and organic material in the system. This means that, in all compartments, the levels of these species are kept constant in time. If the fluxes of a species into a compartment increase or decrease, then the fluxes out from this compartment will increase or decrease proportionally, so that the levels in the compartments remain constant. This assumption is consistent with the way sewage plants function in normal situations. However, in special conditions, like in case of a storm, it could be that it is not possible to keep constant levels in the basins. Hence, the model cannot be directly applied, without modifications, to such situations. The assumption of steady state does not apply for the radionuclides, which levels are allowed to vary without restrictions. This way the model can be applied to any type of releases, including pulse releases.

Another assumption is that losses of radionuclides from the plant occur only via discharged water and sludge that is transported away from the plant. Although losses to air may occur, especially for volatile radionuclides as I-131, these are conservatively neglected.

Table 24. Compartments in the model, associated plant components and definition of the corresponding state variables.

Compartment	Plant components	State variable
R1	Primary sedimentation basins	Total radionuclide inventory in dissolved

	Water phase	form and absorbed to suspended particles
R1sed	Primary sedimentation basins Precipitated sludge	Radionuclide inventory in the precipitated sludge
R2	Basins for biological treatment	Total radionuclide inventory in dissolved form and absorbed to suspended particles
R3	Secondary sedimentation basins Water phase	Total radionuclide inventory in dissolved form and absorbed to suspended particles
R3sed	Secondary sedimentation basins Precipitated sludge	Radionuclide inventory in the precipitated sludge
R4	Sedimentation basin for final polishing Water phase	Total radionuclide inventory in dissolved form and absorbed to suspended particles
T1	Thickener, sink and silo	Total radionuclide inventory in the components
T2	Digester	Total radionuclide inventory in the digester
T3	Centrifuge and sludge storage	Total radionuclide inventory in the components

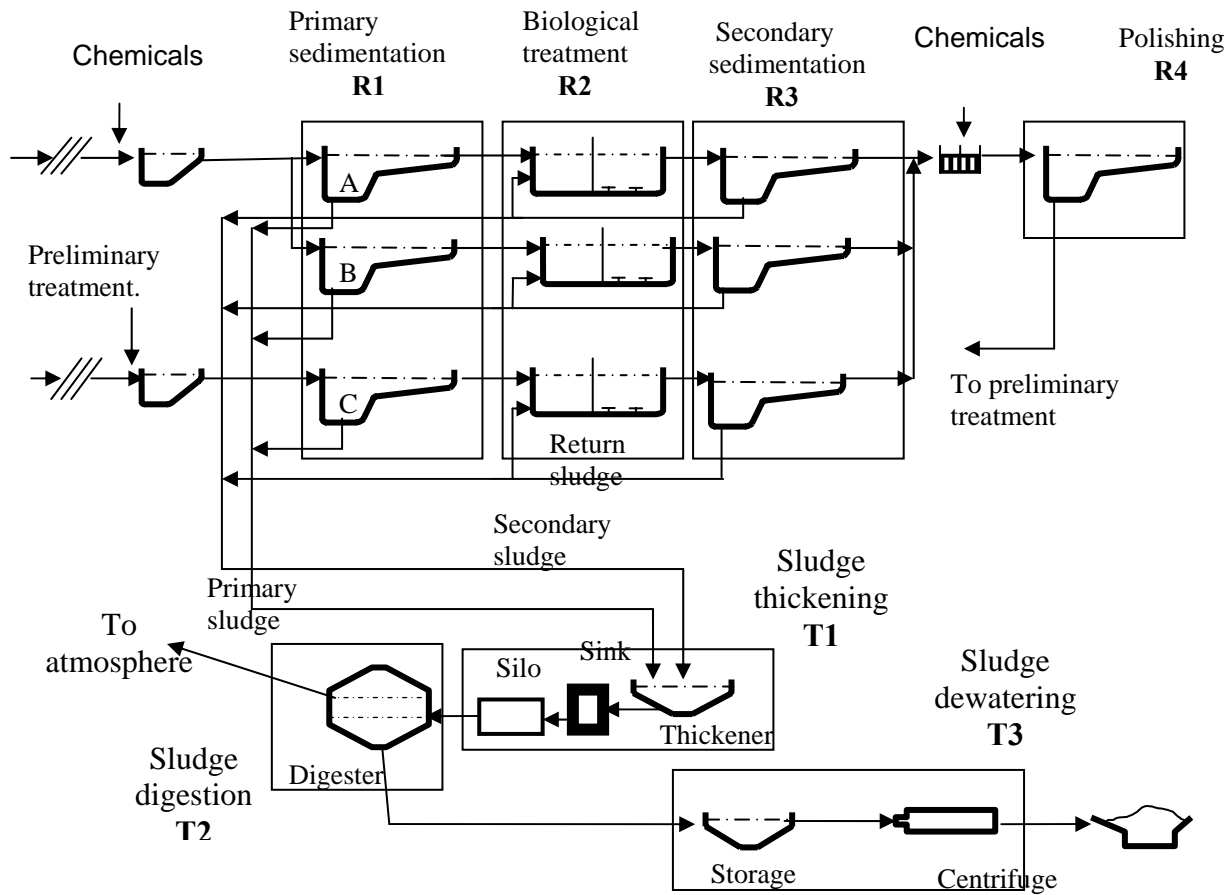

Figure 20. Schematic representation of the technological process at the *Kungsängsverket* sewage plant (Uppsala). The rectangular boxes indicate how the components have been grouped into compartments in the conceptual model.

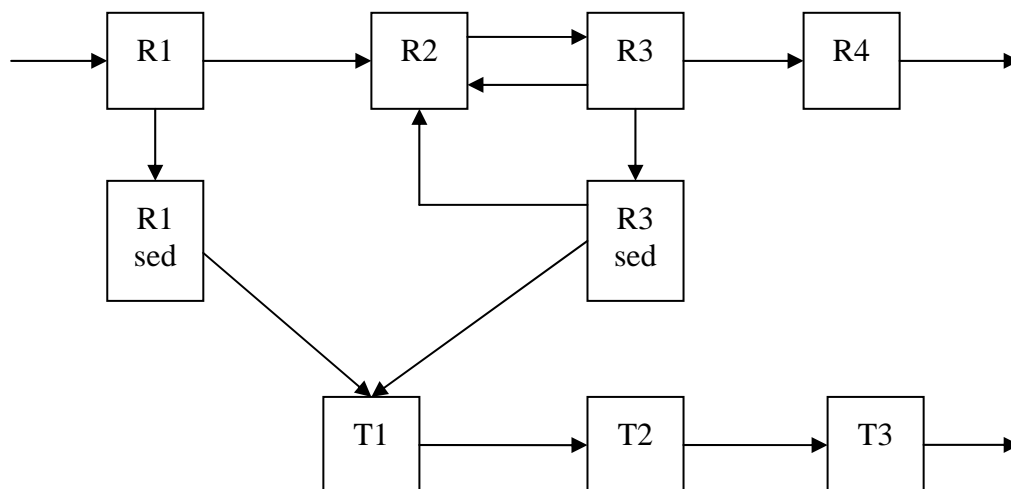

Figure 21 Conceptual representation of the LUCIA model for the Uppsala sewage plant. The boxes correspond to model compartments (see Table 23) and the arrows to radionuclide fluxes between compartments

8.2 Mathematical model and parameters

The LUCIA mathematical model consists of a system of ordinary differential equations (ODE). These represent the mass balance in the different compartments defined in Table 24. The equations used are provided in Appendix A. These allow estimating the concentration of radionuclides in water and sludge depending on the radionuclide concentration in the plant inlet. The model was implemented using the software package Ecolego (from Facilia AB).

Parameters relating to the treatment processes are derived from data measured in the studied sewage plants. The only radionuclide specific parameters required by the model are the distribution coefficients K_{dR1} and K_{dR2} . These represent, for the radionuclides of interest, the distribution coefficients between water and sludge in the compartments R1 and R2, respectively. Their values depend on the concentration of suspended solids and the chemical conditions.

Although an extensive literature review was carried out, distribution coefficients for sludge were not found for any of the elements of interest. Instead, K_d values reported for organic soils were used, which to some extent can be considered as representative for sewage sludge, consisting mainly of organic material. Details of the used values are given in Section A-3 of Appendix A.

8.3 Sensitivity analysis

The sensitivity of the model to variation in the model parameters was studied using the software package Eikos (From Facilia AB). The sensitivity study was carried out for I-131, which is one of the significant radionuclides for the exposure of sewage workers. The studied endpoints were the concentration of I-131 in the digested sludge (T2 in Figure 21) and the efficiency (Eff) of the wastewater treatment, defined as the activity concentration in the water coming into the plant divided by the activity concentration in the water released from the plant.

The results of the sensitivity analysis are presented in Section A-4 of Appendix A. They show that the predictions of the concentration in the digested sludge are highly sensitive to the distribution coefficient for the primary sedimentation (K_{dR1}), slightly sensitive to the distribution coefficient for the biological treatment (K_{dR2}) and practically insensitive to all other model parameters, when

considered individually. The same is valid for the efficiency of the wastewater treatment, but this endpoint was also highly sensitive to the water flux Q , since this parameter determines the residence time of the I-131 in the wastewater treatment plant.

The contribution of the model parameters to the variance of the predictions was estimated using Total Sensitivity Indexes calculated with the Extended Fourier Amplitude Sensitivity Test, EFAST (available in Eikos). This method takes into account interactions between parameters. The obtained results indicate that 46 % of the variance in the predictions of the concentrations in digested sludge is explained by the variance of the K_dR1 and the rest by other parameters, but no single parameter contributes with more than 6 %.

These results from the sensitivity analysis lead to the important conclusion that reasonable values for the distributions coefficients and for the water flux are primarily required in order to arrive at realistic exposure doses.

9 A modelling study using process orientated activated sludge model

9.1 Introduction

The screening calculation methodology proposed by IAEA (2001) to estimate the subsequent radiation doses from a radionuclide release to a wastewater treatment plant has two extreme scenarios, i.e., all the radionuclides are adsorbed to the sludge produced at the wastewater plant or all the radionuclides pass through the plant to the final water recipient. Based on the philosophy of the IAEA guidance (IAEA 2001) the screening calculations start with the over conservative recommendations and gradually to the conservative but more “realistic” assumptions if the exception condition can not be fulfilled. The screening study made by Avila et al., (2007) showed that realistic assessments are needed to predict the doses to sewage workers.

The LUCIA mode developed for this purpose is a dynamic model and is able to estimate the distribution of the radionuclides between the discharged water and the sludge in a more realistic manner. However, the model requires not only the generic knowledge of the plants such as data for influent and effluent as well as the dimensions of the plant but information about treatment efficiency for each treatment step, which might not always be available. To reduce the requirement of the details of the information a process orientated model is proposed here. The model is a combination of a simplified well known Activated Sludge Model No.1 (Henze, 1987) and K_d concept used in LUCIA model. The model is able to estimate the concentrations and the retention time of the sludge in different parts of the treatment plant, which in turn, can be used as a tool for the dose assessment purpose.

9.2 Proposed models

9.2.1 Simplified activated sludge model

To estimate the distribution of radionuclide between the discharged water and the sludge in a treatment plant the determination of sludge production is essential. The best known and widely spread model of wastewater treatment was presented in 1987 as the IAWQ Activated Sludge Model No. 1. (Henze et al., 1987). We simplify this model by excluding processes such as nitrification and denitrification. This is done because these processes do not contribute largely to the sludge production. The simple Monod-Herbert equation is employed in the “Model No.1” to express the reactions between the biomass and the substrates. For instance, the Monod equation says that the growth of biomass is proportional to biomass concentration in a first order manner and substrate concentration in

a mixed order manner. The Herbert expression states that biomass decay is first order with respect to biomass concentration. The corresponding variables are reduced from 13 (used in Model No.1) to 6. The variables in the model are based on organic matter, measured in COD-units (Chemical Oxygen Demand). The simplified activated sludge model consists of several reactions described by a set of differential equations shown as the following:

$$\begin{aligned} \frac{dS_S^i}{dt} = & -\hat{\mu}_H \left(\frac{S_S^i}{K_S + S_S^i} \right) \left(\frac{S_O^i}{K_{O,H} + S_O^i} \right) X_{B,H}^i + k_h \frac{X_S^i / X_{B,H}^i}{K_X + X_S^i / X_{B,H}^i} \frac{S_O^i}{K_{O,H} + S_O^i} X_{B,H}^i \\ & - \frac{1-Y_H}{Y_H} \hat{\mu}_H \left(\frac{S_S^i}{K_S + S_S^i} \right) \left(\frac{S_O^i}{K_{O,H} + S_O^i} \right) X_{B,H}^i + IN_{S_S} - S_S^i Q/V^i \end{aligned} \quad (1)$$

$$\frac{dX_{B,H}^i}{dt} = \hat{\mu}_H \left(\frac{S_S^i}{K_S + S_S^i} \right) \left(\frac{S_O^i}{K_{O,H} + S_O^i} \right) X_{B,H}^i - b_h X_{B,H}^i + IN_{X_{BH}} - X_{B,H}^i Q/V^i \quad (2)$$

$$\frac{dX_S^i}{dt} = b_h X_{B,H}^i - k_h \frac{X_S^i / X_{B,H}^i}{K_X + X_S^i / X_{B,H}^i} \frac{S_O^i}{K_{O,H} + S_O^i} X_{B,H}^i + IN_{X_S} - X_S^i Q/V^i \quad (3)$$

$$\frac{dS_O^i}{dt} = -\frac{1-Y_H}{Y_H} \hat{\mu}_H \left(\frac{S_S^i}{K_S + S_S^i} \right) \left(\frac{S_O^i}{K_{O,H} + S_O^i} \right) X_{B,H}^i + IN_{S_O} - S_O^i Q/V^i \quad (4)$$

$$\frac{dX_I^i}{dt} = IN_{X_I} - X_I^i Q/V^i \quad (5)$$

$$\frac{dS_I^i}{dt} = IN_{S_I} - S_I^i Q/V^i \quad (6)$$

where

S_S = readily biodegradable substrate concentration in reactor/compartment i [kg COD/m³]

S_I = soluble, inert organic matter concentration in reactor/compartment i [kg COD/m³]

$X_{B,H}$ = active heterotrophic biomass concentration in reactor/compartment i [kg COD/m³]

X_S = particulate, slowly biodegradable substrate concentration in reactor/compartment i [kg COD/m³]

X_I = particulate, inert organic matter concentration in reactor/compartment i [kg COD/m³]

S_O = oxygen concentration in reactor/compartment i [kg COD/m³]

Q = Influent flow [m³/h]

V = volume of reactor/compartment i [m³]

IN_x = input source of various substrate x [kg COD/m³/h]

The relationship between sludge, i.e. suspended solids, SS and COD can be expressed as:

$$SS = (X_I + X_S + X_{BH})/CF_{COD} + SS_{inorg} \quad (7)$$

Where CF_{COD} is the conversion factor which is 1.12 according to Xu and Hultman (1997).

Since there is no data about SS_{inorg} in the influent and it is usually low, we assume that SS_{inorg} can be neglected in the calculations.

9.2.2 K_d concept

Once the sludge concentration is determined the distribution of the radionuclides between the water and the sludge can be easily estimated by the K_d concept (Avila et al., 2007). The K_d is defined as the ratio between the radionuclide concentration in solids, expressed in [Bq/kg DW] and the radionuclide concentration in water, expressed in [Bq/m³]. The unit of the K_d is then [m³/kg].

The total inventory (A_{total}) of radionuclides in a reactor will be:

$$A_{total} = Conc_{sludge} M_{sludge} + Conc_{water} V_{water} \quad (8)$$

Dividing by the water volume (V_{water}) and introducing the K_d gives:

$$\frac{A_{total}}{V_{water}} = Conc_{water} (K_d SS + 1) \quad (9)$$

Where

$Conc_{water}$ = radionuclide concentration in the water phase [Bq/m³]

$Conc_{sludge}$ = radionuclide concentration in the solid phase [Bq/m³]

V_{water} = water volume of the reactor [m³]

M_{sludge} = mass of the solid/sludge in the reactor [kg]

9.2.3 Wastewater compositions

The compositions of various substrates in the influent are the boundary conditions to solve the simplified activated sludge model for estimating the sludge production. This is the main difference between the proposed model and the LUCIA model. The composition of the substrates can be determined by the total COD concentration in the influent and effluent at each treatment plant because these COD values are available from the routine measurements. Substrates defined by COD unit in the influent consist of the following parts:

$$COD_{in} = S_I + S_S + X_I + X_S + X_{BH} \quad (10)$$

where

S_I = concentration of soluble, inert organic matter [kg COD/m³]

S_S = concentration of readily biodegradable substrate [kg COD/m³]

X_I = concentration of particulate, inert organic matter [kg COD/m³]

X_S = concentration of particulate, slowly biodegradable substrate [kg COD/m³]

X_{BH} = concentration of active heterotrophic biomass [kg COD/m³]

Since waste water passes through a rather long treatment process in the treatment plant such as chemical precipitation and biological treatment, the COD in the effluent is known as un-biodegradable substrate, which is thought to be inert organic matter, S_I . Thus, an estimation of various fractions of COD in the influent is based on the difference between total COD in the influent and COD in the effluent. The determination of the fractions is not critical in this case because we are only interested in the sludge production not the details of the reactions between the biomass and the substrates. A default distribution of various fractions based on the statistics of the long time series data from Uppsala WWPT is expressed as the following:

$$X_I = 0.25(COD_{IN} - COD_{OUT}) \quad (11)$$

$$X_S = 0.38(COD_{IN} - COD_{OUT}) \quad (12)$$

$$S_S = 0.32(COD_{IN} - COD_{OUT}) \quad (13)$$

$$X_{BH} = 0.05(COD_{IN} - COD_{OUT}) \quad (14)$$

$$S_i = COD_{OUT} \quad (15)$$

9.2.4 Sedimentation processes

Except the biological treatment processes there are chemical pre-sedimentation and physical secondary sedimentation processes. Pre-sedimentation in our model will be represented by a simple reduction rate (Karlsson and Smith, 1991), F_{RED} . Since the soluble, inert organic matter might not be affected by the pre-sedimentation process the reduction of organic matter in the wastewater is expressed by

$$Reduction = (COD_{IN} - COD_{OUT}) \times F_{RED} \quad (16)$$

Secondary sedimentation is treated as an ideal sedimentation basin, which means that all the sludge will be returned to the biological treatment reactor except the excess sludge and the suspended solids in the effluent. The suspended solids in the effluent are thought to be flow-proportional and is described by an empirical model as the following (EFOR, 1993);

$$SS_{out} = SS_{init} + k_1 (Q_{out}/A)^{k_2} \quad (17)$$

where

SS_{out} concentration of suspended solids in the effluent [mg/l]

SS_{init} initial concentration of suspended solids [mg/l]

Q_{out} the flux [m^3/day]

A area of sedimentation basin [m^2]

k_1, k_2 parameters used in settling velocity functions

9.2.5 Simulation results

The simplified activated sludge model has been tested by using the data obtained from the Uppsala WWTP. Figure 22 shows the schematic description of the treatment processes at the Uppsala WWTP. The flow and COD data from April of 2003 to April 2005 were used in the test (see Fig. 23). Parameter values used in the model are listed in Table 25. Values related to the design and operational parameters for the Uppsala WWTP are shown in Table 26. The model was implemented in the numerical software Ecolego (Avila et al., 2000). Figure 24 to 26 shows the simulated COD concentration in the effluent, the sludge concentrations after the pre-sedimentation and the thickening tanks as well as the corresponding measuring data. As it can be seen the simulated results fit the measured data fairly well without great efforts on calibration. The reason might be the production of the sludge is highly correlated to the amount of COD removed from the plant.

The model was tested by a pulse release of ^{177}Lu from the hospital. The data was obtained from a measuring campaign at the Uppsala WWTP at the influent during the 18th to 19th,

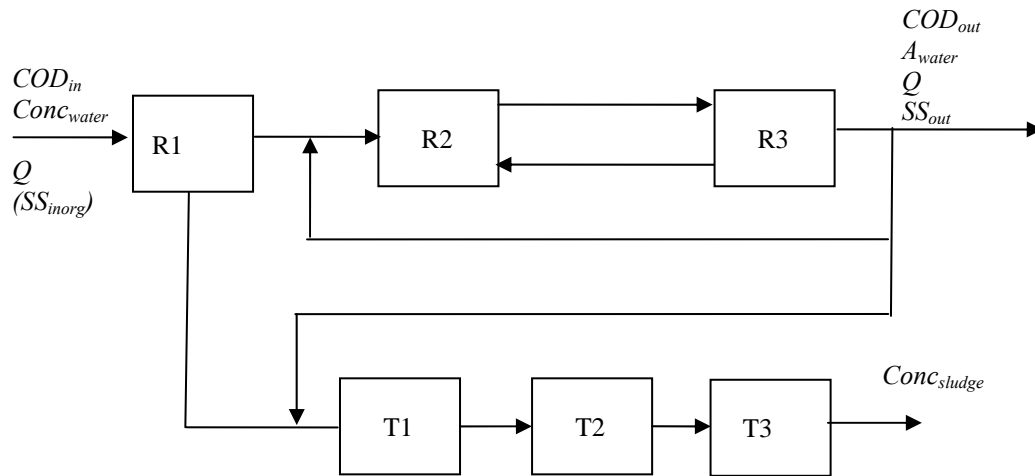

Figure 22. A schematically description of the treatment processes at the Uppsala WWTP, in which R1 is the pre-sedimentation reactor, R2 and R3 are the biological treatment reactors, T1 is the thickening tank, T2 is the digester and T3 is the centrifuge and sludge storage

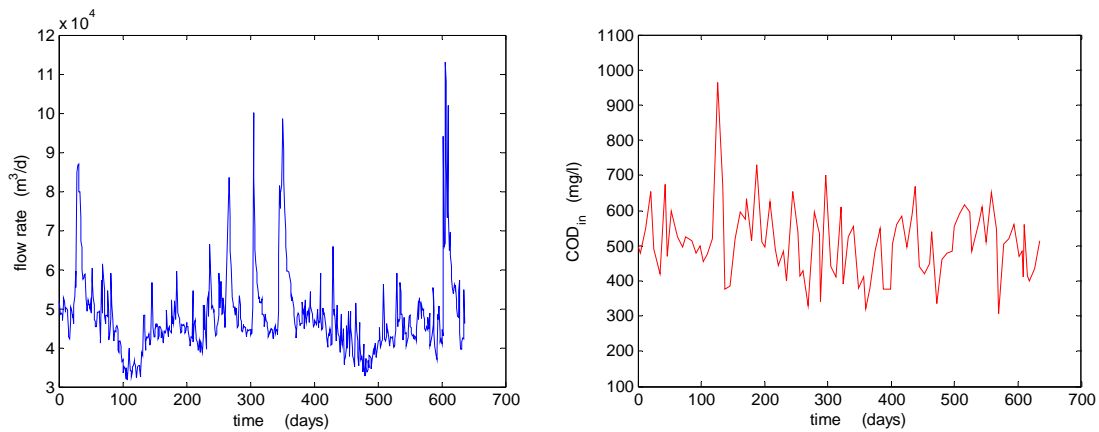

Figure 23. The inflow rate and the COD concentration in the influent to the Uppsala WWTP.

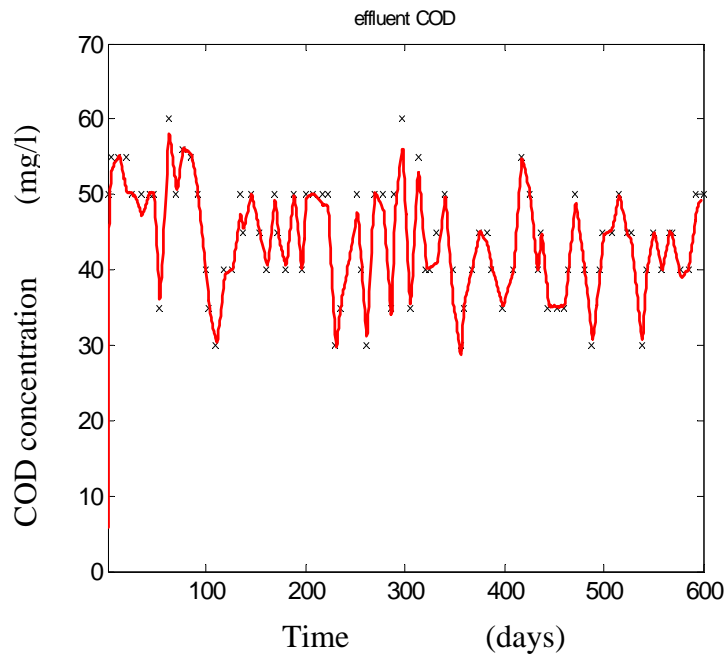

Figure 24. The simulated COD concentration (red solid line) in the effluent compared with measured COD concentration (marked as 'x') in the effluent

Table 25. Default values for the simplified activated sludge model

Parameter		Value	Unit
u_H	maximum specific growth rate for heterotrophs	0,167	1/day
K_S	half saturation coefficient for heterotrophic organisms	20	g COD/m ³
$K_{O,H}$	oxygen half-saturation coefficient for heterotrophs	0,20	g O ₂ /m ³
K_X	half saturation coefficient for hydrolysis of slowly biodegradable substrate	0,03	g cell slowly biodeg./g cell COD
Y_H	yield coefficient for heterotrophic organisms	3,0	g cell slowly biodeg./(g cell COD x day)
k_h	maximum specific hydrolysis rate	0,67	g cell formed/g cell oxidized
$b_{h\cdot}$	maximum specific growth rate for heterotrophs	0,62	1/day
$K1$	coefficient	25	
$K2$	coefficient	2,2	

Table 26. Design and operational parameters for Uppsala WWTP

	Parameter in model	Unit	Value
Area secondary sedimentation	A	m ²	6 260
Average wastewater flow	Q	m ³	47 937
Reduction of SS in pre-sedimentation	RedF	%	55
Oxygen concentration in the inflow	Soin	mg/l	6
Sludge retention time in ASP	SRT	days	10
Volume of AS basin/2	VPred	m ³	15 650
Volume of AS basin/2	Vsed	m ³	15 650
Concentration of SS in effluent	SSinit	mg/l	5

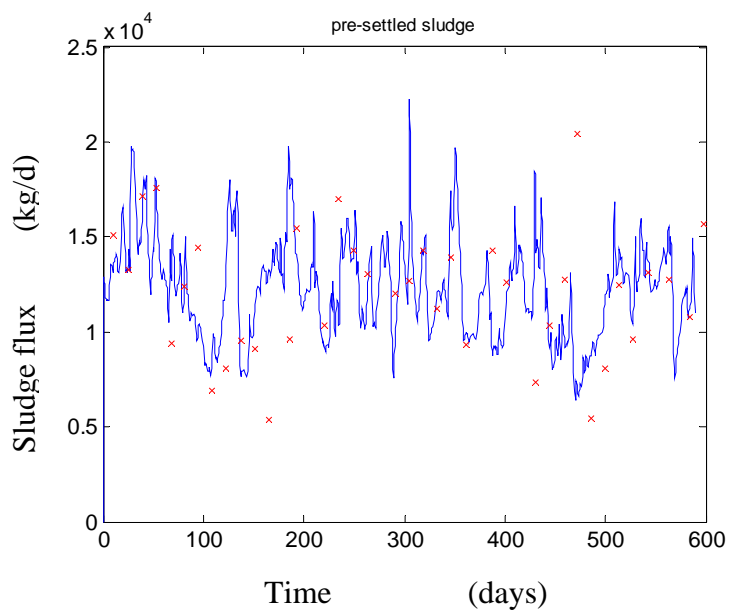

Figure 25. The simulated sludge flux after the pre-sedimentation tank (blue solid line) compared with the measured sludge flux (marked as 'x').

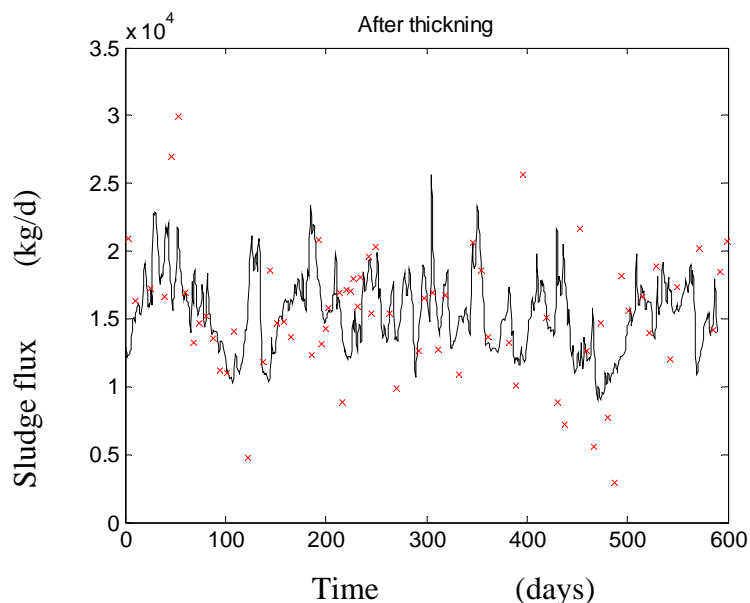

Figure 26. The simulated sludge flux from the thickening tank (black solid line) compared with the measured sludge flux (marked as 'x')

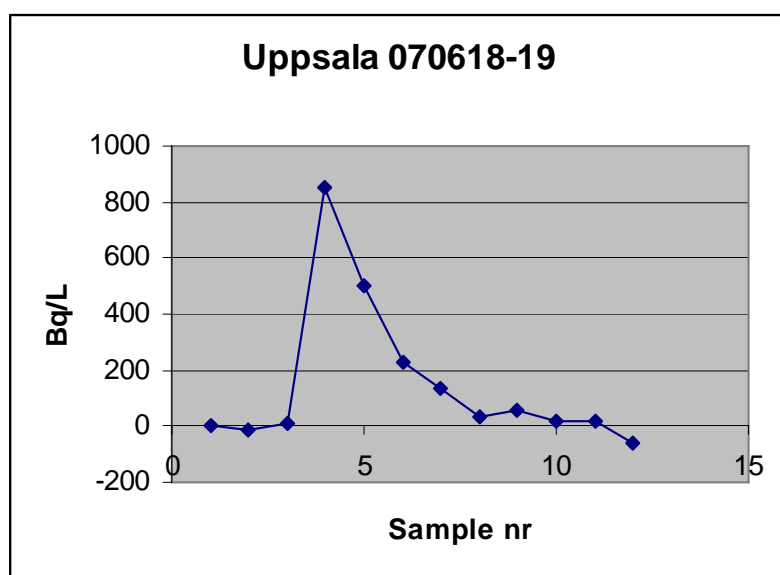

Figure 27. The measured pulse release of ^{177}Lu in the influent of the Uppsala WWPT

June 2007 (see Fig. 27). However, there are neither K_d values available for ^{177}Lu nor complete measured data available at the discharge points to calibrate the model. Nevertheless, we use an assumed K_d value to examine the response of the pulse release to the plant. Figures 28 and 29 show the concentration of ^{177}Lu in the effluent and the dried sludge, respectively. The main difference is the retention time of ^{177}Lu in the sludge compared with that in the effluent. The retention time of ^{177}Lu in the sludge is about 30 days while the retention time of ^{177}Lu is only a few days. This is quite obvious because the retention time of ^{177}Lu is largely correlated to the retention time of sludge and water. The sludge retention time is much longer than the water retention time in the plant.

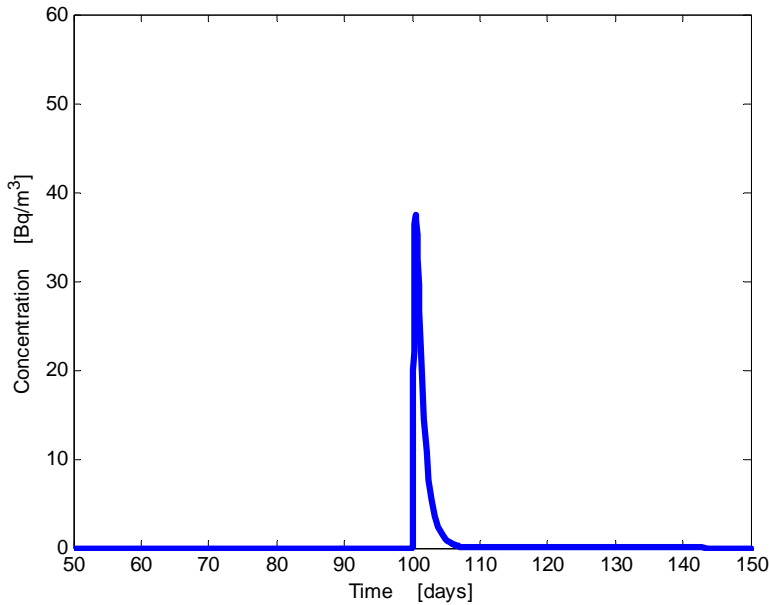

Figure 28. The simulated response of ^{177}Lu concentration in the effluent due to a pulse release of ^{177}Lu to the plant

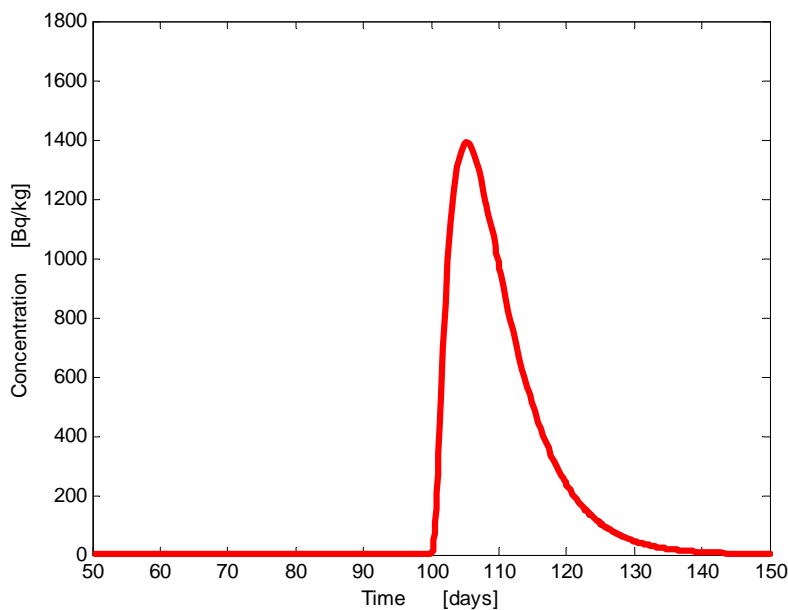

Figure 29. The simulated response of ^{177}Lu concentration in the dried sludge due to a pulse release of ^{177}Lu to the plant.

9.3 Summary

This study shows that the simplified activated sludge model is relatively easy implemented in Ecolego and model calibration is simple too because a number of uncertainties are reduced. The advantages of using the proposed model comparing with LUCIA model is that no specific information such as treatment efficiency for each treatment step is required if WWTP uses an activated sludge process for waste treatment. In this sense the proposed model is more general as a tool for the dose assessment purpose. The knowledge of K_d values is needed in order to estimate the distribution of radionuclides

in the sludge and discharge water. A well planned sampling strategy to assess the completeness of the measurement is the basis for further modelling studies.

10 Dose assessments

Doses resulting from routine releases of Tc-99m and I-131 from hospitals into each of the study sewage plants were calculated using the methodology described briefly below and in more detail in Avila *et al.* (2007). The doses were calculated for hypothetical individuals representing potentially exposed members of the public, including: i) sewage workers, ii) individuals potentially exposed to the water released from the sewage plants and iii) individuals potentially exposed to contaminated sewage sludge that is used for fertilization of agricultural lands.

The dose estimations are based on radionuclide concentrations in water and sludge calculated using the LUCIA model (see Chapter 8). The parameter values used in the LUCIA model are given in Table 1 for each studied sewage plant. If the parameter values were not available for a given plant, then the corresponding values for the Swedish plant were used. Note that most studied plants, with exception to the one in Norway, are very similar to the Swedish plant. The annual release rates of radionuclides that were used, as inputs to the LUCIA model, for calculating radionuclide concentrations in water and sludge, are presented in Table 27. The calculations of radionuclide concentrations and doses were performed using the software-package Ecolego (Avila *et al.* 2003).

Table 27. Estimated annual release rates of I-131 and Tc-99m to the studied sewage plants.

Country		Sweden	Finland	Norway	Denmark	Iceland
Sewage plant		Kungsängverket	Viikinmäki	VEAS Vestfjorden avløpsselskap	Renseanlaeg Vest	Skólpa Klettagardar
Release rate, Bq/y	I-131	1.3E+11 ¹	7.3E+11 ²	9.0E+11 ³	2.2E+11 ⁴	1.9E+11 ⁵
	Tc-99m	1.4E+12 ¹	2.4E+12 ²	7.5E+12 ³	-	-

¹ Taken from Avila *et al.* (2007)

² Activity administered to patients that was discharged into Viikinmäki in 2003

³ Estimated activity that might be released during the whole year, assuming that 37 GBq of I-131 is administered every two weeks.

⁴ Estimated activity that might be released during a year, assuming that 35 GBq of I-131 is administered every two months .

⁵ Annual use of I-131, according to provided information

10.1 Pathways

WATER PATHWAY

Doses to a hypothetical individual that drinks water from the final recipient of the sewage discharges and eats fish living in this aquifer were estimated. The activity concentrations in the final recipient were conservatively assumed to equal the activity concentrations at the discharge point from the plant, i.e. dilution in the final recipient was neglected.

Doses from ingestion of water and fish were obtained by multiplying the radionuclide activity concentrations in water and fish (see equations 1 and 2) with the corresponding consumption rates (Table 29) and the dose factor for ingestion (Table 30).

$$Dose_{water}^j = C_{water}^j * IR_{water} * DF_{ing}^j \quad (1)$$

$$Dose_{fish}^j = C_{fish}^j * IR_{fish} * DF_{ing}^j \quad (2)$$

where,

$Dose_{water}^j$ is the annual dose from the j -th radionuclide via water ingestion [Sv/a],

$Dose_{fish}^j$ is the annual dose from the j -th radionuclide via fish ingestion [Sv/a],

C_{water}^j is the activity concentration of the j -th radionuclide in the water discharged from the sewage plant [Bq/m³],

C_{fish}^j is the activity concentration of the j -th radionuclide in fish [Bq/kg FW],

IR_{water} is the consumption rate of water [m³/y],

IR_{fish} is the consumption rate of fish [kg FW/y],

DF_{ing}^j is the j -th radionuclide dose factor for ingestion [Sv/Bq].

The activity concentrations in fish were calculated by multiplying the activity concentration in water by a bioaccumulation factor (values for freshwater fish provided in Table 28).

$$C_{fish}^j = C_{water}^j * BF^j \quad (3)$$

where:

C_{fish}^j is the activity concentration of the j -th radionuclide in fish [Bq/kg FW],

C_{water}^j is the activity concentration of the j -th radionuclide in the water discharged from the sewage plant [Bq/m³],

BF^j is the bioaccumulation factor in fish for the j -th radionuclide [Bq/kg FW per Bq/m³].

SLUDGE PATHWAY

Doses to sewage workers and to a hypothetical farmer that uses sludge for fertilization of agricultural land were calculated using the methods described below.

Doses to sewage workers

The most important exposure pathways of sewage workers from radionuclides in the sludge are external irradiation and inhalation of re-suspended material (IAEA, 2001). The following equations were used in the calculations of external and inhalation doses:

$$Dose_{ext}^j = C_{sludge}^j * \rho * ConvF * OF * DF_{ext}^j \quad (4)$$

where:

$Dose_{ext}^j$ is the external radiation dose from the sewage sludge for the j -th radionuclide [Sv/a]

C_{sludge}^j is the activity concentration of the j -th radionuclide in the sludge [Bq/kg DW],

ρ is the density of sewage sludge [kg WW/m³],

$ConvF$ is a conversion factor between dry weight and wet weight of sludge [kg DW/kg WW],

OF is the fraction of the year during which exposure occurs [dimensionless].

DF_{ext}^j is the dose factor for external exposure [Sv/a per Bq/m³].

$$Dose_{inh}^j = C_{sludge}^j * RF * ConvF * OF * InhR * DF_{inh}^j \quad (5)$$

where:

$Dose_{inh}^j$ is the annual dose from inhalation of the j -th radionuclide with resuspended sewage sludge [Sv/a]

C_{sludge}^j is the activity concentration of the j -th radionuclide in the sludge [Bq/kg DW],

RF is the concentration of resuspended particles in air [kgWW/m³],

$ConvF$ is a conversion factor between dry weight and wet weight [kg DW/kg WW],

OF is the fraction of the year during which exposure occurs [dimensionless],

$InhR$ is the annual inhalation rate [m³/a],

DF_{inh}^j is the dose factor for intake by inhalation [Sv/Bq].

Parameters values used in the calculations of doses to sewage workers are given in Table 32.

Doses to a hypothetical farmer

For the hypothetical farmer the following doses were calculated: external doses, inhalation doses and doses from ingestion of crops, meat and milk that are produced in a hypothetical agricultural land where contaminated sludge has been used as fertilizer.

Doses from the consumption of food were calculated by multiplying the activity concentrations in crops (equation 9), milk (equation 11) and meat (equation 12) with the consumption rates of each type of food (Table 28) and the dose factor for ingestion (Table 29).

$$Dose_{crop}^j = C_{crop}^j * IR_{crop} * DF_{ing}^j \quad (6)$$

$$Dose_{milk}^j = C_{milk}^j * IR_{milk} * DF_{ing}^j \quad (7)$$

$$Dose_{meat}^j = C_{meat}^j * IR_{meat} * DF_{ing}^j \quad (8)$$

where:

$Dose_{crop}^j$ is the annual effective dose of the j -th radionuclide from consumption of crops [Sv/a],

$Dose_{milk}^j$ is the annual effective dose of the j -th radionuclide from consumption of cow milk [Sv/a],

$Dose_{meat}^j$ is the annual effective dose of the j -th radionuclide from consumption of cow meat [Sv/a],

C_{crop}^j is the concentration factor for uptake of the j -th radionuclide from soil by edible parts of crops [Bq/kg FW per Bq/kg DW],

C_{milk}^j is the activity concentration of the j -th radionuclide in milk [Bq/l],

C_{meat}^j is the activity concentration of the j -th radionuclide in cow meat [Bq/kg FW],

IR_{crop} is the consumption rate of crops [kg FW/y],

IR_{milk} is the consumption rate of cow milk [L/y],

IR_{meat} is the consumption rate of cow meat [kg FW/y],

DF_{ing}^j is the j -th radionuclide dose factor for ingestion [Sv/Bq].

The activity concentration in crops and animal feed were calculated by multiplying the activity concentrations in sewage sludge with the appropriate transfer factors (Table 29) and correction coefficients (Table 31).

$$C_{crops}^j = C_{sludge}^j * CF_{crops}^j * \exp(-\lambda^j * T_{crops}) * fred \quad (9)$$

where:

C_{crops}^j is the activity concentration of the j -th radionuclide in crops at the time of consumption by humans [Bq/kg FW],

C_{sludge}^j is the activity concentration of the j -th radionuclide in the sludge [Bq/kg DW],

CF_{crops}^j is the concentration factor for uptake of the j -th radionuclide from soil by edible parts of crops [Bq/kg FW per Bq/kg DW],

T_{crops} is the time period between harvest and consumption of the crops [days],

λ^j is the j -th radionuclide decay constant [1/days],

$fred$ is the reduction factor (see equation 13).

$$C_{Feed}^j = C_{sludge}^j * CF_{pasture}^j * (f_p + (1 - f_p) * \exp(-\lambda^j * T_{StFeed})) * fred \quad (10)$$

where:

C_{Feed}^j is the activity concentration of the j -th radionuclide in animal feed [Bq/kg DW],

C_{sludge}^j is the activity concentration of the j -th radionuclide in the sewage sludge [Bq/kg DW],

$CF_{pasture}^j$ is the concentration factor for uptake of the j -th radionuclide from soil by pasture [Bq/kg DW per Bq/kg DW],

f_p is the fraction of the year that animals consume fresh pasture vegetation [dimensionless],

T_{StFeed} is the time period between harvest of pasture and consumption of storage feed [days],

λ^j is the j -th radionuclide decay constant [1/days].

$fred$ is the reduction factor (see equation 13).

The activity concentrations in milk and meat at the time of consumption by humans were calculated with the following equations.

$$C_{milk}^j = C_{Feed}^j * F_{milk}^j * DMI_{milk} * \exp(-\lambda^j * T_{milk}) \quad (11)$$

where:

C_{milk}^j is the activity concentration of the j -th radionuclide in milk [Bq/l],

C_{Feed}^j is the activity concentration of the j -th radionuclide in animal feed [Bq/kg DW],

F_{milk}^j is the fraction of animal's daily intake of the j -th radionuclide that appears in each litre of milk at equilibrium [d/l],

DMI_{milk} is the amount of feed (in dry matter) consumed by milk producing cows [kg DW/day],

T_{milk} is the average time between collection and human consumption of fresh milk [day],

λ^j is the j -th radionuclide decay constant [1/day].

$$C_{meat}^j = C_{Feed}^j * F_{meat}^j * DMI_{meat} * \exp(-\lambda^j * T_{meat}) \quad (12)$$

where:

C_{meat}^j is the activity concentration of the j -th radionuclide in cow meat [Bq/kg FW],

C_{Feed}^j is the activity concentration of the j -th radionuclide in animal feed [Bq/kg DW],

F_{meat}^j is the fraction of animal's daily intake of the j -th radionuclide that appears in each kg of cow meat at equilibrium or at the time of slaughter [day/kg FW],

DMI_{meat} is the amount of feed (in dry matter) consumed by meat producing cows [kg DW/day],

T_{meat} is the average time between slaughter and human consumption of cow meat [day].

External doses to the farmer were calculated with the following equation:

$$Dose_{farmer,ext}^j = C_{sludge}^j * \rho * ConvF * OF * DF_{ext}^j * f_{red} * \frac{(1 - \exp(-\lambda^j * T_{exp}))}{\lambda^j * T_{exp}} \quad (13)$$

where:

$Dose_{farmere,xt}^j$ is the external radiation dose for the farmer for the j -th radionuclide [Sv/a],

f_{red} is a dimensionless reduction factor to take account the dilution of sludge with uncontaminated soil (see below) ,

T_{exp} is the total time within the year when exposure can take place, chosen as 365 days.

C_{sludge}^j is the activity concentration of the j -th radionuclide in the sludge [Bq/kg DW],

ρ is the density of the sewage sludge mixed with soil, assumed here equal to the density of the sludge [kg WW/m³],

$ConvF$ is a conversion factor between dry weight and wet weight of sludge [kg DW/kg WW],

OF is the fraction of the year during which exposure of the farmer occurs [dimensionless].

DF_{ext}^j is the dose factor for external exposure [Sv/a per Bq/m³].

The doses to the farmer from inhalation were calculated with the following equation:

$$Dose_{farmer,inh}^j = C_{sludge}^j * RF * ConvF * OF * InhR * DF_{inh}^j * f_{red} * \frac{(1 - \exp(-\lambda^j * T_{exp}))}{\lambda^j * T_{exp}} \quad (14)$$

where:

$Dose_{farmer,inh}^j$ is the inhalation dose for the farmer for the j -th radionuclide [Sv/a],

f_{red} is a dimensionless reduction factor to take account the dilution of sludge with uncontaminated soil (see below),

T_{exp} is the total time within the year when exposure can take place, chosen as 365 days.

C_{sludge}^j is the activity concentration of the j -th radionuclide in the sludge [Bq/kg DW],

ρ is the density of the sewage sludge mixed with soil, assumed here equal to the density of the sludge [kg WW/m³],

$ConvF$ is a conversion factor between dry weight and wet weight of sludge [kg DW/kg WW],

OF is the fraction of the year during which exposure of the farmer occurs [dimensionless].

RF is the concentration of resuspended particles in air [kgWW/m³],

DF_{inh}^j is the dose factor for intake by inhalation [Sv/Bq].

The exponential factor in equations (13) and (14) takes into account the fact that the sludge is added only once a year on the agricultural land and that the radioactive decay will occur

during the whole external exposure period of one year. This is different from the exposure of the sewage plant worker, who is exposed to fresh sludge on a relatively continuous basis.

The reduction factor f_{red} in equations (13) and (14) takes into account the fact that sludge is only present on a thin layer on the agricultural land as opposed to their deposition in heaps in the sewage plant. This factor was chosen as $f_{red} = 0.03$, *i.e.* it is assumed that 3 % of the upper soil layer, which contributes to the external exposure to the farmer, is comprised of sludge.

Since sludge is only added in thin layers to agricultural lands, this assumption is seen as sufficiently conservative (Avila, 2007).

10.2 Parameter values

The parameter values used in the dose calculations are presented in Tables 28 to 32.

Table 28. Element specific transfer factors used in the calculations (IAEA, 2001).

Element	¹ BF^j	² CF_{crops}^j	³ $CF_{pasture}^j$	⁴ F_{milk}^j	⁵ F_{meat}^j
I	4,0E-02	2,0E-02	1,0E-01	1,0E-02	5,0E-02
Tc	2,0E-02	5,0E+00	8,0E+01	1,0E-03	1,0E-03

¹ Bioaccumulation factor for fish (BF in Bq/kg FW per Bq/m³)

² Concentration Factor for crops (CF_{crops} in Bq/kg FW per Bq/kg DW)

³ Concentration Factor for pasture ($CF_{pasture}$ in Bq/kg DW per Bq/kg DW)

⁴ Transfer Factor to milk (F_{milk} in d/L)

⁵ Transfer Factor to meat (F_{meat} in d/kg FW)

Table 29. Consumption rates used in the dose calculations (IAEA, 2001).

	Units	Value
Water, IR_{water}	m ³ /y	0.6
Freshwater fish, IR_{fish}	kg FW/y	30
Crops, IR_{crops}	kg FW/y	410
Milk, IR_{milk}	l/y	250
Meat, IR_{meat}	kg FW/y	100

Table 30. Dose factors for ingestion (D_{ing}^j) (IAEA, 2001), inhalation (D_{inh}^j) (IAEA, 2001) and external exposure (D_{ext}^j) (Titley et al. 2002) used in the dose calculations.

Nuclide	D_{ing}^j Sv/Bq	D_{inh}^j Sv/Bq	D_{ext}^j Sv/a per Bq/m ³
I-131	2,2E-08	7,4E-09	7,1E-10
Tc-99m	2,2E-11	1,2E-11	2,6E-10

Table 31. Correction coefficients applied in the dose calculations (IAEA, 2001).

Correction coefficient	Units	Value
Time period between harvest and consumption of the crops, T_{crops}	day	14
Time period between harvest and consumption of storage feed, T_{StFeed}	day	90
Average time between collection and human consumption of fresh milk, T_{milk}	day	1
Average time between slaughter and human consumption of cow meat, T_{meat}	day	20
Amount of feed consumed by milk producing cows, DMI_{milk}	kg DW/day	16
Amount of feed consumed by meat producing cows, DMI_{meat}	kg DW/day	12

Table 32. Parameter values used in the calculations of the dose to workers (IAEA, 2001).

Correction coefficient	Units	Value
Density of the sewage sludge, ρ	kg/m ³	1000
Conversion factor between dry weight and wet weight, $ConvF$	kg DW/kg WW	0.25
Fraction of the year during which exposure occurs, OF	dimensionless	0.228
Concentration of resuspended particles in air, RF	kg/m ³	1E-7

10.3 Results of the dose calculations

The values of the radionuclide concentrations in discharge water and sewage sludge, estimated with the LUCIA model, are presented in Table 33. As mentioned above, these values were obtained from deterministic simulations for a scenario of continuous releases to the studied sewage plants, at a constant release rate (values in Table 28). The predicted differences between the plants are within one order of magnitude and reflect the differences in the release rates applied. The release rates will vary from year to year and therefore the water and sludge concentrations will also experience variations. By dividing the concentrations given in Table 33 with the corresponding release rates (Table 28), a factor can be obtained that can be used to estimate concentrations for a given annual release rate. It should be noted that the release rates from hospitals are not really constant during the year, but follow a more or less pronounced pulse pattern.

Table 33. Radionuclide concentrations in water discharged from studied sewage plants and in the sewage sludge, predicted with the LUCIA model

Sewage plant	Nuclide	C_{water} , Bq/m ³	C_{sludge} , Bq/ kg DW
Kungsängverket, Sweden	Tc-99m	5,0E+03	2,9E-01
	I-131	6,6E+03	9,4E+01
Viikinmäki, Finland	Tc-99m	4,2E+03	3,7E-01
	I-131	7,0E+03	9,4E+01
VEAS Vestfjorden avløpsselskap, Norway	Tc-99m	5,9E+04	2,4E-01
	I-131	8,1E+03	7,2E+01
Renseanlaeg Vest, Denmark	I-131	7,3E+03	8,8E+01
Skólpa Klettagardar, Iceland	I-131	6,1E+03	1,7E+02

However, as shown in Avila *et al.* (2007), the yearly average concentrations predicted for pulse releases are very close to the values obtained if a constant release rate is used, if the total release during the year is the same and the releases occur continuously during the year.

Doses from ingestion of water and fish were calculated using the activity concentrations in water presented in Table 34. The values obtained, presented in Table 34, are conservative estimates that do not take into account the dilution of the waters discharged from the plant in the final recipient. For Tc-99m the estimated doses, for all studied plants, are well below 10 $\mu\text{Sv/a}$, which is a commonly accepted exemption level (EU). Hence, for Tc-99m the assumed release rates do not lead to substantial doses by the water pathway, independently of the properties of the final receptor for the water discharged from the sewage plants. On the contrary, for I-131 doses above the exemption levels are obtained, if dilution in the final recipient is not taken into account. The effect of dilution in the final recipient has to be evaluated on a case by case basis. This can be done using simple screening models, as those presented in IAEA (2001). For the dose values presented in Table 34, dilution factors between 10 and 100 would be sufficient to obtain doses below 10 $\mu\text{Sv/a}$. As shown in Avila *et al.* (2007), larger dilution factors are commonly observed for Swedish sewage plants and we expect that the same holds for all plants included in this study. Hence, it can be concluded that, for the release rates considered in this study, the doses to potentially exposed individuals by the water pathway are insignificant.

Table 34. Predicted values of the annual dose rates, in Sv/a, from water and fish ingestion or the studied sewage plants.

Sewage plant	Nuclide	<i>Dose_{water}</i> , Sv/a	<i>Dose_{fish}</i> , Sv/a	<i>Dose_{total}</i> , Sv/a
Kungsängverket, Sweden	Tc-99m	6,6E-08	6,6E-08	1,3E-07
	I-131	8,7E-05	1,8E-04	2,6E-04
Viikinmäki, Finland	Tc-99m	5,6E-08	5,6E-08	1,1E-07
	I-131	9,3E-05	1,9E-04	2,8E-04
VEAS Vestfjorden avløpsselskap, Norway	Tc-99m	7,8E-07	7,8E-07	1,6E-06
	I-131	1,1E-04	2,1E-04	3,2E-04
Renseanlaeg Vest, Denmark	I-131	9,7E-05	1,9E-04	2,9E-04
Skólpa Klettagardar, Iceland	I-131	8,0E-05	1,6E-04	2,4E-04

Doses to sewage workers from inhalation and external exposure were calculated using the activity concentrations in sewage sludge presented in Table 35. The values obtained, presented in Table 35, are conservative estimates, as it is assumed that the hypothetical sewage worker is exposed to the contaminated sludge during the whole duration of the working time, i.e. 8 hours every working day. The inhalation doses were insignificant, for both Tc-99m and I-131, in all studied plants. For Tc-99m even the external exposure doses

were well below $10 \mu\text{Sv/a}$ and these can therefore be considered as being insignificant. The doses to sewage workers from I-131 were also below, although close to $10 \mu\text{Sv/a}$. However, if uncertainties in the prediction of activity concentrations in sludge are considered, then the probability of obtaining doses above $10 \mu\text{Sv/a}$ may not be insignificant (see Avila *et al.* 2007). It can therefore be concluded that doses to sewage workers require a more realistic and case by case consideration.

Table 35. Predicted values of annual dose rates, in Sv/a, to sewage workers in the studied sewage plants.

Sewage plant	Nuclide	$Dose_{ext}$ Sv/a	DF_{inh} Sv/a	$Dose_{total}$ Sv/a
Kungsängverket, Sweden	Tc-99m	4,3E-09	1,7E-16	4,3E-09
	I-131	3,8E-06	3,3E-11	3,8E-06
Viikinmäki, Finland	Tc-99m	5,6E-09	2,2E-16	5,6E-09
	I-131	3,8E-06	3,3E-11	3,8E-06
VEAS Vestfjorden avløpsselskap, Norway	Tc-99m	3,6E-09	1,4E-16	3,6E-09
	I-131	2,9E-06	2,6E-11	2,9E-06
Renseanlaeg Vest, Denmark	I-131	4,2E-06	3,6E-11	4,2E-06
Skólpa Klettagardar, Iceland	I-131	7,0E-06	6,0E-11	7,0E-06

Doses to a hypothetical farmer that uses the sewage sludge for fertilization of agricultural lands are presented in Tables 36 and 37. The estimated doses were, for both studied radionuclides and all sewage plants, well below the commonly accepted exemption level of $10 \mu\text{Sv/a}$. The doses were also much lower than the doses to the sewage workers and doses by the water pathway.

Table 36. Predicted values of external and inhalation annual dose rates, in Sv/a, to an hypothetical farmer, that uses the sludge produced in the studied sewage plants for fertilization.

Sewage plant	Nuclide	$Dose_{ext, farmer}$ Sv/a	$DF_{inh, farmer}$ Sv/a	$Dose_{total}$ Sv/a
Kungsängverket, Sweden	Tc-99m	1,3E-13	4,2E-21	1,3E-13
	I-131	3,6E-09	3,2E-14	3,6E-09
Viikinmäki, Finland	Tc-99m	1,7E-13	6,4E-21	1,7E-13
	I-131	3,6E-09	3,2E-14	3,6E-09
VEAS Vestfjorden avløpsselskap, Norway	Tc-99m	1,1E-13	4,2E-21	1,1E-13
	I-131	2,8E-09	2,4E-14	2,8E-09
Renseanlaeg Vest, Denmark	I-131	3,9E-09	3,4E-14	3,9E-09
Skólpa Klettagardar, Iceland	I-131	6,6E-09	5,8E-14	6,6E-09

Table 37. . Predicted values of annual dose rates, in Sv/a, from ingestion of crops, milk and meat to an hypothetical farmer that uses the sludge, produced in the studied sewage plants, for fertilization

Sewage plant	Nuclide	$Dose_{crop}$ Sv/a	$Dose_{milk}$ Sv/a	$Dose_{meat}$ Sv/a
Kungsängverket, Sweden	Tc-99m	6,9E-64	3,0E-48	1,5E-71
	I-131	1,1E-09	1,2E-08	3,5E-09
Viikinmäki, Finland	Tc-99m	9,2E-63	3,9E-48	1,9E-71
	I-131	1,1E-08	1,2E-08	3,5E-09
VEAS Vestfjorden avløpsselskap, Norway	Tc-99m	6,0E-63	2,5E-48	1,3E-71
	I-131	8,8E-09	9,2E-09	2,7E-09
Renseanlaeg Vest, Denmark	I-131	1,1E-08	1,1E-08	3,3E-09
Skólpa Klettagardar, Iceland	I-131	2,0E-09	2,2E-08	6,4E-9

Table 38. Doses total related to the agricultural pathway, Sv/a

Sewage plant	Nuclide	<i>Dose_{total}</i> Sv/a
Kungsängverket, Sweden	Tc-99m	1,3E-13
	I-131	2,0E-08
Viikinmäki, Finland	Tc-99m	1,7E-13
	I-131	3,0E-08
VEAS Vestfjorden avløpsselskap, Norway	Tc-99m	1,1E-13
	I-131	2,3E-08
Renseanlaeg Vest, Denmark	I-131	2,9E-08
Skólpa Klettagardar, Iceland	I-131	6,4E-9

10.4 Conclusions from dose assessments

Doses from radionuclides that routinely released from hospitals into sewage systems have been estimated for selected plants in all Nordic countries. The design of sewage plants is rather similar between Nordic countries and also comparable waste water treatments are carried out at the plants in question.

The results indicate that in case of routine releases the annual doses to the public associated with the final recipient of the discharge from the sewage plants are most likely insignificant. For all radionuclides the estimated values are well below 10 µSv/y even if dilution in the final recipient is ignored. I-131 shows the highest doses and can approach 10 µSv/y if no dilution occurs.

Doses associated with usage of sewage sludge such as farmer using sludge for fertilization are lower than doses associated with the water pathways.

Sewages workers are exposed to the contaminated sludge externally or via inhalation. The inhalation doses were insignificant for both Tc-99m and I-131. The external doses from Tc-99m were low and well below 10 µSv/y. On the other hand external doses from I-131 were closer to 10 µSv/y, if deterministically estimated. But, if uncertainties in the predictions of activity concentrations in sludge are considered, then the probability of obtaining doses above 10 µSv/y may not be insignificant.

In case of accidental releases to sewage plants, it is important to take into account the dynamics in the variation of the activity concentrations in the sewage water and sludge. This would allow more properly estimation of the time variation of the doses and identification of the people that can be affected.

References

- Avila, R., Broed, R. and Pereira, A. (2003). Ecolego - A Toolbox for Radioecological Risk Assessments. International Conference on the Protection of the Environment from the Effects of Ionising Radiation, 6 – 10 October 2003, Stockholm, Sweden.
- Avila, R., Cruz, I., Sundell-Bergman, S. och Hasselblad, S. (2007). Radiological consequences of radionuclide releases to sewage systems from hospitals in Sweden. *SSI Report 2007:10*.
- EFOR, version 2.21 (1993). Computer programme available from EFOR, c/o I. Krüger Systems AS, Gladsaxevej 363, DK-2860 Søborg, Denmark.
- Erlandsson B., Mattsson S., (1978) Medically used radionuclides in sewage sludge. *Water, Air and Soil Pollution* 9, 199-206
- EU (2000) Radiation Protection 122 Practical Use of the Concepts of Clearance and Exemption – *Part 1, Guidance on General Clearance Levels for Practices*.
- Fenner, F. D. and Martin, J.E. (1997). Behavior of Na¹³¹I and meta (¹³¹I) iodobenzylguanidine (MIBG) in municipal sewerage. *Health Phys.* 73, 333-339.
- Finnish national guides and standards:
Guide ST 6.1 Radiation Safety Requirements for Radionuclide Laboratories (1 July 1999). STUK
Guide ST 6.2 Radioactive Wastes and Discharges (1 July 1999). STUK
Guide ST 6.3 Use of Radiation in Nuclear Medicine (18 March 2003). STUK
- Henze, M., Grady, C. P. L. Jr., Gujer, W., Marais, G. v. R. and Matsuo, T. (1987). Activated sludge model No. 1. *Scientific and Technical Report No. 1, IAWPRC, London*.
- IAEA (2001). Generic models for use in assessing the impact of discharges of radioactive substances to environment. *Safety report series No. 19*.
- IAEA, 2004. Sediment Distribution Coefficients and Concentration Factors for Biota in the Marine Environment. *IAEA Technical Reports Series no. 422*. International Atomic Energy Agency, Vienna
- Ingemansson T., Mattsson S., Erlandsson B., (1981) Sewage sludge – a possible indicator for radionuclides released to the atmosphere from nuclear power plants. *Health physics* Vol.41, No. 6, 815-822.
- Karlsson, I and Smith, G. (1991). Pre-precipitation facilitates nitrogen removal without tank expansion. *Water Sciences Technology.* 23, 811-817.
- Korpela, H., 2005. Use of Radiopharmaceuticals in Finland in 2003. *STUK-B-STO 58. Helsinki*. (English abstract)
- Puhakainen M., (1998) Detection of radionuclides in sewage water and sludge. *Radiochemisrty Vol.40, No.6, 529-533*
- Standard SFS-EN ISO 5667-13 (20.4.1998). Water quality. Sampling. Part 13: Guidance on sampling of sludges from sewage and water treatment works.

Statsrådets beslut (282/1994) on användning av slam från reningsverk inom jordbruket.

Titley, J.G., carey, A.d., Crockett, G.M., Ham, G.J., Harvey, M.P., Mobbs, S.F., Tournette, C., Penfold, J:S.S. and Wilkins, B., (2000) Investigation of the Source and Fate of Radioactive Discharges to Public Sewers. *Technical Report P288*. Environment Agency, UK.

Xu, S. and Hultman, B. (1996). Experiences in wastewater characterisation and model calibration for the activated sludge process. *Water Sciences Technology*. 33(12), 89-98.

Appendix A: Detailed Description of the LUCIA Model

A-1. Purpose

This appendix describes the details of the dynamic model LUCIA which was developed to perform realistic estimates of the exposures resulting for all potentially relevant recipients and radionuclides of interest.

Section A-2 describes the mathematical model. Parameter values are discussed in Section A-3. The following Section A-4 describes the results of a sensitivity analysis performed with the aim to identify the most important input parameters.

A-2. The mathematical model

The mathematical model consists of system of ordinary differential equations (ODE) representing the mass balance in different compartments (see Table 8.1 in the main report). Each ODE accounts for radionuclide fluxes in and out from a compartment and losses by radioactive decay. The fluxes between compartments are calculated by multiplying a transfer rate coefficient (TC) by the radionuclide inventory in the compartment:

$$\frac{dA_k^j}{dt} = F_{Out\ to\ k}^j - F_{k\ to\ Out}^j + \sum_i F_{i\ to\ k}^j - \sum_i F_{k\ to\ i}^j - \lambda^j * A_k^j$$

$$F_{i\ to\ k}^j = TC_{i\ to\ k}^j * A_i^j$$

$$F_{k\ to\ i}^j = TC_{k\ to\ i}^j * A_k^j$$

$$F_{k\ to\ Out}^j = TC_{k\ to\ Out}^j * A_k^j$$

(A-1)

where

A_k^j is the inventory of the ***j-th*** radionuclide in compartment ***k*** [Bq]

A_i^j is the inventory of the ***j-th*** radionuclide in compartment ***i*** [Bq]

$F_{Out\ to\ k}^j$ is the flux of the ***j-th*** radionuclide from outside the system (source) into compartment ***k*** [Bq/day],

$F_{k\ to\ Out}^j$ is the flux of the ***j-th*** radionuclide from compartment ***k*** out from the system [Bq/day],

$F_{i\ to\ k}^j$ is the flux of the ***j-th*** radionuclide from compartment ***i*** to compartment ***k*** [Bq/day],

$F_{k\ to\ i}^j$ is the flux of the ***j-th*** radionuclide from compartment ***k*** to compartment ***i*** [Bq/day],

$TC_{i\ to\ k}^j$ is the transfer rate coefficient of the ***j-th*** radionuclide from compartment ***i*** to compartment ***k*** [1/day],

$TC_{k\ to\ i}^j$ is the transfer rate coefficient of the ***j-th*** radionuclide from compartment ***k*** to compartment ***i*** [1/day],

$TC_{k\ to\ Out}^j$ is the transfer rate coefficient of the ***j-th*** radionuclide from compartment ***k*** out from the system [1/day],

λ^j is the decay rate of the ***j-th*** radionuclide [1/day].

The equations for the transfer rate coefficients (TC) are given below. All TCs are expressed with functions of the fluxes of water, suspended solids and sludge between compartments. This approach allows keeping the number of radionuclide specific parameters to a minimum. Most model parameters can be easily obtained from common quantities measured at the sewage works.

Transfer rate coefficients for the transport with water (TC_{R1ToR2} , TC_{R2ToR3} , TC_{R3ToR2} , TC_{R3ToR4} , $TC_{R4ToOut}$)

$$TC_{R1ToR2} = \frac{Q}{V_{R1}} \quad (A-2)$$

$$TC_{R2ToR3} = \frac{(1 + par1) * Q}{V_{R2}} \quad (A-3)$$

$$TC_{R3ToR2} = \frac{par1 * Q}{V_{R3}} \quad (A-4)$$

$$TC_{R3ToR4} = \frac{Q}{V_{R3}} \quad (A-5)$$

$$TC_{R4ToOut} = \frac{Q}{V_{R4}} \quad (A-6)$$

where

Q is the waste water flux into the sewage plant [m^3/day],

V_{R1} , V_{R2} , V_{R3} and V_{R4} are the total volumes of the primary sedimentation basins, the basins for biological treatment, the secondary sedimentation basins and the basin for final polishing respectively [m^3],

$par1$ is the fraction of the waste water flux that is returned as backflow to the basins for biological treatment [r.u].

The above equations assume that the flux of waste water between compartments is the same as the flux of incoming water. Losses of water to the air and to the sludge treatment are considered be negligible.

Transfer rate coefficients for the processes of sedimentation ($TC_{R1ToR1sed}$ and $TC_{R3ToR3sed}$)

$$TC_{R1ToR1sed} = \frac{FluxPr imSludge}{V_{R1}} * \frac{Kd_{R1}}{ConcSS * ESS_{R1} * Kd_{R1} + 1} \quad (A-7)$$

$$FluxPr imSludge = Q * (ConcSS * (1 - ESS_{R1}) + ConcCOD * (1 - ECOD_{R1}) * ConF_{R1}) \quad (A-8)$$

$$TC_{R3ToR3sed} = \frac{FluxSecSludge}{(1 - par2) * V_{R2}} * \frac{Kd_{R2}}{ConcSS_{R2} * Kd_{R2} + 1} * \frac{R2}{R3} \quad (A-9)$$

$$FluxSecSludge = Q * ConcCOD * ECOD_{R1} * ConF_{R2} \quad (A-10)$$

$$ConcSS_{R2} = \frac{ConcCOD * ECOD_{R1} * ConF_{R2}}{(1 + par1) * (1 - par2)} + ConcSS * ESS_{R1} * ESS_{R2} \quad (A-11)$$

where

Q is the waste water flux into the sewage plant [m^3/day],

V_{R1} is the total volume of the primary sedimentation basins [m^3],

V_{R2} is the total volume of the basins for biological treatment [m^3],

$ConcSS$ is the concentration of suspended solids (SS) in the incoming waste water [$\text{kg dw}/\text{m}^3$],

$ConcSS_{R2}$ is the concentration of suspended solids (SS) in R2 [$\text{kg dw}/\text{m}^3$],

$ConcCOD$ is the concentration of chemical oxygen demand (COD) in the incoming wastewater [kgCOD/m^3],

$ConF_{R1}$ is a conversion factor between COD and SS units for R1 [kgSS/kgCOD],

$ConF_{R2}$ is a conversion factor between COD and SS units for R2 [kgSS/kgCOD],

ESS_{R1} is the efficiency for reduction of the concentration of SS in R1 [r.u.],

ESS_{R2} is the efficiency for reduction of the concentration of SS in R2 [r.u.],

$ECOD_{R1}$ is the efficiency for reduction of the concentration of COD in R1 [r.u.]

Kd_{R1} is the distribution coefficient of the radionuclide in R1 [m^3/kg],

Kd_{R2} is the distribution coefficient of the radionuclide in R2 [m^3/kg],

$par1$ is the fraction of the waste water flux that is returned from R3 to the basins for biological treatment [r.u.],

$par2$ is the fraction of the secondary sludge that is returned from R3sed to the basins for biological treatment [r.u.].

$FluxPrimSludge$ is the flux of primary sludge to the sludge treatment [kg/day],

$FluxSecSludge$ is the flux of secondary sludge to the sludge treatment [kg/day],

$R2$ is the radionuclide inventory in R2 [Bq],

$R3$ is the radionuclide inventory in R3 [Bq].

Equations (A-7) and (A-9) describe the rate of removal of radionuclides absorbed to suspended solids by sedimentation. The sorption of radionuclides to suspended solids in R1 and R2 is assumed to occur instantaneously. The resulting partition between water and suspended solids depends of the distribution coefficients (Kd), which values depend on the concentration of suspended solids and the chemical conditions. Different Kd values are used in equations 7 and 9 because different conditions prevail in R1 and R2.

The sedimentation of suspended solids is estimated from the production of primary and secondary sludge. If values of the fluxes of primary and secondary sludge are not available, then these can be estimated using equations (A-8) and (A-10). These equations express the production of sludge as a function of the concentration of suspended solids and COD in the incoming waste water and the efficiency for their removal from the water during the treatment. The efficiencies are defined as follows:

- ESS_{R1} is the ratio between the concentration of suspended solids in the water that is pumped from R1 to R2 and the water incoming to the plant.
- ESS_{R2} is the ratio between the concentration of suspended solids in the water that is pumped from R3 to R4 and the water that is pumped from R1 to R2.
- $ECOD_{R1}$ is the ratio between the concentration of COD in the water that is pumped from R1 to R2 and the water incoming to the plant.

Equations (A-7) and (A-9) also take into account the sludge production from dissolved and small particles of organic matter (COD) that takes place in R1 and R2. Part of the sludge removed in the secondary sedimentation is pumped back to the basins for biological treatment to maintain a constant stock of bacteria. To account for this, a correction was introduced in equation (A-9) with the help of an additional - $par2$. The value of this parameter affects the concentration of suspended solids in R2 and the time spent by a particle in the biological treatment. The concentration of suspended solids in R2 is

normally kept at a more or less constant value and is usually known. If values are not available, then these can be estimated with equation (A-11).

Transfer rate coefficients for the transport with sludge to the biological and sludge treatments ($TC_{R1sedToT1}$, $TC_{R3sedToR2}$ and $TC_{R3sedToT1}$)

$$TC_{R1sedToT1} = \frac{1}{RT_{R1sed}} \quad (A-12)$$

$$TC_{R3sedToT1} = \frac{1 - par2}{RT_{R3sed}} \quad (A-13)$$

$$TC_{R3sedToR2} = \frac{par2}{RT_{R3sed}} \quad (A-14)$$

where

$par2$ is the fraction of the secondary sludge that is returned from R3sed to the basins for biological treatment [r.u.],

RT_{R1sed} is the residence time of the sludge in R1sed [days],

RT_{R3sed} is the residence time of the sludge in R3sed [days].

Transfer rate coefficients for the radionuclide transport between different stages of the sludge treatment (TC_{T1ToT2} , TC_{T2ToT3} and $TC_{T3ToOut}$)

$$TC_{T1ToT2} = \frac{1}{RT_{T1}} \quad (A-15)$$

$$TC_{T2ToT3} = \frac{1 - FracToAir}{RT_{T2}} \quad (A-16)$$

$$TC_{T3ToOut} = \frac{1}{RT_{T3}} \quad (A-17)$$

where

RT_{T1} is the residence time of the sludge in T1 [days],

RT_{T2} is the residence time of the sludge in T2 [days],

RT_{T3} is the residence time of the sludge in T3 [days],

$FracToAir$ is the fraction of sludge that is released to air in T2 [r.u]

A fraction of the sludge is released to air ($FracToAir$) which results in reduction of the sludge flux to T3 and increase of the radionuclide concentrations. It is conservatively assumed that the radionuclides are not released to air.

Calculation of radionuclide concentrations in water and sludge

The concentration of radionuclides in water and sludge released from sewage works can be estimated by dividing the radionuclide fluxes calculated with the model by the fluxes of outgoing water and sludge respectively:

$$C_{WaterOut}^j = \frac{Flux_{R4ToOut}^j}{Q} \quad (A-18)$$

$$C_{SludgeOut}^j = \frac{Flux_{T3ToOut}^j}{(1 - FracToAir) * (FluxPrimSludge + FluxSecSludge)} \quad (A-19)$$

where

$C_{WaterOut}^j$ is the j -th radionuclide concentration in the water discharged from the plant [Bq/m³],
 $C_{SludgeOut}^j$ is the j -th radionuclide concentration in the sludge released from the plant [Bq/kg dw],
 Q is the waste water flux into the sewage plant [m³/day],
 $FluxPrimSludge$ is the flux of primary sludge to the sludge treatment [kg/day],
 $FluxSecSludge$ is the flux of secondary sludge to the sludge treatment [kg/day],
 $Flux_{R4ToOut}^j$ is the j -th radionuclide flux from R4 out from the plant [Bq/day],
 $Flux_{T3ToOut}^j$ is the j -th radionuclide flux from T3 out from the plant [Bq/day].

The radionuclide concentrations in sludge and water in intermediate stages of the treatment process can be calculated in a similar way, by dividing the appropriated radionuclide fluxes by the water or sludge fluxes. For example, the radionuclide concentration in the primary sludge can be estimated by dividing the radionuclide flux from R1 to T1 by the flux of primary sludge, i.e. the primary sludge production.

B-3. Model parameters

Most of the parameters required by the model are features of the sewage system that are either known (as the volume of the basins) or are commonly measured (as the water and sludge fluxes). In Table A-1 deterministic values and in some cases probability distributions are provided for these model parameters, which were derived from data measured in *Kungsängsverket* sewage plant in Uppsala, during 2003-2004. Deterministic values are also given for the *Viikinmäki* plant in Helsinki, which were obtained from the answers to the questionnaires.

The only radionuclide specific parameters required by the model are the distribution coefficients KdR1 and KdR2. Although an extensive literature review was carried out, distribution coefficients for sludge were not found for any of the elements of interest: Iodine, Technetium, Indium and Thallium. In the case of Iodine and Technetium Kd values have been reported for organic soils, which to some extent can be considered as representative for sewage sludge, consisting mainly of organic material. In the case of Indium and Thallium and their analogues from the same group of the periodic system (Boron, Aluminium and Gallium), values for organic soil have not been reported. For the sensitivity studies presented below the Kd values presented in Table A-2 were used. For Iodine and Technetium the values were taken from Avila (2006), where a review of values for organic soils is included. For Indium and Thallium three set of values were used corresponding to values reported for Cadmium, Tin and Lead in organic soils (SKB 2002). These elements were judged to have the closest chemical properties to Indium and Thallium, among those elements for which Kd values for organic soils were found in the literature.

Table A-1 Radionuclide independent parameters used in the LUCIA model for the *Kungsängsverket* sewage plant, Uppsala (estimated from measured data at the sewage plant during 2003-2004) and for the *Viikinmäki* plant in Helsinki (in bold)

Parameter	Units	Best estimate	Min	Max	Distribution
Conversion factor between COD and SS units for R1, <i>ConFR1</i>	kg DW/kgCOD	0.58	0.29	0.87	Triangular (0.29, 0.58, 0.87)
Conversion factor between COD and SS units for R2, <i>ConFR2</i>	kg DW/kgCOD	0.33	0.165	0.495	Triangular (0.165, 0.33, 0.495)
Concentration of chemical oxygen demand (COD) in the incoming water, <i>ConcCOD</i>	kgCOD/m ³	0.51 0.52	0.27	0.71	Normal (0.51, 0.13)
Concentration of suspended solids (SS) in the incoming waste water, <i>ConcSS</i>	kg DW/m ³	0.22 0.31	0.11	0.34	Normal (0.22, 0.07)
Efficiency for reduction of the concentration of COD in R1, <i>ECODR1</i>	r.u	0.47	0.36	0.58	Triangular (0.36, 0.47, 0.58)
Efficiency for reduction of the concentration of SS in R1, <i>EssR1</i>	r.u	0.36 0.5	0.17	0.54	Triangular (0.17, 0.38, 0.54)
Efficiency for reduction of the concentration of SS in R2, <i>EssR2</i>	r.u	0.075 0.026	0.048	0.11	Triangular (0.048, 0.075, 0.11)
Fraction of sludge that is released to air in T2, <i>FractToAirT2</i>	r.u	0.4	0.32	0.48	Triangular (0.32, 0.4, 0.48)
Waste water flux in the sewage plant, <i>Q_{water}</i>	m ³ /day	46066 210000	36506	64435	Lognormal (47701, 8812)
Residence time of the sludge in R1sed, <i>ResTimeR1sed</i>	days	0.8	0.6	1	Uniform (0.8, 1)

Parameter	Units	Best estimate	Min	Max	Distribution
Residence time of the sludge in R3sed, $ResTimeR3sed$	days	0.8	0.6	1	Uniform (0.6, 1)
Residence time of the sludge in T1, $ResTimeT1$	days	0.8	0.6	1	Triangular (0.6, 0.8, 1)
Residence time of the sludge in T2, $ResTimeT2$	days	17	13.6	20.4	Triangular (13.6, 17, 20.4)
Residence time of the sludge in T3, $ResTimeT3$	days	4	3.2	4.8	Triangular (3.2, 4, 4.8)
Total volume of the primary sedimentation basins, $VR1$	m ³	8520 45790			
Total volume of the basins for biological treatment, $VR2$	m ³	31300 92000			
Total volume of the secondary sedimentation basins, $VR3$	m ³	27130 105120			
Total volume of the basin for final polishing, $VR4$	m ³	11950 4320			
Fraction of the waste water flux that is returned from R3 to the basins for biological treatment, $par1$	r.u	0.6	0.3	0.9	Triangular (0.3, 0.6, 0.9)
Fraction of the secondary sludge that is returned from R3sed to the basins for biological treatment, $par2$	r.u	0.45	0.225	0.675	Triangular (0.225, 0.45, 0.675)

Table A-2. Distribution coefficients Kd used in the LUCIA model (m^3/kg)

Element	Best estimate	Min	Max	Distribution	Reference
I	0.03	0.0008	0.3	Lognormal (0.08, 0.19)	Avila (2006)
Tc	0.003	0.00045	0.07	Logtriangular (0.00045, 0.003, 0.07)	Avila (2006)
In, TI	0.8	0.008	80	Logtriangular (0.008, 0.8, 80)	Values for Cd in organic soils - SKB (2002)
	20	8	60	Logtriangular (8, 20, 60)	Values for Pb in inorganic soils -SKB (2002)
	2	0.2	20	Logtriangular (0.2, 2, 20)	Values for Sn in inorganic soils -SKB (2002)

A-4. Sensitivity analysis

The LUCIA model was implemented in the software package Ecolego (Avila *et al.* 2000), where the numerical solver ode15s was used for solving the system of differential equations. The sensitivity of the model to variation in the model parameters was studied using the software package Eikos (Ekström and Broed, 2006). The sensitivity study was carried out for I-131, which is one of the significant radionuclides for the exposure of workers at a WWTP.

A probabilistic simulation was carried out using Latin-Hypercube sampling for the case of a constant input rate of the radionuclide into the sewage plant. The parameters were assigned the distributions shown in Tables A-1 and A-2. The studied endpoints were the concentration of I-131 in the digested sludge (T2 in Figure 8.2 of the main document) and the efficiency (Eff) of the wastewater treatment, defined as the activity concentration in the water coming into the plant divided by the activity concentration in the water released from the plant. The concentration in digested sludge was selected as endpoint because, according to the information provided by the sewage plants, the workers can be exposed to the sludge mainly during and after the digestion process.

The results of the sensitivity analysis are presented in Fig. A-1 showing values of the Spearman Rank Correlation Coefficients obtained for the two studied endpoints. The Spearman Rank Correlation Coefficient is a good measure of sensitivity for this model, since the dependencies between inputs and outputs is monotonic. The predictions of the concentration in the digested sludge are highly sensitive to the distribution coefficient for the primary sedimentation ($KdR1$), slightly sensitive to the distribution coefficient for the biological treatment ($KdR2$) and practically insensitive to all other model parameters, when considered individually. The same is valid for the efficiency of the wastewater treatment, but this endpoint was also highly sensitive to the water flux, since this parameter determines the residence time of the I-131 in the wastewater treatment.

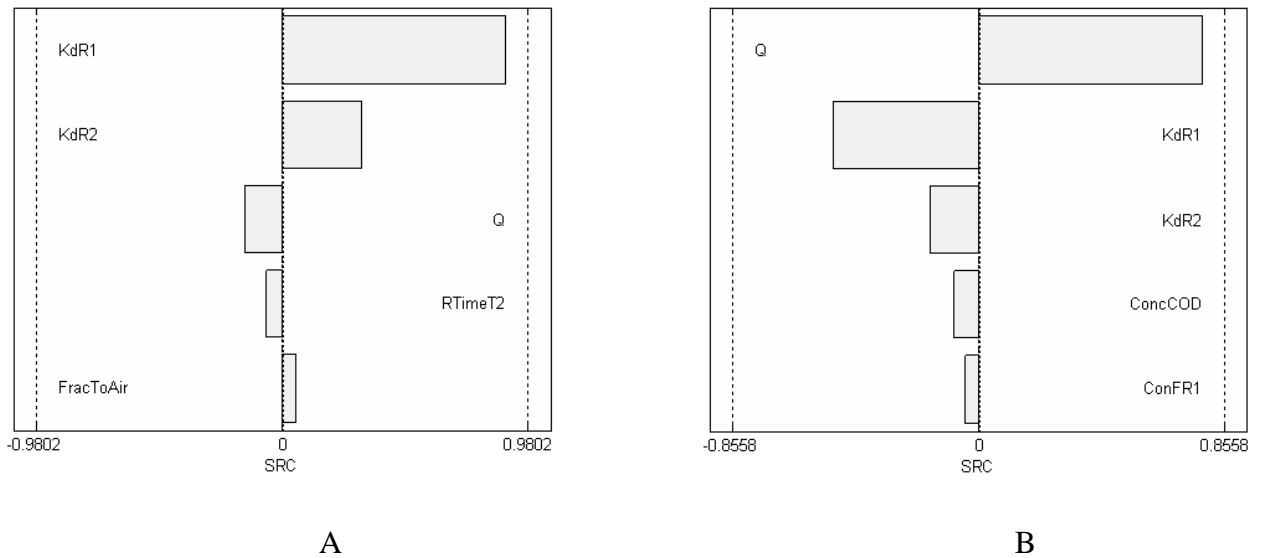

Figure A-1. Tornado graphic showing the Spearman Rank Correlation Coefficients (SRC) obtained for the studied endpoints: Concentration in the digested sludge (A) and Efficiency of the wastewater treatment (B).

The type of dependency between inputs and outputs predicted by the model LUCIA is illustrated in figures A-2 and A-3. The dependencies are monotonic and close to linear. The concentrations in the digested sludge experience a larger variation (up-to a factor of about 8) than the efficiencies of the waste treatment (maximum of about 20 %) for the same variation of the model parameters. From these figures it appears that for the case of chronic releases a simplified regression model could be set-up satisfactorily for these two endpoints.

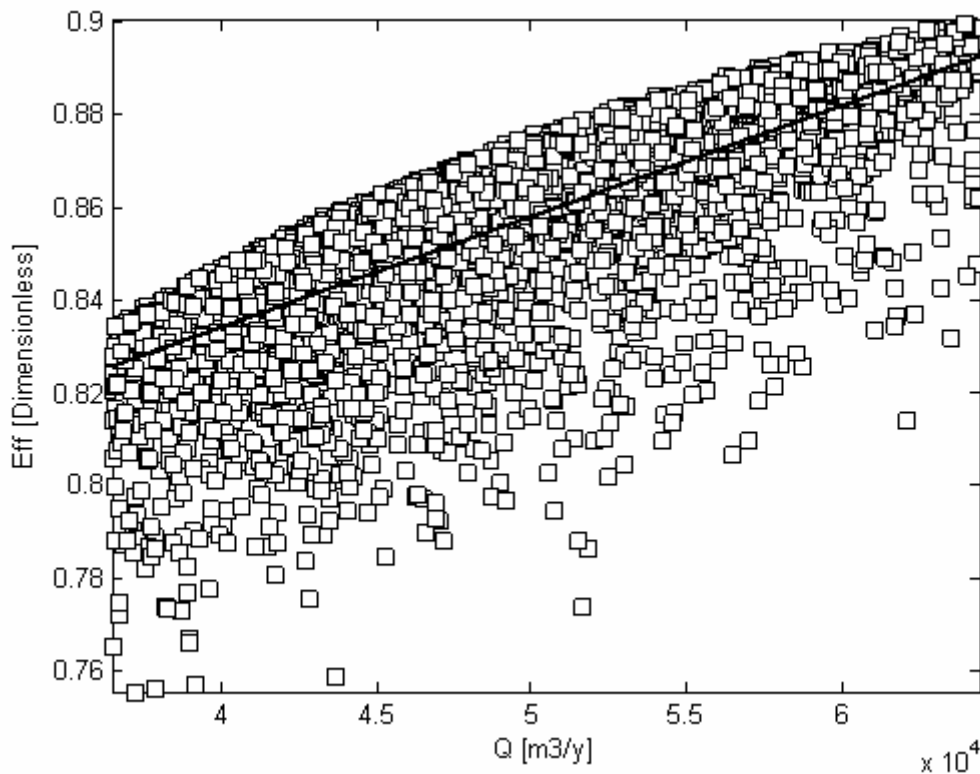

Figure A-2. Scatter plot of efficiency of the wastewater treatment (Eff) against the water flux into the plant (Q) obtained from probabilistic simulations with the LUCIA model

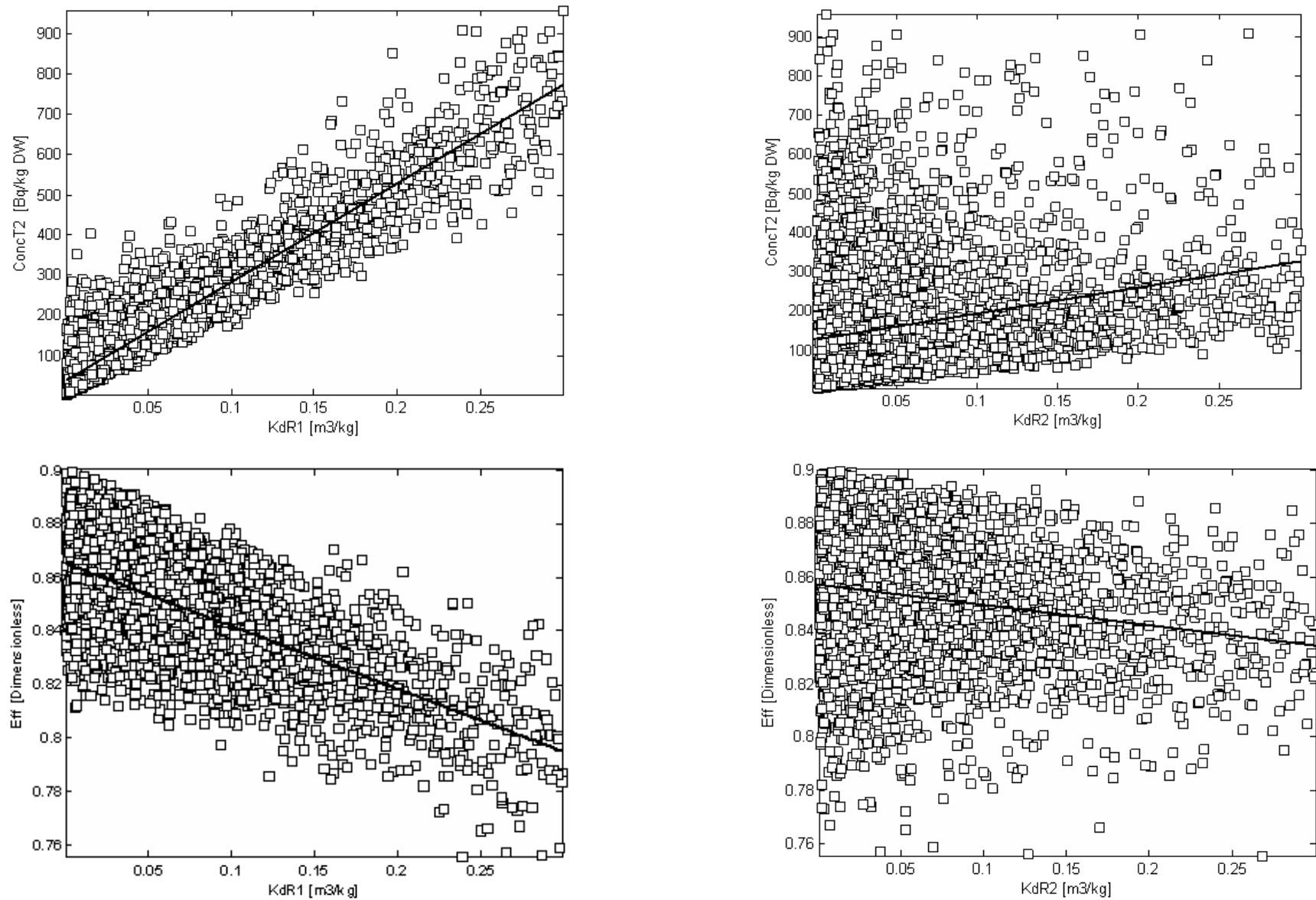

Figure A-3. Scatter plots of the concentrations in digested sludge (ConcT2) and efficiency of the wastewater treatment (Eff) against the distribution coefficients used for the primary sedimentation (KdR1) and biological (KdR2) processes obtained from probabilistic simulations with the LUCIA model

The contribution of the model parameters to the variance of the predictions was estimated using Total Sensitivity Indexes calculated with the Extended Fourier Amplitude Sensitivity Test, EFAST (Ekström and Broed, 2006). This method takes into account interactions between parameters.

The results (Fig. A-4) indicate that 46 % of the variance in the predictions of the ConcT2 is explained by the variance of the KdR1 and the rest by other parameters, but no single parameter contributes with more than 6 %. The sensitivity of this output to other individual parameters, excluding the KdR1, is low. Hence, it seems that the 54 % contribution to the variance of these parameters is associated with higher order interactions. The same observation is valid for the Eff ; the 36 % contribution to the variance from parameters others than KdR1 and Q is probably associated with interactions between parameters.

The values of the First Order Sensitivity Indexes, which do not account for interactions between the parameters, are shown in Fig. A-5. From comparison of Figures A-4 and A-5 it can be concluded that the sensitive parameters (KdR1 and Q) have a much higher individual contribution to the variance when interactions are not taken into account. This result indicates that it is important to use sensible initial values even for relatively insensitive parameters. The estimation sensible initial values for the parameters of the LUCIA model is relatively easy since these correspond to commonly available characteristics of the sewage system.

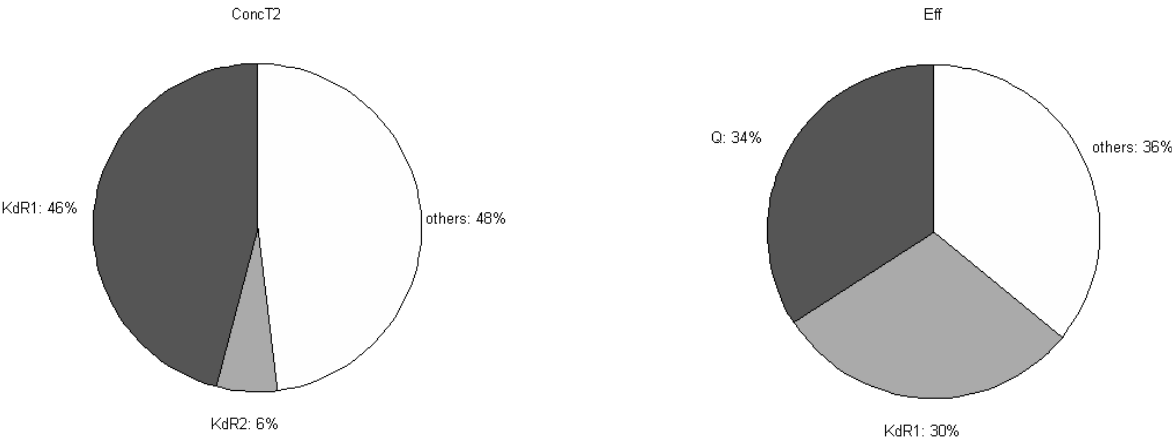

Figure A-4. Contribution of model parameters to the variance in the predictions of the concentration in the digested sludge (ConcT2) and the efficiency of the wastewater treatment (Eff) estimated from the Total Sensitivity Indexes in the Extended Fourier Amplitude Sensitivity Test (EFAST)

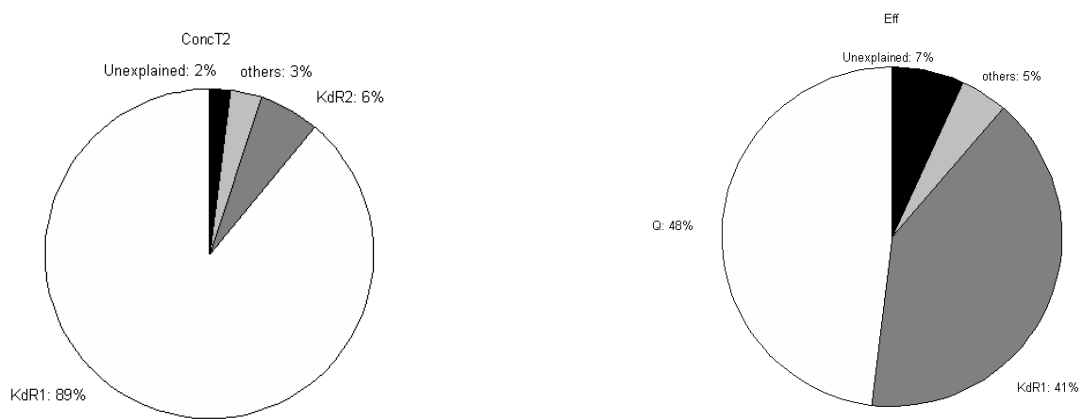

Figure A-5. Contribution of model parameters to the variance in the predictions of the concentration in the digested sludge (ConcT2) and the efficiency of the wastewater treatment (Eff) estimated from the First Order Sensitivity Indexes in the Extended Fourier Amplitude Sensitivity Test (EFAST)

Title	Assessing the impact of releases of radionuclides into sewage systems in urban environment - simulation, modelling and experimental studies – LUCIA
Author(s)	Synnöve Sundell-Bergman ¹⁾ , Rodolfo Avila ²⁾ , Idalmis de la Cruz ²⁾ , Shulan Xu ³⁾ , Marketta Puhakainen ⁴⁾ , Tarja Heikkinen ⁴⁾ , Tua Rahola ⁴⁾ , Ali Hosseini ⁵⁾ , Sven Nielsen ⁶⁾ and Magnus Sigurgeirsson ⁷⁾
Affiliation(s)	¹⁾ Vattenfall Power Consultant, Sweden ²⁾ Facilia AB, Sweden ³⁾ Swedish Radiation Safety Authority, Sweden ⁴⁾ STUK, Finland ⁵⁾ Norwegian Radiation Protection Authority, Norway ⁶⁾ Risø National Laboratory for Sustainable Energy, DTU, Denmark ⁷⁾ Geislavarnir ríkisins, Iceland
ISBN	978-87-7893-259-4
Date	June 2009
Project	NKS-B / LUCIA
No. of pages	78
No. of tables	40
No. of illustrations	38
No. of references	21
Abstract	<p>This report summarises the findings of a project on assessing the impact of releases of radionuclides into sewage systems and was established to provide more knowledge and suitable tools for emergency preparedness purposes in urban areas. It was known that the design of sewage plants, and their wastewater treatments, is rather similar between the Nordic countries. One sewage plant in each of the five Nordic countries was selected for assessing the impact of radionuclide releases from hospitals into their sewerage systems. Measurements and model predictions of dose assessments to different potentially exposed members of the public were carried out. The results from the dose assessments indicate that in case of routine releases annual doses to the three hypothetical groups of individuals are most likely insignificant. Estimated doses for workers are below 10 $\mu\text{Sv/y}$, for the two studied radionuclides $^{99\text{m}}\text{Tc}$ and ^{131}I. If uncertainties in the predictions of activity concentrations in sludge are considered, then the probability of obtaining doses above 10 $\mu\text{Sv/y}$ may not be insignificant. The models and approaches developed can also be applied in case of accidental releases.</p> <p>A laboratory inter-comparison exercise was also organised to compare analytical results across the laboratories participating in the project, using both ^{131}I, dominating man-made radionuclide in sewage systems due to the medical use.</p> <p>A process oriented model of the biological treatment is also proposed in the report that does not require as much input data as for the LUCIA model. This model is a combination of a simplified well known Activated Sludge Model No.1 (Henze, 1987) and the K_d concept used in the LUCIA model. The simplified model is able to estimate the concentrations and the retention time of the sludge in different parts of the treatment plant, which in turn, can be used as a tool for the dose assessment purpose. filled by the activity.</p>
Key words	risk assessment, sewage sludge, radioactive iodine, Tc-99m, dose modelling