

Waste prevention, waste policy and innovation

Jørgensen, Ulrik; Olsen, Stig Irving; Jørgensen, Michael Søgaard; Lauridsen, Erik Hagelskjær; Hauschild, Michael Zwicky; Hoffmann, Leif; Dengsøe, Niels; Nemeskeri, Robert L.; Bodo, Peter; Herczeg, Marton; Szlezak, Jozsef; Vrgoc, Marko; Villanueva, Alejandro; Knudsen, Hans Henrik

Publication date:
2006

Document Version
Publisher's PDF, also known as Version of record

[Link back to DTU Orbit](#)

Citation (APA):
Jørgensen, U., Olsen, S. I., Jørgensen, M. S., Lauridsen, E. H., Hauschild, M. Z., Hoffmann, L., ... Knudsen, H. H. (Ed.) (2006). Waste prevention, waste policy and innovation. Electronic: IPL.

DTU Library

Technical Information Center of Denmark

General rights

Copyright and moral rights for the publications made accessible in the public portal are retained by the authors and/or other copyright owners and it is a condition of accessing publications that users recognise and abide by the legal requirements associated with these rights.

- Users may download and print one copy of any publication from the public portal for the purpose of private study or research.
- You may not further distribute the material or use it for any profit-making activity or commercial gain
- You may freely distribute the URL identifying the publication in the public portal

If you believe that this document breaches copyright please contact us providing details, and we will remove access to the work immediately and investigate your claim.



Report, October 2006

By

Department of Manufacturing
Engineering and Management,
Technical University of Denmark

National Environmental
Research Institute, Denmark

Danish Topic Centre on Waste

The Regional Environmental Center
for Central and Eastern Europe

The project was initiated and supported by
European Science and Technology Observatory

Published by
Department of Manufacturing Engineering and Management, Technical University of Denmark
Building 424, DK-2800 Kgs. Lyngby, Denmark
Front-page photo by Arne Wangel and Stig Irving Olsen, Department of Manufacturing
Engineering and Management

ISBN 978-87-91035-82-7

June 2007

Disclaimer:

The publisher makes no representation, express or implied with regard to the accuracy of the information contained in this report and cannot accept any legal responsibility or liability for any errors or omissions that may be made.

The project was funded by IPTS, ESTO, but neither the European Commission nor any person acting on behalf of the Commission is responsible for the use which might be made of the information contained in the report.

Waste prevention, waste policy and innovation

ESTO-WASTE

Prepared by

Authors:

Ulrik Jørgensen, Stig Irving Olsen, Michael Søggaard Jørgensen, Michael Hauschild, Erik Hagelskjær Lauridsen,
(Department of Manufacturing Engineering and Management (IPL), Technical University of Denmark (DTU))

Robert L. Nemeskeri, Peter Bodo, Marton Herczeg, Jozsef Szlezak
(The Regional Environmental Center for Central and Eastern Europe (REC))

Marko Vrgoc, Alejandro Villanueva
(The Danish Topic Centre on Waste, DTCW)

Leif Hoffmann, Niels Dengsøe
(National Environmental Research Institute (NERI))

Project manager at IPTS:

Zheng Luo

Operating agent:

Hans Henrik Knudsen
(Department of Manufacturing Engineering and Management (IPL), Technical University of Denmark (DTU))

October 2006

CONTENTS

PREFACE AND ACKNOWLEDGEMENTS	9
EXECUTIVE SUMMARY	11
1 INTRODUCTION	15
1.1 Objectives.....	15
1.2 Background.....	15
1.2.1 Introduction to waste prevention.....	15
1.2.2 Waste policy and innovation.....	18
1.3 Project outline.....	18
1.3.1 Case selection.....	20
1.3.2 Expert workshop.....	20
1.3.3 Definitions used in the study.....	21
1.3.4 Data quality and the interpretation of LCA results.....	21
1.3.5 Report structure.....	22
1.4 References.....	22
2 METHODOLOGICAL FRAMEWORK AND PROJECT APPROACH	23
2.1 Environmental impact indicators.....	24
2.1.1 Indicator types.....	25
2.1.2 Environmental indicators for waste prevention.....	25
2.2 Policy analysis framework – patterns, regimes.....	40
2.2.1 Problems of policy analysis – impacts and effectiveness.....	40
2.2.2 Theoretical considerations.....	41
2.2.3 Policy options, instruments and types of innovation.....	49
2.3 References.....	51
3 WASTE FLOWS IN THE EU	55
3.1 General Outlook on Waste Flows.....	56
3.1.1 Municipal Solid Waste.....	56
3.1.2 Industrial (production) waste.....	61
3.1.3 Specific Waste Flows.....	62
3.1.4 Summary on waste flows.....	64
3.1.5 Future waste trends and scenarios.....	65
3.2 Waste flows selected for further analysis.....	67
3.2.1 Selection of waste flows.....	67
3.2.2 Construction and demolition waste.....	68
3.2.3 Textile waste.....	70
3.2.4 WEEE and EoLV.....	70
3.2.5 PVC waste.....	72
3.2.6 Packaging waste.....	74
3.3 References.....	75
4 ENVIRONMENTAL IMPACTS OF WASTE STREAMS – IDENTIFICATION OF PREVENTION POTENTIAL	79
4.1 Waste impact assessment methodology.....	80
4.1.1 System boundaries.....	81
4.2 Construction of the LCA-based material and energy resource indicators.....	81
4.2.1 Quantification of pressures and definition of scenarios.....	83
4.2.2 Data.....	85
4.2.3 From data to results.....	86
4.2.4 Assumptions and delimitations.....	87
4.2.5 System description.....	90
4.3 Results at material level.....	96
4.3.1 Energy and resource indicators.....	96
4.3.2 Hazardousness indicator.....	99
4.4 Aggregation impact of waste streams.....	104
4.5 Environmental life cycle midpoint indicators.....	105
4.5.1 Environmental life cycle midpoint indicators.....	107
4.6 Results at waste stream level.....	115
4.6.1 Environmental impacts of selected case studies.....	120
4.6.2 Conclusion and recommendations.....	122
4.7 References.....	123

5	EXISTING WASTE POLICIES AND ACTIONS.....	127
5.1	Definition and selection of waste prevention actions.....	127
5.1.1	Generic strategies and measures	128
5.1.2	Description of waste prevention cases	130
5.2	Waste prevention actions	131
5.3	Exemplary cases.....	133
5.4	Relations to waste prevention actions	139
5.4.1	Relations between waste prevention actions and materials/ waste fractions and policy measures/ instruments	140
5.4.2	Relations between waste prevention actions and innovation	142
5.5	Conclusions.....	143
5.6	References.....	145
6	CASE STUDIES OF THE IMPACTS OF WASTE MINIMISATION POLICIES ON INNOVATION.....	147
6.1	Selection of cases for detailed study	147
6.1.1	Criteria and candidates for case studies	147
6.1.2	Cases selected	148
6.2	Electronic waste, producer responsibility and hazardous substances.....	149
6.2.1	Materials and their transformation into electronic products.....	150
6.2.2	Environmental impacts and their constitution.....	151
6.2.3	LCA studies covering electrical and electronic equipment.....	152
6.2.4	Policies influencing innovation, environment and waste	155
6.2.5	Policy impacts – patterns and regimes at play	160
6.2.6	Effectiveness of policies and future demands	162
6.3	PVC regulations based on recycling and substitution	163
6.3.1	Material flows in production, use and discarding of PVC products.....	164
6.3.2	Environmental objects, their constitution and impacts.....	166
6.3.3	LCA assessments on PVC.....	167
6.3.4	Policies influencing innovation, environment and waste	169
6.3.5	Policy impacts - patterns and regimes at play	171
6.3.6	Effectiveness of policies and future demands	172
6.4	Textiles – design and use of textiles.....	173
6.4.1	Material flows and waste generation related to textiles	174
6.4.2	Environmental objects and their constitution	176
6.4.3	LCA studies on textiles.....	177
6.4.4	Policies influencing waste and innovation	179
6.4.5	Policy impacts - patterns and regimes.....	185
6.4.6	Effectiveness of policies and future challenges	187
6.5	Building and construction materials, waste prevention and minimisation	188
6.5.1	Material flows of building and construction materials.....	188
6.5.2	Environmental impacts and their constitution.....	191
6.5.3	LCAs on building materials	191
6.5.4	Policies influencing innovation, environment and waste	192
6.5.5	Policy impacts - patterns and regimes at play	195
6.5.6	Effectiveness of policies and future demands	196
6.6	Packaging and packaging waste, waste prevention and minimisation	197
6.6.1	Material flows in the production, use and treatment of packaging materials.....	198
6.6.2	LCAs on packaging materials	198
6.6.3	Policies influencing innovation, environment and waste	201
6.6.4	Policy impacts - patterns and regimes at play	206
6.6.5	Effectiveness of policies and future demands	206
6.7	Policy impacts on environment and innovation	207
6.7.1	Policy impacts concerning electronics	207
6.7.2	Policy impacts concerning PVC.....	209
6.7.3	Policy impacts concerning textiles.....	210
6.7.4	Policy impacts concerning building waste	212
6.7.5	Policy impacts concerning packaging waste.....	214
6.7.6	General lessons on policy impacts	214
6.8	References.....	216
7	CONCLUSIONS AND RECOMMENDATIONS.....	223
7.1	Waste streams in EU25	223
7.2	Prioritization of waste streams from their environmental impact	224

7.2.1	Conclusions at <i>waste material</i> level.....	224
7.2.2	Conclusions at <i>waste stream</i> level	225
7.3	Waste policies and innovation.....	227
7.3.1	Effectiveness of policies	227
7.3.2	Waste prevention and innovation.....	229
7.3.3	Waste prevention and environmental impacts.....	230
7.4	Methodological conclusions.....	231
7.4.1	Policy analyses.....	231
7.4.2	Assessments of environmental impacts.....	232

PREFACE AND ACKNOWLEDGEMENTS

The client of this study was Directorate General JRC/IPTS of the European Commission. The project was initiated in connection with development of waste management strategies for the European Commission. The project was funded by The European Science and Technology Observatory, ESTO.

Partners

The partners in the ESTO WASTE project are the *Department of Manufacturing Engineering and Management (IPL)* at the Technical University of Denmark (DTU), the *National Environmental Research Institute (NERI)*, Denmark, the Danish Topic Centre on Waste (DTCW), and *The Regional Environmental Center for Central and Eastern Europe (REC)*.

IPL has been working with life cycle assessment and environmental policy analysis for the European Commission and Danish Government in the last decades and has hereby contributed to the focus on cleaner technology and integrated product policy as a means of waste prevention. NERI has been involved in policy analysis and advice on waste policies and the use of economic incentives in studies as the Danish governments' environmental sector research facility and also for the EC.

DTCW and REC are partners in The European Topic Centre on Resource and Waste Management (ETC/RWM), designated by the European Environment Agency (EEA); which is a consortium of seven specialist organisations consisting of environmental authorities and research communities in Europe, including, besides the above two, Umweltbundesamt of Austria, the Wuppertal Institute of Germany, the Estonian Environment Information Centre, Agenzia Nazionale per la Protezione dell'Ambiente e per i servizi tecnici (APAT) of Italy, and the Environment Agency for England and Wales. ETC/RWM executes 20+ waste and resource management and policy relevant projects annually, being a recognized centre of excellence in these fields.

EXECUTIVE SUMMARY

The study has two separate, but related, objectives: firstly, to identify waste types and fractions that have high potential to reduce adverse environmental impacts due to resource consumption and hazardousness; secondly, to evaluate waste prevention policies and their interaction with innovation.

The first part of the study provides guidance to policy- and decision-makers, by identifying waste prevention actions with a high potential to reduce the environmental impacts of resource use. This is done based on the contemporary available waste statistics in the EU, followed by a life cycle based approach to identify those waste types and fractions where waste prevention have high potential to reduce environmental impacts and evaluates existing prevention policy cases. The whole value chain is of interest and both quantity and quality of waste streams has been taken into account.

The second part of the study has analysed how the dynamics of innovation can be influenced by various approaches from waste policies and hence, how waste prevention policies could potentially change the environmental impacts from waste. This includes an analysis of how different waste policies and implementation tools influence the dynamics of both technical, social, and market innovations, how waste policies impact different part of the supply chain involved, and which policies patterns and implementations have shown to be efficient.

Methodological framework

The project combines two analytical traditions: the technical life cycle assessment approach where the impacts of waste streams are analysed with waste stream mapping as input, **and** the classification and evaluation of policies relevant to waste prevention and innovation processes with the mapping of patterns of waste related policies and actions, their interaction with innovation processes and their actual environmental effectiveness as focus.

In the technical assessment of environmental impacts of waste streams a life cycle perspective is adapted. Since waste flows are composed of many fractions each holding specific environmental impact potentials, the waste flows must be broken down into materials and the analysis performed on these. A simplified indicator method is developed for the purpose of an environmental ranking of different waste materials and waste streams.

Three simplified, life-cycle based, environmental indicators are defined, described and used: An energy indicator, a resource indicator and a hazardousness indicator – in this study the latter is constructed as a qualitative scoring method. These indicators cover the main impacts related to a material in a life cycle perspective: the energy use, the loss of scarce resources, and the use and emissions of hazardous substances. The indicators do *not* cover the use stage of products made from these materials.

An analytical framework focusing on the constitution of ‘regulatory regimes’ is developed with focus on the role of the institutional framework and the translations resulting from moving from the policy discourses and objectives to the choice of regulatory framework and again to the ‘street level’ implementation is handled in. In the cases where different policy measures are used in combination they can be characterised as a policy pattern.

Waste prevention policies, their interaction with innovation processes and their environmental impact are studied in two ways. Firstly through an analysis of waste prevention actions earlier identified in studies by OECD and EEA, and secondly through five cases which represent different targets of environmental regulation: product, material, waste stream, consumption and sector. In both analyses the focus has been on identifying timelines, the policy regimes around policy instruments and interaction between policy regimes shaping policy patterns of coherent or disperset character.

Waste Flows in the EU

A survey has been carried out on the level of waste generation from production and consumption throughout the EU and its predictable future trends. The coverage of countries, and the resulting quality of information generated is dependent on the data quality available: The waste data systems suffer from gaps and from inconsistency in waste categorization – even on national level from year to year. In general waste statistics historical data are more comprehensive for EU15 than for the EU10. To a limited extent it has been possible to filter obvious errors, and to fill the gaps, and relatively reliable EU-25-level waste stream data is presented. A model-based projection based on a baseline and a low-growth scenario has been used to predict future generation rates, where possible for EU-25, up to app. 2020 for eight different waste streams, which however are different from the way that the waste statistics are organised. The trends project substantial increases in several waste streams.

The detailed set of figures from the above is placed in a separate file on the enclosed CD.

Prioritisation of waste streams and materials from their environmental impacts

In order to identify waste materials and waste streams of main concern for prevention policy intervention, the potential environmental impacts of waste materials have been characterised. Waste streams containing a mixture of different materials have been assessed according to their content of materials. The assessments based on the simplified indicators have been supplemented using quantified using life-cycle assessment software and the impact categories of the EDIP LCA methodology and using the marginal technology approach.

Conclusions at waste material level:

The results obtained illustrate that the materials have quite different intensities of energy and resource use and different potentials for savings through waste treatment like recycling and incineration. Three groups of materials can be distinguished – with the group with the highest potential from prevention first:

- The first one comprises aluminium and plastics. These materials are very resource and energy intensive, and also have high recovery potentials through recycling and/or incineration.
- The next group is composed of cardboard, paper and steel, with medium intensities of energy and resource consumption, and medium potentials from prevention.
- The last group comprises organic matter, glass, textiles (natural and synthetic) and construction mineral materials and wood.

Quantitative prevention actions should preferably target the materials which rank high in the overall priority list due to their amounts in Europe: mainly minerals, cardboard, paper and organic materials. Such prevention actions affect the energy use and the resource use associated to the use of these materials. *Qualitative* prevention actions should focus on materials which rank high because of their hazardousness concerns e.g. through substitution of additives which result in hazards during use, disposal or production (e.g. bisphenol A, flame retardants and softeners in plastics, heavy metals and waste oils in scrap, impurities in aluminium).

Conclusions at waste stream level:

The result shows that among the analysed waste streams, there are five that particularly contribute to environmental impact:

- Total municipal solid waste (contributes considerably to both environmental impact, waste generation and resource consumption and has a high hazardousness score)
- Total manufacturing waste
- Mining and quarrying
- Energy production waste
- Hazardous waste

From a waste prevention point of view, actions that are directed at these waste streams would have the highest environmental gains.

It should be emphasised that the assessments made are based on assessment of materials not including the use stage. When shifting the assessment from materials to products or waste streams, a more specific assessment will be necessary targeting specific products groups to ensure that no sub optimisation is introduced due to the exclusion of the use stage.

Waste prevention actions and policies

The study presents 30 waste prevention cases – described and presented in annex 2 on the enclosed CD. The study covers examples from all over Europe and from a number of different product areas. However the available data are too scarce to allow for identification and in-depth analyses of the effectiveness of the policy regimes involved. The materials/waste fractions containing hazardous substances may be reduced by 'strict avoidance' i.e. product substitution or substitution of chemical substances. In general minimising material consumption is applicable for many materials. Reuse is applicable for e.g. glass bottles and organic household waste depending on national waste definitions. Certain kinds of materials (production waste) may be reused in the same process without leaving the plant.

Substitution of products or chemical substances and reduction of chemical substances often require legislation e.g. ban on chemical substances whereas the other options may be implemented by a number of less strict measures.

A case study within batteries illustrates the timeline from an EU directive to implementation in individual countries and tightening of the limit values in the national implementation together with voluntary labelling schemes where expectations on more far reaching restrictions (total ban of cadmium in batteries) has resulted in development of alternatives to NiCd-batteries.

Waste policies and innovation

Five case studies representing different targets of environmental regulation have been conducted with focus on the interaction between waste minimisation prevention policies and actions and innovation waste handling and on the effectiveness of the policies in terms of reduction of environmental impacts. The five cases cover product orientation (electronics), material orientation (PVC), waste stream orientation (packaging materials), consumption orientation (textiles), and sector orientation (construction and demolition).

More general conclusions about the interaction between waste prevention and minimisation policies and innovation are that:

- waste prevention and minimisation policies have not had a limiting effect on innovations in the cases studied
- policies have created incentives for and also set directions for innovations improving both product improvements concerning materials and production processes used and waste handling technologies, but
- limitations have shown in the cases studied related to a lack of consistency in how policies have been defined, coordinated, and enforced.

On the other hand:

- waste minimisation and prevention policies are not per se encouraging innovations as they often impact products at a phase in their life cycle 'distant' from the responsible designers and producers, and more importantly
- policies explicitly addressing extended producer responsibility need to be designed in a way, which addresses the design and production to prevent waste generation and the related environmental impact, if they shall be efficient in creating incentives for waste preventing innovations.

These general conclusions are though based on the limited empirical material collected in the cases due to the lack of data from international, comparative evaluations of the impact of waste

prevention and waste minimisation policies. But it must also be recognised that the studies needed do are not easily produced.

In general the success of the diverse set of measures supports the importance of coherent policy patterns and the coordination of policies following overall goals communicated clearly, more than the single choice of policy instruments. Extended producer responsibility as well as traditional banning of substances together with economic charges all contribute while each instrument also demands certain conditions to be effective as demonstrated in the case studies.

Many initiatives are not widely disseminated, but only implemented in some countries and among some frontrunner companies, maybe involved in a project or programme. The impact of waste prevention policies is therefore not only dependent of the effectiveness of the measures used and their coordination but also on the dissemination of the policies throughout Europe. Continued negotiation with and pressure on industry concerning setting goals for eco-design and the need for waste prevention seems to be important for producing a positive impact of waste minimisation policies on innovation.

Very few policy instruments and supported efforts are focusing on limiting the amount of product waste by prolonging the life time of the product through 'social innovations' and 'market innovations' including the development of new product-service systems with changing responsibilities based on altered systems of distribution, ownership, and maintenance, which could include the upgrade and repair of products. However, the global production and distribution structures and the growing amount of cheap, but complex consumer products (like electronic products) make waste recycling a challenge, since it is expensive to disassembly and reuse components at their original manufacturing production site. In stead grey-zone export of expired, maybe partly functioning products, to poorly equipped facilities in poor countries are taking place as so-called product export.

Life cycle assessments are used as method in many cases, but often does the available data not allow comprehensive assessments, which may cause controversies among stakeholders within a policy field about lack of data, data quality, system boundaries etc. Life cycle assessments should not be seen and used as 'black-boxed' expert tools, but as tools for dialogue about mutual recognition of data quality, system boundaries etc. A strong policy pressure will be necessary to create a 'feeling' of urgency among the stakeholders. Often life cycle thinking with qualitative assessments may be enough to create a picture of the problems and policy options to be considered.

Data about economic costs and benefits of waste prevention actions for authorities, consumers and industry have not been found. Most data concerns the use of economic incentives in encouraging industry to other types of waste management, for example encouraging recycling and construction waste by increasing the costs for land filling. However, the economic instruments are not the only instrument needed to ensure changes in the waste generation or waste management.

The self-regulating potential of economic instruments has also been questioned by the EU in relation to the EUP-directive, where self-regulation is not seen as a feasible option, in particular in sectors where the market is very fragmented. This is relevant for energy-using products, given the size and lack of homogeneity of the sectors involved; it cannot be expected that credible and coherent voluntary actions of the economic operators to address environmental aspects of energy-using products throughout their life cycle will emerge spontaneously.

Establishment of waste prevention may imply some initial costs to authorities in terms of a waste prevention programme for supporting industry in developing and implementing waste prevention options.

1 INTRODUCTION

The present study is analysing waste prevention actions and policies in the EU member states (EU25) and their impacts on environment and innovation. The study intends to support the dissemination and implementation of innovative waste prevention modes on the European as well as the national and local level to support the intentions of the Commission Communication, 'Towards a thematic strategy on the prevention and recycling of waste', latest adopted by the European parliament (22/06/2006) and the Council of the European Union (27/06/2006).

1.1 Objectives

The study has two separate, but related, objectives: firstly, to identify waste types and fractions that have high potential to reduce adverse environmental impacts due to resource consumption and hazardousness; secondly, to evaluate waste prevention policies and their interaction with innovation.

The first part of the study provides guidance to policy- and decision-makers, by identifying waste prevention actions with a high potential to reduce the environmental impacts of resource use. This is done based on the contemporary available waste statistics in the EU, followed by an life cycle based approach to identify those waste types and fractions that have high potential to reduce environmental impacts and evaluates existing prevention policy cases. The whole value chain is of interest and both quantity and quality of waste streams has been taken into account.

The second part of the study has analysed how the dynamics of innovation can be influenced by various approaches from waste policies and hence, how waste prevention policies could potentially change the environmental impacts from waste. This includes an analysis of how different waste policies and implementation tools influence the dynamics of both technical, social, and market innovations, how waste policies impact different part of the supply chain involved, and which policies patterns and implementations have shown to be efficient.

1.2 Background

Generation of waste is continuing to increase rapidly across the EU. Although for certain waste types a slight relative decoupling from GDP has been noticed in recent years, the environmental problems related to waste generation and waste management are growing. It is clear that the current situation is not sustainable and thus absolute decoupling is needed in order to come to terms with the many severe environmental impacts stemming from waste. Consequently, there is a great need for changes in production as well as consumption and, thus, policies which induce innovation in the area of waste management (including waste prevention) should be sought. According to the waste hierarchy, waste prevention is the first step to strive for and, hence, actions to accomplish this would have a leading role in the way towards a solution to the currently growing waste problem. But also waste minimisation may be a needed second priority to reduce the amounts of waste.

In general, waste generation trends are driven by several factors including levels of economic activity, demographic changes, technological innovations, life-style and patterns of production and consumption. It is a complex issue making it important to tackle waste prevention and management in conjunction with resource management and product policy. This approach has been often overlooked so far.

1.2.1 Introduction to waste prevention

As it will be evident in later parts of the report, both technical evaluations of waste systems and the analysis of policy measures are dependent on stringent and consistent definitions of waste and waste prevention actions. In the present project we apply the OECD definitions on waste

prevention (OECD, 2000), which have been generally implemented by the EC. Waste actions are defined as:

Strict avoidance	“Strict Avoidance” involves the complete prevention of waste generation by virtual elimination of hazardous substances or by reducing material or energy intensity in production, consumption, and distribution”
Reduction at source	“Reduction at source involves minimising use of toxic or harmful substances and/or minimising material or energy consumption”
Product reuse	“Product reuse involves the multiple use of a product in its original form, for its original purpose or for an alternative, with or without reconditioning”
Recycling	“Using waste materials in manufacturing other products of an identical or similar nature”
Waste minimisation	“Preventing and/or reducing the generation at the source; improving the quality of waste generated, such as reducing the hazard, and encouraging reuse, recycling and recovery”.

These three actions are presented in life-cycle context in Figure 1.1. The figure includes the terms *Waste Minimisation* and *Waste Disposal*. Waste Minimisation covers in addition to the waste prevention actions Recycling and Incineration (with energy recovery). Waste Disposal covers Incineration (without energy recovery) and land filling. The categorisation of incineration (with or without energy recovery) varies from country to country. It is also important to observe that by the above definition recycling is a process involving waste, whereas waste prevention occurs before products or materials are identified or recognised as waste.

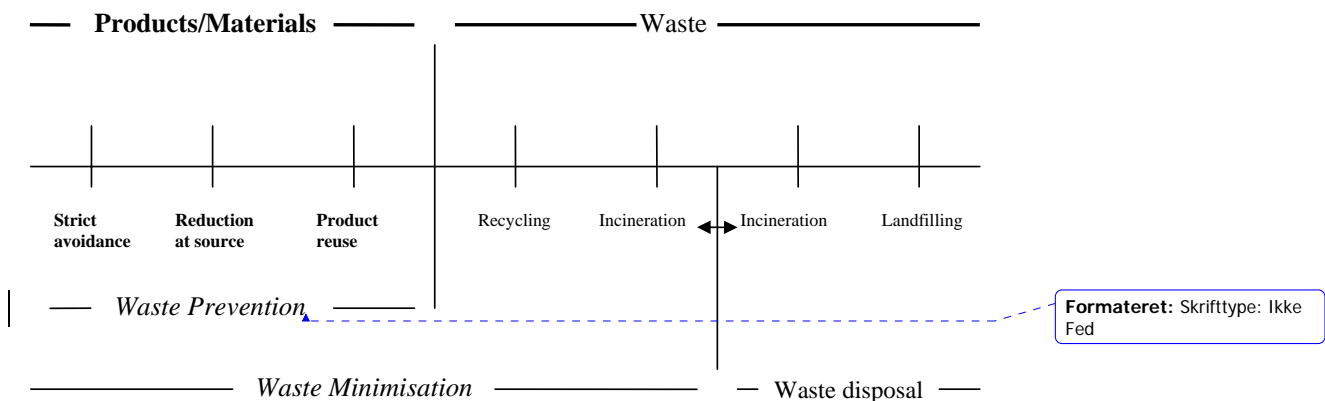

Figure 1.1: Waste Prevention actions in life-cycle context (reproduced from OECD (2000)).

In practice, the overall waste statistics reuse and recycling have the same effect in reducing the waste stream for incineration or land filling (i.e. waste minimisation). A precise distinction made alone from the figures of reductions is therefore difficult. For example, the rather large reductions of waste from building constructions in recent years stem is due to the reclassification of construction waste used for base road construction ‘reuse’ - even though base road construction is not the original use of the material it is considered to be ‘similar’. The example demonstrates the complexity in handling the reuse definition which in practice creates a ‘grey zone’ of interpretations. Classification of certain products for reuse is often also used as an alibi for export of waste to third world countries as e.g. seen in the case of mobile phones and other streams coming from electronics and PVCs. While some parts or products in fact may be reused, other parts of the products are then recovered under potentially dangerous conditions.

The problem with eventual classification is also recognized in the EC paper on the 'Thematic Strategy for Waste Prevention and Recycling' in the discussion about the definition of waste (EC 2005, 12). Further attention on the definition and especially on the enforcement of practices following up on these definitions is needed.

Waste Prevention Actions of the OECD framework are defined with the following sub-parameters:

- Strict avoidance
 - Product substitution
 - Substitution of chemical substance
- Reduction at source
 - Reduction of chemical substance
 - Minimising energy consumption
 - Minimising material consumption
- Product reuse

Definitions on/descriptions of the different waste prevention action are given below. The definition on recycling (waste minimisation) is included for comparison.

Product substitution: Products made from scarce materials or materials leading to significant environmental impacts during the life-cycle may be substituted by products leading to less environmental impacts. Examples are PVC products substituted by e.g. other plastics or rechargeable batteries substituted by e.g. NiMH batteries.

Substitution of chemical substance: Chemical substances may be substituted by less dangerous substances while the function of the product is maintained. Examples are substitution of lead based stabilizers in PVC with stabilizers based on e.g. calcium or substitution of lead driers in paint with driers based on other metals.

Reduction of chemical substance: The content of certain chemical substances may be reduced without changing the function of the product. Examples are reduction (and finally removal) of lead in petrol or reduction of mercury in primary batteries.

Minimising energy consumption: Energy consumption may be minimised either in the production phase or in the use phase. Examples are white goods e.g. electricity consumption by refrigerators or petrol consumption by cars.

Minimising material consumption: Material consumption may be minimised by developing a more efficient technology for production or by e.g. reducing the weight of the product while the function of the product is maintained. Reduced material consumption often leads to reduced energy consumption. Examples are reduction of material consumption for production of cars or reduction of the weight of glass bottles for beverages.

Reuse: Reuse of a product in its original form for original or similar use - with or without reconditioning or repair.. Examples on reuse of products are refilling glass or plastic bottles after cleaning and examples on reuse of materials are recirculation of glass cullet within the same production of e.g. glass bottles. Individual composting of household waste is considered as reuse (contrary to recycling) in some countries as the materials have not reached the curb i.e. has not yet become waste (OECD, 2000). Repair options for electronic products and many consumer products too could extend the life span of products and thereby lead to waste prevention.

Recycling (waste minimisation): Recycling of materials may be use of collected waste materials for other purposes than originally intended – with reconditioning. Examples are use of glass from collected one-way bottles for production of new bottles or other glass products or use of collected mixed plastics for garden benches. Individual composting of household waste is considered as recycling in some countries (OECD, 2000).

In the Commission Communication, 'Towards a thematic strategy on the prevention and recycling of waste', it is concluded that limited progress has been made so far to turn the set objectives of waste prevention into practice. The lack of progress can partly be explained by the absence of comprehensive strategies with credible and effective waste prevention targets, which should be based on assessments of waste generation patterns in different sectors of the economy as well as their potential to actually be reached. Hence, setting up targets as such is not enough. It has to be preceded by an evaluation of possible measures/actions to achieve waste prevention in each case, in order to focus the efforts correctly and to end up with the right targets, both the kind of target as well as the quantitative level. Thus it can be stated that virtually, the sense of strategic planning has not yet been applied on waste prevention.

The complex matters show that there is need for various kinds of waste prevention plans at a range of levels, e.g. the European, national and local with different but complementary focus. They can be elaborated for entire economic sectors as well as for individual enterprises, for pre- as well as post-consumer waste. A number of such initiatives have been launched in Member States at various levels and with varying focus. Moreover, different sectors render themselves to different approaches and levels of waste prevention. Agriculture and forestry are examples of sectors which are normally considered to have lower possibilities to experience decoupling of waste growth from economic growth than e.g. food products, energy supply and construction. Yet another relation can be seen with industrial branches which do not normally need much input material and do not necessarily generate more waste while increasing their added value. These are typically high-tech industries, where reduction or avoidance of hazardous components is generally more important than reduction of waste volume.

1.2.2 Waste policy and innovation

The Thematic Strategy on Prevention and Recycling of Waste, which the Commission is developing, will promote life-cycle thinking in waste policy. Life-cycle thinking should not be static and should as far as possible take into account the dynamics of innovation.

In many cases life-cycle assessments and other scientific methods are used to compare policies and/or waste management techniques. Such comparisons are by their very nature static and do not take into account the dynamics of innovation. However, the dynamics of innovation may conduct to a change in design/production/consumption patterns or techniques which changes the environmental balance of given waste management policies.

An important question is how regulation affects the incentives and ability to change: does it act as a constraint, does it accelerate or delay certain developments and in what ways does it cause a company to do something new?

There exists some literature on the impact of regulation on recycling innovation but less is dealing with the impact of waste regulation on innovation. There is also some research on the impact of general environmental regulation on innovation showing that the technology responses range from the diffusion of existing technology, incremental changes in processes, product redesign, as well as product substitution and the development of new processes. The most common responses to regulation are incremental innovation in products and processes and diffusion of existing technology.

1.3 Project outline

The project has been based on information and data available in existing literature, regarding industrial and municipal waste and on semi-quantitative and quantitative environmental analyses applying life-cycle assessment (LCA) or life-cycle approach as allowed by data availability. Built on that, the project has developed and applied a methodology for the

assessment of waste prevention actions regarding their impacts on, and relationships with, sustainability criteria, policy development and innovation.

The study has been organized in seven interrelated work packages each having assigned work package leaders, demanding a close cooperation between the consortium partners. The work packages have been defined as follows:

- WP1 is a data collection study - a survey on waste generation, composition and management in EU, managed by The Regional Environmental Center for Central and Eastern Europe, REC.
- WP2 quantifies the environmental impacts from the treatment of waste streams, managed by The Danish Topic Centre on Waste, DTCW.
- WP3 collects information on prevention actions and strategies, managed by the National Environmental Research Institute in Denmark.
- WP4 develops a methodology framework to evaluate the environmental impacts of waste prevention actions and the impacts on innovation, managed by Department of Manufacturing Engineering and Management, Technical University of Denmark.
- WP5 calculates and analyses the potential environmental impact savings derived from the waste prevention actions and strategies collected in WP3, managed by Department of Manufacturing Engineering and Management, Technical University of Denmark.
- WP6 analyses the links between waste management, waste prevention policies and innovation, managed by Department of Manufacturing Engineering and Management, Technical University of Denmark.
- WP7 is the final reporting, managed by Department of Manufacturing Engineering and Management, Technical University of Denmark.

The working process is illustrated in figure 1.2 – as indicated by the arrows the process has to a great extent been iterative.

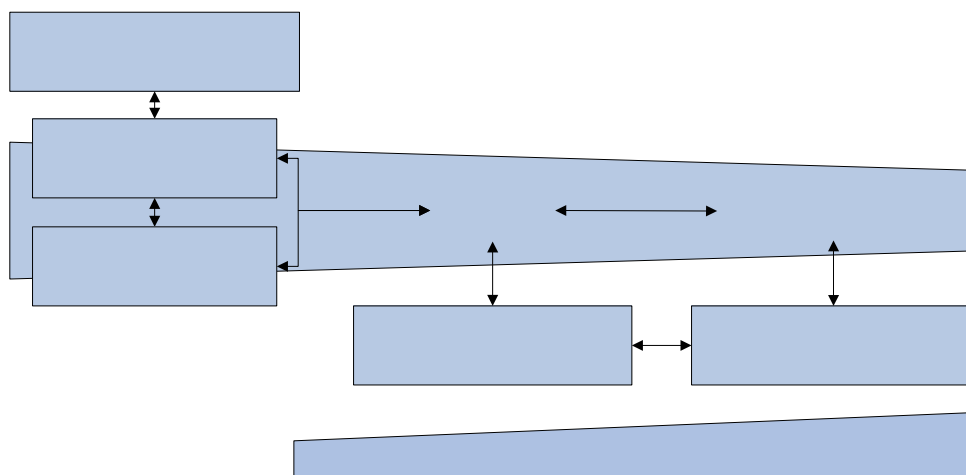

Figure 1.2: Project flow diagram.

While WP1, WP2 and WP3 has been designed and implemented as general surveys, the results and experiences gained throughout these initial workpackages as well as the inputs from the advisory workshop have made it possible to focus efforts in subsequent workpackages to dedicated areas. Thus WP5 and WP6 are focusing on different levels of waste prevention and innovation actions structured around selected cases in order to be able to provide the wide spectrum of possible actions.

1.3.1 Case selection

Especially the policy analysis in relation to innovation had to be focussed on areas where policy evaluations and innovation studies were available while at the same time covering the broad spectrum of policies and problems at play. The choice of areas also involved an identification of areas with potentially high environmental impacts from waste prevention. Consequently the following waste prevention policy levels have been applied and also used as the outset for the choice of cases for detailed study in the policy part of the project, but also structuring parts of the presentation of waste flow and hazardousness data and life cycle assessments:

1. **Product oriented:** Electronics – RoHS, WEEE, EoLV – including areas of product and process regulation for hazardous substances and waste handling - producer responsibility, and take back policies.
2. **Material oriented:** PVC - regulation of the use and substitution of PVC and additives including the different policy controversies and stakeholder activities.
3. **Consumption oriented:** Household waste focusing on textiles – including policies related to the design of these products and influencing product chains.
4. **Sector oriented:** Building materials including minerals, isolation and glass – including the problems of redefining waste streams.
5. **Waste stream oriented:** Packaging waste – plastic, paper and cardboard, glass

The selection of cases has been done from a gross list of waste prevention cases, all including a waste policy segment and a segment of innovative waste handling. The selection was done based on this gross overview and supported by the inputs coming from the expert advisory workshop arranged in Copenhagen on 23 May 2006. The arguments for the selection of cases are presented in detail as part of the analysis in the relevant chapters on environmental impacts (Chapter 4) and policy innovation interactions (Chapter 6).

1.3.2 Expert workshop

At the work shop a number of invited specialists on waste prevention, policy and innovation participated. The workshop ensured that the developed framework and the case studies selected were able to cope with the diversity of national contexts in Europe, and that links between waste policy and/or management and innovation were fully explored across the EU. Table 1.1 presents the invited specialists and the title of their presentation at the workshop.

Table 1.1: Specialists for the work shop the 23rd of May 2006 in Copenhagen.

Specialist	From	Presentation
Stefan Salhofer	Abt. Abfallwirtschaft, Uni. für Bodenkultur, Vienna, Austria..	Experiences and learning's from waste prevention activities
Sophie Marguliew	Espace Environnement NGO, Belgium.	Input from the project REDUCE, and the analysis of EU waste prevention
Ester van der Voet	Inst. of Environmental Science, Leiden Uni., The Netherlands.	Thoughts on evaluating waste prevention
Julian Parfitt	Waste and Resources Action Programme, United Kingdom.	Waste prevention in municipal waste streams
Gerhard Vogel	Wien Uni., Product management, Austria.	Dematerialization and Immaterialisation
Ignasi Puig Ventosa	ENT Environment and Management, Spain.	Economic instruments to foster waste prevention

Finally the workshop also contributed to the study significantly in obtaining general comments and suggestion on the study drafts.

1.3.3 Definitions used in the study

Waste prevention aims at reducing the adverse environmental and human health impact of products or materials before they enter the waste stream, and comprises the following three elements: Strict avoidance, Reduction at source and Product re-use.

Waste prevention actions are the concrete ‘projects’ and activities actually implemented by producers, consumers or other actors aiming at preventing waste generation, whereas *waste policies* are the political (set of) measures and instruments that have induced the implementation of the concrete actions in order to fulfil certain political targets.

Environmental impacts are life-cycle impacts and thus include impacts from resource extraction and transformation into marketable goods (including impacts from their use) as well as impacts from waste treatment, recovery and disposal.

Innovation in relation to waste generation and management refers to the idea of a positive conversion, which introduces new ideas or procedures within the consumption, production or treatment of a product that have an impact on the waste generated (e.g. amounts or hazardousness).

In this study, focus is on the innovative initiatives (e.g. organizational, technological, procedural or social) that have been stimulated by current waste policies (and hence not innovation within policies). *Market innovations* refer to the idea of a conversion that occurs as a result of business activities changing the way products are sold, distributed and serviced and *social innovations* refer to the idea of a conversion that occurs resulting in changes in user patterns and organisational matters of importance for social practices in production and use resulting.

1.3.4 Data quality and the interpretation of LCA results

The scope of the study implies use of waste statistics figures as input for life-cycle analysis of waste streams, to be able to put focus on the environmentally most significant waste streams, and to be able to identify related waste prevention actions and policies. However, waste streams and waste types are complex composites of many different fractions and products, and the statistical figures are most often impossible to break down to the material and resource level which is needed as an inventory for the LCA. At best the entry for an LCA is an inventory on used materials and resources to be able to quantify the environmental impact potential. In addition, to be able to do an LCA it is necessary to define a specified scenario of the life cycle of the object, which implies that the resulting assessments only can be used for comparative purposes, not to be look upon as absolute figures. These gaps in data requirements and coherence and in the multiple possibilities in the definition of the life cycle of the very same object, has required the establishment of a well defined and documented methodology, and attention has to be paid to this to avoid that results are over-interpreted.

1.3.5 Report structure

The report reflects in most ways the project flow diagram in figure 1.2, apart from that WP4 – the methodology development - has been placed as the first substantial chapter in the report – chapter number 2.

The structure of the report is sketched out in the overviewed in Figure 1.3.

Ch. 2: Methodological framework and project approach - Development of a framework of indicators and scoring and ranking systems that can be applied in diverse waste/resource management conditions
Ch. 3: Waste flows in the EU - A survey of waste composition and generation on EU member state level. Both industrial and household wastes and both total current and future waste amounts.
Ch. 4: Environmental impacts of waste streams – identification of prevention potential - assessing the environmental impact of the identified waste fractions in Ch. 3 in a qualitative manner as well as with an internal ranking of the fractions in terms of their environmental impact.
Ch. 5. Existing waste policies and actions – A survey on policies and actions for waste prevention of both municipal waste, e.g. change of consumer behaviour and of industrial waste, e.g. cleaner processes.
Ch. 6: Case studies of the impact of waste prevention policies on innovation & environment – analysis of how policies related to waste management and waste prevention have affected innovation within 5 selected significant types of waste generating entities and the potential environmental benefits of the policies
Ch. 7: Conclusions and Recommendations

Figure 1.3: Report structure - including a short introduction to each chapter.

1.4 References

Towards a thematic strategy on the prevention and recycling of waste: [OJ C 76, 25.3.2004](#); COM(2003) 301; Bull. 5-2003, point [1.4.37](#). Commission communication to the Council and the European Parliament.

Taking sustainable use of resources forward: a thematic strategy on the prevention and recycling of waste

EC (2005). COM(2005) 666 final. Communication from the commission to the council, the European parliament, the European economic and social committee and the committee of the regions.

Taking sustainable use of resources forward: A Thematic Strategy on the prevention and recycling of waste. Draft report, Johannes Blokland. (22/06/2006). European Parliament - Committee on the Environment, Public Health and Food Safety.

Conclusions on the prevention and recycling of waste. The 2740th Environment Council meeting, Luxembourg, (27/06/2006). Council of the European Union.

2 METHODOLOGICAL FRAMEWORK AND PROJECT APPROACH

The present chapter presents the overall methodological framework of the waste prevention analysis. The project combines two analytical traditions: One the technical life cycle assessment approach where the impacts of waste streams are analysed with waste stream mapping as input, and second the classification and evaluation of policies relevant to waste prevention and innovation processes with mapping of generic policy measures as input.

Ideally a rational framework to assess the actions and policies addressing waste prevention and should answer two questions: What are the potential environmental impacts of these policies and actions from a life cycle perspective? And how do policies and actions contribute to the prevention of waste as well as the performance of the innovation? This could be established as a two step approach where the life cycle assessment of waste streams would be used as the input for a policy analysis in order to provide a description of causal relations between policy measures and reductions in environmental impact from waste streams. However, the complexity of waste streams and innovation processes makes it impossible to follow this ideal model in practice.

In practice life cycle methodologies require much more substantial data on the composition and fate of waste streams than are available at present. Furthermore the inherent problems of LCA with regards to combining assessments of different types of impacts and effects to common indicators cannot be solved. Equally, with the exemption of cases where single compounds are targeted, it is very difficult to attribute specific waste reducing effects to particular policies as the changes in the size and composition of waste streams are affected by combinations of multiple policy measures and initiatives.

Thus the two approaches are not intrinsically linked in this project, but rather function to complement each other. The following section includes an introduction to the necessary considerations and limitations of the two approaches when they are applied to the practice of analysing waste streams and waste prevention measures.

The section on environmental impact indicators gives an overview of different indicator types and describes the application of indicators in the present study. As shown in the report, specific local choices, transport distances, waste management technologies and many other local circumstances have a large influence on the impacts of specific actions. The aim of this study is therefore not to provide final solutions to policy makers and waste managers, but to inspire and provide a background on important issues that need to be included in the consideration of specific waste prevention actions.

In order to reveal all impacts and reduce risks of for example preventing waste in one stage of the life cycle at the expense of an increase of waste or other impacts in another life stage it is essential that a life cycle perspective is applied in the framework. That is potential impacts of raw materials extraction, production, product (use) and waste (recycling/incineration/landfilling) as exemplified in the figure 2.1. The use of waste or material flows alone as indicators is not appropriate in this context since it is the aim to identify potential environmental impacts. If only mass flows of waste or materials were included it would provide a skewed representation of the environmental impacts. The environmental impact of extraction and use of for example aluminium are much higher than those for gravel.

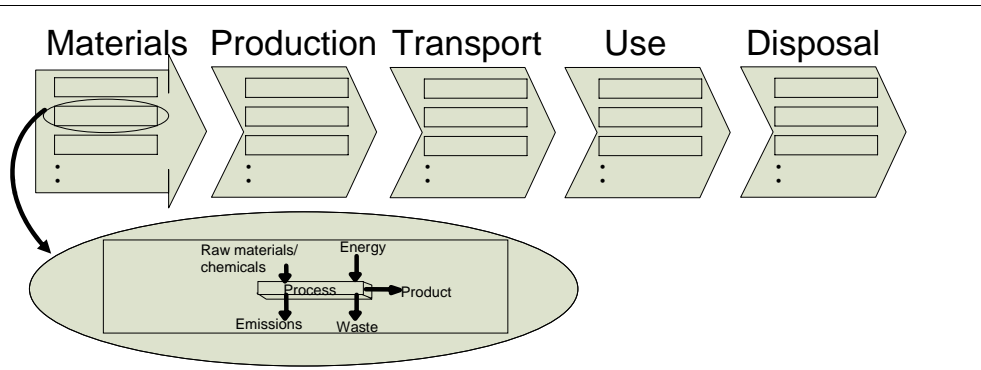

Figure 2.1: The life cycle of a product and the environmental exchanges related to each process.

The section on policy analysis framework outlines the problems of policy analysis and presents some theoretical considerations on the multiple roles of governments, policy patterns and styles, empirical and model based studies of policy instruments, regulatory regimes and the institutional context, and innovation policies. The policy analysis is applied in the study on waste prevention and its impacts on innovation.

This part of the methodology framework aims to analyse, for a given policy/action what kind of influence on waste generation is obtained and if possible how much waste is being prevented as a consequence. This may be from empirical data or model based as will be the case in some of the life cycle assessments and policy considerations. Since we are dealing with policy patterns for which cause-effect relations are rarely simple it is unlikely to attain a quantitative measure for the effects of the policy/action – even indicators are difficult to establish. However the objective is to construct qualitative measures and build advice based on experiences from case studies on waste prevention. Policies and actions that target different stages in a product or material life cycle may be involved.

2.1 Environmental impact indicators

Waste prevention is, to a high extent, connected to the thematic strategy on the sustainable use of resources. The thematic strategy has been developed and disseminated in a commission staff working document (EC, 2005b), which stated that further work is needed on the development of lead indicators for resource productivity, resource specific impacts, and eco-efficiency, although some work has already been done e.g. in a project for DG-ENV on development of indicators to assess decoupling of economic development and environmental pressure (van der Voet et al. 2005). The mentioned project uses life cycle assessment tools to evaluate and quantify the environmental impacts related to the use of materials in the European economy.

The methodological framework proposed in the current project also aims to evaluate the environmental impact potential of waste prevention in a life cycle perspective. Either as ranking using resource specific impact indicators (coupled with waste-type hazardousness indicators) as common denominators for environmental impacts of a waste flow or including a full life cycle impact assessment providing the potential impacts of the systems. This means that it is not only the impacts caused by waste handling but also the impacts that the products (waste flow) have caused during extraction of raw materials until final disposal, when the material is lost from the economic sphere. Therefore impacts related to the extraction and the following losses of the materials are included. It depends on the object of study whether or not the use stage of the product cycle should be included in the analyses. If we study a functional unit, i.e. the service that a specific product delivers to society, the use stage must be included. However, if the object is a waste/material stream, resulting from many different types of activities (e.g. packaging), it is not relevant to

include the use stage, primarily because it is not possible to identify the specific impacts in the use stage, since these are ambiguously related to the materials used in the products

In the commission staff working document (EC, 2005b) an open stakeholder consultation, commented by industry, member states, and NGOs, revealed the following comments concerning environmental impact indicators:

- *NGOs were generally supportive and wanted indicators linked to environmental impacts. Member states and industry were split.*
- *Concerns remain about aggregation; the integration of the whole of a material or product life cycle; the feasibility of developing environmental weightings and concern that policymakers may rely on indicators, while these may not give the full picture.*
- *Barriers to the development of indicators were identified as: accuracy, comparability, burdens on data suppliers, data reliability, cost, access to life-cycle inventories (LCI) data, how up-to-date information; how to measure; weighting environmental impacts; hidden flows; confidentiality; gaps; different sectoral structures. But there were no positive suggestions as to how these could be overcome.*
- *Some stakeholders preferred a basket of indicators.*

These comments are valid also for the indicators to be used in the current study, it is therefore important to stress in the description of a methodological framework that there will be uncertainties attached to the indicators related to the aspects mentioned above. The results of using LCA for assessment of waste streams should therefore be considered of a comparative nature rather than absolute

2.1.1 Indicator types

The impact assessment parts of LCA methodologies, developed during the last decade, have addressed the pressure-state-impact part of the DPSIR cycle extensively, and in principle most often use efficiency indicators. Much research and development effort has been channelled into the understanding of this part of the DPSIR cycle, but though work has also been done on the link from responses over driving forces to pressures only few useful results have been seen here, and reports often conclude in more work to be done as discussed above.

The environmental indicators developed in this study are based on previous studies in this field. Several reports using a wide array of indicators have been studied (van der Voet et al., 2005; Poll et al., 2005; UN, 2006; Harjula et al., 2004; New Zealand Ministry for the environment, 2000). However, most indicators do not address the P-S-I targets of the waste sector in a detail that is adequate for our purpose, since they do not address the potential environmental impacts sufficiently. One reason for this that has also been encountered in this study may be that waste streams are generally composed of many different fractions that each possess their own environmental impact potentials.

2.1.2 Environmental indicators for waste prevention

The environmental indicators to be used in this study are subject to a basic requirement: They must indicate the environmental impacts of a waste prevention in a life cycle perspective, i.e., it must be possible to see to which extent the prevention action reduces environmental impacts, caused by the possible savings of materials production and by the avoided waste handling. This entails that a life cycle perspective needs to be applied.

The Life Cycle Assessment principles of assessing the entire life cycle of a product from extraction of raw materials to the final disposal should be applied. However, one important difference is that whereas the traditional LCA has a functional unit as object (most often the services provided by one product), the LCA to be applied for the current purpose will, in most cases, have a waste stream or a resource as the object of assessment, since our focus is on waste or material flows. The objective of the assessment is thus to compare different waste prevention options (policies and actions) in terms of the environmental improvement they will instigate, not to examine the environmental impact of a service.

One problem that has been encountered during this study is that waste flows as they are known in waste statistics are all rather diverse with many different fractions that each has their own environmental impact profile. Furthermore, waste prevention actions will in most cases not be related to a waste flow but either to products or to materials. Off course there are exceptions to this, e.g. packaging which consist of a wide range of materials and for which actions have been taken collectively. However, in most cases focus will be on products or materials for which it is also possible to perform life cycle assessment. In this project the life cycle approach has been applied to materials that generally encompass a large fraction of the overall waste flow.

Most of the existent data on waste relates to waste streams, and not to waste materials, be it of municipal or industrial origin. The difference between these two terms is that waste streams are more aggregated and to a large extent consist of varying mixtures of waste materials. The breakdown of the material components in a waste stream can be carried out at different levels of detail, the extreme case being a breakdown at chemical substance level.

In some countries it is possible to deduce the flows of materials if detailed information about waste streams exists. For instance, it is possible to estimate the total amount of PVC waste of municipal origin if reliable statistics of MSW and separately collected streams that may contain PVC exist assuming that it is then possible to estimate with sufficient certainty the content of PVC in these streams.

Some options for assessing environmental impacts are listed below that may be used separately or combined depending on the purpose of the assessment. In case the assessment of a specific action is warranted, a full life cycle impact assessment will be suitable since a more detailed overview of the impacts is provided. This can be combined or substituted with a literature review including a systematic interpretation and comparison of the results if the particular waste stream is well investigated. Finally, for the purpose of an environmental ranking of different waste streams, a set of simplified indicators has been developed.

The first option for making full life cycle assessment has the advantage of freedom in setting of system boundaries and choice of impact assessment methodologies, data base etc. Furthermore the results can be expressed as impacts on different impact categories. Evaluating other studies (if several studies are available) has the advantage of representing a broader perspective and not being as sensitive to the choices of a single study. However, care must be taken to evaluate e.g. system boundaries and other choices made by the study conveyor. Also the results cannot always be expressed in impact categories but as a relative impact (related to the other studies evaluated).

Of course there is also the more time consuming path to analyse and extract the inventories from already published studies. These will however, most often not be provided in detail for each single process but only for whole or parts of systems if published at all, which means that some of the choices made by the original study conveyor will be taken over. Finally, a literature study can be used to qualify the results obtained from performing an LCA.

2.1.2.1 Indicators based on performing a Life cycle impact assessment

The life cycle of a material in waste, as illustrated in figure 2.2, distinguishes the waste management system (dotted borderline) and the three output flows out of this system that can potentially feed back into the upstream life cycle stages: reused materials, secondary raw materials and surplus energy. In life cycle assessment of waste a number of steps needs to be taken. These are (modified from Villanueva et al. 2006):

- Definition of waste management scenarios and quantification of mass balances of waste materials. It is necessary to collect information about the waste material flows, how these are distributed in waste streams and how they are treated in the system studied. Alternative scenarios can be set up, including non-existent treatment options. In the current study, this information is collected in chapter 3 and a number of archetypical treatment scenarios for Europe are developed in chapter 4. Since in waste prevention actions a number of options will involve either production of secondary materials replacing virgin materials or other reduction in use of virgin materials, also the extraction of raw materials and production of materials needs to be included.
- Quantification of pressures. It is necessary to quantify actual (or estimated) pressures such as emissions, energy inputs and outputs, and resource inputs resulting from all the processes included in the system. The auxiliary inputs to the system such as energy and auxiliary materials have to be defined. This step is performed in chapter 4 for a selection of material streams.
- Selection of impacts and use for prioritisation. Data has to be provided on life cycle impacts, that is, how the pressures from waste treatment are connected to impacts (for example, how to calculate the eco-toxicity and eutrophication impacts of a leachate emission of $x \text{ mg/l}$ of NO_3^- from a compost pile to a river). A representation of the impact assessment sequence is given in figure 2.3. The environmental impacts to be used as prioritisation criteria have to be selected and quantified. The selected indicators need both to be representative of the life cycle impact of waste materials, and to be workable, i.e. it has to be feasible to collect and process the data necessary to use them.

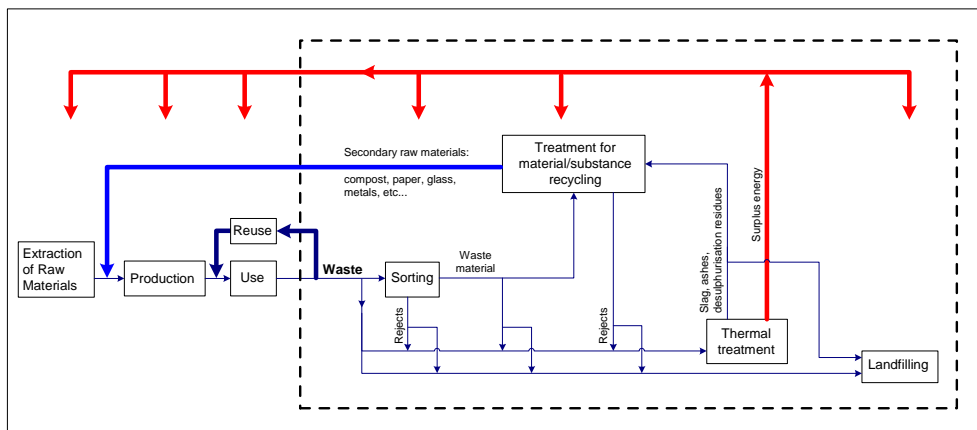

Figure 2.2: Illustration of the life cycle of a waste material. Note that prevention actions are those taken to avoid waste in the areas to the left of the dotted line, i.e., in the extraction, production and use stages.

The type and magnitude of the impacts from the treatment of waste materials depend on three main factors:

- 1) The specific properties of the waste stream (composition of materials, inherent hazard of the substances in the material);
- 2) The treatment technology used (e.g. incineration, recycling), and the effect that the use of the technology has on the environmental pressures;
- 3) The effect that the pressures, once released to the environment, have on humans and ecosystems.

Several methodologies have been proposed by LCA experts (UNEP, 2003) to transform quantitatively pressures into impacts. There is consensus (ISO, 2000) in distinguishing the phases of classification, characterisation, normalisation and weighting in the Life Cycle Impact Assessment. The environmental indicators in different LCA-methodologies can be defined at different points in the cause-effect chain as shown below in figure 2.3, which includes some examples of pressures, midpoint and endpoint indicators. As mentioned before, a holistic impact assessment does not only depend on the type of waste and technology applied, but also on specific geographical boundary conditions that describe quantitatively the differences in how pressures specifically affect the local or regional environment. Generally speaking, endpoint indicators are most environmentally relevant but indicators of earlier steps in the cause effect chain are more certain. There is a trend towards using endpoint indicators and trying to develop assessment procedures and models that provide more certainty. However, only few methodologies have as yet implemented endpoint approaches and some of them are strongly debated. Most common is hence still the midpoint approach using impact categories as shown in the figure.

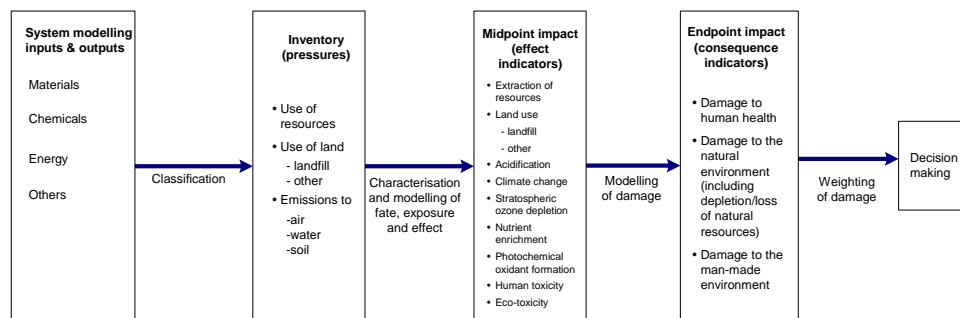

Figure 2.3: The life cycle impact assessment sequence (Villanueva et al., 2006)

In general, data representing manufacturing of the chemicals which are used in materials and products (upstream processes) is rather scarce and uncertain, and it has been demonstrated, that when more emphasis is put on retrieving or estimating the data for the upstream processes, these are often associated with a rather significant environmental impact that is generally not accounted for e.g. (Geisler et al., 2004) (Andersen & Nikolajsen 2003), particularly as regards the human toxic and eco-toxic impacts. Therefore, uncertainties regarding the data base representing the materials cradle to gate data can be large, especially when considering toxic impacts. Data on energy and materials' use is considered to be more complete. Data on waste management practices are also to some extent scarce, especially as concerns emissions from different treatment options. The overall inventory of emissions in materials production and waste management is therefore associated with some uncertainty.

In the current project the LCA-software GaBi including the professional database will be used for the quantification of inputs and outputs during the extraction of materials and the waste management. During the past 10 years the GaBi Software system has been developed in an on-going process of cooperation between the PE Consulting Group (PE) and the University of Stuttgart

(IKP). The reason for choosing GaBi for the purpose of this project is that the tool is flexible and can be used to model complex systems and flowcharts. GaBi has furthermore a set of integrated databases with data on predefined life cycle processes and impact assessments.

Amongst the databases used in this project is also the so-called professional database which includes approximately 650 sets of data, mainly 'cradle to gate' information on resource extraction and emissions in product manufacturing. These data sets have been generated by IKP/PE and are based on information from patent/specialist literature and industry. Processes from the professional database have been used to a limited extent in this project.

The impact assessment will be performed using the EDIP methodology (Hauschild & Wenzel 1998). The EDIP methodology is consistent with the ISO (2000) standard and includes 8 impact categories: global warming, stratospheric ozone depletion, photochemical ozone formation, acidification, nutrient enrichment, eco-toxicity, human toxicity and resource consumption. Landfilled waste is represented as separate impact categories as the amounts of bulk waste, slag and ashes, and hazardous waste. The EDIP methodology is one of the best documented impact assessment methodologies available. Furthermore, the implementation of this impact assessment methodology into GaBi has been through a comprehensive quality assurance by the Danish LCA center (www.lca-center.dk).

It has been shown in other projects (Dall et al., 2003b and Villaneuva et al., 2006) that assumptions in the waste treatment scenarios have large influence on the results of LCAs performed on waste management and prevention. Especially, scenarios regarding energy recovery from waste have a major influence; it is of importance what energy production technology is assumed to be substituted by the energy produced from the waste treatment. As described in Chapter 4 it is chosen here to use marginal technologies i.e. a market based evaluation of which technologies will be employed or dismissed if energy production increases or decreases, respectively. Earlier studies (Weidema 2003) have shown that the European marginal energy technology is coal-fired power plants. It is furthermore shown that there is a surplus of produced heat and therefore no environmental impacts are allocated to heat production as suggested by the Danish guideline (Schmidt & Stromberg 2006).

The EDIP methodology is explained in detail in (Hauschild & Wenzel 1998) for each of the impact categories. In order to improve communication of the indicators and facilitate interpretation and comparison of different impact scores, the different impact scores of a waste management system are brought on a common scale by relating them to the background load from society's total activities, expressing them in normalised form as in the unit of person equivalents (Stranddorf et al., 2003). For global impacts like global warming, stratospheric ozone depletion and non-renewable resource consumption, the total annual global impact in a reference year is divided by the number of persons on earth to calculate the person equivalent. For regional impacts (acidification, nutrient enrichment, photochemical ozone formation, eco-toxicity and human toxicity) the impacts and number of people per region (e.g Europe) is used. The normalised impact profile of a waste management system is determined by dividing each of the impact scores for the system by the relevant person equivalent.

A weighting step may be included in the EDIP methodology based on a distance to a politically set target principle (for example the aims to reach the Kyoto protocol). Weighting factors for both Danish and EU policy target have been developed. For EU policy targets the weighting factor does practically not deviate much from 1 and as such will not be very different from an equal weighting of the impact categories. Equal weighting of impacts is chosen in this project as was done in the CML report (van der Voet et al., 2005).

2.1.2.2 Evaluation of available literature studies

For many materials and products especially in sectors like packaging there is already a vast amount of LCA-studies performed. To take advantage of such earlier studies and the results obtained, these studies can be reviewed. However, care must be taken to understand the goal and scope of such studies to be able to interpret the results properly in relation to the goals of such a review and some sort of methodology would be beneficial.

A methodology for such a comparative review was developed in a recent study for Waste & Resources Action Programme in the UK (Wenzel et al. 2006) in which a comparison was performed on a vast amount of LCA studies on different options for waste management of seven different materials (Glass, wood, paper and cardboard, plastics, aluminium, steel and aggregates (construction waste)). An extensive literature search was performed identifying several hundred of potentially relevant references, from which 55 were selected for a more detailed review. Each of the reviewed studies was a comparison between two or more waste management options. Each study comprised one or more scenarios of varying system boundary conditions and assumptions, each one being an LCA in its own right.

Across the 55 studies the assumptions that were found to be most critical to the results were those that related to the interdependency between waste handling systems and the energy system of the surrounding technological systems including:

- the type of energy used for the manufacture of primary materials;
- the type of energy used for the manufacture of secondary products from recycled materials;
- the type of recycling process applied.

It was found that from 188 scenarios that included recycling, the overwhelming majority of them (83%) favoured recycling over either landfill or incineration. The environmental impact categories that featured in the review included energy use, resource consumption, global warming potential, other energy-related impacts, toxicity, waste generation and other impacts (such as on land use or biodiversity).

The study developed a method for dealing with the complexities of LCA outputs through the use of summary graphs to represent the findings across different scenarios and environmental impact categories. An example is given in Figure 2.4, where results for greenhouse gas impacts for paper and cardboard is displayed, using the following method.

In order to explore the relative environmental benefits of whole life scenarios containing different waste management options, each scenario was represented by a numbered box, the first digit indicating the number of the study and second, the scenario within it. These were then placed along a scale of relative environmental burden, indicating which option had either more or less environmental burden than the other. If one scenario came up with a value within the same range as another, the boxes were then stacked in columns, indicating the frequency distribution of the results across the entire review for that particular material, impact category and waste management comparison.

Particular attention was given to quantification of the greenhouse gas implications of different scenarios, measured as CO₂-equivalents. In line with the overall findings, it was concluded that for paper/cardboard, plastics, glass, steel, aluminium and aggregates there was generally a greenhouse gas emission saving from recycling compared with either landfill or incineration.

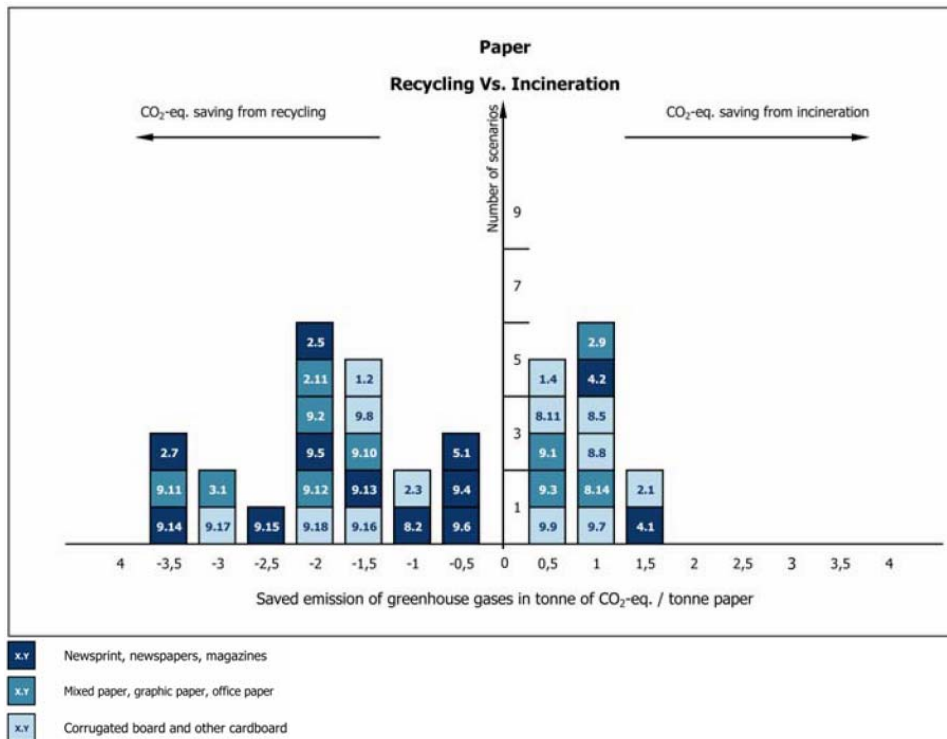

Figure 2.4: Paper and cardboard ~ comparison of whole life cycle greenhouse (Wenzel et al., 2006)

The methodology used in this review and illustrated above makes use of already existing studies many of which to a large degree will be based on much of the same data bases as will be available in different software. It may therefore be useful as a way of using available studies to either directly make conclusions or to qualify an LCA being performed on the same issue.

2.1.2.3 Simplified waste life cycle indicators

For the purpose of an environmental ranking of different waste streams, a set of simplified indicators must be developed. Previously a range of different environmental indicators have been proposed for life cycle assessments by LCA experts (UNEP, 2003). The purpose of the indicators is to aggregate different pressures into impact categories and thereby expressing with a limited amount of indicators the environmental impacts of a system. Indicators at different steps in the cause effect chain have been proposed ranging from midpoint indicators reflecting the effects on e.g. global warming or human toxicity, to endpoint indicators reflecting impacts that are of intrinsically of value to society (human health, loss of natural environment values (e.g. biodiversity or resource depletion) and damage to manmade environment).

In order to account for all effects on the environment, a wide range of impacts must be considered. The conversion process from midpoint impacts to endpoint impacts is complex and currently speckled of knowledge gaps (UNEP, 2003). This is in contrast with the requirements for having a simple, operational indicator of environmental performance that can be used as support for policy formulation. Given the complexity of making life cycle based environmental impact assessments, the need for a simplified approach emerges if life cycle thinking is to be made operational as an input to policies.

A life-cycle indicator such as the midpoint and endpoint indicators in Figure 2.4, aims at capturing in a single value some of the environmental pressures created in the life cycle of a waste material, a product or a system. To obtain an overall picture of the environmental impact in the whole life cycle, using a minimum of indicators, there are three possibilities:

- 1) To aggregate the indicators, understanding that aggregation requires a form of reference to common units. The conversion of inventory pressures to impacts can consist of two aggregation steps:
 - a) Characterisation to midpoint indicators, cf. figure 2.4 e.g., all gases contributing to climate change, expressed in CO₂-equivalents;
 - b) Optionally, normalisation and weighting steps that aggregate midpoint indicator values, and quantify the relative importance of e.g., global warming compared to toxicity or to resource consumption. Several weighting methods have been proposed, for instance based on political targets, or on the result of panels of experts and policy-makers (UNEP 2003, Wenzel et al., 2000).
- 2) To select some of the indicators, and assume that the selected group is a good proxy of the environmental burden or in other words that the relative weight of the rest of the impacts is small or they are well represented by the selected indicators. This is, in practice, equivalent to assigning a weighting value of nil to the non-selected indicators, and a positive value (equal or different for all impacts) to the selected indicators.
- 3) To select indicators of pressures from the inventory or pre-inventory phase of the environmental impact sequence (left hand side of figure 2.4), and use them to establish comparisons between scenarios before any conversion is made to midpoint or endpoint impacts. This way of proceeding is only justified if the two scenarios or systems compared have identical conditions regarding fate, exposure and effects of the chosen pressure, e.g. the SO₂ emissions from the chimneys of two close located waste treatment facilities at the same temperature and chimney height.

Adopting the second of these three possibilities, three simplified, life-cycle based, environmental indicators are proposed to represent the overall environmental impact of the studied scenarios: an *energy indicator*, a single *resource indicator* to be divided into, and referring to energy and material resource volumes, and a *hazardousness indicator* referring to potential risks related to toxicity/hazard and occurrence.

The indicators are situated differently in the sequence of assessment of impacts (figure 2.4). Energy use is an aggregated, pre-inventory parameter that triggers a chain of linkages to pressures (extraction of energy carrier resources, emissions from fuel combustion processes) and impacts (acidification, global warming, resource depletion), the magnitude of which depend on better or worse known geographical and technological case-specific conditions. The consumption of resources and landfill space are midpoint indicators which have clearly identifiable causality linkages to pressures (net use of resources, net generation of waste to landfill) and endpoint impact indicators (loss of resources, loss of land for other uses).

The three indicators were chosen on the basis of a series of criteria that include (Dall et al, 2003a):

1. Maximum possible information representative of the impacts of waste;
2. Data have to be available via e.g. national waste statistics, and it has to be possible to update the indicator in a short time period in order to allow its use in policy;
3. The three indicators chosen are complementary (i.e. no overlap in coverage), and they can serve as proxies of other environmental indicators.

Few existing studies include discussions of the indicators that have most relevance for the impact assessment of waste and resources. Dall et al. (2003b) proposed in their study for the Danish Environmental Protection Agency the use of three LCA-based indicators to identify the potential for environmental improvement of waste material diversion from landfills.

In the study of Dall et al., the proposed indicators are partly overlapping with what is applied in this study: Net resource consumption (measured in normalised units (for instance, Person equivalents¹/Functional unit) or weighted units (Weighted person equivalents²/Functional unit)); Net primary energy consumption (measured in GJ/Functional unit) and Net landfill volume requirement (measured in normalised units (Person equivalents/Functional unit) or weighted units (Weighted person equivalents/Functional unit)). Instead of the landfill volume requirement (which is easily modelled but of limited importance compared to other waste-related impacts), the hazardousness of the waste is addressed by the third indicator in the present study. The indicators are briefly described in the following sections.

Energy indicator

The energy indicator is chosen because all extraction, manufacturing and waste treatment processes require or release energy. Following principles of thermodynamics, the energy and auxiliary materials used for the generation of a material will always be larger than what the material itself bears or can release via recycling.

Energy use/consumption is a pre-inventory indicator, i.e. it does not transmit information of the final exchanges with the environment, in contrast to the pressures, midpoint or endpoint indicators to which it is connected (such as global warming, eutrophication, resource consumption or acidification). This means that some double counting takes place between the energy indicator and the landfill space and resources indicators. The overlapping between energy and resources can partially be solved by having a breakdown of the resources indicator into energy carriers and material resources.

A comparison of waste management systems or materials based on the energy indicator is therefore informative, but in order to produce fully valid comparisons, it has to be supplemented with information about the energy sources used and substituted, both upstream and downstream in the life cycle.

An additional idea behind the energy indicator is that it captures the magnitude of the reduction of the use of energy that is achieved by incineration compared to the energy consumption in the life cycle of the material.

Resource indicator

The indicator on resource consumption describes the overall consumption of materials in the life cycle of a waste material weighted in accordance with the relative scarcity of the resource. The indicator is especially meaningful when comparing the amount of resources that is lost when a material is recycled, incinerated, or deposited in a landfill.

The idea behind the indicator is that it brings to light the magnitude of the reduction of the use of materials from virgin sources that is achieved by recycling, i.e. the magnitude of the impacts associated to raw material extraction and refining.

¹ If the Danish LCA methodology 'EDIP' is used, person-equivalents (PE) in resource use (including landfill space) are calculated as the consumption in the scenario divided by the consumption of an average person in the time frame of the scenario's functional unit.

² In EDIP, weighted PE of a given resource (including landfill space) are calculated dividing the normalised PE by the supply horizon of the given reserve and are called person reserves (PR).

Hazardousness indicator

The hazardousness indicator will be discussed here in more detail since it is more controversial than the two other indicators. The goal of creating the hazardousness indicator is to be able to assess where and how prevention actions can help to reduce environmental impacts related to the relative risks or hazardousness of the different waste types or streams, studied in this project.

It was not feasible to assess the toxicity potential of waste streams in the way normally done in LCIA since this would require knowledge of specific amounts of all the relevant substances (e.g., heavy metals, persistent and volatile organic compounds, corrosives, etc.) in the different waste streams – on the European scale! Entering meaningful data into a model, for instance, on the occurrence of different types of toxic heavy metals and their specific or general concentrations and exposure pathways in e.g., treated wood (thousands of different paints and solvents applied in different numbers of coating by different technologies), and in ferric metals or cement, or the occurrence and concentrations of toxic and corrosive substances in household, agro- and industrial chemicals, in the general waste streams, on macroeconomic level, is not yet feasible, unfortunately. As Herczeg et al. (2005) argued, the tracking and analysis of any single substance, on macroeconomic (EU-wide) level, is not realistic and feasible with the current data recording and management procedures in Europe. Since in our case - a European-wide waste prevention study - neither LCA nor risk based approaches are applicable, a general but simple and practical solution had to be found.

There are different approaches regulators take for grasping and managing the hazardousness of waste streams, polluted lands, and other wasted resources. The most wide-spread one is to derive lists of ‘priority chemicals’ or substances that are known to have harmful properties. These lists have been constructed by decades of research in public health and environmental sciences, and have been summarised in e.g., Giegrich et al (1993), AOO (2000), Gendebien et al. (2002), Holm et al (2002), Weidema et al. (2005), US EPA (2006), etc. Table 2.1 below summarises the results of a screening of existing EU waste legislation for regulated substances in, e.g., air emissions, surface water emissions, and emissions to soil and groundwater.

Table 2.1: Results of a screening of existing EU waste legislation for regulated substances in e.g. air emissions, surface water emissions, and emissions to soil and groundwater

Specified			Unspecified
Heavy metals	Organic	Inorganic, semimetals	
Non hazardous Waste legislation			
<u>Air emissions:</u> Cd, Tl, Hg, Cu, Sb, As, Pb, Cr, Co, Cu, Mn, Ni, V, Zn		<u>Air emissions:</u> NO _x (NO, NO ₂) HCl CO HCl HF, fluoride SO ₂ H ⁺ , measured as pH	<u>Air emissions:</u> Total Dust VOC, measured as TOC Dioxins and furans <u>Water emissions:</u> Dioxins and furans Total suspended solids TOC Phenols oil/hydrocarbons
Hazardous waste legislation (Annex)			
All heavy metals and their compounds: Arsenic; Antimony; Barium, compounds excluding barium		The following alkaline or alkaline earth metals: Lithium Sodium Potassium Calcium Magnesium in uncombined form;	inorganic sulphides; inorganic fluorine compounds, excluding calcium fluoride; inorganic cyanides; acidic solutions or acids in solid form; basic solutions or bases in solid form; phosphorus: phosphorus compounds, excluding mineral phosphates; metal carbonyls;

sulphate; Beryllium Boron Cadmium; Chromium (VI) compounds; Cobalt; Copper; Lead Manganese; Mercury; Molybdenum Nickel; Selenium; Silver; Tellurium; Thallium; Tin; Titanium Vanadium Zinc;	Asbestos (dust and fibres);	peroxides; chlorates; perchlorates; azides; PCBs and/or PCTs; pharmaceutical or veterinary compounds; biocides and phyto-pharmaceutical substances (e.g. pesticides, etc.); infectious substances; creosotes; isocyanates; thiocyanates; organic cyanides (e.g. nitriles, etc.); phenols; phenol compounds; halogenated solvents; organic solvents, excluding halogenated solvents; organohalogen compounds, excluding inert polymerized materials aromatic compounds; polycyclic and heterocyclic organic compounds; aliphatic amines; aromatic amines C46 ethers; substances of an explosive character, excluding those listed elsewhere in this Annex; sulphur organic compounds; any congener of polychlorinated dibenzo-furan; any congener of polychlorinated dibenzo-p-dioxin; hydrocarbons and their oxygen; nitrogen and/or sulphur compounds not otherwise taken into account in the annex of the directive.
---	--------------------------------	--

This list contains over 75 entries, but is still much shorter than the over 5000 substances and unspecified compound groups, which might be emitted to the air, soil or water via e.g., wastewater, temporary deposits, or air emissions during production in the industry, addressed by all different kind of EU legislation. These substances are not necessarily linked to waste streams, even though they could be of interest in the context of prevention actions.

Clearly, for the sake of this study, attempting to identify every toxic substance that might end up in various waste streams across Europe, and then assign a *generic concentration* value for each of them, in every such waste stream, would be a futile and unrealistic attempt. What the authors suggest instead is the utilisation of these lists for the characterisation of harming potentials for the priority waste streams studied in this project.

Thus, along with the original concept in this project's implementation plan, the use of qualitative hazardousness indicators seem the appropriate solution, which can be combined with the LCA model generated resource indicators, when aiming at assessing the overall environmental impacts of general waste streams.

Scoring methods

Assigning numbers to the level of risk or harmfulness of wastes, while not simple, can be done. This requires the understanding of the complex processes involved, their categorisation, scoring via expert judgement, and, in case of need for quantification, a bit of arithmetic. There are many different hazardousness ranking methods and models applied throughout the economy, with specific endpoints of analysis (e.g., human health, biodiversity, economic gain, etc.), and none of them can exclude the subjective evaluation of field experts, scoring on various relevant parameters when characterising and assessing complex matrixes of environments, materials, and their properties, let alone their potential effects, and the extent to which they might affect various receptors. Scanning the literature will quickly prevail such assessment models as the priority setting models, the transport models, the exposure models, the ecosystem models, the importance models, and the risk-

and economic-based models. The rapid growth in the availability of these models makes the consensus on the correct assessment and planning of ensuing best actions ever more difficult for the regulators and other stakeholders (Ashford & Miller, 1999; CARACAS, 1998; US EPA, 1998; CENR, 1999). Understanding the detailed scientific bases of the models and the many assumptions underpinning them requires substantial capacities of all stakeholders, most of all, the regulators. Because of this, most countries prefer to focus attention on only a few of these models that have been thoroughly peer reviewed for use within the national and international contexts (McCally, 2002).

With inspiration in the hazardous ranking system (HRS), the principle mechanism US EPA uses to place uncontrolled waste (sites) on the National Priority List we designed a suitable and simpler risk-based scoring system for the hazardousness of wastes. Risk-based rating is the procedure to score substances by the order of their hazard potential, by the order of their monitored or predicted occurrence, and by the order of their probability to establish contact with sensitive receptors – humans and other environmental system components. Later ranking processes can be carried out separately, based on the scoring system, where the ‘relative occurrence’, and the ‘exposure pathways’ are combined with the ‘relative hazard potential’ of the substance. The position of a substance on such a combined rating (and ranking) list may be called ‘relative risk’ or ‘hazardousness’, as we refer to it in this study.

The rating procedure, ideally, should still consider most of the recognised components of the complex waste system, including:

- characterisation of waste – scores given along the existing priority lists plus information on suspected harming potentials and the lack of these, e.g., non-toxic/corrosive/etc.; suspected harm potential; and known harmful substance;
- risk-based concentration(s) and their limit values;
- exposition/dose of the receptors, i.e., extrapolated for the affected people and other living organisms;
- affected populations and media in natural and built environments: air, surface waters and aquifers, soil, food-chain, with the ultimate end of analyses - human health, with specially susceptible or protected populations, including children, elderly, people with compromised health status, low income communities, etc.;
- release and absorption pathways, where pathway scores can be calculated;
- inert or reactive/soluble/volatile, persistency, and ability for bioaccumulation status of the concerned waste, or the containment matrix into which it gets encapsulated (e.g., asphalt, cement, or soil, etc.);
- sensitivity of site and region by e.g., safety of containment, carrying capacity of site, special policy controlled areas like national parks, etc., and/or the sensitivity of the affected population, including the understanding of susceptibilities;
- biodegradability and natural attenuation of waste or substance in concern of release;
- consideration of the used waste management mode and their inherent environmental health risks;
- extent/size/volume of waste or substance.

All *exposure models* are variants of the following simplified formula, with typical units shown for soil ingestion as an illustration:

$$E = A \times T \times R \times C / B$$

where E is exposure or absorbed dose (mg per kg body weight per day), A is soil intake rate (e.g., soil per day in grams), T is time of exposure (days), R is resorption rate (per day), C is concentration of contaminant in the uptake medium (mg per gram of soil), and B is body weight (kg).

A simplification of the method was performed selecting the type of analyses and information that provided most useful information for our purpose, and could be realistically managed in the frame of this project. We had data on the quantities of major waste streams in European countries, which provided input into occurrence. We have checked the existing priority chemical lists for scoring harming potentials, extended with our expert knowledge on chemicals' safety. We utilised some of the knowledge gathered via relevant studies, e.g., on the typical receptor or media that get affected by various substances, which was very useful for assessing exposure paths. The simple ideal equation we could use for our purpose was:

$$\text{Hazardousness (Relative risk)} = \text{Harming potential} \times \text{Occurrence} \times \text{Sensitivity} \times \text{Exposure}$$

Scoring tables (see Table 2.2.) were drafted for the quick and easy use of experts to score each of the main waste streams we have collected information on.

Table 2.2: Hazardousness score tables

Harming potential score				
Toxicity	Corrosiveness	Flammability	Reactiveness	Total

Occurrence score			
Quantity	Spatial distribution	Waste management mode	Total

Sensitivity score		
Sensitivity of site and region	Affected media and population	Total

Exposure score				
Pathway analysis	Inert or reactive/soluble	Time horizon	Concentration	Total

The total scores on each assessed aspect of hazardousness were assessed, providing the overall hazardousness scores of *low*, *medium* or *high*. The depth of concrete information did not allow for using a more detailed scale (e.g., from 1 to 100 or even from 1 to 10) thus the rates assigned had to be limited. Please, note that these are relative scores, indicating the level of hazardousness of the studied waste streams, basically compared to each other, not anchored to a specific threshold or limit value. This hazardousness indicator is a qualitative indicator, understanding the non-feasibility of ordering specific numbers or powers to each waste stream, due to the complexity of that approach, and the lack of specific information on waste streams to support it. Nevertheless, this method is thought to be suitable for the purpose of selecting the waste streams, relative to each other, with highest environmental impact saving potentials, related to their hazardousness.

The strengths and weaknesses of the three chosen indicators are discussed in the following.

2.1.2.4 Strengths and weaknesses of the indicators used

In the following, a discussion of the strengths and weaknesses of the use of the three indicators is carried out. How do they fulfil the goal of the environmental assessment? Are there any barriers in their calculation? Are there barriers in their interpretation and use?

Resource indicator

Strengths: The life-cycle mass balance of resource use is a very powerful proxy of the physical investment made in a material through its lifetime. All materials' production, consumption and disposal have a backpack of materials.

This information is useful to give an order of magnitude on the impacts of the material, and together with information on where the resources are used, it helps understanding the flows and the impacts caused by a material. However, this is all that the indicator can provide, unless specific information on the quality of the resources is supplied. A distinction between energy resources and other resources has been made. This has provided some additional insights, and has made possible to see the contribution of energy to the life cycle of materials.

Weaknesses: The scarcity-based weighting of the different non-renewable resources is based on their supply horizon which depends on other aspects than the scarcity and can hence only be seen as a proxy of the scarcity. In addition, the renewable resources tend to fall out of the resource indicator which thus mainly focuses on the use of non-renewable (mineral) resources.

Primary energy indicator

Strengths: The life-cycle energy balance of a material is also a very powerful proxy of the investment made in a material through its lifetime. All materials' production, consumption and disposal consume some energy. A readily available material, like sand, will probably require little energy for extraction and treatment, and due to its availability, not much will be lost if it is landfilled. A metal like aluminium requires large amounts of energy being put in its extraction and refinement, manufacture, and this embedded energy is lost if it is landfilled. In addition, other metals like lead are directly or indirectly toxic through e.g. air emissions and require supplementary energy for treatment in a system where such toxic effects are known. Energy indicators, if well calculated and in regions with developed waste treatment systems, are therefore a very valuable indicator of the environmental value/load of a material.

Weaknesses: The problem – a general problem of all indicators – is the inability to capture all direct and indirect energy inputs to the material.

If energy is generated from fossil fuels, the energy indicator is connected to air emissions (CO₂, CO, NO_x, SO₂) that are known to give rise to a series of impacts such as acidification, nutrient enrichment, photo smog, and climate change. If all flows are captured, the indicator is highly informative, but if the characterisation of the energy system is faulty, for instance if the energy used for end-of-life treatment of aluminium and lead is not included, a comparison of the environmental load of these two metals is not useful.

The total energy is, in some cases, not enough for strategic planning: as discussed in the results section regarding the comparison of lightweight packaging incineration and recycling, both options contribute to a similar energy saving, but in one case the energy source is oil, and in the other it is coal. Which one to choose, may depend on other strategic and non-environmental considerations.

Hazardousness indicator

Strengths: The hazardousness indicator provides an insight into those physical and chemical properties of materials and/or waste flows that can pose risks to human health and to other environmental system components. While the material and energy resource indicators inform about the quantities or intensities of resources used, the hazardousness indicator adds much needed information on the qualities of the studied (waste) resources.

For the purpose of selecting primary material/waste flows for prevention, a relatively simple, life cycle based *comparative* analysis is enough to score and rank the flows for their hazardousness, requiring no sophisticated modelling. Regardless of the limitations mentioned below, this indicator is still providing direct connection to the potential environmental impacts of material and energy intensities.

Weaknesses: Analysing hazardousness for generic waste flows - on macroeconomic level -, naturally, involves several limitations. In this study the focus has been on toxicity, while the hazard potential of materials depends also on corrosiveness, flammability and reactivity. When looking into occurrence, quantities and waste management modes have been considered, but spatial distribution was not possible to assess, since there are tens of thousands of waste sites across Europe, many of them in non-standardized fashion, and without being well recorded in international

databanks. Similarly, the sensitivity of sites and regions, and the affected media and population could not be assessed. In the exposure analysis, inertness, time horizon and relative concentration could be considered, with minor attempt to scrutinize the potential exposure paths.

2.2 Policy analysis framework – patterns, regimes

The procedure applied in the evaluation of effectiveness of policy actions especially in chapter 6 will be described (and made operational) in this section, resulting in a procedural framework for analysing common types of changes and the related policy regimes and policy patterns and qualitatively assessing the waste prevention in terms of the possible impact on waste flows. The analysis guidelines will not produce policy indicators but primarily serve to illustrate what aspects should be considered when developing waste prevention policy and describe characteristics on how different types of policies affect innovation and the resulting waste streams. The aim of the analysis guideline will also be to analyse how the dynamics of innovation can be affected by various approaches to waste policy and what change in the environmental balance of waste management would result in the light of potential innovation.

The outset for this project is the definition of waste prevention given by OECD and taken up by the EU as the basis for the unions' waste policies (OECD 2000; EC 2005a). The basic definition operates with a fundamental distinction between products (functionally useable commodities) and waste (things having entered the waste and not any longer for intended use). Seen in relation to innovations in companies, the definitions of waste prevention are quite negative. Waste prevention takes place (long) before products and materials are identified in the waste stream and only in cases of re-design the factual knowledge from the waste streams can be accommodated in the design phase. An environmental or health problem must have been identified and an existing waste stream must have been targeted to come to these relative changes that are then identified as waste prevention. Otherwise the focus must be on environmental awareness and eco-design, or what could be phrased as good engineering practice and design work using LCA methodologies. In this case these efforts do not present themselves as waste prevention but as conventional practices for materials use, products, and processes. A different situation is apparent on e.g. recycling of packaging materials and other products that function as utilities and not as end products for use.

2.2.1 Problems of policy analysis – impacts and effectiveness

One of the fundamental questions raised in the project is the impact of waste prevention policies on innovation and in a broader sense the interrelations between innovation and waste creation and how especially waste policies influence this relationship, but also how waste policies might cross act with other fields of policy that directly or indirectly impacts the creation of and hazardousness of waste and the types of innovations that influencing this.

Maybe one of the most challenging problems in policy analysis is the difficulty in singling out policy interventions and evaluating their impact. The rhetoric of policy processes and the identification of chosen policy measures and even the construction of instruments to be used in policy implementation are rather easy to identify and follow as they most often are explicit in statements, reports and rules. In contrast the implementation and the impacts of policy interventions are more difficult to study. Not least because specific policy interventions most often do not stand alone, but are influenced by on one hand the policy discourse itself and the views and intentions expressed herein, on the other hand by other policy instruments with different objectives. Overlapping policies coming from different fields of policy with very different objectives or even counter measures set in motion by involved actors might be as powerful as the policy action studied. In a business setting this will include the perspectives assigned by management to certain anticipated market and technology developments framing the types of strategic priorities of companies and the types of innovations focussed upon.

The prevention of waste constitute a part of the overall environmental protection policies, at the same time, as waste handling in most countries – though in very different institutional forms and with different boundaries for the public responsibilities – have been taken care of by public institutions. This has historically given way for a conflict between environmental policies concerning commercial activities and the regulation of waste handling activities. And it is first in recent years that regulatory demands are becoming increasingly similar also in practical terms of enforcement targeting the waste handling sector with similar requirements than industry.

2.2.2 Theoretical considerations

The analysis of impacts of certain policy actions would ideally have to focus upon the objectives or intentions expressed in the process of creating the policy action, though already here we are facing certain problems as policy formation processes can serve a multitude of purposes – and they often do. While many of the studies of policy are requested by the policy making institutions and ideally include the implementation and working of the policy in scope of research, the role of the results of this types of research is more complicated as it often ends up as selective arguments in specific actors' positioning in the policy discourse.

In the model for policy evaluation called DPSIR the idea is to build a rational, closed loop representing all aspects of material oriented policy processes based on the parts: 'Driving forces', 'Pressures', 'State', 'Impacts', and 'Responses' (EEA 2001). Some of the elements are rather easily measured as part of the creation of measurable environmental objects in the core phases focussing on pressures, state, and impacts, while other parts are projections of this constructed reality on very different domains of knowledge and societal processes. The driving forces are therefore often loosely identified and rather general in their character as are the idea of measurable responses in the form of policies, management procedures, or knowledge and design processes. Nevertheless are quite large efforts made to produce such measurable categories, and as is the case in series of reports from OECD and the Commissions reports and own institutions (OECD 2004; EEA 2001), a lot of effort is put into filling this gap – without questioning whether this mission is a policy demand having lost a realistic picture of the complexities involved in the social processes. Instead of taken studies of politics serious, driving forces and responses are anticipating to be treated in the same way as the core measures of the environmental data. For this reason a different approach is taken in this study.

Analysing impacts of policies opens for a range of questions covering the complete intended and factual policy program that is initiated. It includes studying the scope or objective of the policy, the choice of measures and instruments, the implementation of these instruments in the daily regulatory practices of responses and enforcement, eventual counter measures from the side of regulated actors also identified as counter programs, the impact of the policy which often entails a problem of identifying a baseline for comparison and the eventual synergies between both mutually supporting policy programs and conflicts among others.

2.2.2.1 Effectiveness of policies and the role of indicators

In this project the notion of effectiveness is used to discuss the results of established policy patterns in reaching articulated objectives for the policies in question. While the use of indicators is not in general seen a realistic and feasible way to identify the effectiveness of policy patterns and regimes, it is relevant to discuss how effectiveness can be understood in a more qualitative manner and in which (special) situations indicators may be used in more quantitative studies.

The European Environment Agency has defined the notions of effect, effectiveness and (even) cost-effectiveness as follows (EEA 2001, 9) where the notion measure equals the use of instrument in this report:

-
- Effect of an environmental measure: the results of a measure that can be directly attributed to its implementation. This requires that a causal link exists between the policy action and its intended impacts on human behaviour and the environment.
 - Effectiveness of a measure: a judgement about whether or not the expected objectives and targets of the policy measure have been achieved. This requires comparing the effects of the measure with its intended objectives.
 - Cost-effectiveness of a measure: a comparison of the effects of a set of measures with the costs of implementing them. A more cost-effective measure will have achieved greater results for less money.

There are in these definition an implicit tendency to favour measures (instruments) and objectives that can be stated in quantitative or at least measurable terms, which follows the ideas embedded in the DPSIR-model introduced and commented upon in section 2.3.2. While the environmental aspects and processes in the model follows the causal principle already from the basic definition of the environmental objects in question, the responses are not causal and impact all other elements of the model (EEA 2001, 21) and are difficult to capture with the anticipated factorisation principles employed in the DPSIR toolbox (ibid, 23).

Existing examples of successful use of quantitative measures of impacts and causally linked policy measures are found especially in cases where single substances are in focus and where the sources of pollution and responsible agents can be identified. This is the case for e.g. lead (the introduction of e.g. un-leaded petrol), nickel (banned in e.g. Denmark from consumer product), SO₂ and NO_x, (resulting from heaters and combustion processes, though policies have been slowly developing), and ozone depletion (the banning of CFC and other gasses). These are also the examples used in most discussions of quantitative oriented effectiveness, but it must be kept in mind that these cases more likely are to be seen as special instead of viewing them as the illustration of a more generally applicable method to document effectiveness. In several of these cases also studies of cost-effectiveness are possible as the costs avoided in most of the cases are rather high and giving legitimacy to the environmental policy efforts in question.

But the quantitative approach becomes potentially misleading when it comes to more diverse goals with distributed sources and responsible agents and a need for using a multiplicity of policy instruments as argued in the previous section on policy patterns. In these cases there is a need for a more qualitative approach still aiming at identifying the impacts of policies at large, and still discriminating between different policy strategies and coherent versus divergent policy patterns. Such qualitative measures are dependent on the detailed reporting of the policies in question and the intended objectives where the presented line of argument becomes a main part of the documentation of the effectiveness. The assessment of effectiveness will include the legitimacy of both the policy objectives in question and the outcomes and impacts of the process at large. Also in the cases where counter-programs are introduced and the relevance of the environmental objectives themselves are questioned these will be included in the assessment of effectiveness e.g. raising doubts about the objectives and the legitimacy of the policy at large and weakening the consensus about the framing of the actual policy process. These aspects of the effectiveness cannot be left out, but must be a part of the qualitative assessment.

Hypothetically indicators for the impact of innovation on resource consumption and waste prevention may be developed based on the idea of factor reductions in the consumption of virgin resources and the avoidance of using hazardous substances ending up in the waste streams. Many innovations are already focussing on such reductions as the minimization of costs of materials is part of a standard engineering design practice, but this approach does neither take into account the growth in consumption nor the qualitative outputs of products in use. While it is obvious that computers are getting lighter and more powerful it is less obvious which tasks they fulfil and how the growth in numbers and pervasive character of computing does affect effectiveness.

Such measures of reductions in virgin resource consumption and hazardousness will demonstrate the aggregate impacts of a multitude of company strategies, market developments, policy measures, and innovations of which some may be the outcome of the former, while others may have other origins. In short: indicators for waste prevention may be constructed and turn out useful, but the construction of causal relations satisfying the standard assumptions of policy effectiveness will in the same move become even more difficult to create.

2.2.2.2 Empirical versus model based studies of policy impacts

The complexity involved in producing a solid empirical foundation for analysing the impacts of policy and policy instruments is also related to the translation of policy objectives into specific policy measures by the choice of instruments (implementation mechanisms) and the institutions used in the implementation (the framing of instruments). The choice of instruments is not only based on a specific analysis and insights into the field of actors and their behaviours constituting the legal objects of regulation, but also some more general policy styles developed in already established government and other involved institutions attempting to replicate known practices and measures. At the same time the complexity of implementation often leads to the construction of theoretically founded policy instrument rationales using stylised arguments and simplified models of actors' responses and behaviour. Besides the problem of institutional patterns demonstrating conservatism and replication, the use of stylised arguments for specific types of instruments also support a context of implementation that does not relate to the regulatory objects and problems in question but to some temporary policy preferences and styles.

Examples of such model based and stylised arguments for the specific qualities and working of instruments is found in the field of economic instruments where environmental charges and other measures are seen as ways of internalising environmental costs and thereby changing the preferences and choices of companies and other actors. Another type of instrument is to create markets for certain limited capacities of nature and let the restricted availability of e.g. CO₂ emissions become an object of trade defining a price, that again somehow internalises the 'costs' of a formerly free, but environmentally limited resource or capacity. The standard arguments for these types of regulation are build on economic models of market competition and assumes that economic actors – companies – will respond rational to the new costs, which provides these regulatory instruments with the label of being market conform and in favour of innovative solutions. The problem from practical implementations, though, show that it is not the internalisation of costs per se that transform companies response, but the availability and risks associated with alternative actions and technologies that defines the agenda for change (Jørgensen 2005). Whether these mechanisms have an impact or not can therefore not be based alone on in a disciplinary framework of economic theory nor in the rather general policy based framing of the instruments to be market conform.

The last research challenge to be mentioned – but not the least important – is the role of the institutional and regulatory context already in place for the norms and considerations about what is defined as waste stream and which of those including which substances are defined hazardous and therefore targeted in the waste handling procedures. The consequences are very visible in e.g. waste policies using waste charges which result in counter programs where the waste streams are changing based on the responses of companies and other stakeholders getting involved in waste prevention actions not necessarily changing the amounts of waste production and its hazardous components but leading to more reuse and to substitutions between waste handling and transportation of the products for reuse and even export of tradable components. Whether this is an impact to be accounted for as waste prevention may be solved by definitions, but is much more difficult to account for in relation to the kinds of aggregate waste statistics available.

Another aspect of how the waste policy itself influences the characterisation of waste and its hazardousness is the very basic waste policy preferences – which can be emphasised as different policy styles between countries – in the choice between a waste handling based on incineration or on deposits for waste. While deposits produce a widespread problem of long term control of waste deposits especially from gasification processes and hazardous leakages, the incineration process include some of this in a reuse of the energy content, decompose some of the hazardous substances, but at the same time concentrated other hazardous waste elements and even produce new environmental problems by e.g. acidification of the emissions to the air, which then again does lead to waste policies where certain materials (e.g. PVC) produce supplementary environmental problems from the handling of the waste streams.

2.2.2.3 The multiple objectives of policies

In the literature focussing on policy analysis and the study of policy impacts there has been a rather general tendency in the later years to emphasise the role and importance of government in a multitude of functions as a mediator, a provider of negotiation space, and as regulator in the field of environmental protection.

New perspectives on government actions are described and also influenced by the changing views on regulation from viewing government primarily as a central authority to an actor in network based governance. This shift does not imply that government's role is diminishing, though it may change. Studies of environmental policies and protection measures quite clearly indicates this shift, but also that successful environmental improvements in industry are to be found in the cases where government has played a consistent part by setting goals and timelines for improvements, by funding or in other ways supporting innovative changes, by setting taxes providing significant changes in cost structures, or by intervening with traditional legal requirements. In those cases where declared government policies were not followed by other supportive measures or even just the threat of future intervention in case of non-compliance with the policy objectives, not much happened (de Bruijn & Norbert Boehm 2005). This indicates on one side the importance of government intervention and interaction, but it also demonstrate the role of consistent series and generation of policies as opposed to an idea of on single policy should do the work.

2.2.2.4 Policy patterns and implementation context

In the cases where different policy measures are used in combination or impact the same field of actions in society they can be characterised as a 'policy pattern' as described by Jänicke (2000). The concept can be described with three dimensions (see also table 2.3):

1. The structure of the instruments (or programme) in relation to specific environmental goals.
2. The policy style of government institutions on environmental issues.
3. The political-institutional context of the actors and actions

Table 2.3 Policy patterns of environmental policy (reproduced from Jänicke (2000))

Instruments	Policy style	Political-institutional context of action
<ul style="list-style-type: none"> • Dominant instrument in the mix • Degree of determining behaviour • Punctual versus strategic approach 	<ul style="list-style-type: none"> • Form of target setting • Flexibility in applying the instruments • Timing of the measures • Orientation towards consensus • Legislation, bureaucratisation • Calculability 	<ul style="list-style-type: none"> • Competence and the influence of the regulating body(s) • Role of other policies (policy integration!) • Relation between regulators and regulatees • Role of non-governmental environmental institutions

This perspective of policy impact analysis summarized in the term 'policy patterns' shifts the focus from the single measures to the impact of consorted actions of parallel and sequential policies and thereby the context of implementation is also emphasised. This leads to a focus of the dynamics and

synergies of policies contributing to sustained policy interventions emphasising more or less identical perspectives in a multitude of actions, or in contrast to conflicting policy measures and visions leading to either shifts in the direction of the actions of the regulated or lack of impacts due to the lack of clarity and delayed responses. Policy patterns are the sum of all calculable rules, manners of proceeding (practices and routines), and contexts of action within an area that is subject to government control (or intervention). Individual instruments and especially sustained and long term policy objectives followed up by sequential instruments are in this context important but through their consorted impact.

The structure of professionalism in environmental institutions and their ability to enrol actors in supportive networks is also crucial, as is the configuration of actors and whether the policy is inclusive or limits its focus and dialogue to exclusive actors and favours the interests of certain polluters. This is also relevant for the responses from the regulated companies and their context of suppliers and customers including the potential and content of eventual counter programs created to avoid the impact of certain policies.

2.2.2.5 Regulatory regimes and the institutional context

The hegemony of certain well established policy styles like the command and control based legal regulation of environmental permits (whether they are seen as production or pollution permits) based on emissions standards forms what can be phrased as 'regulatory regime'. Such regimes do impact policies more in general, as they form a pattern of institutions and practices easy to reproduce in new areas of policy. This limits the specific possibilities of designing policy measures in accordance with the objectives of these new policies. Instead a pattern of institutional replication can be found, as it can be seen in the EU directive IPPC (Integrated Pollution Prevention and Control) where the impacts of cleaner technology efforts from industry and government are forced into a process of translation from specific documented complex impacts and improvements into (reduced) emissions standards. This transform the focus on front end innovations into a process of negotiations levelling out the potential impacts of radical innovations and improvements to a lowest level of commonly accepted solutions and recommendations.

The role of the institutional framework and the translations resulting from moving from the policy discourses and objectives to the choice of regulatory framework and again to the 'street level' implementation is handled in an analytical framework focusing on the constitution of 'regulatory regimes' (Jørgensen 2005). The focus of the introduced framework is the interdependency of actors, their knowledge, and their interactions in relation to specific forms of environmental regulation. The combination of specified environmental objects and the established practice and knowledge of the institutions responsible for the implementation using specified instruments define the backbone of a regulatory regime. Regulatory bodies and the regulated companies are important in this respect, but also other actors may play certain parts as e.g. customers, suppliers, consultants, and knowledge institutions producing the criteria for regulating the specific environmental objects in question. As does the legal system that typically is involved in the translation of policies into institutional mandates of regulation. Regulatory regimes are seen as integrated systems of social control defining both the potential roles and discourses of the involved groups of actors.

The reason for using regulatory regimes as the approach instead of just policy instruments is to capture the interdependent character of a broad set of aspects related to each of the introduced systems. The coherence and interdependency produces the organisational stability and provides the naturalised arguments against new ideas and practices. The important point being that choosing the method of regulation cannot just be made from case to case as a matter of case-related efficiency and independent of the established institutions and their interactions.

Regulation will most often also refer to a formal set of instruments used to enforce the regulation. These can vary from legal procedures for when and how the regulating body can dictate

requirements to definitions of responsibility or negotiated agreements about the realization of certain action plans. A traditional way of handling legal procedures in environmental protection is to identify a company not complying with given environmental permits, and after having forwarded certain warnings, prosecute the company in court. The type of information that has to be accounted for defines the specific character of the enforcement problem of a regulatory regime. If the regulation is heavily dependent on continuous controls of pollution it is necessary to provide this information to maintain regulation and control. If the control procedure is left to companies by means of self-control systems, enforcement has to shift from control of specific pollutants to the control of process data and organisational procedures. When having defined the environmental problems in question and the needed type of knowledge it is rather obvious that a distinct type of professionals will be needed to maintain the regime. A focus on ecological capacity makes environmental control the activity for primarily chemists and biologists, while a focus on cleaner technologies move production and environmental engineers into the core group of competent professionals.

2.2.2.6 Policies supporting environmental innovations

The formation of innovation policies has been a very conflict ridden area, where different agencies involved in national policy as well as different directorates in the EU have outlined and implemented rather different policy agendas and instruments. An example is the overall policy of the EU which has been divided into two different strategic objectives. One has been focussed on the construction of the inner market and subsequent ideas of limiting national control and support measures for companies in several cases also including policies directed to the control of environmental issues. While other policy has been focussed on supporting strategic research and creating cross border cooperation on developing cleaner technologies and have set common rules for emissions and pollution prevention.

The relation between regulation and industrial innovation spurs controversy also in the literature (see e.g. Hemmelskamp, Rennings & Leone 2000), and there are a number of examples showing that strict regulation focussing on very specific (technical) solutions have produced excess costs (Kemp 1997). This point to the importance of the detailed implementation schemes for environmental regulation and the need for a constructive dialogue between business and regulators. But as the outcome of innovation is not only measured by the impact on single companies and first movers, it is important to measure impact on the overall adoption of cleaner technologies. Also the fact that the innovator may be in the supply chain of the polluting company demands a deliberate policy to support the creation of markets for cleaner technology by either building competences with the users of that technology or creating networks involving the suppliers in the process of change (Andersen & Jørgensen 1997; Kemp 1997).

Three levels of policy interventions are obvious in the field of innovation policies, and each of these can be linked to and even coordinated with environmental policy and as in this case waste policy measures. These are: guiding research, supporting new innovations, and controlling the impacts of already established technologies and practices (DEPA 2006).

The first is the importance of guiding research to include environmental perspectives, including policy options for assessing research strategies and potential outcomes, creating visions and objectives for areas of research, and setting the stage for prioritising the research to be supported by government and private funds. An important question here to be addressed in future research policy is when and how to carry out dialogues and other policy measures in relation to research in order to obtain an enhanced focus on environmental potentials and risks.

The second area of innovation policy does focus on innovative activities on the combination of technologies within specific fields of application creates the core elements of strategic innovation policies. The results of such policies should be the creation of new paths for technological

development by supporting the critical and highly uncertain first steps of bringing good ideas with potential environmental benefits from the laboratory and sketch board to real prototypes and scale tests. This kind of strategic innovation policy may also include a market support structure based on an open and competitive definition of the technologies and application to be supported combined with regulation of potential application fields, support for demonstration projects and network activities involving potential suppliers, customers, knowledge institutions and intermediaries.

The third field on innovation policies does link more closely also to at least some parts of environmental and waste policies. It is concerned with regulating technology applications through the regulation of driving forces and institutional frames determining the use of products, the development of consumption areas etc. Here a number of different policy instruments will become relevant and the coordination of policies between the domains of policy in focus. This type of policy integration is taken up in the IPP (Integrated Product Policy) and typical instruments will include a variety of known interventions like the banning of certain substances and the creation of industry responsibility for specific design measures and take-back options.

Technology applications within environmentally important product and consumption areas could be influenced in a more environmentally friendly direction by identifying and regulating the impact of driving forces and the institutional regimes determining the use of materials, production processes, products etc. If mature and market introduced technology applications with 'green' potentials are not realised under present market, production, and user regimes more stringent regulatory policies and standards could provide a difference. A sector or product domain approach may be needed in stead of a technology approach as it is envisaged in the contemporary European regulation of electronics products.

2.2.2.7 Potential economic benefits of waste prevention

In this project the aim concerning economic evaluations of policy actions and alternatives have been limited to qualitative description of the economic benefits associated with implementing waste prevention plans and actions in those cases where data were available. The literature on the economic management of waste is quite sparse; nevertheless, there are some relevant publications pertaining to the economics of waste management that can be consulted, including OECD's *Addressing the Economics of Waste* (2004), ECOTEC's (2001) *Beyond the Bin: Economics of Waste Management Options*, Eunomia's (2002) *Cost for Municipal Waste Management in the EU*, and a Pearce & Brisson (1995) article, *The Economics of Waste Management*, published in the *Issues in Environmental Science and Technology*. Recently, the approach of Environmental Management Accounting (EMA) has been promoted by UNDSO (see e.g. and by a number of national environmental protection agencies as a tool or approach for industry to assess the economic aspects of environmental management, including the costs of waste generation and the thereby the costs of **not** preventing waste generation.

UNDSO (2001) mentions these application fields for the use of EMA data:

- Assessment of annual environmental costs/expenditure
- Product pricing.
- Budgeting
- Investment appraisal, calculating investment options
- Calculating costs, savings and benefits of environmental projects
- Design and implementation of environmental management systems
- Setting quantified performance targets
- Cleaner production, pollution prevention, supply chain management and design for environment projects
- External disclosure of environmental expenditures, investments and liabilities
- External environmental or sustainability reporting
- Other reporting of environmental data to statistical agencies and local governments.

However, this approach is primarily an approach to industry and not presenting calculations about waste prevention. Specific studies directed to the methodology of societal and private economic analyses of waste prevention have not been found.

The real costs of wastes are uncertain, because of the paucity of data for many countries, and in fact, of some relevant data, e.g., on the various externalities, in every country. However, there are different estimates and arguments on the substantial financial burdens waste (mis)management represents to many countries, and especially to poorer communities (Pierce & Turner, 1994). Naturally, the costs of waste management, of related environmental and public health risks, and of other externalities, regardless of the level of sophistication in respective economic analysis, would justify a strong focus on the economics of waste prevention.

A detailed economic analysis would require detailed primary data collection not only for the waste streams at technological and industrial level, but also for the different cost types: direct, indirect and external costs may vary from country to country, and can show substantial regional differences. Estimating the real costs of waste prevention measures is also rather difficult. These actions are usually part of a new technological development, where waste prevention is just one of multiple factors, therefore the share of environmental investments vs. investments, e.g., in improved production efficiency, cannot be proven.

An assessment should consider the exact amount of waste prevented, which is also a very difficult issue. One can measure the waste recycled for example, but estimating the amount of waste that was not generated is a much more complex exercise, and would require several assumptions, e.g., to describe changes in consumer demands, customs, trends, etc.

The external costs of proper waste management itself are gradually decreasing, due to the progressive environmental legislation. However, the external costs of preventable waste streams cannot be considered negligible. The external costs of material resource extraction (e.g., mining) is still high, therefore the external life cycle cost is still remarkable. For example, the external costs of waste production and the value of losses in environmental resources ('tragedy of common goods') are not well recorded in international databases, neither are the maintenance costs of waste facilities, or the production costs of the many different materials.

This result in the following cost components which would need to be included in economic assessments of the economic aspects of waste prevention, which underpins the difficulties mentioned. Therefore the project has limited its economic evaluation to present cost considerations only when available in existing studies as e.g. part of life-cycle assessments.

Tabel 2.4: cost components

<u>Indicators on direct life cycle costs</u>		<u>Externalities</u>
Production costs	Waste management costs	External costs
<ul style="list-style-type: none"> • Extraction of virgin materials • Processing of raw materials • Transportation and logistics (in extraction and production phase) • Direct costs of production (machinery, 	<ul style="list-style-type: none"> • Waste collection • Waste transportation and logistics • Land filling • Incineration • Recycling 	<ul style="list-style-type: none"> • External social costs • Costs of environmental resources and losses

The authors have consequently aimed at a qualitative description of the economic costs and benefits associated with implementing waste prevention plans and action for authorities, consumers and industry since it is too narrow alone to focus on costs. However it was found that a simple economic evaluation would not contribute much to the understanding of the consequences of different actions primarily due to the high uncertainties and largely qualitative data found. Therefore, a systematic economic evaluation has been omitted from this report and only economic considerations found in the literature about waste prevention and waste prevention policies have been analysed.

2.2.3 Policy options, instruments and types of innovation

The following list gives an overview of the policy instruments that can be identified related to the field of waste prevention and policies oriented towards environmental innovation as these are the types of policy to be discussed. The list is not supposed to be complete, but will be used in chapter 5 and 6 when policies are classified for analytical purposes whether they are analysed as single policies, elements of policy patterns, or related to innovations. The list is grouped into the primary role the policy instrument is playing in relation to materials usage and design, product qualities, and waste streams. It must be noted as also emphasised earlier that the spectrum of policy measures does comprise a large number normally not thought about as waste prevention policies due to the focus on waste prevention resulting from activities in phases of products life-cycle long before these products are recognised as waste and their specific impacts are showing.

Policies directed towards materials use and design:

- charges/taxes on virgin resources and raw materials
- charges/taxes for energy use
- bans on materials or substances used
- announced future policies for phasing out undesirable materials or substances
- announced objectives and priorities for future environmental policies

Policies directed towards product quality:

- design prescriptions (eco-design, labels related specifications)
- classification of (chemical) substances and demands for labelling
- producer responsibility legally defined (can result in charges or take back)
- support and grants for cleaner products and process technologies
- support and grants for research in cleaner materials and technologies
- knowledge support programs for CT like BAT / BREF supporting the IPPC-framework (EU 1996)
- support for research and innovation (e.g. including environmental demands)
- creation of test and up-scaling facilities for complex technologies
- environmental product declaration schemes
- energy labelling and other forms of mandatory labelling schemes
- incentives for companies use of environmental management systems including demands to suppliers
- voluntary labelling schemes
- information support and campaigns towards producers or consumers
- prescriptions for (public) procurements and green purchasing

Policies directed towards the resulting waste stream:

- charges/taxes for by-product or waste streams from production

-
- charges/taxes on packaging materials
 - mandatory waste handling and management procedures
 - conditions for environmental licence to operate (like IPPC)
 - voluntary agreements with government recognition
 - charges and taxes on specific waste streams

Other policy instruments may impact design and waste generation as well though not directly targeting these. They include environmental management systems (EMAS, ISO 14000) setting the stage for e.g. companies design and production activities and environmental licence schemes (IPPC, BAT/BREF) framing the conditions for environmental permits.

This classification of policies takes as the specific outset their relation to waste prevention and environmental innovations having impacts on wastes, while often used and more conventional classification of policy instruments will sort them into e.g. legal, economic, and informative instruments or other types of classifications. In such classifications the focus is on the institutional setting and regulatory regimes framing the policy instruments, which is less relevant when the focus is on the impacts on product innovations and waste creation. Instead our focus in the above list supports the distinction between prophylactic and mitigation strategies. The point being that policy instruments influence different phases of the products life-cycles pointing to and making a comparison with types of innovation possible, as listed in the following.

Innovations related to products and their design:

- product substitution
- material substitution
- added substance substitution
- eco-design based on minimisation of materials and energy used
- eco-design for easy recycling, optimisation for disassembly
- eco-design based on reforming product-service relations
- prolonged life-time of products
- sharing or leasing of goods based on e.g. new service concepts
- new ways of providing services based on dematerialisation

Innovations related to waste handling:

- re-use or repair options
- efficiency in packaging
- disassembly strategies for partial reuse
- decomposition of materials
- incineration to regain energy
- improved environmental protection of deposits including energy recovery

In this perspective the term innovation does include technology, product design, production processes, organisational issues as well as services and sales / ownership structures often also recognised as social and market innovations. The relevance on this broader perspective on innovation is supported by the recognition of the role of the distribution, marketing, and repair of products and even their transformation into more complex structures of product distribution, ownership, and services necessary to reach some of the goals of waste prevention and the reduction in the use virgin resources and energy.

2.3 References

Andersen, L. K. & Nikolajsen, M. H. (2003). Life cycle assessment of chemicals at Brødrene Hartmann A/S, Department of Manufacturing Engineering and Management, Technical University of Denmark, IPL-048-03

Andersen, Michael Skov & Jørgensen, Ulrik (1997). Evaluation of the Cleaner Technology Programme 1987-1992: Results, diffusion and future activities. Environmental Review No. 14. Copenhagen, Danish Environmental Protection Agency. Danish version published in 1995

Anderson, D. et al (2001). Innovation and the Environment: Challenges & Policy Options for the UK. Imperial College, ESCR and Fabian Society.

Ashford, N.A and Miller, C.S. (1991). Chemical Exposures – Low Levels and High Stakes. Van Nostrand Reinhold, New York, NY

CARACAS (1998). Risk Assessment for Contaminated Sites in Europe - Scientific Basis. Vol. 1. LQM Press, Nottingham, UK

CENR/5-99/001 (1999). Ecological Risk Assessment in the Federal Government. Committee on Environment and Natural Resources of the National Science and Technology Council, Executive Office of the President, Office of Science and Technology Policy, Washington D.C.

Dall, O., Christensen, C.L., Hansen, E., Christensen, E.H. (2003a). Resource savings by waste treatment in Denmark. Environmental Project no. 804. Danish Environmental Protection Agency. (In Danish)

Dall, Ole, Carsten Lassen, & Erik Hansen (2003b) Waste Indicators Danish Environmental Protection Agency, Environmental Project number 809

de Bruijn, Theo & Norbert Boehm, Vicky eds (2005). Industrial Transformation: Environmental Policy Innovation in the United States and Europe, Boston: MIT Press

DEPA (2006) Green Technology Foresight about environmentally friendly products and materials - the challenges from nanotechnology, biotechnology and ICT. Danish Environmental Protection Agency, Environmental project – in press

EC (2005a) COM(2005) 666 final. Communication from the commission to the council, the European parliament, the European economic and social committee and the committee of the regions. Taking sustainable use of resources forward: a thematic strategy on the prevention and recycling of waste

ECOTEC's (2001) Beyond the Bin: Economics of Waste Management Options. A final report to Friends of the Earth, UK Waste, and Waste Watch. London, UK.

Eunomia Research & Consulting (2002) Cost for Municipal Waste Management in the EU. Final report to DG Environment, on behalf of ECOTEC. Brussels, Belgium.

EEA (2001) Reporting on environmental measures: Are we being effective? European Environment Agency, Copenhagen

EU (1996) Directive 96/61/EC concerning integrated pollution prevention and control (the IPPC Directive)

EC (2005b) Commission Staff Working Document: Annex to the communication from the commission to the council, the European parliament, the european economic and social Committee and the committee of the regions. Thematic Strategy on the sustainable use of natural resources, Impact Assessment. COM (2005) 670 final Brussels, 21.12.2005 SEC(2005) 1683

Frischknecht, R., Bollens, U., Bosshart, S., Ciot, M., Ciseri, L., Doka, G., Dones, R., & et al. (1996). Ökoinventare von Energiesystemen. Grundlagen für den ökologischen Vergleich von Energiesystemen und den Einbezug von Energiesystemen in Ökobilanzen für die Schweiz, Gruppe Energie - Stoffe - Umwelt (ESU), Eidgenössische Technische Hochschule Zürich und Sektion Ganzheitliche Systemanalysen, Paul Scherrer Institut Villingen/Würenlingen, Switzerland

Geisler, Georg, Thomas B.Hofstetter, & Konrad Hungerbühler (2004). 'Production of Fine and Speciality Chemicals: Procedure for the Estimation of LCIs', International Journal of LCA, vol. 9, no. 2, pp. 101-113

Guinée, Jeroen B., Marieke Gorrée, Reinout Heijungs, Gjalt Huppes, René Kleijn, Arjan de Koning, Laurant van Oers, Anneke Wegener Sleeswijk, Sangwon Suh, Helias A.Udo de Haes, Hans de Bruijn, Robbert van Duin, & Mark A.J.Huijbregts (2001). Life cycle assessment An operational guide to the ISO standards, Ministry of Housing, Spatial Planning and the Environment (VROM) and Centre of Environmental Science - Leiden University (CML)

Harjula, H, et al. (2004): Towards Waste Prevention Performance Indicators. ENV/EPOC/WGWPR/SE(2004)1/FINAL, OECD

Hauschild, Michael & Henrik Wenzel (1998). Environmental assessment of products. Vol 2: Kluwer Academic Publishers, Massachusetts/Springer Verlag, ISBN 0412 80810 2

Hemmelskamp, Jens; Rennings, Klaus & Leone, Fabio eds (2000). Innovation-oriented Environmental Regulation - Theoretical Approaches and Empirical Analysis. Heidelberg, Physica Verlag

Herczeg, M., Carlsen, R., and Nemeskeri, R.L. (2005). Feasibility assessment of using the Substance Flow Analysis method for chemical information on macro-level. ETC/RWM discussion paper commissioned by the EEA, Copenhagen, DK

ISO (2000). ISO series 14040 to 14049 on Environmental management & Life cycle assessment. International Standardisation Organisation, Geneva, Switzerland www.iso.org

Jänicke, Martin (2000). Environmental innovations from the standpoint of policy analysis: from an instrumental to a strategic approach in environmental policy, In Andersen, Mikael Skou & Sprenger, Ralf-Ulrich: Market-based Instruments for Environmental Management. Cheltenham: Edward Elgar

Jørgensen, Ulrik (2005). Cleaner Technology in Denmark - support measures and regulatory efforts. Chapter 7 in Theo de Bruijn & Vicky Norbert Boehm eds, Industrial Transformation: Environmental Policy Innovation in the United States and Europe, Boston: MIT Press

Kemp, Rene (1997). Environmental Policy and Technical Change - A Comparison of the Technological Impact of Policy Instruments. Cheltenham, Edward Elgar

McCally, M. (ed.) (2002). *Life Support, The Environment and Human Health*. The MIT Press, Cambridge, Massachusetts

New Zealand Ministry for the environment (2000). *Environmental Performance Indicators: Confirmed indicators for waste, hazardous waste and contaminated sites*, Ministry for the Environment PO Box 10-362, Wellington, New Zealand

OECD (2000). *Strategic waste prevention. OECD reference manual*, ENV/EPOC/PPC(2000)5/FINAL. Paris, 2000

OECD (2004) *Towards Waste Prevention Performance Indicators*, Working Group on Waste Prevention and Recycling. Environment Directorate.

Pearce, D.W. and Brisson, I. (1995) *The economics of waste management*. In the *Issues in Environmental Science and Technology* (3). Ed. Hester, R.E. and Harrison, R.M. The Royal Society of Chemistry. Cambridge, UK.

Pierce, D.W. and Turner, R.K. (1994) *Economics and solid waste management in the developing world*. Paper at the U of Birmingham Conference – *Whose Environment? New Directions in Solid Waste Management*. Birmingham, UK.

Poll, Christian, Karl Vogt-Nielsen, Frieder Rubik, Michael Søgaaard Jørgensen, & Mette Lise Jensen (2005). *Development of Indicators for an Integrated Product Policy*, European Commission, Study Contract No. 07010401/2004/380896/ETU/G4

Schmidt, A. & Stromberg, K. (2006). *LCA og Genanvendelse*, Danish Environmental Protection Agency, Danish Ministry of Environment, Draft report

Stranddorf, HK, Hoffmann, L., Schmidt, A (2003). *LCA technical report: Impact categories, normalisation and weighting in LCA. Update on selected EDIP97-data*. http://www.lca-center.dk/lca-center_docs/showdocformacro.asp?token=9&id=041104075344&type=doc&fname=EHN_Microsoft+Word++Delprojekt+4+-+Technical+report++nmVOC2_22.pdf

UN. <http://www.un.org/esa/sustdev/natlinfo/indicators/isd.htm>.
<http://www.un.org/esa/sustdev/natlinfo/indicators/isd.htm> . 2006. United Nations. 20-2-2006

UNSD (2001) *The Expert Working Group on Improving the Role of Government in the Promotion of Environmental Management Accounting: Procedures and Principles*. United Nations Division for Sustainable Development, United Nations, New York

UNEP – United Nations Environmental Programme (2003). *Evaluation of environmental impacts in life cycle assessment*. Meeting report. Borghetto Lodigiano, Italy. ISBN: 92-807-2144-5

UNEP(2006) <http://www.uneptie.org/pc/sustain/lcinitiative/>.

US EPA (1998). *Guidelines for Ecological Risk Assessment*. Risk Assessment Forum, US EPA, Washington D.C.

van der Voet, Ester, Laurant van Oers, Stephan Moll, Helmut Schütz, Stefan Bringezu, Sander de Bruyn, Maartje Sevenster, & Geert Warringa (2005). *Policy Review on Decoupling: Development of indicators to assess decoupling of economic development and environmental pressure in the EU-25 and AC-3 countries*, European Commission

Villanueva, Alejandro, Marko Vrgoc, Ole Dall, Regine Vogt, Horst Fehrenbach, & Jürgen Giegrich (2006). Pilot study: Prioritisation of waste materials and their treatment based on environmental impacts, European Environment Agency. Project manager: Bartosz Zambrzycki

Weidema, B. P. (2003). Market information in Life Cycle Assessment, Danish Environmental Protection Agency, Danish Ministry of Environment, Environmental project No. 863

Wenzel H, Hauschild M, and Leo Alting. (2000): Environmental Assessment of Products. Kluwer Academic Publishers, Massachusetts/Springer Verlag, ISBN 0 412 80800 5

Wenzel, Henrik, Niki Bey, Ole Willum, Alejandro Villanueva, & Marko Vrgoc (2006). Environmental benefits of recycling. An international review of life cycle comparisons for key materials in the UK recycling sector, Waste & Resources Action Programme, UK

3 WASTE FLOWS IN THE EU

The goal of this chapter has been to obtain the data about total current and future waste amounts, as have been assessed by various studies in recent years. The availability of data on waste generation and composition is crucial for conducting analyses on the environmental pressures caused by wastes, on waste prevention policy options, and on the role of innovation in driving waste prevention.

The chapter is based on a survey of future trends in waste generation and composition that could be expected to occur, including waste composition and generation in future, calculated by such parameters as socioeconomic conditions, demographics, household consumption patterns, GDP (per capita) generated, consumer behaviour, and future technologies. The analysis of these trends has been only at a basic level, thus the estimation of future waste amounts is only indicative.

Below is a list for the collected information (from EU-25).

Socio-economic indicators:

- Population (2004)
- Average annual population change (1995-2004)
- GDP/capita PPS (2004)
- Annual average change of GDP/capita PPS (2000-2004)
- Textile and leather waste generation (1990-2004)
- Textile and leather HZW generation (1990-2004)
- Energy production waste generation (1990-2004)
- Energy production HZW generation (1990-2004)

Municipal solid waste:

- MSW generation (1990-2004)
- MSW composition (1980-2004 varying by member states according to availability)

Specific waste flows:

- Waste oil generation (1990-2004)
- Packaging waste generation (1990-2004)
- Sewage sludge generation (1990-2004)
- Hazardous waste generation (1990-2004)

Industrial/production waste:

- Manufacturing waste generation (1990-2004)
- Construction and demolition waste generation (1990-2004)
- Mining and quarrying waste generation (1990-2004)
- Agriculture waste generation (1990-2004)
- Agriculture HZW generation (1990-2004)

Based on the information gained from this analysis, the results of an expert workshop, and of the potential environmental impacts of the various waste flows investigated, the consortium has decided to apply a series of different approaches to analyse the role of waste prevention policy and more specifically, innovation policy in waste prevention. The selected approaches and waste flows were the following:

- Product oriented approach (example waste flows: WEEE and end-of-life vehicles)
- Material oriented approach (examples waste flow: PVC)
- Waste stream oriented approach (example waste flow: packaging waste)
- Consumption oriented approach (example waste flow: textile waste)
- Sector oriented approach (example waste flow: construction and demolition waste)

For these data flows a more detailed analysis has been carried out.

3.1 General Outlook on Waste Flows

The dataset collected on the waste flows arising in the EU-25 at a member state level are presented in detail in the Appendix 1 the enclosed CD. This subchapter summarises the results of the information collection.

3.1.1 Municipal Solid Waste

Data coverage on municipal solid waste generation is good in EU-25. Only in some of the EU-10 countries there are one or two missing years from the 1990-2004 time series. Composition data are available only from EU-15 and a few New Member States. In some cases even time series are available; however, as discussed later in the waste composition subchapter, national characteristics are less obvious than differences between urban and rural areas.

Data quality for absolute municipal solid waste is relatively good. However, in some countries (e.g., Malta, Estonia, and Slovakia) some hectic, significant changes can be observed in the time series, which might be caused by weak data management.

Data on MSW generation per capita shows that in the EU-15 waste generation is generally significantly higher than in the EU-10, as can be seen in fig. 3.1. However, a direct correlation with GDP PPS is not recognisable, and when analysing the data in a time series this relationship is even less obvious; e.g., there are examples of decreasing MSW generation levels and growing GDP/capita also in lower and higher GDP level countries (e.g. Slovenia, the United Kingdom or Lithuania, as indicated in Figure 3.2).

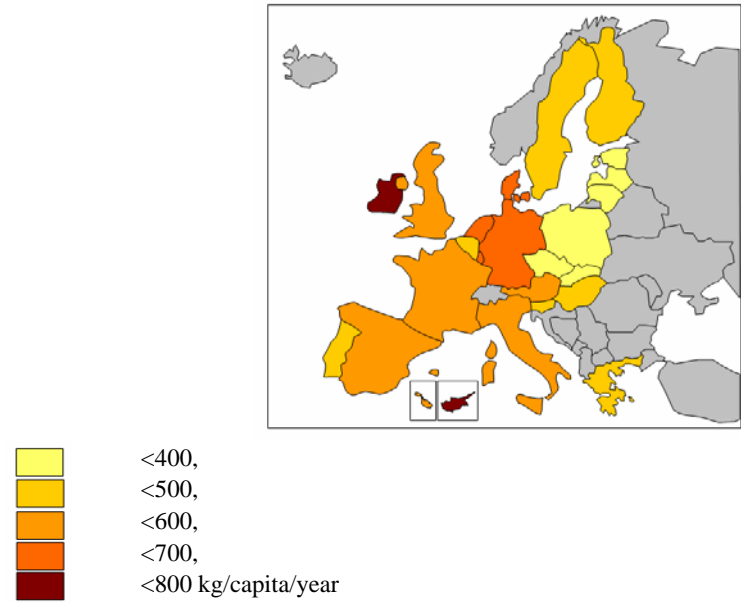

Source: Table 1 of Appendix

Figure 3.1: Municipal Solid Waste (MSW) generation per capita (2001)

The following charts in Figure 3.2 are visualising MSW generation trends. The countries are presented on five charts for better visualisation

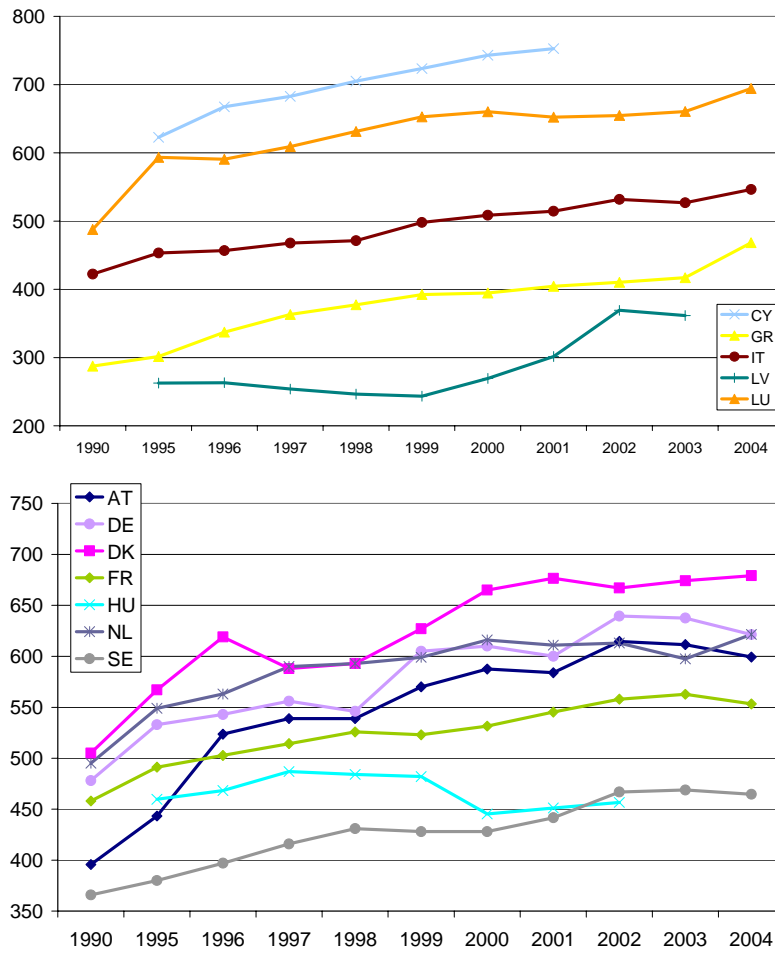

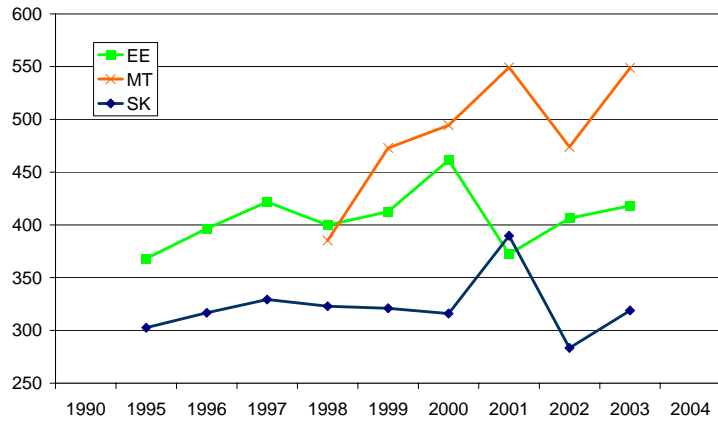
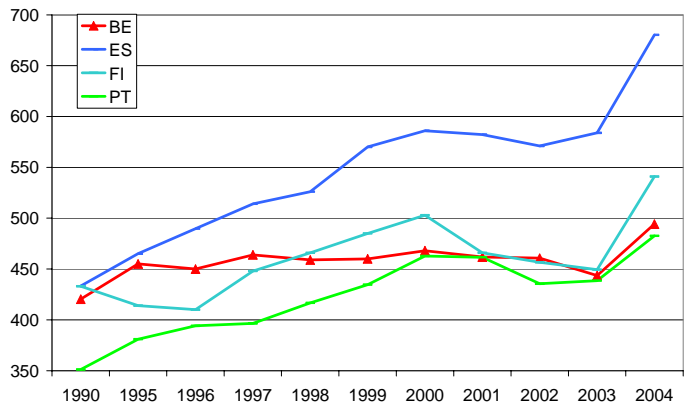
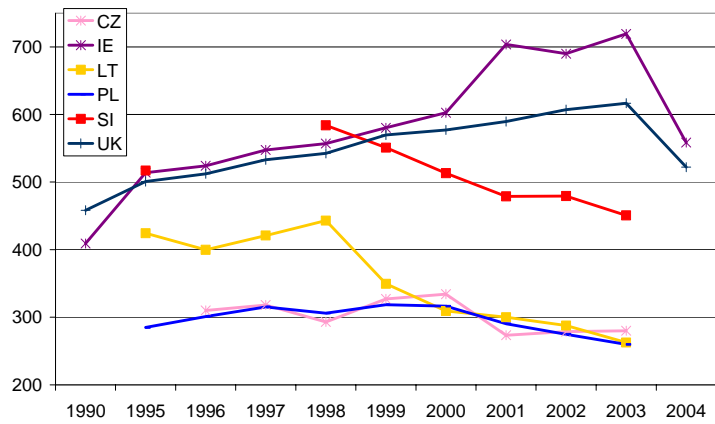

Figure 3.2: MSW generation trends, y-axis are annual kg/capita (please note that the y-axis is not crossing at 0 kg/capita - for better visibility), legends are 2-letter ISO country codes. Source: Table 1 in Appendix 1

It is difficult to recognise country-characteristic composition patterns. On the contrary it has been proven that MSW composition can be more determined by the rural-urban differences than differences between countries (SAEFL, 2003). In order to provide a picture on the overall MSW composition, average MSW compositions are presented below for EU-15 and the New Member States (plus Romania, Bulgaria).

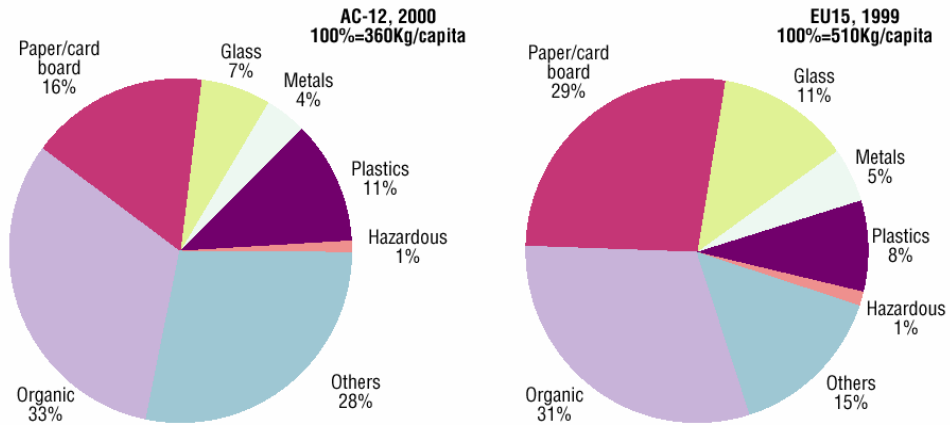
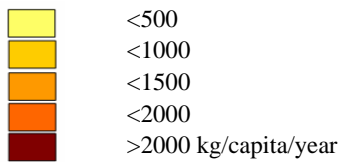
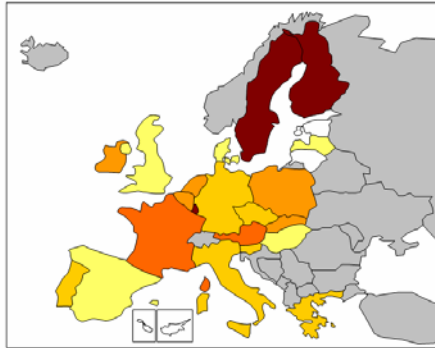

Figure 3.3: Average MSW composition and total generation (kg/capita) for EU-15 (1999) and AC-12 (=New Member States, Romania and Bulgaria) (2000) Source: Bodo, P. and Nemeskeri, R. (2004)

3.1.2 Industrial (production) waste

Data on production waste are available to a much less extent than municipal solid waste. In certain countries this type of data is totally missing, in others data are available only for a few years. Therefore it is difficult to select a single year where there is an EU-wide coverage of data. Hence, in order to be able to compare the countries, for each country the last reported value is presented on a per capita base.



Source: Table 3 in Appendix 1

Figure 3.4: Manufacturing waste

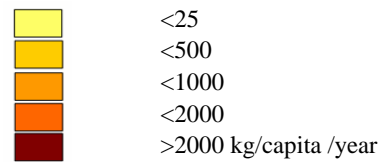
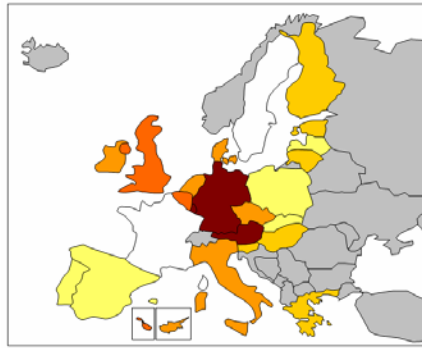

Source: Table 4 in Appendix 1

Figure 3.5: Construction and demolition waste

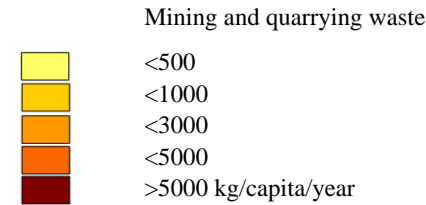
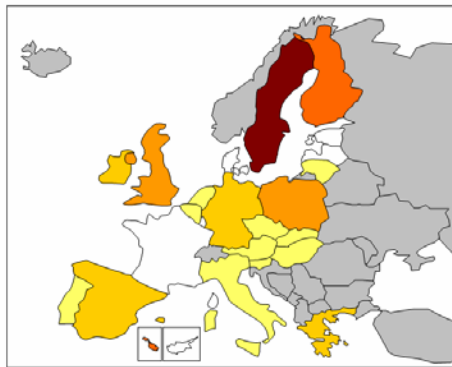

Source: Table 5 in Appendix 1

Figure 3.6 Mining and quarrying waste

Industrial waste data runs very wide range across the Member States, and even within one country the fluctuation in the time series is very high. Examples include:

- manufacturing waste (Luxemburg – above 3000 kg/capita/year; Finland, Sweden – around 2000 kg/capita/year; while Spain – around 7 kg/capita/year)
- construction waste (Luxemburg – above 5500 kg/capita/year; Austria, Germany – around 3000 kg/capita/year; while Spain, Portugal, Poland and Slovakia – at or below 10 kg/capita/year)
- mining and quarrying waste (Sweden – above 6000 kg/capita/year; Finland – above 4000 kg/capita/year; while Czech Republic – 66 kg/capita/year)

The above shows that data quality for production waste is not adequate for comparing countries and trends. Poor monitoring, non-standard data category application, weak reporting and data management practices are among the potential causes of poor data quality.

3.1.3 Specific Waste Flows

The implementation plan has specified not just sources of waste (households, different industrial branches), but also certain specific waste flows. Waste oil, packaging waste, sewage sludge and hazardous waste have been selected as specific waste flows to examine.

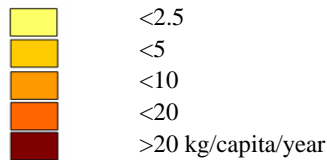
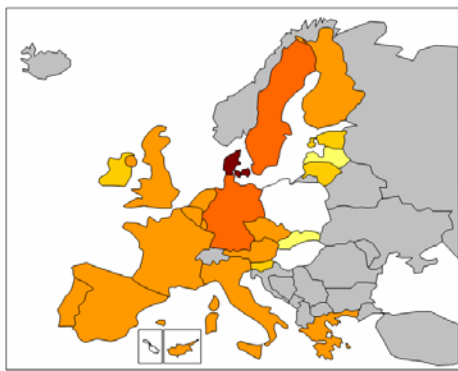

Source: Table 6 in Appendix 1

Figure 3.7: Waste oil

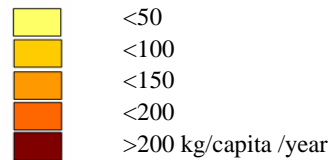
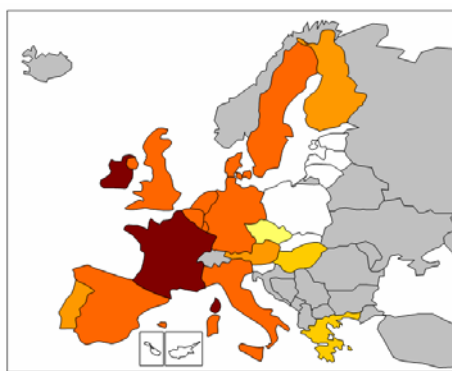
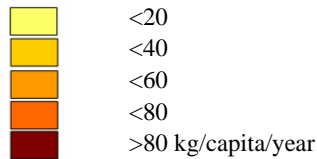
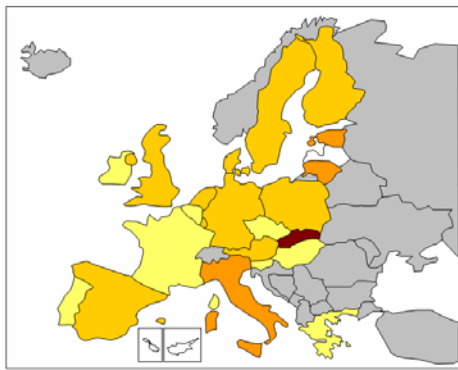

Table 7 in Appendix 1

Figure 3.8: Packaging waste



Source: Table 8 in Appendix 1

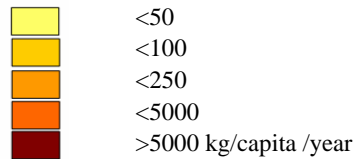
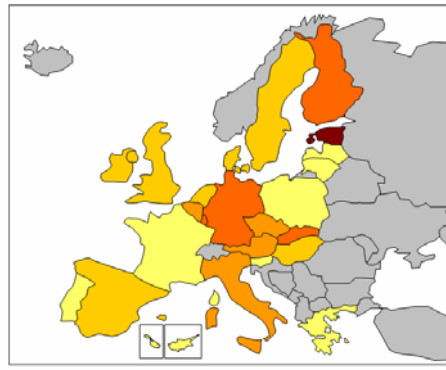

Table 9 in Appendix 1

Figure 3.9: Sewage sludge

Figure 3.10: Hazardous waste

Waste oil shows a relatively even generation distribution throughout the EU. As it is believed to correlate with the level of car use, the New Member States with a lower par capita car use level show slightly lower waste oil generation levels. Denmark's relatively higher (cc. 30 kg/ capita/year) level is the result of a DTCW estimation based on the correlation with car use. However, based on values of earlier years a lower, closer-to-average value is also possible.

Packaging waste generation is distributed evenly throughout the EU. Obviously the level of consumption and packaging has a close link, however the data shows that Austria and Finland was able to relatively decouple packaging waste generation, while France is producing more packaging waste than countries with similar consumption levels. In the New Member States Hungary and the Czech Republic show lower levels, which can be connected their general lower level of consumption as well as different consumption patterns. Nevertheless, the very low packaging waste generation level in the Czech Republic questions data quality.

Sewage sludge is also produced relatively evenly on a per capita basis. Slovakia has outstandingly high value, which is difficult to explain. One reason could be a high level of erosion, which partly goes through the sewage system, however there are also other mountainous countries in the EU. One other reason could be data quality and the combination of the two is also possible.

Hazardous waste is generated (or reported to be generated) at much more different levels than the previous waste streams. A huge anomaly exists in case of Estonia, where hazardous waste is produced at orders of magnitudes higher level than in other countries. This is because of its special energy sector relying on oil shale, which produces a very high alkalinity, high volume waste stream, regarded as 'minor hazard' hazardous waste, as indicated in table 3.1.

Table 3.1: Main waste generators in Estonia

	1993	1994	1995	1996	1997	1998	1999
I hazard class – extremely hazardous waste (th. t)	0.028	0.033	0.078	0.044	0.075	0.037	0.052
II hazard class – highly hazardous waste (th. t)	9.420	10.126	11.837	9.988	22.470	14.892	6.664
III hazard class – moderately hazardous waste (th. t)	1536.180	1508.822	1452.476	1531.796	1581.429	1225.274	614.467
IV hazard class – wastes of minor hazard (th. t)	6185.670	5956.595	5808.963	6137.042	5756.856	5031.456	5238.338

“As main waste generators in Estonia are oil shale mining, oil shale chemistry and energy industry, therefore also in volume of hazardous waste are dominating oil shale ashes and semi-coke. Most waste generated at the production of oil shale energy and in chemical industry is considered hazardous, due to their high alkalinity, in most cases they belong into IV hazard class. Other types of hazardous wastes generated in high amounts include:

- Waste of IV hazard class: sludge from wastewater treatment plants containing heavy metals, sludge from wastewater and combined sewerage, faecal matter;
- Waste of III hazard class: ballast and bilge water of ships, sawdust containing hazardous substances, mixed waste of hospitals, fuel and fuel oil waste and tank sediments;
- Waste of II hazard class: lead batteries, bitumen and asphalt waste;
- Waste of I hazard class: low and high pressure mercury lamps, nickel-cadmium accumulators.

In 1999 the total of 10.85 million tons of waste were generated, of which the amount of hazardous waste was 5.86 million tons, including oil shale ashes and semi-coke 5.59 million tons (95% of the amount of generated hazardous waste).

In the period 1993-1999 the amounts of hazardous waste have decreased ca 24% (from 7.73 million tons to 5.86 million tons) mainly due to the decrease of the production of oil shale energy and shale oil (figure 5.3). Reason for the decrease is also re-structuring of economy and accompanying decrease or alteration of production (including total stoppage of production in several branches of industry).”

Source: EEIC (2001)

Also among the other countries differences are considerable. However, from the data it is not obvious the cause of the differences is monitoring, data management or actual difference due to different production and consumption patterns.

3.1.4 Summary on waste flows

In the following table 3.2 EU-25 generation figures are estimated from the available information. Most often the available data covers a good majority of the EU-25 population, and thus the calculated total generation levels are assumed to contain low level of error.

Table 3.2: Estimation of total yearly load from certain sources or of certain waste streams in the EU

Waste type	Range (kg / capita / year)	Weighted average (kg/capita / year)	Percentage of EU population that the available data covers	Calculated EU-25 generation (Million ton/year)
Municipal Solid Waste	260 – 753	531.22	100	242.9
Manufacturing	7.6 – 3188	1064	98.7	381.6
Textile and Leather	2.6 – 102.8	18.00	77.1	8.23
Textile and Leather HZW	0 – 1.47	0.45	60.0	0.21
Construction and demolition	2.59 – 5580	1092	84.9	499.4
Mining and quarrying	2.58 – 6064	823.0	84.6	376.3
Energy production	2.5 – 880.1	201.5	63.7	92.1
Energy production HZW	0.25 – 13.02	1.49	35.3	0.68
Waste from Agriculture	7.41 – 14074	1318	40.3	602.6
HZW from Agriculture	0.1 – 3.9	0.31	32.7	0.14
Waste oil	1.1 – 30.9	7.71	89.3	3.52
Sewage sludge	2.39 – 105.6	27.54	99.2	12.59
Hazardous waste	4.1 – 5581	127.2	100	58.16
Packaging waste	12.04 – 211	172.5	88.2	78.87

3.1.5 Future waste trends and scenarios

In 2002, the European Topic Centre on Resources and Waste Management (ETC/RWM) initiated the development of a macro-level module on prospective analysis. The aim was to provide an assessment of the likely, future trends of waste quantities and material flows through the design of scenarios. The following is based on the ETC/RWM working paper ‘Outlook for waste and material flows Baseline and alternative scenarios’ (ETC/RWM, 2005).

This subchapter is summarising the main results and more detailed information is located in Appendix 1.

3.1.5.1 Methodology

Depending on the nature of the respective waste and/or material flow, three modelling types are used for the baseline projections for material flows and waste. In the general modelling type, the links in the past developments in quantities of waste/materials, economic activities, number of households/size of population have been used for scenarios projections of economic activities and other demographic variables.

In addition to the general modelling type, a population type model for projection of end-of-life-vehicles is used to project the amount of waste oils and tyres from cars. The time horizon for the projections is 2020.

The projections for waste generation include eight streams which are either large streams or subject to specific political measures. It should be noted that the streams cannot be aggregated as there is some overlap between paper and cardboard, glass, packaging and municipal waste. Key economic

and demographic assumptions regarding the elaborated baseline and low growth scenarios are presented in the following table 3.3.

Table 3.3: Trends in key economic and demographic assumptions

	Baseline scenario			Low growth scenario		
	Gross Domestic product	Households expenditure	Gross Value Added	Gross Domestic product	Households expenditure	Gross Value Added
EU15						
2000-10	27%	26%	29%	18%	17%	20%
2000-20	60%	57%	62%	39%	37%	42%
2000-30	98%	92%	102%	63%	57%	67%
EU10						
2000-10	46%	46%	47%	39%	38%	40%
2000-20	108%	113%	113%	94%	100%	99%
2000-30	179%	186%	185%	155%	160%	161%
CC3						
2000-10	44%	39%	43%	47%	32%	45%
2000-20	147%	137%	144%	140%	111%	133%
2000-30	291%	279%	286%	267%	224%	256%

Source: (ETC/RWM, 2005)

It should be noted that the waste outlooks have not been elaborated for both EU-15 and EU-10 for all wastes. In the following emphasis will be on the baseline scenario. Nevertheless, also results from the Low growth scenario will be mentioned.

3.1.5.2 Municipal solid waste (MSW)

The Western European countries (former EU-15, Norway and Switzerland) produce more MSW per capita than the new EU Member States and the candidate countries. The Baseline scenario estimates an increase in quantity in 2020 of approximately 20-25% for the EU-15 and 15-20% for the new EU Member States. For the candidate countries, Bulgaria and Romania (CC2), the change is estimated to 5-10% and less than 5% for the EEA countries, Norway and Switzerland.

For the EU-10, Bulgaria and Romania the projections are less solid which is caused by the situation in Eastern Europe in the 1990s. In the past, substantial changes in the economic situation have affected the household income and consequently the generation of waste. The continuation of past trends is rather unlikely, especially considering a projected increase in household consumption expenditure of approximately 4% p.a. The projected consumption expenditure for the EU-15 is approximately 2.3% p.a. For this reason, the generation of municipal waste for the EU-10 and CC2 is likely to increase more than estimated by the model.

3.1.5.3 Biodegradable municipal waste (BMW)

The Landfill Directive is the main legislative measure for the management of biodegradable municipal waste. It is assumed that the share of BMW in municipal waste given in 1995 remains constant. Subsequently, it is estimated that due to the Landfill Directive, the former EU-15 is to reduce the amounts of BMW landfilled in 2006 by 15 million tonnes. As a result, the waste diverted from landfills will be directed towards other waste management options. In 2009, the amount will be 28 million tonnes, and in 2016 it is 41 million tonnes. However, data on the BMW shares are poor, and large uncertainty is attached to the estimate.

3.1.5.4 Industrial waste

According to the Baseline scenario for the EU-15 industrial, waste is projected to increase by 60-65% in 2020 compared to 2000. In comparison, the Low growth scenario projects an increase of 45%.

3.1.5.5 Waste from the construction and demolition sector

The Baseline scenario estimates that waste from the construction and demolition sector in the EU-15 is to increase by approximately 30-35% by 2020. On the other hand, the Low growth scenario estimates a more moderate increase of 15-20%. Due to differences in composition of waste from the construction and demolition sector, the estimate includes large differences between countries. When the results are compared with the estimated growth in economic activity, it is expected that decoupling will take place over the twenty-year period.

3.1.5.6 Paper and cardboard

The Baseline scenario results in an increase of paper consumption of 60-65% in 2020, whereas the Low growth scenario estimates a more moderate growth of 40-45%. Both the past trends and the projected trends for each country imply no significant changes in the projections. Apparently, the growth continues at the same rate after 2000.

3.1.5.7 Glass

The growth in consumption of container glass is projected to be moderate. Hence, the Baseline scenario estimates an increase of 45-50% in 2020, while the Low growth scenario estimates a 25-30% increase. Similarly to the waste from the construction and demolition sector, rather big differences between the estimated trends for countries are observed.

3.1.5.8 Packaging

The Baseline scenario estimates the total amount of packaging waste from the former EU-15 Member States to increase by 20-25% over the period from 2000 to 2010. The Low growth scenario produces lower increases of approx. 15% in 2010.

3.1.5.9 Tyres and Waste oil

The projected increases in used tyres and waste oil of the baseline scenario are almost identical as they are directly linked to the projection of vehicles. While the projections of the EU-15 show a modest increase, the waste streams in the EU-10 are projected to increase by 70-75% and by 115% in Bulgaria and Romania. A relative decoupling from the GDP could take place in the EU-15 and the new EU-10. This is, however, not likely to happen for the two candidate countries.

3.2 Waste flows selected for further analysis

3.2.1 Selection of waste flows

Based on the results of the general outlook and the experts' view collected before and during the advisory workshop the following criteria have been identified in order to be able to select waste flows for further analysis:

- Waste flow with significant environmental load through life-time
- Problem of increasing significance
- Already available examples of waste prevention policies
- Potential for innovation
- Allows different levels of innovation

In simple words the group of waste flows have been searched, which cause (1) high and/or (2) growing environmental problems, both (3) policy and (4) technical innovation exists at least partly and (5) offers a mix of approaches to be analysed.

In order to be able to handle different levels of innovation (from process through product to system innovation) five different approaches have been selected:

- Product oriented – waste issues of one specific product
- Material oriented – handling one certain problematic material
- Waste stream oriented – addressing a type of waste stream from multiple source
- Consumption oriented – when waste appears at the consumer
- Sector oriented – the waste production of a certain sector

In case of product oriented waste flows, electronics and cars seemed to be the obvious decisions, since these products have very high environmental load, their waste generation is rapidly growing and both policy and technical innovation exist on the field.

In case of material oriented waste flows, PVC has been selected, since this material is used in large amounts in several sectors, there are methods for substitution or limited use of additives, its waste management is very problematic, and in certain countries some policy steps have happened to mitigate environmental load from PVC waste.

In case of waste stream oriented analysis, the obvious choice have been packaging, which is used throughout the economy, provides a variety of alternatives, very much addressed by policy intentions and contribute to a growing part of the total waste generation.

For a consumption oriented analysis, textile has been selected since around 75% of the post-consumer waste is landfilled or incinerated resulting in a very significant amount of lost resources. Moreover, as textile fibre and product production is located more and more outside Europe, this contributes to a growing global environmental load, where brands needs new strategies and policy maker needs new policies to enable consumers to chose responsibly.

For sector oriented analysis construction and demolition waste has been selected, being 25% of the total waste generation in the EU and representing an extremely high amount of waste resources.

3.2.2 Construction and demolition waste

Sources used for this subchapter are ETC/RWM (2006), SYMONDS (1999), EEA (2002).

Construction and demolition waste is made up of two individual components: construction waste and demolition waste. It arises from activities such as the construction of buildings and civil infrastructure, total or partial demolition of buildings and civil infrastructure, road planning and maintenance. In some countries even materials from land levelling are regarded as construction and demolition waste.

Construction and demolition waste makes up approximately 25% of all waste generated in the EU with a large proportion arising from the demolition and renovation of old buildings. It is made up of numerous materials including concrete, bricks, wood, glass, metals, plastic, solvents, asbestos and excavated soil, many of which can be recycled in one way or another. The per capita generation quantities are described in the figure below.

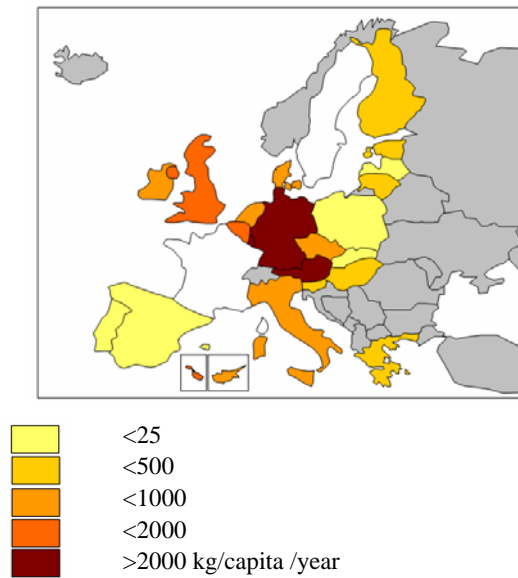

Figure 3.11: Construction and demolition waste

Waste amounts per capita vary considerably from one country to another. There are possible explanations to these differences, but they also point to a very basic problem of the reliability and comparability of the available waste data.

The differences can partly be explained by the economic and cultural differences that exist between countries. There are also differences in definitions used, for instance, the reason for the high level in Austria and Germany can be explained by the fact that these countries include excavated soil and stones in the waste data. The different rates could also, to some extent, be explained by the different traditions for registration and use of this kind of waste. For instance, if bricks and concrete are used directly as construction material for small roads and paths or as filling material at the site, it will often not be registered as waste.

Altogether it is estimated that some 500 million tons of construction and demolition waste is generated annually in the EU-15. Its composition is differing from member states to member states (having e.g. a higher share of wood waste in Scandinavian countries), but the overall average composition can be summarised by the figure below:

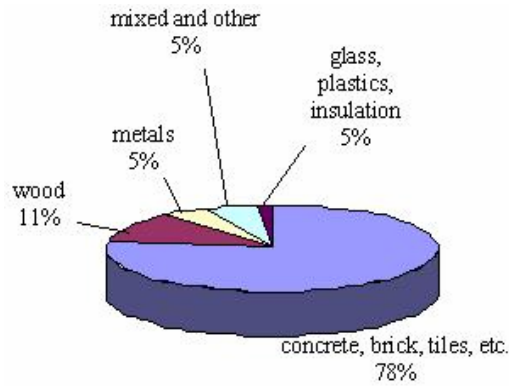

Figure 3.12: Composition of C&D waste in the EU. Source: ETC/RWM (2006); Please note that the numbers on the figure add up to 104%.

The main methods used to treat and dispose of construction and demolition waste include landfill, incineration and recycling with some countries obtaining recycling rates as high as 80%. It appears that the percentage of recycling is more than 80% in Denmark, Germany and the Netherlands. Finland, Ireland and Italy recycle 30–50%, while the recycling percentage in Luxembourg is 10%. Recycling includes crushing of bricks and concrete for use as filling in new building materials or simply as filling under new constructions to replace the use of gravel. In at least one country, Germany, use of non-contaminated excavated soil and smaller amounts of non-contaminated demolition and road construction waste to fill old sand and gravel pits for safety reasons is regarded as recovery.

3.2.3 Textile waste

In the European Union, consumers discard every year 5.8 million tons of textiles. At the moment only about 1.5 million tons (25%) of these post consumer textiles are recycled by charity and industrial enterprises. About 1 million tons are exported directly to Third World countries: about 0.5 million tons are converted to various products and sold inside the European Union. The remaining 4.3 million tons (75%) of these post consumer textiles are landfilled or burnt in municipal waste incinerators, representing an enormous unused source of raw materials. Of the 500.000 tons that is recycled, the main applications are wiping rags, fibre production and application in the paper industry (S. Frankenhuys & Zn. B.V., 2001).

In addition to the above also a large quantity of waste is generated in the manufacturing process. From textile and leather manufacturing 8.23 million tons of waste is generated (estimated value based on 77% coverage of the Community's population), from which 0.21 million tons are hazardous waste.

3.2.4 WEEE and EoLV

Information sources for this subchapter are ETC/RWM (2006), EC JRC (2005), EC DG Environment (2006).

3.2.4.1 WEEE

WEEE is one of the fastest growing waste streams in the European Union and makes up approximately 4% of municipal waste. Each EU citizen currently produces around 17-20 kg of e-waste per year and thus the waste stream adds up to 9-10 million tons at the Community level. Some 90% of this waste is still landfilled, incinerated, or recovered without any pre-treatment. Expected growth rates are between 3 and 5% each year. This means that in five years time, 16-28% more WEEE will be generated and in 12 years the amount is expected to double. This rapid growth rate is due to the fast pace of technological development, especially in information technology (IT) which have resulted in the more frequent replacement of electrical and electronic equipment by industry.

An estimate of the composition of WEEE arising is shown below. As can be seen, iron and steel are the most common materials found in electrical and electronic equipment and account for almost half of the total weight of WEEE. Plastics are the second largest component by weight representing approximately 21% of WEEE. Non-ferrous metals including precious metals represent approximately 13% of the total weight of WEEE and glass around 5%.

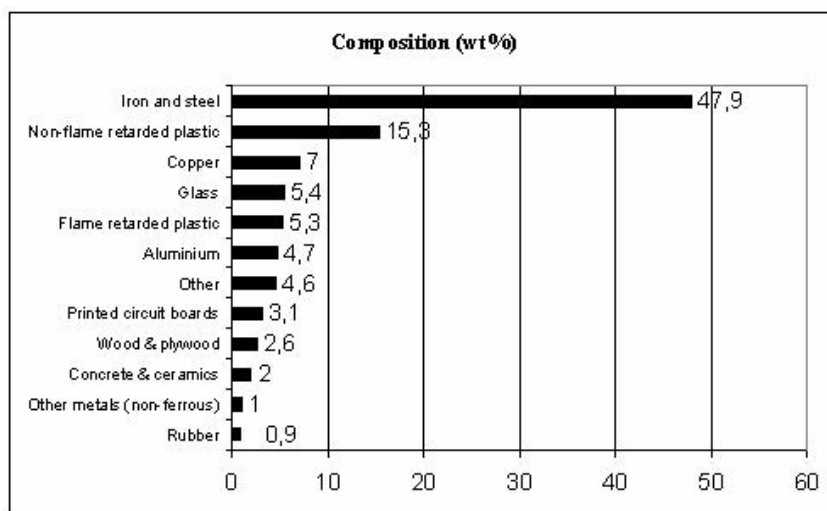

Figure 3.13: Average composition of WEEE in EU-25. Source: ETC/RWM (2006)

3.2.4.2 End-of-life vehicles

End-of-life vehicles are defined as cars that hold up to a maximum of eight passengers in addition to the driver, trucks and lorries that are used to carry goods up to a maximum mass of 3.5 tonnes. Thus their sources range from households to commercial and industrial uses.

In the year 2000, 13.4 million cars were scrapped in the EU. This is projected to increase by 21% by 2015 to 17 million. Cars are composed of numerous different materials. Approximately 75% of the weight of a car is made up of steel and aluminium, most of which is recycled. Other materials present include lead, mercury, cadmium and hexavalent chromium, in addition to other dangerous substances including anti-freeze, brake fluid and oils that, if not properly managed, may cause significant environmental pollution. The remainder is composed of plastic which is recycled, incinerated or landfilled.

Note: Please note that the above data is EU-15 only. The estimated EU-25 level might be around 15-16 million tons, since car ownership is lower and the average lifetime of cars is longer in Eastern

Europe. The fact that many used Western European car receives a prolonged lifetime by exporting them to Eastern Europe is also a decreasing factor for the total amount.

Other source (GHK, 2006) indicates a level of 15 million tons by 2015. Average composition of an ELV in 2015 estimated to be 65% ferrous metals, 12% plastics, 9% non-ferrous metals, with the percentage of plastics and non-ferrous metals rising by a couple of percent in subsequent years. The expected increase is due to the increasing number of vehicle deregistrations as well as the increasing average weight of deregistered cars (from around 960 kg to 1025 kg).

3.2.5 PVC waste

This subchapter is based on EC (2000).

Polyvinyl chloride (PVC) is a synthetic polymer material (or resin), which is built up by the repetitive addition of the monomer vinyl chloride (VCM) with the formula $\text{CH}_2 = \text{CHCl}$. PVC has thus the same structure as polyethylene except for the presence of chlorine. The chlorine in PVC represents 57% of the weight of the pure polymer resin. 35% of chlorine from the chloralkali electrolysis eventually ends up in PVC, which thus constitutes the largest single use.

Pure PVC is a rigid material, which is mechanically tough, fairly good weather resistant, water and chemicals resistant, electrically insulating, but relatively unstable to heat and light. Heat and ultraviolet light lead to a loss of chlorine in the form of hydrogen chloride (HCl). This can be avoided through the addition of stabilisers. Stabilisers are often composed of salts of metals like lead, barium, calcium or cadmium, or organotin compounds.

The mechanical properties of PVC can be modified through the addition of low molecular weight compounds that mix with the polymer matrix. Addition of these so-called plasticisers in various amounts generates materials with an important versatility of properties that has led to the use of PVC in a vast range of applications. The main types of plasticisers used are esters of organic acids, mainly phthalates and adipates. The main distinction between the numerous applications is between « rigid PVC » (accounting for about two thirds of total use) and « flexible PVC » (accounting for about one third).

The following table 3.4 presents the main applications of PVC in Europe and the percentage of overall use. The great number of applications is characterised by a wide range of lifetimes ranging from several months to more than 50 years for some construction products. The main applications of PVC in Europe are in the building sector, which accounts for 57% of all uses and where products also have the longest average lifetimes.

Table 3.4a: Main use categories of PVC in Europe

Use / application	Percentage	Average life-time (years)
Building	57	10 to 50
Packaging	9	1
Furniture	1	17
Other household appliances	18	11
Electric/Electronic	7	21
Automotive	7	12
Others	1	2-10

The total quantity of PVC waste is a function of PVC consumption. However, due to lifespans, which can reach up to 50 years and more for some applications such as pipes and profiles, there is a time-lag between PVC consumption and PVC presence in the waste stream. PVC products reached significant market share in the 1960's. Considering lifespans of about 30 years and more, a significant increase of PVC waste quantities is expected to start around 2010.

Table 3.4b: PVC main waste sources

Waste source	1999 (Mtons)
Construction and demolition waste	1
MSW	1
Packaging waste	0.7
WEEE and EoLV	0.7

Compared to the current situation, it is expected that the composition of PVC post-consumer waste arising by product group will change. The share of PVC building waste and waste from household and commercial products will increase, whereas the contribution of packaging is expected to decrease significantly. The proportion of flexible PVC waste will also decrease.

Table 3.4c: PVC main waste types

Waste type	1999	1999 mgmt.	2010	2010 mgmt.	2020	2020 mgmt.
PVC total	4.1		5.3		7.1	
PVC post-consumer	3.6	2.6 to 2.9 l. 0.6 i. 0.1 m.r.	4.7	0.4 to 0.8 m.r.	6.2	2.8 l. 2.5 i. 0.55 to 1.2 m.r.
PVC pre-consumer	0.5	0.42 m.r.	0.6		0.9	

Landfilling is the most common waste management route for PVC waste. Exact figures on the landfilling of PVC waste are not known and there are large differences between various estimations ranging up to 2.9 million tonnes of PVC waste being landfilled every year. It can be estimated that several tens of million tonnes of PVC waste have already been landfilled during the past 30 years. PVC products disposed of in landfills will certainly contribute to the formation of dioxins and furans during accidental landfill fires, but the quantitative contribution cannot currently be estimated due to the inherent difficulties in obtaining the necessary data. In order to further assess and quantify the environmental impacts of the landfilling of PVC, further research would be necessary to study the potential degradation of PVC polymer, the release of stabilisers and plasticisers, as well as the environmental contribution of phthalates to the leachates and gaseous emissions from landfills.

PVC represents about 10% of the plastic fraction **incinerated** and about 0.7% of the total quantity of waste incinerated. PVC waste contributes between 38% and 66% of the chlorine content in waste streams being incinerated. An assessment of the quantities of flue gas cleaning residues resulting from the incineration of PVC waste concluded that the incineration of 1kg of PVC generates on average between 1 and 1.4 kg of residues for the dry process with lime, semi-dry and semi-wet wet processes. With the use of sodium hydrogen-carbonate as neutralisation agents in semi-dry process, 1 kg of PVC generates about 0.8 kg of residues. In case of wet processes, between 0.4 and 0.9 kg of liquid effluent is generated. The flue gas cleaning residues are classified as hazardous waste. The residues are generated separately (in particular in semi-wet and wet systems) or mixed with fly ash. The residues contain the neutralisation salts, the excess neutralisation agent as well as pollutants such as heavy metals and dioxins that were not destructed. Landfilling of the residues is, with some exceptions, the only option used within the Member States.

There appears to be no Member States where the **recycling** rate of post-consumer waste is significantly higher than the EU average. In some countries, collection schemes have been established, usually through voluntary approaches. However, the recycling rate is usually below 5% and is largely based on the down-cycling of packaging and cables.

3.2.6 Packaging waste

Sources of information for this subchapter: EC DG Environment (2006), ETC/RWM (2006)
Packaging is defined as any material which is used to contain, protect, handle, deliver and present goods. Items like glass bottles, plastic containers, aluminium cans, food wrappers, timber pallets and drums are all classified as packaging. Packaging waste can arise from a wide range of sources including supermarkets, retail outlets, manufacturing industries, households, hotels, hospitals, restaurants and transport companies.

Packaging waste represents up to 17% of the municipal waste stream. As it has a relatively short life, it soon becomes a waste that must be treated or disposed off. The estimated amount of packaging waste generation yearly in the Community is around 79 million tons. Packaging waste generation is distributed evenly throughout the EU. Obviously the level of consumption and packaging are closely linked, however the data shows that Austria and Finland was able to relatively decouple packaging waste generation, while France is producing more packaging waste than countries with similar consumption levels. In the New Member States Hungary and the Czech Republic show lower levels, which can be connected their general lower level of consumption as well as different consumption patterns. Nevertheless, the very low packaging waste generation level in the Czech Republic questions data quality. The average per capita packaging waste generation is presented on the figure below.

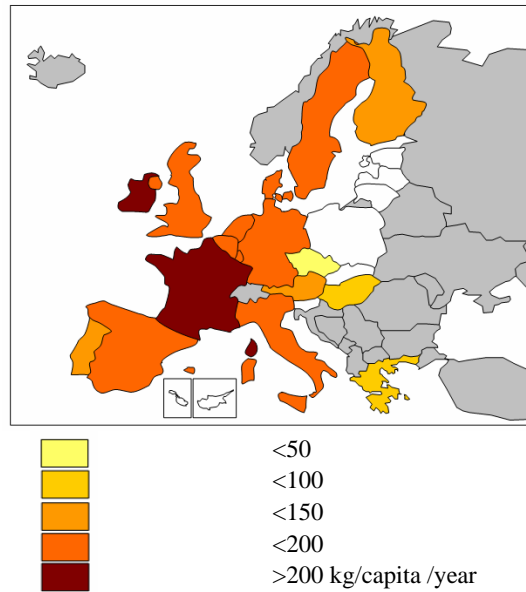

Figure 3.14: Packaging waste

The composition of packaging can be estimated based on ECOLAS-PIRA (2005):

Table 3.5: Reference flows (EU-15, 1997-2001)

	1997 (t)	1998 (t)	1999 (t)	2000 (t)	2001 (t)
Glass	14,986,689	15,148,101	15,378,179	14,903,182	14,611,610
PET bottles	9,662,216	9,856,749	10,093,441	10,294,880	10,707,805
Aluminium	439,557	457,942	441,688	462,838	463,100
Steel	3,956,015	4,121,474	3,975,195	4,165,541	4,167,896
PE film	9,962,216	9856749	10093441	10294880	10707805
Corrugated board	23,655,288	25,203,955	25,728,180	26,380,803	26,281,032

3.3 References

AEA Technology et al. (2003): The Composition of Municipal Solid Waste in Wales.
<http://www.wales.gov.uk/subienviroment/topics-e.htm#11>, December, 2003.

Bodo, P. and Nemeskeri, R., (2004): Techno-economic Outlooks of Waste Indicators in Candidate Countries. ESTO/IPTS, Seville, Spain.

Büll, U; Moser, G. & Dobson, G (2005): A standard is set - Analysing solid waste in five European Cities. Waste Management World, March-April, 005.

Christensen et al. (1998): Waste Technology. Teknisk Forlag A/S, Copenhagen (in Danish).

EC (2000) 'COM(2000)469 final' (Green Paper: Environmental Issues of PVC).

EC DG Environment (2006) websites captured in May 2006

http://ec.europa.eu/environment/waste/weee_index.htm

http://ec.europa.eu/environment/waste/elv_index.htm

http://ec.europa.eu/environment/waste/packaging_index.htm

EC JRC (2005) Draft final report JRC 12/1 updates - research study into implementation of WEEE Directive in EU 25 (by AEAT, REC, 2005).

ECOLAS-PIRA (2005) Study on the implementation of the Packaging Directive and options to strengthen prevention and re-use, Final report, 2005 February

http://ec.europa.eu/environment/waste/studies/packaging/050224_final_report.pdf

EEA (2002) Review of selected waste streams: Sewage sludge, construction and demolition waste, waste oils, waste from coal-fired power plants and biodegradable municipal waste, Technical Report No. 69.

EEIC (2001) The State of Environment in Estonia

http://enrin.grida.no/htmls/estonia/env2001/content/soe/waste_5-2.htm

ETC/RWM (2006) WasteBase Database <http://waste.eionet.eu.int/wastebase/>

ETC/RWM (2006) website captured in May 2006

<http://waste.eionet.europa.eu/waste/4> <http://waste.eionet.europa.eu/waste/6>

<http://waste.eionet.europa.eu/waste/8> <http://waste.eionet.europa.eu/waste/9>

EUROSTAT (2006) website (captured in March 2006)

http://epp.eurostat.ec.europa.eu/portal/page?_pageid=1996.45323734&_dad=portal&_schema=PORTAL&screen=welcomeref&open=/envir/milieu/waste&language=en&product=EU_MAIN_TREE&root=EU_MAIN_TREE&scrollto=0

GHK (2006) A study to examine the benefits of the End of Life Vehicles Directive and the costs and benefits of a revision of the 2015 targets for recycling, re-use and recovery under the ELV Directive, Final Report to DG Environment,

http://ec.europa.eu/environment/waste/pdf/study/final_report.pdf

ICSG, Information Circular, Waste Electric & Electronic Equipment (WEEE) May 2003

ICSG/IC/10.

IPPC secretariat (2005) CRF/NIR reporting to IPCC. <http://www.unfccc.int/>

Machol, R.E. (1965) (ed.) Systems Engineering Handbook. McGraw-Hill Book Company, New York, NY, USA.

McDougall, F; White P.; Franke, M. & Hindle, P. (2001): Integrated Solid Waste Management: a Life Cycle Inventory. Proctor & Gamble Technical Centres Limited. Blackwell Science Ltd. (refers to OECD).

OECD (2004): OECD Environmental Data Compendium 2004. OECD Publishing, Paris.

Pavlik Z., Kucera M. (eds.) (2002) Population Development in the Czech Republic 1990-2002

http://popin.natur.cuni.cz/html2/publications/papers/popdev02cz_en/shifts_in_population_size.pdf

Petersen, P & Domela, I (2003): Composition of household waste and options for home composting. Econet A/S and Carl Bro for the Danish Environmental Protection Agency. Environmental Project No. 868 2003. Copenhagen.

S. Frankenhuis & Zn. B.V. (2001) Project fiche: Innovative technologies for the economically sound identification and sorting of post-consumer textile
http://cordis.europa.eu/fetch?CALLER=FP6_PROJ_BRITE&ACTION=D&RCN=46913&DOC=7&CAT=PROJ&QUERY=1147182064870

SAEFL (2004): A Survey of the composition of household waste 2001/02. Environmental Series No. 356. Swiss Agency for the Environment, Forests and Landscape. Bern, 2004.

Skovgaard, M. et al. (2004): Prospective analysis on waste and material flows - Baseline and alternative scenarios. European Topic Centre on Waste and Material Flows, September 2004.

SYMONDS (1999) Construction and demolition waste management practices, and their economic impacts, Report to DGXI, European Commission
http://ec.europa.eu/environment/waste/studies/cdw/cdw_report.htm

Tucker et al (2006) Analysis of techno-economic development potentials to de-couple waste generation from economic growth – the case of municipal waste. ESTO. First draft report Monday, 20 March 2006.

Waste Base/DG Environment. Member States report in pursuance of Directive 94/62/EC on Packaging and Packaging Waste.

White, P.R.; Franke M. & Hindle, P. (1995): Integrated Solid Waste Management - A Life Cycle Inventory.

4 ENVIRONMENTAL IMPACTS OF WASTE STREAMS – IDENTIFICATION OF PREVENTION POTENTIAL

In order to identify waste materials or waste streams of main concern for prevention policy intervention, it is first necessary to characterise and if possible classify (by the use of e.g. a ranking process) the potential environmental impacts of waste materials. The effects of preventive actions spread through the whole life cycle of the material in question: the reuse of a glass bottle means that all upstream processes of sand extraction, glass bottle manufacture, and intermediate transport are unnecessary, in other words, saved.

When a life-cycle perspective is used, the type of downstream processes to treat and dispose of the waste materials also has influence on the savings obtained by a prevention action: if it is incineration flue gases, filter residues, slag and ashes are avoided; if it is land filling, methane emissions, and leakages are avoided; let alone the impacts and costs associated with collection and transport in any waste management mode. When prevention affects products or services, and not homogeneous materials, it is the combination of materials bearing the given product or service that is used for the analysis.

Once this knowledge of the materials is in place, an assessment of the waste streams consisting of different materials is undertaken. The material approach is therefore a first step creating *'building blocks'* that are used later in this report in an assessment of waste stream prevention. Hence, waste streams containing a mixture of different materials can be assessed according to their content of the examined materials.

Table 4.1: Qualitative correlation between waste streams and materials

Waste stream	Primary content of examined materials
Total Municipal Solid Waste	Plastics, iron, aluminium, paper and card, wood, mineral material, textiles, organic
Total Manufacturing	Plastics, iron, aluminium, paper and card, wood, mineral material, textiles, organic
Textile and Leather	Textiles: (poliester + natural fibres)
Textile and Leather HZW	The above plus heavy metals (**).
Construction and demolition	Plastics, iron, aluminium, paper and card, wood, mineral material
Mining and quarrying	Mineral material
Energy production waste	Mineral material
Energy production HZW	The above plus heavy metals (**).
Waste from Agriculture	Organic
HZW from Agriculture	The above plus fitosanitary chemicals (**).
Waste oil	Unspecified organic compounds of oil (**)
Sewage sludge	Unspecified organic compounds and heavy metals (**).
Hazardous waste	Metals, oil, plastics, inorganic and organic solvents (**)
Packaging waste	Plastic + paper + cardboard + glass + metals + textiles

NOTE: see Table 4.13 for an estimation of the percentages in Denmark.

(**) see Table 2.1 for specific examples of these substances.

In addition to the material specific approach, an overview assessment of hazardousness is made on the waste stream level.

When all upstream and downstream processes are covered, it is possible to compare whether it is the prevention of, for example, wasted metals, plastics, wood, organic matter, or paper that avoids

the largest environmental impacts. Such comparison is, however, conditioned to a given scenario of energy and material supply, and waste treatment. For instance, if the treatment option was not land filling, but incineration or recycling, then the savings obtained by prevention would NOT be the same.

The information resulting from this study can support future prevention policy formulation efforts concentrating on the waste materials, streams, products and treatments that currently (or in the future) result in the largest impact savings. It would also allow policy makers to identify potential policy intervention areas to achieve reduction of certain pressures/impacts, such as material, energy, and land resources use, and/or risks posed by environmental hazards associated with waste generation and treatment.

The geographical scale at which a prevention option/need ranking is used can also condition the applicability of the results. In general, the smaller the scale of the study (local < regional < national < international), the larger the feasibility of gathering specific and consistent data, because there is generally a higher homogeneity of geographical conditions and associated technological choices. The priorities necessary for weighting between the environmental impact categories are also easier to set at small scale, and thereby also the decision-making criteria for elaborating a prioritisation list.

These issues reveal that the classification of waste materials for the purpose of prevention, despite being a very desirable input for policy formulation, is an activity that has large data requirements. For a bottom-up approach, it is necessary to quantify actual (or estimated) pressures, such as emissions, energy and material resources inputs and outputs. The auxiliary energy and material inputs to the system have to be defined as well.

This chapter has two fundamental goals:

- The main goal is to identify waste materials with a high contribution to environmental impacts throughout their lifetimes. The indicators studied for environmental impacts are the resource, energy and the hazardousness indicators described in Chapter 2. The prioritisation of materials in waste, or the waste streams themselves would enable to identify those waste streams that should be of main concern for future prevention policy. Hence, the avoidance of the identified waste streams through prevention could lead to large environmental impact savings.
- A secondary goal of this impact assessment is to create ‘building blocks’ that allow further calculating and assessing the environmental impacts of prevention actions.

4.1 Waste impact assessment methodology

This environmental impact assessment concerns the identification of wastes whose prevention would have a high potential to reduce the overall environmental impacts of resource use throughout the life-cycle. The prioritisation of prevention actions of waste materials depends on:

- the *quantities* in which they get generated,
- their *impacts* during the life cycle,
- their specific *physical and chemical characteristics with the potential to harm* (e.g., toxicity, occurrence, mobility into various environmental media, eventually into the human body with the risk of causing illnesses, etc.),
- the *treatments* they undergo.

The methodological approach used to produce a ranking prioritisation list of the materials is based on simplified, life-cycle based, environmental indicators, as described in Chapter 2: a combined *resource and energy indicator* (Section 4.3) as indicators for the impacts in the life cycle, and a

hazardousness indicator (Section 4.4) referring to potential risks related to toxicity/hazard and occurrence. Thus, the environmental impacts are represented by indicators that are meant to capture the largest impacts, rather than covering a wide spectrum of emissions and impact categories. The presented indicators are simple, easy to understand, easy to convert to policy, and cover all relevant aspects of prevention (quantitative and qualitative). Indicators are calculated for different treatment scenarios and should be related to the actual quantities generated in a specific region.

The results arising from the two calculations of the indicators have been combined in a ranking from which the most suitable candidate waste materials for waste prevention can be selected.

From the waste materials recorded, the waste materials that seem to pose the most significant environmental pressures are identified, based on their substantial volumes and hazardous properties, or because they represent a high loss of energy and/or material contents from economy and society. Subsequently, mixed waste streams and different product groups can be assessed by analysing their specific material composition.

4.1.1 System boundaries

Waste generation and waste management lead to several types of environmental impacts, but the impacts related to waste can also be found in upstream life cycle stages, for instance, if a waste treatment option results in a reduction of the use of virgin material and energy. In the life cycle of a material, from the extraction of resources, through the product manufacturing processes, until the release into the environment from waste treatment, there are a number of exchanges between the life cycle system and its surroundings. For instance, energy is generated during incineration, and the benefit of this energy depends on whether this energy is recovered or not, and if recovered, on the type of (marginal) energy it substitutes in the surrounding system: Is hydropower the energy source substituted, or is it power from coal, oil or natural gas combustion, or is it electricity generated by renewable energy sources?

These examples show that the environmental impacts from the life cycle of a material not only include accounting for emissions or energy consumption, but also for the interactions with the surrounding systems, such as energy substitution, plant capacity substitution, or raw material substitution due to secondary raw material generation.

The relevance of these interactions with the surrounding system does not come to light by only analysing one single material in one single life cycle chain. Such an analysis would only help to identify the stages in the life cycle of the material where the interactions with the environment are produced. The relevance of these interactions is typically detected when comparing two or more material life cycles or two or more treatment options for the same material.

Having said this, the dependency of life cycle results on the surrounding system does not exclude that some of the conclusions can also be valid at national and supranational levels. If e.g. life cycle studies from different geographical and technological conditions arrive at similar conclusions, then it is possible to generalise these, and use them for EU policy support.

4.2 Construction of the LCA-based material and energy resource indicators

The methodology is based on a bottom-up approach, meaning that data are collected from specific materials and treatment processes, and aggregated into overall impact results. The necessary data for the study are e.g. emissions, energy and material consumption, and waste material mass balances. These data are frequently technology and material-specific. While numerous data sets can be obtained from LCA databases, some additional specific data has to be collected individually.

The chosen methodology is based on a process LCA approach, that is, a bottom-up approach. Even though top-down approaches based on input-output tables and NAMEAs³ have been previously tested for prioritisation of resources (see e.g. Moll et al., 2003), such approaches do not have currently in Europe⁴ the precision level for describing the waste treatment technologies and prevention actions required in this study, in many cases addressing directly materials, products and services.

The materials to be covered by the modelling are the following:

- Aluminium
- Cardboard
- Paper
- Glass
- Iron and steel
- Mineral materials (e.g. cement)
- Organic material (e.g. food waste)
- Plastic (PE, PET, PP, PS and PVC)
- Textiles (synthetic and cotton)
- Wood
- Oil

According to Moll et al (2003), Van der voet et al (2003) and Dall et al (2003a and 2003b), these materials are believed to cover most environmental impacts in all waste materials, except toxicity.

The material specific approach has been chosen, as it is difficult (if not impossible) to give a true and fair view of the environmental impact potentials of mixed waste fractions such as total municipal solid waste or manufacturing wastes, unless these aggregated waste streams are split up into components/materials. These basic materials are therefore the basic 'building blocks' of the waste streams.

The first step in the calculation of the indicators has been to make a mass and energy balance of the life cycle of each of the waste materials studied. It also has to be established what the substitutes are for the produced energy from incineration and the recycled materials.

The life cycle perspective implies that aspects from cradle to grave are considered. As waste, materials can either be landfilled, incinerated or recycled⁵. What is more, both the incineration and recycling processes have outputs to landfill (e.g. ashes, slag, recycling rejects) and potential energy and material exchanges among themselves. If waste materials are incinerated or recycled, they can generate energy or materials.

All these variables need to be defined for being able to calculate the impact of prevention. The information or data needed for evaluating these avoided categories are material-specific and require quantifying the total amounts ending up as waste and how they are distributed through the waste management system.

³ NAMEA: National Accounting Matrix including Environmental Accounts.

⁴ In Japan and the USA, input-output tables have a high definition and would allow their use in a study like the present one.

⁵ The term recycling is interpreted broadly and encompasses operations such as composting, mechanical sorting, and anaerobic digestion.

4.2.1 Quantification of pressures and definition of scenarios

For a quantification of the potential environmental benefits and drawbacks of a given material it is necessary to set up one or more scenarios that define the waste material management system. This makes it possible to compare scenarios, and thereby the different waste material treatment options with each other. The first step in ensuring the comparability of the scenarios is the definition of a 'Functional Unit' (FU), which describes the function to be covered by the scenarios.

4.2.1.1 Functional Unit

In the present study, the functional unit is *'A scenario for the use of 1 kg of a given material, including the upstream processes of production of the material, and the downstream processes of waste treatment, including recycling'*.

The term 'use' means utilisation by a final user, be it a consumer or a company where the material exits as waste and not as part of the company's product.

The term 'material' in the functional unit refers to the same mass of a material, which goes through its life following in the different life cycle phases:

- In upstream processes a material is e.g. 1 kg of plastic granulates, 1kg of steel, 1 kg of paper sheet, where the properties of the material are not further altered in the chain, just its form or shape may be changed to fit into a product.
- In the use phase, the term refers to products or services containing 1kg of a given material (e.g. a number of plastic coffee mugs containing in all 1 kg of PET) that is used, and in some cases reused.
- In the disposal phase, 1kg of the material is now considered waste and is treated through recycling, incineration or land filling.

Using the three waste management options of land filling, recycling and incineration as the point of departure, three scenarios for waste management are defined.

4.2.1.2 The use phase

The two most relevant impact areas from the use phase are energy consumption and uses involving ancillary chemicals such as pesticides or cleaning agents.

The environmental aspects related to the use of energy and reductions in the use of energy are covered by energy use prevention policies, rather than waste prevention policies. This part is therefore excluded from the present study.

The major use phase impact covered in this study is therefore the use of chemicals, and the prevention actions that may deal with this life cycle phase.

4.2.1.3 Scenarios

Table 4.2 describes the base set of scenarios that will be elaborated for each of the materials/streams.

Table 4.2: Base set of scenarios

	Scenario	Description
Production	P1-P2	Production process
Recycling	R1-R3	Recycling process
Incineration	I1	Incineration process without energy recovery
	I2	Incineration process with energy recovery
Landfill	L1	Landfill without gas collection
	L2	Landfill with 20 % gas collection, without energy recovery (flaring)
	L3	Landfill with 20 % gas collection, with energy recovery

For each material, at least one production and recycling scenario is modelled. For the incineration of the materials, two scenarios are specified, as the resulting energy surplus from the incineration process could be recovered.

Production and recycling: Material specific processes have been used. It has been the aim to use processes which can be regarded as reflecting the general picture of production processes for the materials and hence not to use country specific data only valid for a minor part of the materials' production. This also concerns the recycling processes used. It has been the aim to use processes generally applied, thus not only reflecting the recycling structure of one single country.

It should however be noted that due to constraints in resources, in general only one technology level for recycling has been applied for every material. This process is used as a proxy for the general recycling. It is acknowledged that several recycling technologies may exist for each material. It has been chosen to focus on closed loop recycling whenever possible (e.g. recycling of glass into recycled glass) and only to a limited extent apply open loop processes.

Incineration: Material specific processes are used to reflect the specific conditions for incineration of the various materials. Two scenarios have been developed for the incineration of waste materials:

- Incineration without energy recovery (I1)
- Incineration with energy recovery (I2)

It is assumed that incineration plants use a mix of flue gas cleaning systems with wet scrubbers being the most frequently applied (approximately 65 %). The type of flue gas cleaning applied is the same for both scenarios. For more details regarding incineration, please refer to the chapter on waste incineration and energy efficiency below.

Landfill: For the landfill process, three scenarios are elaborated, where the main difference between them is the collection and utilisation of landfill gas. The processes modelled are based on available landfill process models for reactor landfills from BUWAL (SAEFL, 1998b). At the reactor landfill both leaching water and landfill gas can be collected. Collected leachate is led to a processing installation, e.g. public sewage works. Waste received at the landfill is spread out and compressed by landfill compactors. After settling, the surface of the landfill is sealed with a permeable layer of clay and soil.

The generation of methane in the landfill is dependent on several factors and is rather complex to model. In order to ensure consistency with the guideline of the Intergovernmental Panel on Climate Change (IPCC)⁶ the generation of methane from the reactor landfill has been reassessed. Table 4.3 lists the calculated potential methane generation per kg of materials deposited at the landfill. The calculations follow the methodology outlined by the IPCC guideline.

It is estimated that maximum 20 % of the methane generation potential is recovered (ETC/ACC, 2006). This is due to the fact that the formation of methane will start in anaerobic parts of the landfill already while waste is being landfilled, i.e. before the top layer and methane collection system is in place. In addition, cracks and fissures in the landfill layers can entail that the methane collection, once in place, is not 100 % efficient.

⁶ Details at: <http://www.ipcc.ch/pub/guide.htm>

Table 4.3: Methane potential per kg material deposited

	Methane potential [kg/kg]
Aluminium	0
Cardboard	0.067
Paper	0.067
Glass	0
Iron and steel	0
Mineral materials (cement)	0
Organic material (e.g. food waste)	0.050
Plastic (PE, PET, PP, PS and PVC)	0
Textiles (synthetic/cotton)	0/0.133
Wood	0.133

4.2.2 Data

It is necessary to consult a number of different data sources to develop the indicators. The basic data requirement is activity data, that is, data on waste material flow generation, as presented in chapter 3 and appendix 1.

LCA data with mass balances of treatment facilities can often be consulted directly in LCA databases or created on the basis of data found in technical reports, scientific reports, or technology fact sheets. In this study, a large part of the technical data about unit processes for waste treatment is already available in the LCA-database used 'GaBi 4' (see below). The variations in data availability often result in a combination of data sources with varying quality in relation to time scope and data representation. In many cases, assumptions have to be made to fill in data gaps.

The indicators used in this project are meant to provide knowledge about priority waste materials to be used as decision-support in waste prevention policy. The data applied to develop the indicators should therefore reflect the likely changes in the future waste management system, rather than the current status of the system.

Marginal technologies in a waste management system are those technologies that are actually affected by small changes in demand, and are covered in prospective and consequential studies, among others LCAs (Weidema, 2003). Using data on marginal technologies thus gives a better characterisation of the actual consequences of a decision than average technologies.

In relation to waste management processes, the marginal landfill technologies are sanitary landfills complying with the EU Landfill Directive. The marginal incineration technologies are incinerators complying with the air emission standards of the EU Incineration Directive and with heat recovery and combined heat and power production. Similarly, the marginal recycling technologies and emissions thereof are those expected to be in use during the previously mentioned time perspective. Thus, it is modern waste management processes that are considered in this study when modelling the waste management systems.

4.2.3 From data to results

In this section, the basic principle for calculating the indicator values will be presented. Emphasis is put on describing the modelling of the waste material's mass balances with the LCA database, and how its outputs can be converted to aggregated values via normalisation and weighting.

4.2.3.1 The GaBi pc-tool

The LCA tool used in this study is called 'GaBi 4'⁷. It contains a number of databases from BUWAL, AMPE and EDIP and a number of weighting methods. The background for choosing this software is that it can handle the Danish database and impact methodology EDIP, which is proposed for the impact assessment.

The comprehensive task of collecting and processing the input-output data in the waste treatment system is made more operational by the use of GaBi 4. The tool can be used for various purposes, e.g. evaluation of processes or products in a life cycle perspective.

This project primarily uses data from the EDIP database. This is mainly because the predefined processes in EDIP are highly useful in a waste management context. Thus, recycling and incineration processes for a large number of materials are already modelled in the EDIP database and can be used as building blocks when modelling a complete system. Likewise, useful processes on production of primary materials can be found in the EDIP database.

It should be noted that the EDIP database was originally developed for use in Danish industry. This implies that the processes cannot be regarded as being universally applicable for conditions in other countries. This circumstance has to some extent been taken into account by assessing which marginal energy source should be taken into account and integrating this into the processes used. However, for the purpose of this project it has not been possible to investigate detailed local processes in the field of waste management. The processes in the EDIP database have thus been used as approximations of more generic processes.

When the original EDIP database was published in 1996 it contained mainly information dating from the beginning of the 1990s. Since then, the database has been updated on several occasions supplying data sets from 1995 to 2001. One of the more recent updates was performed in 2002/2003. The updates have meant that a number of old processes have been updated and new ones added. Furthermore, a number of previous errors have been corrected. Nevertheless, many of the processes are still based on relatively old data from the early 90s, and these should be taken into account when evaluating the outcome.

An update (service-pack) for GaBi was released in May 2006. The update contains a series of processes which have been essential to the work of this project, for instance data on textiles, and organic materials

4.2.3.2 Normalisation and weighting

Once the waste material treatment system has been modelled, a balance of inputs and outputs from the system can be obtained. There are different kinds of inputs and outputs, e.g. resources, energy and emissions. These exchanges have differing properties, and cannot be compared directly. In order to deal with this issue, various LCA methodologies use the concepts of normalisation and weighting.

⁷ http://www.environmental-expert.com/software/pr_eng/pr_eng.htm#gabi

The outcome of the life cycle assessments are prepared to facilitate a normalisation according to the EDIP methodology. Weighting will not be used for all indicators, primarily because there is no need to aggregate and cross-compare the result among indicators.

The references used in the Danish LCA methodology EDIP for normalisation and weighting are the so-called 'person equivalents' (PE) and 'person reserve' (PR). PE quantifies the average pressure per capita in a given region of the category of interest. PR quantifies the pressure relative to the resource base per capita on a global level (i.e. the scarcity of a resource).

The use of scarcity as normalisation reference for resource use is open for debate. The resource's scarcity is a first approximation of the impact derived from the use of some natural resources. However, the discussion of this issue is beyond the scope of this study. Hence, resource consumption is normalised using the concept of PR from the EDIP methodology, where:

- The person reserves for non-renewable resources are based on the resource's relative scarcity measured in terms of reserves, i.e. known and economically exploitable resource bases.
- For renewable resources are based on the net extraction ratio, i.e. the difference between the extraction of the resource and its regeneration capacity.

4.2.4 Assumptions and delimitations

This section describes some important assumptions of the waste management systems analysed. The assumptions regard how the boundaries of the analysed systems are defined, as well as the interactions (in terms of quantitative data) of the life cycle of material systems with the surroundings.

When investigating the benefits and drawbacks of recycling and incineration compared to land filling, it must be considered how recycling and incineration influence the use of the material studied and its energy content, and how these substitute virgin material and other energy sources.

It should be noted that transport between the different life-cycle phases is not included. Hence, the results relate only to the processes of production and waste management of 1 kg of material/stream.

4.2.4.1 Recycling

The recycling of the materials is modelled using processes that describe the per kg treatment of waste material. In some cases, the recycling implies some sort of pre-treatment of the waste material, whereby some of the material is rejected (e.g. because of lacking quality or impurities). It is pivotal to the recycling processes that the quality of the material to be recycled is sufficient. Hence, it could make a difference whether the material is found in mixed MSW or is collected separately.

In the modelling of the recycling processes it is presumed that the recyclable materials have a sufficient quality to ensure the functioning of the recycling process. Consequently, the results indicate the benefit of the recycling process, but do not necessarily describe the benefit of additional recycling of larger parts of mixed waste streams where materials could be polluted and thus harder to recycle.

4.2.4.2 Material substitution

In a situation where the market for recyclable materials demands more waste materials than what is provided, it can be assumed that the recyclable materials substitute virgin materials of the same type.

In paper recycling, the length of wood fibres decreases for every time a fibre is recycled, resulting in a need of input of virgin fibres to keep up the quality. This issue is called loss of material grade. The quality loss of material grade has been accounted for whenever applicable/feasible.

4.2.4.3 Energy production

The type of energy used in the processes is identified using market based information regarding marginal energy sources. Marginal technology is defined as the technology actually affected by a small change in demand. The more general procedures for identifying marginal technologies can be found in Weidema (2003). Table 4.4 below reproduces the examination of marginal grid electricity in central Europe, in which coal based technology is identified as the marginal technology.

Table 4.4: Grid electricity

<p><i>Market ties:</i> -</p> <p><i>Market segment:</i> Base load</p> <p><i>Geographical market:</i> Central Europe</p> <p><i>Market trend:</i> Increase (Eurostat 1997b, OECD 1997, European Commission 1996)</p> <p><i>Production constraints:</i> Nuclear and hydro based power politically constrained (European Commission 1995b, 1996, 1997a). Co-generating technology limited by the local demand for heat. The installation of co-generation is independent from the choice of technology for the general electricity market. Wind power is currently expanding its market share, but the development is still constrained by the availability of technical knowledge. In most of EU, lignite based power plants are no longer built due to emission quotas, especially the SO₂, NO_x and CO₂ targets. An exception may be Greece, where lignite power plants produce most of the electricity supply without indication of decline (Eurostat 1997a).</p> <p><i>Affected supplier/technology:</i> <u>Coal-based technology</u>. This conclusion is based on the calculation of production costs showing that coal based technology is the cheapest. The production costs are composed of operation and maintenance costs, fuel costs and depreciation and interest on capital goods. Operation and maintenance costs and capital goods are taken from Energistyrelsen (1995) and data on fuel costs are from Larsen (1997). The calculations are made for proven technologies, relevant for new plants. The results are verified with data published by Hammar (1997). Calculations have been made for such technologies only, which may have a potential to be the marginal electricity source following the considerations in the above sections. Due to fluctuation in demand, power plants operate on average at less than full capacity. In the calculations, 50% capacity utilisation is assumed. The efficiencies of the plants are for electricity production only, since co-production of heat is not relevant for a marginal power plant, for reasons stated above.</p> <p>The calculation is most sensitive for the fuel costs, where the gas price may be set too high in the above calculations. Furthermore, due to the lower capital costs required, gas fired plants may also be the preferred technology under periods of high interest rates and insecurity. The current deregulation also favours technologies with low investment costs, as has been seen after the deregulation in the U.K. (DTI 1998). Furthermore gas fired plants better fulfil the requirements of the electricity networks for ability to adjust output quickly on a minute-to-minute basis (Dienhart et al. 1999). Therefore, it could be recommended to apply gas-fired technology in a sensitivity analysis.</p>
--

Source: Weidema (2003)

For the specific purpose in this project it should, however, be noted that some of the processes available in the databases are terminated (e.g. aggregated into one process including all upstream processes). Hence, it is not possible to change the energy source. These processes are often modelled using the grid mix of electricity. Therefore, energy use in processes will to some extent be based a grid mix of electricity.

4.2.4.4 Energy substitution

When incinerating waste with energy recovery, it is of crucial importance for the results which other energy sources are substituted. In this context it is chosen to use market based information to identify the marginal energy source in the period studied.

For energy scenarios of incineration, Danish incineration data have been used, since these have been available in terms of data. Dall et al (2003a) include a survey of Danish incineration plants. In

average incineration plants with energy recovery produces electricity and heat in a relation of 23% electricity and 77% heat. The energy recovery efficiency is estimated to be 75%.

These incineration efficiency factors are important, because they have a high influence on the energy offset that can potentially be achieved by materials with a high calorific value such as plastic, paper or wood.

Both heat and power produced are delivered to public grids, where they substitute power and heat from other sources. However, combined heat and power stations produce also heat in surplus, and therefore the contribution from incinerators will create even more excess heat. In a Danish guideline under publication (Schmidt and Strömberg, 2006), it is recommended to only include the displaced electricity when calculating the benefits of energy recovery. Figure 4.1 below is taken from the guideline and presents the relation between incinerators and power plants.

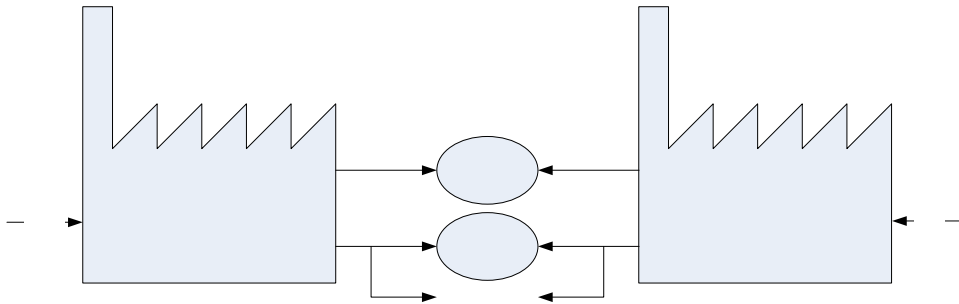

Figure 4.1: Relation between waste incineration with energy recovery and power plants (translated from Schmidt and Strömberg, 2006)

As described above, the marginal technology for power production in Europe is coal-based and as can be deduced from the Figure 4.1, the electricity produced from 1 MJ waste displaces the electricity produced from 0.54 (17/32) MJ coal.

Frees et al. (2005) has included the option that only heat is produced in the incineration. In this case natural gas is displaced. Taking the waste heat into consideration it is estimated that 1 MJ of waste displaces 0.32 MJ natural gas.

These assumptions do not cover cases where decentralised heat/power stations are involved using different types of fuel with differing efficiencies. It is outside the scope of this study to estimate each single option.

4.2.4.5 Waste incineration and energy efficiency

In Table 4.5, the general preconditions for the incineration of waste materials are listed, including energy efficiency.

Table 4.5: General preconditions regarding incineration and energy efficiency

Subject	Precondition	Comments/source
Energy efficiency of incineration	75%	Based on Danish conditions (Dall, 2003a)
Distribution for energy production at incinerators	23 % electricity 77 % heat	Based on Danish conditions (Dall, 2003a)
Flue gas cleaning technology at incinerator	65 % wet 30 % semi-dry 5 % dry 10 % DeNO _x 60 % dioxin removal	Danish average in 2000. Source: From GaBi documentation on incineration processes
Management of slag and ashes from incineration processes	80 % reused/recycled 20 % landfilled (special treatment ⁸)	From GaBi 4 documentation on incineration processes

Though the data are based primarily on Danish experiences the incineration plants represent a wide range of technologies that are also used in the other EU countries.

4.2.4.6 Energy from methane recovery

The methane collected from landfills is assumed to be combusted whereby the recovered energy is used for the production of electricity. The efficiency of this process is set to 33 %. Based on the methane generation potential identified previously, the electricity produced for the different materials is found.

Table 4.6: Energy recovery from landfills per kg of deposited material

	Electricity produced [MJ _{el} /kg]
Paper	0.16
Cardboard	0.16
Textiles (cotton)	0.33
Organic	0.12
Wood	0.33

4.2.5 System description

In this section, the different elements of the waste material treatment scenarios are described. The scenario description helps to understand how the waste systems are modelled and how results are generated. The presentations include the preconditions for the modelled systems, e.g. delimitation and unit processes.

If the reader wishes to further examine the modelled material systems, the PC-tool and its processes should be consulted. If necessary, a data file of the modelling can be obtained from the authors.

4.2.5.1 Paper and cardboard

Paper and cardboard are as far as possible calculated as two separate material fractions. For some processes where no differentiation was available, it has been necessary to use the same processes. This is justified as the properties of the materials are somewhat similar regarding incineration and reuse.

Production: In order to produce paper and cardboard, wood fibres are needed. The sources for these fibres are mainly virgin wood and recycled paper products. A mix of new and recycled fibres makes up many of today's paper products. Nevertheless, virgin fibres are essential in the production

⁸ Landfill designed to handle slags and ashes from incineration processes

of primary paper. Hence, the calculations for primary paper and cardboard are based on the production of 100 % virgin fibres.

Incineration: The recovery of energy depends on the specifications of the incineration plant. In the case of energy recovery, it is estimated that 12.53 MJ per kg of incinerated material can be utilised.

Recycling: When paper is recycled, the cellulose fibres get shorter and thus gradually lose their ability to produce high quality paper. This is the reason why most recycled paper products also incorporate fibres from virgin wood pulp. The shortening of fibres is also called loss of material grade. The recycling process is based on a re-pulping of the waste paper and cardboard where the materials are turned into a mixture called pulp. Subsequently, the pulp undergoes various treatment steps before it is finally ready for transformation into regular paper where the pulp is dried out.

It is assumed that the recycling processes of paper and cardboard produce cardboard material (fluting/liner). It is furthermore assumed that the production of recycled paper and cardboard substitutes primary cardboard production. The loss of material grade is assumed to be 20 %.

Landfill: Paper and cardboard are biodegradable. As a consequence, methane will be formed when these materials are landfilled. In addition, machinery at the landfill site will consume some energy.

4.2.5.2 Plastic (PE, PET, PP, PS and PVC)

In this subsection, plastic materials are considered. As far as possible the materials have been modelled using material specific processes. However, due to lack of data, it has not always been possible to use specific processes for all plastic materials.

Production: Production data for all plastic materials have been modelled. The production data is taken from the EDIP database which mainly is based on data from the European Plastics Industry (AMPE). All production processes are related to the production of primary plastic granulates.

It should be noted that PE consists of both a high density fraction (HDPE) and a low density fraction (LDPE). Dall et al. (2003a) states that the composition of plastic waste in general is 24.7 % LDPE and 16.1 % HDPE. This corresponds to a composition of LDPE and HDPE in the mixed PE waste of approximately 60 % and 40 % respectively. The 40/60 split is used in the calculation of the average PE composition. The distribution corresponds to EU average figures and can be looked up in Table 4.11

Incineration: The energy recovery from plastic is estimated to amount to 14-33.8 MJ per kg depending on the type of plastic. See Table 4.7 for the specific values.

Table 4.7: Energy recovery from incineration of plastics

	Recovery of electricity [MJ/kg]	Recovery of Heat [MJ/kg]	Total energy recovery [MJ/kg]
PE	7.3	24.4	31.7
PET	5.4	18.2	23.6
PP	7.8	26.0	33.8
PS	7.1	23.6	30.7
PVC	3.2	10.8	14.0

Recycling: Data on recycling processes for plastics is scarce. Only data on recycling of PE is obtainable from the databases. Data on PE recycling is based on a process where the plastic waste is re-granulated and thus enters the market for granulate products. It is assumed that the recycling of other plastic materials follows a similar structure. Hence, data for recycling of PE is used as a proxy for recycling of all plastic types.

The applicability for PVC is, however, more uncertain. The achievable quality of the PVC recyclables determines the potential of the mechanical PVC recycling. Even by separate collection of PVC wastes by type it is very difficult to obtain PVC material of an exactly uniform composition which required by recycling (Plinke et al., 2000).

For all plastic types it is assumed that the recyclable granulate will substitute primary plastic production of the corresponding type. The material losses are assumed to be 10% and the quality loss is 0.8 (i.e. 20%) through plastic recycling. The recycling of polyethylene is dependent on the ratio of LDPE and HDPE in the material stream. Here the same split between the two PE types is used as in the production process.

Landfill: Most plastics are not degradable in a short term (<100years). Storage within a landfill will over a longer time horizon may result in some degradation, and as a consequence, methane would be formed. In addition, machinery at the landfill site will consume some energy.

4.2.5.3 Glass

Calculations regarding glass are made on packaging glass material, which is assumed to be representative for the glass content in mixed waste.

Production: The data on production of glass is based on the production data for primary glass without any specific use.

Incineration: Glass has no calorific value and does thus not produce any energy when incinerated. The incineration process of glass requires energy (in the form of thermal energy) since it takes in energy during incineration and releases it when ashes are cooled down.

A default incineration process for glass in the EDIP database has been chosen where the incineration process requires water, power and heat. The processes for these inputs are modelled using energy data on energy production from natural gas.

Recycling: The recycling process is assumed to take place by the recovery of glass cullet into new secondary glass. It is assumed that the new glass substitutes the production of the same amount of primary glass, i.e. no loss of material grade.

Landfill: Glass is not degradable, and consequently no methane will be formed. However, machinery at the landfill site will consume some energy.

4.2.5.4 Aluminium

Production: Two processes for the production of aluminium have been obtained; a standard aluminium production process (designated P1) and a process based on best available technology - BAT (designated P2).

The standard aluminium production data are based on a study of the EAA (European Aluminium Association), which reflects the situation in Europe and include the entity of the European (without the eastern countries). The process data concerns only the Coalescence electrolysis with pre-burnt anodes.

The BAT process represents the, at the moment, best technologies for the primary aluminium production. Thermal energy from natural gas is used (100 %) for the production of aluminium oxide. The primary aluminium production with the electrolysis process is balanced with optimized energy consumption and the reduction of the anode effect for a better process control. The electrical energy, used in this process, is pure hydro power (e.g. Norway and Iceland).

Incineration: Two processes for incineration of aluminium have been included. In general aluminium does not contribute to the incineration process, because of the lacking calorific value. If, however, thin aluminium foils (<0.05 mm) are incinerated, the net calorific value can amount to 34.4 MJ per kg aluminium foils.

Processes for incineration of regular aluminium (designated I1a and I2a) and aluminium foils (designated I1b and I2b) have been included.

Recycling: Data for recycling process of aluminium is based on a European average. The process includes sorting, melting and alloying. The output is aluminium ingot.

Some loss of material will take place due to oxidation during the melting process. The loss of material has been set to 5%. It is assumed that primary and secondary aluminium can be 100% substituted, which means that no loss of material grade is accounted for. This assumption is rather uncertain, as a significant part of the recycled aluminium, due to different alloys with the use of current technology, cannot directly replace primary aluminium. In addition, the pre-treatment process for aluminium scrap implies that approximately 9 % is sorted out. Recycled aluminium is assumed to substitute primary aluminium.

Landfill: Aluminium is not degradable, and consequently no methane will be formed. However, machinery at the landfill site will consume some energy.

4.2.5.5 Iron and steel

Production: The data on production of primary steel is based on EDIP data which relies on information from the International Iron and Steel Institute. The modelled process is an average of five different steel works. The process is based on manufacturing of steel from crude steel, hot and cold rolling of plates dimensioned 0.5 to 4 mm. It should be noted that even if primary steel is used, it will always contain a certain amount of scrap.

Incineration: Steel has no calorific value and does thus not produce any energy when incinerated. The incineration process for steel requires energy (in the form of thermal energy) since it takes in energy during incineration and releases it when ashes are cooled down. It is possible to separate iron from the bottom ash after the incineration process and subsequently recycle parts of this. This has, however, not been accounted for in this project.

Recycling: For the metals included, there is no regular deterioration of the quality. Steel scrap is used as cooling scrap in the manufacturing of primary steel in the BOF-process (basic oxygen furnace process). The process data is based on recycling of iron and steel into hot rolled steel plates (>6 mm). No loss of material grade has been included.

Landfill: Iron and steel is not degradable, and consequently no methane will be formed. However, machinery at the landfill site will consume some energy.

4.2.5.6 Mineral materials (cement)

Production: The production of cement is based on EDIP data, which again is based on a Danish study analysing the concrete trade in Denmark.

Incineration: Data on incineration of mineral materials are taken from the EDIP database.

Recycling: Concrete is assumed to be recycled in an open loop process, where it is used as an aggregate in construction processes. Hence, waste concrete is crushed and reused in place of virgin aggregate. Virgin aggregate includes e.g. crushed stone, gravel, and sand and is used in a variety of construction processes, e.g. construction of roads.

The emissions from processing of one tonne of recycled aggregate (i.e., crushed cement) originate from the use of energy. As with virgin aggregate, the energy consumption of recycled aggregate is calculated using fuel-specific data from USEPA (USEPA, 2003). The use of energy is listed in Table 4.8.

Table 4.8: Energy consumption for production of virgin and recycled aggregate [kJ/kg]

	Virgin aggregate	Recycled aggregate
Coal	0.7	-
Oil	29	-
Natural gas	3.1	-
Diesel	1.4	17
Electricity	12	17
<i>Total</i>	<i>46</i>	<i>34</i>

Based on USEPA (2003)

It should be noted that energy consumption related to transportation is not included. Transportation of construction and demolition waste is very energy intensive. Consequently, this waste type is usually not transported over long distances. In addition, having uneven transport distances for recycled and virgin material can be crucial for the results (i.e. long transport distances for recycled material will favour the use of virgin materials if these are found at a nearer location). Hence, transport has not been included.

Landfill: As mineral materials are inert, no methane is formed when it is landfilled. The will however still be used energy in the landfill process. The process for land filling of glass (which is also inert) has been used to model the impacts for land filling of mineral materials.

4.2.5.7 Organic material

Production: The production of organic material has been modelled using an assumed composition of organic waste in household waste. According to Christensen Ed. (1998), the content of organic material in household waste is approximately 38 %. Of this 6 % is from animal origin and 32 % is from vegetable origin. This corresponds to 16 % animal and 84 % vegetable content of organic waste.

Subsequently, the production of organic material is composed of the following processes:

- Production of potatoes (84 %)
- Production of meat from pigs (16 %)

The processes are taken from the Danish LCA Food Database (Nielsen et al., 2003).

Incineration: There is no specific process in the EDIP database for the incineration of organic material. The process for incineration of organic waste is based on the EDIP process for incineration of cardboard, with an adjustment for the calorific value. It is assumed that the energy recovered from incineration of organic waste amounts to 3.5 MJ/kg.

Recycling: The recycling of organics will be based on both composting and anaerobic digestion. Three scenarios have been elaborated, and are described in Table 4.9 in more detail.

The products of each recycling scenario will substitute corresponding primary materials, e.g. electricity, NPK fertilisers, and organic-substance-providing fertilisers.

Table 4.9: Recycling scenarios applied

Designation	Type	Products (per kg treated organic waste)	Substituted products
R1	Anaerobic digestion	<ul style="list-style-type: none"> • Power: 0.23 MJ • Digested material: ~0.6 kg 	<ul style="list-style-type: none"> • Coal power production • Organic substance (humus) • Fertiliser
R2	Closed reactor composting	<ul style="list-style-type: none"> • Compost: ~0.5 kg 	<ul style="list-style-type: none"> • Organic substance (humus) • Fertiliser
R3	Open composting (e.g. windrows)	<ul style="list-style-type: none"> • Compost: ~0.5 kg 	<ul style="list-style-type: none"> • Organic substance (humus) • Fertiliser

Landfill: Organic waste is biodegradable. As a consequence, methane will be formed when these materials are landfilled. In addition, machinery at the landfill site will consume some energy.

4.2.5.8 Textiles (synthetic and cotton)

Production: The production of synthetic fibres is covered by the data for fibres of polyester and does include all processes back to the extraction of oil. Similarly, the production of cotton includes all processes back to the sowing of cotton plants. This includes watering, use of fertilisers and pesticides, harvest and processing into bales. The process only deals with conventional production of cotton.

Incineration: The energy recovered from incineration of textiles amounts to the following:

- Incineration of polyester is credited 23.6 MJ/kg
- Incineration of cotton is credited 13.5 MJ/kg

Recycling: The recycling of textiles can be performed in several ways. It is estimated that the most common ways of textile recycling is through organisations such as the Salvation Army where used clothes are collected and sold for reuse or used for humanitarian aid purposes. However, experience would suggest that some textiles may be re-used as cloths at home.

In Denmark, the Danish Red Cross estimates that of the 3 500 tonnes of textiles collected for recycling per year, approximately 2/3 are reused as clothing directly while 1/3 is recycled as cloths (Larsen et al., 2000). These fractions will be used as a proxy for the outlet of used textiles in this study. According to Collins & Aumônier (2002), the UK Salvation Army Trading Company assesses that the energy consumption of recycling operations of post consumer clothing constitutes 1.7 kWh of extracted energy per kg of second hand clothing recycled. Assuming this only relates to electricity, this corresponds to a direct electricity consumption of approximately 0.4 kWh per kg textile recycled.

Even though textiles are reused as clothing, wear and tear caused by the previous owner will imply a loss of material grade, i.e. the quality of the piece of clothing is not identical to a new clothing product. Hence, the recycling of textiles will not be able to offset a corresponding amount of primary textile production. It is estimated that the poorest quality of textiles will be used as cloths while better textile qualities will be used as clothing again. Consequently, two different values for the loss of material grade are assessed:

- 75 % loss of material grade for textiles reused for e.g. clothing purposes
- 50 % loss of material grade for textiles recycled into e.g. cloths

It is assumed that recycling of cotton and synthetic based textiles substitute new production of cotton based and synthetic based textiles respectively.

Landfill: Land filling of cotton will result in the formation of methane Even though synthetic textiles are not directly degradable, storage within a landfill will over a long decade of time result in

some deterioration. As a consequence, methane will be formed. No process on synthetic textiles is available in the databases. The process for land filling of PE has been used. In addition, machinery at the landfill site will consume some energy.

4.2.5.9 Wood

Production: The production of wood is modelled using Swedish timber as an example. The process includes lumbering, shortening and transport of soft wood in the forest.

Incineration: The incineration of wood is modelled using a value of 14.1 MJ/kg for the recovery of energy.

Recycling: The recycling of wood is modelled using data on pre-treatment of wood for the use in the chip board industry. The main environmental pressure in this regard is the consumption of electricity in the pre-treatment process. A value of 0.14 MJ/kg is applied for this process. The recycling of wood substitutes, harvesting of virgin wood, and processing in chip board industry.

Landfill: No process for land filling of wood is available in the databases. According to IPCC guidelines, the fraction of degradable organic carbon (DOC) is 0.4. This value is twice as high as the corresponding value for paper (REF). Consequently, the process for landfilling of paper has been used in the modelling taking into account that the potential methane formation from wood is twice as high as for paper.

4.3 Results at material level

Results from the LCA analysis on the materials level is covered in the following dealing energy and resource indicators as well as hazardousness indicators.

4.3.1 Energy and resource indicators

The objective of this LCA generated resource indicator analysis was twofold: on the one hand, to provide a database of material LCA-based information to be used in the case studies presented later in this report, on the other hand, to identify waste materials with a high contribution to environmental impacts in their lifetimes.

An excel file is enclosed to this report including the results of all calculations. Figure 4.2 and Figure 4.3 in the following depict the results graphically.

The unit of the y-axis in Figure 4.2 is mPR (milli Person Reserves), which implies that the consumption of resources has been weighted according to the resource base per person (worldwide). Hence, a high value in the figure corresponds to a high degree of resource consumption. The x-axis presents the basis scenarios for each material. Please refer to section 4.3.1.2 for details on the scenario abbreviations. This also applies to Figure 4.3.

With the large amount of assumptions needed, and documented in previous sections, it is the order of magnitude and relative values between materials that is the most interesting. Even though calculations have been made as thorough as possible, one should not pay the largest attention to the specific values.

Figure 4.2: Resource consumption per kg material (mPR)

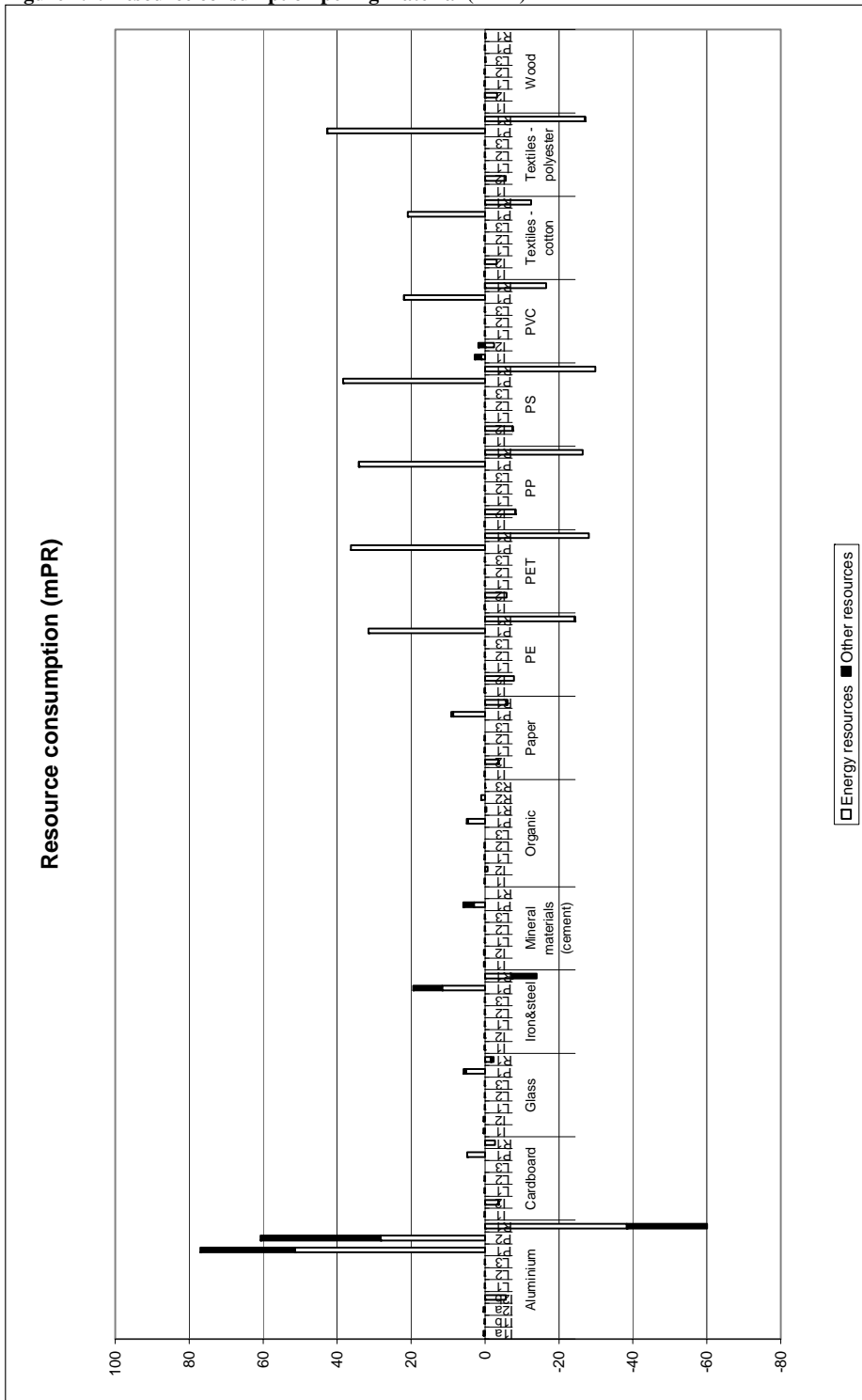
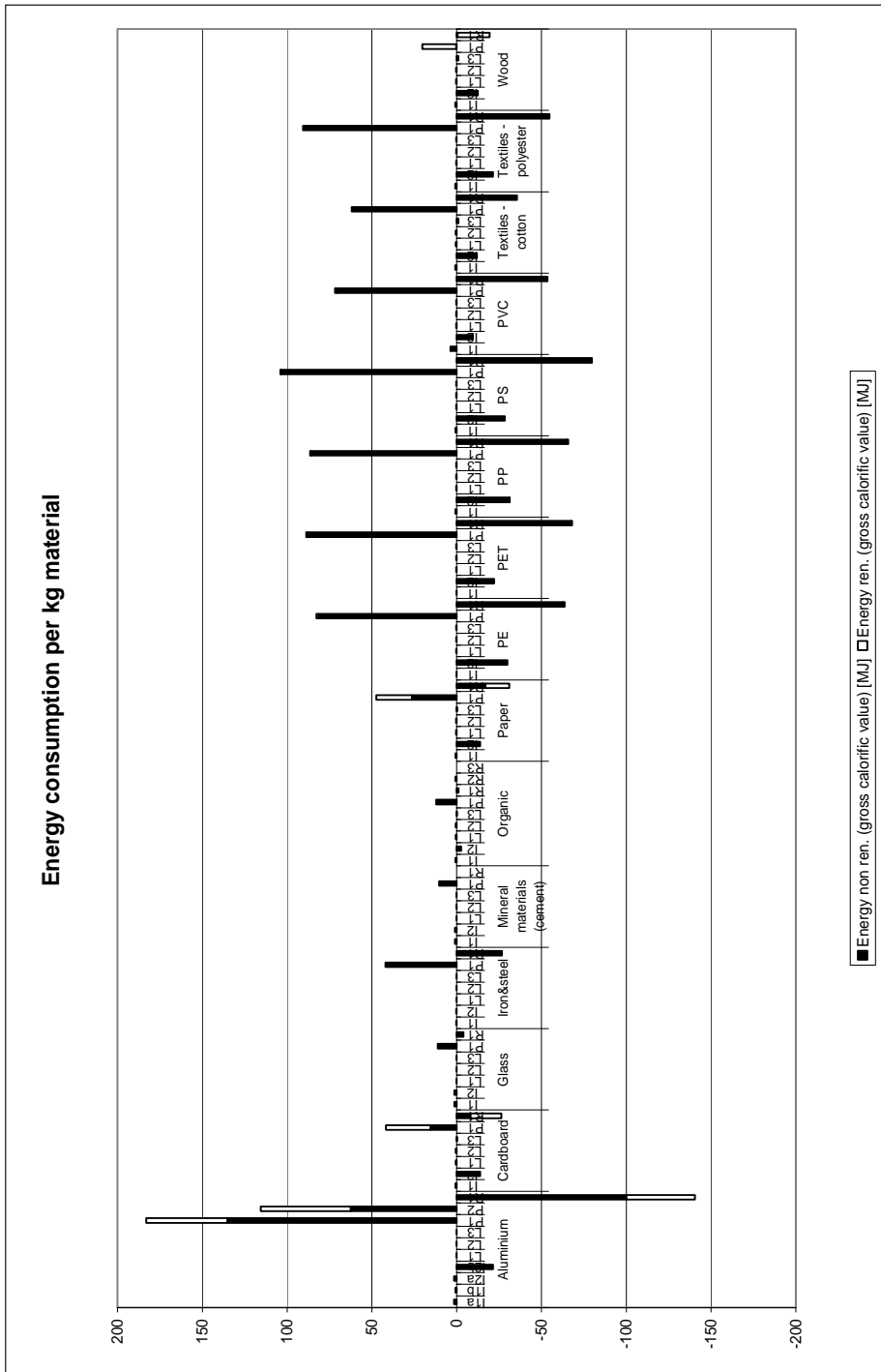

Figure 4.3: Energy consumption per kg material (MJ)



The figures indicate that the production stages for the materials (P1,P2) are the most significant regarding net impacts (i.e. positive values) of resource and energy use. Recycling (R1,R2,R3), Incineration (I1,I2) and land filling (L1,L2,L3) may also have net impacts in some materials, but their order of magnitude is much lower than that of production. The waste treatment processes, however, counterbalance in some materials these impacts if the materials can be recycled or incinerated, since this often implies significant savings. This is especially the case for materials which undergo closed loop recycling, e.g. recycling of aluminium scrap into secondary aluminium.

Please note that the relatively high energy consumption of plastics is partly related to the fact that the primary raw material used is crude oil. It is estimated that approximately half of the value of the 'energy consumption' indicator is attributable to the consumption of oil as a production material, as can be identified in Figure 4.2.

The figures illustrate that the materials have quite different intensity of energy and resource use and different potentials for savings through recycling and incineration. Three groups can be distinguished:

- The first one comprises aluminium and plastics. These materials are very materials and energy intensive, and have also high recycling potentials through recycling and/or incineration. If the energy resources are excluded, then steel has to be incorporated to this 'high intensity' category.
- The next group is composed of cardboard, paper and steel, with medium intensities of energy and resource consumption, and saving potentials.
- The last group comprises wood, organic matter, glass, and construction mineral materials.

4.3.2 Hazardousness indicator

As explained in chapter 2, the hazardousness indicator is constructed as a qualitative scoring method. This was the only approach realistically managed in the frame of this project.

A set of criteria for low, medium and high scores has been applied, representing each waste stream's hazardousness type environmental pressure in the different waste management modes, when low quality (polluting) and high quality (cleaner) technologies/techniques were applied, for three environmental media: air, soil, and water. Total waste stream volumes are included, since they are a necessary element to derive an indicator of the total environmental pressure potential.

Table 4.10 and Table 4.11 in the following present the hazardousness scores. Using the available info in the score tables, scores have been assigned to each main waste stream, in the affected environmental media of air, water and soil, according to the various waste management modes of the waste streams, when *low-tech* (lower case) and *HIGH TECH* (higher case) are involved.

For example, when scoring the energy production waste stream (7th and 8th row in Table 4.10), the typical waste products of this sector was considered, excluding resource mining (since it is a separately recorded waste stream), from the generation of energy in power plants to the treatment of the various residues. Specific hazardous wastes (i.e., solvents, paints, oils, additives, filtering residues, etc.) have also been excluded, because those are separately recorded. Waste generated by nuclear power plants has not been included in this assessment either, because the data recorded on the energy production waste stream does not contain it. The typical 'normal' wastes of concern arising here, in substantial quantities, include fly and bottom ashes, and slag from fossil fuel combustion.

First, specific substances of concern were identified. The major substances of concern are toxic heavy metals that are always present in the geologic media, and in all fossil resources. These get

enriched in the residues. European countries have different approaches towards the treatment and/or utilization of these residues, some store them in piles with poor leachate control, while others promote safe storage and utilisation in building materials.

When recycling with low tech, ashes and slag into building materials (e.g., substituting cement), road (asphalt) and railway (base) construction, the situation is: large quantities, broadly spread spatial distribution; pathways through e.g., leaching into ground/soil and groundwater, potentially reaching the food chain at some point in time. The aggregated score here was medium to air and high to water and to soil hazardousness – not as serious as in the case of known toxic substances surely entering the air, but much more serious than completely inert and non-toxic substances being well contained.

When recycling with high tech, the situation changes. Quality cementation and other binding processes (e.g., vitrification) well encapsulate the residues, and the concerning toxic substances with them. Therefore the created product becomes more inert, with far less potential to harm environmental systems. Therefore our aggregated scores here became low hazardousness (in capital case).

Incineration is not applicable for these wastes. Land filling them, however, poses relative risks on a rather long time horizon for all environmental media, high quality landfills presenting only a minor relief for perhaps a few decades – the large waste volumes with toxic components remaining a burden to be addressed in the future.

Similarly, when scoring the WEEE waste stream (17th row), the typical wastes arising include various metals, plastics, glass and organic solvents (e.g. in flat screens). Some of these, like lead, mercury, cadmium, etc., are known toxins, and so can harm chlorine-based polymers if not correctly treated. When applying low tech for recycling, e.g., no containment, workshops without correct occupational health & safety procedures, braking, tearing, melting - instead of safe disassembling the various parts of the products, the toxic substances escape to air, water and soil.

The score given here was medium hazardousness. In case of high tech WEEE disassembling, the concerns mostly disappear, and the relative risk to environmental media is assumed low.

Incineration of WEEE seems a rather poor option, releasing the toxic substances, mainly heavy metals, and creating new ones in the form of e.g., dioxins and furans, via incinerating chlorine based plastics and organic solvents, together with metals, which are catalyzing this process. Substantial amounts of metals, including the heavy metals, become part of the slag. In low-tech incineration some of these substances escape into the air, and water; while in high tech incineration it is assumed that these substances are captured and sent to controlled landfills.

Storing WEEE in safe landfills might not pose an immediate danger, however, due to the availability of larger volumes of toxic substances on a long time horizon remains a concern. Thus the score assumed here is medium harmfulness. When the landfill is low tech, leaching becomes an actual risk. This brings a high hazardousness score. Due to the relatively stable physical composition of electrical and electronic products and their parts, air pollution does not seem to pose an immediate and high risk, unless uncontrolled, low temperature burning on the low tech landfills.

When all the scores have been assigned to all waste streams on all environmental media for each main waste treatment option, a cross checking has been undertaken, and some of the comparatively unfit scores have been readjusted.

In Table 4.10 the hazardousness scoring results are shown for the main waste streams, on which data has been collected, while in Table 4.11 for the materials, on which the LCA-based resource

and energy indicator (preliminary) is based. In the material-based approach much lower hazardousness rates have arisen than in the waste-stream based approach.

Using these results is thought to be simple, where scores are HIGH and where larger quantities are involved. Those waste streams require priority for further analyses and potential prevention policy. The concerning cells have been highlighted with red colour in the assessment tables.

Table 4.10: Hazardousness scores of major waste streams studied for input to prevention policy and innovation policy analyses

Waste stream	Quantity (M ton)	Recycling			Incineration with energy recovery			Landfill		
		Air	Water	Soil	Air	Water	Soil	Air	Water	Soil
TOTAL municipal solid waste	242.9	Med/LOW	Med/LOW	Med/LOW	High/LOW	High/MED	High/MED	Med/LOW	High/MED	High/MED
TOTAL manufacturing	381.6	Med/LOW	Med/LOW	Med/LOW	High/MED	High/MED	High/MED	High/LOW	High/ME	High/ME
Textile and Leather	8.23	Low/LOW	Low/LOW	Med/LOW	Med/LOW	Low/LOW	Low/LOW	Low/LOW	Med/LOW	Med/LOW
Textile and Leather HZW	0.21	Med/MED	Med/MED	Med/MED	High/MED	High/MED	High/MED	Med/LOW	High/MED	High/MED
Construction and demolition	459.4	Med/LOW	Low/LOW	Low/LOW	Med/LOW	Low/LOW	Low/LOW	Low/LOW	Med/LOW	Med/LOW
Mining and quarrying	376.3	n.a.	n.a.	n.a.	n.a.	n.a.	n.a.	Med/LOW	High/MED	High/MED
Energy production	92.1	Med/LOW	High/LOW	High/LOW	n.a.	n.a.	n.a.	Med/MED	Med/MED	Med/MED
Energy production HZW	0.68	High/LOW	High/MED	High/LOW	High/LOW	Med/MED	Med/MED	High/MED	High/MED	High/MED
Waste from Agriculture	602.6	Low/LOW	Low/LOW	Low/LOW	Low/LOW	Low/LOW	Low/LOW	Med/LOW	Med/LOW	Med/LOW
HZW from Agriculture	0.14	High/MED	High/MED	High/MED	High/MED	Med/MED	Med/MED	High/LOW	High/MED	High/MED
Waste oil	3.52	Low/LOW	Med/LOW	Med/LOW	Low/LOW	Low/LOW	Low/LOW	Low/LOW	Med/LOW	Med/LOW
Sewage sludge	12.59	Med/LOW	High/LOW	High/LOW	Med/LOW	Low/LOW	Low/LOW	Med/MED	Med/MED	Med/MED
TOTAL Hazardous waste	58.16	High/MED	High/MED	High/MED	High/MED	High/MED	High/MED	High/MED	High/MED	High/MED
Packaging waste	25.6	Med/LOW	Med/LOW	Low/LOW	Med/LOW	Low/LOW	Low/LOW	Low/LOW	Med/LOW	Med/LOW
PVC total	4.1	Med/LOW	Med/LOW	Low/LOW	High/Med	Med/MED	Med/MED	Low/LOW	Med/LOW	Med/LOW
End-of-life vehicles	8-9	Med/LOW	Med/LOW	Med/LOW	High/n.a.	High/n.a.	High/n.a.	Med/MED	High/MED	High/MED
WEEE	9-10	Med/LOW	Med/LOW	Med/LOW	High/MED	High/MED	High/MED	Med/MED	High/MED	High/MED

NOTE (*): lower-case equals to low-tech and higher-case equals to HIGH TECH n.a. refers to "not applicable".

Table 4.11: Hazardousness scores of material streams studied for resource impact

Material stream	Recycling				Incineration with energy recovery				Landfill			
	Air	Water	Soil		Air	Water	Soil		Air	Water	Soil	
Paper and cardboard	Low/LOW	Med/LOW	Low/LOW		Low/LOW	Low/LOW	Low/LOW		Low/LOW	Low/LOW	Low/LOW	
Plastics (PE, PET, PP, PS and PVC)	Med/LOW	Med/LOW	Low/LOW		High/Med	Med/MED	Med/MED		Low/LOW	Med/LOW	Med/LOW	
Glass	Med/LOW	Low/LOW	Low/LOW		Low/LOW	Low/LOW	Low/LOW		Low/LOW	Low/LOW	Low/LOW	
Aluminium	Med/LOW	Med/LOW	Med/LOW		High/MED	Med/MED	Med/MED		Low/LOW	Low/LOW	Low/LOW	
Iron & steel	Med/LOW	Med/LOW	Med/LOW		High/n.a.	High/n.a.	High/n.a.		Low/LOW	Low/LOW	Low/LOW	
Minerals (cement)	Med/LOW	Med/LOW	Med/LOW		n.a.	n.a.	n.a.		Med/LOW	Med/LOW	Med/LOW	
Organic materials	Low/LOW	Low/LOW	Low/LOW		Low/LOW	Low/LOW	Low/LOW		Med/MED	Low/LOW	Low/LOW	
Textiles (synthetic and cotton)	Med/LOW	Med/LOW	Low/LOW		Med/LOW	Low/LOW	Low/LOW		Low/LOW	Low/LOW	Low/LOW	
Wood	Med/LOW	Low/LOW	Low/LOW		Med/LOW	Low/LOW	Low/LOW		Low/LOW	Low/LOW	Low/LOW	

NOTE (*): lower-case equals to low-tech and higher-case equals to HIGH TECH . n.a. refers to "not applicable"

4.4 Aggregation impact of waste streams

Suggesting priority waste streams for strategic prevention policy depends on the ranks generated through a series of steps. First, the hazardousness indicator scores need to be combined with the resource indicator data.

Based on the outcome of the resource and energy indicators of Figure 4.2 and Figure 4.3, the hazardousness assessment, and on the total amounts of waste generated, a list of prioritisation, ranking the waste flows and materials has been provided in Table 4.12.

Table 4.12: Proposed ranking of materials

Ranking	Material	Impact on resource indicator	Impact on energy indicator	Impact on hazardousness indicator*	Quantities in the EU
1	Aluminium	High	High	Low/LOW to High/MEDIUM	Medium
2	Plastics	Medium	Medium	Low/LOW to High/MEDIUM	Medium
3	Iron	Medium	Medium	Low/LOW to High/n.a.	Medium
4	Paper	Low	Medium	Low/LOW to Medium/LOW	High
5	Cardboard	Low	Medium	Low/LOW to Medium/LOW	High
6	Organic	Low	Low	Low/LOW to Medium/MEDIUM	High
7	Mineral material	Low	Low	Medium/LOW	High
8	Glass	Low	Low	Low/LOW to Medium/LOW	Medium
9	Textiles (polyester)	Medium	Medium	Low/LOW to Med/LOW	Low
10	Textiles (cotton)	Medium	Medium	Low/LOW to Medium/LOW	Low
11	Wood	Low	Low	Low/LOW to Medium/LOW	Medium

NOTE (*): lower-case equals to low-tech and higher-case equals to HIGH TECH

The prioritisation is based on both quantitative and semi-quantitative data. Hence, it is not possible to assign each material with one single score for a simple ranking as no common denominator is available. In the table above it has been chosen to describe all indicators qualitatively (range: low to high).

The ranking of the materials is found to be sensitive towards the type of waste management which is applied. Subsequently, if all aluminium was recycled, it would not rank as high as the above table implies.

Altogether, caution should be taken when interpreting the results. The listing of materials should only be regarded as a rule of thumb, guiding the work of prioritisation of materials in the rest of the study, as local or regional conditions may have effects that alter the ranking.

The next question to be addressed is: How can this prioritisation based on environmental indicators be tackled through prevention? The two basic types of prevention are qualitative and quantitative (OECD, 2000). Quantitative prevention actions should preferably affect the materials which rank high in the priority list because of their amounts in Europe: mainly minerals, cardboard, paper and organic materials. Such prevention actions affect the energy use and the resource use associated to

the use of these materials. Some of them cannot be prevented, e.g. the amount of food cannot be reduced without resulting in hunger, so prevention has only meaning when the same service can actually be provided by no-use, or by substitution with another product or material. Qualitative prevention actions should focus on materials which rank high because of their hazardousness concerns: mainly aluminium, iron and plastics. The materials list used here is restricted to 11 materials, but in this category, chemicals with toxicity impacts such as pesticides, herbicides, detergents, organic solvents, as well as heavy metals would be candidates to material substitution, had they been included. Quantitative prevention in the materials should focus on the substitution of the additives which result in hazardousness during use, disposal or production (e.g. Bisphenol A, flame retardants and softeners in plastics, heavy metals and waste oils in scrap, impurities in aluminium).

The rest of materials studied (glass, wood) are also mainly tackled through quantitative prevention (to reduce the amounts used), since their hazardousness concerns are low.

4.5 Environmental life cycle midpoint indicators

Whereas the previous results looked at the entire waste production and aimed to rank the waste and material flows in terms of their environmental impact using simplified indicators, this section aims to use more impact categories as well as to take its origin in a few selected cases. For each case a more thorough environmental impact assessment is done in a life cycle perspective with the aim of identifying for that case where waste prevention actions would have the largest impacts in terms of environmental improvement.

The case studies described in detail later in chapter 6 illustrate the impact of a range of different factors like the structure of the political instrument and the political institutional context of the actors and actions on the intended waste reduction. A quantitative assessment of the resulting effects of these factors in terms of the waste reduction they imply has turned out not to be possible since the literature on such evaluations is very scarce. Keeping in mind that it is a very complex task to quantitatively predict actual waste reductions resulting from the use of a specific policy instrument or regulatory regimen, the results of the environmental assessment described in this section may be used as additional qualifying information concerning the environmental impacts caused by different waste streams and the relative environmental impacts of the case studies selected.

As described in chapter 2 on the methodology, and in section 4.3, the impact assessment consists of two steps. Firstly, a material-based approach provides the environmental impact potentials of single-material wastes. Secondly, the potential impacts from mixed waste fractions such as municipal solid waste or manufacturing waste is calculated, combining the information on materials from the first step (the basic 'building blocks').

The materials that were used as 'building blocks' are:

- Paper and card board
- Plastics (PE, PP, PS and PVC)
- Glass
- Aluminium
- Iron and steel
- Mineral materials (cement)
- Organic materials (crops)
- Textiles (synthetic and cotton)
- Wood

The (mixed) waste streams of interest are:

- Total municipal solid waste
- Total manufacturing waste
- Textile and leather
- Textile and leather hazardous waste
- Construction and demolition
- Mining and quarrying
- Energy production
- Energy production hazardous waste
- Waste from agriculture
- Hazardous waste from agriculture
- Waste oil
- Sewage sludge
- Total hazardous waste
- Packaging waste

Table 4.13 below presents how the streams and the materials correlate – which are the percentages of the different materials that are found in the mixed waste streams.

Table 4.13: Correlation between waste streams and material fractions in Denmark.

Waste Stream	Aluminium	Plastics/Oil	Plastics					Iron	Paper	Cardboard	Renewable organic mat.	Mineral material	Glass	Textiles (plastics)	Textiles (nat. fibers)	Wood
			PE	PET	PP	PS	PVC									
Total Municipal Solid Waste	0,0013	0,108	0,041	0,0126	0,0216	0,0119	0,0076	0,0429	0,1498	0,0749	0,3654	0,1415	0,0708	0,0116	0,0116	0,0069
Total Manufacturing	0,0003	0,0243						0,0097	0,0337	0,0169	0,0823	0,0319	0,0159	0,0026	0,0026	0,0016
Textile and Leather														0,5	0,5	
Textile and Leather HZW														0,5	0,5	
Construction and demolition	0,0006	0,01	0,0041	0,0007	0,0018	0,0009	0,0012	0,0194	0,0067	0,0033		0,88	0,03			0,05
Mining and quarrying												1				
Energy production waste												1				
Energy production HZW												1				
Waste from Agriculture											1					
HZW from Agriculture											1					
Waste oil		1														
Sewage sludge											1					
Hazardous waste	0,0096	0,4042						0,3107			0,0120	0,2635				
Packaging waste	0,0118		0,08	0,008	0,0231	0,0112	0,03	0,0323	0,0529	0,4644			0,1587	0,0023	0,0023	0,1134

Sources: Dall et al. (2003a) and DEPA (Danish Environmental Protection Agency) (2005).

NOTE: Only in some streams it has been possible to split up plastics into the different plastic types

The composition of waste in the table is based on data from Denmark. It is assumed that this is – in general terms – also representative for Europe, but this is a rather crude assumption.

In the case-studies, waste flows can contain more than just one material flow, e.g. electronics waste is composed of plastics, metals, screen chemicals, etc.

The assumptions and system boundaries for the life-cycle assessments of waste streams given above, also applies to the assessment performed here. All include the production of the material from raw materials using average data. The scenarios are:

- Recycling (generally only one process is applied and focus is on closed loop recycling)
- Incineration – two scenarios are applied – one with energy recovery and one without
- Landfill – three scenarios are applied related to the extent of utilization of evolved gas

4.5.1 Environmental life cycle midpoint indicators

The following graphs encompass the environmental impact categories included in the EDIP 97 methodology (Wenzel et al., 2000). For the different waste management/treatment options, each graph shows the potential contribution to one specific impact category for 1 kg of each of the materials evaluated (taking its extraction, production and waste treatment into account). The values shown are normalised values, i.e. they are given in person equivalents where the potential impact is related to the annual contribution to the specific impact category from the activities of one European person.

A more thorough explanation and data background for the normalisation values are presented in Stranddorf et al. (2005). For the waste categories only normalisation factors related to Denmark were available and no attempt was made to develop new ones for Europe. The scenario labels (e.g. for recycling, incineration and landfill) are explained in table 4.2.

It should be noted that the scenarios do not include transport between the different lifecycle stages. The processes for the production of primary material and waste management have been modelled individually. Hence the values do not reflect the result of a complete LCA. They exclude the use stage of the products in which the materials are used and can be seen as a contraction of the production and waste management stages of an LCA. Furthermore, the calculated indicator values cannot be regarded universal, as local condition, e.g. transportation, can influence the results.

The results presented in the graphs (4.4 - 4.13) can be used to see where the largest environmental savings are possible if waste streams including the different materials are prevented. For example it is clear from the graphs that for all materials, recycling is the option with the lowest potential environmental impact. Waste prevention actions that are directed at regions, at uses or at materials where the materials are landfilled rather than recycled therefore have a larger environmental improvement potential, confirming the main idea in the EU's waste hierarchy.

The text on the x-axis in figures 4.4 to 4.13 presents for each material different scenarios where the first two (from the left) are incineration (I1 and I2) the next three are landfill (L1, L2 and L3) and the last one is recycling (R1). An introduction to the scenarios was given in section 4.2.1.3. For aluminium four different incineration scenarios are calculated and for organic waste three different recycling scenarios are calculated. The unit of the values in the graphs is milli person equivalent, mPE (see section 4.3.1 for an explanation).

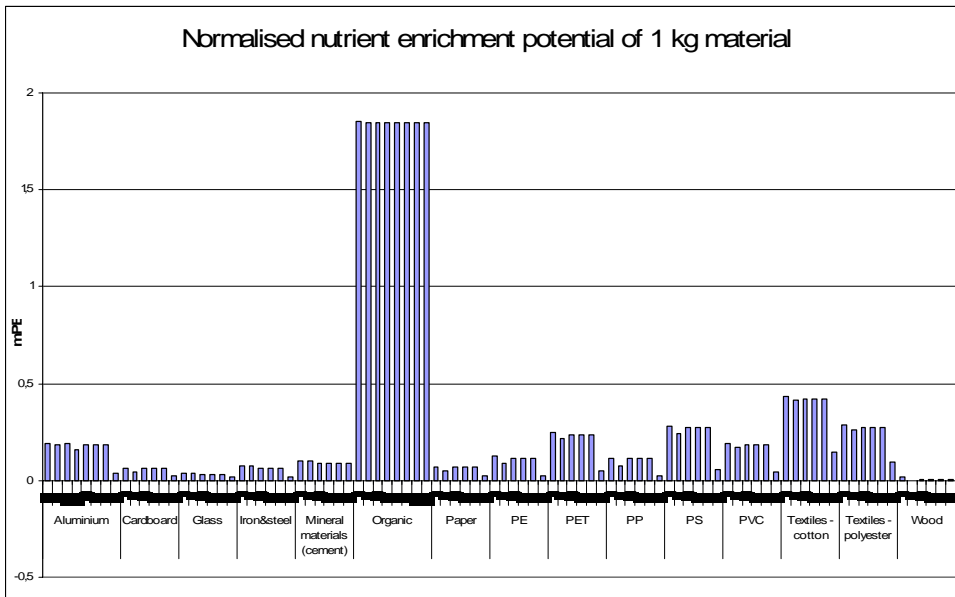

Figure 4.6: The nutrient enrichment potential of 1 kg material.

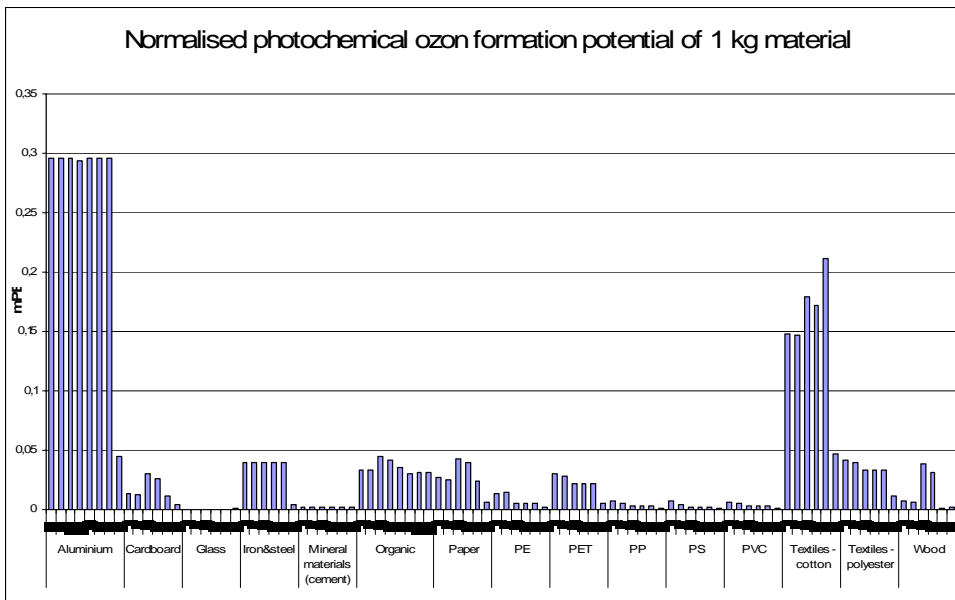

Figure 4.7: the photochemical ozone formation potential of 1 kg material.

Results of the impact potentials will be discussed subsequently.

4.5.1.2 Toxicity impact potentials

The toxicity impact potentials have been presented here separately, since the uncertainties related to toxic impacts are larger than for the other impact categories. The results should therefore be

regarded more as indicative of a trend, than the results for the other (predominantly energy-related) impact categories. The uncertainties are due to primarily three issues.

Firstly there are many different ways to model and characterise the toxic impact potential. Even in risk assessment and threshold limit setting there may be differences in the evaluations performed by regulatory bodies and scientific committees.

Secondly, there are generally larger data gaps concerning toxicity impacts. Partly since monitoring, measuring, and building an inventory of toxic emissions in the supply chain has been shown not always to be adequate; partly because of the lack of data characterising the toxicity of compounds.

Thirdly, there are large uncertainties and omissions in the inventory analysis of specific chemical emissions from the life cycle of the materials, notably from the upstream processes as described in Chapter 2.

In order not to give an over representation of the toxic impacts a modification has been made to the EDIP methodology, which operates with seven categories to describe toxic impacts. There is a distinction between acute and chronic toxicity as well as a distinction whether the exposure pathway is through water, soil or air. These have been aggregated in to two categories: human toxicity and eco-toxicity. The aggregation has been performed through a summation of normalised impacts in each category.

Figures 4.8 and 4.9 present the ecotoxicity and the human toxicity, respectively. Two comments to the graphs on toxicity should be mentioned.

1. Recycling of glass seems to cause emissions of a larger toxicity potential than other handling of glass. For some reason the process for recycling of glass includes an emission of lead that is not included for example in the production of glass. This may be reality for e.g. some types of crystal glass and cathode ray tube monitors but hardly for glass e.g. used for packaging.
2. The process for production of PP has a higher toxicity potential than production of other types of plastic. This is due to an emission of aluminium-ions during production. It is rather uncertain whether this is an artefact.

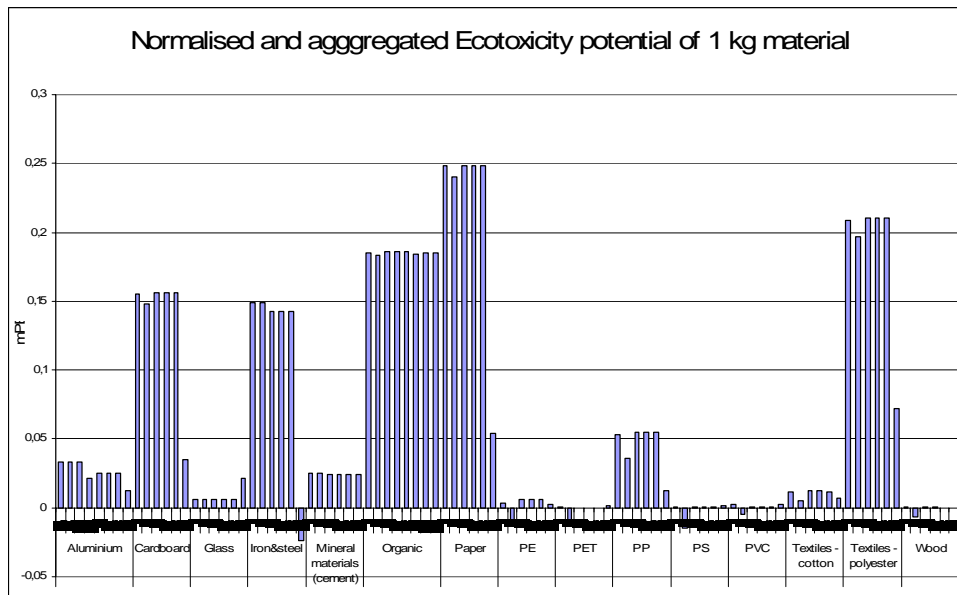

Figure 4.8: The ecotoxicity potential of 1 kg material

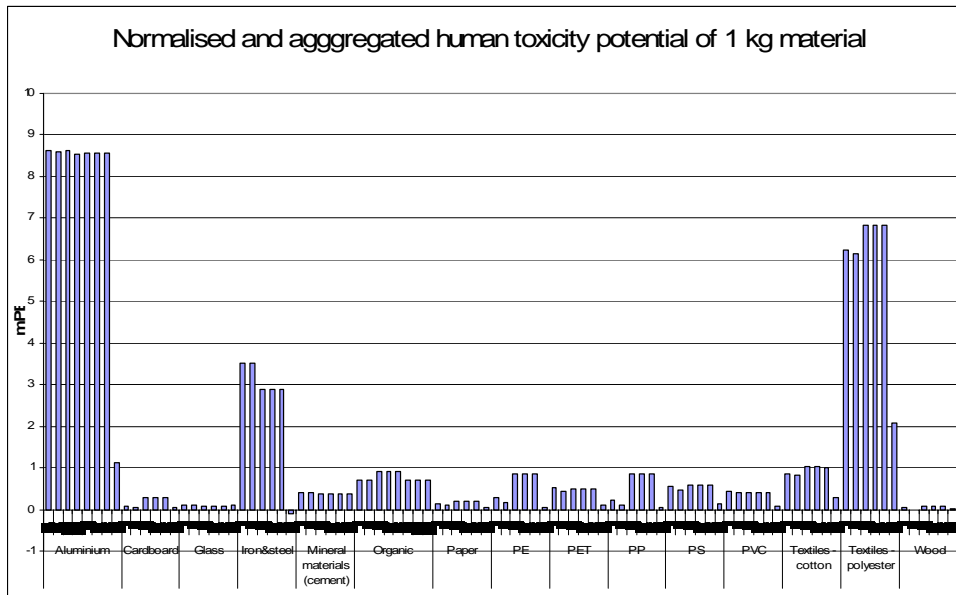

Figure 4.9: The human toxicity potential of 1 kg material.

As seen from the scales of the graphs on toxic impacts the eco-toxicity impacts seems to be comparable with the other impact categories whereas the human toxicity impacts are significantly higher at least for some materials. The human toxicity potential for the materials where it is particularly high is caused by emissions of inorganic materials and heavy metals to air. Whereas this may be justified for aluminium and iron and steel the production of polyester fibres would not be anticipated to produce such high emissions of lead and NO_x, which are the primary contributors.

4.5.1.3 Aggregated impact potentials

Assuming an equal weighting of the different impact categories, the normalised impact potential can be directly summed up to one value representing the environmental impact potential of each scenario. The EDIP methodology involved a weighting based on distance to politically set targets. Weighting factors for the European Union have been developed and they are rather close to 1 for all impact categories. Therefore, the implicit equal weighting by summing the normalised values does not seem distinctly different from such a weighting step. Figure 4.10 shows the summed up normalised environmental impact potential.

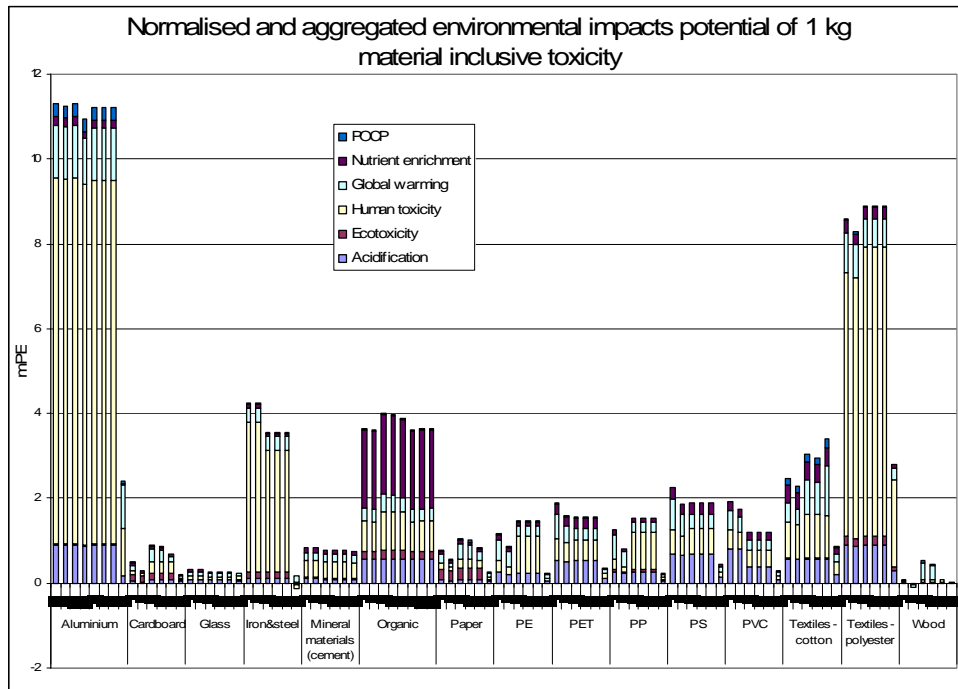

Figure 4.10: Overall impact potentials of 1 kg material.

Considering the uncertainties already mentioned with regards to assessment of toxic impacts and in particular the uncertainties relate to the large contribution to human toxicity in the graph above it is recommended to take origin in the next figure (4.11) which shows the summed up normalised environmental impact potential, however not including toxicity.

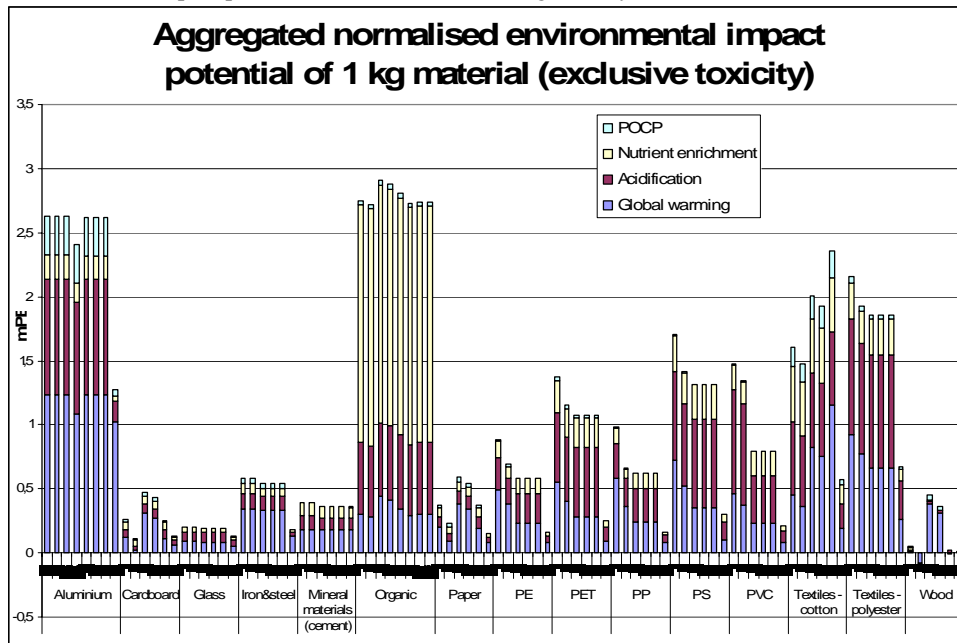

Figure 4.11: Aggregated impact potential excluding toxicity of 1 kg material

4.5.1.4 Resource consumption indicator

The resource consumption indicator presented in figure 4.12 is normalised both according to the global use per person (i.e. in person equivalents) as well as in relation to the scarcity (i.e. how much is used compared to the supply horizon of that resource) and thus provides a picture of the environmental importance of that resource if 1 kg of the specific material is used.

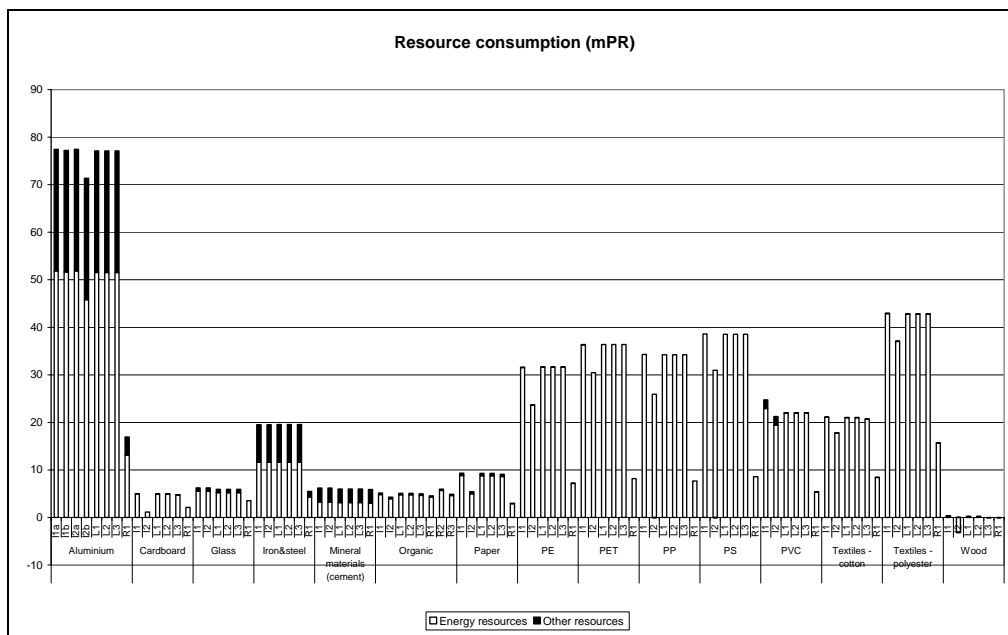

Figure 4.12: Resource consumption for 1 kg material

4.5.1.5 Waste indicator

The waste indicator presented in figure 4.13 is based on the amounts of waste generated for landfills, and it can thus be interpreted as the land use required for each waste management option, assuming a typical landfill height. The considerable high waste factor for PVC from incineration is due to the classification of the residual flue gas cleaning products as hazardous waste, for which the normalisation factor is two orders of magnitude higher than for bulk waste.

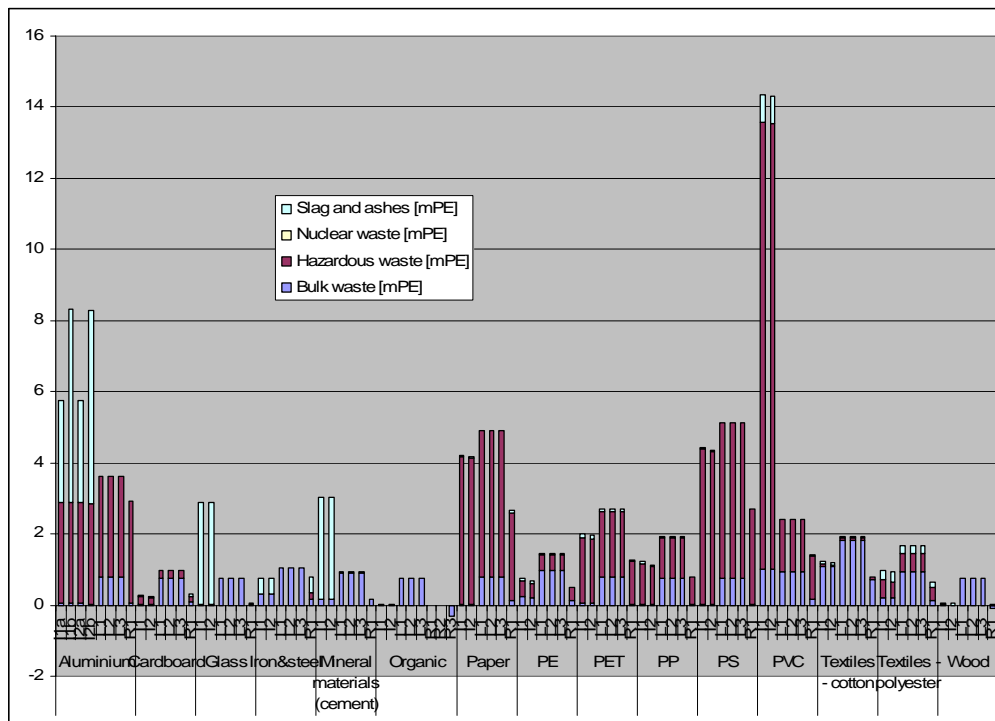

Figure 4.13: Indicators of waste amount for 1 kg material

4.5.1.6 Discussion on the environmental impact assessment of materials

Comparing the environmental impact potential based on midpoint indicators and the simplified resource indicator, generally no big differences are observed in the ranking of waste treatment options of the single materials between the two indicators. One noticeable issue is the high contribution to nutrient enrichment from organic materials. The contribution here is a bit and maybe too high, but reflect the use and leaching of fertilisers from agricultural production.

Also noticeable is that incineration of plastic materials has a higher environmental impact potential than landfill, whereas the loss is equal for resources. The same is true for polyester textiles. This is to some extent counterbalanced in the waste indicator where the landfill option generates more waste. Additionally, the land filling of cotton textile and wood gives rise to the formation of methane contributing to global warming, an issue which is not paralleled in the resource indicator. However the generation of solid waste differs somewhat from the general picture since PVC and paper have larger waste impacts than seen for the other impact categories.

The LCAs performed (both using simplified indicators and midpoint indicators) of the materials streams provides a good example of how the life cycle thinking can be introduced into decisions on where to focus initiatives in waste prevention helping to identify the material streams and waste management system combinations which give the highest potentials for improvement.

4.6 Results at waste stream level

Applying the distribution of materials in the different waste flows presented in table 4.13 the environmental impact profile of each waste flows can be calculated as the shares of each material multiplied with the environmental impact potential of that material and aggregating for each waste flow, applying the principles for normalisation and weighting described and discussed in Section

4.3.3.2. In figure 4.14 the environmental impact potential of one kg waste flows is calculated. Following the same procedure the generation of waste and resource consumption can be calculated as well. The result is shown in figures 4.15 and 4.16, respectively.

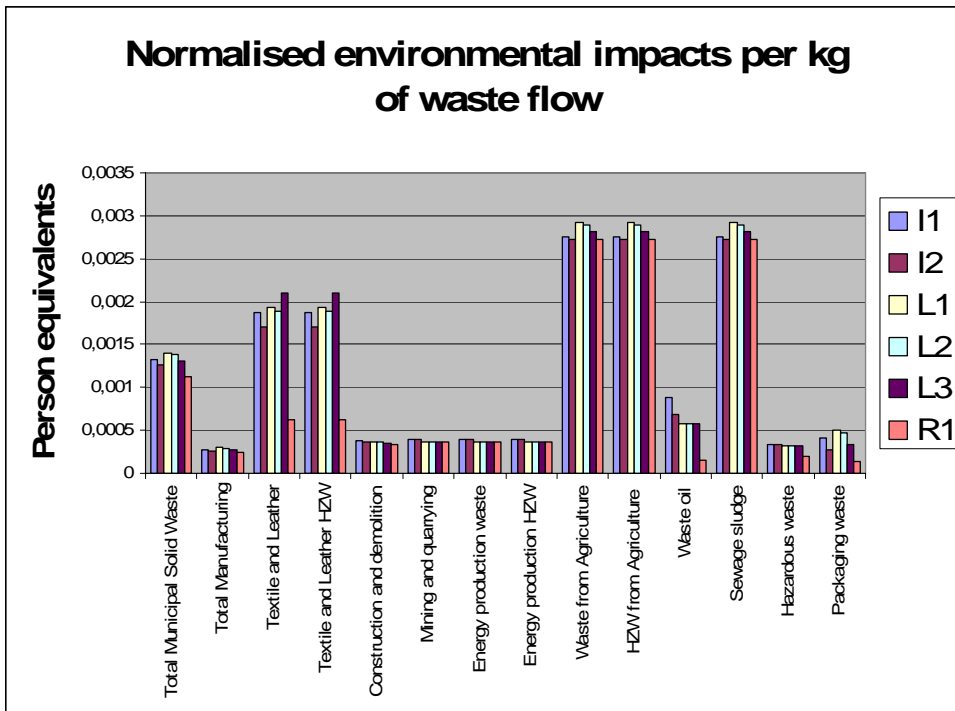

Figure 4.14: The normalised environmental impact of 1 kg of waste flows with a material distribution as presented in table 4.13. Scenarios are explained in Table 4.2 and 4.9. I1-I2 are incineration scenarios (see Table 4.2), L1-L3 are land filling scenarios (see Table 4.2) and R1 is a recycling scenario (see Table 4.9).

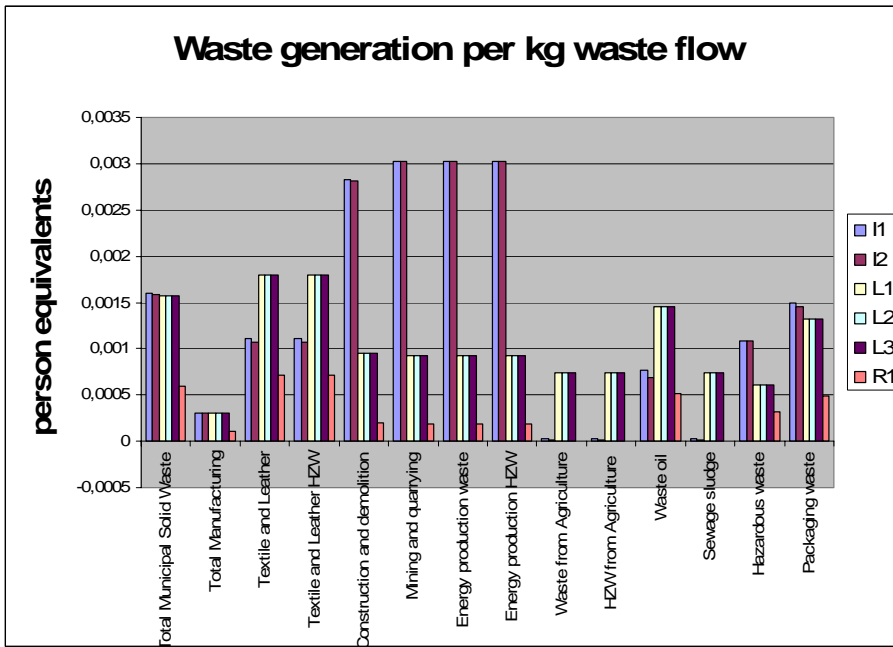

Figure 4.15: The normalised generation of waste from 1 kg of waste flows with a material distribution as presented in table 4.13.

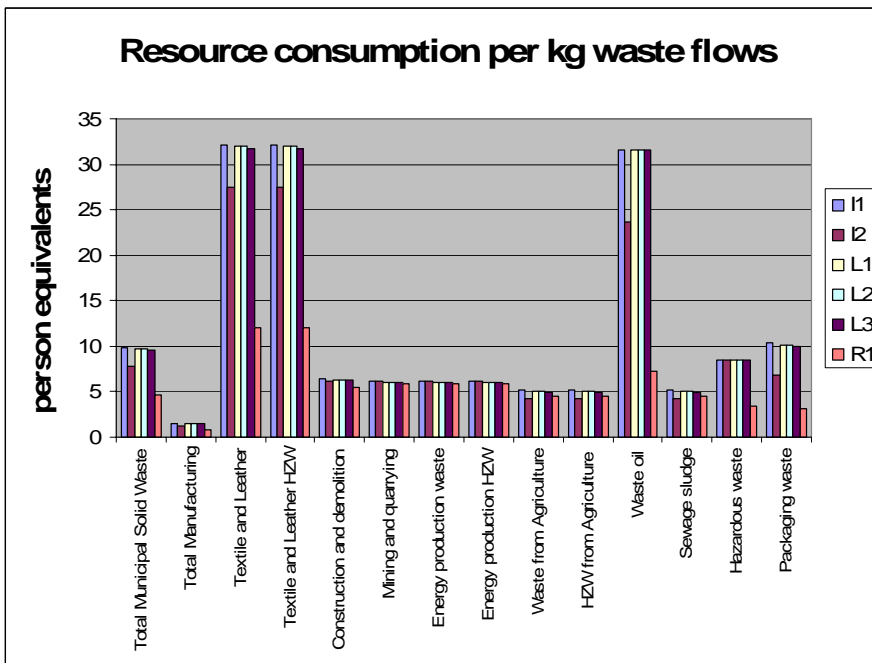

Figure 4.16: The normalised consumption of resources from 1 kg of waste flows with a material distribution as presented in table 4.13.

When relating these results to the results of the hazardousness indicator in table 4.10 it can be concluded that the following waste flows are of particular concern (they contribute to two or more of the graphs above and have high hazardousness indicators):

- Textile and leather HZW (contributes considerably to both environmental impact, waste generation and resource consumption as has a high hazardousness score)
- Total municipal solid waste (contributes considerably to both environmental impact, waste generation and resource consumption as has a high hazardousness score)
- HZW from agriculture (contributes considerably to environmental impact and to some extent to waste generation and resource consumption and has a high hazardousness indicator), and
- Recycling of sewage sludge (Contributes to high environmental impact and resource consumption but not to waste generation, has high hazardousness indicator)
- Waste from energy production and hazardous waste (has high hazardousness indicators and contributes to some extent to the environmental impact, waste generation and resource consumption)

The EU total generation of waste as presented in chapter 3 can be used to calculate the total impact in the European Union of each of the waste flows, still assuming that the distribution of materials in the waste flows can be estimated by the Danish study presented in table 4.13. Figure 4.16, 4.17 and 4.18 shows the environmental impact potential, resource consumption and generation of waste of the total EU waste flows, respectively.

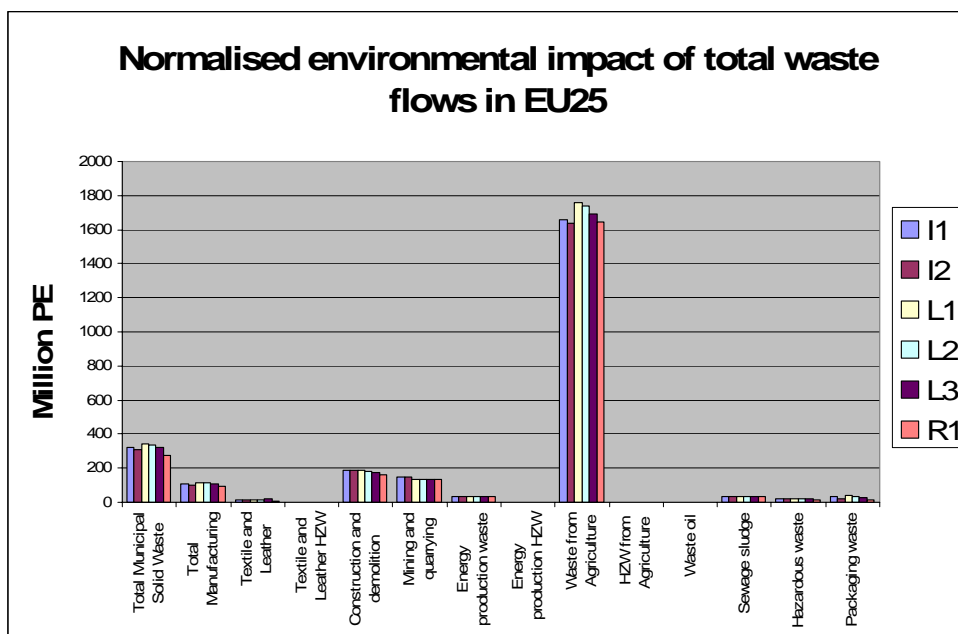

Figure 4.17: The calculated environmental impact potential of the total waste flows in the EU based on the distribution of materials in the waste flows as presented in table 4.13.

The scenarios are explained in Table 4.2 and 4.9 I1-I2 are incineration scenarios (see Table 4.2), L1-L3 are land filling scenarios (see Table 4.2) and R1 is a recycling scenario (see Table 4.9).

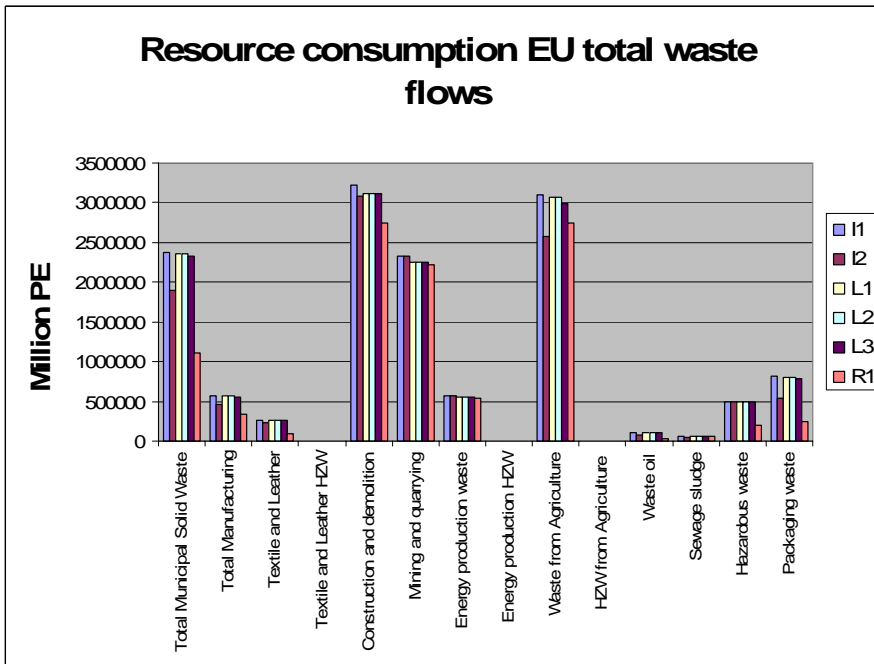

Figure 4.18: The calculated resource consumption of the total waste flows in the EU based on the distribution of materials in the waste flows as presented in table 4.13.

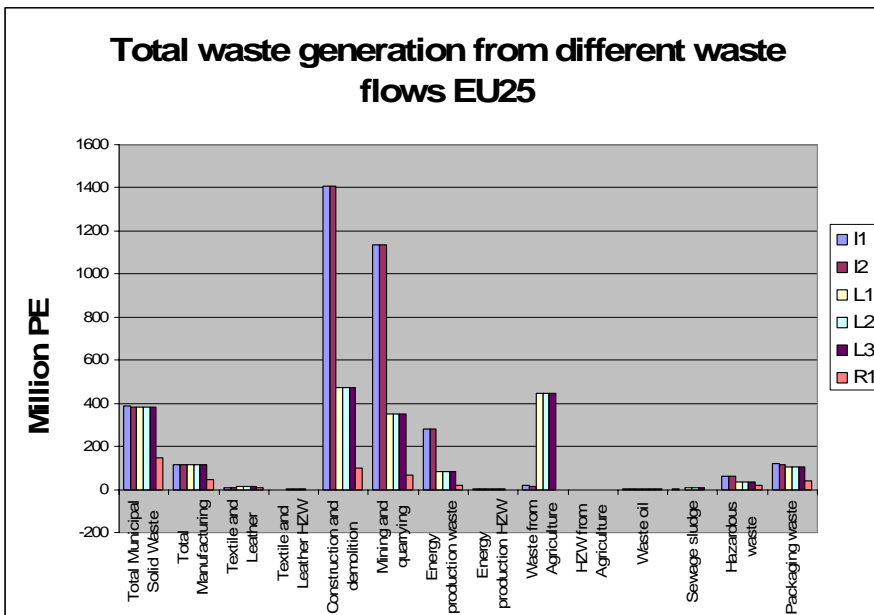

Figure 4.19: The calculated waste generation of the total waste flows in the EU based on the distribution of materials in the waste flows as presented in table 4.13.

From the graphs it is seen that there are five waste streams that contribute to environmental impact, these are total municipal solid waste, total manufacturing waste, construction and demolition waste,

mining and quarry and waste from agriculture. For resource consumptions it is the same waste streams, however additionally including textile and leather, energy production waste, hazardous waste and packaging waste. For the total waste generation it the same waste streams but this time excluding textile and leather. When combining with the hazardousness indicator in table 4.10 the following waste flows is of particular concern when taken the amounts generated in to account:

- Total municipal solid waste (contributes considerably to both environmental impact, waste generation and resource consumption as has a high hazardousness score)
- Total manufacturing waste
- Mining and quarrying
- Energy production waste
- Hazardous waste

4.6.1 Environmental impacts of selected case studies

A range of case studies are selected for the further analysis of policy and innovation. As presented earlier these are:

- Product oriented – waste issues of one specific product (Electronics and vehicles)
- Material oriented – handling one certain problematic material (PVC)
- Waste stream oriented – addressing a type of waste stream from multiple sources (Packaging waste)
- Consumption oriented – when waste appears at the consumer stage (textiles)
- Sector oriented – the waste production of a certain sector (construction and demolition)

For each of these case studies a distribution of materials in each of the waste flows considered has been estimated from chapter 3.2 and an aggregated environmental impact, resource consumption and waste generation has been calculated based on the amounts of waste estimated in chapter 3.2. Figures 4.19, 4.20 and 4.21 shows the environmental impact potential, the resource consumption and the waste generation of the cases, respectively.

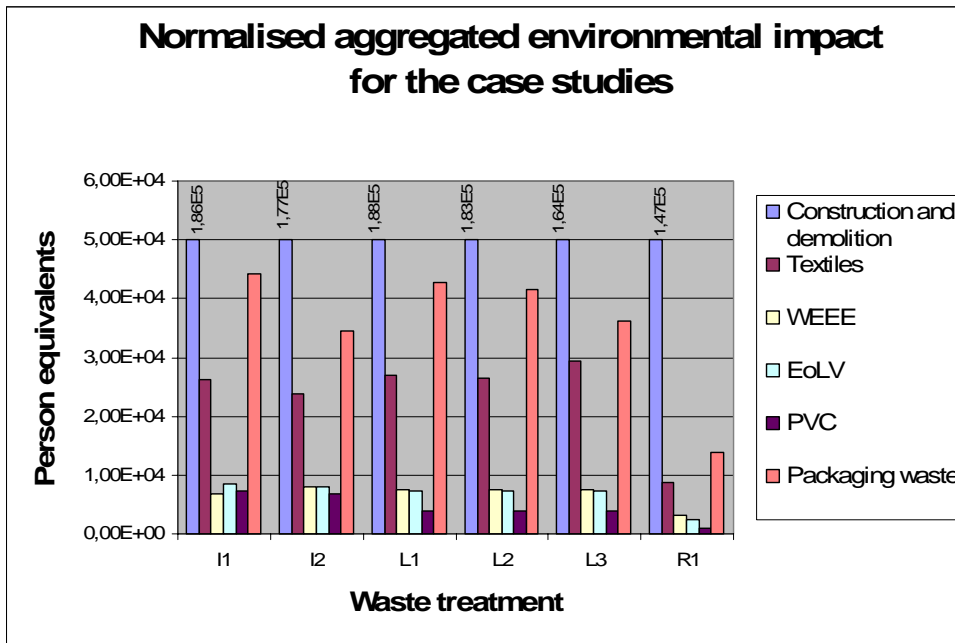

Figure 4.20: The calculated environmental impact of the waste from the selected cases in the EU.

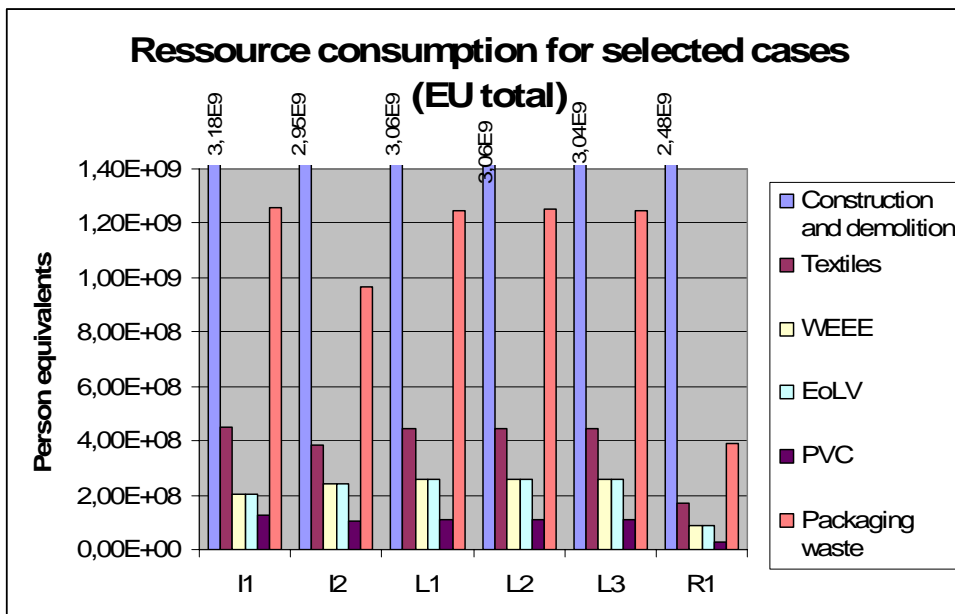

Figure 4.21: The calculated resource consumption of the waste from the selected cases in the EU.

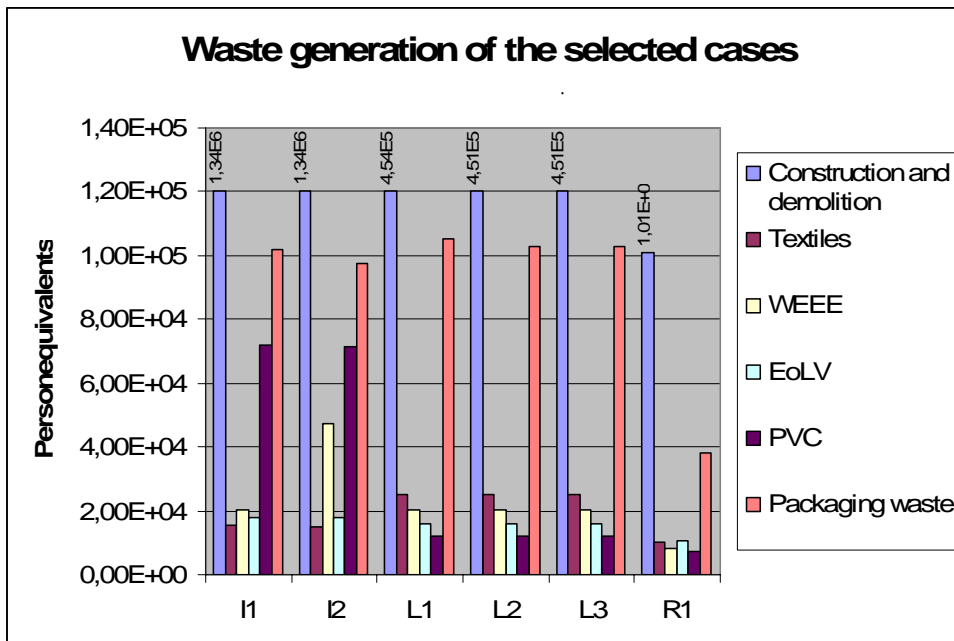

Figure 4.22: The calculated waste generation of the waste from the selected cases in the EU.

It is quite obvious that waste from construction and demolition by far has the largest environmental impact potential which is primarily due to the very large amounts (app. one order of magnitude higher amount than any of the other cases). Recycling does not reduce considerably the potential impact of this waste. This is in contrast to the other cases where recycling clearly is the environmentally best option reducing impacts with app. 50%.

Concerning PVC it should be mentioned that hazardousness is not considered in the result. Thus, the hazards from additives like heavy metals are not included. These are particularly a problem in old PVC still in use where re-granulation or reuse will re-circulate the additives into new PVC. This problem is also not evident in the hazardousness score in table 4.10.

4.6.2 Conclusion and recommendations

The following general recommendations can be made from the environmental assessments:

- The production (and extraction of raw materials) stage bears a significant part of the environmental impact in the life cycles of the materials and in the cases. Therefore the more directly a product or material can be re-used the less environmental impacts are caused, for example it is better to recycle PVC material into PVC material than into its components which can then be used for the production of new materials. Of course it is even better to reuse the product if possible. (An issue not taken into account here which is rather specific for PVC is that due to the life time of PVC and the use of heavy metal stabilisers in older PVC a simple re-granulation or re-use would again distribute PVC with heavy metals onto the market. This issue is inconsistent with the general conclusion).
- Regardless of whether prevention is in place or not, recycling seems for all materials to be the second best environmental option, whereas it is not clear whether incineration or landfill is the better. This is highly dependent on whether or not the incinerator applies energy recovery. Waste prevention policies and actions will therefore be most environmentally effective if applied where materials are not recycled to a large extent.

-
- Aluminium has a high environmental impact potential regardless of the waste management option. Recycling is somewhat less than other options. Policies and actions to prevent aluminium waste are therefore environmentally beneficial.
 - Organic waste contributes significantly to nutrient enrichment, primarily in the production stage. Therefore prevention of organic waste in all life cycle stages would result in environmental improvement
 - Textiles are an area where waste prevention would have an impact since both land filling and incineration have considerably higher impact potentials than recycling. As mentioned in section 4.3.5.8, prevention through reuse is currently the major outlet route for textiles in countries like Denmark.
 - When assessing waste flows the following seems to be of particular environmental concern per unit:
 - Total municipal solid waste
 - Textile and leather HZW
 - HZW from agriculture, and
 - Recycling of sewage sludge
 - Waste from energy production and hazardous waste
 - Taking the EU total waste generation into account environmental concerns seems to be centred on:
 - Total municipal solid waste
 - Total manufacturing waste
 - Mining and quarrying
 - Energy production waste
 - Hazardous waste

It should be emphasised that the assessments made are based on assessment of materials not including the use stage. When shifting the assessment from materials to products or waste streams, a more specific assessment may be necessary for specific products groups to ensure that no sub-optimisation is introduced due to the exclusion of the use stage. For example, this could be the case if the material weight of a given product is decreased resulting in a decrease in quality causing a shorter life time and a higher throughput rate and therefore also more waste.

4.7 References

Afval Overleg Orgaan (AOO) (2000), *Programma Gescheiden Inzamelen van Klein Chemisch Afval* (GIKCA, Programme Separated Collection of HHW), AOO, Utrecht, The Netherlands.

Afval Overleg Orgaan (AOO) (2000): *Programma Gescheiden Inzamelen van Klein Chemisch Afval* (GIKCA, Programme Separated Collection of HHW), AOO, Utrecht, The Netherlands.

Ashford, N.A and Miller, C.S. (1991): *Chemical Exposures – Low Levels and High Stakes*. Van Nostrand Reinhold, New York, NY.

CARACAS (1998): *Risk Assessment for Contaminated Sites in Europe - Scientific Basis*. Vol. 1. LQM Press, Nottingham, UK.

CENR/5-99/001 (1999): *Ecological Risk Assessment in the Federal Government*. Committee on Environment and Natural Resources of the National Science and Technology Council, Executive Office of the President, Office of Science and Technology Policy, Washington D.C.

Christensen, T.H. (Ed.). (1998): *Waste Technology*. Teknisk forlag A/S. Copenhagen (in Danish).

Collins, M. & Aumônier, S. (2002): Streamlined Life Cycle Assessment of Two Marks & Spencer plc Apparel Products. January 2002. Reference 7815.

Dall, O., Christensen, C.L., Hansen, E., Christensen, E.H. (2003a): *Resource savings by waste treatment in Denmark*. Environmental Project no. 804. Danish Environmental Protection Agency. (In Danish)

Dall, O., Lassen, C., Hansen, E., (2003b): *Waste indicators*. Environmental Project no. 809. Danish Environmental Protection Agency.

DEPA (2005) Waste statistics 2004. Danish EPA, 2005.

Energi E2, Elkraft, Elfor, Elsam and Eltra (2000): *LCA on Danish Power and Heat*. Main report, October, 2000 (in Danish).

ETC/ACC – European Topic Centre on Air and Climate Change (2006): Expert meeting on the estimation of CH₄ emissions from solid waste disposal sites with the First Order Decay method of the Working groups I (Inventories) of the EU Climate Change Committee. 8 - 9 March 2006, EEA, Copenhagen, Denmark.

European Commission (2003): Towards a thematic strategy on the prevention and recycling of waste. Communication from the Commission, COM(2003) 301 final. Brussels, 27.5.2003.

European Commission (2004): Communication from the Commission to the Council and the European Parliament: Towards a Thematic Strategy on the Sustainable Use of Natural Resources. Brussels, 1.10.2003, COM(2003) 572 final.

European LCA Study Weighs In On Vinyl Debate -

<http://www.vinylbydesign.com/site/tertiary.asp?TRACKID=&VID=2&CID=10&DID=469>

Gendebien, A., Leavens, A., Blackmore, K., Godley, A., Lewin, K., Franke, B, and Franke, A (2002): *Study on hazardous household waste (HHW) with a main Emphasis on hazardous household chemicals*. Final Report for the European Commission, Directorate General Environment. WRC Brussels. Ref. CO 5089-2.

Gendebien, A., Leavens, A., Blackmore, K., Godley, A., Lewin, K., Franke, B, and Franke, A (2002) Study on hazardous household waste (HHW) with a main Emphasis on hazardous household chemicals. Final Report for the European Commission, Directorate General Environment. WRC Brussels. Ref. CO 5089-2.

Glickman, T.S. and Gough, M. (ed.) (1995): *Readings in Risk*. Resources for the Future, Washington D.C.

Herczeg, M., Carlsen, R., and Nemeskeri, R.L. (2005): *Feasibility assessment of using the Substance Flow Analysis method for chemical information on macro-level*. ETC/RWM discussion paper commissioned by the EEA, Copenhagen, DK

Holm, O., Hansen, E., Lassen, C., Stuer-Lauridsen, F., Kjølholt, J (2002): *Heavy Metals in Waste. Final Report*. February 2002. Project ENV.E.3/ETU/2000/0058, European Commission DG ENV. E3.

Holm, O., Hansen, E., Lassen, C., Stuer-Lauridsen, F., Kjølholt, J (2002) Heavy Metals in Waste. Final Report. February 2002. Project ENV.E.3/ETU/2000/0058, European Commission DG ENV.

E3. http://air-climate.eionet.europa.eu/docs/meetings/060308_expert_mtng_waste_ch4_emiss/meeting060308.html

ISO (2000): *ISO series 14040 to 14049 on Environmental management & Life cycle assessment*. International Standardisation Organisation, Geneva, Switzerland. www.iso.org

ISWA and UNEP (2002): *Industry as a partner for sustainable development: Waste Management*. The Beacon Press, Boston MA, USA.

Larsen, H.F.; Helweg, C.; Pedersen, A.R.; Boyd, H.B.; Lauresen, S.E.; Hansen, J. (2000): *Chemicals in Textiles*. Environmental Project No. 534 2000 (in Danish).

McCally, M. (ed.) (2002): *Life Support, The Environment and Human Health*. The MIT Press, Cambridge, Massachusetts.

Moll, S.; Acosta, J. and Villanueva, A. (2004): *Environmental implications of resource use – insights from input-output analyses*. European Topic Centre on Waste and Material Flows, Copenhagen (download: <http://waste.eionet.eu.int/Publications>)

Nielsen, P.H.; Nielsen, A.M.; Weidema, B.P.; Dalgaard, R. and Halberg, N. (2003): *LCA food data base*. www.lcafood.dk.

OECD (2000): *Strategic waste prevention. OECD reference manual*, ENV/EPOC/PPC(2000)5/FINAL. Paris, 2000.

Ottoboni, M.A. (1991): *The Dose Makes the Poison*. Van Nostrand Reinhold, New York, NY.

OVAM (2004): *Methodology for determining the relative significance of the impact of industrial waste products on the environment in Flanders*. Public Waste Agency of Flanders (OVAM), 2004.

Plinke, E., Wenk, N., Wolff, G., Castiglione, D. & Palmark, M. (2000): *Mechanical Recycling of PVC Wastes. Final Report*. Study for the DG XI of the European Commission. In cooperation with Plastic Consultant (Italy) and COWI (Denmark). Basel/Milan/Lyngby, January 2000.

SAEFL (1998a): *Life Cycle Inventories for packagings – Volume I*. Environmental Series No. 250/I. Swiss Agency for the Environment, Forests and Landscape. Berne, 1998.

SAEFL (1998b): *Life Cycle Inventories for packagings – Volume II*. Environmental Series No. 250/II. Swiss Agency for the Environment, Forests and Landscape. Berne, 1998.

Schmidt, A and Strömberg, K (2006) *Recycling in LCA-system expansion*. Miljønyt no.81, Danish EPA (In Danish).

Stranddorf, HK, Hoffmann, L., Schmidt, A (2003): *LCA technical report: Impact categories, normalisation and weighting in LCA*. Update on selected EDIP97-data. http://www.lca-center.dk/lca-center_docs/showdocformacro.asp?token=9&id=041104075344&type=doc&fname=EHN_Microsoft+Word+-+Delprojekt+4+-+Technical+report+-+nmVOC2_22.pdf

Stranddorf, H, Hoffmann, L and Schmidt, A (2005). *Impact categories, normalisation and weighting in LCA*. Environmental news No. 78, 2005. Danish Ministry of Environment, Environmental Protection Agency.

Toxic Data Bias and the Challenges of Using LCA in the Design Community -
http://www.healthybuilding.net/pvc/Toxic_Data_Bias_2003.html

Uncertainty in LCIA of Toxic Releases - <http://www.scientificjournals.com/si/lca/Pdf/aId/1414>

UNEP – United Nations Environmental Programme (2003): *Evaluation of environmental impacts in life cycle assessment*. Meeting report. Borghetto Lodigiano, Italy. ISBN: 92-807-2144-5

Upton, A.C. (1990): *Environmental Medicine*. In *The Medical Clinics of North America*, Vol. 74, No 2. W.B. Saunders Company, Philadelphia PA, USA.

US EPA (1998): *Guidelines for Ecological Risk Assessment*. Risk Assessment Forum, US EPA, Washington D.C.

USEPA(2006) Priority Chemicals and Fact Sheets.
<http://www.epa.gov/epaoswer/hazwaste/minimize/chemlist.htm> and linked fact sheets.

USEPA (2003): Background Document for Life-Cycle Greenhouse Gas Emission Factors for Clay Brick Reuse and Concrete Recycling. EPA530-R-03-017, November 7, 2003

USEPA (2005): *National Priority Chemicals trend report 1999-2003*.
<http://www.epa.gov/epaoswer/hazwaste/minimize/trends.htm>

USEPA (2006) *Priority Chemicals and Fact Sheets*.
<http://www.epa.gov/epaoswer/hazwaste/minimize/chemlist.htm> and linked fact sheets.

van der Voet E, van Oers L and Nikolic I (2003): Weighting materials: not just a matter of weight - Development and application of a methodology to rank materials based on their environmental impacts. Draft final report by CLM (Leiden University, Netherlands) for RIVM.

Waste technologies LCA -
http://www.cfd.rmit.edu.au/programs/life_cycle_assessment/waste_technologies_lca

Weidema, B (2003): *Market information in life cycle assessment*. Environmental project no. 863, Danish EPA

Weidema, B., Nielsen, AM., Christiansen, K., Norris, G., Notten, P., Suh, S., Madsen, J. (2005): *Prioritisation within the Integrated Product Policy*. Environmental Project No. 980, 2005. Danish EPA, Danish Ministry of the Environment.

Weidema, B., Nielsen, AM., Christiansen, K., Norris, G., Notten, P., Suh, S., Madsen, J. (2005) *Prioritisation within the Integrated Product Policy*. Environmental Project No. 980, 2005. Danish EPA, Danish Ministry of the Environment

Wenzel H, Hauschild M, and Leo Alting. (2000): *Environmental Assessment of Products*. Kluwer Academic Publishers, Massachusetts/Springer Verlag, ISBN 0 412 80800 5

5 EXISTING WASTE POLICIES AND ACTIONS

The survey includes information on waste prevention actions with the policy/strategy that force the action, year of implementation, country covered, target for the policy/strategy (products/materials in focus), general description of the action and references to further studies of the action.

Waste prevention actions are considered as the concrete measures (projects, actions, practices etc.) actually implemented by producers, consumers or other actors aiming at preventing waste generation, whereas 'waste policies' are (set of) policy measures and instruments that have induced the implementation of the concrete actions in order to fulfil certain political targets.

The cases are summarised and, finally, survey tables will present the relation of different waste prevention actions to products/waste fractions/waste streams as well as the relation of waste prevention actions to policies.

The survey is the first attempt to generate a link between waste fractions, waste prevention options and policy measures/instruments and, finally, to innovation. This link will be supported by identified general cohorts of waste prevention actions as well as described regulatory regimes, including waste prevention policies/strategies, these actions and their impacts have derived from.

The survey provided in this chapter is based on a literature study of easily available reports i.e. reports made by OECD and ETCW:

- 'Strategic waste prevention', Environment Directorate, Environment Policy Committee, OECD, 2000.
- 'Toward waste prevention performance indicators', Environment Directorate, Environment Policy Committee, OECD, 2004.
- 'Case studies on waste minimisation practices in Europe', Jacobsen and Kristoffersen, European Topic Centre on Waste, EEA, 2002.
- A small selection of secondary literature.
- Survey/literature study focusing on East European countries.

These reports have been supplemented with examples from the ETCW online database on waste prevention. The selection of cases is described in the following and in Table 5.2 an overview of the outcome of the literature study.

5.1 Definition and selection of waste prevention actions

The practical steps involved in setting up a Waste Prevention programme have been described by OECD (2000):

1. Having a national waste prevention policy plan with specific goals in place. ...
2. Focussing on priorities and mapping out the programme. ... attention be given to the six ingredients of a waste prevention programme: 1) The particular instrument(s) chosen to foster waste prevention, 2) Specific waste streams to be targeted, 3) Specific generators of concern, 4) Mandatory or voluntary quantitative objectives targets that are measurable, 5) Milestones and timeframes, 6) Means for evaluating performance.
3. Getting financial incentives in sync. ...
4. Securing expertise and manpower. ...
5. Identifying budgetary resources. ...
6. Informing, educating, and gaining support. ...
7. Instituting partnerships. ...

8. Delivering the programme. Some national or municipal government bodies will launch a full-scale initiative when applying a programme. Others will start more slowly. In any case, it will be important not to overwhelm the targeted waste generators and other stakeholders all at once. A focussed message with clear milestones will be preferable. Part of programme delivery will include promoting accountability: 1) for efficient programme oversight within the government body, 2) for appropriate actions by lower level governments, where appropriate, and 3) by industry, consumers and other waste generators.
9. Weaving in a monitoring system. A well functioning monitoring system will be fundamental to help underpin most of the efforts above. ... waste prevention monitoring methods may include regular record keeping protocols, surveys and questionnaires, case studies, and participatory approaches.

The EU Member States ‘shall establish, in accordance with Article 1, waste prevention programmes ...’ that are integrated in waste management plans or as separate programmes (EU, 2005). The member states shall assess different waste prevention options and evaluate the programmes regularly. Examples on such programmes are presented in the summary on waste prevention actions.

5.1.1 Generic strategies and measures

OECD (2000; based on Stahel (1990)) presents a list of generic strategies for waste prevention; see the following table 5.1.

Table 5.1: List of generic strategies for waste prevention

<p>Strategy of long term use:</p> <ul style="list-style-type: none"> • Design of durable products/components • Increase “useful time” of products/components by re-using: <ul style="list-style-type: none"> ○ Repairing (to save broken products/components from the landfill). ○ Maintenance (to prevent the break-down of products components). ○ Improvement (to modernise the products/components; for example updating). • Re-marketing (for different purpose than for original product/component) <p>Strategy for more efficient use:</p> <ul style="list-style-type: none"> • The design of eco-efficient products/components: <ul style="list-style-type: none"> ○ Material-intensity (reducing the consumption of material during manufacturing and use). ○ Multi-purpose (the product serves several purposes). ○ Standardisation (components fit many products). • System solutions: <ul style="list-style-type: none"> ○ Producing the service/profit in different operational ways (e.g., substitution). ○ Avoiding unnecessary functions (producing the service in a simpler way without the need for extra service). ○ Combining different strategies as comprehensive, system-oriented solutions. • Sales and marketing approaches: <ul style="list-style-type: none"> ○ The right to use alternatives instead of the physical product (loaning, leasing, renting). ○ Communal use and divided use (e.g. laundry, public transportation, hotel rooms). ○ Providing, when appropriate, the service instead of the product (e.g. telephone answering service instead of answering machine). ○ Selling the results instead of the products (outsourcing). ○ Incentives to returning (deposits, pre-paid returns). ○ Service availability (providing the service near the consumers, thus avoiding transportation).
--

The OECD waste prevention strategies are integrated in the EU list of waste prevention measures (EC, 2005a) which is presented in Table 5.2. Here measures are regrouped according to the life-cycle phases: design, production, consumption (use), and waste generation.

Table 5.2: Waste Prevention Measures as defined by EC (2005a)

Measures that can affect the framework conditions related to the generation of waste:

1. The use of planning measures, or other economic instruments affecting the availability and price of primary resources.
2. The promotion of research and development into the area of achieving cleaner and less wasteful products and technologies and the dissemination and use of the results of such research and development.
3. The development of effective and meaningful indicators of the environmental pressures associated with the generation of waste at all levels, from product comparisons through action by local authorities to national measures.

Measures that can affect the design and production phase:

4. The promotion of eco-design (the systematic integration of environmental aspects into the design with the aim to improve the environmental performance of the product throughout its whole lifecycle).
5. The provision of information on waste prevention techniques with a view to facilitating the implementation of Best Available Techniques by industry.
6. Organise training of competent authorities as regards the insertion of waste prevention requirements under this Directive and Directive 96/61/EC.
7. The inclusion of measures to prevent waste production at installations not falling under Directive 96/61/EC. Where appropriate, such measures could include waste prevention assessments or plans.
8. The use of awareness campaigns or the provision of financial, decision making or other support to businesses. Such measures are likely to be particularly effective where they are aimed at, and adapted to, small and medium sized enterprises and work through established business networks.
9. The use of voluntary agreements, consumer/producer panels or sectoral negotiations in order that the relevant business or industrial sectors set their own waste prevention plans or objectives or correct wasteful products or packaging.
10. The promotion of creditable environmental management systems, including ISO 14001.

Measures that can affect the consumption and use phase:

11. Economic instruments such as incentives for clean purchases or the institution of an obligatory payment by consumers for a given article or element of packaging that would otherwise be provided free of charge.
12. The use of awareness campaigns and information provision directed at the general public or a specific set of consumers.
13. The promotion of creditable eco-labels.
14. Agreements with industry, such as the use of product panels such as those being carried out within the framework of Integrated Product Policies or with retailers on the availability of waste prevention information and products with a lower environmental impact.
15. In the context of public and corporate procurement, the integration of environmental and waste prevention criteria into calls for tenders and contracts, in line with the Handbook on environmental public procurement published by the Commission on 29 October 2004.
16. The promotion of the reuse and/or repair of appropriate discarded products, notably through the establishment or support of repair/reuse networks.

The measures listed by EU indicate that waste prevention actions may be directed at encouraging changes in the design, production and consumption of products. However, when applying many of

these measures it will not be possible to distinguish between waste prevention effects and waste minimisation effects - or the actual policies will result in both prevention and minimisation. Also, the measures are not necessarily independent as some measures refer to other measures e.g. eco-labelling refers to 'List of undesirable substances' and guidelines for public green procurement often refer to products with eco-labels or energy labels.

The ultimate success of waste prevention action lies in their ability to foster innovations and change design and use practices from an environmental and health perspective. Therefore the policies to be employed as waste prevention policies involve all kinds of innovation and consumption targeting policies. At large however, the dispositions of the impacts from waste are made outside the normal reach of waste actions and policies. Accordingly, the EU list of waste prevention measures does not address the fact, that most existing policies are not considered in a waste perspective, and may therefore not be realised as interconnected with the waste prevention agendas.

5.1.2 Description of waste prevention cases

The waste prevention cases have been described by four main parameters:

- Waste prevention action
- Products/Materials/Substances in focus
- Policy measure/Instruments
- Implementation context

In addition to these parameters country, year of implementation, general description and environmental effect will be presented. The survey will be presented in tables in order to make the cases comparable as shown in the generic table outline; see Table 5.3.

Table 5.3: Table used for description of waste prevention cases.

Title		Waste Prevention Action	
Policy measure/instrument			
Year	Country	Target	
Description			
Environmental effect		Implementation context	
Reference			

A complete list of identified case stories are presented in annex 2. A number of case stories are selected for presentation in this chapter. The selection is done with the aim of achieving links between waste fractions as identified in chapter 3, and the waste prevention actions, policy measures/instruments, and eventual resulting innovations as discussed in chapter 2.

The waste fractions for which statistical information is available are in some cases very broad i.e. they include two or more material fractions. However, in order to describe the link between waste, waste prevention action, policy measure/instruments, and innovation it is necessary that waste prevention actions as well as innovative efforts are related to specific materials. Waste policy measures/instruments can be related to waste flows and to materials. Where the information on the context of implementation or policy patterns (see definitions in section 2.2.3) is available they will

be presented in the table summarising individual waste prevention cases under the headline 'Implementation context'.

The criteria for selection of cases can be set up as follows i.e. the different waste fractions have to be covered, the different waste prevention actions have to be covered, and the different waste policies/strategies:

- Waste fraction - municipal waste (glass, plastics, metals), manufacturing waste (glass, plastics, metals), packaging waste (glass, plastic, cardboard, metals, wood), paper and cardboard, construction and demolition waste (glass, plastics, metals),
- Waste prevention action
- Waste policy/strategy

The cases *have been selected* so that all potential waste fractions are covered.

5.2 Waste prevention actions

The implementation plan presents a number of sources that have to contribute to the present survey. Table 5.4 presents the outcome of the literature survey. Regarding waste prevention, the outcome of the study of the specified sources has been sparse. Therefore, the specified sources have been supplemented with a selection of other sources. The summaries of the waste prevention actions are presented in annex 2; however, a few key-cases are presented in this chapter.

Table 5.4 Outcome of the literature survey

"Strategic waste prevention", Environment Directorate, Environment Policy Committee, OECD, 2000.	The report presents an annex dealing with "Generic strategies and examples of waste prevention by different actors" (headlines).
"Toward waste prevention performance indicators", Environment Directorate, Environment Policy Committee, OECD, 2004.	Cases presented in the OECD report: <ul style="list-style-type: none"> • Municipal waste • Batteries: domestic batteries i.e. NiCd-batteries and button cells • Packaging • Paper • Construction and demolition (C&D) waste Batteries and packaging are included in an extended form compared to the present report whereas municipal waste, paper and C&D waste are included from the present description in the OECD report.
"Case studies on waste minimisation practices in Europe", Jacobsen and Kristoffersen, European Topic Centre on Waste, EEA, 2002.	Cases presented in the EEA-report: <ol style="list-style-type: none"> 1. Austria: Minimisation of landfilling of biodegradable municipal waste 2. Austria: End-of-life vehicles 3. Denmark: Landfill tax on construction and demolition waste 4. Denmark: Weight-related collection schemes for household waste 5. Germany: Producer responsibility for packaging waste 6. Greece: Minimisation of packaging waste 7. Ireland: Cleaner production pilot demonstration programme 8. The Netherlands: Organic household waste action programme 9. Sweden: Producer responsibility for packaging waste 10. UK: Envirowise - waste minimisation programme Case 5, 7, 10 can be considered as waste prevention according to the applied definition; however, they all include a degree of waste minimisation. The other projects can be characterised as waste minimisation.
A small selection of secondary literature.	See the list below.
Survey/literature study focusing on East European countries.	See the list below.

The waste prevention actions included in the survey are:

- Denmark: Tax on packaging
- Denmark: Eco-labelling scheme (European/Scandinavian)
- Hungary: Eco-labelling scheme
- Denmark: Tax/subsidies on rechargeable NiCd batteries
- EU/Denmark: Regulation of dangerous substances in certain batteries
- EU: Packaging and packaging waste
- Germany: Packaging waste - Duales System Deutschland AG (DSD)
- Ireland: Cleaner Production Pilot Demonstration Programme (CPPDP)
- Ireland: Cleaner Greener Production Programme (CGPP)
- United Kingdom: Envirowise - waste minimisation programme
- OECD/Specific countries: Municipal waste
- OECD/Specific countries: Paper
- OECD/Specific countries: Construction and demolition (C&D) waste
- Austria: Repair shop indexes

-
- Italy: Reducing municipal waste and packaging waste
 - Different countries: Prevention dossier for packaging waste
 - Austria: Waste management concept
 - Belgium: Subsidies for waste prevention investment
 - Italy: Promotional programme for waste prevention
 - Austria: Dish loaning system for festivals
 - Belgium: PRESTI (Prevention stimulating programme)
 - Belgium: MAMBO 'less waste more profit' software
 - Germany: Hesse's enforcement programme obligation prevention or recycling of waste in installations subject to licensing
 - Hungary: Environmental product fee (for imported and domestic products)
 - Hungary: Deposit-refund system for glass and plastic bottles
 - Czech Republic: Voluntary agreements: Eco-labelling
 - Poland: Reduction of hazardous substances in packaging
 - Germany: Electrical and Electronic Equipment Act
 - The Netherlands: Home composting of organic waste
 - The Netherlands: Avoidance of junk mail (advertisements/free, local newspapers)

The characteristics of the waste prevention actions included in the survey varies from legislation focusing on one product e.g. NiCd batteries to programmes focusing on industrial sectors e.g. "Cleaner Greener Production Programme".

5.3 Exemplary cases

The selected waste prevention cases presented below are examples covering the following policies:

- ban/limitations on substances
- tax/subsidies
- support for research/innovation
- producer responsibility
- voluntary labelling

The complete collection of cases is presented in annex 2.

Title Eco-labelling Denmark		Waste Prevention Action Product substitution Substitution of chemical substance Reduction of chemical substance Minimising energy consumption Minimising material consumption Re-use	
Policy measure/instrument National eco-labelling scheme / Voluntary			
Year 1998	Country Denmark	Target Numerous product groups	
Description The Danish Eco-labelling scheme consists of the European eco-label: "The Flower" and the Nordic eco-label: "The Swan". Both labels are based on widely accepted criteria and the label are given to the products showing the best environmental performance (\approx best 33%). Criteria for new product groups are developed continuously. The purpose of the criteria is to initiate innovation. Examples on product covered by the different labels are: <ul style="list-style-type: none"> • The Flower: all purpose cleaners for sanitary facilities, copying and graphic paper, indoor paint and varnishes, portable computers. 23 product groups and approx. 50 licences in Denmark. • The Swan: audiovisual equipment, cleaning products, primary batteries, rechargeable batteries and battery chargers, personal computers, printing papers. 77 product groups and more than 400 licences in Denmark. <p>The actual waste prevention action depends on the specific product group. Therefore, a general relation between the waste prevention action and innovation can not be established.</p>			
Environmental effect Eco-labels support consumption of products with best environmental performance. Env. effects within different product groups can be found in Cadman & Dolley (2004)		Implementation context Eco-label is a "decision support" tool that helps private and professional consumers to buy environmental friendly products. It support other policy measures and is often supported by information campaigns etc.	
Reference http://www.ecolabel.dk/ Cadman & Dolley (2004)			

Title Tax on sealed nickel cadmium accumulators/ batteries and compensation for collection and reuse of sealed nickel cadmium accumulators/ batteries		Waste Prevention Action Substitution of chemical substance Re-use	
Policy measure/instrument Tax/subsidies			
Year 1993/	Country Denmark	Target Ni-Cd rechargeable batteries Cadmium	
Description The consolidated act stipulates the tax for different kinds of nickel cadmium batteries. The notice establish rule for collection of used nickel cadmium batteries. The batteries can be delivered ether to a municipal area for collection of waste or to a registered company. The subsidies for collection of Ni-Cd batteries are paid when a number of conditions are fulfilled. The conditions are: 1) the company is registered by the Danish EPA, 2) the batteries are collected in Denmark, 3) the collected Ni-Cd batteries are processed for reuse, 4) the collection is done in accordance with the Environmental Protection Law, 5) the companies reusing the batteries shall be established according to the EPL or similar foreign laws, 6) the Basel Convention for transport of waste are followed, 7) the collecting company are registered by the municipality, 8) the collecting company are registered in the municipality where handling and sorting before export is done, 9) the collecting company do not collect fees for receiving the batteries.			
Environmental effect In the years 1997-2002 32-58% of the mean potential were collected (Maag & Hansen, 2005).		Implementation context The regulation on hazardous substances in batteries is supported by eco-labels that tighten the accepted heavy metal content.	
Reference Danish Ministry of Taxation (1998). Consolidated Act on tax on sealed nickel cadmium accumulators (nickel cadmium batteries). Consolidated Act No. 561 of 3 August 1998. Danish Ministry of Environment and Energy (2000). Notice on subsidies in relation to collection and reuse of sealed nickel cadmium accumulators (nickel cadmium batteries). Notice no. 1062 of 4 December 2000. Maag & Hansen (2005)			

Title EU Directive on Packaging and Packaging Waste		Waste Prevention Action Reduction of chemical substance Minimising material consumption	
Policy measure/instrument			
Year 1996	Country EU/National implementation		Target Packaging Packaging Waste Heavy metals
Description The directive includes waste prevention as well as waste minimisation actions. The directive include articles on: 1. Prevention a. Member states shall ensure other preventive measures are implemented: national programmes and projects to introduce producer responsibility. b. The Commission shall help to promote prevention by encouraging the development of European standards and the Commission shall present proposals for measures to strengthen and complement enforcement ... 2. Recovery and recycling a. Recycling targets for recovering or incineration of packaging waste with energy recovery, b. Targets for recycling of packaging waste, and c. Minimum targets for recycling of specific packaging materials 3. Return, collection and recovery systems 4. Standardisation a. e.g. criteria and methodologies for life-cycle analysis of packaging 5. Concentration levels of heavy metals present in packaging Content of Cd, Cr(VI), Hg, and Pb shall be a. <600 ppm two years after implementation, b. <250 ppm three years after implementation, and c. <100 ppm five years after implementation; packaging made from lead crystal glass exempted. The evaluation of the directive (ECOLAS & PIRA, 2005) has been based on an LCA-based approach. The evaluation concludes: the packaging prevention plans were improved over the years; the limit values for heavy metals could be fulfilled for most of the materials (depending on amount of recycled material). For reuse they conclude: "In general, reuse systems are most likely to be environmentally beneficial when distribution distances are short and return rates are high (...), although there are many other factors that must be taken into account when assessing the environmental performance of any packaging system."			
Environmental effect NA		Implementation context NA	
Reference European parliament and Council Directive 94/62/EC of 20 December 1994 on packaging and packaging waste. Amended by: Regulation (EC) no. 1882/2003 of the European Parliament and of the Council of 29 September 2003. Directive 2004/12/EC of the European Parliament and of the Council of 11 February 2004.			

Title Envirowise - waste minimisation programme		Waste Prevention Action Minimising material consumption (Waste minisation)	
Policy measure/instrument Waste minimisation programme financed by the Department of Trade and Industry (DTI) and the Department of Environment, Transport and the Regions (DETR)			
Year 1994		Country UK	Target Not specified
Description The programme supports establishment of regional and local waste minimisation clubs. Means: <ul style="list-style-type: none"> • Improvement of management • Demonstration of financial benefits from reducing waste at source • Publications (e.g. good practise guides, environmental performance guides, and case studies) and seminars on waste prevention • Telephone support line • Free visits of consultants (<250 employees) <p>The programme has supported: Metal finishing, foundries, textiles, paper and board, glass manufacturing, glass manufacturing, printing, ceramics, food and drinking manufacturing/processing, speciality chemicals, and engineering. Total savings 178 mio. EUR/year.</p> <p>The programme co-operates with other programmes that provide support to business.</p> <p><i>Examples that include waste prevention will be selected for further description</i></p>			
Environmental effect 2000: <ul style="list-style-type: none"> • reduced raw material use >240,000 t/year • reduced waste disposal >1.1 mio. t/year • reduced waste consumption and effluent disposal >46 mio m³/year 		Implementation context NA	
Reference Jacobsen & Kristoffersen (2002). http://www.envirowise.gov.uk/			

Title Subsidies for waste prevention investment		Waste Prevention Action Strict avoidance Reduction at source Re-use	
Policy measure/instrument Economic instrument			
Year 2002	Country Belgium	Target MSW	
Description In 2002 the Flemish Government published a Subsidy Scheme for Investments on Waste Prevention. This Subsidy Scheme was established for local authorities willing to invest in facilities and services for waste prevention and waste management of household waste. Subsidies can run up to 70% of the investment cost when it concerns investments on waste prevention. Subsidies to improve waste prevention are given for reusable shopping bags, reusable beakers and lunchboxes.			
Environmental effect May 2003 - subsidies granted for: A) 10.192 Compost bins, B) 550 wormeries, C) 45 small fountains for drinking water, D) 2.000 reusable lunchboxes, E) 2.500 reusable biscuit boxes, F) 16.000 reusable beakers, G) 350 Education sets on composting, H) 12.200 reusable shopping bags.		Implementation context NA	
Reference ETCW, Database: Success Stories on Waste Prevention			

Title Electrical and Electronic Equipment Act		Waste Prevention Action Substitution of chemical substance Reduction of chemical substance (Re-use) (Recycling) (Disposal according to ecological standards)																																		
Policy measure/instrument Legislation: Producer obligation to take back WEEE waste																																				
Year 2005	Country Germany EU	Target Electrical waste Electronic waste																																		
Description The electrical and electronic equipment covered are: small and large household appliances, IT and telecommunication equipment, consumer equipment, electrical and electronic tools with exception of large-scale stationary industrial tools, toys, leisure and sports equipment, medical products, monitoring and control instruments, and automatic dispensers. The EEEA include paragraphs on product design and prohibited substances as well as clearing house, registration and financing guarantee. Finally, a separate collection system, a treatment and a recovery system shall be established. The substances considered are: mercury and mercury compounds, lead and lead compounds, cadmium and cadmium compounds, and hexavalent chromium. AEA Technology & REC (2005) have evaluated the implementation of the EU directives in the Member countries. The WEEE directive stipulates targets that have to be met by 31 December 2006: <table border="1"> <thead> <tr> <th>Product category</th> <th>Recovery target</th> <th>Recycling target</th> </tr> </thead> <tbody> <tr> <td>Large household appliances</td> <td>80%</td> <td>75%</td> </tr> <tr> <td>Small household appliances</td> <td>70%</td> <td>50%</td> </tr> <tr> <td>Information and telecoms</td> <td>75%</td> <td>65%</td> </tr> <tr> <td>Consumer equipment</td> <td>75%</td> <td>65%</td> </tr> <tr> <td>Lighting</td> <td>70%</td> <td>50%</td> </tr> <tr> <td>Tools</td> <td>70%</td> <td>50%</td> </tr> <tr> <td>Toys, leisure, sports</td> <td>70%</td> <td>50%</td> </tr> <tr> <td>Medical equipment</td> <td>na</td> <td>na</td> </tr> <tr> <td>Monitoring instruments</td> <td>70%</td> <td>50%</td> </tr> <tr> <td>Dispensers</td> <td>80%</td> <td>75%</td> </tr> </tbody> </table>				Product category	Recovery target	Recycling target	Large household appliances	80%	75%	Small household appliances	70%	50%	Information and telecoms	75%	65%	Consumer equipment	75%	65%	Lighting	70%	50%	Tools	70%	50%	Toys, leisure, sports	70%	50%	Medical equipment	na	na	Monitoring instruments	70%	50%	Dispensers	80%	75%
Product category	Recovery target	Recycling target																																		
Large household appliances	80%	75%																																		
Small household appliances	70%	50%																																		
Information and telecoms	75%	65%																																		
Consumer equipment	75%	65%																																		
Lighting	70%	50%																																		
Tools	70%	50%																																		
Toys, leisure, sports	70%	50%																																		
Medical equipment	na	na																																		
Monitoring instruments	70%	50%																																		
Dispensers	80%	75%																																		
Environmental effect NA		Implementation context The present act implements the EU RoHS and WEEE directives in German legislation.																																		
Reference eunomia (2006) Act Governing the Sale, Return and Environmentally Sound Disposal of Electrical and Electronic Equipment (ElektroG) of 16. March 2005. Directive 2002/95/EC of the European Parliament and of the Council of 27 January 2003 on the restriction of the use of certain hazardous substances in electrical and electronic equipment. Directive 2002/96/EC of the European Parliament and of the Council of 27 January 2003 on waste electrical and electronic equipment (WEEE) – Joint declaration of the European Parliament, the Council and the Commission relating to Article 9. AEA Technology & REC (2005). Research study into implementation of WEEE directive in EU 25 - Draft final report JRC 12/1 Updates.																																				

5.4 Relations to waste prevention actions

The waste prevention actions presented in the previous chapter are summarised and related to materials/waste fractions; see Table 5.3 or waste prevention policies/strategies; see Table 5.4. The relations between waste prevention policies/strategies, waste prevention actions and innovation is presented as figures/flow sheets.

5.4.1 Relations between waste prevention actions and materials/ waste fractions and policy measures/ instruments

Relations between waste prevention actions and products/materials are presented in Table 5.5. The relations are based on survey on waste prevention actions presented in annex 2.

Table 5.5: Relations between waste prevention actions and materials/waste fractions.

	Strict avoidance		Reduction at source			Reuse ¹	Comments
	Product substitution	Substitution of chemical substance	Reduction of chemical substance	Minimising energy	Minimising material consumption		
PVC foil (packaging)	X	X					
PE foil (packaging)					x		
Paper/cardboard (pack.)			x		x		
Glass bottles						x	
Aluminium cans						(x)	Recycling of material.
Packaging				(x)	x	x	D: DSD focus on reduction of weight and collection for re-use.
Primary batteries		(x)	x			(x)	Recycling of materials.
Rechargeable NiCd batteries	X	(x)				(x)	Rechargeable NiCd batteries may be substituted by NiMH or Li-ion batteries.
Municipal waste					x	(x)	Individual composting is considered as waste prevention in some countries.
Hazardous waste		X	x				
Paper					x	(x)	Recycling of materials.
C&D waste		X	x			x/(x)	Certain building materials may be reused after reconditioning.
Industrial waste		X	x		x	x	Production waste may be reused in the same process without leaving the plant.
Organic household waste						x/(x)	Individual composting is considered as waste prevention in some countries.

1. The definition of reuse varies from country to country.

X Strong relation between material/waste fraction and waste prevention action.

x Relation between material/waste fraction and waste prevention action.

(x) The relation depends on national definitions of waste prevention and waste minimisation.

Table 5.5 reflects the problems with a general definition of reuse as the definition varies in different countries. As an example individual composting can be mentioned. In some countries individual composting is considered as reuse whereas other countries consider composting as material recycling. A number of the cases referred from other compilations on waste prevention therefore lead to confusion in the systematic presentation of the waste prevention actions. The policies described do sometimes cover both waste prevention and recycling.

Table 5.6 present relations between waste prevention actions and policy measures/instruments. The relations are based on survey on waste prevention actions presented in annex 2.

Table 5.6: Relations between waste prevention actions and policy measures/instruments.

	Strict avoidance		Reduction at source			Reuse	Comments
	Product substitution	Substitution of chemical substance	Reduction of chemical substance	Minimising energy	Minimising material consumption		
Law: ban on chemical substances/materials	X	X	x				
"List of undesirable substances"		X	x				The list acts as a signal on future regulation i.e. encourage producers to avoid certain chemical substances.
Classification of chemical substances/ Labelling of products		x	x				
Tax on raw materials, energy, packaging, pollutants, production waste			x	x	x		
Subsidies	X	X	x	x	x	x	
Producer responsibility for waste					X	X	
Eco-labelling	X	x	x	x	x	x	Eco-labelling often support one or more of the other instruments or tighten up limit values given in legislation on e.g. batteries.
Energy labelling				x			
Environmental Product Declaration	(x)	(x)	(x)	(x)	(x)	(x)	EPD environmental conditions and allow the consumer to choose environmental friendly product
Public green procurement	X	x	x	x	x	x	Public green procurement often supports the other instruments or tighten demands given in legislation on e.g. batteries.
Consumer awareness	X	x	x	x	x	x	
Voluntary agreements	X	x	x	x	x	x	
Design requirements/ Design for Environment (DfE)	X	x	x	x	x	X	

X Strong relation between policy measure/instrument and waste prevention action.

x Relation between policy measure/instrument and waste prevention action.

(x) Environmental Product Declarations allows comparison of environmental performance of similar products. The relation to waste prevention action is indirect.

Table 5.6 indicate that laws and subsidies are the most relevant policy measures are the most relevant for initiating product substitution and substitution of chemical substances. Actions based

on producer responsibility as well as design for environment (DfE) are expected to be the most relevant for minimising material consumption and reuse.

No systematically analyses of the efficiency of different policy measures have been identified; however, specific instruments e.g. EU Directive on packaging and packaging waste (ECOLAS & PIRA, 2005) and eco-labelling (International Institute of Environmental Economics, 2001; Cadman & Dolley, 2004; Locret & Roo, 2004) have been evaluated.

5.4.2 Relations between waste prevention actions and innovation

This section presents the relation between waste prevention actions and innovation by using a comprehensive description of an example. The selected example is Batteries and it illustrate that different policy measures/instruments often acts in combination and lead to successive improvements and that the outcome of voluntary measures is the best environmental performance but the most significant change is supposed to be a result of legislation. The explanation is that legislation covers all products whereas voluntary measures only cover the products bought by people that are aware of environmental questions (i.e. green consumers).

Batteries

Production, marketing and use of batteries are regulated by EU directives (followed by national legislation), eco-labelling, tax on production, and subsidies on collection of used products. The time line for the development within political regulation is presented in Figure 5.1 along with information on development of NiCd-free rechargeable batteries (Noréus, 2000). The limit values for heavy metals are presented in Table 5.5.

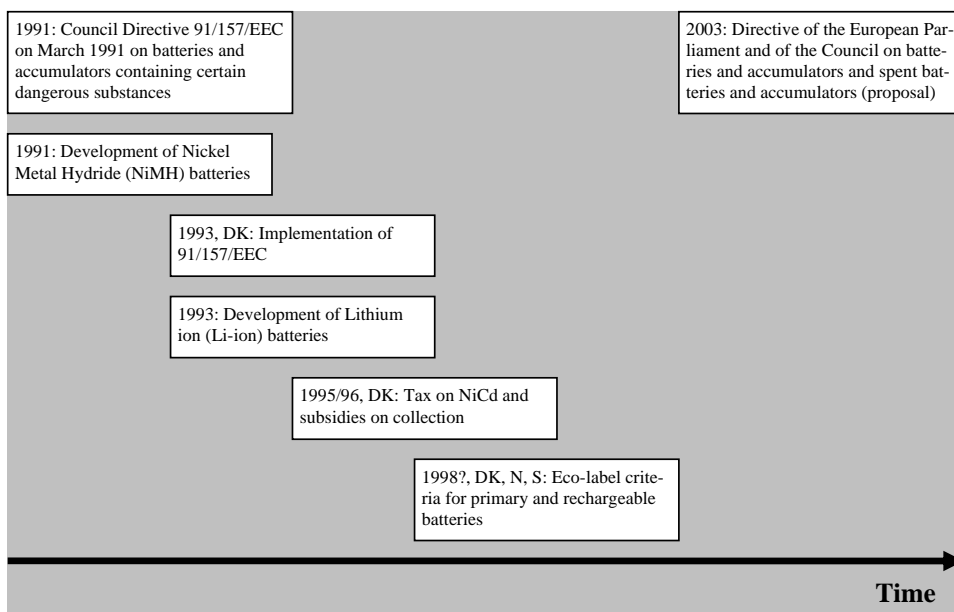

Figure 5.1: Presentation of the development of the policy regarding heavy metals in batteries and development of substitutes for NiCd batteries.

The Danish Act on batteries and eco-labelling criteria are the regulations in force and they have been developed since their first versions. However, the mentioned limit values (Table 5.7) represent

the value in force at present. A proposal for a new EU directive on batteries is presented by the Commission in 2003 but not approved yet.

Table 5.7: Development in limit values for heavy metals in batteries.

	EU Directive 91/157/EEC on batteries 1991	DK: Act on batteries (historical) 1993	DK: Act on batteries 1999	Eco-label: Primary batteries 2003	Eco-label: Rechargeable batteries 2003	Proposal - EU Directive	EU Directive 2006/66/EC on batteries 2006
Cd – cadmium		250 mg/kg ⁴	250 mg/kg ⁴	1 mg/kg		250 mg/kg ⁴	20 mg/kg ⁶
Hg - mercury	250 mg/kg ¹ 500 mg/kg ²	250 mg/kg ¹ 500 mg/kg ² 25 mg ⁴	5 mg/kg ³ 25 mg ⁴	0.1 mg/kg	0.1 mg/kg	5 mg/kg ³ 5 mg/kg	5 mg/kg ⁵
Pb – lead		4,000 mg/kg ⁴	4,000 mg/kg ⁴	10 mg/kg		4,000 mg/kg ⁴	
As+Cd+Pb					20 mg/kg		

1. Sale prohibited; “all other alkaline batteries ...” “button cells exempted”
2. Sale prohibited; “alkaline batteries for prolonged use in extreme conditions ...”
3. Sale prohibited for batteries with a concentration of mercury > 5 mg/kg.
4. Labelling required for batteries containing more than 25 mg mercury or with at concentration of cadmium > 250 mg/kg or lead > 4,000 mg/kg.
5. Button cells with not more than 20 g Hg/kg is exempted.
6. Portable batteries and accumulators.

Table 5.7 illustrates that national legislation adapt and sometimes strengthen the limit values given by EU and then influence the revision of the EU directive. According to an evaluation of substitution of rechargeable NiCd batteries by Noréus (2000), Nickel-Metal Hydride (NiMH) batteries were introduced in 1991 and Lithium ion (Li-ion) batteries in 1993. Japanese battery manufacturers are the leading producers of NiCd batteries and of the substitutes. The evaluation emphasise that cadmium free batteries were available for a number of applications (2000) but batteries for especially power tools were still under development. An expected ban on sales of NiCd batteries and products containing NiCd batteries were mentioned as a driver for the development; however, this initiative has been removed from the latest proposal for a directive on batteries. The new directive on batteries (EU, 2006) require establishment of collection schemes and targets for the member states: minimum collection rates: 25% by 2012 and 45% by 2016. Development of new recycling and treatment technologies will be encouraged by the EU. The new directive does also prohibit heavy metals exceeding certain limit values and require labelling with information on specific heavy metal. The ban on sales of NiCd batteries has been replaced by labelling requirements.

The effect of the eco-labelling of batteries has not been evaluated; however, in Denmark five producers are marketing eco-labelled primary batteries and one producer is marketing eco-labelled rechargeable batteries.

5.5 Conclusions

The survey presents 30 waste prevention cases. The compilation of waste prevention cases mentioned in the implementation plan do not give sufficient coverage of the relevant waste streams and therefore the literature survey has been extended with a number of other sources. However, not all materials can be covered as waste prevention actions/policies have not been developed yet.

The sources for the presented cases are different and therefore, the level of detail varies. Only a few sources include information on quantitative environmental effects of the waste prevention actions – and some of the waste prevention actions are recently implemented and therefore the effect can not be determined yet. The different definition/understanding of waste prevention – especially reuse – in different countries also results in some confusion in the systematic description of the cases. However, the qualitative environmental effects are related to the applied waste prevention action. Product substitution may result in reduction of potential environmental impacts in the raw material extraction phase (resource consumption) as well as the potential impacts of waste management. Substitution of chemical substances may reduce potential environmental impacts in the production as well as disposal phase (e.g. reduction in toxicity of waste incineration residues from e.g. NiCd-batteries). Reduction of chemical substances may reduce potential environmental impacts of material recycling (e.g. reduction of emission of heavy metals from recycling of paper). Minimising material consumption as well as reuse reduces potential environmental impacts of raw material extraction phase (resource consumption as a result of e.g. reduced material weight per packaging unit and e.g. refilling of bottles).

Some of the cases illustrate the timeline from an EU directive to implementation in individual countries and tightening of the limit values in the national implementation together with voluntary labelling schemes e.g. batteries. These initiatives have resulted in reducing the general heavy metal content of batteries and combined with efforts on collection of discarded batteries the input of heavy metals to waste incineration has been reduced. The present legislation – tax as well as compensation for collection and reuse of sealed NiCd-batteries – together with expectations on more far reaching restrictions (e.g. total ban of cadmium in batteries) has resulted in development of alternatives to NiCd-batteries for most purposes. The expected ban has not been adopted yet and therefore the market penetration of cadmium free batteries depends on the price and the environmental awareness of the consumers, however, the present legislation has resulted in collection of 32-58% of the average potential in Denmark leading to a similar reduction in the input of nickel and cadmium to waste incineration. The recently published battery directive has replaced ban on cadmium with labelling requirements.

The potential environmental impacts of EU packaging directive have been evaluated by use of scenarios. The effectiveness and the efficiency of the actual implementation have also been evaluated. One of the aims of the directive was to develop packaging prevention plans (PPrP) and both the quality of the plans and the number of plans has increased over the years. Regarding heavy metals the evaluation shows that most of the packaging materials complies the limit values. The effect could not be evaluated quantitatively; however, the input of heavy metals to the waste management system is expected to decrease. Regarding reuse the overall conclusion is that reuse of transit packaging increase whereas reuse of primary packaging decrease. A number of factors are important to consider when evaluating the environmental performance of a packaging system. Especially the transport distance is important and 100-1000 km is shown to be the feasible distance for reuse systems. In Denmark tax has been introduced for packaging and deposit for reusable beverage containers and the experience is that to low tax and deposit do not give the expected effect due to adoption to the low tax or to low profit of returning beverage containers (compared to the required effort).

Generally, there has been focus on heavy metals many years, and therefore, policies aiming at reducing the heavy metals in waste often have a high market penetration. This can be explained by the fact that producers are aware of the problems and therefore abreast of the development of heavy metal free products.

Table 5.8 present potential waste prevention actions that can be applied for the waste streams considered in chapter 4.

Table 5.8: Relations between the selected waste prevention oriented policy areas and waste prevention actions.

	Strict avoidance		Reduction at source			Reuse	Comments
	Product substitution	Substitution of chemical substance	Reduction of chemical substance	Minimising energy	Minimising material consumption		
Aluminium	x				x		
Plastics	x	x	x		x		
Iron					x		
Paper			x		x		
Cardboard			x		x		
Organic waste					x	x/(x)	Individual composting is considered as reuse in some countries.
Mineral materials					x		
Glass					x	x/(x)	Reuse (i.e. refilling of bottles)/Recycling of waste glass.
Textiles (polyester)					x		
Textiles (cotton)		x	x		x		
Wood					x		
Other materials not included (heavy metals, POP's, and organic solvents etc.)	x	x	x				

x Indication of waste prevention actions relevant for the prioritised waste streams.

Table 5.8 illustrate that minimising material consumption is an applicable option for all the waste streams. In general, the waste prevention action to be applied will depend on the actual use of the material and therefore the waste streams can not be related to one action. However, table 5.6 gives some ideas on how to handle the different waste streams.

5.6 References

AEA Technology & REC (2005). Research study into implementation of WEEE directive in EU 25 - Draft final report JRC 12/1 Updates.

Cadman, J. & Dolley, P (2004). The direct and indirect benefits of the European ecolabel Final report. A final report produced for DG Environment at the European Commission. AEAT in Confidence.

ECOLAS and PIRA (2005). Study on the implementation of Directive 94/62/EC on packaging and packaging waste and options to strengthen prevention and re-use of packaging. Final report 21 February 2005, 03/07884/AL.

EU (2005). Proposal for a directive of the European Parliament and of the council on waste. Brussels, 21.12.05, COM(2005) 667 final.

EU (2006). Directive 2006/66/EC of the European Parliament and of the Council of 6 September 2006 on batteries and accumulators and waste batteries and accumulators and repealing Directive 91/157/EEC.

eunomia (2006). Household waste prevention policy research programme. Interim report. eunomia research & consulting.

International Institute of Environmental Economics (2001). Evaluation of the environmental effects of the Swan Eco-label - Final Analysis. TemaNord 2001:516, Nordic Council of Ministers.

Jacobsen, M. and Kristoffersen, M. (2002). Case studies on waste minimisation practices in Europe. European Topic Centre on Waste, European Environment Agency. Topic report 2/2002.

Locret, M.-P. & de Roo, C. (2004). The EU Eco-label - less hazardous chemicals in everyday consumer products. The European Consumers Organisation. BEUC/X/010/2004.

Maag, J. & Hansen, C.L. (2005). Collection potential for nickel-cadmium batteries in Denmark. Environmental Project no. 1004. Danish Ministry of Environment, Environmental Protection Agency.

Noréus, D. (2000). Substitution of rechargeable NiCd batteries. A background document to evaluate possibilities of finding alternatives to NiCd batteries. Arrhenius Laboratory, Stockholm University.

OECD (2000). Strategic waste prevention. OECD reference manual. ENV/EPOC/PPC(2000)5/FINAL.

OECD (2004). Towards waste prevention performance indicators. OECD. ENV/EPOC/WGWPR/SE(2004)1/FINAL.

6 CASE STUDIES OF THE IMPACTS OF WASTE MINIMISATION POLICIES ON INNOVATION

The analysis of waste prevention and minimisation policies and their impacts on innovation need to be empirically grounded and can due to the lack of evaluations and data not cover all materials, technologies, products, and waste flows. This leads evidently to a need for selecting some cases, which in summary gives an overall and covering picture of the interdependencies that can illustrate the interaction between waste-related policies and innovations and give a background for policy recommendations.

This chapter presents the results of five selected cases where waste prevention and minimisation policies and other policies have demonstrated impacts both on waste generation and on innovations in products or processes. The term waste minimisation policies is used to cover a broader range of policies still including waste prevention as an important part. In many cases the policies employed cannot be defined strictly to focus on waste prevention, due to the fact that 'good prevention' will not contribute to the waste stream. This implies that the case studies analyse the interaction between a broader collection of policies having an impact on or avoiding waste and innovations improving product efficiency, reducing materials consumption, energy use, hazardous substances, and ways of handling products for re-use or waste for re-cycling.

6.1 Selection of cases for detailed study

From the outset the idea of focussing on a limited number of rich illustrated cases to support the policy analysis and the recommendation of policy measures is based on the observation, that single policy instruments most often are difficult to isolate concerning their impact, and that they most often do not operate alone, but together with a number of policy actions of which some may be supportive and others may be counterproductive.

One of the important aspects of the cases to be selected is that they have a historic timeline documented through the available information. Another aspect is the documentation of controversies around the stability of the environmental problem and regulated objects. The timeline is important as many policies cannot be associated with their impact on innovation based on just a few years of empirical support, as the impact on innovation often will lead to changes not responding immediately on the regulatory pressure and can only be identified with some delay. Also the complexity of eventual 'wait and see' or even counter programs by companies and other stakeholders may lead to delayed responses, where the coherence of policy actions sets the agenda more than the single policy as mentioned above. Another aspect that promotes an interest in extended cases is the importance of learning processes also in policy where the problem definition, the translation of the environmental object of policy and the choice of instruments are involved in an interaction constantly surrounded by controversies about the relevance and importance of these policy actions.

6.1.1 Criteria and candidates for case studies

To sum up, the following elements must be covered to create a coherent and comparable set of cases, where contributions from several countries can be integrated and discussed:

- An explicit and precise identification of the environmental object of regulation or intervention and its eventual translation or even substitution throughout the timeline of the case.
- The problem and impacts making this environmental object policy relevant and what events or changes that creates urgency around regulating the object.

-
- An illustration of the patterns of policy actions, coherent or divergent, prioritisation and timeline of actions, and the controversies involved concerning choice of policy actions and instruments.
 - A description of the institutional configuration (organisation, knowledge, competences developed and contextual reasons) which shapes the core of the regulatory regimes established.
 - A discussion of the measures or instruments engaged to regulate the environmental problem and how these measures are supposed to fit into a longer time frame of changes in the significance of the environmental problem.
 - Illustrations of how actors are responding to the regulation and how eventual innovative actions to circumvent the problem or to create counter programs evolve among the actors being regulated.
 - Waste prevention, dematerialisation, substitution, reuse, minimisation, precaution, increased efficiency, balances and switches between volume, hazardousness and risk.
 - Demonstrating environmental impacts potentially giving them high priority in future waste policy actions.

Based on the project's activities in collecting and documenting waste statistics, the environmental impacts of waste streams, and recognised waste prevention policies a number of areas with potential cases were listed for further consideration comprising:

- power production and the production of oil and other fossil fuels (gasoline) and their waste products like ashes and slag (cinder)
- biomass eventually also including paper as waste product and its eventual re-use or energy conversion through bio-processing or incineration
- electronics and the product and process regulation for hazardous substances and waste handling (take back systems eventually including end-of-life vehicles)
- regulation of the use and substitution of plastics and additive substances, and here eventually taking PVC as the main focus
- packaging materials as an important and special fraction of waste which has been targeted in several installed waste policies with the use of voluntary agreements and charges
- building materials including minerals, isolation, and glass is a high volume part of the waste flow and relevant for its potential for reuse

Also energy saving technologies, batteries, and metals has been considered for case studies. But as the primary objective of this study is to produce an overview over different policy instruments and patterns, the criteria for choosing and delimiting the cases also had to be related to the recognised and known innovations and the access to available policy studies.

6.1.2 Cases selected

The resulting selection of cases resulted in the following list:

1. **Product oriented:** Electronics, producer responsibility, and take back – RoHS – WEEE – including areas of product and process regulation for hazardous substances and waste handling - car manufacturing and take back policies.
2. **Material oriented:** PVC regulation of the use and substitution of PVC and additives including the different policy controversies and stakeholder activities.
3. **Consumption oriented:** Wastes generated along the life cycle of a product and policies that try to influence the manufacturing of the products - including policies related to the design of these products and the consumer choices at the market.

-
4. **Sector oriented:** Building materials including minerals, isolation and glass – including the problems of redefining waste streams.
 5. **Waste stream oriented:** Packaging materials as a special fraction of waste – glass bottles and plastic bags – take back and reuse and recycling options.

The main contribution both at a sector level and in relation to the type of innovation policies and the targeted processes in society these policies address have been identified to make sure that the cases cover a variety of aspects.

Also the impacts and wastes from energy production for use in power production, transports, and industry does represent an important waste stream as does the impact from base chemical industries, but in both cases the localisation of these sectors activities is rather unequally distributed among countries and regions and the data are still difficult to get due to the two sectors influence and careful information strategies, which makes the access to studies of innovations and wastes more difficult.

Each of the five cases is built around a template structure with roughly the same six sections:

1. Material flows and their relation to waste generation – this section describes the size and the type of materials and products within the product or material area, which is in focus.
2. Environmental objects and their constitution – this section gives an overall description of the environmental objects and impacts, which have been in focus.
3. LCA studies within the area – this section summaries the results from some important LCA studies within the area.
4. Policies influencing waste and innovation – this section analyses which policies which have influenced the waste generation, the waste management, waste minimisation and waste prevention and have influenced innovation.
5. Policy impact, patterns and regimes – this section analyses what type of policy patterns and regimes that have influenced waste minimisation and prevention and innovation.
6. Effectiveness of policies – this section discusses the effectiveness of the analysed policies in terms of their environmental achievements and highlights in some cases some future challenges.

The outcome of this selection of cases is to cross-fertilize learning as a basis for policy improvements, while we do not aim at providing a formula for optimal choices of policy. This would be challenging and certainly attractive, but at the same time not a serious endeavour seen in the light of our findings in the theoretical framework reported in Chapter 2.

6.2 Electronic waste, producer responsibility and hazardous substances

Electronics waste is in recent years getting more attention due to the technologies pervasive character and the content of hazardous substances and the use of composite materials. The regulations on wastes from electronics and its hazardousness has had a direct focus on the products and the latest EC regulations has introduced producer responsibility for the waste handling as new strategy to impact the design and production of electronics and electrical products. Waste prevention policies have therefore in this case taken the products as the outset for defining the objects of regulation.

efficient software and growing consumption. Furthermore, the resource and energy use in the production phase is not in a linear relationship with the decreasing size of the end products, that is resource and energy use is not decreasing as a result of miniaturization. In a waste perspective the miniaturization process implies an increased integration and thus more difficult separation of the components.

Cars are included in this case study to illustrate in contrast some of the potentials but also conditions for a policy based on producer responsibility and eventual take back of used and old products. The case of car take back policies will not be covered in all detail.

6.2.2 Environmental impacts and their constitution

Just two decades ago the electronics industry was seen as a 'garden industry' with rather limited impacts on resource consumption and even contributing to a clean environment with no important pollutions coming from the production facilities. This popular view has been sustained through the possibility of locating electronics companies almost everywhere and with only little of the traditional elements of pollution to the surrounding community. A quiet and clean industry with emphasis on occupational health and safety issues and often even protecting the production lines more from the 'pollution' from the workers operating them than the opposite. This view has changed dramatically due to the fast growing amounts of electronics products consumed and the identical growth in electronics in the waste streams. EEE is today a pervasive technology in toys, tools, office equipment, kitchen appliances, ICT and medical equipment.

The most important environmental aspects of EEE are the use of hazardous substances in the production of the miniaturised components, the use of heavy metals in soldering and components and in batteries. Also the use of cleaning agents and specialised oils and plastic materials for insulation are posing threats to the environment. Due to the number of hazardous substances involved in EEE, the most important being metals and flame retardants it was identified that leakage from landfills may be an important environmental concern (Kuehr and Williams, 2003).

Last but not least the growing complexity of integrated components makes it almost impossible to take back these for the purpose of reuse, as they integrate treated silicon, small metal fractions, composite materials and plastics and other substances. Present costs of recycling a TV or a computer is approximately 0,5 EUR pr. kg (Denmark) and leaves a large fraction of second grade material (smelting slag and 'gunk' plastics – a near worthless amalgam of different types of plastic) which is difficult integrate into new high grade products.

Recycling at present is more grunt (rough mechanical separation and crushing) than chemistry – although several promising technologies for separation exist on a lab-scale. The present available recycling technology only achieves a rough separation of components. As a result of this a large fraction of recycled glass from CRT is contaminated with heavy metals to be recycled as raw glass, and equally the majority of the plastics fraction is contaminated with brominated flame retardants and mixed with different types of plastics to be used as standard quality raw material. Bromine compounds are added as halogenated flame retardants to circuit boards, connector mouldings and housings in order for these to meet safety standards of flammability. In a fire situation however, highly toxic dioxins may be produced from these compounds as safe end-of-life incineration requires temperatures greater than 800 °C and excess of oxygen. The use of PVC in casings and for cable insulation causes a problem in case of fires as this will release chlorine and result in the creation of acid which often causes more damage in combination with water used to extinguish the fire than the fire itself making electronic equipment and installations defunct. But given the amount of electronics in the home and workplace it is not sensible to avoid using flame retardants.

6.2.3 LCA studies covering electrical and electronic equipment

Due to the integrated character of EEE it is very difficult to provide the data that are necessary in order to perform quantified evaluations of the relevant environmental impacts as for example life cycle assessments covering the magnitude of different processes and products. There are only few LCAs in the publicly available literature. A book called 'Computer and the Environment' (Kuehr and Williams, 2003) covers part of the area nicely and most of the following will be based on that book, but also to some extent on a ph.d. thesis by Anders Andr  (2002) and a guidance for green public procurement of office electronics in Denmark (Willum, 2004).

An overall life cycle of EEE was shown in figure 6.1.

Andr  (2002) have worked on LCAs within the electronics industry. He ascribes the difficulties of making LCAs on electronics to the vast amount of unit processes involved and the lack of detailed data sets for products components and manufacturing processes. He mentions that the data does exist but that industry don't know how to reveal them without disclosing confidential information in a market that is rapidly evolving. As a consequence the data coverage of manufacturing (and raw materials extraction) is estimated to be as low as 50%.

Therefore, the following information gathered by Kuehr and Williams (2003) does not provide a complete picture, but rather an illustration of the life cycle impacts of electronics industry where the principal streams and impacts can be identified

Using a computer as example six aspects of manufacturing are distinguished:

1. Production of integrated circuits, IC's i.e. microchips
2. Manufacture of printed circuit boards
3. Manufacture of cathode ray tube (CRT) monitors
4. Manufacture of liquid crystal display (LCD) monitors
5. Production of bulk materials in computers and monitors (Steel, plastics etc.)
6. Production of specialised chemicals and materials for electronic manufacturing

The content of significant materials in a desktop computer is listed in table 6.1.

Table 6.1: Approximate contents of a desktop computer system estimated by Kuehr and Williams (2003) and Socolof et al. (2001) (LCD)

Material	Computer	CRT monitor (17")	LCD monitor (15")
	Amount (g)		
Glass		6817	590
Steel	6050	2830	2530
Copper	670	700	230 (wires and cables)
Ferrite		480	
Aluminum	440	240	130 (including lead and tin)
Plastics	650	3530	1780
Epoxy	1040	140	
Tin	47	20	40 (soldering material)
Lead	27	593	
Nickel	18		
Silver	1,4	1.24	
Gold	0,36	0.31	
Liquid crystals			2

Printed circuit boards			370
Other	96	98	58
Total	9040	15450	5730

It should be noted that laptop computers are winning ahead and that the amount of materials use in these are considerably lower. Also LCD screens are quickly replacing the consumption of CRT screens, but a considerable amount of old CRT screens are yet to be discarded.

For the different steps of the manufacturing, information was gathered by in Kuehr and Williams (2003) and summarised below.

Values estimated for producing microchips to one computer is given in table 6.2.

Table 6.2: Materials and energy used in the manufacturing of microchips (From Kuehr and Williams, 2003)

Material	Description	Amount per memory chip	Amounts used to make chips in one computer
Silicon wafer		0.25 g	0.025 kg
Chemicals	Dopants	0.016 g	0.002 kg
	Photolithography	22 g	2.2 kg
	Etchants	0.37 g	0.037 kg
	Total chemicals	72 g	7.1 kg
Elemental gases	N ₂ , O ₂ , H ₂ , He, Ar	700 g	69 kg
Energy	Electricity	2.9 kWh	281 kWh
	Direct fossil fuel	1.6 MJ	155 MJ
	Embodied fossil fuel	970 g	94 kg
Water		32 l	310 l

It is obvious that the manufacturing of microchips have a significant impact in the life cycle not least due its energy intensiveness. Note that chemical emissions are not addressse by quantity, thus depriving us the opportunity to e.g. make a toxicity impact assessment.

Making the printed circuit boards is somewhat less material and energy intensive but still demanding as shown in table 6.3.

Table 6.3: Materials and energy use in and emissions from circuit board production (Data from Japan) (Kuehr and Williams, 2003).

	1995 Japan use/emissions	Per desktop system (PC + CRT monitor)
Inputs		
Blank boards	73,318 tons	1.7 kg
Resin Etchants	2,789 tons	0.06 kg
Solder	3,188 tons	0.07 kg
Aluminum	1,650 tons	0.04 kg
Plastic	6,265 tons	0.14 kg
Electricity	1.17 billion kWh	27 kWh

Fossil fuel	244 million liter oil	5.6 liter oil
Embodied fossil resource	0.596 million tons	14 kg
Water	60.2 billion liter	780 liter
Outputs		
Waste acid	408600 tons	9.4 kg
Waste alkali	181234 tons	4.2 kg
Sludge	19771 tons	0.45 kg
Waste plastic	12522 tons	0.29 kg

In the printed circuit board (PCR) production chemicals has to be managed – metals, formaldehyde and brominated flameretardants – causing toxicity impact potential. However this cannot be quantified from the available literature.

The production of monitors will here focus on the LCD monitors since they are a rapid growing market. The available values for energy use etc. may already be a bit outdated due to the rapid technological development in the industry.

Table 6.4: Aggregate chemicals, energy and water use in the manufacture and assembly of a LCD monitor (Socolof et al, 2001)

Material/input	Amount used per monitor
Photolithographic and other chemicals	3.7 kg
Elemental gases (N ₂ , O ₂ , argon)	5.9 kg
Electricity	87 kWh
Direct fossil fuels (98% natural gas)	198 kg
Embodied fossil fuels	226 kg
Water	1,290 liter

For the production of electronics especially in the microchip production, extra high grade materials entailing additional environmental impacts are required. However, no data for these are publicly available. For example, the manufacture of a silicon wafer requires 2,150 kWh per kg silicon (corresponding to 53 kWh per computer) which is 160 times more than standard grade silicon (Kuehr and Williams, 2003). This is a major source of uncertainty in the EEE LCA.

Table 6.5 summarises the amounts of fossil fuels, chemicals and water consumed in the production of one desktop computer.

Table 6.5: Use for one desktop computer (Kuehr and Williams, 2003) NI= not included in analysis.

Item	Fossil fuel (kg)	Chemicals (kg)	Water (kg)
Semiconductors	94	7.1	310
Printed circuit boards	14	14	780
CRT picture tube	9.5	0.49	450
Bulk material- control unit	21	NI	NI
Bulk materials – CRT	22	NI	NI
Electronic materials/chemicals (ex. Wafers)	64	NI	NI
Silicon wafer	17	NI	NI
Manufacture of parts	NI	NI	NI
Assembly of computer	NI	NI	NI
Total	240	22	1,500

During the use stage all EEE consume electricity, but with the values estimated above the use stage of a computer only accounts for app. 25% of the total energy use in the life cycle (Kuehr and Williams, 2003). This will be valid for most products with a very high content printed circuit boards but not for electrical equipments e.g. a refrigerator where the use phase accounts for app. 96% of the energy use in the life cycle.

For comparison Andr e (2002) has summed up the key values for a digital telephone where mechanical components, due to their relatively larger mass, top all environmental impact categories with integrated circuits being second. The figures provided by him add to the findings of Kuehr and Williams (2003) showing a considerable environmental impact from the production of electronic components.

From the different options of end-of-life of EEE (see Figure 6.1: Landfill, incineration, recycling and reuse/resale) Kuehr and Williams (2003) show that extending the PC's life span through reuse/resale is considerably more environmental beneficial than just recycling. If one in ten computer are resold the total energy use is reduced 5.2-8.6 % where recycling of the materials only saves 0.43% by replacing demand for virgin materials. One reason for this is that the energy is invested in the complex components such as microchips rather than the bulk materials and the recycling still primarily handles the bulk materials and not the complex components.

6.2.4 Policies influencing innovation, environment and waste

Policies addressing several issues of EEE waste have existed for a number of years in EU countries as single compound initiatives (e.g. taxing Cd batteries) and take back systems. Prior to the EC WEEE Directive, separation and handling of electronics waste was undertaken in several EU countries already for some years (EC 2005). For instance in the UK, take back options have been supported since the late 1990ies and especially in the telecom sector figures have been high due to the former policies of rented equipment. The recently implemented EU directive on Waste from Electrical and Electronic Equipment (WEEE) is the main policy from the EC on electronics waste. WEEE is considered to be both a harmonization of the different already existing national policies as well as an obligation to 'catch-up' for the laggards among the European countries, as the implementation of WEEE follows a number of already existing national initiatives with regards to EEE waste in the EU countries including take back systems and special treatment of fluorescent lightning tubes, CRT screens and batteries, including phasing out of mercury batteries. Other important policies are the directive on the restriction of the use of certain hazardous substances in electrical and electronic equipment (RoHS), and the EU shipment rules.

Data to use for quantitative modelling of trends in European electronics waste is poor, and therefore calculations of the potential impacts of WEEE are of limited value (Crowe et al 2003, EC 2005). Instead the common reference of WEEE policies is qualitative projections of the development of EEE waste streams related to the continuously increasing demand for and use of electronic and electrical equipment. This poses a problem to more rationalistic attempts at modelling the effects of waste regulation measures as presented in Vaz et al 2001.

A recent study of the implementation process concludes that the WEEE system will have rather different impacts on the countries implementation as they have a very different starting point. A few have already installed collective collection systems for EEE waste while the new model being implemented in WEEE is not substantiated by any previous experiences: 'Additionally collective systems as run in the Netherlands, Belgium and Sweden are 'tried and tested' and represent the only approach that has so far been shown to work in practice. The clearing house model, on the other hand, lacks experience and data to make good analysis and comparisons with existing collective systems.' (AEA & REC 2006, v)

6.2.4.1 Waste as a product for export

A major problem with regards to assessing EEE waste policies is the definitions of waste, product, recycling and reuse. The term 'recycling' is already in use with very different meanings in different European countries: In Norway recycling includes reuse, material recycling and energy recovery. In The Netherlands recycling is defined as the proportion of materials not going to landfill or incineration. Recycling fees on EEE in European countries with already existing WEEE semi compliant systems are set as per item, per mass or specific to the product type as well as fixed annual fees for some products. As with 'waste', there is a need for clarification of the definition of 'reuse' and juridical provisions promoting it (ACRR 2003).

From the LCA study it can be concluded that waste prevention through reuse/resale is the most environmentally preferable for electronics since the main environmental impacts is due to the manufacturing stage. Recycling is primarily focused on the bulk materials which constitute less of an environmental problem than the printed circuit boards and other electronic components. (This may differ somewhat between products since Andr  (2002) found that the bulk materials due to their larger mass have the greatest impact in a digital telephone.) Concluding that reuse/resale is the most environmentally preferable however does not take into account that a very large fraction of products for reuse and resale are exported to third world countries.

It is a standing problem with electronics waste that large amounts of this evidently are exported as products to third world countries. Here products are taken apart and valuable components retrieved under unsafe and environmentally harmful conditions. The problem of waste export is related to the question of when products are waste and vice versa. The concept of waste is difficult, and not solved by the seemingly tautological definition of the directive: 'WEEE means electrical or electronic equipment which is waste ... including all components, thus assemblies and consumables, which are part of the product at the time of discarding.'

Formally it should be impossible to export WEEE to third world countries. The Basel Convention on the Control of Transboundary Movements of Hazardous Wastes prescribes a ban on exports of hazardous waste to non-OECD countries and a ban on exports of waste for disposal outside the EU and EFTA. The Basel Ban applies to export for any reason, including recycling. This is reflected in EU shipment rules that ban the export of hazardous waste in WEEE to non OECD countries as of January 2002 and the transportation directive (259/93) which specifies notification to relevant authorities prior to waste shipment. Export of waste out of EU is formally difficult even between EU countries. There are common objections to shipments between member states of waste for disposal due to principles of proximity and self-sufficiency. Furthermore sufficient environmental protection must be considered if the exported material is waste for recovery.

In the UK it is estimated that 133.000 tonnes of computer and telecommunications equipment was exported for re-use or recycling in 2003. 23.000 tonnes of this was 'grey market' equipment exported without the required documentation (AEA Technology 2005). Also 2 million old computer monitors and 1 million old TV's are estimated to have been exported – many to dismantling unsafe places or simply to be dumped. Another example is the export of used mobile phones which in Denmark amount to a substantial part of the phones taken back by retailers. These used phones are exported for reuse in e.g. Africa but the shipments contain both batteries and non functional phones as it is much cheaper to handle the testing and eventual re-assembly at the destination companies leading to discharge of electronics waste and hazardous materials under problematic and unregulated conditions.

In Massachusetts CRTs were to be 100% recycled by year 2000, which required a drastic increase in state subsidies to recycling facilities, but also a significant growth in export of old CRT's to China (The Basel Action Network 2002). It has reported that as much as 80% of EEE waste collected in North America for recycling were actually shipped to Asia where valuable material is

recovered in dangerous conditions and the remaining parts dumped locally. Also, a substantial export of e.g. waste cables is reported to take place from EU to Asian countries, especially China. Very little consumer-based electronic waste has true reuse value, and claims of export for reuse should therefore be scrutinized more thoroughly. The EEE waste export issue demonstrates that the definition of waste and product is in practical terms insufficient to cope with the factual problems while waste policies makes these types of exports economically attractive. The EEE export of also implies that statistical data for waste EEE is no longer reliable, as large quantities of waste must be expected to be redefined by exporters as products, whereby the actual effects of EEE waste policies will no longer be clearly measurable with regards to the amounts of not environmentally properly treated waste.

6.2.4.2 WEEE and the perspectives of producer responsibility

Directive 2002/96/EC of the European Parliament and of the Council of 27 January 2003 on waste electrical and electronic equipment (WEEE) is designed to take full effect by 2008. The primary goal of the WEEE Directive is to reduce WEEE disposal, provide a producer take-back system, improve product design in order to prevent impact from production, and to increase the products ability to be recovered, reused and recycled. There is a broad definition of the producer as it can be either the company that: a) manufactures and sells EEE under their own brand name or b) resells EEE under their own brand name, exports or imports EEE into the EU.



Every new product put on the market after August 13 2005 must bear a label that verifies that it will be separately collected and bears the name of the producer according to an EU standard. The producers need to either pay into a collective fund or take full responsibility of their own product. Until August 2011 producers may place a visible fee on the sale of new EEE to show the cost of collection, treatment, recycling, reuse, and environmentally sound disposal of historical WEEE.

The aim of WEEE is to introduce a producer responsibility as a mechanism for pushing responsibility for end-of-life management up the supply chain. WEEE is designed to ensure that market pressures are directed at achieving environmental protection through the management of end-of-life electronic and electrical equipment (EEE). However, the complexity of the business to business relations along the supply chain limits the applicability of producer responsibility (Hume et al 2002). A company in the middle of the supply chain will not necessarily be able to exert adequate pressure upstream in the supply chain to ensure design for the environment and in turn improved end-of-life management. On the other hand, major producers of brand products having distributed production facilities may be able to establish control over their supply chains and thereby also impact the upstream producers beyond the impacts from the bans of certain substances in the products.

The difficulties of applying greater pressure on the supply chain may appear for many companies to be the main barrier to achieve the perceived benefits of WEEE through improved product design. Some larger corporations may avoid contributing to collective WEEE management systems by taking full responsibility of their own products setting by establishing independent systems and providing guarantees for their operation. The majority of the producers will however simply add the WEEE system costs to price of the products. The collected waste will be traded as a new product by private companies that have the dual goal of retrieving the valuable components effectively and discarding the remaining fraction with as little cost as possible. As a result there will be increased private interest in the previously mainly public or quasi-public activities of incineration and landfilling.

While the main argument for introducing a common European legislation on EEE leading to the WEEE Directive is to support waste prevention and especially environmentally friendly design of

products including the choice of materials, energy efficiency, and their readiness for reuse or dismantling and recovery of materials, the specific mechanisms and the implementation of WEEE points in a different direction. Especially the way the individual producer responsibility (IPP) is interpreted and implemented in the countries demonstrates this weakness. The implementation study from IPTS concludes that producers are 'missing incentives in the Directive for better environmental performance, as they will be charged for their products on, e.g. a weight basis, independently from the attributes of their products in the same category.' (AEA & REC 2006, 54) The most important impact of the regulation seen from a waste prevention perspective – the improvement of precautionary design practices – is not supported significantly.

The economic incentives of the related waste management system are related to the producer responsibility question. Incentives for using landfill or incineration will greatly influence the implementation of WEEE in different European countries. These questions need to be addressed in order to achieve environmentally improved design. The lesson from the existing private activity of waste export as products is that increased private activity in the waste sector requires more effective public control, as it is through clear and unavoidable demands that new standards and requirements will be pushed back through the supply chain. The primary and first response to WEEE is thus a delegation of responsibilities and tasks from the public to the private sector rather than an innovative change in the design and manufacturing of EEE products.

Reuse is explicitly protected in WEEE, allowing refurbishment without producer consent. However, there are no clear drivers to encourage the development of repair and reuse activities. Main barriers to repair and reuse are: Multiple rapid changing design of appliances, the composition of appliances where plastic products are more difficult to repair than metal ones, the cost of repair may exceed the costs of manufacturing of new product, the decreasing quality and lifespan of new products on the market, a lack of definition and standards of repair processes and the lack of commercial tools for secondary markets. Some producers have products that are designed for recycling, including easy access to disassembly and identification of materials and components. But there are only very few examples of companies that integrate already used EEE components into new products. Furthermore some equipment has been developed with significantly reduced water and energy consumption, making reuse of older models both economically and environmentally inappropriate. As earlier stated, no current trends support increased repair and reuse of EEE products.

The WEEE implementation strategies are quite diverse among the European countries depending on the different national points of outset. Some of the countries with already existing systems had developed these in close connection to public municipal waste systems and continue to have their collection facilities as a main component in their institutional approach. Other countries with no previous arrangements have implemented WEEE through the use of private collection and treatment services. It is still too early to conclude on the effectiveness of the different implementation strategies, besides from noting that the countries with already existing systems achieve the highest recycling rates and that WEEE may not add much to the effectiveness of these systems.

In Hungary for example the implementation sets clear targets and guidelines in accordance with the WEEE directive. However, it is not yet possible to assess the impact of this specific implementation as it is also regulated by the special Hungarian Environmental Product Charge Law, where payment of the charge can be avoided by reaching the recycling targets for specified streams of products including the EEE products. Other specific elements of the implementation of WEEE relate to the possibility of large customers of electronics and electrical products to avoid paying the waste charges collected by the producers by taking over the responsibility of handling the waste and paying the costs on their own. This adds to the unclear impact on the product chain of the individual product, though this may lead large buyers of specialised electrical products to care about the possible end-of-life impacts.

6.2.4.3 RoHS and the regulation of hazardous substances

The WEEE directive requires that producers report information on ‘dangerous substances and preparations’ but without further specifications of these materials. Some OEMs are reported to have started collecting data on a vast number of materials, while many only focus on the six substances banned by the RoHS directive. RoHS covers lead, mercury, cadmium, hexavalent chromium, polybrominated biphenyls (PBCs), and polybrominated diphenyl ethers (PBDEs).

The question of which materials and substances to consider as problematic is a common issue for companies that have implemented Environmental Management Systems, EMS such as the ISO 14001. EMS experiences are that many companies look to lists of chemicals such as the Danish EPAs ‘List of unwanted chemicals’ (at present 68 substances that are considered environmentally problematic or toxic but still legal to use due to substitution problems). Although this kind of list has no formal regulatory standing it has some impact as many purchasing agents try to avoid these chemicals.

6.2.4.4 Other regulatory activities related to electronics

WEEE take-back and producer responsibility is also in development in Korea, Canada, Japan and China which is also reported to be developing its hazardous materials law to be comparable to RoHS. Japan has had a minor recycling fee for consumers to pay on all TVs, washing machines, refrigerators, and air conditioners since 2000. The fee is not big enough to cover recycling costs. But the manufacturers do not resent them, as many Japanese companies compete on environmental virtues. Japan is developing legislation similar to the RoHS directive and many of the major Japanese electronics manufacturers specify lead free components. The Japanese experience supports one of the conclusions of most empirical policy studies which is that if there is common agreement among the stakeholders on the policy aim it is easier to implement coherent measures, while the specific type of measure is of less relevance to the successful policy.

6.2.4.5 The EU end-of-life vehicle regulations

EU’s End-of-Life Vehicles (ELV) regulation came into effect 3 March 2006. It is similar to the WEEE in also being a producer responsibility regulation. But when comparing insights from the ELV regulation to the WEEE it should be remembered that the EEE market is much more fragmented than the automobile market. The basic demands of the ELV regulation are:

- importers are forced to establish collection networks for their own brand
- to ensure that value is recovered from 85% of the weight (95% by 2015)
- provide free take-back for last owners by 2007.
- ELVs can only be treated – meaning scrapped – by authorised dismantlers
- restricted use of heavy metals (Pb, Cd, Hg, Cr-6) in new vehicles

Many EU countries had voluntary policy schemes with no economic instruments running as precursors of the ELV directive. In these, the car industry has usually played the role of coordinator distributing tasks among the industries in the ELV chain. The main task has been the creation of networks of dismantlers/shredders linked to individual car companies. This was a major organisational innovation given the previously existing limited relationships between the car industry and post-consumer ELV-treatment. Even though new networks have been constructed innovation activities directed at Design for Dismantling and Design for Recycling still takes place only inside the individual car companies. Redesign includes developing lists of undesired substances in the specifications imposed on component suppliers, and thus a ‘responsibility transfer’ takes place in the ELV chain (Mazzanti & Zoboli 2005).

In order for the policy to be effective markets for materials and energy from the recycled components must develop. Mazzanti and Zoboli argue from studies of the ELV chain that it is

important to take into consideration how incentives are moved up or down in the supply chain when economic instruments are applied.

In Hungary the 2004 on end-of-life vehicles is probably the only one emphasising waste prevention. Producers are obliged to design automobiles, in cooperation with their suppliers, furthermore to improve their technologies and products, so that it will decrease the use of hazardous components, support maintenance and repair and help the recycling, recovery and safe disposal of disassembled components. The decree also requires an increase of the rate of recycled materials.

An important other instrument is the 2003 law on registration defining a tax to be paid on the occasion of the Hungarian registration of used imported cars. Also the import of cars older than 10 years is banned. Since the purchasing power is significantly less in the new Member States than in the old one, a massive inflow of used, older and cheaper cars has started in the last decade. However, since the average age of cars is already significantly higher in the new Member States, this process is regarded environmentally harmful locally, since it results in the increase of end-of-life vehicles. This is the reason why Hungary and also The Czech Republic, Poland, Luxembourg, and Austria try to limit the import of older, used cars. However, the European Commission has pointed out that the registration tax is discriminatory, since it is not applied for used cars sold domestically. This demonstrates some of the problems in coordinating policies that support the waste measures without resulting in un-equal distributing of loads and costs among the member states.

6.2.5 Policy impacts – patterns and regimes at play

The WEEE introduction of producer responsibility can be seen as an attempt to influence the design of more environmentally friendly products, but it may alternatively be assessed as a system for transferring costs and responsibilities from the public sector to the private sector. Especially in countries with weak waste policies and no system for waste collection and sorting based on separating e.g. the electronics waste stream for separate treatment, this will lead to improvements in waste handling and reduce impacts as all producers and importers are now forced to pay for setting up electronics waste handling systems. Whereas the ELV regulation has immediate impact, the first round of impact from the WEEE policy is likely not to influence the design of electronics products very much. This is due to the weak lines of communication in this dispersed sector, and also because of the large amount of products already in circulation and still to end up as waste in the coming 5-10 years and more.

The EC has introduced the producer responsibility principle as a new regulatory regime within electronics and cars using the argument that this should also influence the design of products, but there is little evidence that this regime produces this effect (Walls 2006). The institutional complexity of tracing products and the distributed character of both producers (product chains) and the collection of waste products and the handling of these does imply relative high registration and collection costs and blurs the relationship between waste prevention and design responsibilities. With time especially the larger producers of brand consumer products and the producers of professional equipment may have an incentive to change their design strategies and introduce eco-design principles. Whether this can be closely linked to the instruments installed by WEEE is though questionable. In this respect other regulations like the RoHS ban on certain substances and the new regulation on energy consumption and labelling will demonstrate a much more direct impact on design practices.

The innovation potentials of EEE are quite evident and it is therefore important to analyse the role of EEE product design and the interaction with IPP strategies: One main challenge is to address the separation of plastics, as the combination of usually three to ten different plastics in an EEE product produces the worthless amalgam 'gunk' plastic. Other general design strategies are: Avoid lead in

electronics & glass for CRT, avoid bromine in plastics. Develop products that are cheaper to disassemble and easier to break down. Statistics indicate that there is a vast amount of EEE products in limbo e.g. as Cathode Ray Tubes, CRT glass and it is questioned whether industry is prepared to absorb the total amounts of recycled material when widespread collection of end-of-life EEE begins (Monchamp et al 2001). Therefore another future design challenge is for industry to accommodate the new and growing amounts of recycled material.

Life Cycle Assessments of EEE often point to the end-of-life waste disposal as a major environmental impact in the EEE life cycle (Remmen et al 1999). Also cleaner technology projects given support in different national government programs as well as in some of the framework programs of the EU have had a product focus. Until recently however, there was only limited interest in environmental design questions related to the impacts on waste in the EEE sector. While other environmental aspects related to the use phase and the energy consumption has resulted in new innovations. Generally the eco-design perspective has been in focus in cleaner technology programmes as is the case with several projects supported since the mid 1990ies in e.g. the Danish programme giving practical advice for the conscious design of electronic products (see e.g. DEPA 1995; IPU et al 2002).

A general experience has been that data collection as the basis of cleaner technology developments is a laborious and time consuming process due to the complex composition of EEE products. Evaluations point to a lack of 'environmental maturity' in the sector, where alternatives for product and process improvement are available but hardly implemented. There is little interest and slow dissemination of results explained by the lack of request of environmentally friendly products and vice versa. There is a need for further stimulation of the companies in the sector. (DK) 'There is currently a lack of financial drivers to design products with a long life span or to manufacture them in a way that takes into account their future management as waste.' (ACRR 2003)

In contrast to WEEE that is based on the implementation of a regulatory regime different from the traditional command and control systems, the RoHS directive represents a rather traditional and straight forward legal instrument installing a ban on certain substances. RoHS has already shown a tremendous impact not only in Europe but on all producers of electronics products and component who have the slightest interest in exporting to Europe. In this sense this regulation has already demonstrated a high level of penetration and lead to the finalisation of a number of innovations necessary to avoid using the banned substances in components and processes. On the other hand the aim of RoHS is rather narrow with respect to the substances regulated. There is neither engagement nor follow up policy concerning the quite large number of substances in the second rank. They may have almost as big an impact on environment and health but have not received the same attention (yet). In this respect the RoHS directive cannot stand alone but need support from a more conscious design and prioritisation tools to be implemented in electronics design procedures and as standard engineering design knowledge. There may even be a need for following up on this regulation adding other substances to the list.

As much of the results of the waste policies presented in parallel with the WEEE directive is related to the reuse and recycling of materials, the question is whether the reuse will have any significant impact in an area where quite many products are outdated and changed not due to technical wear but due to the fast changes in standard, components, and fashion. It is most likely that the primary target of recycling still will be the metal parts, the precious metals and a few other parts of the products more related to casing, wiring, and cabling while the core electronic components and circuit boards end up in waste streams either for incineration or deposit. Due to the fast development and phasing out of still functional products the reuse possibility is most likely to result in rather combined streams of (non-waste) products channelled to Africa, India and China in a growing grey market of combined exports of products for reuse, waste for recycling, and simple waste. Present control standards are that products have to be at least partly functionable if they are

to qualify as 'products' and thus acceptable for export. However, with increasing turn-over of products (the mean use time of a new mobile phone in Europe is now about one year) it is likely that these criteria can be met quite often. In this case WEEE will have as effect an increasingly organized export of used (but somewhat functional) EEE out of Europe.

Present legislation and especially its practical implementation are insufficient in dealing with the de facto exports and their environmental impacts. The privatisation of the waste handling sector may – following this – introduce a new need for enforcement and control.

6.2.6 Effectiveness of policies and future demands

The question is whether the policies have met the anticipated goals and have been implemented in a productive way. There is not much doubt about the effectiveness of the conventional banning of substances as introduced through RoHS, while the producer responsibility regime in WEEE with its new and specialised institutional setup for the electronics and electrical sector is both costly and opens for a rather diverse and potentially difficult to control waste handling system of its own. This regulatory regime may be useful in certain (few) specialised product areas (sectors) but it does not relieve the local waste collection systems of the need for sorting and efficient handling of the differentiated waste streams. The overall impact of the policy pattern as introduced in the EEE area demonstrate the long term commitment to reductions in the use of heavy metals and other polluting substances and shows the effectiveness of such sustained efforts.

The design issue is currently being addressed by a proposal for an EU Directive on Eco-Design on all energy-using products within EU. This is a proposal for a framework directive which lays down eligibility criteria for adopting implementing measures. As this is only a framework directive implementing measures have to be adopted in order for legal obligations to flow from the framework directive. The directive will provide the possibility to swiftly establish eco-design requirements on the basis of technical and economic analysis. Examples of such requirements which are already existing, are minimum energy efficiency requirements and star rating systems. It is important to avoid market fragmentation through diverging national requirements as regards the environmental aspects of these products. It consequently appears necessary to create a coherent harmonised Community framework in which to address these eco-design requirements.

Legislative action is needed to stimulate adequate integration of environmental considerations by the manufacturers in their design process. Even within large companies, the dissemination and implementation of eco-design in the various departments is often problematic. However self-regulation is not always a feasible option, in particular in sectors where the market is very fragmented. This is relevant for energy-using products, given the size and lack of homogeneity of the sectors involved; it cannot be expected that credible and coherent voluntary actions of the economic operators to address environmental aspects of energy-using products throughout their life cycle will emerge spontaneously (EC 2003). The EEE business chain does for many of the products not include the strong coordinators that the automobile manufacturers are in the ELV chain. While a few large producers of consumer products and similarly some producers of professional equipment may define standards and enforce them upstream in the product chains, the diverse character still requires general standards and requirements to be established. It is not clear who is to actively delegate responsibilities and coordinate the construction of new networks.

An innovative aspect of the present proposal is that it allows the use of environmental management systems which take the product design and environmental performance adequately into account as a method for conformity assessment. Eco-labelled products are presumed to conform to eco-design requirements set in this framework where that requirement is part of the criteria for awarding the label. Changes in consumption behaviour should be stimulated in order to assist consumers in choosing to buy long-life and eco-efficient products and stop using useless ones.

As an alternative to redesigning EEE products, the consumption systems can be redesigned in order to promote dematerialisation by replacing products with services through renting, sharing, pooling, leasing or other arrangements. Product Service Systems are already widespread in the EEE industry e.g. as leasing arrangements for office equipment: PCs, printers, faxes, photocopiers. Xerox has through long terms used the leasing approach as business platform. These arrangements make it possible for the producer to refurbish new machines with 'old' components and thus drastically cut the waste fraction of end-of-life products.

Advice is given to improve policies related to the earlier phases of material streams and where the key is to impact waste generation and its hazardousness. More emphasis must be given to the eco-design aspects of e.g. the IPP policies to make sure that the disassembly of products is made easy and that the products at a rather detailed level are marked for the substances they contain. This could lead to a next generation WEEE improvement with less emphasis on the registration of legal responsibilities to secure cost recovery of the waste handling and make sure the correct payments are made, but to make the reuse and recycling activities easier and to influence more directly the design practices among the distributed set of producers of components and parts. This will also include a larger number of substances that are not as easy targeted by banning policies as in the case of RoHS but should be recognized and listed for concerned use in the design of products.

6.3 PVC regulations based on recycling and substitution

Several materials and especially specific substances have been regulated due to their hazardous impact on peoples' health or the environment. For some substances this type of policy already has a rather long history as is the case of e.g. lead and cadmium. With the growing awareness of the amounts of waste becoming a major threat to society as the hazardousness elements in the waste certain materials have been targeted as contributors to environmental and health problems arising from the waste itself. With the emphasis on specific products contributing to the negative impacts, policies for substitution of problematic materials and substances has become more and more important as an element of waste related policies and as an element in other policies e.g. targeting products contributing to problematic waste streams. A number of innovation programs created in several countries in Europe have been supporting the development of cleaner technologies especially as in the case of the Danish programs targeting the substitution of materials including PVC. These policies from the 1990ies have in the new millennium been followed by policies focussing broader also on products like the case of the IPP policy. The perspective of substituting problematic and dangerous substances and materials is also at the core of the new regulation of chemical substances in the REACH-directive put forward by the EU and to be implemented from 2007.

One of the illustrative cases of materials focussed policies has been the treatment of the plastics resin PVC. This case also demonstrate the difficulties in handling sustainability issues where the different interests of actors resulting in contradictory views of the role and impact of a specific material backed by a large number of established uses and strong industry interests. In balancing economic interests, environmental impact, health threats and social impacts the environment often turns out to be the looser, especially if the complexity of the sectors involved is backed by contradictory interests and therefore a need for policy interventions to provide change.

The PVC case also demonstrates the importance of the specific forms of waste handling and consequently how different waste handling technologies themselves are contributing to the constitution of the environmental and health problems in question and how these are assessed and prioritised. Incineration of waste which e.g. is the dominant form of waste treatment in Denmark poses a much more direct problem in the treatment of PVC than the deposit on landfills due to the hereby freed chloride. Whether the PVC material itself or the use of needed additives providing the

material with its specific attributes is seen as the main environmental problem is heavily dependent on the technologies employed in the different life cycles and treatments of the many types of products in which PVC is used.

In contrast to the more than 20 years of debate and attempts to limit the use of PVC in a number of sectors or to create efficient recycling procedures results are meagre. In fact in certain sectors the use of PVC is even growing, and in sectors, where the use has shown to cause health problems as in e.g. toys and medical utensils, the substitution is going quite slowly even though alternative products and materials have been present for quite some time. The only field where reductions have been remarkable is in packaging materials while the use of PVC free cables is getting to a turning point. Even though a number of different policy instruments have been employed, the synergy of these has been limited countering the general expectation that the combination and coordination of different policy measures in most cases will demonstrate the greatest impact. In the case of PVC regulations the lack of or uncertainty around an overall and prioritised policy goal has been crucial. An important element in the employed policies is the use of voluntary agreements established with the PVC industry and a number of PVC using sectors. These policies have been targeting changes in the use of additives and have been concerned with creating procedures for reuse and handling of used PVC. Partly due to resistance from industry and partly due to the lack of clear goals the use of voluntary agreements has not generally proven to be successful – even though targets were low – in reducing the amounts of PVC used and entering the waste streams.

6.3.1 Material flows in production, use and discarding of PVC products

PVC was invented already in the early 20th century and became an industrial product of some importance from around 1950ies and onwards. The plastic has shown to be a very generally useful material, and is even rather inexpensive compared to a number of other types of plastic relevant for the same types of uses. PVC has been used both for products where strength and durability is a main feature and for products where flexibility in conjunction with chemical resistance and strength is the main need. An overview over products would among others include pipes for industry and for usage in water systems and sewers, window frames, doors and floors in buildings, toys, cables for power and electronics, casings for PC's and other products for both household and industry, packaging materials and folios often used also in the food sector, medical utensils like bottles, bags and pipes, containers for storage of acids, and raincoats, boots and gears for protection and daily use.

The production of the PVC resin is based on chemical processes that include the use of chlorine, which makes these processes risky and potential hazardous. Also the use stage poses problems, due to the evaporation of certain additives used especially in flexible (soft) PVC. Furthermore there are problems in the waste handling stage. The character of these problems depends on the type of waste handling as earlier mentioned. The reason for PVC to be a popular material in industry is for one part its multifunctional use, durability, and resistance to chemicals, for the other part the resin is rather cheap to produce as its basic components are easy available. PVC is produced by a synthesis of chlorine and ethylene produced from oil. The monomer vinyl chloride is polymerised into PVC, which, however, also contains residues of the carcinogenic monomer. In the final product 57% of the materials weight is chlorine. The chlorine is a by-product (some would argue a co-product) from the production of (liquid) caustic soda (or sodium hydroxide) which is one of the most commonly used chemicals as a neutralizing agent, in soap production, for bleaching and in textiles treatment, in pulp and paper production, in aluminium production etc. Approximately 40% of all produced chlorine is used for the production of PVC, or to phrase the problem differently: without PVC production the surplus of chlorine would become a major obstacle to the chemical industry (EC 2003) The industry is also facing other problems as some of the older processes used in the production of chlorine involves use of mercury that is one of the most hazardous heavy metals to be banned from production use.

For specific uses PVC has to be added stabilisers against deterioration by heat and ultraviolet light that otherwise would result in freeing chloride from the resin which especially is relevant for the PVC's used in building construction materials and in cables, where lead based stabilisers account for more than 70%. The use of PVC in packaging materials, toys, and hospital equipment is based on the flexibility of the material obtained by adding plasticizers of which the phthalates is most used type covering more than 90% today. A third group of additives are the flame retardants added to restraining the burning of PVC. These additives pose separate threats to the environment and for some uses of the material also throughout the use phase, as they often are slowly evaporating from the material.

The reason for PVC to change its status from being one of the core inventions of a multiuse plastics material coming from the chemical industry to becoming a potential threat to health and environment has been closely related to the materials decomposition in certain waste treatment processes. The chemical industry has been objecting to regulations banning PVC from certain uses and has argued that the problem 'only' was a result of wrong treatment strategies, but the controversies have continued. While no real compromise or solution has been found it is relevant to look into this area of waste regulations due to the dramatic disagreements concerning the viability of the material and the attempts to be put on the list of materials to be phased out completely or at least in relation to certain uses (Jørgensen & Høier 1995; IDA 2003).

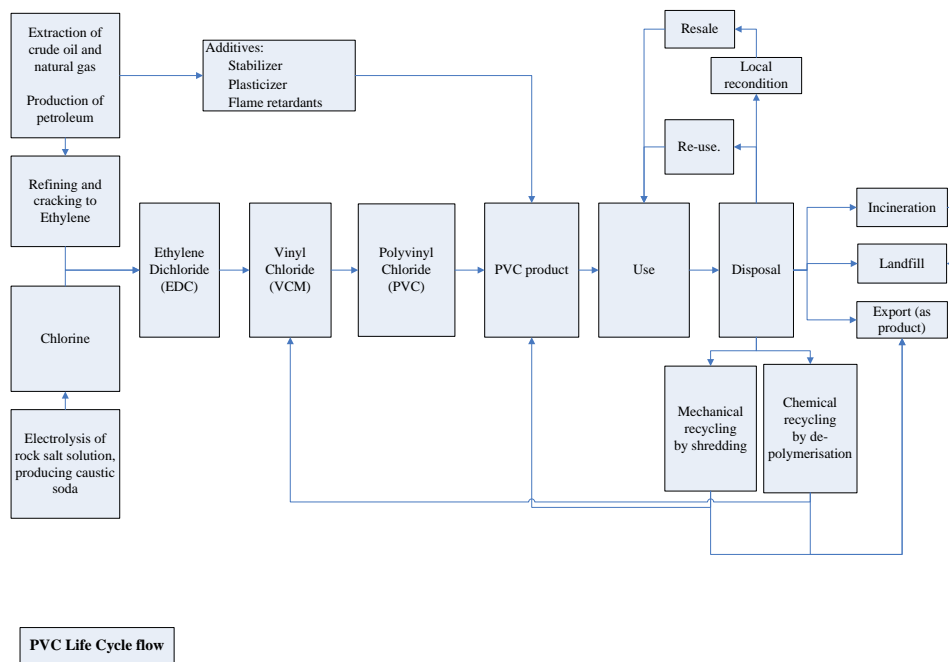

Figure 6.2: Materials flow and products for PVC

Due to the fact that PVC is used in a wide range of applications difficult to separate, data on PVC waste arising in the EU are uncertain. The most recent and detailed data available on PVC waste quantities are estimations carried out by industry and are based on calculations using production quantities per year and average lifespan of products.

It is estimated that in 1999 the total annual PVC waste quantity was about 4.1 million tonnes in the European Community, which can be divided into 3.6 million tonnes of post-consumer PVC waste and 0.5 million tonnes of pre-consumer PVC waste. Pre-consumer wastes are generated during the production of intermediate and final PVC products as well as during the handling and installation of PVC products. The present composition of PVC waste is two thirds flexible PVC and one third rigid (hard) PVC mostly used in building construction components. About one million tonnes of PVC is present in the construction and demolition waste stream. The PVC consumption at a World scale is about 20% of all plastics, and the total amount of PVC may be around 26 million tonnes a year.

One million tonnes of PVC can be found in the municipal solid waste stream, which comprise of waste collected from households as well as similar wastes collected from commercial and industrial operations. This is containing both soft and hard PVC, but is often difficult to separate as much of it comes from smaller products (often with limited life time) and packaging materials. About 700,000 tonnes of PVC packaging waste are generated and about 700,000 tonnes of PVC are found in end of life vehicles and electrical and electronic equipment. The total employment in Europe related to the production of PVC is approximately 20.000 people, while almost ½ million people are involved in productions applying PVC. Out of these numbers quite a large part easily would switch to work with substitute plastics and other materials, if regulations were tightened, as these are often used in parallel to PVC.

At present the main waste management route in the Community for all types of post-consumer waste is landfills. This is therefore also the case for post-consumer PVC waste. About 2.6 to 2.9 million tonnes of PVC waste are currently deposited every year. Mechanical recycling is applied to only a small fraction of the post-consumer waste (about 100,000 tonnes). Countries like Denmark and other Nordic countries are to a high degree regaining energy from wastes by incineration used for heating and co-generation, which is supported by the amount of energy resulting from burning PVC. But much of the waste PVC demands acid neutralising systems based on adding chalk to the process and almost doubling the rest products (slag) from PVC compared to its own weight. Approximately 600,000 tonnes of PVC are incinerated per year in the Community. This also illustrates the rather different focus and approaches taken by the different countries in the Community dependent on their dominant waste handling practices.

6.3.2 Environmental objects, their constitution and impacts

The first problems with PVC in the waste streams were related to free chlorine coming from decomposition especially through incineration. The process resulted in the synthesis of acid and dioxin due to the uncontrolled free chlorine and was already recognized in the mid 1970ies. After the Seveso accident in Italy more public attention was given to the impact of dioxin because of its accumulation in the food chain ending up in e.g. milk and bringing the so called 'blue babies' to the newspapers front pages. For a period of time dioxin became a first priority as the most important object of environmental discussions. In Denmark and followed by other countries in Europe a discussion arose about banning PVC as such due to the diffuse problems with the waste streams. Soon after other problems came up due to the environmental and health impacts of stabilisers used in hard PVC, plasticizers used to make PVC flexible, and flame retardants to make PVC resist fires. The attempts to impose rather strong regulations on PVC inspired the plastics industry launch a quite broad and continued activity lobbying for the qualities of PVC and for more selective types of regulation including the promotion of voluntary schemes of take-back options and reuse strategies.

The most important environmental aspects include risks in the production phase, the environmental impacts of additives like lead, cadmium, and phthalates during use of products and in the waste stream, the generation of acids in case of fire, the generation of dioxin and acid during incineration. The role of the different environmental and health related impacts of PVC are quite dependent on

the use and treatment of PVC in the use phase as well as in the waste streams. One of the big problems in handling PVC in the waste stream is the rather diffuse use of PVC in numerous numbers of household products, in cloth and bags as well as in toys and food packaging. While the handling of hard PVC and even cables have been argued to be controllable by industry by sorting the waste stream and reuse or recycling, though not verified in the percentage of recovered even if the copper and other metals make the recycling of cables a profitable business.

The use of phthalates and other substances as plasticizers is not a very stable solution as they are constantly evaporating from the flexible PVC and are easily entering living organisms where they can cause cancer and hormone disturbances. Of these plasticizers the phthalates are dominating with around 93% of the total use. Even though this has been known for decades flexible PVC has been used for food packaging, toys – even for small children, and for medical utensils. In the Danish cleaner product innovation programs the substitution of PVC has been given attention and for almost all uses alternative plastic materials have been developed. But these innovations have not received as much attention in other countries partly due to a different prioritisation and awareness of the problems related to the handling of the PVC waste fractions in ordinary household waste.

The use of PVC in the building sector with stabilisers based on heavy metals like lead and cadmium has resulted in rather complex issues in relation to the environmental impact and risks related to the extensive potentials for use. The most used stabilisers include lead covering around 70% of all stabilisers. The use of flame retardants is also important for making PVC useful in e.g. cables and electronic equipment. But this does not eliminate the specific problems related to the consequences of even small fires, which has resulted in the development of substitute materials. The background for this is that a fire in cables and equipment produced with PVC leads to acid fumes that in many cases are more destructive in connection with the water used to extinguish the fire than the fire itself because the acid fumes destroys other installations.

As a consequence of the future ban on lead and cadmium in most products also hard PVC has become a problem as recycling in many years will make old PVC products containing heavy metal stabilisers a problem (EC 2000a). An estimate of the life span show that these parts of the PVC uses on average last more than 35 years (Griffiths 2006). Also reuse has hitherto had little support from an environmental perspective due to the accumulation and distribution of e.g. heavy metals. These problems have resulted in a search for other ways of treating PVC for recycling based on e.g. decomposing the material into its original parts and extracting the heavy metal and other additives from the material.

6.3.3 LCA assessments on PVC

A relatively new study commissioned by the European Commission (Baitz et al, 2004) identified approximately 100 LCAs related to PVC of which approx. 30 included a comparison at the application level. The 30 studies were critically reviewed and the results compiled into the report. An important finding was that LCA comparisons should be made at application level rather than material level because they are more comprehensive and draw a more complete picture of the environmental impact in the life cycle. Important impacts of the material production, use, disposal and recycling should be included. This means that it may be necessary to perform a more detailed mapping of the different uses of a material a specific waste prevention action may affect in order to examine the possible impacts of the use stage. This finding is of a more general nature and may not only be relevant for the PVC case.

The life cycle of PVC has been illustrated in figure 6.2. The overall findings that could be generalised from the review can be divided into the three life cycle stages production, use and end of life (Baitz et al, 2004).

6.3.3.1 Production

The review of life cycle assessments finds that the production stage of PVC has a considerable contribution to environmental impacts in the life cycle. Especially the production of the vinylchloride monomer and its precursors chlorine and ethylene contributes significantly. Ethylene production requires most of the primary energy (2/3) and also has the highest contribution to VOC emissions. From a life cycle perspective, the production of stabilisers and plasticizers also play a relevant role. The production processes of these additives have improved through better energy efficiency and the reduction of process related emissions during the synthesis of the products. This may lead to a significant optimisation of the performance of PVC over its life cycle. Fillers have a rather low contribution to the overall impact. Also the emissions and energy consumption during PVC compounding are relatively low. PVC processing has a rather low impact, due to its simplicity. Furthermore, pigments offer a comparatively low optimisation potential from the view point of LCA. The amount of pigment used in PVC compounds is low; therefore the potential influence on an optimisation is low as well.

6.3.3.2 Use stage

For the use stage it can be concluded that PVC products are highly durable; durable products are potentially replaced less frequently which usually will have a positive influence on the PVC life cycle. Additionally, PVC material requires little maintenance and repair due to its chemical, mechanical and thermal properties. This also has a positive influence on the environmental performance of the life cycle. Emissions of plasticisers cannot be handled very well in LCA and their impact does therefore not show. Nevertheless, these emissions are generally considered to be of importance for the health and environmental profile of PVC. Due to PVC's comparatively low density, and the ease with which its mechanical properties can be altered, its potential to serve in light-weight applications is considerably higher than that of its competing materials of a higher density. The potential to improve product life cycle impacts in lightweight applications is especially high for mobile applications (like cars or other means of transportation).

6.3.3.3 End of life

Four primary options for end-of-life PVC treatment exist: Land filling, thermal treatment (with energy recovery), chemical recycling (most material recovery), and mechanical recycling. In terms of the life cycle, the end-of-life stage plays an important role. This importance is not primarily due to environmental impacts of the treatment or recycling processes; compared to resource extraction, energy generation and production processes, the end-of-life processes have more often than not lower environmental impacts. The importance is due to the different type and quality of recovered materials and energy, which are substituting different production steps of virgin or primary materials and energy according to their specific quality. Hence the more production steps that are substituted, the better the environmental improvement will be. Therefore material recycling not only saves resources, but saves many production and transport steps and their respective environmental impacts too.

In the end of life of PVC products the only possible advantage of land filling would be the simple technical operation. The main drawbacks besides (long-term) emissions to air, water and soil, are the limited amount of available landfill volumes, no secondary product output and no (or negligible) recovery of energy or resources. PVC products are a source of phthalic and organotin compounds in landfills, but contribute little to the inventory of heavy metals. Further, the effect on the quality of the leachate seems to be rather small.

On the other hand the main advantage of incineration is the reduction of waste masses and the separation into different fractions, while being able to process mixed waste fractions. Modern incinerators yield not only electricity and heat but also hydrochloric acid and metals as valuable recovered products. The main disadvantages from a life cycle point of view are the high generation of hazardous waste (mainly ashes) that have to be disposed of accordingly and relatively energy

demanding flue gas treatment processes. Further, it is not possible to directly gain secondary material, but only intermediate products. Important are a proper flue gas treatment and an adequate fate of the residual ashes. Therefore most importantly, parts of the energy production chain can be substituted by the products of incineration.

Feedstock recycling has the main advantage of being able to separate different contents of substances (elimination of undesired substances or concentration of valuable substances). Therefore different outputs (e.g. organic intermediates, coke, lead, salts) can be gained according to the specific demand situation for secondary recovered products. Further, the feedstock technologies can usually cope with a certain variation in the input. A variation in the input composition leads – in most cases – to a variation in the distribution of the output (the secondary feedstock). The main disadvantage from a life cycle point of view is the decomposition of the initial material, which makes it impossible to directly gain secondary material, but at least the production chain from resources to the chemical intermediates can be substituted by the products of feedstock recycling.

The main advantage of mechanical or material recycling is the direct gain of secondary polymer material, which can potentially be re-used in comparable applications. Therefore material recycling can substitute the largest share of the polymer production chain – from resource extraction to the granulation process. The main disadvantage of mechanical or material recycling is the dependency on a relatively stable input composition because the quality of the recycled product is particularly vulnerable to input impurities. Consequently, mixed wastes can seldom be processed.

Studies of the costs involved in depositing, and chemical treatment have recently been undertaken and demonstrate that the cost analysis does not provide an answer to the choice of PVC waste policy. The costs are almost equal for depositing and incineration while higher for chemical treatment, so the choice of waste handling method is dependent on the other conditions given for waste selection and practices on one hand and the willingness to avoid the future risks from the leaching of phthalates and other additives.

6.3.4 Policies influencing innovation, environment and waste

Innovations in relation to the production, use and handling of PVC as waste especially seen from the perspective of waste prevention and minimization of hazardous substances can be found in the following areas: substitution of PVC by other plastics or materials, substitution of the stabilisers and plasticizers used in specific types of PVC, recycling of PVC using mechanical and thermal processes, decomposition of PVC into basic substances or into ingredients to be used in new PVC, improvements in incineration processes and in removing acid from the smoke, and control of landfills to limit pollution. Innovations have surfaced in all these areas which demonstrate the continued focus and need to find alternative solution to the still basically unsolved problems. Unfortunately the partly unregulated situation has also resulted in exports of used PVC where questions can be raised whether the term 'reuse' can be applied undoubtedly.

Especially while the potential threat of a general ban on PVC or more selective regulations of the use of PVC for certain types of products quite a number of cleaner technology projects were launched resulting in finding alternative plastic materials for almost all uses of flexible PVC and for the uses of PVC for e.g. water supply systems. Substitutes were found in e.g. the Danish cleaner technology programs and innovations carried in industry for most of the applications having immediate health impacts like fresh water pipes, almost all medical utensils though not for flexible tubes, for use in electronics and power cables, and even for most toys for small children. But while products using the alternative materials are developed and produced, the marketing of these products lack behind as little awareness among customers and in green purchasing policies still prevail due to the unclear policies concerning PVC. Replacements were also found for the use of PVC for packaging materials including food packaging and beverage bottles. Other products like

artificial leather and boots and coats used as protection against aggressive chemicals turned out to be more difficult, but still the majority of PVC could be substituted by other materials.

The development of PVC-free cables has been a successful innovation promoted by NKT in Denmark from the mid 1990ies but a little more expensive leading to a slow market uptake of the new types of cables. The introduction of a PVC-charge in 2000 in Denmark helped making the alternatives more competitive. But still today many cables are produced using PVC.

Search for alternative additives to substitute lead and phthalates have also been initiated but first lately some results seem to come out of these endeavours leading to possible new types of additives. In this case the PVC industry has been the active and driving part, and questions can be raised to why these innovations have been so long under way. A recent innovation has been introduced by a Danisco subsidiary company named Soft-N-Safe which can substitute phthalates as plasticizers. The product is 3-4 times more expensive than the phthalates, but is biologically decomposable which has led the European Food Safety Agency (EFSA) to accept it for sales in Europe and even for use in food packaging materials.

Though reuse has been seriously considered certain limitations have showed due to the degeneration of PVC's over time. Few cases though have been seen where PVC is used for as a secondary filler material accepted as reuse in e.g. noise shielding plates. Following the rather limited options for reuse recycling of PVC has been in focus. Several processes have been analysed, developed, and tested. The focus here has been on either mechanical processes or chemical feedstock processes.

Mechanical processes cover cleaning, shredding, and reusing the plastic after some treatment together with new PVC resin. Several innovation projects have been focusing on the recycling of PVC where especially the Solvay VinyLoop process has reached a level of functional implementation with a recycling factory build in 2002 in Ferrara in Italy handling 300.000 tons and a quite new factory established recently in Japan projected to handle 1 million tons of cable insulation scrap. In the case of mechanical processes one of the major problems has been the accumulation of the added stabilisers and the content of heavy metals – especially cadmium – that is supposed to be eliminated from new products due to recent EU regulations. Other tests have demonstrated the possibility of recycling hard PVC pipes up to five times without losing product quality.

Feedstock processes based on chemical treatment of the used PVC and decomposing it into some of the basic substances in the material has been another focal point in the development of handling of waste PVC. Two of these processes have been developed with support from the Danish EPA based on thermal hydrolysis at moderate temperatures resulting in decomposition of the PVC and even separating the heavy metal component from the substances. Most importantly the chlorine is regained and made into plain salt (NaCl). The projects have also received some attention and support from the EU level, bringing them to the level of demonstration projects where technologies can be tested in close to full scale processes. One of the technologies – the Watech process – has been developed by NKT in Denmark and was in 2003 taken over by the waste company RGS90, who also has been responsible for the other process. The processes have though faced some technical problems but also difficulties with getting enough used PVC to make the process efficient at an industrial scale.

Waste handling procedures based on source segregation to avoid PVC in waste streams for incineration have been established but estimates show that not more than 50% seem to be separated from the waste streams due to the varied and widespread use of PVC (Miljøstyrelsen 2005).

Partly based on the controversies and the continued pressure several studies have been issued on economic comparisons of different separation, recycling, and waste treatment technologies. At the EC level several studies were issued in 2000 where the focus was on the choice between incineration, depositing, and recycling concluding, that deposits and recycling were the most beneficial options, but not taking into account the practical barriers for an effective separation of the waste stream (Brown et al 2000). The Danish Environment Protection Agency has recently carried out such an evaluation. It involves the comparison of different competing treatment technologies including incineration, depositing, and increased sorting of PVC waste for recycling. The analysis is yet not published, but the process of constructing this analysis demonstrates the complexities and difficulties of producing reliable economic evaluations of this kind.

A part of this discussion has been focussed on countering the worries about the leaking of e.g. additives and monomer vinyl chlorides from deposited PVC on land fills, but without substantiated evidence for the long term perspective. As deposits of PVC will only grow this alternative face certain limitations.

Following the identified threats from the additives in PVC the Commission has decided on a temporary ban of certain phthalate-based plasticizers in certain children's toys and items. This ban has been prolonged several times due to lack of an overall policy framework for the regulation of PVC. What has not happened is a systematic ban of the use of these plasticizers for flexible PVC even though most products can be produced with alternative materials. As a consequence of the focus on heavy metals the use of these materials for stabilisers will be banned in the near future. In e.g. Denmark cadmium has been banned already since 1993.

The Czech Republic passed in 1997 legislation to ban PVC packaging from January 2001 - the first legislation of its kind in the world. This Law has been found breaking the rules of the single market. Thus in 2000 the law has been changed and according to the new version the ban will be in effect from January 2008 (Arnika Association, 2004).

6.3.5 Policy impacts - patterns and regimes at play

Several policies have been suggested for the regulation of PVC usage and waste handling during the last more than 10 years, but no final conclusions have been reached. While the impact – or maybe more correctly – the lack of impact from the policies related to PVC can be studied over a longer time span also the contradictions and conflicts between installed policies and countermeasures and promised changes from industry end in a lack of consistency and thereby a indecisive policy pattern.

Industry's role in the field of PVC policies has been quite important from the very beginning and is still very important and contributing to the continued lack of overall priorities. Several interest groups and lobby organisations have been founded to support the usefulness – in the eyes of industry – of PVC as a multipurpose material. Though the EU in 2000 published a Green Paper (EC 2000a) on the strategies and priorities on PVC, which was supported by the European Parliament in 2001, an overall policy is still in the waiting. Meanwhile the PVC industry and its subbranches are promoting voluntary approaches to handling the environmental problems of PVC. The measures presented and the control mechanisms a rather weak, though, emphasising e.g. the phasing out of lead based stabilizers not before 2015 and a recycling ratio of 25% (Griffiths 2006). On the policy level this unfortunately supports the general picture, that voluntary agreements only produce significant results when supported by clear goals and targeted policies from the government side (de Bruijn & Norbert Boehm 2005).

Several policy measures have been based on information and purchasing policies using rather weak tools primarily hoping for some customer and market influence on the producers of PVC products.

The first outcomes of these policies have been publications about buying PVC free products and e.g. the 'PVC alternatives database' set up by Greenpeace. There are though examples of some market based instruments using charges to support alternatives to PVC in the case of PVC-free cables, but these have remained national regulations even though they are effective in influencing the choice of products in the market.

The policies and often also lack of policies has resulted in a number of different innovations of which some has lead to the development of substitution materials, others to end-of-pipe improvements of incineration facilities to handle the acids resulting from burning PVC as part of waste, technologies to decompose PVC, and stabilisers without heavy metals and plasticizers based on biodegradable substances. Many of these innovations have been the result of companies attempt to prepare for eventual stronger regulation, but many have not been brought to the market as the regulatory conditions surrounding PVC has remained unclear and changing.

The overall picture of the policy impacts shows a rather complex pattern with no simple answers to be given on the impact of the policies employed. The controversies around and about PVC are a rather good illustration of some of the consequences of contradictory stakeholder interest for policy formation. The lack of an overall objective and sustained efforts to reduce the use of PVC in the environmentally most problematic areas has left the materials regulation of PVC in the limbo – a state where it is unclear whether the material will be banned for specific uses or again accepted in general. The result has been that no conclusion has been made about which types of regulation to set up. In fact even in the cases were well documented health issues were pushing for regulation the Commission has only banned the use of certain plasticizers on a temporary basis, and first in 200x the use of heavy metal based stabilisers were finally banned.

This situation has on one hand been an annoyance to the plastics industry on the other hand it has kept the industry alive and growing, and in the last year even new attempts are made to promote PVC as the multipurpose plastic through web-sites, campaigns, and lobby activities. At the same time industry's own preferred use of voluntary recycling schemes for PVC's have only showed slow progress and result in recycling of less than 15% of the PVC in the waste stream (Danish Government 2004). This has demonstrated that voluntary agreements not always are working well and in this case lack the overall commitment both of industry and of government to reach the targets. While in some cases voluntary agreements set up on the basis of a potential demanding regulation might be effective, while the lack of serious government intervention leads to the opposite (deBruijn & Boehm 2005).

6.3.6 Effectiveness of policies and future demands

The focus on PVC came out of heated controversy about avoiding dioxin and other impacts of plastics and here especially PVC due to the high content of chlorine typically released by incineration and the leaching of additives in long term processes. Initial attempt to ban or reduce the use of PVC by government interventions was heavily opposed by the PVC industry and its suppliers of especially the chlorine. The alternatives presented by industry have been voluntary measures to improve the processing and the reuse of PVC.

The focus on the problems with PVC resulted in a number of cleaner technology supported innovations of substitute plastics materials and products for several of the most critical uses of PVC in medical utensils, fresh water pipes, toys, food packaging, cables etc. Parallel to this process a growing awareness also on the health and environmental damages coming from the additives used as stabilisers, plasticizers and flame retardants came in focus.

The life cycle assessments show that the production stage of PVC contributes most to the potential environmental impact. Therefore options for the end of life of PVC that results in secondary

materials as close to PVC as possible are the environmentally best. Although energy recovery in incineration will save some other energy fuels it does not seem to be a very good solution environmentally speaking since the calorific value of PVC is rather low due to the high content of chlorine and because of the amounts of hazardous waste generated in flue gas cleaning. Landfill is not an optimal solution either. Analysis of the economics involved in these two waste handling techniques show almost equal costs while alternate chemical decomposition are dependent on the willingness to avoid the risk of future leakages from depositing the PVC or the remains from the incineration process. The main drawbacks besides (long-term) emissions to air, water and soil, are the limited amount of available landfill volumes, no secondary product output and no (or negligible) recovery of energy or resources. Therefore waste prevention activities for PVC should focus on substitution and increasing reuse to avoid landfill and incineration of PVC.

Though many projects have been carried out to resolve the environmental problems and economic costs of using PVC and alternatives, no clear answers have been produced due to the diverse interests represented and the continued focus on possible policy alternatives. Even though the health issues themselves could have lead to a clear strategy of phasing out or banning the use of PVC in a number of areas, only temporary policies have been installed on e.g. the banning of phthalates. Recently the RoHS directive will have some impact on the use of lead in stabilisers as well a bromide based flame retardants.

Industry's emphasis on reuse has been hampered by the used heavy metal based additives in the PVC especially for building construction components, which has limited and will the reuse potential still also being only a smaller part of the PVC produced. Due to the long life time of these products reuse will be problematic for many years into the future, as average life times are considered to be around 35 years.

The focus on the environmental and health impacts of the additives has lead to recent innovations in alternative additives that potentially can reduce these impacts and in the future may result in reuse potentials for especially the re-collectable hard PVCs used in building materials and in certain large institutions like hospitals. This does not solve the problems of the distributed use of PVC in other products where the chlorine content also poses a problem and the sorting of waste has limitations.

Innovations have lately been made in decomposition of the PVC material into recyclable chemical components, but these processes still need further testing and demonstration and though they could be a relevant alternative to the problematic strategy of re-use they are not identified as waste prevention though proven more environmentally sound, as the re-use strategy is leading to uncontrollable exports of PVC materials and parts.

The overall policy pattern in this area can be characterised as conflict ridden, and demonstrates a lack of consistent measures and objectives. This is due to the rather concentrated and strong industry interests in the field and the continued reliance on weak voluntary approaches to re-using the PVC. Though quite substantive improvements have come from innovations both concerning substitutions, additives and decomposition of PVC the lack of sustained policy efforts have not pointed to any clear and useful path of development and has left even obvious problems needing regulation unsolved. The lesson learned is that such controversies at the end lead both to a lack of clarity in which actions are to be preferred and also a lack of policy initiatives.

6.4 Textiles – design and use of textiles

This case focuses on the interaction between waste minimisation and innovation in relation to textiles and clothing, which includes garments and household textiles, like carpets. Footwear is not included. The aim of the case is to present the overall challenges to waste minimisation in the textile sector and especially the interaction between waste minimisation and innovation in relation to

textiles through an analysis of a number of initiatives. The case demonstrates one example from the varied area of growing wastes from consumption, where the pollution from wastes are distributed along the production chain and prevention policies must focus not only on design and reuse but also on the patterns of consumption as developed in consumer markets. The case is first and foremost a qualitative description of the interaction between waste prevention and innovation.

6.4.1 Material flows and waste generation related to textiles

The textile and clothing industry is a very distributed and heterogeneous industrial sector. The textile and clothing chain is composed of a wide number of sub-sectors covering the entire production cycle from the production of raw materials (fibres) to semi-processed (yarn, woven and knitted fabrics with their finishing processes) and final/consumer products (carpets, home textiles, clothing and industrial use (technical textiles)). In 1999 the world production of fibres was 55% synthetics and 37% cotton and then 5% celluloses and 3% wool. Around 9 % of the fibre production took place in EU-15 with around 70% of the production as synthetic fibres. The EU-15 consumption of fibres was at that time around 2/3 higher than the production of fibres. 47% was used for clothes (apparel), 32% for home furnishing and 21% for industrial uses (EU-ecolabel, 2002). The import of textiles was 23% and of clothing 46% (Walters et al, 2005). In 2000 the EU textile and clothing industry represented 3.4% of the EU manufacturing industry's turnover, 3.8% of the added value and 6.9% of the industrial development (IPPC, 2003).

Until 2005 textile and clothing was, as the only major manufacturing sector, subject to intensive use of quotas, which limited the export from certain countries, including China, to the US and EU. The cancellation in 2005 was part of the ATC-agreement (Agreement on Textile and Clothing) negotiated via WTO. The cancellation has implied a huge increase in the import from China to the US (200%) and the EU (90%) and a decrease in the manufacturing in the US and the EU and in a number of developing countries. These changes were followed by a special transition agreement between the EU and China, which limits the increase in Chinese exports. The US imposed new quotas, also limiting the Chinese export (Promoting..., 2005).

Like for other products the waste creation takes place in all parts of the life cycle of a piece of textile from fibre production in agriculture (including natural fibres like cotton, wool and hemp) and chemical industry (including synthetic fibres from plants e.g. viscose or from oil and gas like polyester, polyamide etc.) to the discarding after use in households, professional use etc. For textiles, like for other products, it is important to look at the amount of the waste and to the type of waste, including whether the waste is organic waste or hazardous waste. The amount of waste is related to the waste creation in the different parts of the life cycle per unit of product and to the amounts of products. This implies that the total amount of waste should be seen as a multiply of the amount of products and the relative amount of waste per product. Furthermore the amount of waste could be related to the consumption per person per year. All in all this implies that the amount and type of waste can be related to:

- the impact of cleaner production in the life cycle based on substitution of chemicals, reduction of the amounts of hazardous chemicals etc.
- the impact of the changing fashion on the amount of textiles which the consumer has (the stock of textiles) and on the speed of discarding of textiles (the flow of textiles through the household).

The role and impact of cleaner production is related to the global structure of the sector. The outsourcing of a substantial part of the manufacturing of textiles from textile industry in Northern and Western Europe to especially Southern and Eastern Europe and Asia has in general implied a reduction of the level of environmental protection in textile manufacturing and implied, among others, an increase in the amount and hazardousness of waste. There seems to be differences in the level of environmental concern and management in different segments of the textile sector. Some

companies set demands to their suppliers in other countries, while other companies do not set such demands. The demands of the domestic, national environmental authorities are limited in a number of the countries whereto the manufacturing has been outsourced, which implies that environmental demands often seem to be customer-driven. This implies that the level of environmental management in the textile industry in the countries with textile manufacturing differs quite a lot. It looks like the industry in these countries could be divided into three parts: A) A part with the highest level of environmental protection due to environmental demands from Western customers, B) A part with medium level of protection which is not met with environmental demands from their Western customers, and C) The part of the industry, which primarily is serving the domestic markets and practices the lowest level of environmental protection (see for example (Robins & Roberts (eds.) 1997).

The consumption of textiles in the Western countries has been increasing since the 1960'ies. Behrendt et al (2003) reports an increasing amount of new clothing sales in Germany (figures are from the mid 1990'ies): 6 kg per inhabitant per year and 30 items per inhabitant per year. Røpke (2000) reports, based on data from John Hille from Idébanken in Norway, an increasing amount of new sales of garments and footwear in Norway. The amount of garments (like trousers and shirts, but excluding for example underwear) has increased from 7 items in 1960 to 17 items in 1996 and the number of new shoes from 2 pairs in 1960 to 4 pairs in 1996. Hille (1995) mentions a consumption of textiles and footwear (new sales) in Norway of around 50,000 tonnes, equalising around 12 kg per inhabitant per year.

The geographical distribution and dynamics of the waste streams are very complex due to the global structure of the sector. In order to illustrate this, the following paragraphs describe the international role of the textile sectors in Denmark and Thailand.

An increasing part of the products sold in an industrialised country like Denmark is manufactured in developing or newly industrialised countries. Furthermore an increasing part of the products exported from Denmark have in different extent been manufactured in developing or newly industrialised countries, while design and distribution still take place in Denmark (Stranddorf et al, 2002). This development is also seen from the fact that the employment in the Danish textile and garment sector decreased with around 40% during the 1990'ies (About the textile and garment branch 2001) and a similar decrease was seen for the total European industry (Walters et al, 2005). Around 2/3 of the Danish export is clothes and the remaining 1/3 textiles, which covers a number of different products like medical textiles, interior textiles (including carpets) and fabrics. The main export countries are Western countries like Germany (20%), Sweden (16%) and Norway (11%) with clothes as the main part. However, around 25% of the export to Germany is textiles, including fabrics for industrial use like in the car industry. The main import countries are China (21%), Germany (12%), Turkey (12%) and Italy (8%). The import from Germany is a mixture of textiles and clothes and from China and Turkey primarily clothes (between 80 and 90% of the import from those countries) (Danish Textile & Clothing Exports, 2006) - due to the lower wages in these countries

A country like Thailand has another role in the international structure of the sector. Around 2/3 of the Thai textile export is garments and around 1/3 semi-manufactured materials like yarn and fabric for further manufacturing in other countries. The main export markets are U.S.A., Japan, U.K., Hong Kong and United Arab Emirates (U.A.E.) with U.S.A. covering almost 40% of the export with garment as the dominating part, while the export to Hong Kong and U.A.E. seems mostly to be materials for further manufacturing (Thai Textile Export 2003). The Thai clothing export to the US increased 12% from 2004 to 2005 (like the increase in the total US clothing import). The increase in import from China was 63%, while it decreased significantly from South Korea, Hong Kong, Taiwan and Mauritius (ILO, 2005).

Figure 6.3 gives an overview of types of processes and wastes in the life cycles of textiles. The figure and the table are not focusing on a specific type of textiles. The order of some of the processes differs, for example depending on the sequence of dyeing and sewing.

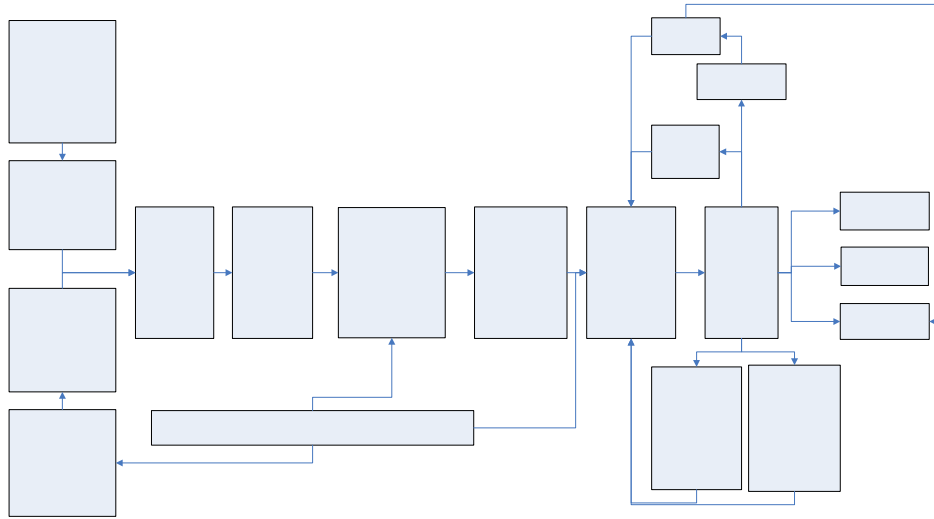

Figure 6.3: The textile life cycle

6.4.2 Environmental objects and their constitution

The amount and hazardousness of wastes in the textile sector is shaped by:

- the use and emission of chemicals along the product chains from agriculture and chemical industry to the use phase, including laundry, and the post-consumer textile handling,
- the amount of textiles in use shaped by the ongoing renewal of fashion and specialisation and differentiation of products, and
- the globalisation of the textile sector, including the substantial outsourcing from Western Europe to countries with a lower level of governmental environmental regulation of the industry.

The textile sector has been part of the primary concerns of cleaner technology programs and local environmental regulation schemes in Denmark (Søndergård et al., 2001) and in other Western European countries. Several studies have analysed the dynamics of this development and interaction, which is summarised in the following. The prevention activities in the textile sector (cleaner technology, environmental management and product orientation) have had the following path:

1. Mid 1980s: environmental surveys
2. Beginning of 1990s: demonstration and technical development,
3. Mid 1990s: general projects and attempts to create a product-oriented approach
4. End 1990s and onwards: product orientation with focus on eco-label scheme and sector-based policy network

Synthetic fibres:

- Extraction of crude oil, natural gas

- Producing synthetic granulate

Fibre production:

- Extruding
- Cutting
- Baling

Yarns:

- Spinning

Fabric:

- Knitting
- Weaving

Fibre production:

- Ginning
- Baling

Natural fibres:

- Extraction of crude oil, natural gas
- Producing agricultural, fa

Some important actors in waste management and in innovation related to textiles are:

- Chemical industry (pesticides, chemicals for dyeing etc.)
- Fibre manufacturers
- Textile and clothing manufacturers
- Designers
- Clothing retail chains
- Supermarket chains with sale of textiles and clothes
- National and local authorities (innovation, competitiveness, environment)
- EU (innovation, competitiveness, environment)
- Branch organisations at different levels
- International organisations like WTO, FAO and UNEP

6.4.3 LCA studies on textiles

The life cycle assessments of textiles in chapter 4 and the qualitative description and assessment in table 6.6 show that the fibre production and manufacturing stages of textiles contribute significantly to the environmental impacts of textiles. The use stage may contribute to the biggest energy consumption if a textile is tumble dried. The biggest amount of product related waste is post-consumer textiles, which is either incinerated or land filled. Furthermore there is hazardous waste from the different steps of the production, especially due to the use of chemicals for fibre production and wet treatment in textile manufacturing. Waste water polluted with chemicals produce polluted sludge from wastewater treatment. In countries without wastewater treatment there is (of course) no polluted sludge from wastewater treatment, but instead polluted wastewater. Besides wastes from the production of textiles, there is a substantial amount of indirect waste from energy production from fossil fuels (ashes and dusts) for production, washing and drying. The energy-related waste contributes most to the generation of solid waste, ashes and radioactive wastes.

Table 6.6: Overview of processes, resources and waste types in the life cycles of textiles

Processes	Characteristics of processes, environmental impacts and resource consumption	Types of waste generated
Fibre production, natural fibres	Toxic impacts from application of pesticides in the growing and processing of natural fibres. Water consumption for cotton growing Energy consumption for production and application of pesticides and fertilisers	Packaging from pesticides and excess of pesticides (e.g. expired stocks) Organic waste polluted with pesticides from growing and handling of cotton and harvesting and handling of wool
Fibre production, synthetic fibres	Consumption of oil and natural gas in the production of synthetic fibres and of chemicals in the processing of natural fibres for synthetic fibres	Hazardous waste from use of chemicals
Spinning, knitting, weaving	Consumption of chemicals for increased speed of processes High level of polluted dust and of noise at workplaces	Dust polluted with chemicals from fibre production and from spinning etc. Polluted sludge from waste water treatment
Wet treatment	Consumption of water and chemicals for bleaching, dyeing, waterproofing, surface treatment for dirt repelling, fire retarding, printing etc.	Hazardous waste from handling of chemicals Polluted sludge from waste water treatment

	Wastewater pollution	
Cutting, sewing and packing	Manual and mechanised work Monotonuous work High level of dust at workplaces	Cuttings and trimmings, polluted with chemicals from previous parts of the production
Distribution and sale	Consumption of fuels for transportation with ships, air planes and/or lorries	Transportation packaging (cardboard boxes, plastic bags)
Use stage	Consumption of water, detergent and energy for washing and drying Waste water pollution from washing Chemical consumption for dry cleaning Energy consumption for ironing	Packaging (plastic, cardboard, paper) Waste water sludge polluted with detergents and excess chemicals from the clothes, including softener from PVC prints on clothes
Post-consumer handling	Second hand sales for reuse of textiles Recycling of fibres	Discarded clothes
Waste handling	Incineration Land filling	Small contribution to slag from incineration of metal bottoms etc. Waste from incineration of PVC

Source: based on Laursen et al (2006), Lewis & Gertsakis (2001) and Stranddorf et al (2002)

Waste minimisation can take place through consumption of fewer textiles, and through cleaner technology strategies aiming at reducing the amount and toxicity of wastes during the production of fibres and textiles. Due to the big environmental impact from the production stages of textiles waste prevention through extended life time, reduced consumption, and reuse of textiles and waste minimisation through recycling of textiles are potentially very important strategies from an environmental point of view. The big environmental impact from the production stages imply that cleaner technology during the production of textiles can reduce the environmental impact substantially, including the hazardousness of waste, for example through the use of organic cotton or substitution of chemicals for wet treatment processes (Laursen et al 2006). Since most of the wastes from the life cycle of textiles is related to energy consumption, reduction of this type of waste demands a reduced energy consumption, which can be obtained through energy savings during production, less transnational transportation of textiles and a reduction of tumble drying of textiles. Among the post-consumer product waste management strategies land filling and incineration have a significantly higher negative environmental impact than recycling.

The consumption of pesticides for cotton growing is very intense. Hille (1995) mentions that while 2.3% of the cultivated land was grown with cotton 18 % of the pesticide consumption was used on this land. Lewis & Gertsakis (2003) mention that around 10% of the world's pesticide consumption and 25% of the insecticides produced are used in cotton growing.

A Danish study of the washing out of chemicals from textile and clothing showed a big variety in the percentage of the wash out (from 0.1% to more than 100% (because some chemicals also are created during washing). 12 chemicals are assessed as causing problems in the aquatic environment (and thereby also in waste water sludge). 6 chemicals might have effects and 7 chemicals could not be assessed due to lack of information. 20 chemicals poses risks to some extent to consumers and employees in the retail sector (Laursen et al, 2002). These chemicals will potentially also end up in the waste streams from discarded textiles in the post-consumer phase.

The amount of textile waste in household waste seems to be around 2-3 % w/w (Eunomia Research & Consulting, 2006). Behrendt et al (2003) mentions an amount of clothing waste at the consumer stage in Germany of around 960,000 tonnes in 1995, equalising around 12 kg per inhabitant.

6.4.4 Policies influencing waste and innovation

In the following an overview of the type of regulation influencing waste and innovation in the textile sector is provided and the interaction between waste related policies and innovation analysed. The paragraph discusses the international regulation of chemicals including pesticides and textile chemicals, the EU IPPC Directive, the EU Eco-label and a private labelling scheme for textiles.

6.4.4.1 Policies regulating chemicals in fibre manufacturing

Since the amount and the hazardousness of the wastes throughout the textile sector are influenced by the use of chemicals throughout the life cycle, it is important to look at the regulation of chemicals used in the textile sector. New chemicals are increasingly being approved under the European system; for agricultural pesticides this process is conducted under the Authorisation Directive 91/414. Under the EU system the active ingredients in pesticides are assessed by a committee of Member States, and if they are shown to be acceptable they are entered on a list of substances known as 'Annex I listing'. Once an active ingredient has been listed, formulated products containing the active ingredient can be approved in Member State countries for specified uses.

The review of pesticides registrations by the European Union (EU) resulted in the withdrawal of 320 pesticides in July 2003 and more were withdrawn later at the end of 2003. At present, there are two parallel systems for the approval of pesticides in EU member states. Under the first system, the scientific evaluation of pesticides is carried out at the national level. However, this is gradually being replaced by a system in which a major part of the scientific evaluation is carried out by the European Commission. This transition was introduced first for 'plant protection products' (mainly agricultural pesticides), but it is now being extended to other pesticides (known collectively as biocides). Many compounds are being withdrawn because they are not supported by companies for commercial reasons. However, in addition, some were being removed because they failed to meet the stricter health and environmental standards set by the review. Although some new chemicals are being approved it seems clear that there will be a net loss of pesticides. The review is due to be completed by 2008.

Since the major part of the cotton used in European textiles, are harvested outside of Europe the international regulation of chemicals is important. The Rotterdam Convention on the Prior Informed Consent (PIC) Procedure for Certain Hazardous Chemicals and Pesticides in International Trade came into force in 2004 and had been implemented on a voluntary basis since September 1998 in the form of the interim PIC procedure. The Convention started with 27 chemicals (including 22 pesticides). PIC is a procedure that helps participating countries learn more about the characteristics of potentially hazardous chemicals that may be shipped to them, initiates a decision making process on the future import of these chemicals by the countries themselves and facilitates the dissemination of this decision to other countries. The aim is to promote a shared responsibility between exporting and importing countries in protecting human health and the environment from the harmful effects of certain hazardous chemicals being traded internationally. The PIC procedure is implemented jointly by FAO and UNEP through the FAO/UNEP Joint Programme for the Operation of PIC (Rotterdam Convention..., 2004) Rotterdam Convention Secretariat, 2006) (Sustainable Agri-Food Production and Consumption Forum, 2006). Potentially the Rotterdam Convention limits the hazardousness of the applied pesticides and thereby the hazardousness of the chemical packaging waste from agriculture and of dust and trimmings from the manufacturing of textiles and clothes.

Organic growing of organic cotton should also be seen as a waste prevention or cleaner production strategy, since it prevents the use and emission of pesticides. Today a certification of the farm is needed in order to secure customers that the practice actually is following the organic rules. This is expensive to the farmers in developing countries. There has earlier been and are currently a number of projects aiming at building certification capacity in countries in transition (like the Balkan countries and Ukraine) and developing countries (like Vietnam and India), so that advice and certification can be conducted by local organisations and companies. A number of the current projects are managed by Helvetas, a Swiss development aid organisation. Some projects aim at building certification capacity and some at organising value chains with co-operation between a country in transition or a developing country and a Western company. Since 1997 Helvetas has been committed to supporting environmental-friendly and socially acceptable cotton production. In 2002 the first farmers in the Helvetas project in Mali started to produce organic cotton. In Mali organic cotton certification was achieved in 2003 (Helvetas, 2006).

6.4.4.2 Policies regulating textile industry

Some activities in the textile industry are regulated via the EU IPPC Directive (IPPC Directive, Council Directive 96/61/EC). According to the IPPC Reference Document on BAT (BREF note) for the textile industry 'the main environmental concern in the textile industry is about the amount of water discharged and the chemical load it carries. Other important issues are energy consumption, air emissions, solid wastes and odours, which can be a significant nuisance in certain treatments' (IPPC, 2003). The document recommends technologies and proposes acceptable emission levels. Walters et al (2005) questions the level of environmental protection secured by the BREF note. For example, they find it strange that the BREF note recommends the use of a process for wool scouring, where trichloroethylene is used, in order to wash out pesticide residues of the lanolin from the wool, since the solvent is classified as carcinogen and the BREF note accounts for the fate of half the solvent used as 'un-captured loss'. Up to half of the lanolin can be removed from the wool and used in the cosmetics industry as a feedstock, when it has been cleaned from pesticides. In the UK work has been conducted into the potential for composting waste lanolin, which however, raises concerns about introducing pesticides (or organic solvents) to the environment (Walters et al, 2005). The example shows how the chemicals used in the textile product chain may restrict the use of waste fractions for other purposes.

Partly prior and partly parallel to the implementation of the IPPC Directive and the shaping of the BREF notes, cleaner technology programmes have been set up in several European countries. There is no overview of how many of these programmes that had or have focus on the textile industry, but at least in Denmark and the Netherlands there has been focus on the textile industry. The Netherlands and Denmark have also transferred experiences to the Central and Eastern European countries (Wenzel et al, 1999; BECO Group Project Profile, 2006). The Netherlands is also involved in financing cleaner technology programmes to the textile industry in Pakistan, one of the countries with export of fabrics and textiles to Europe (see for example (NEC Projects..., 2006)). Similar programmes have also been organised in India and Vietnam, other important Asian textile manufacturing countries. These programmes have the potential to limit the hazardousness of the chemicals used for textile manufacturing and thereby the hazardousness of post-consumer textile wastes in Europe. There is no joint overview of the impact of these programmes.

6.4.4.3 Product-related policies and actions

During the 1990ies, some European governments developed restrictions to the residues of chemicals in textiles and clothing due to the long-term skin contact, which means that this regulation is based on a health concern. Especially the German government's ban of azo-dyes has had big impact throughout the sector and was later the background for an EU ban of 22 azo-dyes that can release aromatic amines (some of which are carcinogenic) at concentrations higher than 30 ppm. Other chemicals, where the residues in the final product is regulated by a number of countries, are pentachlorophenol and its compounds, PCB and PCT (can be used as textile softener), harmful

heavy metals (including nickel) and formaldehyde (Policy Research Center for Environment and Economy, 1999). Ökotex 100 is a related privately organised product labelling scheme, which restricts the content of formaldehyde, heavy metals and other chemicals from the textile and clothing manufacturing and also on pesticides from fibre growing, harvesting etc. Some textile companies use the ability of suppliers to be approved according to Ökotex 100 as a kind of quality check for the capacity of the supplier (Stranddorf et al, 2002).

Similar to other industries different corporate strategies towards governmental regulation is developing: a front-runner strategy and a more reacting and adopting strategy. Front-runner companies translated for example themselves societal discourses on pesticides and on PVC into action. On the other hand, a retail chain practiced a more reactive and adopting strategy and substituted PVC because the Danish governmental demand for accounts for purchase and sale of products containing PVC became too time-consuming to make and later on they obtained eco-label on some of the clothes they sell, because they became a member of the sector product policy network (Forman et al, 2003).

Another type of product-related regulation is eco-labelling. The EU Eco-label is based on Regulation 880/92 from 1992 and revised in 2000 (Regulation 1980/2000). It is a market-based instrument that is meant to stimulate both the supply and the demand of products, which have reduced environmental impact in different parts of the life cycles of a product group. The European Union Eco-labelling Board (EUEB) develops environmental criteria for product groups in collaboration with the Commission. The actual development of a proposal for the criteria is done by an ad hoc working group with national representatives from EUEB and coordinated by one of the countries, often a country with an economic interest in the product area (Tanasescu, 2005). Denmark coordinated the development of the textile criteria, which from the beginning only focused on T-shirts, but later was developed to comprise almost all textile and clothing products. A company applies for a license to its national so-called Competent Body, which awards the label, after the approval has been announced in an official EU newsletter. The criteria document is revised every 5 years. Earlier this period was shorter, but in order to give the innovation activities in industry the best conditions the period of validity was extended. When a new set of criteria is approved, are also those aspects, which will be considered for inclusion in the next revision, announced in order to give industry better opportunities for making innovations, which may be eligible for a longer period.

The eco-label criteria for textiles and clothing contain demands to limits to toxic residues in the fibres and air water and pollution during fibre processes. Furthermore the criteria have limitations to the use of substances harmful for the environment in the production, use and end of life of the textiles. There are for example limitations to the level of impurities, the level of formaldehyde, heavy metals, PAH and COD in wet processes. Finally the criteria also have demands for the quality of product like colour fastness and shrinkage (EU Flower Criteria..., 2002). These type of criteria is relevant for a reduction of the toxicity of wastewater sludge from wet processes and from textile laundry and furthermore a reduction of the hazardousness of waste in terms of cuttings and trimmings and post-consumer products.

The EU-labelling scheme is not a success at EU level in relation to textiles, since a small country like Denmark has around 40% of the licenses (27 out of around 64 licenses in 2006) (Ecolabel Companies by Country and Product Group, 2006). Some of the barriers seem to be lack of knowledge about the eco-labelling scheme and the costs for obtaining and having a license (0.15% of the product's annual sale in the EU up to a maximum level). Some industrial players complain that they have to pay for being environmentally friendly. The counter-argument from for example the Danish Eco-label Secretariat is that the companies get free public relation and marketing of their products from the work carried out by the Secretariat. There is awareness about the indirect uses of the eco-label criteria (in general, not necessarily specifically for textile products). The criteria might

be used by other eco-labelling schemes, in public and private procurement calls for tenders, by companies as a benchmark for their own products, and to generate environmental product declarations (Tanasescu, 2005). A Global Eco-labelling Network (GEN) has been organised in order to allow for mutual recognition of eco-labelling scheme and thereby avoid that these schemes act as trade barriers. Many of the members are Asian countries, but also a few European ones, including Denmark.

Eco-labelling schemes have been a topic for discussion and disagreement in WTO. The background is that some countries claim that the criteria concern processes and production methods (PPM) in the manufacturing country, which is not eligible in WTO, unless the criteria also improve the impact on the consumer or the environment in the country where the product is sold. The EU has changed its eco-labelling scheme in order to make it more eligible in a WTO context by allowing companies outside EU to apply for a license. Besides demonstrating the limitations to the waste prevention policies it also demonstrates the limitations to IPP in cases where the pollution is process related and outside the reach of the regulator.

6.4.4.4 The shaping of eco-labelling in the Danish textile sector

The textile sector in Denmark is one of the most successful sectors in Europe when it comes to the implementation of the EU eco-label, the EU Flower. Therefore it is interesting as a special contribution to the understanding of creating policy regimes. Within the textile product area, around half of the licenses have been obtained by Danish companies. This success, at least in terms of number of labels, was based on the Danish strategy with so-called product panels as one of the measures within a product-oriented environmental policy. These panels were set up as experiments, which should bring the actors within industry, the retailers, the consumers and the regulators together, as a policy network strategy (Forman et al, 2003). The textile panel brought together more actors than those that have been active in the cleaner technology projects, since also the retail sector and NGOs members in the panel. The panel made an action plan, where the development of a collection of eco-labelled clothes and interior textiles was an important part of the plan. The idea was to show that it is possible to make eco-labelled clothes and also to bring them on the market in order to give the consumers the opportunity to choose more environmental friendly clothes and textile products. The plan can be seen as a way of addressing demand and supply at the same time. The textile product panel seemed to have had the role of a socially committing network, since a number of the companies represented in the panel, including more environmentally reactive companies, have obtained an eco-label as part of this campaign.

There are, however, several prerequisites for the campaign, which has shaped the eco-label as tool, and which should be seen as elements in this strategy:

- The shaping of some agreed eco-labelling criteria: the Danish EPA offered that Denmark could co-ordinate the EU working group that developed the proposal for the criteria, which then later on was approved in the EU
- The setting up of a Danish eco-label secretariat that gives advice to companies, which want to obtain the eco-label, and controls the collected documentation for the fulfilment of the criteria before the label is approved
- The development of a handbook on textile eco-labels with a description of how the criteria should be understood and a number of declaration forms, where suppliers just need to sign in order to guarantee that they are not using certain chemicals etc. The 'reality' behind these declaration forms is to some extent controlled by the eco-label secretariat.

The shaping of the eco-label as regulatory measure shows how the eco-label is developed as a boundary object, which is able to connect the business world and the environmental concerned. The labelling scheme is organised so that it on the one hand is easy for companies to obtain the label (the fact that the actual practice of certain supplier can be documented by a declaration signed by the supplier), and on the other hand the criteria are developed and approved in working groups and

committees, where also consumer organisations are represented. The criteria themselves are also balancing between environmental concern and the actual business practice. For example it is allowed to document the use of pesticides in the cotton growing and picking by analysing a sample of the cotton in stead of having to control the practice in the cotton fields. This practice is allowed because many different cotton growers are delivering to the same cotton processing plant. Furthermore companies often do not buy directly from a processing plant, but buy an amount of cotton at the Cotton Exchange, so they might even not know the processing plants. This practice of analysing a sample of the cotton is, however, no guarantee for the type and the amount of pesticides actually being used in the cotton fields (Stranddorf et al, 2002). The panel chose to use the EU Flower as the eco-label scheme of the campaign, because the criteria in this scheme are closer to the actual practice than criteria of the Nordic scheme, the Swan, because the Nordic scheme demands use of organic cotton, which was seen as too complicated. Furthermore, a European scheme was considered as giving export opportunities at a bigger market. The hope was also that more modest environmental criteria would attract more companies.

Another barrier to the eco-label originating from the business practice in the branch is the frequent shifts in fashion, including design and colour, which is an inherent part of the market strategy in big parts of the sector. The companies are advised by the eco-label secretariat to obtain the label for a certain type of fabric so that the same label can be used on different products and during a number of seasons and collections (in contrast to a license obtained on a specific product with a specific colour). However, no fashion clothes company has yet wanted to obtain the label. More recently, the focus has been directed towards the customers and the manufacturers at the market for professional work wear clothes. The volume of the single product is higher and the price competition maybe not so strong. (An initiative focused on a vision for the future of work wear at the European level was organised 2001-2002 by the EPE, the EU funded partnership alliance European Partners for the Environment, which include public authorities, companies, trade unions, NGOs and so-called social partners and professionals) (EPE, 2002)

The limits to the dyeing agents which are allowed within the eco-labelling schemes do hardly limit the possibilities of the textile companies to obtain the colour they want through interaction with the dyeing company (Stranddorf et al, 2002).

The satisfaction with the impact of the licenses on textile products on business performance was found to be modest in a Danish study of five textile companies with licenses (Kawansson and Roy, 2002). Some of companies are disappointed about the amount of products they have been able to sell. The practice around a technology as in this case the labelling scheme, is also shaped by the non-users. Among the non-users is an international retail chain, which also has shops in the US, where the EU label is not being recognised. These retailers have therefore made their own code-of-conduct, which contains a number of the same criteria as the EU Flower.

The case studies in (Forman et al, 2003) includes a professional product-service system, a textile-service system, which has been used as an arena for mediation of environmental demands for eco-labelled textiles (and detergents). This kind of product service systems has been organised for many years by companies organising the service of textile and cloth supply to hotels and industrial companies, where the textiles and cloth are owned by the service company, which distributes, collects, wash and redistribute the textiles and cloth. This may in itself be a product service system, which is more sustainable than each company buying and washing its own textiles and cloth, because industrial laundries are more resource efficient than semi-professional washing machines. Recently the pressure from some of the professional customers, including a hotel chain, has introduced a number of environmental improvements into at least one of these product service systems. The improvements include eco-labelled textiles and cloth and less polluting laundry based on less polluting detergents. The planning has involved co-operation among a number of the actors in this product chain, including the textile and cloth supplier, the laundry machinery supplier, the

detergent supplier, the textile and cloth servicing company, and the initiating hotel chain (Jørgensen, 2003).

6.4.4.5 Extended product life time and utilisation of textile products

The ever-changing fashion of textile and clothing combined with the relative reduction of prices on textiles and clothing sold in some parts of the retail sector has implied an increase in the amount of clothing items many citizens have, as mentioned earlier. Røpke (2000) mentions besides ever-changing fashion also the product diversification as a driver behind the increased sale/purchase of products. The citizens are not just having a big amount of the same type of shoes, but for example different shoes for different purposes and occasions.

This increasing purchase and stock of products imply, together with the outsourcing of the industry, a bigger waste amount with a higher hazardousness of the waste. The increased hazardousness is due to the relatively lower level of environmental protection, which characterises most industries in developing and newly industrialised countries. The toxicity of the chemicals is addressed by the eco-labelling criteria, but the increasing amount of clothing items is not addressed by governmental regulation. Four types of private initiatives should be mentioned:

- extension of product life through the design of the product
- extension of material life time by closed material loops organised by a product service carpet manufacturing company
- extension of product life time through second-hand shops
- increased use of a reduced number of products through schemes for sharing or renting of textiles and clothes.

A carpet manufacturing company has organised itself as a product service company, which owns the carpets files, while the customers buy the service of having a floor covered with carpet. The business model reduces the amount of waste and has in a combination with several initiatives focusing on use of natural fibres and substitution of hazardous chemicals implied a reduction of the amount and of the hazardousness of the waste (Lewis & Gertsakis, 2001).

In the European Union, consumers discard every year 5.8 million tons of textiles. Around 2001 only about 1.5 million tons (25%) of these post consumer textiles were recycled by charity and industrial enterprises. About 1 million tons was exported directly to Third World countries and about 0.5 million tons was converted to various products and sold inside the European Union. The remaining 4.3 million tons (75%) of these post consumer textiles are land filled or burnt in municipal waste incinerators, representing an unused source of raw materials. Of the 0.5 million tons that is recycled, the main applications are wiping rags, fibre production and application in the paper industry (Innovative technologies for ... 2001).

A study of recycling of clothes via charity organisations shows that the energy, which is used for collection and washing/cleaning of the clothes, only is 1-2% of the energy used for the manufacturing of the clothes (Woolridge et al, 2006). This means that these activities not only reduce the amount of waste and thereby the material consumption, but also reduce the energy consumption.

The German textile company Hess Natur has taken two initiatives to reduce the resource consumption by reducing the necessary number of clothes, which the consumer needs. They have designed a so-called 'long life collection' of classical clothing that is said to be unlikely to go out of style and which can be combined with other items over a much longer time-span than normally. Furthermore they have established a lending service for wedding outfits, because they otherwise very often would be used once (Paulitsch, 2001). An analysis of the practice and future visions for so-called eco-services based on renting, leasing, sharing and pooling, reports within the area of

textiles and clothes only about renting of tents and about nappy laundry services (Behrendt et al, 2003).

6.4.5 Policy impacts - patterns and regimes

This section summarises the waste related aspects of textiles, including the interaction between waste minimisation policies and practice and innovation.

The summary focuses on three aspects in relation to the above mentioned: the influence of globalisation on the importance of cleaner production strategies, the interaction between eco-labelling and innovation and the consumption-related waste, and initiatives aiming at reducing the consumption of textiles.

6.4.5.1 Cleaner technology and globalisation

Cleaner technology programmes in a number of European countries have focused on the textile industry as has been the case in the Netherlands and Denmark. There have been achievements in terms of more optimal use of a number of chemicals and substitution of some chemicals, among these some dye chemicals. An example of waste prevention policy, which has initiated innovation, is the Danish regulation of PVC. In the textile sector the focus on substitution of PVC, where possible, have initiated substitution away from PVC in textiles and led to innovation of PVC-free products and also a shift in retail strategy away from PVC- products towards existing non-PVC products.

The globalisation of many textile product chains is a challenge to the European waste prevention policies as they have been practiced in a number of European countries, to some extent parallel to the outsourcing of production. There is a big difference in the environmental practice among textile companies. Low price is often a dominating concern in the outsourcing of manufacturing and in the sourcing of products. Only a limited part of the Western industry and the retailers raise environmental demands to suppliers. Some companies raise environmental demands to their suppliers, while others more are focused on purchasing cheap products. Some fashion companies may practice a certain level of environmental management although they do not want to use this as an issue on the market, but see it as preventive damage control in relation to their brands, which they see as the core business concern.

It is not the technological level of the suppliers, which seems to be the problem, but the limited environmental concern of Western industry and retailers. Danish case studies show that when Western industry and retailers do set demands to the suppliers it is possible to get these demands fulfilled, either through co-operation (symmetric or asymmetric partnership) with the existing supplier or by searching for other suppliers – for example by following in the wake of other customers, which raise the same demands. There is some transfer of experience with cleaner technology in textile industry from European countries to developing countries and especially to countries in transition in Central and Eastern Europe. It is not clear, however, how much such programmes have led to actual changes and investments and how much the projects primarily have identified options for technology transfer.

The formalised system of certification and inspection poses some challenges to the more limited capacity in many developing countries and countries in transition. In some countries the cotton growing is by tradition organic, but is not organised with documentation of practice. The transfer through public funded projects and programmes of experience from Western countries to developing countries and countries in transition of technological and regulatory capacity within certification capacity for organic cotton growing is a way of securing that Western waste prevention policy can be transferred to these countries.

6.4.5.2 Eco-labelling and innovation

Only a small percentage of the companies seem to use eco-labelling criteria as a tool in the dialogue with suppliers in global product chains. Maybe an increased public focus on the need for upstream product chain responsibility of the Western companies sourcing for products could increase the use of the eco-label criteria as a supply chain management tool, where a part of the translation of the environmental concern is 'given' to the companies. Furthermore, these criteria will often also improve the occupational health and safety conditions in the supplying companies.

Eco-labelling as waste prevention strategy faces some challenge from innovation in the textile sector and has only obtained very limited success. The Danish experience indicates some of the challenges:

- The complex, global structure of the product chains in the sector pose challenges to eco-labelling, where focus is on documentation and maybe co-operation with the companies upstream in the product chain. The shaping of the EU eco-label criteria for testing of pesticide residues in cotton to fit to the present global structure is an example of the shaping of prevention policy to fit innovation conditions.
- Companies need support to find out how they can combine a certification and labelling strategy with the frequent changes in design. The Danish eco-label secretariat's suggestion for a flexible use of the eco-labelling licenses, so that companies can use a license for a range of products and seasons is another example of a shaping of prevention policies so that they fit to the present structural and economic conditions.
- The limits to the dyes that can be used within the EU eco-labelling scheme pose only limited restrictions to innovation in terms of the colours which are possible to obtain.
- Some companies claim that an eco-label is difficult to combine with the promotion of their own brand and they fear competition between the type types of branding.

6.4.5.3 The consumption-related waste

The amount of waste from textiles and clothes are probably increasing as the annual purchase of clothes (and footwear) is increasing. No policy initiatives are addressing this issue of increasing resource consumption and waste. One of the drivers behind the increased consumption is the relative cheaper textile products at some parts of the textile and clothes market, which are based on the outsourcing to low-wage countries of a lot of the manufacturing of the textiles and clothes and a strong price competition at some parts of the market. At the same time the outsourcing implies that the level of environmental protection is reduced in a relative big share of the manufacturing capacity producing for the European market, because the level of environmental protection often is lower in developing and new-industrialised countries. This combination of higher consumption of textiles and clothes implies that more waste and more hazardous waste is generated. Furthermore there are problems with chemical residues in clothes produced with a low level of environmental protection, due to excess use of the chemical and use of more hazardous chemicals. These residues increase the chemical 'pressure' on/exposure of the consumer and also the content of hazardous chemicals in solid waste and wastewater sludge. Problems with such chemicals in waste water or solid waste creates also problems in the recycling sector. However, there is not many available data for the content in the sludge and the solid waste. In this context the implementation of REACH may play an important part as the un-wanted residues of chemicals etc. should be taken seriously in the products for use.

Due to the ongoing changes in fashion, many clothes are probably thrown away or going into post-consumer handling long before they can be said to be worn out. The clothes more become 'morally' too old. There are only few examples of reduction of the consumption of textiles and clothes through extension of life time of products through more 'lifelong' design and through organisation of product-service systems. These cases could be seen as a kind of innovative response to the need for waste prevention. The case study shows that only a limited amount of the textile waste is recycled (25%).

6.4.6 Effectiveness of policies and future challenges

Cleaner production programmes during the 1990's in a number of Western European countries have focused on the national textile industry and obtained improvements in relation to chemical use and emissions to waste water and have thereby obtained a reduction in the amount and hazardousness of waste from Western textile manufacturing. However, the impact of these programmes has been limited by the, almost parallel, substantial outsourcing of textile manufacturing to especially Eastern European and South East Asian countries. The global structure of the cotton production, the diverse structure of cotton growers and the substantial purchase of cotton via a cotton exchange have limited the possibilities for prevention of chemical wastes at the source. Some European countries have established environmental capacity development programmes in some of the countries, where textile manufacturing has been outsourced. However, the impact of these programmes seems to be limited. The weak environmental regulation in many Eastern European and South East Asian countries imply that mainly companies that receive environmental demands from their European (or American) customers focus on reduction of environmental impact. However, a substantial part of the European textile industry and retail sector is not focusing on environmental impact related to the production and consumption of their products, but mostly on reducing costs and increasing the number of changes in fashion. The efforts in promoting eco-labelling schemes could potentially influence the upstream manufacturing in other countries. However, the eco-labelling strategy has only demonstrated little quantitative impact on the textile manufacturing and consumption patterns although the industry, in some countries, have been advised how they can obtain eco-label licenses, which are not limiting the possibilities for innovation and fashion changes. If the industries apply for licenses that cover a type of material and processes and not a specific product fashion changes may not demand a new application.

The low cost strategy and the strategy of product differentiation and changing fashion have implied an increased consumption of textiles among Western consumers and thereby implied an increase in the amount of post-consumer solid waste **and** in the environmental impact along the product chains of textile production. A waste prevention policy should emphasise the role of the importers and producers of textiles and encourage them to use their capacity in demanding and supporting improvements in the textile product chain. This is even more important when the competition in the textile sector is pushing for lower prices and even more short lived, fashion based consumption, which leads to pressure for lower qualities with shorter product life time, and probably less environmental consciousness in the upstream product chain. As the knowledge and technologies for environmentally improved textile production is available the market forces and the hidden wastes and pollutions seem to be the most pressing problem for consumption policies in this area.

There is a need for the future REACH scheme to address this upstream use of chemicals and the impacts from manufacturing in developing countries and from the use and laundry phase in the European countries. The emissions or discharges during the use phase should not be seen as unintended (or incidental) discharges, which – according to the present outline of REACH - could allow the textile importing companies not to care about the chemicals being used upstream. However, such a translation of the REACH scheme in the ongoing RIPs (REACH Implementation Projects) would limit the role of REACH in the regulation of the big amount of chemicals in the textile sector to nearly nothing. Given the fact that there are substantial releases of some chemicals during especially the laundry part of the use stage, such a translation used for the implementation and shaping of the future REACH scheme will fail to address this issue.

A future challenge to the textile waste management comes from the increased innovation of so-called technical textiles utilising new materials and chemicals in treating textiles for specific properties of use or fashion, including electronic textiles, where electronic components are integrated into the single piece of textile or clothes. This implies that a part of the future textile

waste need to be handled as potential hazardous or electronics waste. If these products also are manufactured in countries with a low level of environmental protection – which at least might be the case for chemically treated textiles for water and smell resistance – the content of chemicals, heavy metals, and the types of plastic used might also imply problems in the household laundry and in the post-consumer waste handling.

6.5 Building and construction materials, waste prevention and minimisation

Many different types of materials are used in building and construction projects before they end up as waste in the demolition sector or in the waste management sector. The largest fractions of building and construction waste are concrete, bricks, tiles, wood, and asphalt. Large volumes of waste are generated in the building and construction sector in Western Europe. The sector accounts for about 32% of all waste generated in Western Europe, but it only accounts for 2% of all waste generated in Central and Eastern Europe (EEA, 2003). The large difference can be attributed to poor waste statistics or to different definitions of waste, but it can also be interpreted as an indicator of the large amounts of building and construction waste that will arise in Central and Eastern Europe in the future because of the anticipated economic development. The lessons learned from waste prevention policies in the building and construction sector in Western Europe and the knowledge about the impacts the policies have had on innovation and on the environment are therefore also relevant for the countries in Central and Eastern European.

6.5.1 Material flows of building and construction materials

In Figure 6.4 the building and construction material life cycle is illustrated. The life cycle initially starts with the extraction of sand, stone, gravel, and other raw materials. After manufacture and use of building materials the building and construction waste can be recycled or re-used as substitutes for the manufacturing of building components based on other inputs because of the possibilities of open and closed material loops in the demolition sector.

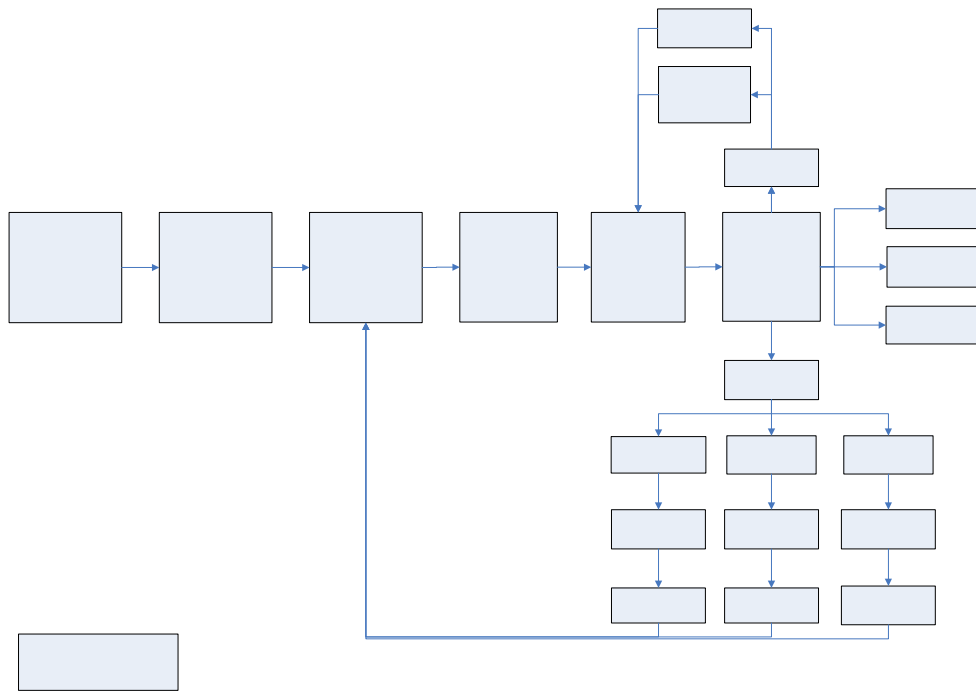

Figure 6.4: The building and construction material life cycle

Building and construction materials include numerous types of materials like concrete, wood and glass, but they also include products that are known to be harmful to the environment or human health like isolation, asbestos and PVC-products like window frames and drain pipes. The service life cycle of building and construction materials is generally long compared to other product life cycles and often the largest environmental impacts will not appear before the materials end up as waste in the demolition sector or in the waste management sector after some years or in some cases even after decades.

Some general trends in the building and construction sector are that the building stock is increasing while the life span of the buildings is decreasing. Modern materials as e.g. gypsum and fibre boards have expected life times of down to 20 years. At the same time elements of the private home as bathroom and kitchen appear to be linked to changing fashions that succeed each other at increasing pace thus stimulating this disposal of existing and still functioning building elements.

Extraction of
sand, stone and
gravel, crude oil,
metals and wood

Crushing,
Screening,
Refining,
Melting
Cutting

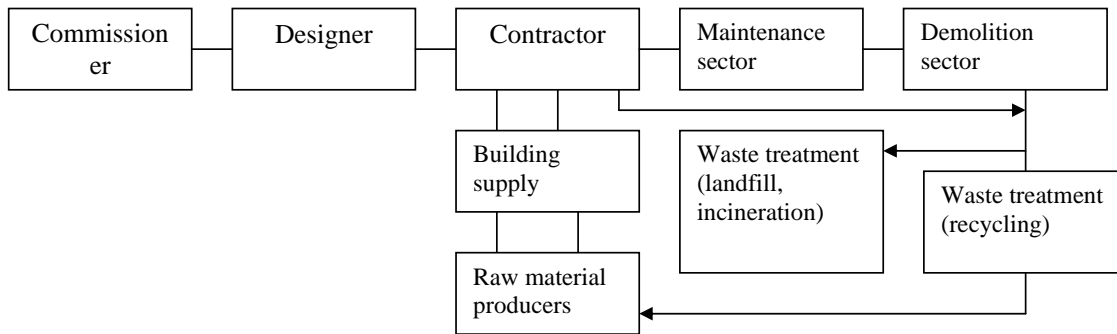

Source: Kemp et al. (2004) (based on Verheul and Tukker (1999))

Figure 6.5: The building chain

In Figure 6.5 the relationships of some of the main actors in the building chain are illustrated. The chain starts with the linkage of the commissioner of a building or construction project with the designer of the project. The designer is also engaged with the contractor who again is engaged with the building industry suppliers. Up-stream the building supply industry is engaged with the raw material producers.

In the figure it is illustrated that the contractor can also influence the choice of waste treatment options of building and construction waste in the demolition sector. An example of this linkage could be an agreement between regulators and the contractors' association on selective demolition of building materials.

In the demolition sector building and construction waste is sorted for recycling or reuse as is the case for e.g. clay bricks, masonry, and pavement (Sara et al, 2000), and alternatively for land filling or incineration. When building and construction waste is reused or recycled the building chain changes its character into a building cycle, where the recycled materials become potential substitutes for the extraction of new raw materials.

It is noteworthy that the building sector also imports waste from other sectors. Primarily inert waste is reclassified as filling material for large projects such as the construction of roads, dams, and harbours. But also particular polluting fractions are integrated into building materials: Sulphuric acid from flue-gas cleaning is integrated in gypsum boards. Heavy metals and sulphur fractions are integrated in asphalt tars, and fly ash in cement.

Figure 6.5 is of course a simplified illustration of the building chain/cycle, but it can serve as a useful point of departure for an analysis of the most important material flows and relationships in the building and construction sector. The figure is also useful for an analysis of the impacts of policy instruments for waste minimisation (recycling) or prevention (reuse) or innovation in different parts of the service life cycle of building and construction materials, as it will be illustrated later in Figure 6.6.

But, and maybe for reasons of simplicity, there are some omissions from the figure in comparison with contemporary waste treatment technologies. It is for example not included in the figure how slag from waste incineration and residues from coal-fired power plants (slag, fly ash, gypsum, and flue-gas cleaning products) can be used in building and construction projects.

Using residues from waste incineration plants and coal-fired power plants is an important example of the impact of waste prevention in different stages of the service life cycle of building and construction materials because of the large volume of waste. It is not possible within the scope of this study to investigate the environmental impacts of these activities, but the options for reuse/recycling are considered to be limited because of the fact that the residues are contaminated with a number of heavy metals.

6.5.2 Environmental impacts and their constitution

When building and construction waste is disposed of at landfills, one of the main concerns is the contamination of water, especially ground water. The environmental impacts from the incineration of building and construction waste are related to the incineration of e.g. PVC products from building and construction projects.

As already mentioned, hazardous substances can contaminate building and construction waste that is reused or recycled. Recently attention has therefore been directed towards removing different substances from building and construction waste. One existing technology is to wash out the harmful substances of the recycled materials to obtain an environmentally responsible recycling.

Removing harmful substances from building and construction waste is an example of waste prevention in the same way as the reuse of building and construction components. In a recent study for the Danish EPA on hazardous substances in building and construction waste twelve harmful substances were identified and investigated (DEPA 2006).⁹ It was recommended, that efforts be made to provide information and education in relation to the handling of harmful substances in building waste within the construction sector. It was particularly recommended that the national demolition association be prescribed to implement effective methods for the identification, removal and handling of these harmful substances.

6.5.3 LCAs on building materials

In this report the case study of building materials encompass building materials including minerals, insulation, and glass since these are a high volume part of the waste stream and relevant for its potential for reuse. An overview of the life cycle can be seen in figure 6.5. Due to the vast amounts of waste in this sector the contribution to environmental impacts are considerable as shown in chapter 4.7.

A more extensive literature study has recently been performed by Wenzel et al. (2006). Wenzel et al (2006) identified 24 LCA studies related to aggregates including construction and demolition waste and different end of life options for this waste streams. An evaluation of the studies was performed following the main criteria that the study should include a comparison of two or more options for management of waste aggregates, it should be a holistic environmental study, preferably a quantitative LCA, meeting a set of methodological quality criteria, and results of the study should be unambiguously ascribable to aggregates. This selection resulted in two studies that were included in the analysis.

Both studies compare recycling against land filling. Incineration was not included as an option in any of the 24 studies probably due to the fact that aggregates are in general not combustible. The two studies reviewed comprised two or more scenarios leading to a total of 6 scenarios compared.

⁹ Lead; cadmium; mercury; nickel; chromium; copper; zinc; polychlorinated biphenyls (PCB); chlorinated paraffins; chlorofluorocarbons (CFC); hydrochlorofluorocarbons (HCFC) & hydrofluorocarbons (HFC), and sulphur hexafluoride.

All 6 scenarios indicate that there is a saving of greenhouse gas emission by recycling, which ranges typically between 1 and 10 kg CO₂-equivalents/kg aggregates compared to land filling. Even though the remaining 22 studies were not directly included it should be mentioned that they all favour recycling as well.

Also when looking at other impact categories (Other energy related impacts, toxicity and waste) there is a clear preference for recycling as the most environmentally preferable with typical values of at least 10-20% and up to 70-80% reduction in environmental impact. Only the category 'Other, road transport' is less beneficial for recycling with half the scenarios resulting in higher impacts from recycling. However, this seems to be less important since greenhouse gas emissions are significantly less for all the recycling option.

Due to the facts that aggregates represent a major share in waste streams and that they can be considered relatively energy-intensive in production and transport, recycling seems to have a large potential to reduce related environmental impact by substituting primary aggregate material.

Based on the experience from all of the 24 studies evaluated, Wenzel et al. (2006) suggests the following issues may be subject to further investigation regarding aggregates:

- Generation of more, quantitative studies comparing waste disposal options
- Identification of realistic potentials for recycled aggregates to substitute primary materials, e.g. construction materials, covering environmental, technical and economical aspects
- Clarification of co-product issues, e.g. slag from incineration or from sand casting processes, used to substitute an equivalent quantity of primary material (e.g. sand or gravel)
- Determination of significance and feasibility of separation technologies for onsite and off-site recycling of complex products
- Determination of overall existing data basis of LCA data for aggregates and related processes

In conclusion, waste prevention in the building sector is considered to be most environmental beneficial if directed at areas where land filling is the preferred option.

6.5.4 Policies influencing innovation, environment and waste

Depending on the design of waste policies the purpose of the policy can be to influence the technological development in the waste management sector or to reduce the environmental impacts of goods and services through product or process development. Innovations of waste treatment technologies are generally regulation-driven, and can be classified as examples of 'end-of-pipe innovation'. The technological developments of products are often customer-driven, but while the purpose of product innovation seldom is to reduce the environmental impact of a product in its entire life cycle, the functionality of the products are at in focus.

The end user has often little or no influence on neither the specific design of the built construction nor the choice of materials used. Specific materials may be seen as a result of deliberate design in some instances, but more general so-called cultural factors also have a large influence in this. These factors include regional traditions of building as well as the different preferred methods of craftsmen.

The long life span of buildings often implies sequentially multiple owners to buildings and other constructions. Also the general concerns of the owners may change over time: Older houses are for example constructed with few and easily separated fractions and with a long life span, while the energy and comfort standards of recent years may lead to the conclusion that they perform poorly because of lack of insulation and thermal glazing.

In Figure 6.6 different regulation options in the building chain/cycle are illustrated using the demands of raw material producers, construction demands in the building supply industry, and waste regulation, as examples.

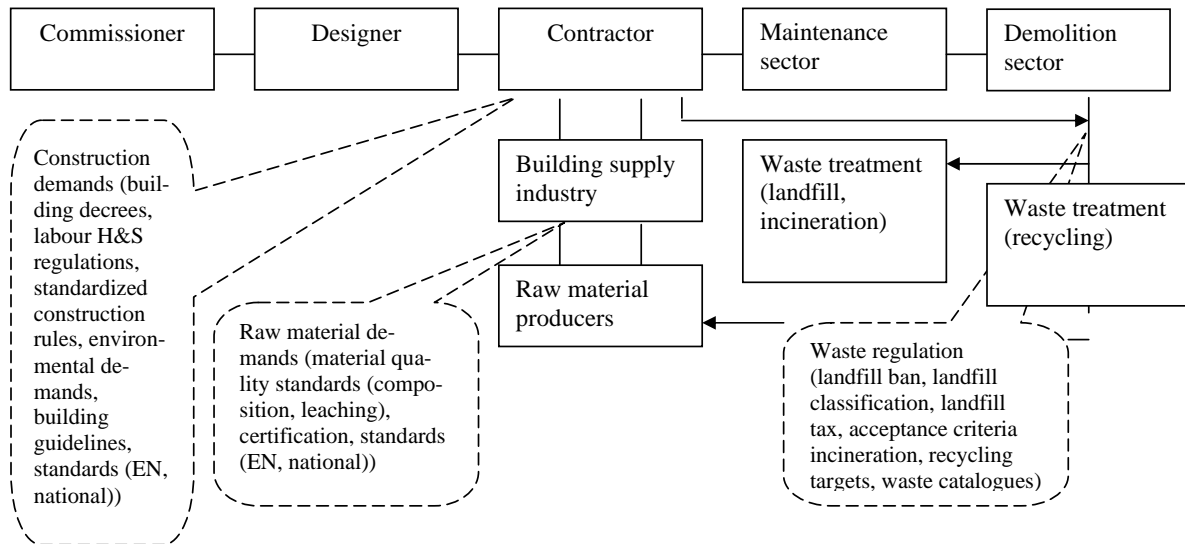

Source: Kemp et al. (2004)

Figure 6.6: The building chain and the regulatory framework that governs it

Changes in the raw material demands and the construction demands can have an impact on the materials used in new building and construction projects. The impacts of waste prevention policies on innovation in architecture, engineering and construction will mainly appear after some years or decades because of the long service life cycle of building and construction materials. The dominant trend of ‘intelligent houses’ implies increasingly complex constructions, where a growing number of different elements such as electronic systems and ventilation are integrated into the building.

Innovations in the construction sector have been dominated by the construction material and component producers. To overcome this imbalance other stakeholders in the product chain comprising of construction and engineering companies as well as housing companies buying new buildings have created networks focussing on creating innovations in the building construction sector, which could be regarded an example of so-called ‘organisational innovation’.

Also building codes play a part in the construction sector and have in several countries in northern Europe resulted in e.g. radical reductions in the energy consumed for heating and ventilation. Building codes can also play an important role in setting standards for the quality and assembly of building materials and components and by ensuring that this kind of ‘level playing field’ (indirectly?) affect the demolition waste and the potentials for re-use of materials.

Opposite to making future building and construction waste cleaner, changes in the regulation of waste treatment can have an immediate impact. In a recent study of three examples of innovations and the effects of regulations on their development one of the conclusions is that ‘technological innovations do not play an important role in the optimisation of construction and demolition waste recycling’ (Verheul and Tukker, 2000: 69). This is also the general impression from reading three recently published books on innovation in construction (Manseau and Seaden (eds.) (2001), Jones and Saad (2003), and Miozzo and Dewick (2004).

Increased pressure on the speed of on site construction work leads to an increased use of glues, foams, and other complex chemical based substances for assembly. This contributes to the pollution of main fractions of building materials and can potentially lead to more complicated processes when de-assembling buildings. The same problems can arise from the use of lighter building materials with a shorter lifespan in e.g. internal walls and parts in buildings.

The same tendencies are resulting from the balance between material prices and wages favouring building new and substituting old parts instead of repairing. This is e.g. the case for doors and windows where rather long lived wooding parts are often substituted with aluminium or PVC parts with a much shorter lifespan and with less potential for repair and maintenance.

Waste prevention and minimization have been the overall targets for a strategy on waste management of the European Community for many years. Reuse of bricks, masonry and pavement and the removal of PVC-products from building and construction waste would be examples of waste prevention in the building and construction sector.

The building and construction sector can also contribute to waste prevention by:

- Supplying quality buildings with long lifetimes and using environmentally-friendly materials,
- Ensuring optimum material utilisation by avoiding wastage or damage to materials,
- Demanding high quality materials and products with waste prevention in mind and delivered in returnable packaging, and
- Employing environmentally correct design or equivalent tools/methods (Danish Government, 2004).
- Removing harmful substances from building and construction waste

These contributions could be studied in detail together with the development in recycling rates of building and construction materials/waste in different countries.

There are differences in how demolition waste is handled. For example Hungary has established regulations in 2004 for the management of construction and demolition waste. Here a large majority of construction and demolition waste is regarded as inert and can be land filled with less strict obligations. This has made it relatively cheap to landfill demolition waste, which is also indicated in the very high rate of land filling (HUMUSZ, 2005).

However, the common ordinance from 2003 on the technical requirements of building products practically banned the use of alternative building materials (Népszabadság 2004). According to the ordinance, only certified products, specifically produced for building purpose can be used for construction purposes. Such certification can be obtained on the prerequisite of type examination, sampling and analysis in the manufacturing factory or the construction site and supervised manufacturing. This has in practical terms resulted in a ban of all building materials, which are not produced in an industrial process (e.g. wooden shingle, reed, adobe bricks, lime, and straw).

6.5.5 Policy impacts - patterns and regimes at play

Regulation is often considered to be a driver for innovation in the area of e.g. environmental technology (McGlade 2005). But describing and analysing the linkages of environmental policy and innovation in general, and waste prevention policies and innovation in specific, is difficult and complex for different reasons.

In some countries large volume of building and construction waste is prevented from being land filled or incinerated. One of the most important and visible impacts of the waste policies in these countries is a very high recycling rates of building and construction waste. The policy impacts seem to be the result of a life cycle approach to regulation that is based on a combination of tools, e.g.:

- An agreement with the national demolition association on selective demolition of building materials,
- Public funding for R&D in cleaner products and technology in the waste treatment sector,
- The use of economic instruments (e.g. landfill/waste tax) in the waste treatment sector, and
- A ban on land filling of some combustible waste fractions

In an evaluation of the impacts of the Danish waste tax from 1987 to 1996 it was summarised that the tax had played a decisive role for the recycling of building and construction waste, and that a new industry had emerged because of the tax (Skou Andersen et al 1998; 120). The impact of different policies on this kind of organisational innovation is of course difficult to quantify.

The important role of national and international public regulators and the national demolition association in encouraging the recycling or reuse of building and construction waste is illustrated in the extended building chain/cycle in Figure 6.7.

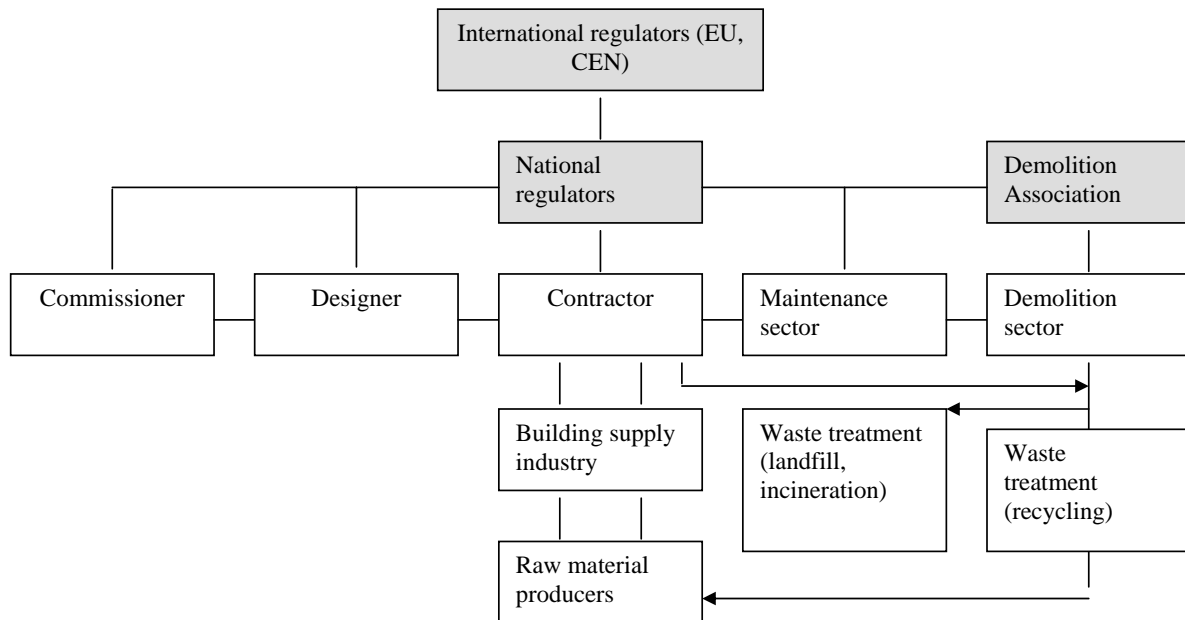

Source: Based on Kemp et al. (2004)

Figure 6.7: The building chain and the extended regulatory framework that governs it

Compared with Figure 6.6 another omission is the importance of regulators and the different levels of regulation. The international level of regulation has become more important for the countries in the European Community. In the latest Danish waste strategy, it is recommended that any waste prevention strategy that builds upon product-oriented initiatives should be implemented at the European level (EU or the European Standardisation Committee (CEN)) (The Danish Government, 2004: 112). The recommendation illustrates the importance of a life cycle approach to waste policies rather than approaching the waste problems within national boundaries.

6.5.6 Effectiveness of policies and future demands

Due to the relatively long product life cycles in the building and construction sector, it seems wise to have a dual focus in the policy of building and construction waste, where one focus is on

improving the technological development of existing technologies in the short term, and another focus is on developing and using new environmental friendlier materials and assembly processes for building and construction in the long term.

For building materials or at least materials with the highest volumes, i.e. minerals, insulation and glass, the environmental assessment again shows that reuse or recycling is by far the environmentally preferable solution to end of life deposit by e.g. land filling. Most parts of building materials will not be incinerated and therefore waste prevention should be directed at areas where land filling of building materials is the preferred option.

To minimise the amounts of building waste an economic approach to internalise the environmental externalities from building and construction could be to introduce the concept of life cycle costing (LCC) in the planning of new building and construction projects. While several projects in e.g. cleaner technology programs have had this focus, still major improvements can be made in the building construction sector with its diverse and often poorly coordinated actors.

Two groups of important public actors for waste prevention in the future – the architects and engineers in one end and the managers in the demolition and the waste treatment sectors at the other end - belong to very different stages of the service life cycle of building and construction materials. Different policy measures are therefore necessary to have an impact on the architects and engineers, who are responsible for designing the buildings in the future, and on the managers, who are responsible for the choice of waste treatment in the demolition sector. Researches and others within the field of ‘sustainable design/architecture’ who try to balance economic, environmental, ethical and social issues in product design and development are probably driven by other factors in their research and development than waste managers.

The large amounts of building waste has made charges an often used tool to make reuse and recycling a more feasible and attractive alternative for waste handling companies. These economic instruments have showed to be very effective and have – even within few months – changed waste streams away from depositing to alternative uses. While the use of charges is efficient in controlling the amount of waste the content of eventual hazardous and polluting fractions of building wastes is difficult to control, and therefore the success must be followed up by establishing improved procedures for controlling the waste and the conditions for reuse especially in the parts of Europe where even the statistics on building waste are almost absent.

The role of waste separation procedures in demolishing buildings is demonstrated in the case about PVC, where the use of PVCs in the building constructions counts for the majority of PVC used. In the future more complex materials will show as composites and in technologies used for assembly of components and parts making the disassembly processes and the control of building wastes for reuse more demanding. Therefore the focus on building design and the choice of materials for building construction are vital for a waste prevention policy in this area.

6.6 Packaging and packaging waste, waste prevention and minimisation

Numerous types of packaging are being used by producers and consumers before the different materials eventually end up as packaging waste in the waste management sector. The largest fractions of packaging waste are metal, plastic, glass, cardboard, and wood. In these case studies of packaging glass bottles and aluminium beverage cans are used to illustrate the impacts of waste policies on waste prevention (re-use of glass bottles) and waste minimisation (recycling of aluminium beverage cans) supplemented with some considerations also about packaging waste policies having a broader scope.

6.6.1 Material flows in the production, use and treatment of packaging materials

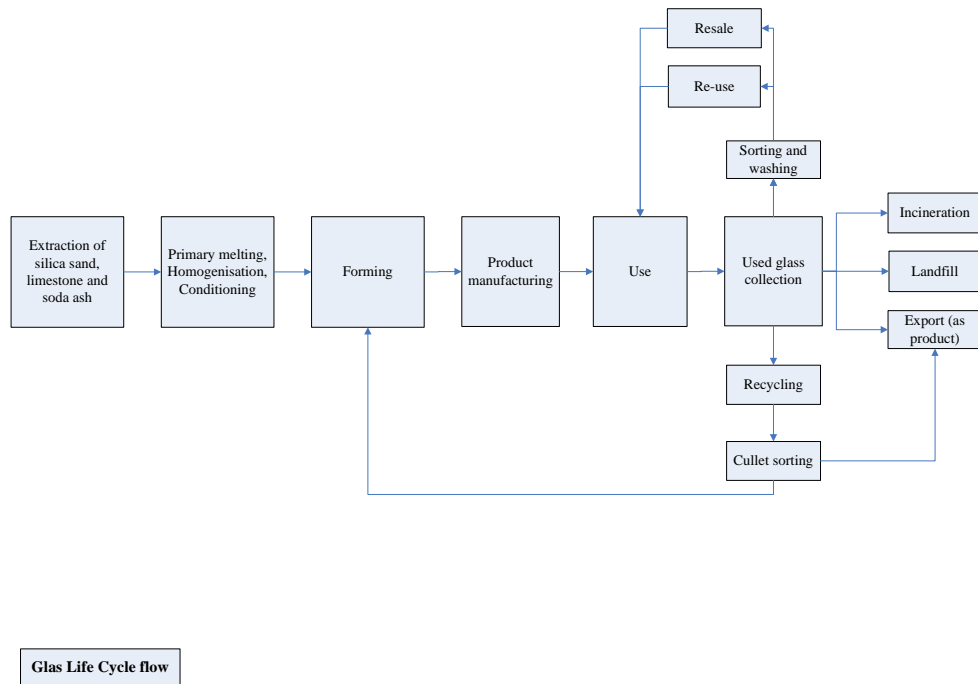

Figure 6.8: The glass material life cycle

In Figure 6.8 the glass material life cycle is illustrated. The life cycle initially starts with the extraction of silica sand, limestone and soda ash for primary glass manufacturing, but because of the possibilities of open and closed material loops of used glass the collected glass can be re-used or recycled and thereby substitute for the manufacturing of primary glass. An example of this is the life cycle of glass bottles. The unbroken glass bottles can be collected and re-used after cleansing, while the broken glass bottles are re-melted after collection.

6.6.2 LCAs on packaging materials

Packaging materials are probably some of the best investigated through life cycle assessments (LCAs). The results from a recent review are summarised here. The reviews were performed by Wenzel et al. (2006).

A summary of the results of primary packaging materials is given in table 6.7. The values indicate the number of scenarios with preference for each option.

Table 6.7: Summary of the assessment of overall environmental preference of waste management options across all reviewed scenarios (After Wenzel et al., 2006).

The values indicate the number of scenarios with preference for each option.

Scenario		Paper	Glass	Plastics	Aluminium	Steel
Recycling vs. incineration	Recycling	22	8	32	10	8
	Incineration	6	0	8	1	1
	No preference	9	1	2	0	0
Recycling vs. landfill	Recycling	12	14	15	7	11
	Landfill	0	2	0	0	0
	No preference	1	0	0	0	0

It is clear from the results in the table that recycling of packaging materials generally is environmentally preferable to other waste management option besides, of course, waste prevention, which was not included in the original study.

More details about the three dominating materials in packaging (paper and cardboards, glass, and plastics) as well as aluminium will be presented in the following.

6.6.2.1 Plastics

From a basis of 42 plastics related LCAs 10 were selected in Wenzel et al (2006) as high quality following the main criteria that the study should include a comparison of two or more options for management of waste plastics, it should be a holistic environmental study, preferably a quantitative LCA, meeting a set of methodological quality criteria, and results of the study should be unambiguously ascribable to plastics.

The 10 studies all contained two or more scenarios leading to a total of 60 scenarios comparing incineration, land filling and recycling. In many of the studies, the ready-making of the collected material before recovery, typically cleaning/washing, is an essential part of the system, and in all cases where this is relevant, it is considered and included. The review demonstrates that this can be of key importance.

Three different groups of scenarios were distinguished:

1. Scenarios that anticipate recovered material to substitute virgin material of the same kind in the weight/weight ratio of 1:1.
2. Scenarios that anticipate recovered material to substitute virgin material of the same kind in the weight/weight ratio of 1:0.5.
3. Scenarios including substantial washing/cleaning of the plastic product before material recovery is possible, in which this washing/cleaning has the dominating environmental significance.

Recycling vs. landfill was only investigated for group 1 where there was up to 100% saving in greenhouse gas emissions.

The picture was a bit more varied when comparing recycling vs. incineration. For the group 1 scenarios there was a clear benefit of recycling with the majority of scenarios showing savings of 25-50% greenhouse gas emissions. The average saving was 1.5 to 2 kg CO₂-equivalents pr kg plastic. For the group 2 scenarios 5 out of 8 scenarios showed recycling to be beneficial where as 3 showed that incineration is the most beneficial. Reductions/increase in greenhouse gas emissions were 0-25%. For the group 3 all 5 scenarios showed an increase of up to 100% in greenhouse gas emissions by recycling in stead of incineration. From these results it is obvious that the recycling procedure and how the recycled plastic is used is of very high importance.

6.6.2.2 Paper and cardboard

A large base of 108 studies was identified on paper and cardboard. Using the same criteria as mentioned above 9 high quality studies were selected for the final review. Each study comprises one or more scenarios of varying system boundary conditions and assumptions, and a total of 63 scenarios comparing the three main waste management options to each other are included in the review

The review finds that *recycling* is by practically all existing studies found to be environmentally preferable to *land filling* and to the prevailing *mix of incineration and land filling* in the studies and countries covered by the studies, which is around 20-30% incineration and 70-80% land filling. The comparison between *recycling* and *incineration* is more varied. Within some impact categories recycling is by the majority of studies found to lead to reduced impacts. This is the case for:

- overall energy consumption,
- energy related impacts of acidification, nutrient enrichment and photochemical ozone formation,
- toxicity, and
- other impacts (COD in wastewater effluents and land use).

Within other impact categories (consumption of fossil fuels, global warming, and solid waste) the results of the reviewed studies show more evenly distributed advantages and disadvantages for recycling and incineration.

The results on overall energy consumption follow a very evenly distributed normal distribution with an average of 50% less energy consumption when recycling instead of incinerating paper and cardboard. In other words, the aggregation of results from the reviewed studies shows that: *on average virgin production followed by incineration with energy recovery consumes twice as much energy as recycling*. The reason that this result does not reproduce itself for the energy related impacts is that the energy systems behind virgin paper/cardboard production and paper/cardboard recovery are different: whereas the energy underlying virgin production is to some extent based on CO₂-neutral fuels, the paper/cardboard recovery operations are typically solely based on fossil fuels.

One issue that turned out to be important for the conclusion was whether or not the study would look at the raw material wood as an unlimited resource or as a possible resource in the energy sector. If wood is used for paper it would deprive society of the possibility of using it in the energy sector and would imply an equivalent use of fossil fuels in the energy sector to compensate.

Also three other issues were important: The energy source for production of paper, the marginal electricity assumed and whether the extra incineration capacity produced by recycling would decrease land filling. The system boundaries and assumptions are very important for the results.

6.6.2.3 Glass

For glass more than 200 relevant studies were identified in Wenzel et al (2006). Using the same criteria as mentioned above 11 high quality studies were selected for the final review. Each study comprises one or more scenarios of varying system boundary conditions and assumptions, and a total of 25 scenarios comparing the three main waste management options to each other were included in the review.

The assumptions that have highest influence on the results are those related to the interdependency of the glass waste handling system on the energy system of the surrounding techno-sphere, including:

- The type of energy used for manufacture of primary glass;
- The type of energy used for manufacture of secondary glass from recycled cullet;

-
- The type of recycling process applied (closed loop recycling seems to be superior to recycling in open loop processes, e.g. in aggregates).

The overall conclusion from the 11 studies reviewed is that closed loop recycling of glass has a lower environmental impact than the alternatives of incineration or land filling. There are, nevertheless, a few scenarios deviating from the general picture. These are either rather extreme scenarios presupposing e.g. poor recycling rates and long transport distances or open loop recycling scenarios, where the recycling of glass requires more energy than the extraction of the virgin raw material, which is substituted.

In average the saving attained through closed loop recycling ranges from 0.58 to 0.60 kg CO₂-equivalents/kg glass compared to land filling/incineration. The situation was more ambiguous for open loop recycling due to some of the scenarios examined. The average saving in CO₂-equivalents in the scenarios considering open loop recycling is in the order of 0.06 kg CO₂-equivalents/kg glass compared to land filling.

To summarise, the review showed that the type of recycling applied can be an important issue when determining the relative advantage of recycling compared to either land filling or incineration. Hence, closed loop recycling seemed superior to both incineration and land filling in environmental terms, while some types of open loop recycling, e.g. in aggregates or filtration media, seemed to be disadvantageous. Consequently, generation of information on the life cycle wide environmental implications of alternative open loop glass recycling options would be relevant as a subject for further investigation. In the review, the scenarios dealing with open loop recycling options originated from one single study and examined life cycle CO₂ emissions only.

6.6.2.4 Aluminium

For aluminium 11 studies were chosen for in depth analysis, comprising 20 scenarios.

In summary, 17 of the 20 scenarios concluded that recycling was the preferred waste management option whereas 3 concluded that incineration was preferable. In none of the studies was land filling the preferred option.

6.6.3 Policies influencing innovation, environment and waste

The actors in the different stages in waste generation are affected by different factors. According to Linher (2003) some factors are influencing the design and production stages. Other factors are influencing the production and use stages. And finally some factors are influencing the choice of best option in the reuse/recycling or disposal stages. This is outlined in figure 6.9.

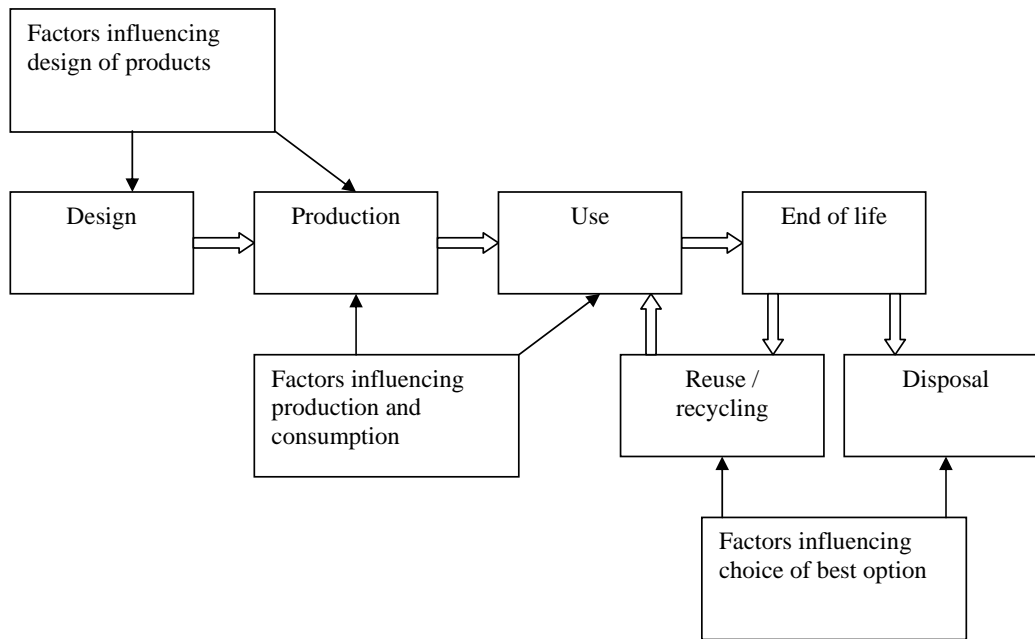

Source: Otto Linher (European Commission) in Monkhouse and Farmer (2003: 31)
Figure 6.9: Factors influencing the actors in the different stages in waste generation

In this section the framework outlined by Linher is used to analyse the influence of different factors on packaging materials and waste. The different factors are likely to have an influence on the environmental impacts of packaging materials or packaging waste. One way of carrying the framework outlined by Linher further could be to analyse whether the main drivers for the factors in the different stages could be different. One of the factors influencing the design of a product could be *customer/market-driven* innovation that focuses on the functionality of a product in competition with other products or packaging materials. The factor influencing the production and consumption of packaging could be *technology-driven* and depending on the existing production technologies. Finally, one of the factors influencing the choice of the best waste treatment option could be *regulation-driven* by the implementation of national, regional or international waste policies.

6.6.3.1 Reuse and recycling of glass

In the following section glass recycling in Western Europe will be analyzed, using the most recently published recycling rates for glass bottles in 2004 from the association of European manufacturers of glass packaging containers and machine-made glass tableware (Fédération Européenne du Verre d'Emballage - FEVE) as an indicator of policy *outcomes*.

The links between waste policies and policy outcomes are analysed by dividing the countries from the FEVE statistics into two groups in Table 6.8: countries with high recycling rates of glass bottles (> 58%) and countries with medium or low recycling rates (<44%). The overall recycling rate for glass bottles in Western Europe in 2004 was 63% in 2004.

Finally, the information about recycling rates in different countries is combined with information about the use of deposit-refund schemes for glass bottles from the OECD/EEA database on instruments used for environmental policy and natural resources management (OECD, 2006).

Table 6.8: Glass recycling and deposit-refund schemes for glass bottles

Countries with high recycling rates	Recycling rate in 2004 (%)	Deposit-refund scheme for glass bottles
Sweden	96	Yes
Switzerland	96	Yes
Germany	91	Yes
Belgium	90	Yes
Norway	90	Yes
Austria	88	Yes
Netherlands	76	Yes
Denmark	75	Yes
Finland	72	Yes
Ireland	69	No information available
Italy	61	No
France	58	No information available

Countries with medium or low recycling rates	Recycling rate in 2004 (%)	Deposit-refund scheme for glass bottles
United Kingdom	44	No information available
Spain	41	No information available
Portugal	39	No information available
Greece	24	No information available
Turkey	24	Yes with reference to Table 3.19 in OECD (2006)

Source: The European Container Glass Federation (FEVE) (2006) and OECD (2006)

From Table 6.8 it can be seen that there is a close link between the implementation of deposit-refund schemes for glass bottles and the level of recycling rate. Almost all countries with high recycling rates have informed the OECD/EEA that they have implemented a deposit-refund scheme, while none of the countries with low recycling rates (except Turkey) have informed the OECD/EEA that they have implemented a similar scheme. It therefore seems reasonable to interpret the use of the text 'No information available' in the OECD/EEA database as an indication of that there is no deposit-refund scheme in these countries.

The recycling of glass bottles is clearly an example of a development that is driven by regulation. At the policy level, the change from the use of glass (and plastic) bottles to aluminium beverage cans (to be covered in the next section) is a step down from waste prevention to waste minimization. As already mentioned the recycling rates are indicators of policy outcomes (the effects of the policy on target groups/human behaviour) and not of the impacts on the environment and human health.

6.6.3.2 Recycling of aluminium beverage cans

In 2005 more than 25 billion aluminium beverage cans were sold in Europe (European Aluminium Association (EAA), 2006). In this section the use of deposit-refund schemes for aluminium beverage cans is studied in detail. A deposit-refund system is a surcharge on the price of potentially polluting products that is refunded when pollution is avoided by returning the products or their residuals.¹⁰

¹⁰ <http://stats.oecd.org/glossary/detail.asp?ID=594>

The most recently published data on the recycling rates of aluminium beverage cans in 2005 from the European Aluminium Association (EAA) have been selected as an indicator of policy *outcomes*, i.e. the effects of the policy on target groups/human behaviour (EEA, 2001: 20-26).

The links between waste policies and policy outcomes are analysed by dividing the countries from the EAA statistics into two groups in Table 6.9: countries with high recycling rates of aluminium beverage cans (> 70%) and countries with medium or low recycling rates (<53%). The overall recycling rate for aluminium beverage cans in Western Europe in 2005 was 52%.

The information about recycling rates in different countries is combined with information about the use of deposit-refund schemes for aluminium cans from the OECD/EEA database on instruments used for environmental policy and natural resources management (OECD, 2006).¹¹

Table 6.9: Aluminium beverage cans recycling and deposit-refund schemes

Countries with high recycling rates	Recycling rate in 2005 (%)	Deposit-refund scheme for aluminium cans
Norway	93	Yes
Finland	88	Yes
Switzerland ¹²	88	Yes
Sweden	86	Yes
Denmark	84	Yes
Benelux ¹³	80	Yes
Germany	73	Yes
Turkey	70	Yes

Countries with medium or low recycling rates	Recycling rate in 2005 (%)	Deposit-refund scheme for aluminium cans
Spain	53	No information available
Austria	50	n.i.a.
Poland	50	No
Italy	48	No
United Kingdom	41	n.i.a.
Ireland	39	n.i.a.
France	38	n.i.a.
Greece	36	n.i.a.
Portugal	35	n.i.a.
Hungary	33	No

Source: European Aluminium Association (2006) and OECD (2006)

From Table 6.9 it can be seen that there is a close link between the implementation of deposit-refund schemes for aluminium beverage cans and the level of recycling rate. All countries with high recycling rates have implemented a deposit-refund scheme, while none of the countries with low recycling rates have informed the OECD/EEA that they have implemented a similar scheme. It seems reasonable to interpret the use of the text 'No information available' in the OECD/EEA database as an indication of that there is no deposit-refund scheme in these countries.

¹¹ <http://www2.oecd.org/ecoinst/queries/> (last updated in April 2006)

¹² National/various containers; operated by private sector (Stavins, 2001: 53).

¹³ Belgium, Netherlands and Luxembourg.

Even in the countries with the lowest recycling rates more than one out of three aluminium beverage cans are recycled. This shows that some separation of the aluminium cans from other waste fractions actually takes place in these countries without the economic incentives from the refund in a deposit-refund scheme.

6.6.3.3 General policies on packaging waste

Another well-known example of the effect of waste prevention policy deserves to be mentioned here. As a response to the German Packaging Ordinance from 1991 the 'Green Dot' trademark and the 'Duales System Deutschland' were developed. By paying what is called a licence fee to the 'Green Dot' system a company will be released from all duties arising from the Packaging Ordinance. Following the first introduction it has been adapted to the amended legislation in Germany and the EU. The 'Green Dot' system is now operating in several European countries under the umbrella of the Packaging Recovery Organisation Europe. This policy has been an archetype for the new type of take-back policies that incorporate the extended producer responsibility as also seen in the WEEE and car take-back schemes. It has following the German example been introduced in quite many countries involving industries and government in setting up the schemes. As in Germany they typically involve an organisation to handle the collection and monitoring of the system. These systems have reached quite high recycling rates of packaging waste to above 75% in Germany, 70 % in Belgium and 60% in Austria and Sweden (Tojo, Lindhquist & Dalhammar 2006).

In Germany experience from the period where the 'Green Dot' system has been in place show that it has spurred innovations in reductions of the packaging materials and supporting its reuse. Especially the use of composites and plastics in packaging has gone down. Also changes in the design of packaging and the shape and size of containers have occurred (OECD 1998).

In Hungary the Environmental Product Charge Law has been introduced in order to stimulate the increase of recycling rates and waste prevention. Packaging waste is among the important waste streams regulated by the Law and recently WEEE has been also regulated similarly. The Law requires the payment of an environmental product charge on packaging based on its material and mass. This has been changed recently to be based on pieces, e.g. in case of plastic shopping bags. The emitter is required to pay, however it can receive an exemption from the payment if it can achieve a certain percentage of recycling (based on the Packaging Directive). The collection and recycling can be done by the emitter or by 'coordinating organisations' that are authorized to carry out such activities.

The scheme has operated successfully as the required recycling rates have been achieved. However, HUMUSZ has pointed out that since the rates can be easily achieved from production waste and thus coordinating organisations are not interested to invest in collection systems for consumer waste. Another criticism towards the state is that while 46 billion HUF has been collected during 5 years, only 13% of this amount has been spent in the same period for municipal waste management infrastructural development and waste management projects at companies. The remaining amount has been used as revenue for the state budget.

In July 2006, the European Commission has sent an official request for information to the Hungarian government about the environmental product charge as the first step of the infringement procedure. The procedure is started as a result of complains from the Beverage Can Makers Europe (BCME). According to the claim the charge is a tax discriminating certain economic actors, certain packaging types and certain packaging materials (and as a result the prices of aluminium-canned, cheap, import beers has increased significantly, consequently some products have disappeared from the Hungarian market). While the political goal behind the environmental product charge was exactly to internalise some of the externalities in case of cheap, but high environmental impact

packaging, the Commission seems to back BCME's initiative. It is also notable that this is the first case in the history of the EU that an infringement procedure has been started against an eco-tax.

According to a governmental decree from 2000 on the service fees covering waste management and disposal costs, municipalities are obliged to set a public service fee for the management of municipal solid waste. This fee can only in exceptional cases be a general lump sum, the fee has to be proportional to the generated waste according to the Decree. The Decree points out literally that the fee should be set so that it stimulates the decrease of generated waste. Thus the MSW management fee is an economic instrument directly stimulating consumer waste prevention.

Despite the well formulated decree many municipalities are not applying the principle of proportional payment. Many even do not introduce a waste management fee, but finances the costs from an ear-marked municipal tax or on the burden of other tax revenues. While this practice is against the principle of stimulating waste prevention, municipal leaders argue that in case of proportional waste management fees an increase in illegal waste dumping can be observed instead of waste prevention. This argument can be supported by the existence of around 10,000 illegal waste dumps in Hungary.

6.6.4 Policy impacts - patterns and regimes at play

Waste minimization and prevention have been the overall targets for the strategy on waste management of the European Community for many years. As mentioned in some of the former chapters, waste minimization policies and waste prevention policies can have mutual environmental impacts and impacts on innovation (concerning all parts including product, technology, organization, and marketing) that are difficult to distinguish.

The relatively easily accessible recycling rates for aluminium beverage cans are a policy outcome indicator for *waste minimization* and not for *waste prevention*. A proposal for response indicators for waste prevention is being developed by the OECD Working Group on Waste Prevention and Recycling, but so far the proposal is only seen as a preliminary set of response indicators for waste prevention that is subject to further discussion and analysis of data availability and evaluation of future data needs (OECD, 2004b: 62).

Following the OECD definition of waste prevention a policy response indicator for waste prevention will have to be an indicator for strict avoidance (prevention), reduction at source, or producer reuse, but information about some of these actions (e.g. strict avoidance and reduction at source) are not easily accessible. In OECD (2004b: 62) packaging is included to illustrate waste prevention using refillable plastic and glass bottles as examples of product reuse.

6.6.5 Effectiveness of policies and future demands

Primary packaging materials used are paper (and cardboard), glass, plastic, steel and aluminium. For both steel and aluminium the environmental impacts of land filling and incineration does not differ substantially, whereas recycling is preferable both in terms of environmental impacts and resource consumption. For the other materials the conclusions are not so clear cut since they depend on assumptions made for the studies. However, land filling is consequently the least environmentally preferable. For plastic energy recovery from incineration may be beneficial in relation to recycling if recycling requires washing/cleaning of the plastic or if only around 50% replacement of virgin material is assumed. For paper and cardboard the LCA data show that recycling reduces overall energy consumption in the life cycle to about 50% but for other impact categories the difference between incineration and recycling is more evenly distributed. In the case of glass, the conclusion is clear for closed loop recycling which is clearly better than incineration or open loop recycling. However, the comparison between open loop recycling and incineration is

more ambiguous and will depend on recycling rates and transport distances. It can be added that the economic costs of waste prevention of packaging generally is low.

Based on the two analyses of reuse of glass bottle and recycling of aluminium beverage cans, it can be concluded that waste packaging policies that include deposit-refund schemes are effective for achieving waste minimisation (recycling of aluminium cans) or waste prevention (reuse of glass bottles). Their effectiveness is dependent on the specific institutional implementation made for the recycling systems and one of the threats to the system are the marketing based strategies for diverse packaging introducing large numbers of different types of beverage packaging and even taking smaller products out of the recycling processes. Other measures like e.g. awareness-raising campaigns are likely to be part of the explanations of high recycling rates in some countries too, but information about these 'soft' tools are not as easily accessible as the information about the deposit-refund schemes.

It has not been possible within the scope of this study to investigate in depth the impacts of waste minimisation and waste prevention on innovation in other specific areas of packaging (marketing innovation). But the few examples of general packaging policies based on distributors and producers responsibility and take-back of packaging materials have turned out to be quite effective in reducing the amount of waste and also improving procedures for recycling and reuse of packaging materials. Especially the German 'Duales system' from the early 1990ies have demonstrated remarkable results though at some costs according to critics of the system. One of the more general impacts of the focus on packaging waste besides the recycling of beverage containers has been a reduction in the use of expanded foams using e.g. ozone depleting gases and a reduction in use of PVC for packaging all in all making packaging materials easier to recycle or incinerate.

6.7 Policy impacts on environment and innovation

The patterns found in the above cases will be summarized and analyzed for dominant patterns and regimes followed by an assessment of how these patterns seem to perform both in relation to innovations and in relation to the impact on waste minimisation and prevention. The conclusions in this last section of chapter 6 are at the outset case-based but will at the end of the section and in chapter 7 be compared to conclude and point to more general lessons.

6.7.1 Policy impacts concerning electronics

The growing amounts of waste from electronics and electrical products are a growing concern in Europe. As is the hazardousness of these waste fractions and their large part of slag, composites, contaminated glass, and gunk plastics difficult to reuse and still containing a large amount of resources and energy used. The main waste problems along the life cycle of these products are:

- the amount of rare materials used and energy used in the production of electronics and electrical product often resulting in large amounts of production waste,
- the energy consumed during the use of these products increasingly recognized as a problem and itself leading to large amounts of waste as energy production itself is one of the major waste producing sectors, and
- though some reuse and especially recycling of metals is already in effect, the end of life wastes contain large amounts of slag, hazardous materials, and gunk fractions.

The EC policy on electronics comprise of two main directives: WEEE and RoHS, which in combination with the new directive on the design of energy consuming products form a coherent and complementary policy pattern that will influence the design and production of electric and electronic products far beyond the European countries themselves. The RoHS directive is using a rather conventional legal instrument banning the use of lead, mercury, cadmium, brominated flame retardants, and a few other substances in all electronics and electrical products including those

imported to the EU. This traditional legal instrument turns out quite effective, and crosscuts year of testing weaker policy measures including pressure on the industry to innovate new products and processes. While very effective, the RoHS directive does only focus on the first ranked hazardous substances, while a number of second ranked substances are not included. RoHS thus successfully reaps the environmental innovations promoted by earlier weaker policy measures, but does not in itself facilitate future innovative activities that target other compounds.

With the WEEE directive an extended producer responsibility principle is introduced in a sector, where this regime has not been used before. The directive builds on a quite new policy regime – at least in the EC context – which is supposed to complement the specific policies on banning hazardous substances. It creates a common framework for shifting the costs of waste handling from the public waste handling systems to become the responsibilities of producers and importers. As the design criteria for products are not specifically addressed in the WEEE process, the impact of the directive on the design of electronic and electrical products is yet unclear. The complex supply chains and the focus on the product fee as a way of covering waste handling costs shifts the regulatory focus away from the environmentally friendly design of new products and to the responsibility for paying for waste handling and the building of new, private waste handling institutions.

The impacts of transferring the responsibility of waste handling procedures to producers and private actors does emphasise the need for a rather well defined government control and monitoring system, as there are several options for reuse, exports of waste, and separation procedures that can reduce the transparency of electronics waste handling and need careful handling of the definitions of waste prevention. The already existing ‘grey zone’ exports of electronics of products for reuse containing also waste components demonstrates the need for a new and extended public control and enforcement of waste prevention policies in relation to the complex institutional setup involved in policies based on the producer responsibility regime. Also the correct use of the classifications especially in the distinction between reuse, recycling, and waste processing need more elaboration as to handle the tradable, but often heterogeneous product-waste streams.

The overall conclusion concerning policy efficiency is that:

- a relatively coherent set of policies has been developed demonstrating a relevant mix of goals, specific policies on hazardous substances and measures to handle the waste demonstrating a quite effective policy pattern,
- though the impact on product design and waste prevention concerning the growth in this waste stream can be questioned as the specific way that the new producer responsibility regime has been institutionalised focus more on shifting the costs of waste handling to the producers and importers than to waste prevention actions.

The impact of these policies on innovation can be summarised as follows:

- the banning of hazardous substances have lead to both innovations in processes and products and a rather high speed of diffusion and implementation of these new solutions, while
- the waste prevention measures as regards to the extended producer responsibility do not – at least in the shorter perspective – provide a separate and efficient motivation for innovation compared to eh demands for improvements in product quality coming from markets and users, though
- future implementation of e.g. energy labelling and standards very well can turn out having positive impacts on innovations.

The success of the shift to a model based on extended producer responsibility is highly dependant on whether a market will develop for the reused materials of which only recycling of the metal factions have value today, whereas the large fractions of slag from circuits and components, contaminated glass and gunk plastics that have little or no present use nor value.

The conclusion concerning the overall impact on the environmental loads from waste is:

- the selective focus on certain hazardous substance in the first rank will be phased out in new electronics products resulting in a lower load in the waste stream of these substances to be expected in the next 5-10 years, while
- no further improvement in the composition of wastes are to be expected from the waste prevention policy besides a growing problem with the trans-border trade of 'products' for reuse and growing demands on enforcement of environmental protection laws.

Emphasis must be directed towards the potentially growing problems arising from trans-border and global trade of used electronic products for reuse including waste fractions leading to new challenges for control and enforcement methods to be developed and financed.

6.7.2 Policy impacts concerning PVC

The waste problem from PVC stems from its high content of chlorine and the additives used to stabilise and plasticize. At the same time PVC is been popular due to its multiple uses. The environmental problems show:

- in the production phase – especially in some of processes used including mercury and in the general hazardousness of the use of free chlorine,
- in the use phase the primary problem related to PVC has been related to the continued transfer of plasticizers based on e.g. phthalates and the freeing of acids in case of fires, and
- in the waste phase especially incineration has lead to a demand to contain the acid but also other processes leading to toxins like dioxin.

The policies introduced in the handling of a plastic material like PVC have in contrast to the relative success of the electronics waste policies been much less effective. The question is whether the policies focused on regulating the use and disposal of PVC at all have met the anticipated goals and have been implemented in a productive way. The overall picture is that the heated controversy and the confrontation between industry interests and environmental concerns have resulted in neither well defined impacts nor effective policies. Even in areas where the use of PVC demonstrates marginal benefits for society, but where the health and costs of waste handling are significant, have the introduced policies and the developed product alternatives not been implemented in an effective way.

One important lesson to be learned is the rather substantial influence that industry can have on the policy processes, especially in cases where the problems and uses are complex. It is also obvious that the policy processes ending in a limbo state does counter the utilisation of even obvious and useful innovations, which points to the need for overall policy goals. Industry's primary concerns have on reuse or recycling as a solution to the waste problems. This has functioned as a dead-lock for other policy initiatives, as the recycling activities have not demonstrated efficient return rates nor well defined ways to reuse. As the lifespan of hard PVC is long and sorting the different generations of PVCs difficult the content of heavy metals and other additives constrain the reuse and recycling.

The overall effectiveness of the policies introduced has been heavily influenced by the controversies about PVC and its uses. This has resulted in:

- a lack of consistent objectives concerning the handling and use of PVCs,
- rather different strategies concerning the policies on additives,
- very different waste handling practices throughout Europe leading to different interests and targets, and consequently

-
- unclear support measures for creating material substitutes as well as policies opening for reuse even though the results have been limited due both to the hitherto used heavy metal based stabilisers and the difficulties in handling plastics in the waste stream.

Even though policies have been unclear the continued controversy has spurred innovations in quite different directions like:

- development of substitute materials to avoid the dangers of acids in relation to fires in e.g. electrical installations and building and the use of soft PVCs,
- lately also development of substitute plasticizers with much less damage to health, processes for waste handling, and not least
- processes for decomposition of PVCs which combined selecting plastics from the waste stream is a much more promising alternative than reuse.

Despite the controversies and open ended, but weak regulatory framework have fostered innovative activities, the lack of a consistent strategy has not lead to effective implementations of these innovations even in those cases where the outcomes in any case would have been improving environment and health. Innovative activities may be prioritised to prepare for eventual future regulation but the implementation of these innovations are dependent on market demands again being dependent on consistent policy objectives and the regulatory frameworks.

The conclusion on the overall environmental impacts in the life cycle of PVC is:

- The production of PVC contributes significantly to the environmental impacts in the life cycle. Therefore, in principle a direct reuse or recycling with as low destruction of the PVC as possible is beneficial. However, due to the durability of PVC and the previous use of hazardous substances as additives, a qualitative prevention focusing on feedstock recycling is a better alternative.
- Waste prevention actions should focus on land filling and incineration of PVC due to the long term emissions and amount of secondary waste generated. Attention again should be given to the possible recycling of hazardous substances into new products which will limit the practical reuse possibilities for quite some years into the future.

A more dedicated focus and banning of the problematic and polluting additives and a differentiation in the accepted uses of PVCs would have made policies more effective and would also have supported innovations in a more dedicated direction. In the case of processes for decomposition of PVCs these are not falling inside the waste prevention policy targets, but would at least be the most relevant and efficient waste handling strategy in the coming decades.

6.7.3 Policy impacts concerning textiles

The growing amounts of household textile waste have not been in focus in waste prevention or waste minimisation policies. The policy focus in Western Europe on the environmental impact of textiles in a life cycle perspective has especially been on:

- emissions of pesticides used during the growing and harvesting of cotton, addressed as a human and eco-toxicological problem,
- emissions of chemicals into waste water of hazardous chemicals from the wet processes during the manufacturing and finishing of textiles, addressed as waste water problem and a hazardous waste problem,
- emissions of detergents and excess of manufacturing chemicals during the laundry of textiles in the use phase, addressed a waste water problem, and
- energy consumed during laundry of textiles, addressed as a resource consumption problem.

The biggest amounts of waste generated in the life cycle of textiles are waste from energy production from fossil fuels related to the manufacturing and use (laundry and drying) of the textiles. If textiles are tumble dried this process contributes to the biggest environmental impact during the life cycle of the textile. There is a substantial amount of hazardous waste from chemical use during the wet processing of textile.

The largest environmental impact from the production and use of textiles is the growing amounts of household textile waste because of the upstream environmental impact a piece of textile is “carrying” as embedded environmental impact from fibre growing and manufacturing, textile manufacturing and transportation of the textiles. The focus on cleaner production in textile manufacturing is a focus on cleaner products, but the growing amounts textile waste have not been addressed as a consumption problem caused by increased changes in fashion. The waste prevention policy of the EC demonstrates limitations when it comes to the growth of wastes from production processes and other types of pollution resulting from the growth in consumption.

Cleaner production programmes during the 1990'es in a number of Western European countries have focused on the national textile industry and obtained improvements in relation to chemical use and emissions to waste water and have thereby obtained a reduction in the amount and hazardousness of waste from Western textile manufacturing. This policy regime has been based on subsidy programmes for environmental innovations but has been limited by the, almost parallel, substantial outsourcing of textile manufacturing to especially Eastern European and South East Asian countries. There has been some direct transfer of experience to these countries through technology transfer programmes, but this transfer is not taken place in a systematic way and is mostly not linked to the outsourcing of production.

Some efforts have been made in the context of the new IPP strategies, including eco-labelling of textile products, but the voluntary regimes dominant among these instruments has demonstrated a limited impact and consequently also limited efficiency. A substantial part of the EU eco-label licenses on textiles is hold by Danish companies due to a policy network based regulation with focus on cleaner products based on agreement between manufacturers, retailers and consumer organisations about the promotion of eco-labelled textiles. The lack of trans-national product chain based policies needs to be addressed to produce a waste prevention regime in relation to global consumer products. This includes that the REACH implementation must address the upstream use of chemicals and the impacts from manufacturing in developing countries and from the use and laundry phase in the European countries.

The overall conclusion concerning policy efficiency is that there have been rather successful cleaner production programmes in some Western European countries focusing especially on reduction of the hazardousness of waste water and sludge. The programmes success has been related to the:

- combination of command-and-control measures (restrictions to waste water toxicity) with policy network processes with consensus building of the cleaner production programmes, economic incentives for front-runners (subsidies for cleaner production innovation), and dissemination through trade organisations and consultants, also followed by
- support for environmental management systems and policy network, and
- regulation focusing on coordinated development of demand and supply of cleaner products based on labelling and information campaigns.

Product chains have in some cases worked as arena for international mediation of environmental demands from governments and for dissemination of cleaner production solutions developed with background in domestic governmental regulation. This shows the importance of international coordination of governmental regulation in order to ensure dissemination of experiences and avoiding 'free riders'. This is, however, only possible within the EU due to for example the Water Frame Directive.

The impact of waste minimisation and waste prevention policies on innovation have only been addressed briefly in the literature. It has shown that:

- the environmental impacts from dyeing chemicals used in some parts of the European textile production have been reduced almost without limiting the possibilities for choosing colours as part of textile innovation ,
- also e.g. the Danish demand for accounting for PVC-products has made companies develop textiles, where PVC is substituted by other types of plastic, and made retail companies stop the sale of PVC-containing textile products, and more in general that
- some improvements in product qualities have surfaced, including organic fibres in a few cases, where companies have used eco-label criteria as a reference in the mediation of environmental demands to suppliers.

But at the same time fashion companies seem to be hesitating using eco-labelling as part of their strategy because they fear it may interact with the marketing of their brand in a non-foreseeable way, although the limits to the use of dyeing agents hardly imply restrictions to the colours, which can be obtained. The limited number of eco-label licenses may for some companies be based on a wish of not making their business strategy depending on the development in eco-label criteria. The few innovative examples of design of products with extended life time and product-service systems involving textiles and the second-hand sales of post-consumer textiles seems not to have been directly linked to waste minimisation or waste prevention policy.

The conclusions concerning the overall impact on the environmental loads from waste are that:

- the amount of post-consumer textile waste is increasing and thereby the total environmental impact from textiles in a life cycle perspective, and that
- the policies in a number of Western European countries have addressed the waste water pollution from the wet processes and thereby the amount of hazardous sludge as waste resulting from these.

The outsourcing of textile production to Eastern European and South East Asian countries with a lower level of governmental regulation implies that only when the European manufacturing and retail companies themselves raise demands to their suppliers may the level of environmental protection be similar to the level in Western Europe. This implies that some of the achievements obtained by cleaner production in Western European textile industry may be lost through outsourcing of production

6.7.4 Policy impacts concerning building waste

The environmental problems resulting from building waste is primarily related to:

- the large amounts of waste from demolition and re-construction work, and
- the growing fractions of composite and potential hazardous materials used in modern construction technologies.

Reuse and recycling strategies have therefore been popular and also somehow effective in reducing the amounts of building waste.

The use of waste charges as a major regime in the attempt to reduce the large amounts of building wastes ending for deposit have turned out to be very effective policy instruments. Instead the reuse and recycling have been improved as more feasible and attractive alternatives for waste handling companies. These economic instruments have – even over few months – changed the waste streams away from depositing to alternative uses. While the regulatory regime turns out efficient, the content of eventual hazardous and polluting fractions of building wastes is difficult to control. Also the transport of building materials from demolitions sites now defined as products for reuse make the control of waste handling agents more difficult opening for trans-border activities in Europe

with no clearly defined responsibilities for control and enforcement of the waste prevention principles.

At the same time the overall policy patterns in the building construction sector have been diverse and even though effort have been made to improve environmentally friendly design of buildings only few results are shown and mostly in more experimental buildings where dedicated constructors have demanded e.g. ecologically improved buildings. Therefore emphasis must be given to the development of building materials, building technologies, and design competences among architects and engineers. This might in turn also lead to innovations in this sector improving the environmental friendliness of materials and assembly methods used as well as the energy efficiency and the possibility for maintenance of the buildings.

Due to the relatively long product life cycles in the building and construction sector, it seems wise to have a dual focus in the policy of building and construction waste, where one focus is on improving the technological development of existing technologies in the short term, and another focus is on developing and using new environmental friendlier materials and assembly processes for building and construction in the long term. A strategic policy is therefore necessary to improve the design of buildings in the future including those aspects related to the maintenance of the buildings and the waste treatment in the demolition sector. The role of waste separation procedures in demolishing buildings is demonstrated already in the case about PVC, but in the future more complex materials and assembly technologies will make the disassembly processes and the control of building wastes for reuse more demanding.

In the case of building construction waste the effectiveness of policies can be easily summarised as:

- economic charges to redirect building waste from depositing to reuse and recycling has turned out very efficient in resulting in efficient reduction in quantities, but are
- heavily dependent on the control of the content of building waste and the correct use of building waste including the removal of hazardous substances, which demands more enforcement than often anticipated.

The innovative impacts from waste prevention and minimisation policies in the case of building construction materials have been scarce. There is a need for more focus on innovation in this sector addressing the environmental impacts already in the design and construction phase of building including their impacts during use and maintenance.

In conclusion the overall most significant impacts in the life cycle are:

- the huge amount of building materials waste contributing to considerable environmental impacts,
- the (growing) amounts of hazardous substances may contaminate the building materials waste and attention should be directed at removing these when recycling as the most prevalent disposal method is land filling, from which there is concern about leaching of hazardous substances from the waste, while there is
- a potential for relatively large saving in e.g. CO₂-emission when recycling is preferred to land filling and since building materials are relatively energy-intensive in production and transport, recycling can reduce related environmental impact by substituting primary aggregate material.

Also in the case of building construction waste their might be growing problems coming from trans-border trade leading to renewed methods in control and enforcement methods if waste prevention shall be effective.

6.7.5 Policy impacts concerning packaging waste

Packaging waste has been a growing concern due to:

- the amount of materials and energy used, and
- also the environmental impacts from some of the packaging materials like e.g. PVCs based on the used additives.

In the area of packaging waste the introduction of deposit-refund schemes have been effective in achieving waste prevention and minimisation goals using the reuse and recycling of aluminium beverage cans and glass bottles as examples. Their effectiveness, though, is dependent on the specific institutional implementation made for the recycling systems and on limiting the different types of beverage packaging. Here the many different systems and even more important the many exceptions made are limiting the overall results from the reuse of packaging materials and the efficiency of recycling of materials.

Also the few examples of general packaging policies based on distributors and producers responsibility and take-back of packaging materials as e.g. the German 'Duales system' have turned out to be quite effective in reducing the amount of waste and also improving procedures for recycling and reuse of packaging materials. One of the more general impacts of the focus on packaging waste in policy strategies and information campaigns has been a reduction in the use of polluting types of packaging materials as e.g. the reduction in use of PVC for packaging. This has resulted in making packaging materials easier to recycle or incinerate.

Policies and actions in the packaging area have been effective in some terms as:

- deposit refund schemes increase the return and therefore the reuse and recycling, though this is to some extent hampered by the variety of beverage packaging and the number of exceptions introduced, and
- extended producer responsibility and take-back of packaging materials, which has reduced the amounts of waste and improved procedures for reuse and recycling.

Some innovative impacts from waste prevention policies have shown in the area of packaging materials as:

- more efficient sizes of packaging have come about, as well as
- substitution of e.g. PVCs and also other plastic materials with more environmentally friendly plastics, recyclable paper, and other less polluting materials.

In conclusion some general findings on the environmental impacts in the life cycle of packaging materials are:

- that packaging due to the amount of waste produced packaging waste contributes significantly to environmental impacts, and that
- reuse/recycling reduces environmental impacts considerably especially in case of open loop recycling of glass bottles (direct reuse after washing) but also in case of material recycling (aluminium).

6.7.6 General lessons on policy impacts

When summing up the results from the case studies to identify more general conclusions about the impacts of waste minimisation policies on innovations it turns out rather clearly that:

- waste prevention and waste minimisation policies as such do not prove to have had a limiting effect on innovations in the cases studied, which some times has been argued, and that

-
- policies in these areas have created incentives for and also set directions for innovations improving both product improvements concerning materials and production processes used and waste handling technologies, but
 - limitations have shown in the cases studied related to a lack of consistency in how policies have been defined, coordinated, and enforced.

On the other hand:

- waste minimisation policies are not per se encouraging innovations as they often impact products at a phase in their life cycle 'distant' from the responsible designers and producers, and more importantly
- policies explicitly addressing extended producer responsibility need to be designed in a way, which addresses the design and production to prevent waste generation and the related environmental impact, if they shall be efficient in creating incentives for waste preventing innovations.

These general conclusions are though based on the limited empirical material collected in the cases due to the lack of data from international, comparative evaluations of the impact of waste prevention and waste minimisation policies. But it must also be recognised that the studies needed do are not easily produced.

The rather diverse set of measures which can be identified as having influence on the outcomes and effectiveness of policies supports the initial considerations in this report about the importance of coherent policy patterns and the coordination of policies following overall goals communicated clearly compared to the single choice of policy instruments. Several of the introduced policy regimes can – if implemented in accordance with the experiences and basic characteristics of their way of involving actors and creating incentives – turn out as very effective instruments to support the waste prevention and waste minimisation strategies. These include the use of:

- extended producer responsibility when addressing and defining incentives adequately for the core actors in the product chains,
- rather traditional policy measures based on banning of substances or setting finite goals for their substitution, and
- economic charges defined at a specific level and followed by necessary specific definitions, measuring procedures, and control and enforcement structures.

These instruments in combination with overall goals to be communicated widely have demonstrated to contribute to changes in the handling of waste, when the specific conditions for the design and implementation of the products ending up as waste are respected as they all demand certain conditions to become effective as shown in the case studies.

Waste minimisation can basically have two different perspectives. One perspective is the prevention of product waste by prolonging the life time of the product. The other perspective is the prevention of waste during the production of a product, so that the product itself becomes 'cleaner' or the production of the product has less environmental impact.

Many initiatives are not widely disseminated, but only implemented in some countries and among some frontrunner companies, maybe involved in a project or programme. The impact of waste prevention policies is therefore not only dependent of the effectiveness of the measures used and their coordination but also on the dissemination of the policies throughout Europe. The widespread globalisation of many product chains seems also to prohibit widespread dissemination, since the governmental institutions in developing or newly industrialised countries often are too weak to secure dissemination and implementation based alone on government regulation and control. However, the possibilities for transfer of Western European experiences to Eastern European countries within the EU would be better if focus is on a long term effort in developing the necessary regulatory regimes in the Eastern European countries. This could be complemented by building new

institutions to handle the cross border trade of 'grey zone' products and waste fractions, establishing coordinated and strong eco-labelling secretariats, and training of staff in existing environmental protection agencies in preventive environmental strategies. Such training should also include the staff in industrial companies, design companies and retail companies in strategies for environmental management in product chains and integration of environmental concerns in product development.

Continued negotiation with and pressure on industry concerning the need for setting goals for eco-design and the need for waste prevention seems to be important for producing a positive impact of waste minimisation policies on innovation. This is almost lacking in the electronics waste regulation as implemented. Attempts to regulate the use of PVC has spurred several innovations both concerning the substitution by other plastic materials and improvements in additives and decomposition supported by the public awareness and NGO focus on the impacts of PVC. However, within textiles the pressure for downstream responsibility for upstream pollution is not felt so strong that e.g. eco-labelling is used by European textile manufacturers and. An increased public focus on the upstream environmental impact of the production could probably make the textile and similar sectors more aware and concerned.

Very few policy instruments and supported efforts are focusing on limiting the amount of product waste by prolonging the life time of the product through 'social innovations' and 'market innovations' including the development of new product-service systems with changing responsibilities based on altered systems of distribution, ownership, and maintenance, which could include upgradeable and repairable products. This strategy could work with many different types of products like products within all five cases EEE products, textiles, building and construction, PVC and packaging. For products based on global product chains this strategy is a challenge, unless the products are based on strong brands, like cars, where more closed product/service systems exist. Such user-producer relations may increase the knowledge of the producer about the actual use of the products and thereby support the development of more user-oriented innovation strategies, which may be more competitive in a global economy, at least for SMEs.

6.8 References

ACRR (2003) The management of WEEE - a guide for Local and Regional Authorities, Association of Cities and Regions for Recycling.

AEA & REC (2006) Implementation of Waste Electric and Electronic Equipment Directive in the EU. EC & IPTS, EUR 22231 EN. AEA Technology and The Regional Environmental Center for Central and Eastern Europe.

Arnika (2004) Arnika warned customers against PVC goods, press release, 21.12.2004, <http://english.arnika.org/pressreleases.shtml?x=214930>

Baitz M, Kreissig J, Byrne E, Makishi C, Kupfer T, Frees N, Bey N, Hansen MS, Hansen A, Bosch T, Borghi V, Watson J, and Miranda M (2004). Life cycle assessment of PVC and of principal competing materials. European Commission, 2004.

BAN & SVTC (2002) Exporting Harm - The High-Tech Trashing of Asia, The Basel Action Network (BAN) and the Silicon Valley Toxics Coalition (SVTC).

BECO Group Project Profile: Feasibility study on export of cleaner technologies for Czech textile industry (www.beco.nl) (Accessed 15 July 2006)

Behrendt, S., Jasch, C., Kortman, J., Hrauda, G., Pfitzner, R., Velte, D., 2003: Eco-service Development. Reinventing Supply and Demand in the European Union

Brown, K.A. et al (2000) Economic evaluation of PVC waste management, AEA Technology, produced for European Commission, Environment Directorate.

Crowe, M. et al (2003) Waste from electrical and electronic equipment (WEEE) – quantities, dangerous substances and treatment methods, European Environment Agency.

Danish Government (2004). Waste Strategy 2005-2008, Copenhagen: Danish Government.

Danish Textile & Clothing Exports – 7 biggest markets, 2006. (Accessed via www.textile.dk, 24 June 2006)

de Bruijn, Theo & Norbert Boehm, Vicky eds (2005) Industrial Transformation: Environmental Policy Innovation in the United States and Europe, Boston: MIT Press.

DEPA (1995). Electronics and the Environment – guide to the selection of components, Miljøprojekt nr. 289, Danish Environmental Protection Agency.

DETR (2001) Life Cycle Assessment of Polyvinyl Chloride and Alternatives – Summary Report, London: Department of the Environment, Transport and the Regions.

Directive 2002/95/EC of the European Parliament and of the Council of 27 January 2003 on the restriction of the use of certain hazardous substances in electrical and electronic equipment (RoHS)

Directive 2002/96/EC of the European Parliament and of the Council of 27 January 2003 on waste electrical and electronic equipment (WEEE)

DTB (2001) About the textile and garment branch (In Danish: Om tekstil- og beklædningsbranchen 2001), www.textile.dk (Accessed 06 July 2003)

EC (2000a) Green Paper: Environmental issues of PVC, COM(2000) 469 final, 43 p.

EC (2000b) Mechanical recycling of PVC,

EC (2000c) The influence of PVC on the quantity and hazardousness of flue gas residues from incineration,

EC (2000d) The behaviours of PVC in landfill,

EC (2003) An Economic and Environmental Analysis of the Chlor-Alkali Production Process, produced for the European Commission DGIII.

EC (2003) Proposal for a Directive of The European Parliament and of The Council On establishing a framework for the setting of Eco-design requirements for Energy- Using Products and amending Council Directive 92/42/EEC

EC (2004) Life Cycle Assessment of PVC and of principal competing materials – Final Report, Brussels: European Commission, 325 p.

Ecolabel Companies by Country and Product Group, April 2006 (Accessed 18 September 2006 at <http://ec.europa.eu/environment/ecolabel/pdf/marketing/stats/stats.pdf>)

EEA (2002) Review of selected waste streams: Sewage sludge, construction and demolition waste, waste oils, waste from coal-fired power plants and biodegradable municipal waste. Technical report No 69. European Environment Agency (EEA), Copenhagen

EEA (2003) Europe's environment: the third assessment. Chapter 7 Waste generation and management. State of Environment report No 1/2003. European Environment Agency (EEA), Copenhagen

EEA (2005) Market-based instruments for environmental policy in Europe. EEA Technical report No 8/2005. European Environment Agency (EEA), Copenhagen)

EPE European Partners for the Environment (2002). Multi stakeholder dialogue and vision building. Towards sustainable growth in the textile production-consumption cluster. Executive summary (www.epe.be) (Accessed 15 July 2006)

EU(1996).Directive 96/61/EC concerning integrated pollution prevention and control (the IPPC Directive)

EU Flower Criteria document for textile products valid until 31 May 2007. http://europa.eu.int/eur-lex/pri/en/oj/dat/2002/l_133/l_13320020518en00290041.pdf (Accessed 24 June 2006 at www.ecolabel.dk)

EU pesticide review leads to further product removals, Pesticides News, Quarterly/December 2003 The Journal of Pesticide Action Network UK. <http://www.pan-uk.org/pestnews/pn62/pn62p18a.htm> (Accessed 24 June 2006)

EU-ecolabel (2002). Background document to criteria for textile and clothing EU-ecolabel, http://europa.eu.int/comm/environment/ecolabel/pdf/textiles/background_report_april2002.pdf (Accessed 24 June 2006 via www.ecolabel.dk)

Eunomia (2006). Household Waste Prevention Policy Research Programme. Interim Report, Eunomia Research & Consulting

European Commission (2001) European Packaging Waste Management Systems - Main report. (Undertaken by ARGUS in association with ACR and Carl Bro a/s)

Forman, M.; Hansen, A.G.; Jørgensen, M.S. (2003) The shaping of environmental concern in product chains – analysing Danish case studies on environmental aspects in product chain relations. Paper presented at EGOS (European Group on Organisation Studies) Conference 2003, Copenhagen Business School, 3-5 July 2003, 25 pp.

Gaiker (2006). Assessment of the environmental advantages and drawbacks of existing and emerging polymers recovery processes, Seville: IPTS/EC, 162 p.

Griffiths, Martyn (2006) Vinyl 2010: The Voluntary Commitment Approach of the European PVC Industry to the Challenge of Sustainable Development. Brussels: Vinyl 2010, www.vinyl2010.org

Helvetas (2006). Helvetas organic cotton projects, (http://www.helvetas.ch/wEnglish/organic_cotton/projekte.asp?navid=40) (Accessed 15 July 2006)

Hille, J. (1995) Sustainable Norway. Probing the Limits and Equity of Environmental Space, The Project for an Alternative Future

Hune, A. et al (2000) Implementing Producer Responsibility: Managing End-of-Life Consumables in an IT-service Industry, IEEE,

IDA (2003) Bæredygtig erhvervsudvikling – Et debatoplæg om grøn erhvervs politik og virkemidler med baggrund i historien om PVC (Sustainable business development), Report in Danish, Copenhagen: Danish Engineers Association, 33 p.

ILO (2005) Promoting fair globalization in textiles and clothing in a post-MFA-environment. Report for the discussion at the Tripartite Meeting on Promoting fair globalization in textiles and clothing in a post-MFA-environment, ILO, TMTC-PMFA/2005, Geneva. (Accessed via www.ilo.org 24 June 2006)

Innovative technologies for the economically sound identification and sorting of post-consumer textile (2001)
http://cordis.europa.eu/fetch?CALLER=FP6_PROJ_BRIT&ACTION=D&RCN=46913&DOC=7&CAT=PROJ&QUERY=1147182064870 (Accessed 24 June 2006)

IPPC (2003) Reference Document on best available techniques for the textile industry (adopted 2003). (Accessed via www.epa.ie 24 June 2006)

IPU; DTC & GN (2002). A Designer's Guide to Eco-Conscious Design of Electrical and Electronic Equipment, Institut for Produktudvikling (IPU), Dansk Toxicologisk Center (DTC), and GN-Teknik.

Jones, Martyn and Mohammed Saad (2003). Managing Innovation in Construction. Thomas Telford, London

Jørgensen, M.S. (2003) Some Danish experience with product-service systems and their potentials and barriers to sustainable development, Paper presented at Sustainable Product-Service-Systems: 'state-of-the-art', 1st International Conference, 5th-6th June 2003, De Roed Hoed Amsterdam, The Netherlands.

Jørgensen, M. S., Andersen, M. M.; Hansen, A.G.; Wenzel, H.; Pedersen, T. T.; Jørgensen, U.; Falch, M.; Rasmussen, B.; Olsen, S. I.; Willum, O., (2006) Green Technology Foresight about environmentally friendly products and materials - The challenges from nanotechnology, biotechnology and ICT, Working Report No. 34 2006, Danish Environmental Protection Agency

Jørgensen, Ulrik & Høier, Stine (1995) Erfaringer med substitution af PVC ved renere teknologi og brancheaftale (Experiences with substitution of PVC through cleaner technology and voluntary agreement), Report in Danish, Arbejdsrapport nr. 82, Copenhagen: Danish Environmental Protection Agency.

Kawansson, Nathan and Philippe Roy (2002) Eco labelling as part of corporate strategy, Master thesis, Department of Manufacturing Engineering and Management, Technical University of Denmark, 156 p.

Kemp, René, Munch Andersen, Maj and Maurits Butter (2004). Background report about strategies for eco-innovation. Report for VROM, zaknummer 5060.04.0041. Final version 22 May, 2004

Laursen, S. E., Hansen, J., Andersen, T., and Knudsen, H.K. (2002) Danish experience. Best Available Techniques – BAT – in the clothing and textile industry, Working Report No. 10, 2002, The Danish Environmental Protection Agency

-
- Laursen, S. E., Hansen, J., Knudsen, H. H., Wenzel, H., Larsen, H. F., Kristensen, F. M. (2006) UMIPTX - Miljøvurdering af tekstiler (In Danish) (UMIPTX –Environmental Assessment of Textiles), Working Report No. 3, 2006, Danish Environmental Protection Agency,
- Lewis, H. and Gertsakis, J. with Grant, T., Morelli, N., Sweatman, A. (2001) Design + Environment. A global guide to designing greener products, Greenleaf, 200 pp.
- Manseau, André and George Seaden (eds.) (2001). Innovation in Construction. An International Review of Public Policies. Spon Press, Taylor & Francis Group, London and New York
- Mazzanti, M and Zoboli, R. (2005) Economic instruments and induced innovation: The European policies on end-of-life vehicles. In *Ecological Economics* 58, 318-337.
- McGlade, Jacqueline (2005) Eco-innovation and environmental challenges. Speech to Conference on Eco-innovation: Potentials and challenges of tomorrow's technologies, European Environment Agency, Copenhagen, 19 April 2005
- Miljøstyrelsen (1999) Optimization of PVC-free materials in cables, Arbejdsrapport nr. 24, Copenhagen: Danish Environmental Protection Agency.
- Miljøstyrelsen (2001) Environment and Health Assessment of Alternatives to Phthalates and to Flexible PVC, Miljøprojekt nr. 590, Copenhagen: Danish Environmental Protection Agency.
- Miozzo, Marcela and Paul Dewick (2004). Innovation in Construction. A European Analysis. Edward Elgar, Cheltenham, UK
- Monchamp, A. et al (2001) Cathode Ray Tube Manufacturing and Recycling: Analysis of Industry Survey, Electronic Industries Alliance.
- Monkhouse, Claire and Andrew Farmer (2003) Applying Integrated Assessment to EU Waste Policy. A Scoping Paper for the European Forum on Integrated Environmental Assessment (EFIEA). Institute for European Environmental Policy (IEEP), Brussels
- NEC Projects – Cleaner Technology Program for the Textile Sector of Pakistan (<http://nec.com>) (Accessed 15 July 2006)
- Népszabadság (2004) Banned eco-building? (Betiltott bioépítészet), Newspaper article, 9 July, 2004, <http://www.nol.hu/cikk/324990>
- OECD (1998) Extended Producer Responsibility. Phase 2: Case Study on the German Packaging Ordinance. (ENV/EPOC/PPC(1997)21), Paris: OECD.
- OECD (2000). Innovation and the Environment. OECD, Paris (<http://213.253.134.29/oecd/pdfs/browseit/9200111E.PDF>) (Accessed at June 29, 2006)
- OECD (2004a) Waste Contract Design and Management for Enhanced Waste Minimisation. A Synthesis Report. (ENV/EPOC/WGWPR(2004)3/FINAL). OECD Working Group on Waste Prevention and Recycling
- OECD (2004b). Towards Waste Prevention Performance Indicators. Part 1: Pressure Indicators and Drivers for Waste Generation. Part 2: Response Indicators. Part 3: Indicators Based on Material

Flow Accounts (ENV/EPOC/WGWPR/SE(2004)1/FINAL. OECD Working Group on Waste Prevention and Recycling and OECD Working Group on Environmental Information and Outlooks

OECD (2006). The OECD/EEA database on instruments used for environmental policy and natural resources management (<http://www2.oecd.org/ecoinst/queries/>) (last updated on April 2006)

Patel, J.K. et al (1998) Plastics streams in Germany – an analysis of production, consumption and waste generation, Elsevier: Resources, Conservation and Recycling 44 (1998), 191-215.

Paulitsch, K. (2001) Hess Natur: Acting for the world of tomorrow. Resource management in the textile chain In: Charter, M. and Tischner, U.: Sustainable solutions. Developing products and services for tomorrow, Greenleaf, ch. 23, pp. 381-392

Policy Research Center for Environment and Economy (1999) Impact of Environmental Standards and Requirements in EU Countries on China's Textile Industry

Remmen, A et al (1999) Cleaner technology in the electronics sector (Renere teknologi i elektronikbranchen – in Danish), Miljøprojekt nr. 504, Danish EPA.

Remmen, A., and Ramussen, B. D. (1999) Evaluation of projects carried out under the Environmental Protection Agency's cleaner technology action plans (In Danish: Evaluering af projekter gennemført under Miljøstyrelsens renere teknologi handlingsplaner), Environmental Project no. 502, The Danish Environmental Protection Agency

Robins, N. & Roberts, S (eds.) (1997) Unlocking Trade Opportunities. Case Studies of Export Success from Developing Countries, International Institute for Environment and Development (IIED)

Røpke, I. (2000) Forbrug (in Danish) (Consumption) in: Dansk Naturpolitik (In Danish) Danish Nature Policy, Thematic Report no. 1, pp. 66-81

Rotterdam Convention enters into force, FAO, 24 February 2004
<http://www.fao.org/newsroom/en/news/2004/37667/index.html> (Accessed 24 June 2006)
Rotterdam Convention Secretariat: Website of the Rotterdam Convention Secretariat:
<http://www.pic.int> (Accessed 24 June 2006)

Sara, Balazs, Antonini, Ernesto and Mario Tarantini (2000). Application of Life Cycle Assessment (LCA) methodology for valorization of building demolition materials and products. (<http://www1.coe.neu.edu/~smgupta/4193-56-SPIE.PDF>) (Accessed at June 29, 2006)

Simeone, Maria Gabrielle, Mazzanti, Massimiliano and Roberto Zoboli (2003). Policy-response indicators for packaging waste policy. (ETC-WMF WP 2j) (December 2003)(, ETC-WMF, Copenhagen)

Skou Andersen, M., Brendstrup, S. and Dengsoe, N. (1998) The Waste Tax 1987 – 1996 – an ex-post evaluation of incentives and environmental effects, Working Report from the Danish Environmental Protection Agency, 125 pp. (Available at www.mst.dk)

Søndergård, B., Hansen, O.E. and Holm, J. (2004) Ecological modernisation and institutional transformations in the Danish textile industry, Journal of Cleaner Production, Vol. 12, pp. 337-352

Stavins, Robert (2001) Experience with Market-Based Environmental Policy Instruments, Regulatory Policy Program Working Paper RPP-2001-11. Cambridge, MA: Center for Business and

Government, John F. Kennedy School of Government, Harvard University
(<http://www.ksg.harvard.edu/cbg/research/rpp/RPP-2001-11.pdf>) (accessed at June 29, 2006)

Stranddorf H., Forman M., Nielsen A. and Sjøgaard M. (2002) Environmental, ethical and work environmental demands in the textile product chain. (In Danish: Miljø-, etik og arbejdsmiljøkrav i tekstilproduktkæden). Environmental Project no. 681, Danish Environmental Protection Agency, 165 pp. (Available at www.mst.dk)

Sustainable Agri-Food Production and Consumption Forum: UNEP's RESPONSES - Rotterdam Convention on the Prior Informed Consent (PIC) <http://www.agrifood-forum.net/response/pic.asp>. (Accessed 24 June 2006)

Tanasescu, I. (2005) Voluntary instruments in EU environmental policy. Paper prepared for the 2005 Berlin Conference on the Human Dimension of Environmental Change "International Organisations and Global Environmental Governance, Berlin-Potsdam, 2-3 December 2005.

Thai Textile Export (2003) Thai Garment Export 2002. TTIS Textile Digest, January 2003, p. 21-22

The European Container Glass Federation (FEVE) (2006) Western European Glass Recycling: 2004 (<http://www.feve.org/index.php?option=content&task=view&id=20&Itemid=51>) (accessed at June 29, 2006)

Tojo, Naoko; Lindhquist, Thomas and Dalhammar, Carl (2006) Extended producer responsibility as a driver for product chain improvement. In Scheer, Dirk & Rubik, Frieder eds Governance of Integrated Product Policy. Sheffield: Greenleaf Publishing, pp. 224-242.

Tucker, Arnold et al (1999) Chemical Recycling of Plastics (PVC and other resin), TNO-report STB-99-55, produced for European Commission, DGIII.

Vaz et al (2001) Reporting on environmental measures: Are we being effective? European Environmental Agency, Environmental issue report No. 25.

Walls, Margaret (2006) EPR Policies and Product Design: Economic Theory and Selected Case Studies, Working Group on Waste Prevention and Recycling, OECD, Environment Directorate.

Walters, A., Santillo, D. and Johnston, P. (2005) An overview of Textiles Processing and Related Environmental Concerns, Technical Note: 08/2005, Greenpeace Research Laboratories, University of Exeter

Wenzel, H., Knudsen H. H., Sójka-Ledakowicz, J., Machnowski, V., Koprowska, J., Grzywacz, K., Hansen, J., Birch, H., Pedersen, B. M. & Jozwik, A. (1999) Cleaner Technology Transfer to the Polish Textile Industry, Danish Environmental Protection Agency

Wenzel H, Niki Bey, Ole Willum, Alejandro Villanueva, Marko Vrgoc (2006). Environmental benefits of recycling. An international review of life cycle comparisons for key materials in the UK recycling sector. 2006. Waste & Resources Action Programme, UK.

Woolridge, A. C., Ward, G.D., Philips, P.S., Collins, M. and Gandy, S. (2006) Life cycle assessment for reuse/recycling of donated waste textiles compares to use of virgin material: An UK energy saving perspective In: Resources, Conservation and Recycling, vol. 46, pp. 94-103

7 CONCLUSIONS AND RECOMMENDATIONS

This last chapter collects the most important results and conclusions from the previous chapter and provides the recommendations resulting from the experiences from using the different theoretical approaches, utilising the available statistical data on waste, applying a lifecycle approach to waste prevention policies and their impacts, and analysing the effectiveness of different waste-related policies and their interaction with innovation.

The chapter is starting with an overview of the collected data about waste streams in EU25 and about the projected trends until 2020 followed by a presentation of the suggested priorities of waste materials and waste streams based on assessments of the environmental potentials from prevention and compared to the existing material and energy supply and waste treatment. The policy analysis and the lessons from the studies made are then presented. The chapter is finalised with the methodological conclusions from the project based on the methodological experiences from the project and applicable as some reflections for future similar studies.

7.1 Waste streams in EU25

The study has collected data for waste generation levels in the EU-25 based on what has been reported into the existing international waste data systems. Table 7.1 (identical to table 3.2) shows the estimates of the present waste flows.

Table 7.1: Estimation of total yearly load from certain sources or of certain waste streams in the EU

Waste type	Range (kg / capita / year)	Weighted average (kg/capita / year)	Percentage of EU population that the available data covers	Calculated EU-25 generation (Million ton/year)
Municipal Solid Waste	260 – 753	531.22	100	242.9
Manufacturing	7.6 – 3188	1064	98.7	381.6
Textile and Leather	2.6 – 102.8	18.00	77.1	8.23
Textile and Leather HZW	0 – 1.47	0.45	60.0	0.21
Construction and demolition	2.59 – 5580	1092	84.9	499.4
Mining and quarrying	2.58 – 6064	823.0	84.6	376.3
Energy production	2.5 – 880.1	201.5	63.7	92.1
Energy production HZW	0.25 – 13.02	1.49	35.3	0.68
Waste from Agriculture	7.41 – 14074	1318	40.3	602.6
HZW from Agriculture	0.1 – 3.9	0.31	32.7	0.14
Waste oil	1.1 – 30.9	7.71	89.3	3.52
Sewage sludge	2.39 – 105.6	27.54	99.2	12.59
Hazardous waste	4.1 – 5581	127.2	100	58.16
Packaging waste	12.04 – 211	172.5	88.2	78.87

Obviously, the coverage of countries, and the resulting quality of information generated is dependent on the data quality available: The waste data systems suffer from gaps and from inconsistency in waste categorization – even on national level from year to year. In general waste statistics historical data are more comprehensive for EU15 than for the EU10. To a limited extent it has been possible to filter obvious errors, and to fill the gaps, and relatively reliable EU-25-level waste stream data are presented.

A model-based projection based on a baseline and a low-growth scenario has been used to predict future generation rates, where possible for EU-25, up to app. 2020 for eight different waste streams, which however are different from the way that the waste statistics above are organised. The projections show the following future trends:

- Municipal solid waste: An increase of 15-25%
- Biodegradable waste: Reduction since waste is being diverted away from landfill
- Industrial waste: An increase by 45-65% - depending on the scenario
- Construction and demolition sector: An increase of 15-35 % for EU-15 with big differences among the countries - depending on the scenario
- Paper and cardboard: An increase of 40-65% - depending on the scenario
- Glass: An increase of 25-45% with big differences among the countries – and depending on the scenario
- Packaging: An increase of 15-25% for EU-15 – depending on the scenario
- Tyres and waste oil: Modest increase in EU-15, but an increase of 70-75% in EU-10.

No detailed information on the material characteristics of the waste is available in the waste statistics, and this information is necessary to do the adequate assessment of the environmental impact of the waste to be able to assess the environmental aspects of waste generation and of prevention actions. To overcome the jump from waste streams to materials and resources, a correlation has been developed between materials and the studied waste flows.

The collected statistical data shows that it is a problem for the shaping and assessment of policy impact that the statistical data are so in-coherent among different countries. It is not clear when waste is ‘called’ waste and when waste is re-defined as products and thereby indicating a false prevention action also when comparing data over time.

7.2 Prioritization of waste streams from their environmental impact

In order to identify waste materials and waste streams, which from an environmental perspective should be of main concern for prevention through policy intervention, the potential environmental impacts of waste materials have been characterised. This material approach is necessary as a first step to analyse environmental potentials from waste prevention because the effects of preventive actions spread through the whole life cycle of a material, stream or product, including the energy and material supply, and the waste treatment.

The material approach has therefore been a first step creating ‘*building blocks*’ of waste materials, which have been used in an assessment of environmental potentials from prevention at waste stream level, where waste streams containing a mixture of different materials are assessed according to their estimated content of the examined materials.

7.2.1 Conclusions at waste material level

When all upstream and downstream processes are covered, it is possible to compare whether it is the prevention of, for example, wasted metals, plastics, wood, organic matter, or paper that

potentially avoids the largest environmental impacts. Such comparison is, however, conditioned by the energy and material supply, and the waste treatment. For instance, if the present (or future) treatment is not land filling, but incineration with heat recovery or recycling, then the savings obtained by prevention are not the same. The results obtained illustrate that the materials have quite different intensities of energy and resource use and also different potentials for savings through waste treatment like recycling and incineration. Based on an assessment of resource loss, energy consumption, hazardousness, and amounts a grouping of waste materials can be made. Three groups of materials can be distinguished – with the group with the highest potential from prevention first:

- The first one comprises aluminium and plastics. These materials are very resource and energy intensive, and also have high recovery potentials through recycling and/or incineration.
- The next group is composed of cardboard, paper and steel, with medium intensities of energy and resource consumption, and medium potentials from prevention.
- The last group comprises organic matter, glass, textiles (natural and synthetic) and construction mineral materials and wood.

Quantitative prevention actions should preferably address the materials, which because of their amounts in Europe rank high in the priority list: mainly minerals, cardboard, paper and organic materials. Such prevention actions affect the energy use and the resource use associated with the use of these materials. Glass, textiles and wood should also mainly be tackled through quantitative prevention (to reduce the amounts used), since their hazardousness concerns are low.

Qualitative prevention actions should focus on materials which rank high because of their hazardousness concerns: mainly aluminium, iron and plastics.

The material list used in this project has been restricted to 11 materials, but chemicals with strong toxicity impacts such as pesticides, detergents, organic solvents, plasticizers as well as heavy metals would be candidates to material substitution, had they been included. Quantitative prevention in the materials should also focus on the substitution of the additives which result in hazardousness during use, disposal or production (e.g. Bisphenol A, flame retardants and softeners in plastics, heavy metals, some textile dyes and waste oils in scrap, impurities in aluminium).

7.2.2 Conclusions at waste stream level

Waste streams are combinations of waste materials. In this study, a list of waste streams has been selected for further analysis:

- Total municipal solid waste
- Total manufacturing waste
- Textile and leather
- Textile and leather (hazardous waste)
- Construction and demolition
- Mining and quarrying
- Energy production
- Energy production hazardous waste
- Agriculture waste
- Agriculture (hazardous waste)
- Waste oil
- Sewage sludge
- Total hazardous waste
- Packaging waste

The methodological approach is based on the use of the material-based impacts, combined with the content of the studied materials in the streams, which is assumed constant. In this way, the environmental impact profile of each waste stream has been calculated, and then multiplied by the total generation of the stream in the EU25, using six different waste treatment scenarios (two for incineration without and with energy recovery, three for landfill without methane collection and with methane collection without or with energy recovery, and one for recycling).

When assessing waste flows the following seems to be of particular environmental concern *per weight unit*:

- Total municipal solid waste
- Textile and leather (hazardous waste)
- Hazardous waste from agriculture
- Recycling of sewage sludge
- Waste from energy production and hazardous waste

When looking at the EU25-level, five waste streams contribute particularly to environmental impact. These are total municipal solid waste, total manufacturing waste, construction and demolition waste, mining and quarry and waste from agriculture.

For resource consumption, the same waste streams dominate with the inclusion of textile and leather, energy production waste, hazardous waste and packaging waste.

When combining with a hazardousness indicator the following waste flows are of particular concern:

- Total municipal solid waste (contributes considerably to both environmental impact, waste generation and resource consumption as it has a high hazardousness score)
- Total manufacturing waste
- Mining and quarrying
- Energy production waste
- Hazardous waste

From a waste prevention point of view, actions directed towards these waste streams would have the biggest environmental potential.

The following more general recommendations can be made from these environmental assessments:

- Generally, the production (and extraction of raw materials) stage bears a significant part of the environmental impact in the life cycles of the materials and in the products considered in the cases. Therefore, in general, the more directly a product or material can be re-used the less environmental impacts are caused.
- After prevention recycling seems for all materials to be the second best environmental option, whereas it is not clear whether incineration or landfill is the third best option. This is highly dependent on whether or not the incinerator applies energy recovery. Waste prevention policies and actions will therefore be most environmentally effective if applied where materials are not recycled to a large extent.
- Aluminium has a high environmental impact potential regardless of the waste management option. Policies and actions to prevent aluminium waste are therefore environmentally beneficial.
- Organic waste contributes significantly to nutrient enrichment, primarily in the production stage. Therefore prevention of organic waste in all life cycle stages would result in environmental improvement
- Textiles are products where waste prevention would have an impact since both land filling and incineration has considerably higher impact potentials than recycling.

It should be emphasised that the assessments made are based on assessment of materials and does not include the use stage of the products in which these materials are used. When shifting the assessment from materials to products or waste streams, a more specific assessment may be necessary for specific product groups to ensure that no sub-optimisation is introduced due to the exclusion of the use stage. For example, this could be the case if the material weight of a given product is decreased resulting in a decrease in quality causing a shorter life time and a higher throughput rate and therefore also more waste.

The fact that the environmental benefits from waste prevention depends on the material and energy supply (types of raw materials and energy sources) and the waste treatment of the involved regions or countries implies that the environmental benefits from waste prevention will be different in different countries in EU25 representing different archetypical situations. Countries with big focus on land filling will have higher improvement potentials than countries with a higher degree of recycling and for some waste streams also compared with incineration. Countries which, according to the projected trends, are supposed to get a higher growth within certain consumption or product areas will also have a relative higher environmental potential from waste prevention. For some areas the growth in EU10 is expected to be higher than in EU15, which implies that the prevention potentials for these areas increase more in EU10 than in EU15. Since the use of hazardous materials and chemicals may be bigger for some product areas in EU10 than in EU15, the potentials from qualitative prevention, where the use of hazardous materials and chemicals is avoided, may be bigger in EU10-countries. Qualitative prevention may also be a prerequisite for enabling waste minimisation through recycling, because handling of hazardous materials in waste streams are avoided.

7.3 Waste policies and innovation

This part of the project has been focussed on how waste policies have affected the dynamics of innovation in the broad sense including technical, social, and market innovations. For waste prevention policies and other waste related policies to be efficient they must address a number of different aspects of the upstream processes of design, manufacturing, and use of products and influence decisions made long before the products ends up in a waste stream. This includes affecting actors also in the very early parts of the product chain.

7.3.1 Effectiveness of policies

The EC policy on **electronics** comprises of two main directives: WEEE and RoHS, which in combination with the new directive on the design of energy using products form a coherent and complementary policy pattern. The overall conclusion is that this set of policies demonstrates a relevant mix of goals, specific policies on hazardous substances and measures to handle the waste demonstrating an effective policy pattern, though the impact on product design and waste prevention concerning the growth in this waste stream can be questioned as the specific way that the new extended producer responsibility regime has been institutionalised focus more on shifting the costs of waste handling to the producers and importers than to waste prevention actions.

The policies introduced in the handling of a material like **PVC** have in contrast to the relative success of the electronics waste policies been much less effective. The question is whether the policies focused on regulating the use and disposal of PVC have met the anticipated goals and have been implemented in a productive way. One important lesson to be learnt is the rather substantial influence that industry can have on the policy processes, especially in cases where the problems and uses are complex. It is also obvious that the policy processes ending in a 'limbo' state do counter the utilisation of even obvious and useful innovations, which points to the need for overall policy goals. While industries' primary concerns have been on the use of PVC in building construction and for industrial uses, the presented alternative based on collection and reuse or recycling has

functioned as a dead-lock for other policy initiatives. These recycling activities have never demonstrated any efficient return rates nor have they resulted in well defined reuse of PVC due to the use of additives containing heavy metals and brominated flame retardants.

As the pollution generated along the life cycle of **textiles** only in a limited scale is visible in the waste streams from households, the waste prevention policy of the EC demonstrates a limitation when it comes to the growth of wastes based on a growth in consumption. The environmental assessment shows that in comparison with other materials, textiles per weight unit have a significant contribution to environmental impacts and prevention directed at avoiding hazardous chemicals in waste for land filling and incineration would be environmentally beneficial. The waste from the textile life cycle is coming from the complete cycle of production and use, and some of the waste components especially focused upon have been in the production of raw materials and products rather than in the post-consumer wastes from used textile products. Waste prevention policies lack a more dedicated focus on the IPP aspects of consumption, including product chain oriented policies that can help avoiding the export of production related pollution – and even use of outdated polluting production methods – in the upstream companies often located outside Europe. The consumption is increasing due to the ongoing changes in fashion where clothes often become ‘morally’ too old before they are ‘technically’ too old. There are only few examples of reduction of the consumption of textiles and clothes through extension of life time of products through more ‘lifelong’ design and through organisation of product–service systems. The ongoing and future REACH implementation needs to address the upstream use of chemicals and the impacts from manufacturing – including manufacturing in developing and newly industrialised countries - on the use and the laundry phase in the European countries.

The use of waste charges as the dominant regime in the attempt to reduce the large amounts of **building wastes** to improve reuse and recycling as a more feasible and attractive alternative for waste handling companies has turned out to be a very effective policy instrument. These economic instruments have – even over few months – changed the waste streams away from depositing to alternative uses. While the regulatory regime turns out efficient, the content of eventual hazardous and polluting fractions of building wastes is difficult to control. At the same time the overall policy patterns in the building construction sector has been diverse and even though effort has been made to improve environmentally friendly design of buildings only few results are shown and mostly in more experimental buildings where dedicated constructors have demanded e.g. ecologically improved buildings. With the relatively long product life cycles in the building and construction sector, it seems wise to have a dual focus in the policy of building and construction waste, where one focus is on improving the technological development of existing technologies in the short term, and another focus is on developing and using new environmental friendlier materials and assembly processes for building and construction in the long term.

In the area of **packaging waste** the reuse and recycling of aluminium beverage cans and glass bottles including deposit-refund schemes are effective in achieving waste prevention and minimisation goals. Their effectiveness, though, is dependent on the specific institutional implementation made for the recycling systems and on limiting the different types of beverage packaging. Also the few examples of general packaging policies based on distributors and producers responsibility and take-back of packaging materials as e.g. the German ‘Dual system’ have turned out to be quite effective in reducing the amount of waste and also improving procedures for recycling and reuse of packaging materials. One of the more general impacts of the focus on packaging waste in policy strategies and information campaigns has been a reduction in the use of polluting types of packaging materials as e.g. the reduction in use of PVC for packaging. This has resulted in making packaging materials easier to recycle or incinerate.

At the **general level** it is observed that most successful environmental improvements in industry are to be found in the cases where government has played a consistent part by setting goals and

timelines for improvements, by funding or in other ways supporting innovative changes, by setting taxes providing significant changes in cost structures, or by intervening with traditional legal requirements. In those cases where declared government policies were not followed by other supportive measures or even just the threat of future intervention in case of non-compliance with the policy objectives, not much happened.

There are big expectations to effectiveness of single instruments, but the analyses show that waste prevention policy instruments very seldom are the only programme influencing a certain product area. There are often other, and conflicting, policy goals and maybe counter-programmes from industry, like recycling schemes which aim at hindering material substitution (like for PVC). Such continuously unsolved policy controversies prohibit comprehensive results.

Several of the introduced policy regimes can – if implemented in accordance with the experiences and basic characteristics of their way of involving actors and creating incentives – turn out as very effective instruments to support the waste prevention and waste minimisation strategies. These include the use of:

- extended producer responsibility when addressing and defining incentives adequately for the core actors in the product chains,
- rather traditional policy measures based on banning of substances or setting finite goals for their substitution, and
- economic charges defined at a specific level and followed by necessary specific definitions, measuring procedures, and control and enforcement structures.

These instruments in combination with overall goals to be communicated widely have demonstrated to contribute when the specific conditions for their design and implementation are respected as they all demand certain conditions to become effective as shown in the case studies.

The problems related to the difficulties of enforcing the definition and concept of waste prevention strategies asks for actions at several levels. There is need to clarify the interpretations of reuse and thereby the borderline between waste and products for reuse. The new regimes introduced weaken the national environmental authorities and their enforcement structures – if in place – and opens for a need for clarifying the specific responsibilities in the future.

7.3.2 Waste prevention and innovation

When summing up the results from the case studies to identify more general conclusions about the interaction between waste minimisation policies and innovation it turns out rather clearly that:

- waste prevention and waste minimisation policies as such do not prove to have had a limiting effect on innovations, and that
- policies in these areas have created incentives for and also set directions for innovations, but if limitations have shown they more seem to relate to a lack of consistency in how the policies have been defined and enforced.

On the other hand:

- waste minimisation policies are not per se encouraging innovations as they often impact products at a phase in their life cycle ‘distant’ from the responsible designers and producers, and more importantly
- even policies explicitly addressing extended producer responsibility are only efficient in creating incentives if they are designed in a way, which addresses the design and production to prevent waste generation and the related environmental impact.

These general conclusions are though based on the limited empirical material collected in the cases due to the lack of data from international, comparative evaluations of the impact of waste

prevention and waste minimisation policies. But it must also be recognised that the studies needed do are not easily produced.

Waste minimisation can basically have two different perspectives. One perspective is the prevention of product waste by prolonging the life time of the product. The other perspective is the prevention of waste during the production of a product, so that the product itself becomes 'cleaner' or the production of the product has less environmental impact.

Many initiatives are not widely disseminated, but only implemented in some countries and among some frontrunner companies, maybe involved in a project or programme. The impact of waste prevention policies is therefore not only dependent of the effectiveness of the measures used and their coordination but also on the dissemination of the policies throughout Europe. This include the need for new mechanisms and methods to control and enforce the waste prevention policy aims especially in relation to trans-border and global trade of products/waste in the 'grey zone' created through the involvement of a large number of new actors as is the case in the implementation of extended producer responsibility regimes. Continued negotiation with and pressure on industry concerning the need for setting goals for eco-design and the need for waste prevention seems to be important for producing a positive impact of waste minimisation policies on innovation.

Very few policy instruments and supported efforts are focusing on limiting the amount of product waste by prolonging the life time of the product through 'social innovations' and 'market innovations' including the development of new product-service systems with changing responsibilities based on altered systems of distribution, ownership, and maintenance, which could include upgrade and repair of products. This strategy could work with many different types of products like products within all five cases EEE products, textiles, building and construction, PVC and packaging. For products based on global product chains this strategy is a challenge, unless the products are based on strong brands, like cars, where more closed product/service systems exist. Such user-producer relations may increase the knowledge of the producer about the actual use of the products and thereby support the development of more user-oriented innovation strategies, which may be more competitive in a global economy, at least for SMEs.

7.3.3 Waste prevention and environmental impacts

Waste prevention is an important policy field, because of the resource consumption and environmental impacts during production, which so to say are embedded in a product. Also the increasing amounts of waste and the problems connected to land filling and incineration point to waste prevention initiatives as important measures. However, the global production and distribution structures and the growing amount of cheap, but complex consumer products (like electronic products) make waste recycling a challenge, since it is expensive to disassemble and reuse components at their original manufacturing production site. In stead grey-zone export of expired, maybe partly functioning products, to poorly equipped facilities in poor countries are taking place as so-called product export. This calls upon waste prevention through extended product life time at the consumer stage. However, implementation of such measures calls upon new strategies for product design, new market strategies in industry and higher prices on consumer products reflecting the environmental impact of the product. Existing examples of more closed product loops are companies leasing products like copiers and a few examples of repair facilities for electronic products and textiles.

Data about economic costs and benefits of waste prevention actions for authorities, consumers and industry has not been found. Most data concerns the use of economic incentives in encouraging industry to other types of waste management, for example encouraging recycling and construction waste by increasing the costs for land filling. However, the economic instruments are not the only instrument needed to ensure changes in the waste generation or waste management. For example,

the changes in handling of construction wastes in a number of countries seem to be a result of several interacting instruments:

- An agreement with the national demolition association on selective demolition of building materials,
- Public funding for R&D in cleaner products and technology in the waste treatment sector,
- The use of economic instruments (e.g. landfill/waste tax) in the waste treatment sector, and
- A ban on land filling of some waste fractions

The self-regulating potential of economic instruments has also been questioned by the EU in relation to the EUP-directive, where self-regulation is not seen as a feasible option, in particular in sectors where the market is very fragmented. This is relevant for energy-using products, given the size and lack of homogeneity of the sectors involved; it cannot be expected that credible and coherent voluntary actions of the economic operators to address environmental aspects of energy-using products throughout their life cycle will emerge spontaneously.

Establishment of waste prevention may imply some initial costs to authorities in terms of a waste prevention programme for supporting industry in developing and implementing waste prevention options. However, these costs are small compared to the potential, future costs from environmental impacts from leaking land fills, contaminated waste water sludge etc. and from the numerous impacts caused by the extra volume of materials which must be produced in the absence of waste prevention. In relation to eco-labelling there has been a discussion whether companies applying for and utilising an eco-labelling license should pay for this (as they do at the moment) or whether it rather should be companies not applying an eco-label that should pay, for example via a redistribution of taxes from waste management, waste water treatment etc.

7.4 Methodological conclusions

An important contribution from the study has been to assess and present a conceptual framework comprising waste treatment practices and a methodology to assess the potential of waste prevention to reduce environmental impacts of different waste streams.

7.4.1 Policy analyses

One of the fundamental questions raised in the project has been the impact of waste prevention policies (and also waste minimisation policies) on innovation and in a broader sense the interrelations between innovation and waste creation and how especially waste policies influence this relationship, but also how waste policies might cross act with other fields of policy that directly or indirectly impact on the creation of and hazardousness of waste and the types of innovations that influence these.

The implementation and the impacts of policy interventions are difficult to study. Not least because specific policy interventions most often do not stand alone, but are influenced by on one hand the policy discourse itself and the views and intentions expressed herein, on the other hand by other policy instruments with different objectives. Overlapping policies coming from other fields of policy with than waste prevention and different objectives or even counter measures installed by other involved actors may turn as powerful as the policy actions selected for study in this context.

The role of the institutional framework and the translations resulting from moving from the policy discourses and objectives to the choice of regulatory framework and again to the 'street level' implementation should be handled in an analytical framework focusing on the constitution of 'regulatory regimes'. In the cases where different policy measures are used in combination they can be characterised as a policy pattern.

Waste prevention and waste minimisation policies and their shaping and impacts have been studied in two ways. Firstly through an analysis of waste prevention actions earlier identified in studies by OECD and EEA, and secondly through five cases which represent different targets of environmental regulation: product, material, waste stream, consumption and sector. In both analyses the focus has been on identifying timelines, the policy regimes around policy instruments and interaction between policy regimes into policy patterns. However the availability of data has not always enabled to establish the 'ideal' analyses. There are very few analyses, where waste statistics have enabled analyses of the changes in the amount or hazardousness of waste streams parallel to the implementation of a certain policy regime. The available information about the policy regimes in the studies by OECD and EEA is very limited, which also has limited the ability to make analyses of policy mechanisms based on these studies. The five case studies about electronic products, PVC, textiles, packaging and construction and demolition have been based on analyses of policy patterns and the involved policy regimes, but the links to changes in waste materials and waste streams has only been possible for some parts of the analyses and international comparative analyses have only been possible at a qualitative level. The lack of appropriate data shows the need for much more analyses of the shaping and implementation of environmental policy regimes and the environmental impacts and the interaction with for example innovation policies and dynamics. Such analyses could support future co-shaping of waste related policies and innovation policies in order to ensure a focus on innovation in waste related policies and on the future waste generation from innovation at various levels, for example from the development within nanotechnology.

7.4.2 Assessments of environmental impacts

In the assessment of environmental impacts of waste materials and waste streams it is recommended to use a life cycle perspective, even though the assessment of waste flows is not simple since waste flows are composed of many fractions each holding a specific environmental impact potential. This is why performance indicators used in waste management often do not address the potential environmental impact but merely report on waste amounts. The recommendation is to break down the waste flows into materials and perform the analysis on these in a life cycle perspective. Most often this makes sense since waste prevention considers substances, products or materials.

Three approaches are proposed, and these can be used separately or in combination depending on the purpose of the assessment:

- A full life cycle impact assessment will be suitable if an assessment of a specific action is wanted and will provide a detailed overview of the impacts. The advantage is the freedom in setting system boundaries and in selecting impact assessment methodologies, data base etc - this can on the other hand restrict the decision making power since a single study will be sensitive to the choices made for that study. The amount of work is substantial, not least if regional or national conditions for material or energy supply, transportation etc. should be reflected in the data used in the life cycle assessment.
- A literature review with interpretation of the results to fit the specific action may be the chosen approach in the case where the concerned waste stream is well investigated. The advantage is a broader perspective and less sensitivity to the choices of a single study. However, care must be taken to evaluate e.g. system boundaries and other choices made by the conveyors of the different studies. Furthermore, the results can sometimes not be expressed in impact scores but only as relative impacts (related to the other studies evaluated). There is also the more time consuming path to analyse and extract the inventories from already published studies. These will however, most often not be provided in detail for each single process but only for whole or parts of systems if published at all, which means that some of the choices made by the original study conveyor will be taken over. A literature study may qualify the results obtained from performing a LCA.

-
- Simplified indicators can be used for the purpose of an environmental ranking of different waste streams or a first consideration about the potential impact connected to a waste material or to a waste stream. The purpose is to aggregate different pressures into overall impact categories and thereby with a limited amount of indicators to express the environmental impacts of a system. Three simplified, life-cycle based, environmental indicators are recommended:
 - An *energy indicator* – because all extraction, manufacturing and waste treatment processes require or release energy, and this indicator captures the magnitude of the reduction of the use of energy that for saved through prevention in the life cycle of the material compared to the existing waste management.
 - A *single resource indicator* – to enlighten the magnitude of the reduction of the use of materials from virgin sources that is achieved by prevention compared to the existing waste management, i.e. the magnitude of the impacts associated to raw material extraction and refining - being divided into energy and material resource volumes weighted in relation to their relative scarcity.
 - A *hazardousness indicator* reflecting potential risks related to toxicity and other hazardous properties and occurrence that can be avoided through prevention. The indicator of hazardousness is in this study constructed as a qualitative scoring method.

The methodology presented reflects that life cycle assessments are used as method in many cases. However, the available data does not always allow for comprehensive assessments, which may cause controversies among stakeholders within a policy field about lack of data, data quality, system boundaries etc. Life cycle assessments should not be seen and used as ‘black-boxed’ expert tools, but as tools for dialogue about mutual recognition of data quality, system boundaries etc. A strong policy pressure will be necessary to create a ‘feeling’ of urgency among the stakeholders. There may be cases where life cycle thinking based on qualitative assessments will be enough to create a picture of the problems and policy options to be considered.