

Open-cycle indirectly fired gas turbine for wet biomass fuels

Elmegaard, Brian; Qvale, Einar Bjørn; Carapelli, G.; deFaveriTron, P.

Published in:

Proceedings of Efficiency, Cost, Optimization, Simulation and Environmental Impact of Energy Systems

Publication date:

2001

Document Version

Early version, also known as pre-print

[Link back to DTU Orbit](#)

Citation (APA):

Elmegaard, B., Qvale, E. B., Carapelli, G., & deFaveriTron, P. (2001). Open-cycle indirectly fired gas turbine for wet biomass fuels. In Proceedings of Efficiency, Cost, Optimization, Simulation and Environmental Impact of Energy Systems (pp. 361-367). Istanbul: International Centre for Applied Thermodynamics.

DTU Library

Technical Information Center of Denmark

General rights

Copyright and moral rights for the publications made accessible in the public portal are retained by the authors and/or other copyright owners and it is a condition of accessing publications that users recognise and abide by the legal requirements associated with these rights.

- Users may download and print one copy of any publication from the public portal for the purpose of private study or research.
- You may not further distribute the material or use it for any profit-making activity or commercial gain
- You may freely distribute the URL identifying the publication in the public portal

If you believe that this document breaches copyright please contact us providing details, and we will remove access to the work immediately and investigate your claim.

Open-cycle Indirectly Fired Gas Turbine for Wet Biomass Fuels*

Brian Elmegaard[†], Bjørn Qvale, Giacinto Carapelli[‡] and Pietro de Faveri Tron[‡]
Department of Mechanical Engineering
Energy Engineering
Technical University of Denmark
DK-2800 Kgs. Lyngby
Denmark

Abstract

The Open Cycle Indirectly Fired Gas Turbine (IFGT) allows a wide range of fuels, solid, liquid or gaseous, to be used. The present study concerns the utilization of biomass fuels.

In an IFGT the exhaust from the turbine is used as combustion air. The internal combustion chamber is replaced by a heat exchanger heating the air from the compressor, thus eliminating the flow of flue gas through the turbine.

A wood fired IFGT was chosen as reference case. It was found that for this reference, only a low efficiency (below 30% for $TIT = 1100^\circ\text{C}$) may be obtained. The main reasons for this is that the exhaust temperature to the stack is high and that the fuel has a high water content (50% on wet basis). This suggests that the performance could be improved, by adding a fuel dryer driven by the flue gas. This study shows that this does improve the efficiency of the cycle dramatically. However, the flue gas enthalpy still is not fully utilized.

This suggests that this system could be used for disposal of still cheaper waste fuels with even higher water content, such as sewer sludge. Calculations show that fuels with a water content of up to 80% may be used. At this point the efficiency on lower heating value basis increases to 50.5%. Equally interesting is, that the efficiency on higher heating value basis is close to 25% for all water contents of the fuel.

Nomenclature

| | | | |
|------------------|--|------------------|---|
| η | Efficiency [-] | Δp_{tot} | Total pressure loss in cycle [bar] |
| $\eta_{is,c}$ | Compressor isentropic efficiency [-] | PR | Pressure ratio [-] |
| $\eta_{is,t}$ | Turbine isentropic efficiency [-] | ΔT_{min} | Minimum temperature difference in heat exchanger [$^\circ\text{C}$] |
| $HHV_{received}$ | Net calorific value as received [MJ/kg] | τ | Temperature ratio [-] |
| λ | Excess-air ratio [-] | T_{stack} | Stack temperature [$^\circ\text{C}$] |
| LHV_{dry} | Gross calorific value on dry basis [MJ/kg] | TIT | Turbine inlet temperature [$^\circ\text{C}$] |
| $LHV_{received}$ | Gross calorific value as received [MJ/kg] | y_{Cl} | Volume fraction of chlorine [-] |
| | | y_S | Volume fraction of sulphur [-] |

* This paper has appeared in Proceedings of ECOS 2001, July 4-6, 2001, Istanbul, Turkey, pp. 361-368

[†]Corresponding author, Phone +45 4525 4169, fax: +45 4593 5215, email: be@mek.dtu.dk

[‡]Giacinto Carapelli and Pietro de Faveri Tron are exchange students from the University of Florence, Italy

1 Potential of the IFGT

The power generation field is dominated by conventional Rankine steam power plants. Such power plants

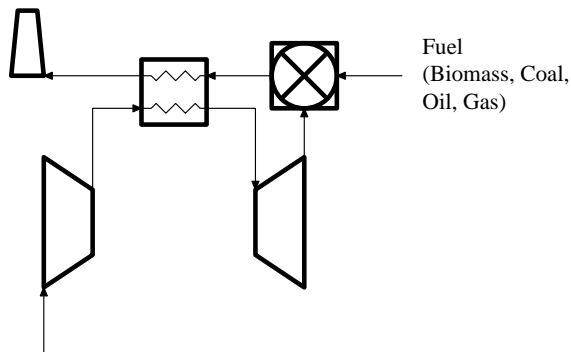

Figure 1: Simple-cycle IFGT

are usually quite big. At smaller sizes their efficiency fall and the costs rise.

Biomass is a resource that is spread out quite thinly, over geographically large areas. Transportation therefore is a potential problem. For this reason generation of power from biomass should preferably take place in decentralized power stations, that are smaller than what is usually considered economically and thermodynamically advantageous for the steam Rankine cycle. This is a power range in which the gas turbine becomes interesting.

However, a normal gas turbine cannot run on solid fuels. Therefore, the biomass will either have to be converted to gas through gasification or utilized in an Indirectly Fired Gas Turbine. A schematic of a simple IFGT is shown in figure 1. The cycle is based on a gas turbine engine with compressor and expander, but with the combustion chamber replaced by a heat exchanger transferring heat from the combustion products to the compressed air from the compressor. The combustion takes place externally to the gas turbine and uses the turbine exhaust as combustion air.

In the present study, a modified IFGT process running on a range of biomass fuels with different water content has been studied. The process has been optimized using the simulator DNA [Elmegaard, 1999]. DNA is a flexible tool allowing parameter studies and process synthesis to be carried out easily. The models may easily be extended for part load and dynamic simulation.

2 Background

From the literature it appears, that the open-cycle indirectly or externally fired gas turbine, mainly has

been studied as a process for utilizing coal in gas turbines. Biomass has mainly been considered as a fuel for conventional boilers and for IGCC's or gas engine plants, both requiring the fuel to be gasified [Beenackers, 1993, Obernberger, 1998]. The studies of the IFGT have focussed on the improvement of the cycle by construction of a heat exchanger applicable at very high temperature, above 1500°C. The studies have focussed on ceramic materials for construction of the heat exchanger or, alternatively, a regenerator [Pratt, 1999, Ferrato and Thonon, 1997, Solomon et al., 1996, LaHaye and Bary, 1994].

Other studies have focussed on the application of the IFGT in Combined Heat and Power Plants (CHP) [Edelmann and Stuhlmüller, 1997, Eidensten et al., 1996, Ruyck et al., 1994] for public utilities or in industrial applications using the heat for generation of steam or drying of raw material for industrial processes [Evans and Zaradic, 1996].

A considerable number of studies on closed-cycle externally fired gas turbines have been reported [Anheden and Ahlroth, 1997, Ahlroth, 2000].

3 Simple IFGT

The simple-cycle IFGT, as shown in figure 1, is a modified gas turbine, where the internal gas burner is replaced by an external combustion chamber and a heat exchanger. The fuel fed to the cycle is not limited to gaseous fuels, but may be liquid or solid as well. In the present study, we establish a reference case where the fuel is wood chips or wood waste.

The configuration is in the ideal case comparable to a recuperated gas turbine having the same advantages as this cycle.

The main advantages are low optimal pressure ratio and a maximum efficiency equal to the Carnot efficiency for an ideal process (in the limit when the pressure ratio approaches unity).

Obviously, it also has the same disadvantages as a conventional gas turbine. The main problem is that, in real cases, the temperature of the exhaust gases is quite high leading to considerable exergy loss and, consequently, a low thermal efficiency.

The efficiency of the cycle is closely related to the maximum allowable gas temperature, i.e., the combustion temperature, which in turn determines the turbine inlet temperature, TIT .

The reference case for the optimization study is calculations on a "simple-cycle" IFGT running on

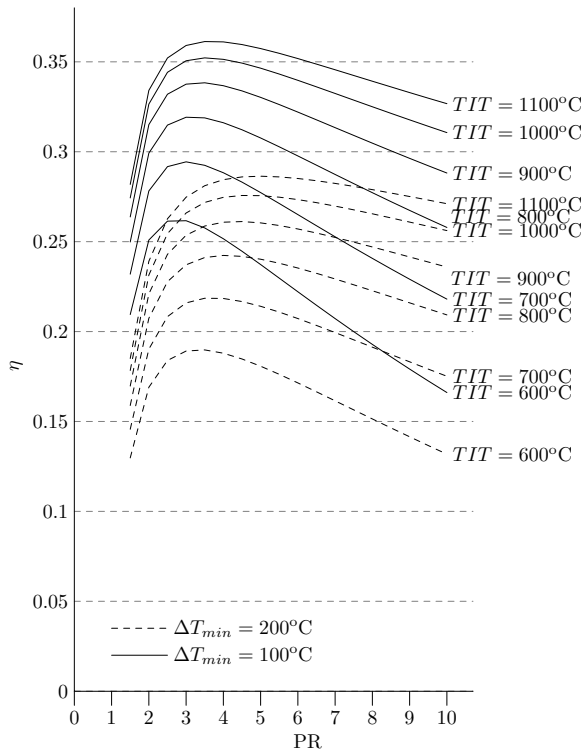

Figure 2: Efficiency of “Simple-Cycle” IFGT ($\eta_{is,c} = 0.9$, $\eta_{is,t} = 0.92$, $LHV_{dry} = 20.7$ MJ/kg)

biomass. The graphs in figure 2 show the correlation between efficiency of the cycle and the combustion temperature for temperature ratios, τ , between 2.9 and 4.6. The calculations have been made for a minimum temperature difference of 100°C and 200°C in the heat exchanger. It is clear that the efficiency of the simple cycle is determined uniquely by the combustion temperature and the heat exchanger effectiveness. It is also seen that the efficiencies obtained are very modest even for very high combustion temperatures. The efficiency reaches only 29% for a TIT of 1100°C.

From figure 3 it is seen that the flue gases to the stack are very hot. That may be utilized in the search for an better process layout.

Another important limitation of the cycle is the heat exchanger transferring heat from the combustion products to the compressed air. As the combustion products are led directly from the combustion chamber to the heat exchanger, they will contain corrosives such as chlorine, sulphur and fly ash. Different technologies may be applied to clean the gases, but the selection of a suitable material for the heat

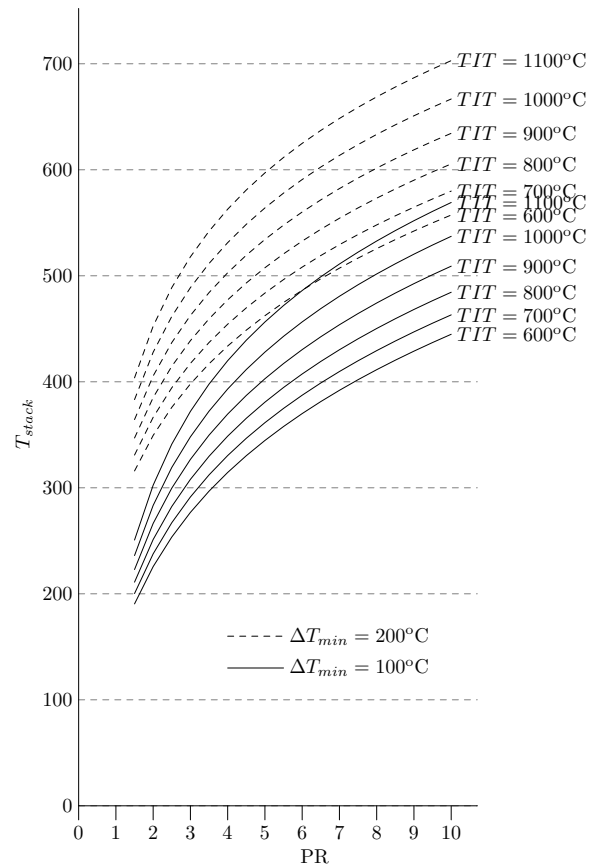

Figure 3: Stack temperature from “Simple-Cycle” IFGT

exchanger is a major challenge. In this respect, an important parameter is the material temperature. The lower this may be selected, the easier it will be to find a suitable material. Several studies have focused on the use of ceramic materials, thus allowing the use of higher temperatures [Pratt, 1999, Kumada, 1999, Luzzatto et al., 1997, Solomon et al., 1996]. However, if the gas turbine is going to be based on current technology, metallic materials will have to be used, thus limiting the maximum allowable temperature.

In the present study the maximum allowable temperature in the heat exchanger walls has been set to 700°C. In figure 2 it is seen that the simple cycle for this combustion temperature, which is attainable with commercially available technology, and a minimum temperature difference of 100°C, corresponding to an effectiveness of 0.8, has a maximum efficiency of 18.6% at a pressure ratio $PR = 3.0$. This low efficiency would make the IFGT uninteresting in most situations.

4 The “Wet IFGT” – IFGT Combined with Fuel Drying

In order to improve the cycle efficiency, utilization of the flue gas enthalpy is the natural source of improvement. The fuel may be dried in order to avoid the evaporation and heating of the moisture concurrent with the combustion. It should be realized that without drying, the steam will remain in the combustion products, resulting in a higher mass and enthalpy flow, but this enthalpy cannot be utilized as the combustion products does not enter the turbine.

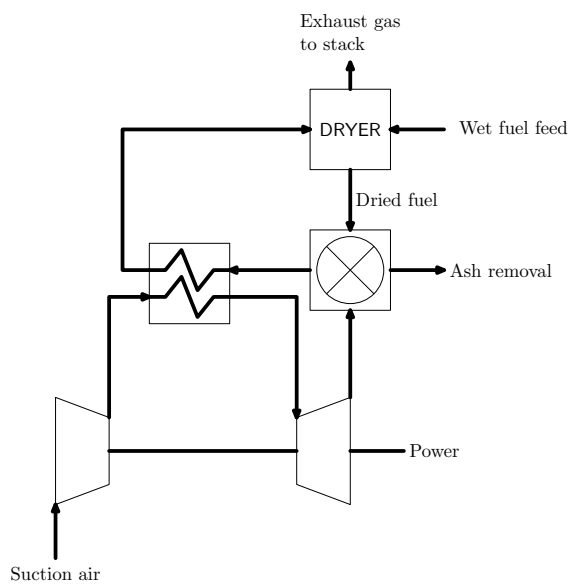

Figure 4: “Wet IFGT”

The flowsheet of a “Wet IFGT”, an IFGT with fuel drying is shown in figure 4. The wet fuel enters the dryer, where it is dried by the flue gas leaving the heat exchanger. The water in the fuel evaporates and is carried with the turbine exhaust to the stack. The dried fuel is led to the combustion chamber.

In the model it is assumed that the dried fuel and the flue gases, (including the evaporated water) leaving the dryer are at the same temperature. The heat exchanger effectiveness is 0.8, resulting in a turbine inlet temperature of 590°C with the combustion temperature of 700°C. Technically, biomass may be dried to around 10% moisture content.

The data that have been used for the wood chips are given in table 1, the cycle reaches an efficiency of 30.8% at a pressure ratio of 3.5. This may be compared

| | |
|---|-------------|
| Carbon | 59.00% |
| Hydrogen | 6.00% |
| Oxygen | 34.80% |
| Nitrogen | 0.08% |
| Sulphur | 0.04% |
| Ash | 0.08% |
| <hr/> | |
| Water content as received | 50.0% |
| Lower Heating Value (LHV_{dry}) | 20.74 MJ/kg |
| Lower Heating Value ($LHV_{received}$) | 11.02 MJ/kg |
| Higher Heating Value ($HHV_{received}$) | 9.15 MJ/kg |

Table 1: Data for Wood Chips (Percent by weight)

to the 24.6% obtained by the simple cycle. Thus, for wood chips the efficiency is raised by 24% by including the drying process. This result is very satisfactory, making the biomass-based IFGT competitive to other, more complex biomass cycles.

Furthermore, this result indicates that the use of the “wet IFGT” to even wetter fuels, such as sewer sludge, industrial waste and manure, all containing up to 85% water should be investigated. The results of a study of the IFGT working on fuels with a water content of up to 85% are shown in figure 5. Here it is seen that the efficiency of the cycle for very wet fuels is 80.0%. It is also seen that the efficiency based on higher heating value is constant and close to 25% for all water contents. This may be compared to the simple cycle running on wet fuel which has a net efficiency below 5% for the very wet fuels.

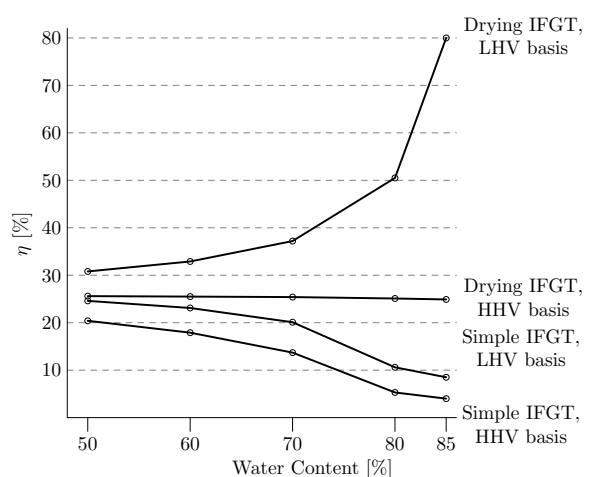

Figure 5: Net and Gross Efficiency of the Conventional and the “Wet IFGT” for Varying Fuel Water Content

However, as seen in figure 6, in this case, in which the combustion temperature is limited to 700°C, the stack temperature may be somewhat below 100°C, which may be inappropriate. Limiting the stack temperature to 100°C will require the moisture content of the fuel to be below 80%, at which the gross thermal efficiency is 50%. This still is a high efficiency for a power plant running on sewer sludge, and it may be raised by application of a higher combustion temperature. Higher combustion temperature will also raise the stack temperature for the wettest fuels. However, further studies show that a very high combustion temperature may be required. One way of keeping the stack temperature acceptably high, is to remove the water from the fuel to 75%–80% by mechanical means.

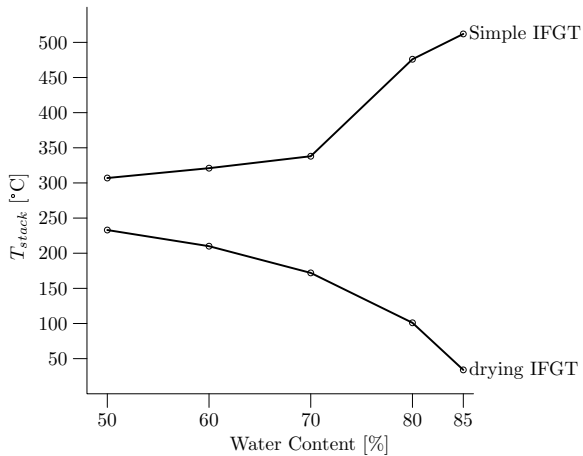

Figure 6: Stack Temperature of the Conventional and the “Wet IFGT” for Varying Moisture Content

5 Pressure Losses

Due to the low pressure ratio of the IFGT, the pressure losses in the process will have a considerable influence on the efficiency. This is illustrated in figure 7. The figure shows the efficiency of the cycle for both wood (50% water) and sludge/manure (80% water). For each of the two fuels the efficiency has been calculated for pressure losses assumed to be the same in each of the flow paths through passive components in the system (heat exchanger cold side, combustion chamber, heat exchanger warm side and dryer) and in the range of 0 to 0.4 bar in total.

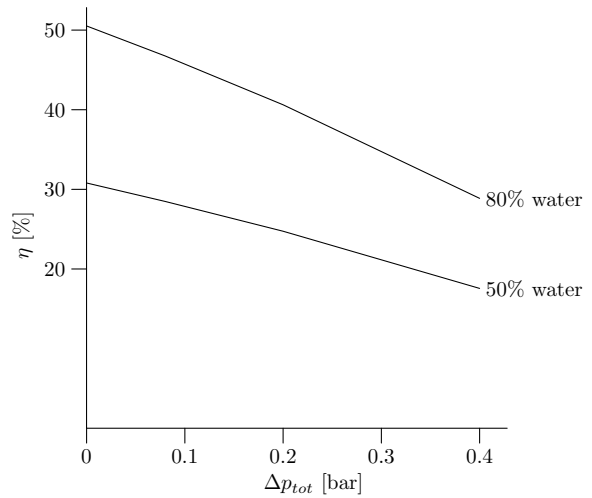

Figure 7: The Influence of Pressure Loss on Cycle Efficiency (LHV basis) for 50% and 80% Water Content in Fuel. (The pressure Loss, Δp_{tot} , is the total Pressure Loss in the cycle. The pressure losses in each of the Flows through Heat Exchanger Cold Side, Combustion, Heat Exchanger Hot Side and Dryer are equal.)

As expected pressure loss has a considerable influence on the efficiency of the cycle. This means that in an actual design of the components for the cycle an effort must be made to have as low pressure losses as possible.

6 Concerning Corrosives

The presence of corrosives in the flue gas is an important limitation to the cycle. It is therefore of importance to know the content of the aggressive gas compounds in the flue gas. Figure 8 shows the contents of the main corrosive compounds, chlorine and sulphur in the flue gases as a function of the excess-air ratio. The combustion, as carried out in the IFGT being considered, takes place at a high excess-air ratio. At the optimal pressure ratio of 3.5, the excess-air ratio, λ , is 7.0–7.2 for a water content of 50% to 80% in the fuel. In figure 8 it is seen that the amount of corrosives in the flue gas is very small, ≈ 25 ppm, for sulphur and almost vanishing for chlorine. These calculations are made with the assumption of wood (willow [Jenkins et al., 1998]) as a fuel and with the assumption of dry fuel. Sludges and waste streams may have a higher content of corrosives, but it is obvious that the

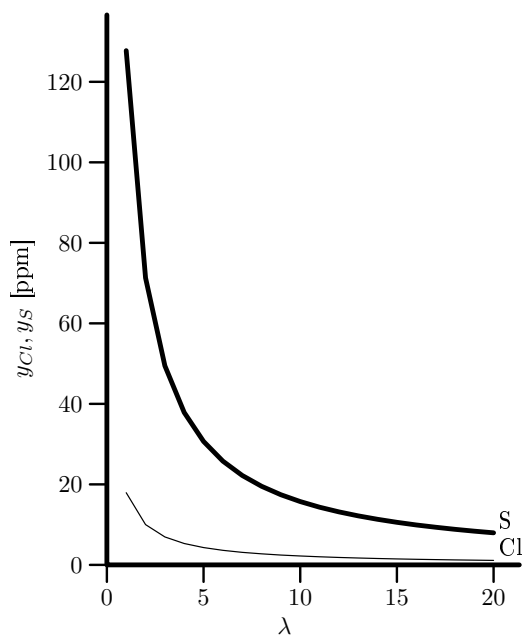

Figure 8: Contents of Sulphur and Chlorine in Flue Gas from Combustion of Dry Wood as a Function of Excess-air ratio

very high temperature of the combustion air coming from the expander allows the IFGT to be run at high excess-air ratio and thereby be less exposed to corrosives.

7 Perspectives and Further Work

This study has shown that the IFGT in which the exhaust gases are used for drying the fuel is very promising for application of wet biomass. The process may obtain well above 50% gross efficiency and has a constant net efficiency of 25% for the range of fuels considered in the present study. The stack temperature from the process is below 100°C for the highest moisture contents. For water contents less than 80%, no problems should be present, because the stack temperatures will be above 100°C. For higher water contents, mechanical water removal may be applied.

When the water content varies from 50% to 80% the stack temperature decreases from 250°C to 100°C. The enthalpy of this flow may be utilized for different purposes. These applications include

- production of process steam in industry

- heat for industrial processes, e.g., for drying of goods
- district or central heating

Many different fuels may be considered for the “wet IFGT”. Along with the more conventional biomass, such as wood chips and wood waste, many different industrial wastes and sludges can be found, e.g., in food industry. In agriculture, manure is an interesting fuel, which is now being utilized in biogas plants with a rather low thermal efficiency. (Partly, because the treated manure is used as fertilizer.)

It is also of interest to consider the integration of the IFGT and biomass gasification. By gasification it may be possible to separate the clean and the dirty parts of the fuel, such that part of the gasification gas (syn-gas) may be burned inside the gas turbine combustion chamber. A related idea is to boost the IFGT by addition of natural gas in the combustion chamber. Both applications will lead to higher thermal efficiency of the cycle.

The ongoing development of micro and mini gas turbines with recuperation will make it easier to apply the IFGT in industry and agriculture, because the fuel flow is relatively small. The main challenge in the development of a commercially useful IFGT is the development of the heat exchanger and its integration with the combustion chamber, and potentially the drying.

8 Conclusion

The “Wet IFGT” has opened for the potential of having IFGT with acceptably high efficiencies with current-technology heat exchangers. Alternatively, the development of heat exchangers that are able to withstand the temperatures and corrosiveness of the combustion products will lead to very high efficiency of electric power generation from very low-quality, cheap fuels.

9 Acknowledgements

Danish Energy Agency and Nordic Energy Research Programme for Process Integration are acknowledged for financial support of the work.

References

- [Ahlroth, 2000] Ahlroth, M. (2000). *Analysis of Closed Cycle Gas Turbines for Biomass Fuel*. PhD thesis, Sweden Royal Institute of Technology.
- [Anheden and Ahlroth, 1997] Anheden, M. and Ahlroth, M. (1997). System studies of a biomass fired CHP closed cycle gas turbine with CFB furnace. In Bejan, A., Feidt, M., Moran, M. J., and Tsatsaronis, G., editors, *Efficiency, Cost, Optimization, Simulation and Environmental Aspects of Energy Systems and Processes*, pages 651–659.
- [Beenackers, 1993] Beenackers, A. (1993). Biomass gasification: Implementation and research in Europe. *International Journal of Solar Energy*, 13:249–260.
- [Edelmann and Stuhlmüller, 1997] Edelmann, H. and Stuhlmüller, F. (1997). EFCC — ein zukünftiges konzept für kohle-kombi-kraftwerke. *VGB Kraftwerkstechnik*, 77(7):573–543.
- [Eidensten et al., 1996] Eidensten, L., Yan, J., and Svedberg, G. (1996). Biomass externally fired gas turbine cogeneration. *Journal of Engineering for Gas Turbines and Power*, 118:604–609.
- [Elmegaard, 1999] Elmegaard, B. (1999). *Simulation of Boiler Dynamics – Development, Evaluation and Application of General Energy system Simulation Tool*. PhD thesis, Technical University of Denmark.
- [Evans and Zaradic, 1996] Evans, R. and Zaradic, A. (1996). Optimization of a wood-waste-fuelled, indirectly fired gas turbine cogeneration plant. *Biore-source Technology*, 57:117–126.
- [Ferrato and Thonon, 1997] Ferrato, M. and Thonon, B. (1997). A compact ceramic plate-fin heat exchanger for gas turbine heat recovery. In *Conference in Snowbird, Utah, US, 1997*, pages –.
- [Jenkins et al., 1998] Jenkins, B., Baxter, L., Jr., T. M., and Miles, T. (1998). Combustion properties of biomass. *Fuel Processing Technology*, 54:17–46.
- [Kumada, 1999] Kumada, M. (1999). A study on the high performance ceramic heat exchanger for ultra high temperatures. *Heat Transfer Enhancement of Heat Exchangers*, pages 301–324.
- [LaHaye and Bary, 1994] LaHaye, P. G. and Bary, M. R. (1994). Externally fired combustion cycle (EFCC) a DOE Clean Coal V Project: Effective means of rejuvenation for older coal-fired stations. *ASME Paper*, (94-GT-483).
- [Luzzatto et al., 1997] Luzzatto, C., Morgana, A., Chaudourne, S., O’Doherty, T., and Sorbie, G. (1997). A new concept composite heat exchanger to be applied in high-temperature industrial processes. *Applied Thermal Engineering*, 17(8–10):789–797.
- [Oberberger, 1998] Oberberger, I. (1998). Decentralized biomass combustion: State of the art and future development. *Biomass and Bioenergy*, 14(1):33–56.
- [Pratt, 1999] Pratt, D. M. (1999). Emerging technologies for heat exchanger application. *Process Industry Division Newsletter*, pages 1–3.
- [Ruyck et al., 1994] Ruyck, J. D., Peeters, F., Bram, S., and Allard, G. (1994). An externally fired evaporative gas turbine cycle for small scale biomass ”CHP” production. In *IGTI-Vol 9, ASME COGEN-TURBO*, volume 9, pages 631–640. American Society of Mechanical Engineers.
- [Solomon et al., 1996] Solomon, P. R. et al. (1996). A coal-fired heat exchanger for an externally fired gas turbine. *Journal of Gas Turbines and Power*, 118(1):22–31.