



Consumer Unit for Low Energy District Heating Net

Paulsen, Otto; Fan, Jianhua; Furbo, Simon; Thorsen, Jan Eric

Published in:

Proceedings of The 11th International Symposium on District Heating and Cooling

Publication date:

2008

Document Version

Publisher's PDF, also known as Version of record

[Link back to DTU Orbit](#)

Citation (APA):

Paulsen, O., Fan, J., Furbo, S., & Thorsen, J. E. (2008). Consumer Unit for Low Energy District Heating Net. In Proceedings of The 11th International Symposium on District Heating and Cooling Reykjavik, ICELAND: Stofnun Árna Magnússonar á Íslandi.

DTU Library

Technical Information Center of Denmark

General rights

Copyright and moral rights for the publications made accessible in the public portal are retained by the authors and/or other copyright owners and it is a condition of accessing publications that users recognise and abide by the legal requirements associated with these rights.

- Users may download and print one copy of any publication from the public portal for the purpose of private study or research.
- You may not further distribute the material or use it for any profit-making activity or commercial gain
- You may freely distribute the URL identifying the publication in the public portal

If you believe that this document breaches copyright please contact us providing details, and we will remove access to the work immediately and investigate your claim.

Consumer Unit for Low Energy District Heating Net

Otto Paulsen¹

Jianhua Fan²

Simon Furbo³

Jan Eric Thorsen⁴

1 Ph.D., Danish Technological Institute, Centre for Ventilation and Energy Efficiency

2 Associate Professor, Ph.D., Technical University of Denmark

3 Associate Professor, Ph.D., Technical University of Denmark

4 Manager District Heating Application Centre, Danfoss A/S, DK-Nordborg

ABSTRACT

A low energy/ low temperature consumer installation is designed and analyzed. The consumer type is a low energy single family house 145 m² with annual energy consumption in the range of 7000 kWh, incl. domestic hot water in a 2800 degree day climate.

The network is an extreme low temperature system to reduce heat loss in the network.

The consumer's installation is a unit type with an accumulation tank for smoothing the heat load related to the domestic hot water. The building heat load is delivered by an under-floor heating system. The heavy under-floor heating system is assumed to smooth the room heat load on a daily basis, having a flow temperature control based on outdoor climate. The unit is designed for a near constant district heating water flow.

The paper describes two concepts. The analyses are based on TRNSYS (Klein et al., 2006) simulation, supplied with laboratory verification of the critical accumulator.

INTRODUCTION

As one part of the Danish governmentally founded project "Development and Demonstration of Low Energy District Heating for low energy Buildings", EFP2007, a new unit concept for a low energy district heating systems has been investigated and designed.

In Denmark new building regulations has been introduced which largely reduce the energy consumption. For single family houses this means, that the network heat loss may be a very significant part of the total energy consumptions. Nevertheless district heating has advantages compared to other sources, especially the possibility to use waste heat, combined heat and power, difficult fuels including flue gas cleaning etc.

Therefore it is interesting to investigate if a system minimizing the network heat loss and minimizing the water flows in the pipes is feasible. Such a low temperature system will also increase the potential for use of waste heat and improve electricity efficiency in the case of combined heat and power.

The project deals with the a system including network, building, consumer installation and heating system in the house for room heating and heating of domestic hot water. This paper deals with the consumer part of the system.

The design criteria allow for small network dimensions and a very low heat loss and are as follows:

- Flow temperature from net: 50 °C
- Return to net approx. 20 °C.

- Differential pressure 0.2 to 1 bar, in some cases higher.
- Design heat demand at -12 °C outdoor temperature approximately 2000 W
- Design flow temperature to the floor heating system : 28 °C, at - 12 °C outdoor temperature
- Design domestic hot water temperature: 40-45 °C
- Design cold water temperature 10 °C

Especially the pipes from the mains (placed in the street) to the house has small dimensions, typically 12 mm inside diameter or possibly even smaller. Some part of the building and network analyses is presented in P. K. Olsen(2008)

SYSTEM PRINCIPLES

Two different systems are included in the project, see figs. 1 and 2.

The *indirect system* fig.1 has a heat exchanger for the heating system, allowing for a high network pressure.

The *direct system* has a mixing valve and a shunt to control the flow temperature. This system has further two extra control valves to improve the cooling off.

Both systems have a buffer for the domestic hot water system.

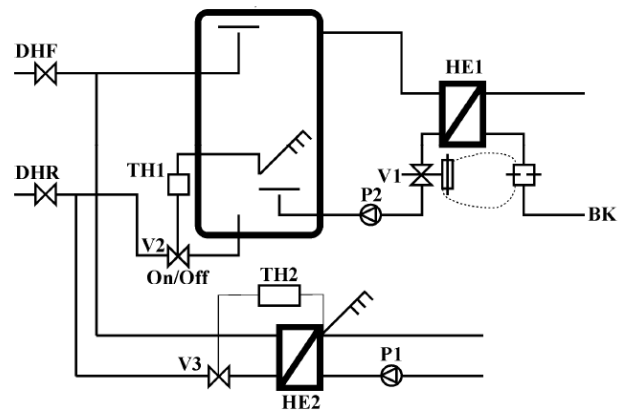

Fig.1. Sketch of the indirect system. A tap flow is detected by a flow switch to start the the pump P2. The flow from the accumulator to the heat exchanger is controlled by a flow compensated thermostatically operated control valve.

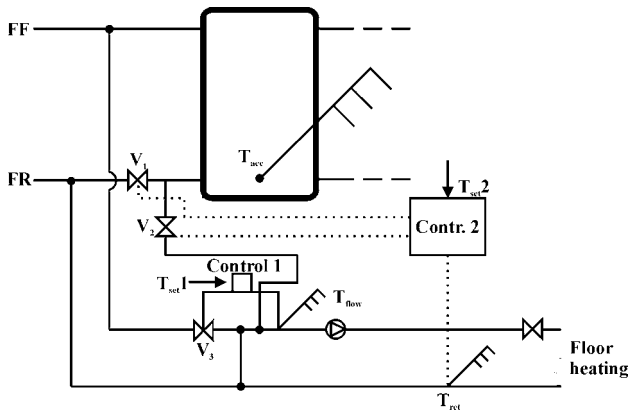

Fig. 2 Sketch of the direct system. The water heater is similar to the indirect system, fig 1. That valves V_1 and V_2 makes it possible to improve the overall cooling of the system. Domestic hot water system is produced in a similar way as in the indirect system, fig. 1.

DOMESTIC HOT WATER SYSTEM

The system includes a storage tank and a heat exchanger. Heat is stored with district heating fluid as the medium. Domestic hot water is produced by a heat exchanger, supplied from the tank. A flow switch detects a water flow and starts the pump.

The temperature supplied from the DH network is assumed always to have the same temperature (50 to 55 °C). The water temperature controller is flow compensated temperature type explained below.

The tank is sized for the expected maximum daily draw off. The primary water flow is then adjusted to be constant. In the normal case with a smaller daily tapping, the primary flow is controlled on/off by a simple thermostat and a constant flow valve or just a constant hydraulic resistance.

Using a higher primary flow reduces the necessary tank size and this may be analyzed including the properties of the network.

The tank is filled from the top and the exchanger return is connected to the tank bottom to secure stratification. The tank inlets are designed to avoid mixing.

Critical points in the system:

- Stratification of the tank
- Time delay in the taps caused by the pump starting
- Standby loss of the system

In this paper an overall analyses is given and the critical stratification is investigated.

HOT WATER FOR THE HYDRONIC UNDER-FLOOR HEATING

The indirect system is coupled in parallel to the domestic hot water system. The tap temperature is controlled by a (self acting or an electronic) control system.

The direct system has a possibility to be supplied from the return water from the storage tank. In the case when the return from the under-floor heating system has a lower temperature than the return from the tank this flow is directed to the floor heating system to achieve an extra cooling off. The mixing circuit is controlled by a two way control valve in a traditional way.

TRNSYS ANALYSIS OF THE SYSTEMS

The Trnsys models

Two Trnsys models have been developed for the indirect and the direct system respectively. Thermal stratification in the buffer tank is calculated with the Trnsys type 340, a well-recognized component within the research on thermal storage. In the component the tank is divided into a number of equal sized layers (approx. 150-198 nodes). In each layer the fluid is assumed to be fully mixed, therefore the layer can be represented by one node with a uniform temperature. There are one double port for the primary loop and one for the secondary loop respectively. The outlet ports are located at the very bottom or the very top of the tank. The inlet ports are deliberately positioned at different levels in order to simulate a certain mixing rate. A mixing rate of 10% is assumed for the cold water inlet at the bottom of the tank during discharge, while the mixing rate is assumed to be 5% for the hot water inlet at the top of the tank during charge. This means 10% of the tank volume from the bottom is fully mixed when the tank is discharged; 5% of the tank volume from the top is fully mixed when the tank is charged.

An effective thermal conductivity of the fluid is used in order to take into account the heat conduction in the tank wall. The effective thermal conductivity is determined by:

$$\lambda_{effective} = \lambda_{water} + \lambda_{steel} \cdot \frac{(d_y^2 - d_i^2)}{d_i^2}$$

where $\lambda_{effective}$ is the effective thermal conductivity of water in the tank; λ_{water} is the thermal conductivity of water; λ_{steel} is the thermal conductivity of tank material; d_y is the outer diameter of the tank; d_i is the inner diameter of the tank.

The heat loss coefficient from the tank is divided into three parts: the top, the bottom and the side of the tank. The coefficients depend on configuration of the tank like diameter and height of the tank and insulation of the tank. The coefficients are calculated by the equations given by Furbo (2005). As an example, the following table gives the heat loss coefficients of a 200 l tank with a diameter of 0.4 m and a height 1.59 m if the tank is insulated with 0.1 m mineral wool.

Table 1. Heat loss coefficients from a 200 liter tank

Part	top	bottom	side	Total
Unit	W/K	W/K	W/K	W/K
Heat loss coefficient	0.08	0.07	0.95	1.10

A fully charged tank is assumed at the start of the simulation. The initial temperature of the tank is 50°C. The time step of the TRNSYS calculation is 5 min.

DHW draw-off profile and space heating demand

A hot water draw-off profile similar to the Danish standard DS394 is used for a building without bath tub. The draw-off profile includes:

- (1) 42 liters × 4 showers. Each shower takes 300 s and there is a delay of 20 min between the showers.

(2) 15 liters × 2 kitchen washes for every 3 hours. Each wash takes 150 s and there is a delay of 20 min between washes.

(3) 10 liters × 4 hand washes for every 6 hours. Each wash takes 180 s and there is a delay of 20 min between washes.

For all the draw-offs, a tap temperature of 40°C and a cold water temperature of 10°C are used. The draw off profiles is enforced for 12 hours per day from 6:00 to 18:00. The daily hot water consumption is 368 l corresponding to an energy demand of 12.8 kWh. The volume flow rate and the tapped volume are shown in Fig. 3. It can be seen that the first hot water draw-off starts at 6:00AM. In approx. 65 min, there are 4 showers, 2 kitchen washes and 4 hand washes taken corresponding to 238 l of hot water draw-off.

The water volume at 50°C in the tank is shown in Fig. 3. Before 6:00 AM, the tank is fully charged. Sixty five minutes after the first draw-off start, the water volume in the tank at 50°C decreases from 200 l to 12 l. From 7:00 AM to 16:00 PM the tank is continuously charged and is discharged from time to time. At 16:00 PM the tank is emptied again. From 16:00 PM till 6:00 AM of the next day, the tank will be gradually charged and will be full before the start of the first draw-off of the next day.

Charging of the tank is control by temperature difference between a set temperature and the fluid temperature at the tank bottom. If the fluid temperature at the tank bottom is below the set temperature, charging will be activated. The charging is stopped if the tank bottom temperature reaches the set temperature.

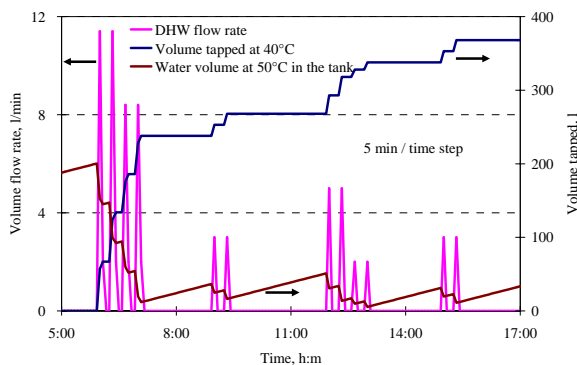

Fig. 3 Volume flow rate and tapped volume of the DHW draw-off profile.

A heat exchanger type Danfoss XB37H-60 is used for hot water preparation. The discharging is controlled by a on/off controller that activates discharging of the tank if there is a tapping. The discharging flow will be modulated based on the tapped temperature.

The daily space heating demand is calculated based on the reference building with a floor area of 145 m², resulting in a yearly space heating demand of 3026 kWh.

Influence of tank charging flow rate

For a given hot water draw-off profile, the required volume of the tank depends on the charging flow rate and performance of the tank. Investigations are carried out with the indirect system to find minimum required tank volume for different tank charging mass flow rates. The hot water draw-off profile in Fig. 3 is used. The set

temperature for control of the charging is 48°C. The required tank volumes are listed for different tank charging mass flow rates in the table 2.

It can be seen that if there is no heat storage tank the mass flow rate of district heating flow has to be approx. 680 kg/h in order to fulfill the demand of simultaneous tapping of shower and kitchen wash. If a tank volume of 60 liter is used as a heat buffer for DHW supply, the required mass flow rate can be decreased to 120 kg/h. If the tank size increases to 140 liter, the required mass flow rate is further decreased to approx. 58 kg/h. If a tank of 200 liter is used, the required mass flow rate can be furthestmost decreased to 14 kg/h which is the lowest flow rate when the charging of the tank is averaged out over the day.

Table 2 the minimum required tank volume for different charging flow rate (calculation of the first week of the year)

Tank charging flow rate	Minimum tank volume	Tank heat loss	Average tank return temperature
(kg/h)	(l)	kWh	°C
14	200	1.8	14.7
20	193	3.1	18.8
30	179	3.7	21.5
40	165	3.8	23.9
50	152	3.7	23.8
60	136	3.4	23.3
70	123	3.1	24.2
80	109	2.9	23.4
90	93	2.6	23.2
100	79	2.3	22.1
120	60	2.0	22.3
680*	0	-	12°C

Note: * the required mass flow rate is calculated based on a return fluid temperature of 12°C.

It can be seen from Fig. 4 that the average return water temperature from the tank to the district heating net is the lowest as 14.7°C for a tank volume of 200 liters. With a decrease of tank volume to 123 liters, the return water temperature increases to 24.2°C. The return water temperature is in the range of 22.1-24.2°C for a tank size between 60-165 liters.

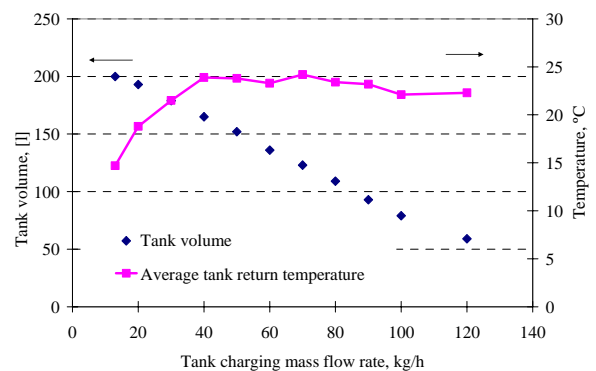

Fig. 4 Required tank volume and average tank return temperature as a function of tank charging mass flow rate.

200 l tank

A yearly calculation is carried out for the 200 l tank. The result is shown in table 3. If a tank of 200 l is used as the heat storage tank, the required mass flow rate of district

heating flow is 14 kg/h. The annual heat loss of the tank is 93 kWh. The average temperature of return water from the tank is 15.1°C. The average return temperature to the district heating net is 18.2°C. During the year the total volume through the tank is 116783 l while 16258 l of it is at a temperature higher than 25°C.

The temperature calculation during one day is shown in Fig. 5. From 0:00 to 6:00 the tank is slowly charged. The temperature of the return flow to the net is gradually increases from 14.6°C to 41.2°C. When the tapping starts, the tank is gradually filled with cold water, therefore the return temperature to the net decreases to 11.3°C for most of the day.

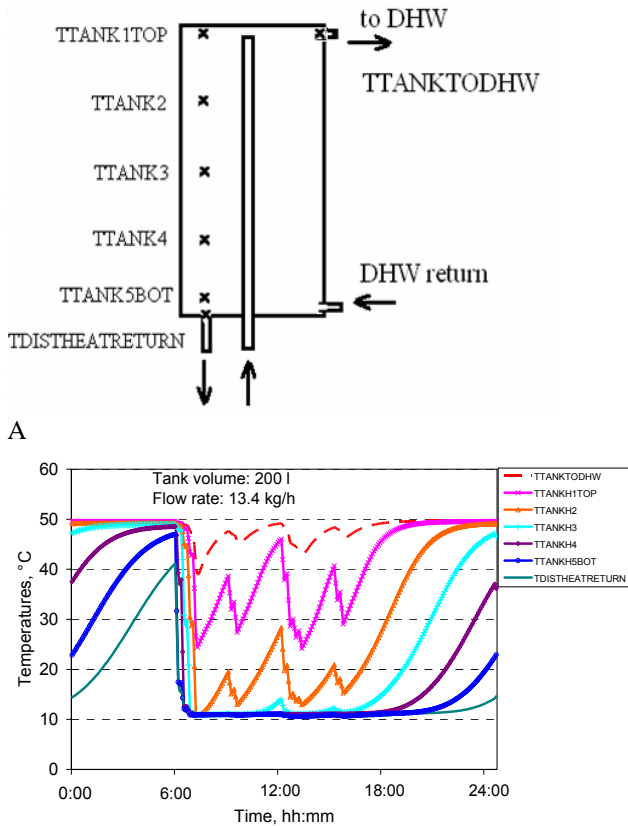

B
Fig. 5 (A) Positions of the different temperatures; (B) Calculation of Temperatures of one day.

The flow with a temperature higher than 25°C can be used for space heating thus the return flow is further cooled down before it goes back to the net. As shown in the table 3 more than half of the return water with a temperature higher than 25°C can be utilized for floor heating, resulting in an energy amount of 136 kWh transferred from the tank to the floor. The average return temperature to the district heating net is decreased by 1.2K.

Table 3 Comparison of yearly calculation of the indirect and the direct system

Variable	Unit	indirect	Direct
Tank charging flow rate	kg/h	14	14
Hot water consumption	m ³	134	134
Tank heat loss	kWh	93	93
Energy from district heating	kWh	7779	7779
Energy tapped for hot water consumption	kWh	4662	4662
Energy for space heating	kWh	3026	3026
Energy imbalance	kWh	0.29	0.13
Average return temperature of the system	°C	18.2	17.0
Average tank return temperature	°C	15.1	-
Total water volume through the tank	m ³	117	117
Water volume from the tank directed to the net with temperature T > 25°C	m ³	16	7
Energy transferred from the tank to the floor heating loop	kWh	-	136

The comparison between an indirect and a direct system is carried out for the 140 l and 60 l tank. The result is summarized in table 4.

The direct system can utilize the energy in the return water from the tank therefore decreases the average return temperature of the system to the district heating net. The annual energy transferred from the tank to the floor is 553 and 660 kWh for a system with 60 l and 140 l tank respectively. The average return temperature of the system is decreased by 2.5 and 2.7K for the direct system with a tank volume of 60 l and 140 l tank respectively.

Table 4 Summary of the yearly calculation with a hot water consumption of 368 l/day.

Tank size		liter	0	60	140	200
Required mass flow rate of the district heating flow		kg/h	680	120	58	14
Tank heat loss		kWh	-	104	181	93
Indirect system	Average return temperature of the separate system	°C	-	22.4	23.3	18.2
	Energy transferred from the tank to the floor heating loop	kWh	-	553	660	136
Direct system	Average return temperature of the combined system	°C	-	19.9	20.6	17.0

EXPERIMENTAL RESULTS

Experiments with a 200 l tank were carried out in order to validate the Trnsys models. The comparison of the temperatures during charging and discharging of the tank

are shown in Fig. 6-9. It can be seen from Fig. 6 that the calculation agrees with the measurement with an underestimated degree of thermal stratification. The reason for the disagreement is that it is not possible to

totally avoid numerical diffusion due to the limitation on the node number. Another reason of the disagreement is natural convection in the tank caused by heat loss from the wall. The water close to the tank wall will be cooled down creating a downward flow along the wall to the bottom of the tank. The warm water in inner part of the tank rises up, therefore improving thermal stratification in the tank. The flow due to natural convection is not considered in the model. The calculated energy content of the tank is similar to the measured value. It can be concluded that the Trnsys type is able to calculate thermal stratification in the tank although the degree of stratification is a bit underestimated. This is to be considered on the safe side.

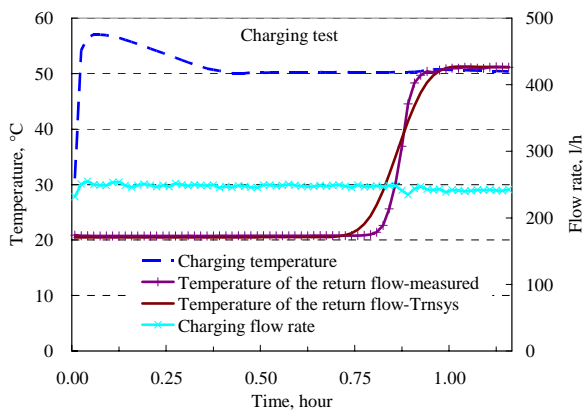

Fig. 6 Supply and return temperature of the charging flow in the charging test.

Fig. 7 shows temperatures at different height of the tank. The temperature from calculation is the average water temperature of the layer. The measured temperature is the surface temperature of the tank. The distance between the sensors is 0.2 m. It can be seen that the calculation agrees well with the measurement.

The discharging test is carried out with a uniform temperature of 50°C as a start. The dhw is provided by heating cold water from 10 °C to 40°C by the district heating fluid from the tank through a heat exchanger. A hot water of 38 l is tapped in one draw-off. When the tank is discharged, the cold water enters the bottom of the tank and the hot water leaves the tank from the top. The inputs to the model are the temperature of the flow from the heat exchanger and the volume flow rate. When there is no hot water draw-off, the tank is charged with a constant flow rate of 15 l/h. The temperature of the charging flow is 50-51°C. The inputs to the model are the temperature of the charging flow and the flow rate of the charging flow. The tank can either be charged or discharged. Fig. 8 shows flow rate during discharging by curve with + and flow rate during charging by curve with x. When the tank is discharged, the cold water inlet temperature at the tank bottom is given as input. The hot water supply at the tank top is validated against measurement. The calculated temperature is 0-1K lower than the measurement for the first five and the 7th draw-offs. For the 6th and the 8th draw-off, the temperature is underestimated by 0-2.4K. When the tank is charged, the temperature at the top of the tank is used as input. The calculated temperature at the bottom of the tank is

compared to the measurement. It is shown that the difference between the calculation and the measurement is within 2.5K.

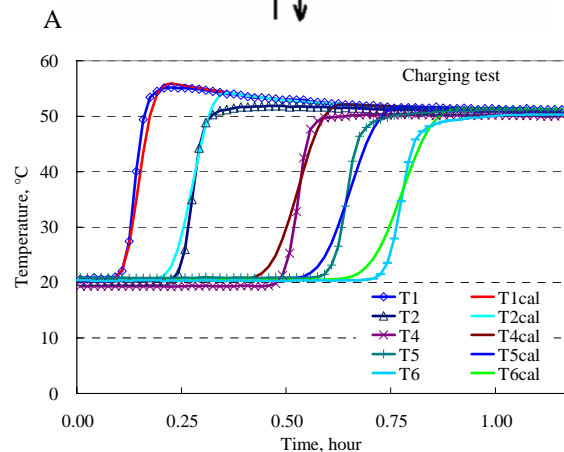
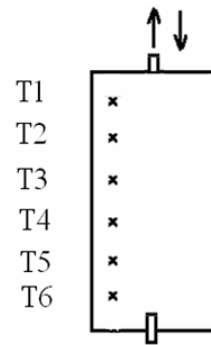

Fig. 7 (A) Positions of the temperature sensors; (B) Calculated fluid temperature and measured tank surface temperature in different height of the tank in the charging test.

Fig. 9 shows temperatures at different height of the tank. The temperature from calculation is the average water temperature in the layer. The measured temperature is the surface temperature of the tank. The positions of the sensors is shown in Fig. 7 (A). It can be seen that the calculation is able to predict the temperatures in different tank levels with satisfactory accuracy.

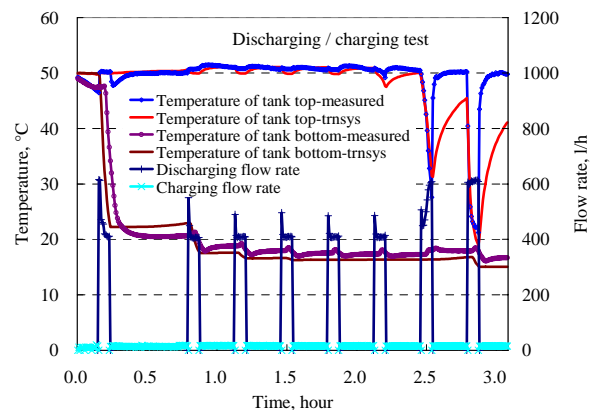

Fig. 8 Temperatures and flow rates during discharging/charging test.

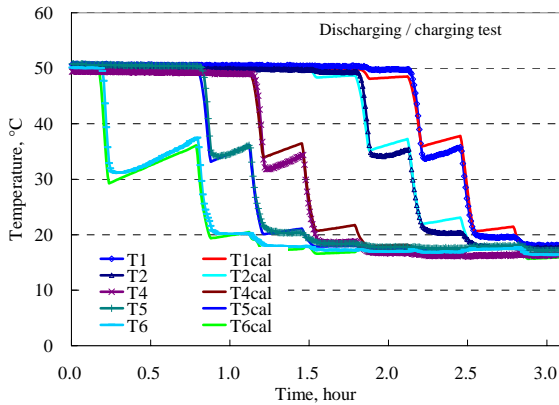

Fig. 9 Calculated fluid temperature and measured tank surface temperature in different height of the tank in the discharging/charging test.

CONCEPTUAL LAY OUT OF THE UNIT

An important practical issue when installing a tank unit is the dimension and weight. The dimension is as maximum limited to the size of the doors and height of the ceiling. In Denmark the standard element with of 60cm is respected, resulting in a maximum with of 57 cm for the unit, giving the possibility for building it into standard elements, e.g. the closet. The height must be limited to 215 cm if the unit is pre assembled. For the designed prototypes the height is 215cm for 200 liter tank, and 150cm for 100 liter tank.

The conceptual layout of the unit is shown in fig. 10: The consumer unit is split into three main sections, where the top section is the tank itself, the middle section consists of the "block" of components, e.g. pipes, heat exchanger, control valves, wiring and controls, and the third and lowest part consist of the connections and the manifold for under floor heating.

By this split, the consumer unit can be installed as pre assembled unit or installed in sections to ease the process, especially weight is an issue for the handling. In the last case the tank itself has to be installed first, the middle parts with pipes etc. at second, and finally the cover with insulation. Alternatively the tank could be pre insulated by PUR foam, and the removable insulation covers then the lower sections of the unit.

Control components and Performance

The most critical components regarding performance for the unit is the tank, as described above, the controller for dhw and the heat exchanger.

The heat exchanger

Due to the low operating temperature differences, with a dT_{lm} in the range 6 to 8°C, a high efficient heat exchanger is to be applied. In common dhw applications the dT_{lm} is in the range 12 to 14°C. This means the normally used heat exchanger plate area increases significantly. In this case it increases approximately a factor 4. The plate corrugation must result in a high

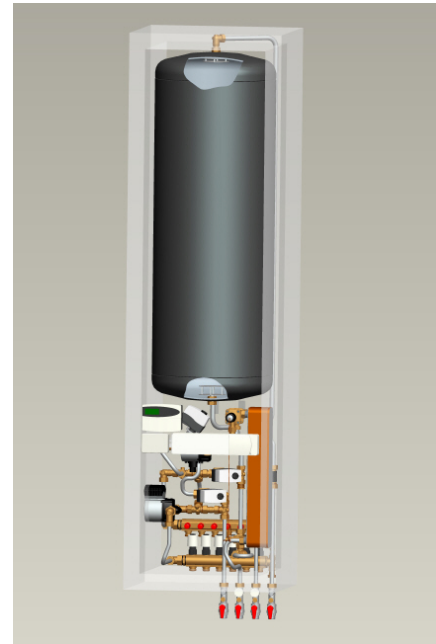

Fig. 10 3D CAD model of consumer unit with 200 liter storage tank.

turbulence level for assuring a high heat transfer coefficient. For this purpose a new development heat exchanger type, the Danfoss XB37-H, will be used. This heat exchanger has a high heat transfer coefficient combined with a relative low pressure drop, and at the same time stronger design, utilized in lower material consumption.

The controller for dhw

The controller used for dhw heat exchanger control is the recently introduced Danfoss IHTP controller, which consists of a integrated flow compensated thermostatically operated control valve, fig. 11.

Due to the low dT_{lm} , the controller has to maintain very accurate control. Assuming if the primary flow is a bit too high, the primary return temperature will increase to a unacceptable high level. The heat exchanger basically short cuts. E.g. one degree higher dhw temperature, from 45°C level results in 1 to 2 K degree higher primary return temperature. Assuming the primary flow is a bit too low, the consequence is a lower dhw temperature, which already is set relatively low, and by this comfort is compromised.

The main factors for obtaining high level of control performance are:

The controller sensor temperature versus position, say thermostatic gain at specific position, is adapted very accurate to the stability requirements for the whole operating range. (from min. htw load to max. htw load).

The integrated flow compensation eliminates the "P" deviation from the thermostatic control valve.

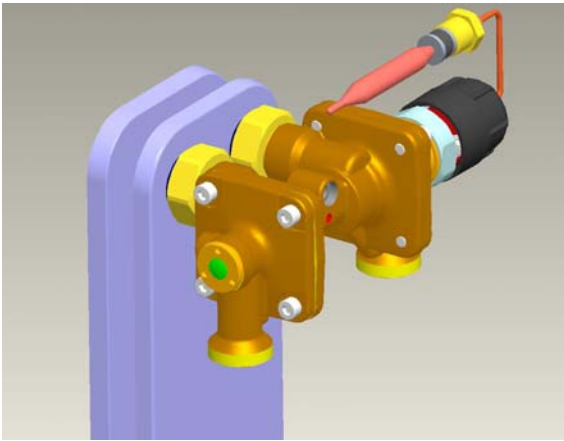

Fig.11 3D CAD model of Danfoss IHPT flow compensated thermostatically operated control valve, mounted directly on the heat exchanger.

The ratio between friction forces and actuation forces is low. A differential pressure controller is integrated for eliminating

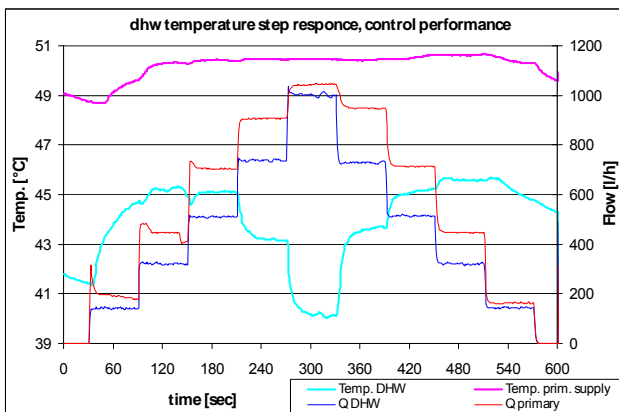

Fig.12. Measured step response dhw temperature profile for Danfoss IHPT controller.

the decrease in control performance due to variations in flow depended pump head applied on the valve primary side.

An example of control performance for Danfoss IHPT control valve:

As it can be seen on figure 12, the dhw tapping temperature is very constant for the stationary values of the three first tapping steps, up to 500 l/h. For these steps the temperature over and undershoots are almost not visible, anyhow excluding the initial step, where settling time is a bit longer due capacity effects from the heat exchanger outlet to the unit outlet. At higher tapping steps, 750 and 1000 l/h, the capacity limits of dhw are more evident, even dhw temperature drops first become below specifications for the 1000 l/h dhw tapping step. Looking at the primary flow, a very fast reaction to the secondary tapping changes can be observed.

The thermostat also provides fast "heat up" of the dhw system after an idle period where the piping and heat exchanger is partly cooled of, due to the full opening of the valve until desired dhw temperature is reached. This

can not be obtained with a controller working solely on the flow proportional principle, where delays for the lower tapping steps are most critical.

Insulation:

Due to the low energy consumption of the building itself, the heat loss from the unit has to be low as well. The unit is designed with 60mm PUR foam or mineral wool insulation, resulting in a heat loss of approx. 60 W, resulting in a yearly loss of 530 kWh, or approx. 17% of the yearly demand. It's assumed that half of the yearly heat loss can be utilized as heating.

CONCLUSION AND RECOMMENDATIONS

As a part of a governmental supported research project within District Heating two designs of consumers units are described and evaluated. The criteria include very low supply temperature and very small water flows.

The designs are investigated using the Trnsys software. The analyses show that it is in fact possible to realize the design criteria. One critical point is the temperature stratification in the accumulator. This has been verified experimentally and is shown that the stratification was better in the real situation than expected from the calculations. This may be caused by numerical diffusion in the equation solver or by the assumptions concerning mixing in some parts of the tank.

It is possible to base a district heating system for single family houses on flow temperature just a little higher than 50 C and obtain a return temperature below 20 C as an average.

Referring to Olsen(2008) it is possible to achieve a heat loss from the underground network as low as 15 % of the heat delivery at heat production plant. The 15 % is often considered as a key figure among district heating people.

There still remain some critical points concerning the unit: the heat loss from the unit and the losses related to the starting phase when tapping hot domestic water. Those problems will be further investigated and possible solutions are expected to be found.

ACKNOWLEDGEMENT

The research project is cooperation between the following:

Danish Technical University
Danish Technological Institute
COWI
Danfoss
Logstor
The Danish Energy Service

The authors wish to thank the member of the working group for many fruitful discussions

ABBREVIATIONS:

dhw:: domestic hot water

dT_{lm}: logarithmic mean temperature difference

REFERENCES

Olsen, P. K., Svendsen, S., Bøhm, B., Christiansen, C., Lambertsen, H. H., Larsen, C. T., Worm, J. (2008): A New Low Temperature District Heating System for Low Energy Buildings. The 11th International Symposium on District Heating and Cooling. August 31 to September 2, 2008, Reykjavik, ICELAND

Furbo, S. (2005) Heat storage for solar heating systems, Educational note, BYG.DTU U-071, ISSN 1396-4046, 2005, pp 17-18.

Klein, S.A. et al., (2006) TRNSYS manual version 16.1, Solar Energy Laboratory, University of Wisconsin.

Thorsen, J.E., Boysen, H. (2004): "Control Concepts for DH Compact Stations Investigated by Simulations". 9th *International Symposium on District Heating and Cooling, Finland.*

Thorsen, J.E. (2002): "Dynamic Simulations of DH House Stations". 7. *Dresdener Fernwärme-Kolloquium, Germany*

Benonysson, A., Boysen, H. (1995): "Optimum control of heat exchangers". 5th *International symposium on automation of district heating systems, Finland.*