

Technical University of Denmark



Mapping of grid faults and grid codes

Iov, F.; Hansen, Anca Daniela; Sørensen, Poul Ejnar; Cutululis, Nicolaos Antonio

Publication date:
2007

Document Version
Publisher's PDF, also known as Version of record

[Link back to DTU Orbit](#)

Citation (APA):

Iov, F., Hansen, A. D., Sørensen, P. E., & Cutululis, N. A. (2007). Mapping of grid faults and grid codes. Risø National Laboratory. (Denmark. Forskningscenter Risøe. Risøe-R; No. 1617(EN)).

DTU Library

Technical Information Center of Denmark

General rights

Copyright and moral rights for the publications made accessible in the public portal are retained by the authors and/or other copyright owners and it is a condition of accessing publications that users recognise and abide by the legal requirements associated with these rights.

- Users may download and print one copy of any publication from the public portal for the purpose of private study or research.
- You may not further distribute the material or use it for any profit-making activity or commercial gain
- You may freely distribute the URL identifying the publication in the public portal

If you believe that this document breaches copyright please contact us providing details, and we will remove access to the work immediately and investigate your claim.



RISØ

Mapping of grid faults and grid codes

Florin Iov, Anca Daniela Hansen, Poul Sørensen,
Nicolaos Antonio Cutululis

Risø-R-1617(EN)

Risø National Laboratory
Technical University of Denmark
Roskilde, Denmark
July 2007



Author: Florin Iov*, Anca Daniela Hansen**, Poul Sørensen**, Nicolaos Antonio Cutululis**

Title: Mapping of grid faults and grid codes

Department:

*Aalborg University, Institute of Energy Technology

**Risø National Laboratory, Wind Energy Department, VES

Abstract (max. 2000 char.):

The present report is a part of the research project "Grid fault and design-basis for wind turbine" supported by Energinet.dk through the grant PSO F&U 6319.

The objective of this project is to investigate into the consequences of the new grid connection requirements for the fatigue and extreme loads of wind turbines. The goal is also to clarify and define possible new directions in the certification process of power plant wind turbines, namely wind turbines, which participate actively in the stabilisation of power systems. Practical experience shows that there is a need for such investigations. The grid connection requirements for wind turbines have increased significantly during the last 5-10 years. Especially the requirements for wind turbines to stay connected to the grid during and after voltage sags, imply potential challenges in the design of wind turbines. These requirements pose challenges for the design of both the electrical system and the mechanical structure of wind turbines. An overview over the frequency of grid faults and the grid connection requirements in different relevant countries is done in this report. The most relevant study cases for the quantification of the loads' impact on the wind turbines' lifetime are defined.

The goal of this report is to present a mapping of different grid fault types and their frequency in different countries. The report provides also a detailed overview of the Low Voltage Ride-Through Capabilities for wind turbines in different relevant countries. The most relevant study cases for the quantification of the loads' impact on the wind turbines' lifetime are defined

Risø-R-1617(EN)
July 2007

ISSN 0106-2840
ISBN 978-87-550-3622-2

Contract no.:
PSO F&U 6319

Group's own reg. no.:
(Føniks PSP-element)

Sponsorship:

Cover :

Pages:
Tables:
References:

Information Service Department
Risø National Laboratory
Technical University of Denmark
P.O.Box 49
DK-4000 Roskilde
Denmark
Telephone +45 46774004
bibl@risoe.dk
Fax +45 46774013
www.risoe.dk

Contents

Contents	3
Preface	5
Acknowledgements	5
1 Introduction	6
2 Events in Electrical Network	8
2.1 Definitions and Classifications	8
2.2 Short interruptions	9
2.2.1 Terms and definitions	9
2.2.2 Origin	9
2.3 Voltage sags	10
2.3.1 Terms and definitions	10
2.3.2 Origin	10
2.4 Events survey in different countries	11
2.4.1 US and Canada	11
2.4.2 France	12
2.4.3 Nordel	13
2.4.4 Summary	15
3 Requirements for LVRT Capability in National Grid Codes	16
3.1 Denmark	16
3.1.1 Distribution System	16
3.1.2 Transmission System	17
3.1.2.1 Stability analysis during symmetric three-phase faults	18
3.1.2.2 Stability analysis during asymmetric faults and unsuccessful reclosure	20
3.2 Ireland	20
3.2.1 Distribution system	20
3.2.2 Transmission System	21
3.3 Germany	21
3.4 Great Britain	23
3.5 Spain	24
3.6 Italy	25
3.7 USA	25
3.8 Canada	26
3.8.1 Hydro-Quebec	26
3.8.2 AESO-Alberta	27
3.8.3 IESO-Ontario	27
3.8.4 Conclusions	28
3.9 Summary	28
4 Fault analysis	30
4.1 Simulation Model	30
4.2 Study cases	32
4.2.1 Three-phase short-circuit at 1 pu driven torque	33
4.2.2 Two-phase short-circuit with ground at 1 pu driven torque	34
4.2.3 Two-phase short-circuit without ground at 1 pu driven torque	35

4.2.4 Single phase short-circuit at 1 pu driven torque	36
4.2.5 Three-phase short-circuit at 0.25 pu driven torque	37
4.3 Conclusions	38
5 General Conclusions	38
References	39

Preface

The present report is a part of the research project “Grid fault and design-basis for wind turbine” supported by Energinet.dk through the grant PSO F&U 6319. The project is carried out in cooperation by RISØ National Laboratory and Institute of Energy Technology, Aalborg University.

Acknowledgements

The first author would also like to acknowledge the support from the European Commission through the contract no. 019794 (FP6-SES6), acronym UNIFLEX-PM.

1 Introduction

The World Energy Council predicts that by 2050, the global energy mix will be made up of different energy sources in which renewables will have an important share. On the same time the European Union has a target of 22% electricity generation from renewables by 2010 and recognizes that wind power will be the main contributor to meeting this goal [1]. A study from European Wind Energy Association [2] estimates that wind is capable of delivering 12% from the electricity consumption by 2020 and in excess of 20% by 2030. According with International Energy Agency in the last decade wind power had one of the highest average annual growth rates among renewable sources [3]. On the same time the wind turbines become in the last decade bigger and bigger and currently single units up to 5 MW are commercially available. Europe seems to lead at this moment the penetration of the wind power into the electrical network, Denmark and the northern Germany having the highest level of penetration. In 2006 more than 20% from the total electricity consumption in Denmark was provided by the wind power. Spain and Ireland as well as Great Britain will install more wind power in the near future. The future development of wind power is also expected in Canada, Australia and Japan.

Modern MW wind turbines currently replace a large number of small wind turbines and there is a significant attention to offshore wind parks/farms, mainly because of higher average wind speed and no space limitations. Large wind farms like Horns Rev (160 MW) or Nysted (170 MW) in Denmark are in operation and more large wind farms are in construction or in the planning stage all over Europe.

However, in order to achieve objectives as continuity and security of the supply a high level of wind power into electrical network poses new challenges as well as new approaches in operation of the power system. Therefore some countries have issued dedicated grid codes for connecting the wind turbines/farms to the electrical network addressed to transmission and/or distributed system. In most of the cases, e.g. Denmark, Germany, Ireland these requirements have focus on power controllability, power quality, fault ride-through capability. Moreover, some grid codes require grid support during network disturbances e.g. Germany and Spain. Denmark has the most demanding requirements regarding the controllability of the produced power. Wind farms connected at the transmission level shall act as a conventional power plant providing a wide range of controlling the output power based on Transmission Network Operators demands and also participation in primary and secondary control. The power quality requirements are very demanding in respect with flicker emission as well as the harmonic compatibility levels for voltages especially at Distribution System level comparing with relevant standards. All existing grid codes require fault ride-through capabilities for wind turbines. Voltage profiles are given specifying the depth of the voltage dip and the clearance time as well. However, in some of the grid codes the calculation of the voltage during all types of unsymmetrical faults is very well defined e.g. Ireland, while others do not define clearly this procedure.

Many references e.g. [2], [27] and [33] consider that the present grid codes often contain costly and demanding requirements e.g. fault ride-through capability and primary control which are not reflecting the real penetration of the wind power in a given area.

Moreover, according to [2] “grid codes and other technical requirements should reflect the true technical needs for system operation and should be developed in cooperation between Transmission System Operators, the wind energy sector and government bodies.

The present report will give first an overview regarding the definitions and classification of the events in the electrical network with a focus on voltage sags. The origins and the influence of the transformer connection are also treated. Then, some statistics in different countries e.g. US, France and Nordic countries regarding the frequency of the faults in terms of amplitude, duration and fault types are given.

Next, an overview of the existing grid codes regarding the Low Voltage Ride-Through capability of the wind turbines connected at distribution and/or transmission networks in different countries is presented.

In order to assess the impact of different fault types as well as the grid conditions on the drive train of a directly grid connected based induction generator wind turbine some simulation studies are carried out.

Finally some overall conclusions are drawn.

2 Events in Electrical Network

2.1 Definitions and Classifications

Various events can occur in the electrical networks and most of them are related with the network voltage. These voltage events usually are characterized by a change in the magnitude of the voltage and they can have different time durations from milliseconds up to hours [4]. Based on these two main characteristics namely magnitude and duration the voltage events are classified by standards in different ways [4].

The standard EN 50160 [5] is focused on characterisation of voltage in low and medium voltage networks while IEEE Std. 1159 states that “there is no implied limitation on the voltage rating of the power system being monitored” [6]. The momentary voltage disturbances are classified in IEEE Std. 1250 [7] for duration up to a few seconds.

Moreover, the terminology used in these standards is very different. For example the same event in EN 50160 is called “voltage dip” while in IEEE Std 1159 it is referred as “voltage sag”. However, the magnitude of this event is defined different in these standards.

In order to illustrate these differences the definitions of voltage magnitude events from both standards are presented in Fig. 1.

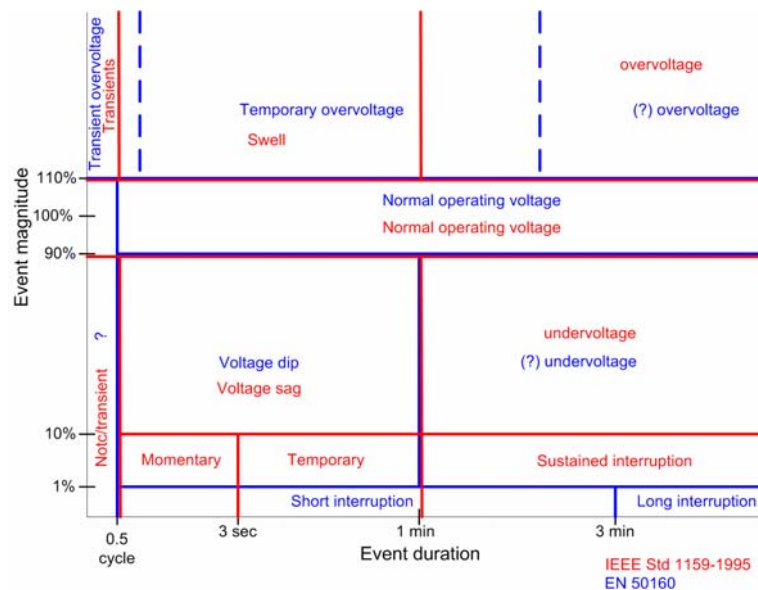

Fig. 1. Definition of voltage magnitude events based on standards.
(source [4], [5] and [6])

This method of classification of events in the electrical network based on magnitude and duration has advantages and drawbacks. In reference [4] it is stated that the following items are of concern when using this method:

- The RMS voltage during the event is not always constant and therefore this method might lead to ambiguities in defining the magnitude and duration of the event.
- Fast events with duration of less than one cycle cannot be defined very well because the RMS voltage cannot be calculated precisely.

- Repetitive events can give erroneous results. In this case the numbers of events can either be underestimated or overestimated.

In this report the focus is on network events characterized by a voltage drop down to 0.1 pu or less and durations up to 1 second. Based on [4] two types of events are characterized by this magnitude and duration namely short interruptions and voltage sags. These events can mainly be related with short-circuits in the electrical networks.

2.2 Short interruptions

2.2.1 Terms and definitions

The definitions for this class of events as defined in the standards [5], [6] and [7] are summarized in Table 1.

Table 1. Definitions for short interruption in various standards

Standard	Definition	Magnitude	Duration	Applicability
EN 50160	Short interruption	< 1%	Up to 3 min	LV and MV (up to 35 kV)
IEEE Std 1159-1995	Momentary interruption	< 10%	0.5 cycles to 3 sec	LV, MV, HV
IEEE Std 1250-1995	Instantaneous interruption	Complete loss of voltage	0.5 cycles to 0.5 sec	LV, MV, HV
	Momentary interruption		0.5 sec to 2 sec	LV, MV, HV

As it can be observed in Table 1 only IEEE Std 1159-1995 covers the whole range of voltages while EN 50160 is limited to 30 kV networks.

2.2.2 Origin

The origins of the voltage interruptions in general are “faults which subsequently trigger protection measure” [4]. Among other causes the following shall be mentioned [4]:

- Protection operation when there is no fault;
- Broken conductors not triggering protective measure
- Operator intervention

“When the supply is restored automatically, the result event is called a short interruption” [4]. Based on the network layout between the location of the fault and the point where the voltage is measured and the protection schemes used, the event is “seen” in a different way as shown in Fig. 2.

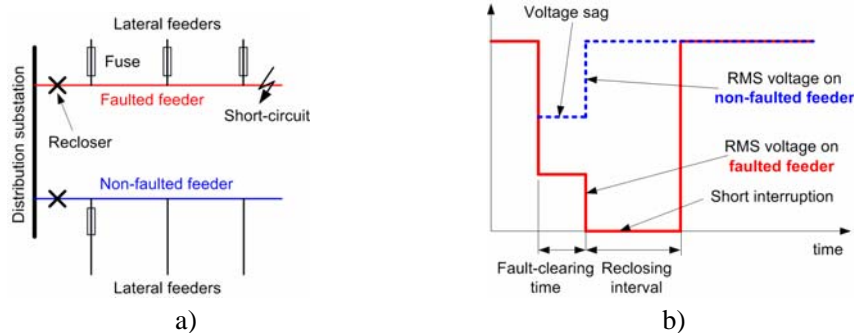

Fig. 2. Fault in a distribution network: a) network layout and b) RMS voltages on feeders.

The voltage on the faulted feeder will drop to zero while the non-faulted feeder will “see” a voltage sag.

2.3 Voltage sags

2.3.1 Terms and definitions

A summary of different terms and definitions for voltage sags as given in standards is presented in Table 2.

Table 2. Definitions of voltage sags in various standards.

Standard	Magnitude	Duration	Applicability
EN 50160	1% - 90%	0.5 cycles to 1 min	LV and MV (up to 35 kV)
IEEE Std 1159-1995	10% - 90%	0.5 cycles to 1 min	LV, MV, HV
IEEE Std 1250-1995	Reduction of voltage	0.5 cycles to few sec	LV, MV, HV

2.3.2 Origin

According to [4] the voltage sags “are short duration reductions in RMS voltage, caused by short circuits, overloads and starting of large motors. Since voltage sags are caused by short-circuit faults located at hundreds of kilometres away in the transmission system these events are a more “global” problems than an interruption [4].

The magnitude of the voltage sags are determined by the following factors [4]:

- Distance to fault
- Cross section of the lines and cables
- Connection type of transformers between the location of fault and the recording point
- Type of the network (radial or loops)
- Short-circuit impedance of the network, etc

An overview regarding the influence of transformer winding connections on the propagation of voltage sags is given in [8].

For example different short-circuit types on the high-voltage windings of an Dy1 or Dy11 transformer, which is very common in wind turbine systems, leads to different voltage sags on the low voltage side of it as shown in Fig. 3. However, when several cascaded transformers are present between the fault location and the “reading” point of voltage, the voltage sag will be determined by the connection types of all these transformers.

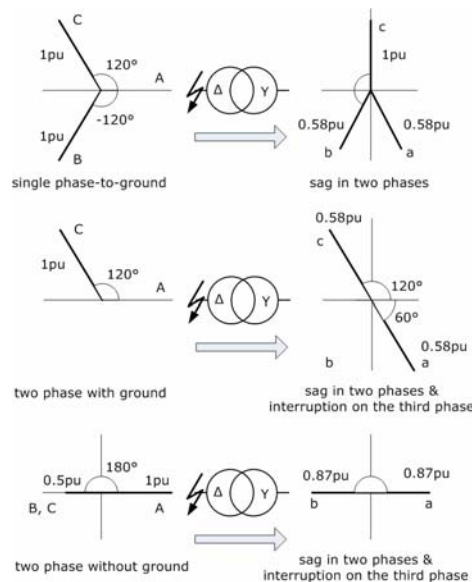

Fig. 3. Propagation of voltage sags caused by asymmetrical faults on a Dy1 transformer.

2.4 Events survey in different countries

2.4.1 US and Canada

A very comprehensive investigation regarding power quality for US and Canada is presented in [9] and [10]. This study is based on three surveys conducted by National Power Laboratory (NPL), the Canadian Electrical Association (CEA) and the Electric Power Research Institute (EPRI).

The CEA survey of power quality has run for three years since 1991 and 22 utility companies have participated. The main focus was on residential, commercial and industrial customer sites which have been monitored at their low voltage connection.

The NPL survey had also focused on low voltage networks and it has been running for a five years beginning with 1990. The main goal was to monitor single-phase normal-mode electrical disturbances.

The EPRI survey run between June 1993 and September 1995 aimed to “perform the most thorough study to describe power quality levels on primary distribution system in the US” [10]. During this survey the medium voltage networks ranged between 4.16 kV and 34.5 kV and lengths from 1 to 80 km were monitored. “One third of the monitors were located at substations just down line from the feeder circuit breaker, while the remaining monitors were randomly placed along three-phase sections of the feeder primary” [10]. The data presented in [9] and [10] are also used in [4].

Since in the present report the focus is on the network events at the medium and high voltage levels, only some results from the EPRI survey will be highlighted.

The EPRI low RMS event data for substation monitors with a 5 min filter are shown in Fig. 4 while the survey for feeder monitors is given in Fig. 5. Both data are filtered with a 5-min filter. The reason of using this filter is that “from a critical process perspective, it is likely that once a process drops out, other events within a 5 min period are probably not going to impact that process” [10]. However, using this filter “it is expected that the numbers are 50 – 70 % lower than if no filters was used” [10].

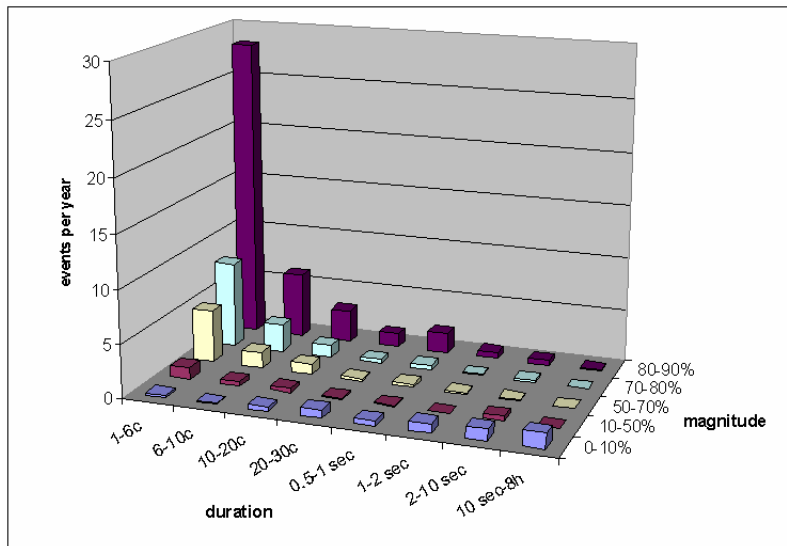

Fig. 4. EPRI data for substation monitors with a 5-min filter.

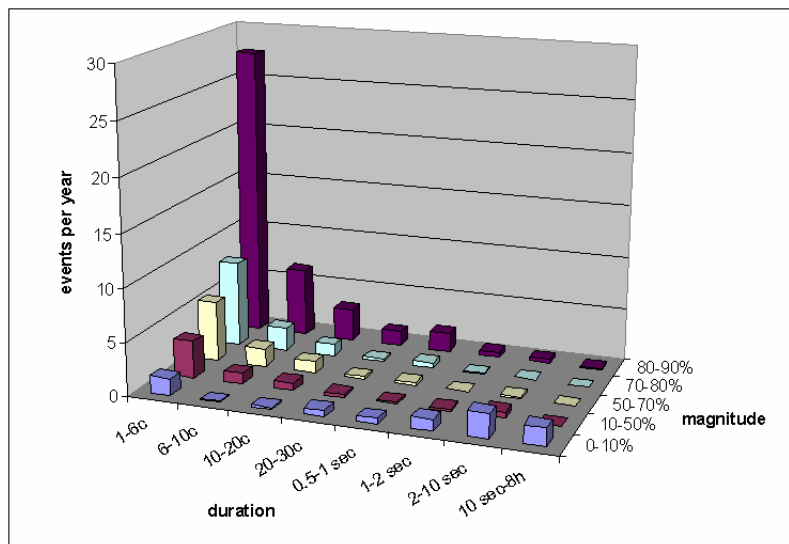

Fig. 5. EPRI data for feeder monitors with a 5-min filter.

As it can be observed in Fig. 4 and Fig. 5 the highest number of the events is characterized by drops in magnitude down to 0.8 pu from the rated voltage and with duration of maximum 6 cycles. Also, most of the events have duration up to 6 cycles especially on the feeder monitors.

2.4.2 France

A statistic regarding the number of faults per year in the whole French transmission and sub-transmission systems is presented in [11]. Here, based on the duration of the events the faults are divided mainly in two categories namely momentary and permanent fault. According to [11] the momentary fault has duration in the order of several hundreds of milliseconds and it is related to the operating time of a recloser. On the other hand a permanent fault “lasts several minutes to several hours and it requires human intervention” [11].

A summary of this fault statistic is shown in Fig. 6 based on [11].

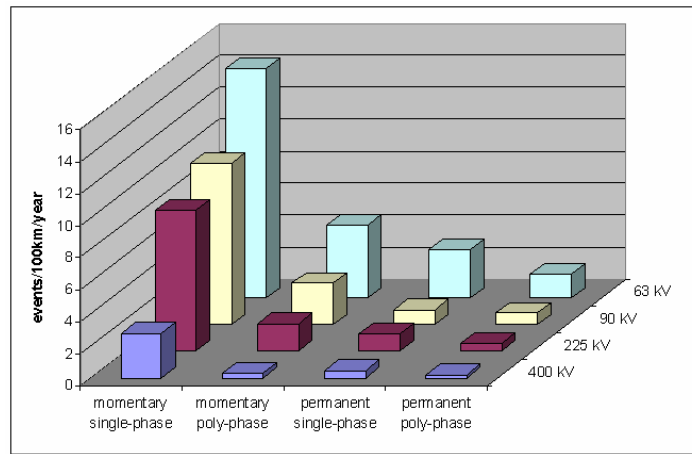

Fig. 6. Fault statistics in the France's transmission and sub-transmission lines.

It is obviously that most of the faults are located in MV networks especially momentary ones. Moreover, the frequency of the momentary single phase faults is dominant in the entire network, while the permanent poly-phase faults have the lowest occurrence.

2.4.3 Nordel

Statistics regarding the faults in the transmission system of the Nordic countries are available on Nordel's web-page [12]. Each year a document summarizing the faults in the transmission systems of the members is available from Nordel. This very comprehensive document gives in details the number of faults on each voltage level, per subcomponents, etc.

According to [12] more than 50% from the total number of faults per year in the period 2000-2005 in Denmark, Finland and Sweden are located on overhead lines as shown in Fig. 7. Exception is Norway where faults located in substations are predominant compared with faults on overhead lines.

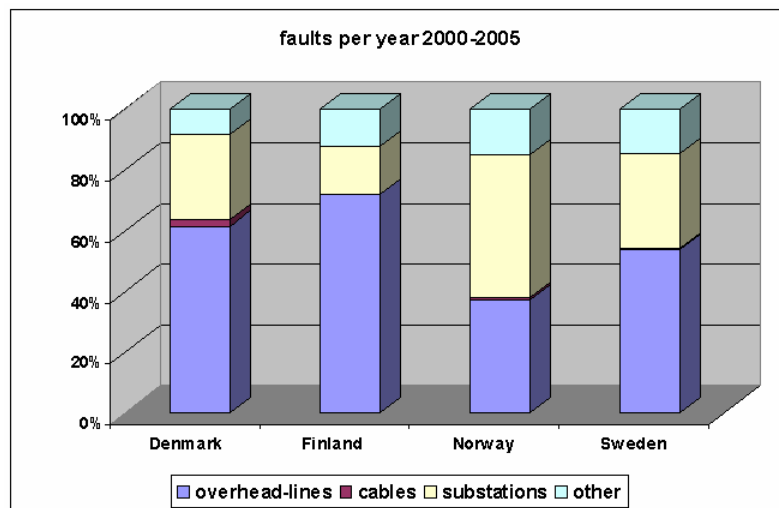

Fig. 7. Sharing of faults on the transmission systems of Nordic countries in the period 2000-2005.

In all Nordic countries the number of faults located on cables is less than 2.5% from the total number of faults in the considered period.

In all considered countries most of the faults on overhead lines in the last ten years are on 132 kV lines, while 400 kV lines are less susceptible to faults as shown in Fig. 8. Exception is Norway where the number of faults on 400 kV lines as well as on 132 kV ones are almost equal.

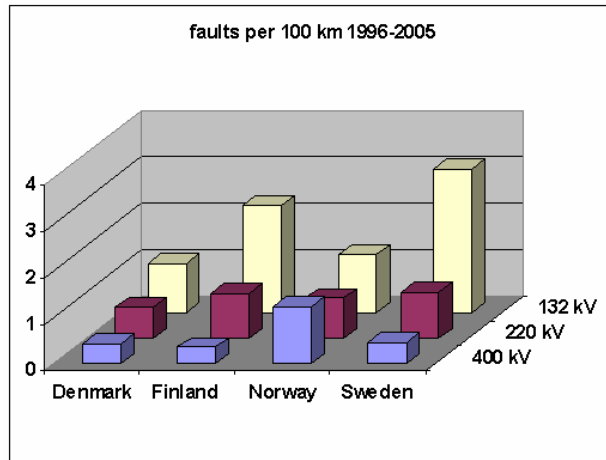

Fig. 8. Number of faults per 100km of overhead lines in the last ten years in the Nordic Countries.

An analysis of the fault type on all voltage levels in the considered Nordic Countries is given in Fig. 9, Fig. 10 and Fig. 11.

This analysis reveals that the highest number of faults is of single phase type in all considered countries.

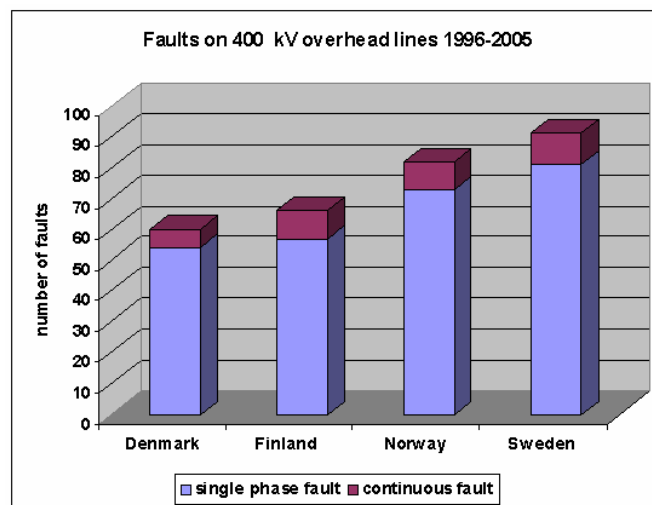

Fig. 9. Sharing of fault types on 400 kV overheads lines.

Denmark has the highest number of events on the 220 kV lines, while Sweden on the 400 kV systems.

Continuous faults have a relative low sharing in all considered countries.

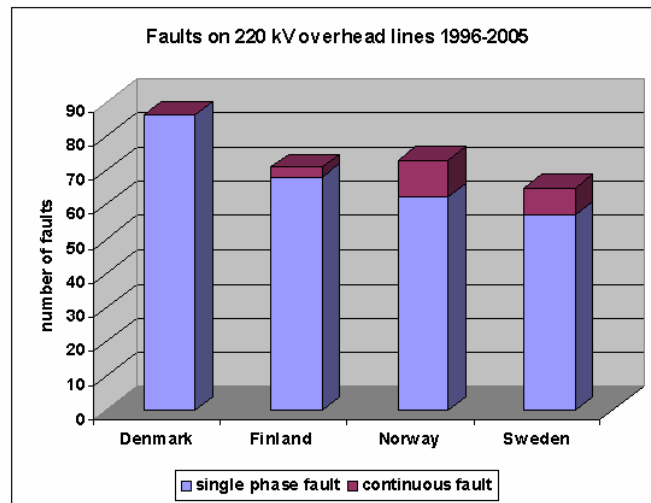

Fig. 10. Sharing of fault types on 220 kV overheads lines.

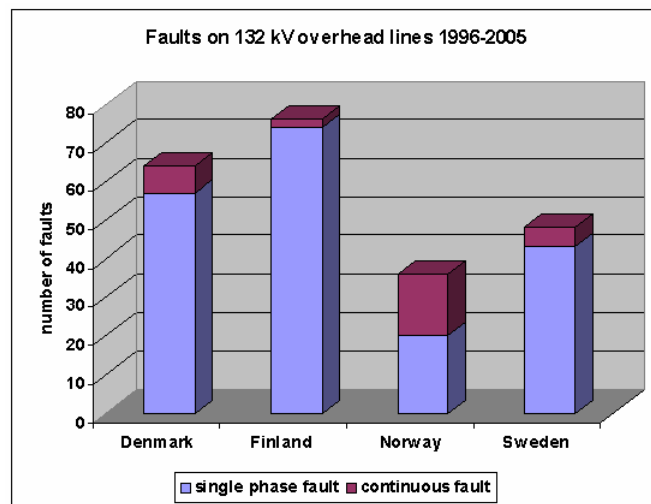

Fig. 11. Sharing of fault types on 132 kV overheads lines.

2.4.4 Summary

Based on the presented survey regarding faults on the electrical network it can be drawn the following conclusions:

- Most of the events are located on overhead lines
- Most of the faults are located on 132 kV networks.
- The single phase fault has the highest probability to occur compared with other types of faults
- Voltage drops down to 0.75 pu have a duration of several cycles while voltage drops down to 0.25 pu from the rated voltage have duration of several seconds up to minutes.

3 Requirements for LVRT Capability in National Grid Codes

In the following paragraphs an overview of the Low Voltage Ride-Through (LVRT) requirements in the national grid codes for wind turbines is presented. Some national grid codes e.g. Denmark and Ireland have specific fault ride-through requirements for distribution networks as well as for transmission ones while other national grid codes have focus only on the transmission level, e.g. Germany and Spain.

3.1 Denmark

3.1.1 Distribution System

According with the specifications from EnergyNet.dk [14] the wind turbines connected to grids with voltages below 100 kV must remain connected during grid faults as shown in Fig. 12.

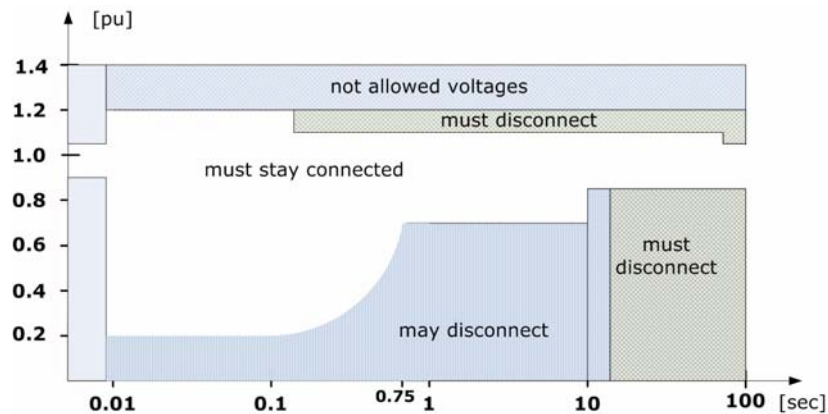

Fig. 12. Requirements for disconnection of wind turbines in the event of deviations in voltage (source [14]).

Some special situations when a WT, as well as the compensation equipment, must not be disconnected from the electrical network are specified also in [14] as follows:

- 3-phase short-circuit for 100 msec;
- 2-phase short-circuit with or without ground for 100 msec followed after 300-500 msec by a new short-circuit of 100 msec duration.

A summary of the voltage profile in these special conditions is given in Fig. 13.

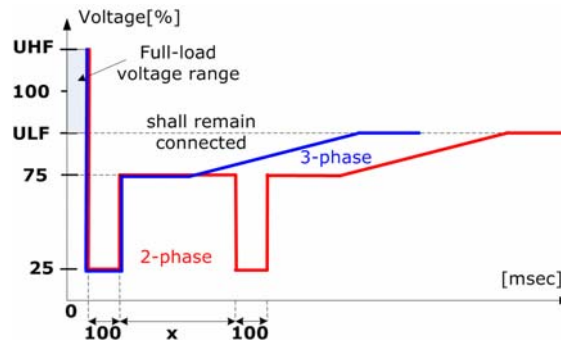

Fig. 13. Fault ride-through capabilities of WTs connected to the Distribution System.

The upper voltage limit for at full load UHF and the lower voltage limit at low load ULF in the distribution networks are defined in Table 3.

Table 3. Voltage levels in the Danish distribution networks.

Nominal voltage	Lower limit full load U_{LF}	Upper-limit full-load U_{HL}
0.4 kV	380 V	440 V
10 kV	10 kV	11 kV
15 kV	14.5 kV	16.5 kV
20 kV	20 kV	22 kV
30 kV	28.5 kV	33 kV
50 kV	47.5 kV	55 kV
60 kV	57 kV	66 kV

A wind turbine shall have sufficient capacity to fulfil the above mentioned requirements for the following sequences [14]:

- At least two 2-phases short-circuits within 2 min interval;
- At least two 3-phases short-circuit within 2 min interval.

Also, it shall be sufficient energy reserve (emergency, hydraulic and pneumatic) for the following sequences:

- At least six 2-phases short-circuits with 5 min interval;
- At least six 3-phases short-circuit with 5 min interval.

3.1.2 Transmission System

The fault ride-through requirements for wind farms connected to grids with voltages above 100 kV are specified in [15].

A wind farm shall not disconnect in the following situations:

- 3-phase short-circuit – up to 100 msec;
- 2-phase short-circuit with/without ground for up to 100 msec followed after 300-500 msec by a new short-circuit of max 100 msec duration
- 1-phase short-circuit for up to 100 msec followed after 300-500 msec by a new short-circuit of max 100 msec duration

A wind turbine shall have sufficient capacity to fulfil the above mentioned requirements for the following sequences:

- At least two 1-phase short-circuits within 2 min interval;
- At least two 2-phases short-circuits within 2 min interval;
- At least two 3-phases short-circuit within 2 min interval.

Also, it shall be sufficient energy reserve (emergency, hydraulic and pneumatic) for the following sequences:

- At least six 1-phase short-circuits with 5 min interval

- At least six 2-phases short-circuits with 5 min interval;
- At least six 3-phases short-circuit with 5 min interval.

In [15] it is specified that the basic stability proprieties which are incorporated in the design of a wind turbine shall be verified by means of a turbine test for all types of wind turbines included in the wind farm.

This turbine test “is carried out by simulation of the wind farm stability by applying a symmetric three-phase short circuit to the power grid” [15]. Additionally, the impact of asymmetrical faults, with unsuccessful automatic reclosure, on the wind farm must be documented. In this case the wind turbine shall not be disconnected from the grid.

3.1.2.1 Stability analysis during symmetric three-phase faults

According to [15] the wind farm owner must provide to the System Operator a report detailing the simulation model and results for a voltage profile with a slowly recovering time as shown in Fig. 14.

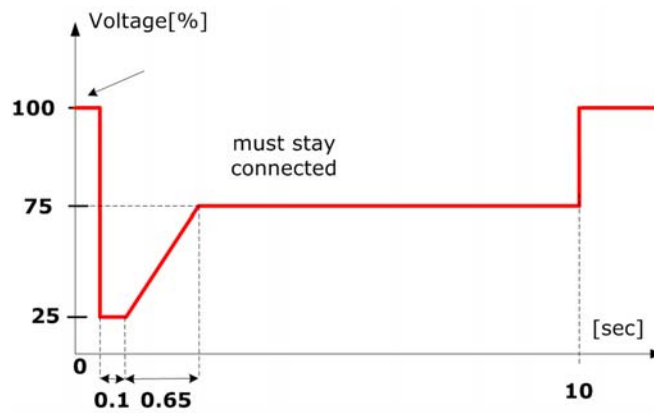

Fig. 14. Voltage profile for simulation of symmetric three-phase faults.

Simulation model shall have a structure as shown in Fig. 15. This model is based on the Thevenin equivalent of the power system.

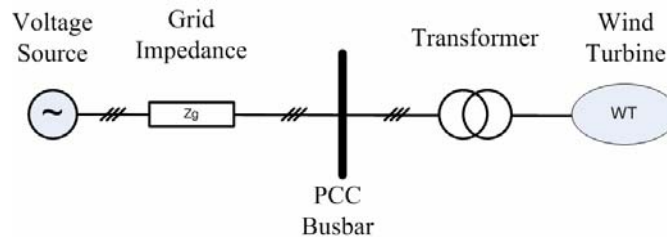

Fig. 15. Equivalent model of the power system used in stability analysis of symmetrical faults.

The voltage source shall simulate the voltage profile given in Fig. 14 with a correction factor so that the voltage level in the Point of Common Coupling (PCC) is 1 pu before the fault. The grid impedance is characterized by a short-circuit power S_k ten time bigger than the wind turbine’s rated power P_n and an impedance ratio R/X of 0.1. This impedance ratio corresponds to a grid angle of 84.3° . The report shall describe how the internal network is included in the model.

Rated wind speed, rated rotor speed and zero reactive power in the PCC are the initial conditions for the wind turbine.

In the report the simulation tool used in stability analysis shall be specified as well as a description of the wind farm model “to a level of detail that makes possible to repeat the calculation in the analysis tool of the system operator” [15].

The wind farm will meet the interconnection requirements when:

- The delivered power reaches the rated value no later than 10 sec after the voltage is above 0.9 pu:
- The active power in the PCC during the voltage dip meet the following condition:

$$P_{actual} \geq k_p \cdot P|_{t=0} \cdot \left(\frac{V_{actual}}{V|_{t=0}} \right)^2$$

where:

P_{actual} – active power in the PCC during the simulation

$P|_{t=0}$ - active power measured in the PCC before the fault

V_{actual} - voltage in the PCC during simulation

$V|_{t=0}$ - voltage measured in the PCC before fault

k_p - reduction factor considering any voltage dips to the generator terminals

- The reactive power exchange in the PCC shall be in the normal limits (see Fig. 16) no later than 10 sec after the voltage is above 0.9 pu. During the voltage dip the reactive current in the PCC shall not exceed the rated value.

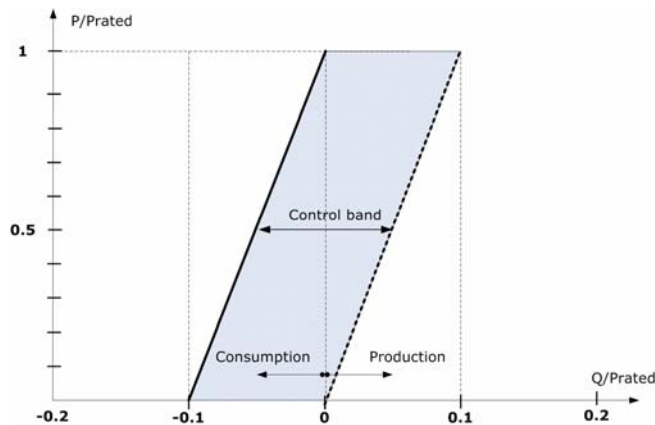

Fig. 16. Reactive power control range for normal operation of a wind turbine.

- During the voltage dip the reactive power control must be changed from normal operation to a maximum voltage support strategy so that the normal grid voltage is re-establish as soon as possible. Also, this control must be able to avoid overshoots.

3.1.2.2 Stability analysis during asymmetric faults and unsuccessful reclosure

The wind farm must be able to withstand the impacts from the asymmetric faults in the grid without requiring disconnection of wind turbines in the wind farm [15]. Two asymmetrical faults are considered here namely a two phase fault on the transmission line with unsuccessful reclosure and a single phase one in the same conditions. The voltage profile for these asymmetric faults are shown in

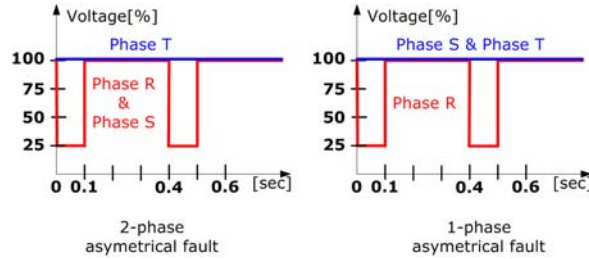

Fig. 17. Voltage profile for asymmetrical faults used in simulations.

Special remarks are made regarding the point of common coupling comparative to the transformer windings. When the PCC is on the secondary side of the transformer the vector group and phase shift of it must be considered in fault analysis. “Unless otherwise agreed, it shall be assumed that the transformer is YNd11-connected”.

3.2 Ireland

3.2.1 Distribution system

The general grid connection requirements to the Distribution System (DS) in Ireland for distributed generation as well as specific requirements for wind farms are given in [16]. These additional requirements are applied to Wind Farm Power Stations (WFPS) with Registered Capacity of 5 MW or more or with Registered Capacity less than 5MW due to be developed on a Contiguous Wind Farm Site (CWFS) where the development of the WFPS results in the total Registered Capacity of WFPS on the CWFS exceeding or remaining above 5 MW.

Based on the connection type and voltage level five categories of Wind Farm Power Stations are identified as shown in Fig. 18. The voltage profile for disconnection of these WFPS from the grid in case of a fault is summarized in Fig. 19.

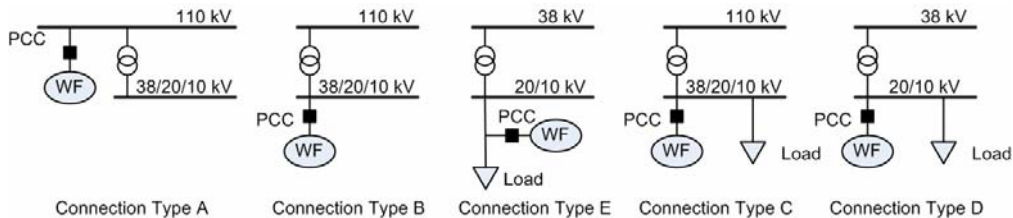

Fig. 18. Classification of Wind Farm Power Stations connected to Ireland's Distribution System.

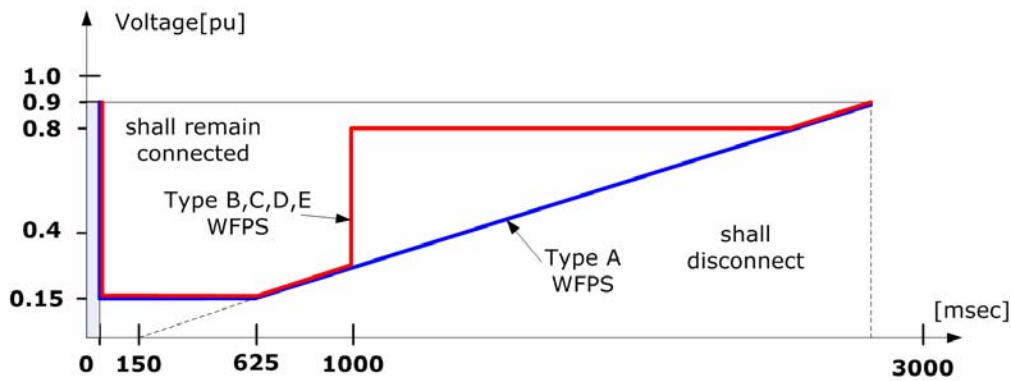

Fig. 19. Fault ride-through requirement for WFPS connected to the Ireland's distribution system

The WFPS shall remain connected to the DS for voltage dips on *any or all phases*. During the voltage dip the WFPS shall have the technical capability to provide active power in proportion to retained voltage and maximize reactive current to the DS without exceeding the WT limits for at least 600 msec or until the DS voltage recovers to the normal operational range. Moreover the WFPS shall provide at least 90% of its maximum available active power as quickly as the technology allows and in any event within 1 sec of the DS voltage recovering to the normal operating range.

3.2.2 Transmission System

The connection requirements for wind farms connected to the Transmission System are specified in [17]. These requirements are identical with those for the Distribution System [16]. However some special remarks shall be mentioned

- Voltage measurements are made in the high-voltage side of the transformer;
- Fault ride-through capabilities for all connection types are identical with the requirements valid for wind farms with connection Type A to the DS (see Fig. 18);
- Wind farms shall remain continuously connected to the TS at maximum available power or curtailed active power output for normal and disturbed system conditions and for step changes in the TS voltage of up to 10%.
- WF grid connected transformer may be connected either:
 - In delta on the LV side and in star (with the star point or neutral brought out) on the HV side
 - In star on both HV and LV sides with a delta tertiary winding provided.

3.3 Germany

In the event of faults in the grid outside the protection range of the generating plant, there must be no disconnection from the grid. The generating unit shall feed short-circuit current into the grid during the fault period. This contribution shall be agreed with E-On in each individual case.

The limit curves for the voltage pattern at the grid connection point for fault events are shown in Fig. 20.

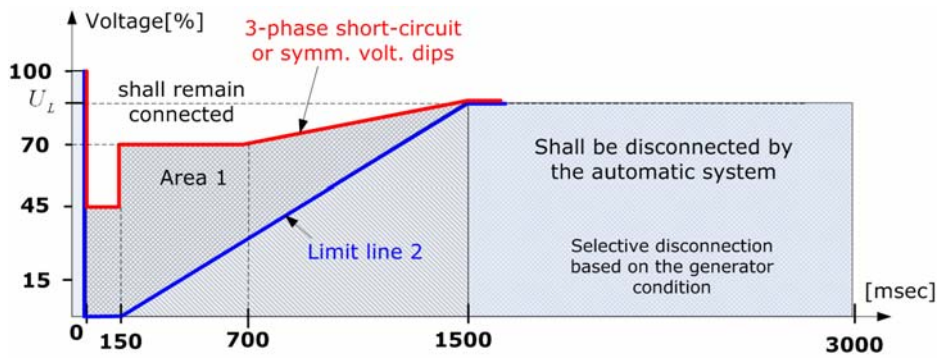

Fig. 20. Voltage limits for disconnection of generating units in the case of faults in the grid.

The highest value of the 3-phase line-to-line grid voltage is considered in Fig. 20. Three-phase short-circuits or fault related symmetrical voltage dips must not lead to instability above the red line in Fig. 20.

Special situations when the generating unit must be disconnected from the grid are considered in the following.

Voltage in the PCC has a value of and below 85% from the rated voltage and with a leading operation. The generating unit shall be disconnected after a time delay of 0.5 sec.

If the voltage on the low voltage side of each individual generator transformer falls and remains at and below 80% of the lower band of the voltage band (95%) based on a resetting ratio of 0.98, one quarter of the generators must disconnect themselves from the grid after 1.5 sec, after 1.8 sec, after 2.1 sec and after 2.4 sec respectively. The voltage value refers to the highest value of the three-phase line-to-line voltages;

If the voltage on the low voltage side of each individual generator transformer rises and remains over 120% of the upper value of the voltage band (105%) based on a resetting ratio of 1.02, the generator affected shall disconnect itself from the grid with a time delay of 100 msec. The voltage value refers to the lowest value of the three-phase line-to-line voltages

The following applies within the Area 1 in Fig. 20:

- All generating plants should experience the fault without disconnection from the grid. If, due to the grid connection concept, a generating plant cannot fulfil this requirement, it is permitted with agreement from E-On to shift the limit line while at the same time reducing the resynchronisation time and ensuring a minimum reactive power injection during the fault.
- If, when experiencing the fault, the individual generators becomes unstable or the generator protection responds, a brief disconnection of the generating plant from the grid is allowed by agreement with E-On. At the start of a brief disconnection resynchronisation of the generating plant shall take place within 2 seconds at the latest. The active power infeed must be increased to the original value with a gradient of at least 10% of the rated generator power per second.

The generating plants shall support the grid voltage with additional reactive current during a voltage dip. The voltage control in this case shall act as shown in Fig. 21 and must take place within 20 msec after fault recognition. The generator unit shall provide a reactive current on the low voltage side of the transformer equal to at least 2% from the

rated current for each percent of the voltage dip. If necessary the generating unit shall be able to provide full rated reactive current

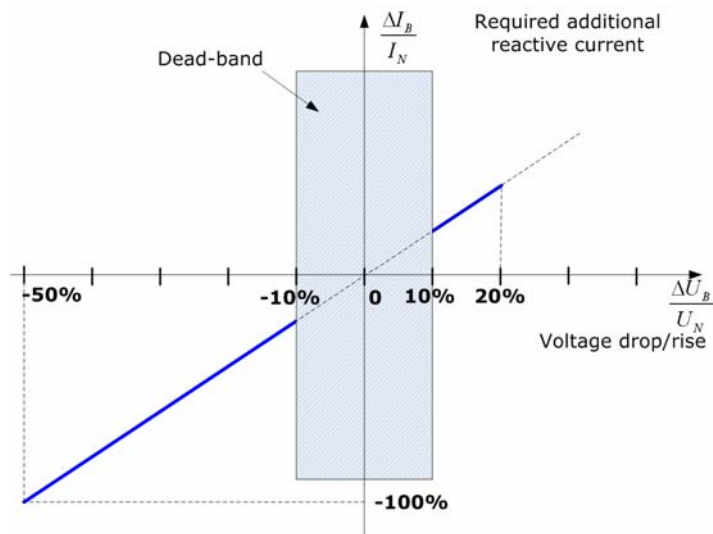

Fig. 21. Voltage support requirement from E.On Netz during grid faults.

After the voltage returns to the dead-band, the voltage support shall be maintained for a further 500 msec.

3.4 Great Britain

The interconnection requirements for the transmission system in Great Britain (GB) are given in [21]. However, for connection of embedded generators below a certain power level e.g. 30 MW the Distribution System Operators in particular regions shall be contacted [21]. Also the interconnection requirements are different for different regions in GB, e.g. England and Wales, and Scotland. In the following paragraphs a summary of the most important grid connection requirements for distributed sources with a completion date after 1 January 2006 are presented.

Generating units shall remain connected and transiently stable without tripping for a close-up solid three-phase short circuit fault or any unbalanced short-circuit fault on the transmission system operating at supergrid voltages for a total fault clearance time of up to 140 msec. The duration of zero voltage is dependent on local protection and circuit breaker operating times. This duration and the fault clearance time will be specified in the individual agreement between TSO and the owner of the production unit. Following fault clearance, recovery of the supergrid voltage to 90% may take longer than 140 msec as illustrated in Fig. 22

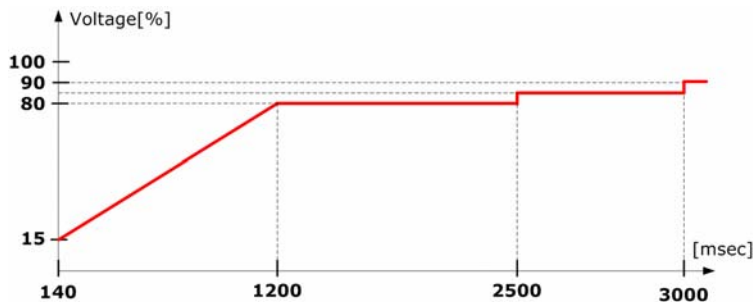

Fig. 22. Requirement for fault ride through capability in the GB networks.

Same requirements as above are valid for voltage dips greater than 140 msec in duration.

In order to avoid unwanted island operation the generating units in Scotland shall be tripped for the following conditions:

- Voltage as measured in the PCC below 80% for more than 2 sec;
- Voltage as measured in the PCC above 120% (115% for 275 kV) for more than 1 sec.

3.5 Spain

A document detailing the minimal interconnection requirements for wind turbines has been issued by REE Spain [22] and it was published officially in October 2006. This document addressed just two topics namely fault ride-through capabilities and reactive power/voltage control during faults and it applies to all operators connected to the main transmission grid. However according with [27] “REE is considering including wind plant connected” at the distribution system level.

The wind turbines shall remain connected during faults for a voltage profile as shown in Fig. 23. There is no specification regarding the procedure for calculation of voltages during the fault.

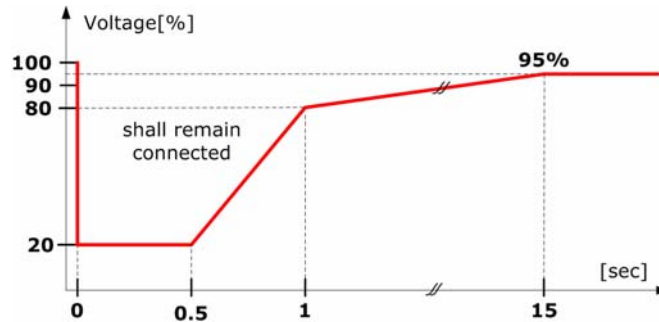

Fig. 23. Fault ride-through requirement for wind turbines in the Spanish transmission grid.

The wind power plants are required to stop drawing the reactive power within 100 msec of a drop voltage and to be able to inject reactive power within 150 msec of grid recovery as shown in Fig. 24.

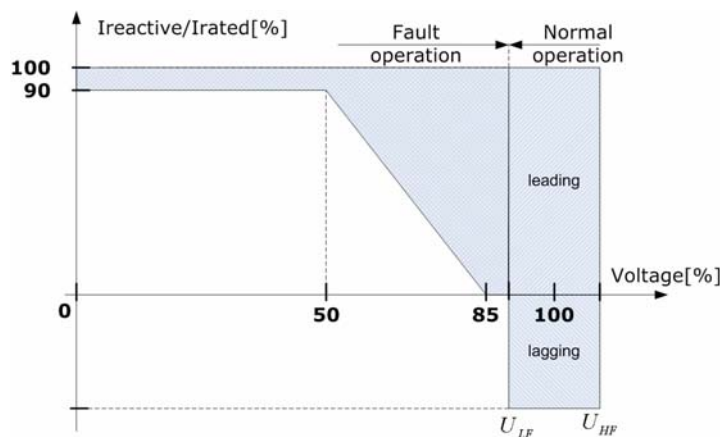

Fig. 24. Grid support during faults by reactive current injection as specified in the Spanish grid codes.

3.6 Italy

The general rules for connecting to the transmission system in Italy are given in [23], [24] and [25]. A draft document with connection requirements for wind power was issued in February 2006 [26]. The document is addressed to wind power installations with a rated power over 25 MW connected to voltage levels up to 30 kV

The voltage profile for the fault ride-through capability of the wind turbines is given in Fig. 25.

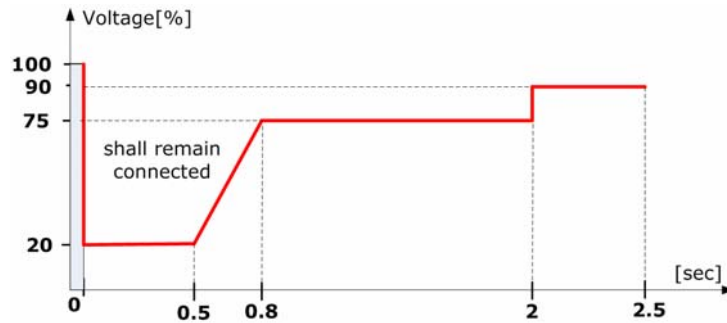

Fig. 25. Voltage profile for fault ride-through capability

3.7 USA

The interconnection requirements for wind energy connected to the transmission networks are defined in [28] issued by Federal Energy Regulatory Commission (FERC) in US. These requirements are applicable to wind power facilities larger than 20 MW. This document addresses mainly three topics namely the low voltage ride-through capability, power factor design criteria and Supervisory control and data acquisition capability.

According with this document the wind power plants “shall be able to remain online during voltage disturbances up to the time periods and associated voltage levels” as shown in Fig. 26. Also the “wind generating plant must be able to operate continuously at 90% of the rated line voltage, measured at the high voltage side of the wind plant substation transformer” [28].

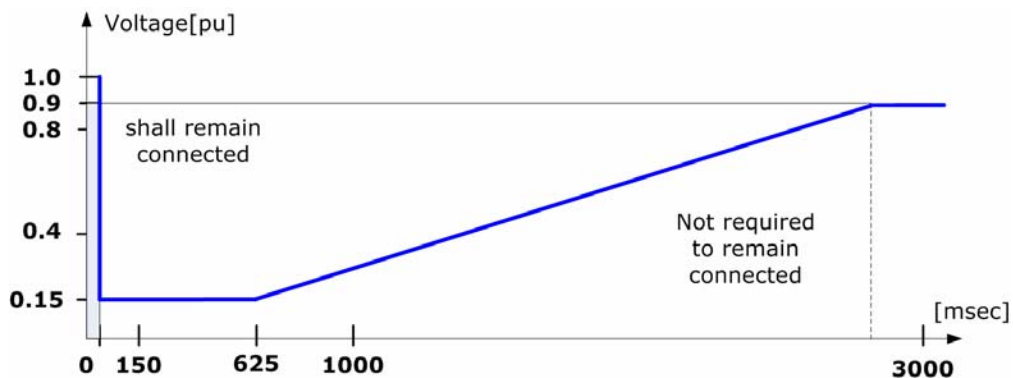

Fig. 26. Minimum required wind plant response to emergency low voltage.

As it can be seen in Fig. 26 the Low Voltage Ride-Through capability is similar with Ireland’s requirements for Wind Farm Power Stations with a Connection Type A.

FERC has also issued specific interconnection requirements for small generators with registered capacity of less than 20 MW.

3.8 Canada

A comprehensive study regarding the status of the wind power penetration into the Canadian power system as well as further development is given in [29]. The existing installed wind power is shared uneven among the 13 Canadian provinces. According to [29] there were 570 MW installed wind power capacity across Canada in 2005, Alberta and Quebec having most of this installed power; 275 MW and 212 MW respectively. Another approximately 2 GW are “under construction or have secured power purchase agreements” [29]. The existing grid connection requirements reflect also this situation. Thus, just Alberta, Ontario and Quebec have specific interconnection requirements for wind power issued in the last 3 years [30], [31]. However, the Low Voltage-Ride Through capability for wind power is well-defined only for Alberta and Quebec [30], [31].

3.8.1 Hydro-Quebec

Hydro-Quebec’s LVRT requirement is defined for “the positive sequence voltage on the high-voltage side of the switchyard” [30] as given in Fig. 27. According to [30] the wind generators must remain to the transmission system without tripping during:

- A three-phase fault cleared in 9 Cycles including a fault on the high-voltage side of the switchyard and for the time required to restore voltage after the fault is cleared as specified in Fig. 27 for the positive-sequence voltage;
- A two-phase-to-ground fault or a phase-to-phase fault cleared in 9 cycles including a fault on the high-voltage side of the switchyard and for the time required to restore voltage after the fault is cleared;
- A single-phase-to-ground fault cleared in 15 cycles including a fault on the high-voltage side of the switchyard and for the time required to restore voltage after the fault is cleared.

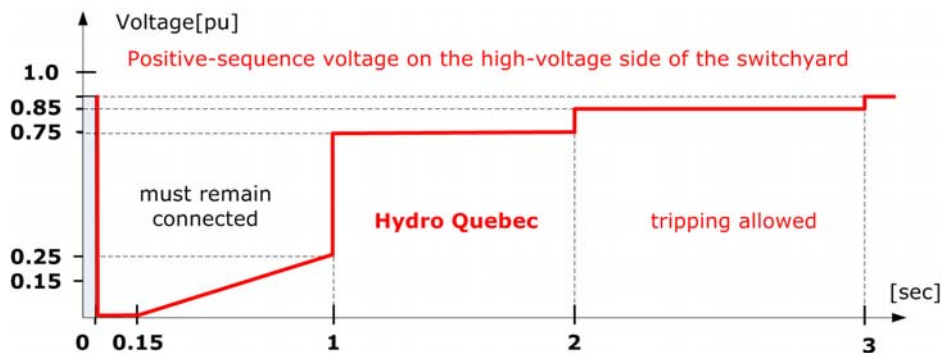

Fig. 27. LVRT requirement from Hydro-Quebec for wind generators during a three-phase fault.

Also, the wind generators must remain in service without tripping during a remote fault cleared by slow protective device (up to 45 cycles) and for the time required to restore voltage after the fault is cleared, whether the remote fault is:

- A three-phase fault, if the positive-sequence voltage on the high-voltage side of the switchyard does not fall below 0.25 pu;

- A two-phase-to-ground fault, if the positive-sequence voltage on the high-voltage side of the switchyard does not fall below 0.5 pu;
- A phase-to-phase fault if the positive-sequence voltage on the high-voltage side of the switchyard does not fall below 0.6 pu.

The following statement in [30] must be mentioned: “Power producer facilities must also help restore the power system to normal operating conditions after a disturbance”. However, no details for clarifying how the wind power facility shall help the restoration of the power system after disturbances are given. Under the requirements concerning voltage regulation and power factor is stated that the power producer facilities can supply or absorb reactive power corresponding to a power factor equal or less than 0.95 on the high-voltage side of the wind power plant switchyard.

3.8.2 AESO-Alberta

The LVRT requirement for Alberta [31] applies to voltage at the PCC and all transmission connected wind farms above 5 MW capacity, as shown in Fig. 28.

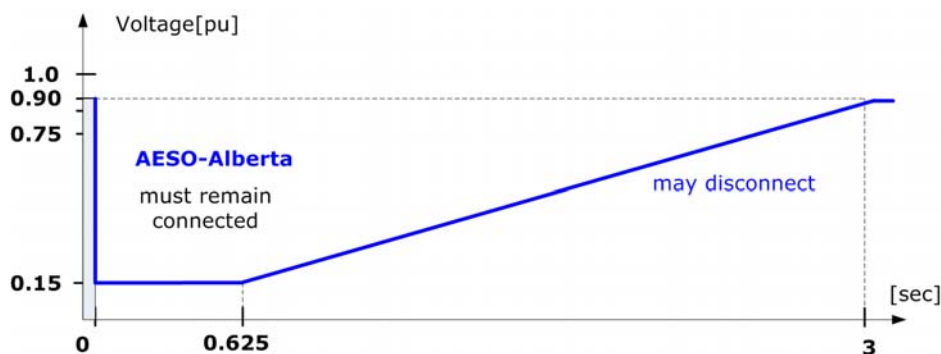

Fig. 28. Voltage ride-through requirements from AESO-Alberta for low voltage conditions.

A wind power farm shall not trip any loaded wind turbine generators for voltage dips resulting from normally cleared transmission faults on any phase or combination of phases at or beyond the point of connection.

The following exceptions are given in [31] for wind power farms:

- Are not required to ride-through transmission system faults that cause a forced outage of a radial line to the farm;
- Are not expected to ride-through faults that occur on the lower voltage networks of the farm

3.8.3 IESO-Ontario

According to Garrad Hassan’s study [29] the Independent System Operator (IESO) has issued in July 2005 a document regarding interconnection requirements for wind power in Ontario province entitled “Summary of IESO Reliability Requirements for Wind Generation Installations”. “The generation units are required to ride-through contingencies on the system resulting in low voltage” [29]. However, “no further detail of the requirement is given” [29].

3.8.4 Conclusions

Garrad Hassan concludes in [29] that “the Quebec LVRT requirement is likely to become standard across many Canadian provinces and that Alberta and other grid codes will cede to this”.

3.9 Summary

All considered grid codes require fault ride-through capabilities for wind turbines. A summary of these requirements is given in Table 4. Voltage profiles are given specifying the depth of the voltage dip and the clearance time as well. However, in some of the grid codes the calculation of the voltage during all types of unsymmetrical faults is very well defined e.g Ireland, while others does not define clearly this procedure.

Table 4. Summary of ride-through capability for wind turbines/farms in different national grid codes.

Country	Voltage Level	Fault ride-through capability				
		Fault duration	Voltage drop level	Recovery time	Voltage profile	Reactive current injection
Denmark	DS	100 msec	25%U _r	1 sec	2, 3-ph	no
	TS	100 msec	25%U _r	1 sec	1, 2, 3-ph	no
Ireland	DS/TS	625 msec	15%U _r	3 sec	1, 2, 3- ph	no
Germany	DS/TS	150 msec	0%U _r	1.5 sec	generic	Up to 100%
Great Britain	DS/TS	140 msec	15%U _r	1.2 sec	generic	no
Spain	TS	500 msec	20%U _r	1 sec	generic	Up to 100%
Italy	> 35 kV	500 msec	20%U _r	0.3 sec	generic	no
USA	TS	625 msec	15%U _r	2.3 sec	generic	no
Ontario	TS	625 msec	15%U _r	-	-	no
Quebec	TS	150 msec	0%U _r	0.18 sec	Positive-sequence	no

The voltage profile for ride-through capability can be summarized as shown in Fig. 29. Ireland’s grid code is very demanding in respect with the fault duration while Denmark has the lowest short circuit time duration with only 100 msec. However, Denmark’s grid code requires that the wind turbine shall remain connected to the electrical network during successive faults. The German grid code requires to wind power installations to remain connected during voltage sags down to 0% from the rated voltage in the PCC for a duration of 150 msec. Moreover, during the fault a reactive current injection up to 100% is required. Same requirement regarding reactive current injection is present in the Spanish grid code. This demand is relative difficult to meet by some of the wind turbine concepts e.g. active stall wind turbine with directly grid connected squirrel cage or doubly fed induction generator based wind turbines.

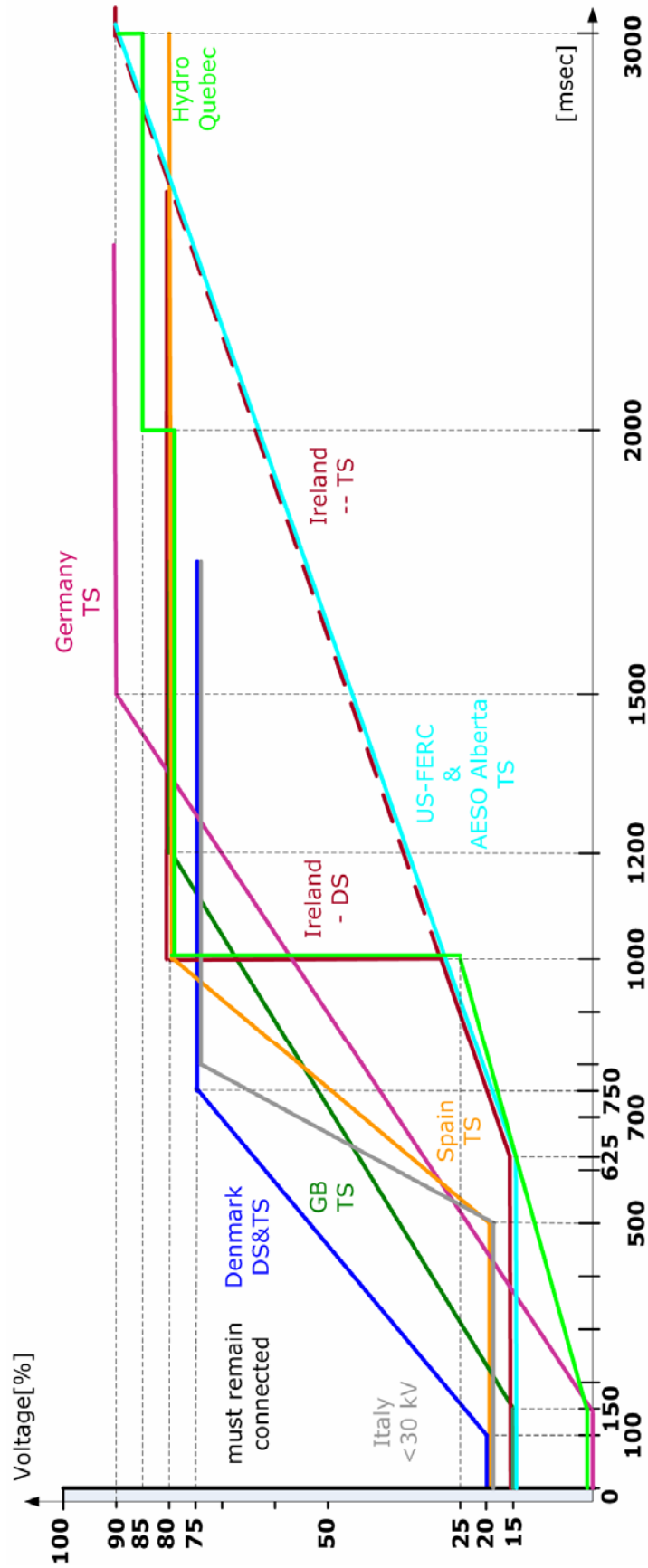

Fig. 29. Summary regarding fault ride through capability of wind turbines/farms in National Grid Codes.

4 Fault analysis

In this chapter a study regarding the response of the directly grid-connected induction generator during faults is presented. The focus here is on studying the interaction between the mechanical part and the electrical one in a wind turbine.

4.1 Simulation Model

In order to analyze the response of a wind turbine during faults an active stall directly grid connected wind turbine with a squirrel-cage induction generator has been considered. A block diagram of the system is shown in Fig. 30.

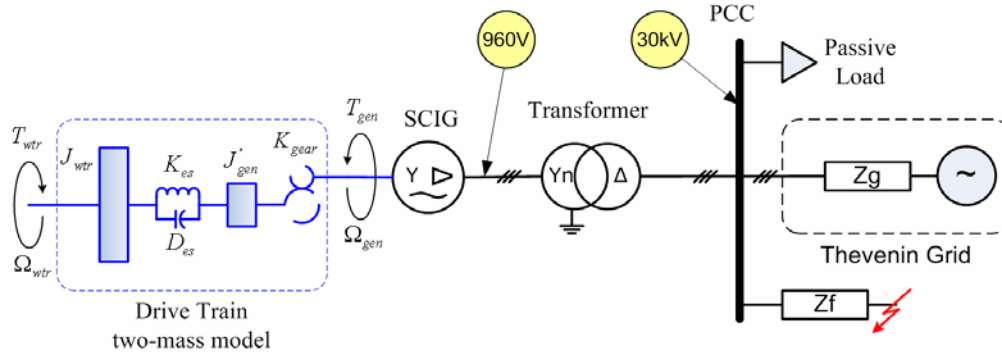

Fig. 30. Block diagram of the directly grid connected wind turbine with a squirrel-cage induction generator used in fault analysis.

The system comprises of a 2MW squirrel-cage induction generator connected through a 2 MW transformer with a Dyn 11 connection to the Point of Common Coupling. An equivalent Thevenin grid characterized by a short-circuit power of 20 MVA and a grid impedance with a ratio R_g / X_g of 0.1 have been considered. This impedance ratio corresponds to a value of 83.4° for the grid voltage angle in the PCC while the short circuit power is ten times greater than the rated power of the wind turbine as recommended in [15]. A passive load with a rated power of 5% from the short circuit power of the grid and a power factor of 0.86 is also connected in the PCC. The short circuit path has an impedance ratio R_f / X_f of 0.2.

This system is modelled in Matlab/Simulink using the models developed in Simulation Platform project [32].

A two mass model is considered for the wind turbine drive drain, while the squirrel-cage induction generator is modelled in phase coordinates ABC/abc and takes into account the connection type of the stator windings [32].

A model in phase coordinates ABC/abc is also considered for the transformer. It is based only on parameters from standard data-sheets and accounts for core geometry and iron losses [32]. The saturation and the hysteresis effect are not considered in modelling. Moreover, the connection type of the windings is taken into account.

The short circuit path for all types of fault is modelled as shown in Table 5. The short circuit resistance R_f has been selected in each case so that the voltage dip in the considered phases is 25% from the rated voltage on the PCC as shown in Fig. 31.

Table 5. Modelling of short-circuit paths for different fault types.

Short-Circuit Type	Equivalent diagram	Mathematical equations
Three-phase short-circuit	<p>PCC</p>	$v_R = v_S = v_T = 0$ $i_{fR} + i_{fS} + i_{fT} = 0$
Two-phase short circuit with ground	<p>PCC</p>	$v_S = v_T = 0$ $i_{fR} = 0$ $i_{fS} + i_{fT} = 0$
Two-phase short circuit without ground	<p>PCC</p>	$v_S = v_T \neq 0$ $i_{fR} = 0$ $i_{fS} + i_{fT} = 0$
Single-phase short circuit	<p>PCC</p>	$v_R = 0$ $i_{fR} \neq 0$ $i_{fS} = i_{fT} = 0$

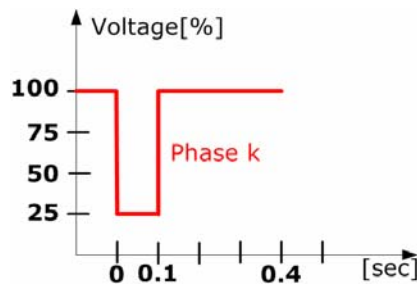

Fig. 31. Voltage profile for phase k during fault in the PCC.

Exception is the two-phase short-circuit without ground where due to the fault configuration the voltage dip is 50% from its rated value.

Since the pitch control for this type of wind turbines has usually a gradient of 8 deg per min it has been assumed that the wind turbine torque during the faults is constant. Two main situations are considered here, namely a 1 pu driven torque at the low speed shaft and a 0.25 pu driven torque respectively.

4.2 Study cases

Using the developed model all short-circuit types have been studied. In the following the relevant waveforms from the systems are shown, namely:

- RMS values of the voltages in the PCC (MV side)
- RMS values of the voltages in the secondary side of the transformer (LV side)
- Mechanical speed at the high speed shaft (generator speed)
- Mechanical speed at the low speed shaft (wind turbine speed)
- Electromagnetic torque of the generator.
- Shaft torque in the drive train

4.2.1 Three-phase short-circuit at 1 pu driven torque

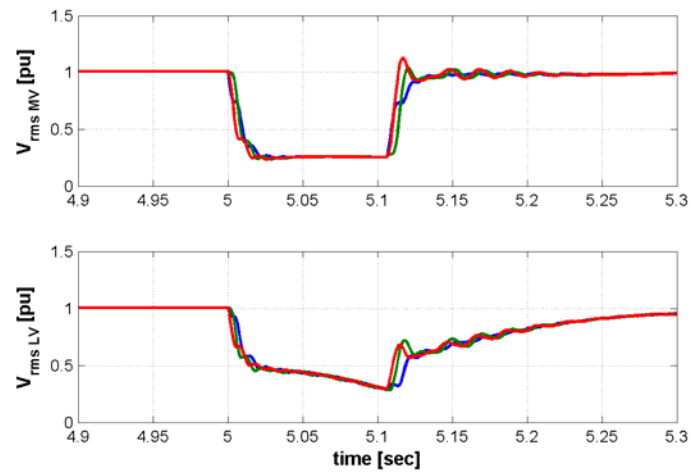

Fig. 32. Voltage profile on the MV and LV side during a three-phase fault in the PCC.

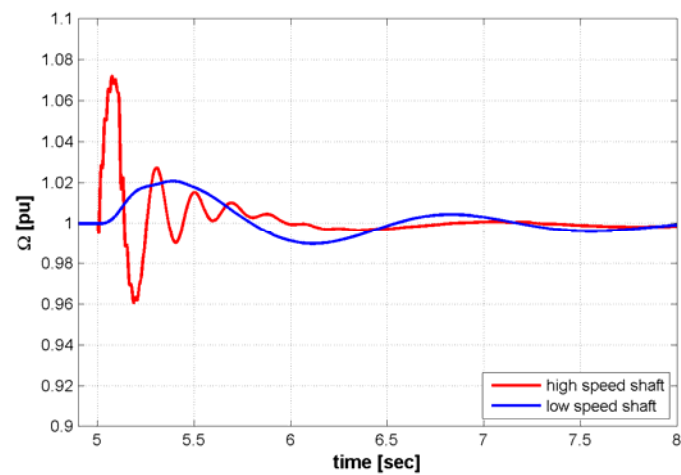

Fig. 33. Wind turbine and generator speed during a three-phase fault in the PCC.

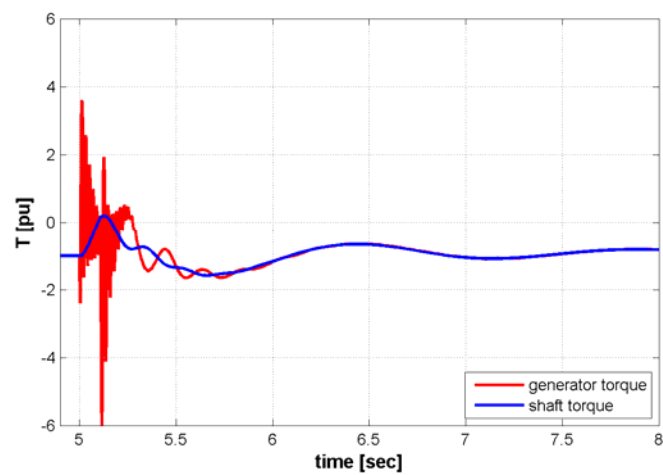

Fig. 34. Shaft and generator torque during a three-phase fault in the PCC.

4.2.2 Two-phase short-circuit with ground at 1 pu driven torque

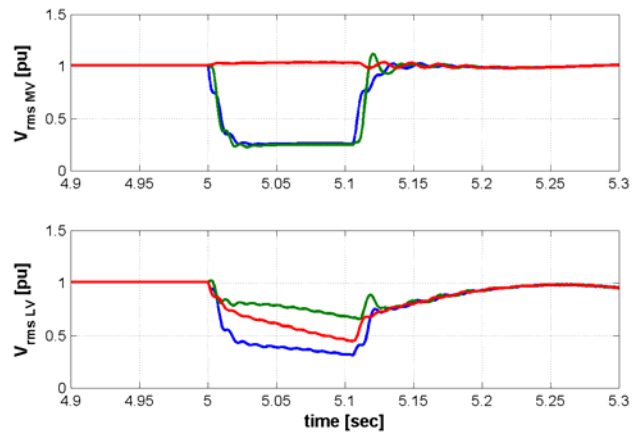

Fig. 35. Voltage profile on the MV and LV during a two-phase fault with ground in the PCC.

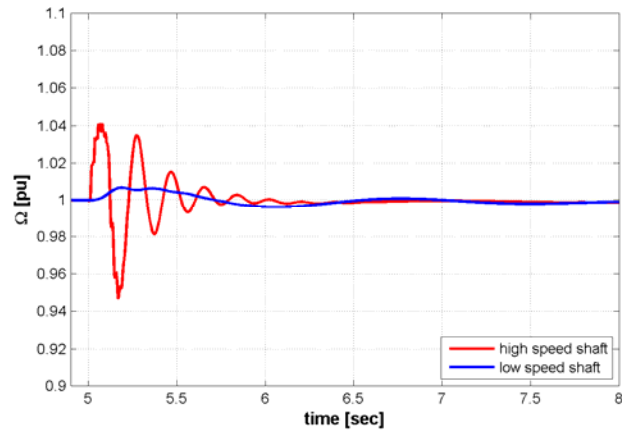

Fig. 36. Wind turbine and generator speed during a two-phase fault with ground in the PCC.

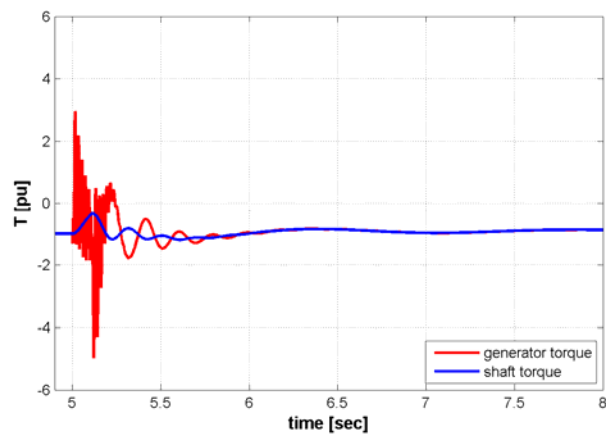

Fig. 37. Wind turbine speed and generator speed and torque during a two-phase fault with ground in the PCC.

4.2.3 Two-phase short-circuit without ground at 1 pu driven torque

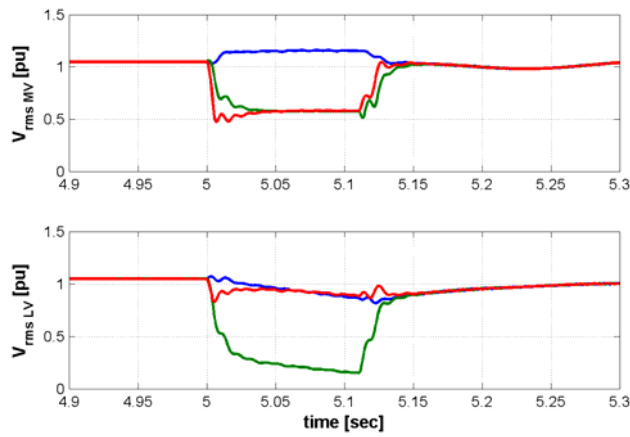

Fig. 38. Voltage profile on the MV and LV side during a two-phase fault without ground in the PCC.

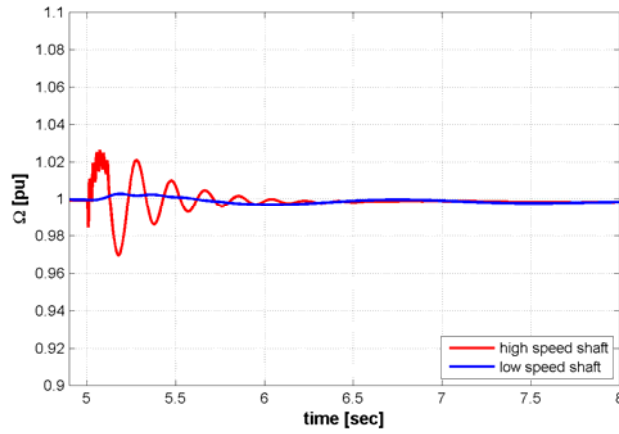

Fig. 39. Wind turbine and generator speed during a two-phase fault without ground in the PCC.

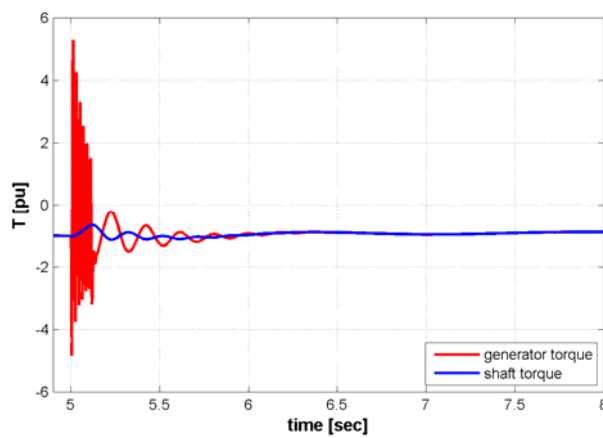

Fig. 40. Shaft and generator torque during a two-phase fault without ground in the PCC.

4.2.4 Single phase short-circuit at 1 pu driven torque

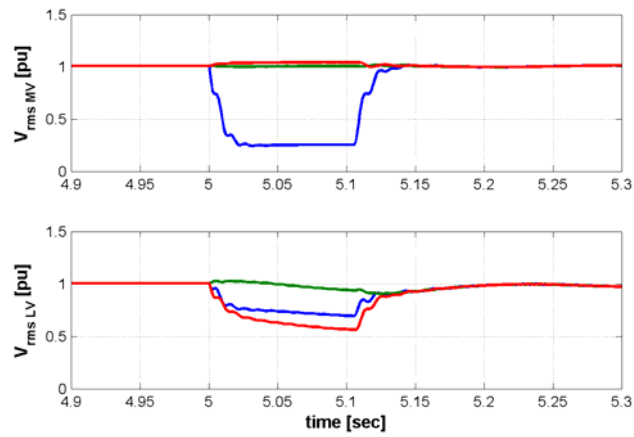

Fig. 41. Voltage profile on the MV and LV side during a single-phase fault in the PCC.

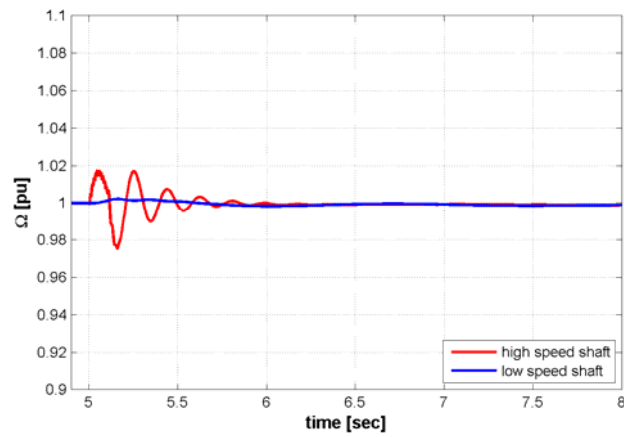

Fig. 42. Wind turbine and generator speed during a single-phase fault in the PCC.

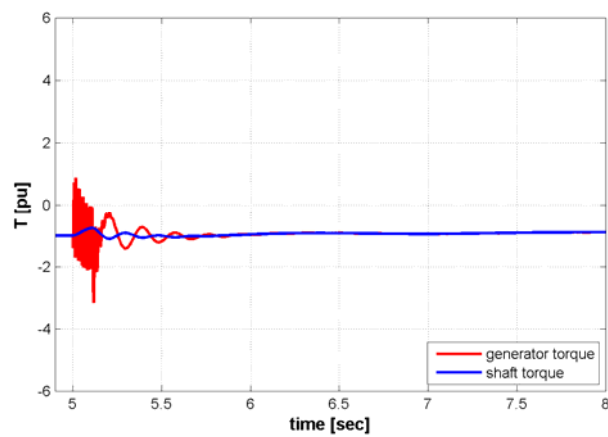

Fig. 43. Shaft and generator torque during a single-phase fault in the PCC.

4.2.5 Three-phase short-circuit at 0.25 pu driven torque

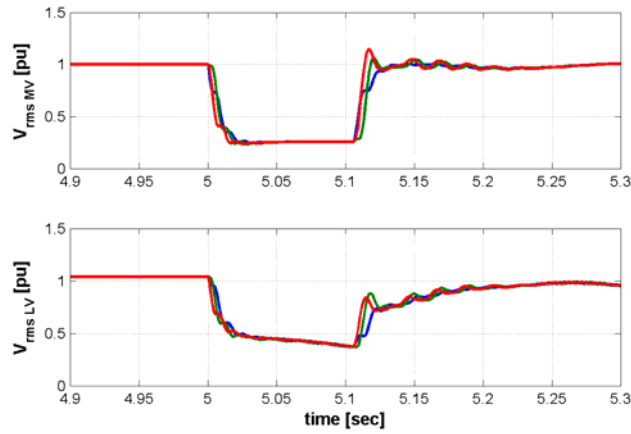

Fig. 44. Voltage profile on the MV and LV side during a three-phase fault in the PCC.

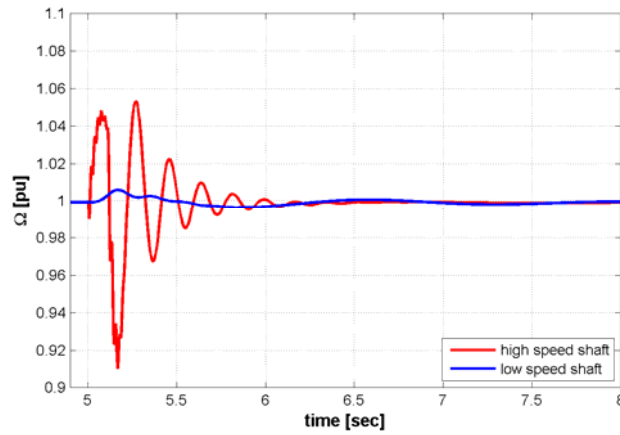

Fig. 45. Wind turbine and generator speed during a three-phase fault in the PCC

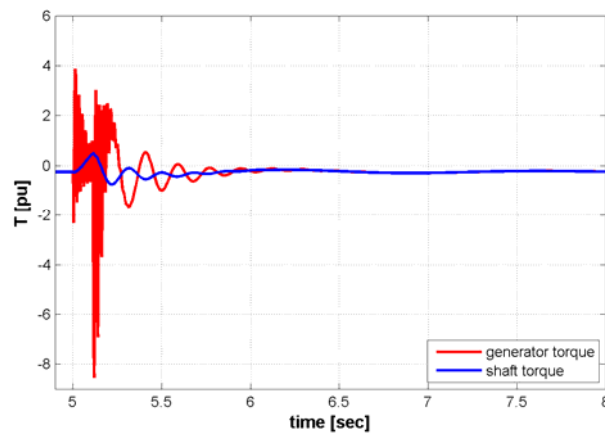

Fig. 46. Shaft and generator torque during a three-phase fault in the PCC.

4.3 Conclusions

The connection type of the wind turbine's transformer namely Dyn11 has a big impact on the propagation of the voltage drop to the generator terminals. All asymmetrical faults are "seen" by the generator with a smaller drop than a three-phase short-circuit. As a result, the oscillations in electromagnetic torque are not so high. Furthermore, the amplitude of speed variations at the low speed shaft is reduced for asymmetrical faults compared with three-phase one.

Due to the short-circuit path a two phase fault without ground will not produce a voltage drop lower than 0.5 pu from the rated voltage. However, among all the asymmetrical faults this short-circuit exhibits very large excursion of the electromagnetic torque, while the generator speed vary less than in the case of a two-phase short-circuit with ground. Despite of the voltage drop down to 0.25 pu from the rated voltage in the PCC, the single phase fault due to the connection type of the transformer will give the lowest variations both in electromagnetical torque and generator speed.

5 General Conclusions

Currently, more grid operators are changing the interconnection requirements for wind power, especially for the transmission systems. This is an obvious signal that more wind power will enter into the electrical system in the near future. These requirements in most of the cases are specifically addressed to the ride-through capabilities of wind power installations. According to these demands a wind turbine/farm must withstand short-circuits with different voltage drops and recovery times. It is difficult to compare all these requirements because in most of the cases the procedure of calculating/measuring the voltage in the Point of Common Coupling is not very well defined.

On the other hand many references consider that the present grid codes often contain costly and demanding requirements e.g. fault ride-through capability and primary control which are not reflecting the real penetration of the wind power in a given area or the real impact of a short-circuit on the wind turbine interaction with the electrical grid.

According with the surveys presented in this report, it is obvious that most of the events in the network are single phase faults not necessary located at the PCC of a wind turbine/farm. Due to the connection of the transformer's windings these types of faults will not have a big impact on the mechanical structure of the wind turbine. On the other hand based on the simulation studies presented in chapter 4 it can be concluded that the three-phase short-circuit at low wind speed and hence low driving torque may have the biggest impact on the mechanical part producing high torque oscillations in the drive-train and a high stress in the gear-box due to the motoring mode of operation.

References

- [1]. European Commission – New ERA for electricity in Europe. Distributed Generation: Key Issues, Challenges and Proposed Solutions, EUR 20901, 2003, ISBN 92-894-6262-0;
- [2]. EWEA Large scale integration of wind energy in the European Power Supply; December 2005;
- [3]. *** - Variability of wind power and other renewables. Management options and strategies. IEA, www.iea.org;
- [4]. M. H. J. Bollen – Understanding Power Quality Problems. Voltage sags and interruptions, IEEE Press Series on Power Engineering, 2000, ISBN 0-7803-4713-7;
- [5]. DS/EN 50160 – Voltage characteristics of electricity supplied by public distribution systems, 2nd edition, June 2000;
- [6]. IEEE Std. 1159/1995 – IEEE Recommended Practice for Monitoring Electric Power Quality, June 1995;
- [7]. IEEE Std. 1250-1995 – IEEE Guide for service to equipment sensitive to momentary voltage disturbances, March 1995;
- [8]. Myo Thu Aung, Jovica Milanovic – The influence of transformer winding connection on the propagation of voltage sags, IEEE Trans on Power Delivery, vol. 21, no. 1, January 2006, pp.262-269;
- [9]. D.S. Dorr – Point of Utilization Power Quality Study results, IEEE Trans on Industry Applications, vol. 3, no. 4, July/August 1995, pp. 658-666;
- [10]. D.S. Dorr, M.B. Hughes, T.M. Gruz, R.E. Jurewicz, J.L. McClaine – Interpreting Recent Power Quality Surveys to Define the Electrical Environment, IEEE Trans on Industry Applications, vol. 33, no. 6, November/December 1997, pp. 1480-1487;
- [11]. CRISP – Distributed Intelligence in Critical Infrastructures for Sustainable Power, Functional specifications of electric networks with high degrees of distributed generation, Deliverable D1.1, ENK8-CT-2002-00673, June 2003.
- [12]. www.nordel.org;
- [13]. M.J. Voeten – 16 years of fault statistics in the Dutch LV, MV and HV distribution networks
- [14]. EnergiNet – Grid connection of wind turbines to networks with voltages below 100 kV, Regulation TF 3.2.6, May 2004, p. 29;
- [15]. Energinet - Grid connection of wind turbines to networks with voltages above 100 kV, Regulation TF 3.2.5, December 2004, p. 25;
- [16]. ESB Networks – Distribution Code, version 1.4, February 2005;
- [17]. CER – Wind Farm Transmission Grid Code Provisions, July 2004;
- [18]. E.ON-Netz – Grid Code. High and extra high voltage, April 2006;
- [19]. VDN – Transmission Code 2003. Network and System Rules of the German Transmission System Operators, August 2003;
- [20]. VDN – Distribution Code 2003. Rules on access to distribution networks, August 2003;
- [21]. National Grid Electricity Transmission plc – The grid code, Issue 3, Revision 17, September 2006;
- [22]. REE – Requisitos de respuesta frente a huecos de tensión de las instalaciones de producción de régimen especial, PO 12.3, November 2005;
- [23]. ENEL – DK 5400 - Criteri di allacciamento di clienti alla rete AT della distribuzione, October 2004;
- [24]. ENEL - – DK 5740 - Criteri di allacciamento di impianti di produzione alla rete MT di ENEL distribuzione, February 2005;

- [25]. TERNA - Codice di trasmissione, dispacciamento, sviluppo e sicurezza della rete, 2006;
- [26]. CEI 11/32, Appendice N.6 – Normativa impianti di produzione eolica, February 2006 (draft);
- [27]. *** - Going mainstream at the grid face. Examining grid codes for wind, *Windpower Monthly*, September 2005;
- [28]. FERC – Interconnection of Wind Energy, 18 CFR Part 35, Docket No. RM05-4-001; Order No. 661-A December 12, 2005;
- [29]. CanWEA - Canadian Grid Code for Wind Development Review and Recommendations, Document no. 11163/OR/01 B, 2005 Garrad Hassan Canada Inc.;
- [30]. Hydro-Québec TransÉnergie – Transmission Provider Technical Requirements for the connection of power plants to the Hydro-Québec Transmission System, March 2006;
- [31]. Alberta Electric System Operator – Wind Power Facility. Technical Requirements, Revision 0, November 2004;
- [32]. F. Iov, A.D. Hansen, P. Sørensen, F. Blaabjerg - *Wind Turbine Blockset in Matlab/Simulink. General Overview and Description of the Models* -, Aalborg University, ISBN 87-89179-46-3;
- [33]. A.D. Hansen, P. Sørensen, F. Iov, F. Blaabjerg – Centralised power control of wind farms with doubly-fed induction generators, *Journal of Renewable Energy*, Elsevier Science, Oxford, Vol. 31, No. 7, 2006, pp. 935-951, ISSN 0960-14811

Risø's research is aimed at solving concrete problems in the society.

Research targets are set through continuous dialogue with business, the political system and researchers.

The effects of our research are sustainable energy supply and new technology for the health sector.

