

Technical University of Denmark



Green Wave Traffic Optimization - A Survey

Warberg, Andreas; Larsen, Jesper; Jørgensen, Rene Munk

Publication date:
2008

Document Version
Publisher's PDF, also known as Version of record

[Link back to DTU Orbit](#)

Citation (APA):

Warberg, A., Larsen, J., & Jørgensen, R. M. (2008). Green Wave Traffic Optimization - A Survey. Informatics and Mathematical Modelling. (D T U Compute. Technical Report; No. 2008-01).

DTU Library

Technical Information Center of Denmark

General rights

Copyright and moral rights for the publications made accessible in the public portal are retained by the authors and/or other copyright owners and it is a condition of accessing publications that users recognise and abide by the legal requirements associated with these rights.

- Users may download and print one copy of any publication from the public portal for the purpose of private study or research.
- You may not further distribute the material or use it for any profit-making activity or commercial gain
- You may freely distribute the URL identifying the publication in the public portal

If you believe that this document breaches copyright please contact us providing details, and we will remove access to the work immediately and investigate your claim.

Green Wave Traffic Optimization – A Survey

Andreas Warberg*
Jesper Larsen†
Rene Munk Jørgensen*

February 8, 2008

Abstract

The objective of this survey is to cover the research in the area of adaptive traffic control with emphasis on the applied optimization methods.

The problem of optimizing traffic signals can be viewed in various ways, depending on political, economic and ecological goals. The survey highlights some important conflicts, which support the notion that traffic signal optimization is a multi-objective problem, and relates this to the most common measures of effectiveness.

A distinction can be made between classical systems, which operate with a common cycle time, and the more flexible, phase-based, approach, which is shown to be more suitable for adaptive traffic control. To support this claim three adaptive systems, which use alternatives to the classical optimization procedures, are described in detail.

1 Introduction

Road traffic is an essential part of modern society and has put a high demand on road networks. Figures from a recent study from the Danish Ministry of Transport (see Danish Ministry of Traffic (2008)) show traffic has increased by 50% since the 80's and that cars and busses are responsible for more than 90% of all transport of people in Denmark (totalling 68 million kilometres).

Traffic network congestion causes delays which add substantial costs to society and businesses on a daily basis and also increase emissions and the risk of accidents. The study mentioned above reports that in 2002 people were spending 100,000 hours in total in queues in the Greater Copenhagen road infrastructure, this corresponds to an economic loss of more than 750 million Euros.

To alleviate congestion, public transport can be improved or the infrastructure can be expanded. In urban areas, the latter is often impossible due to residential areas adjacent to the existing roads. A more subtle way to improve the network performance is to make better use of the existing roads, which can be achieved in part by proper setting of traffic signal parameters.

*Department of Transport, Building 115, Technical University of Denmark, 2800 Kgs. Lyngby, Denmark

†Corresponding author. Department of Informatics and Mathematical Modelling, Building 305, Technical University of Denmark, 2800 Kgs. Lyngby, Denmark, email: jla@imm.dtu.dk

It is estimated that the proper use of intelligent traffic systems including intelligent traffic signals, could increase the capacity of the road network in the Greater Copenhagen area by 5 to 10%.

The literature has many suggestions for the intelligent setting of traffic signals, ranging from purely statistically based methods developed in the early 60's, over actuated traffic signals, to highly adaptive and cooperative methods, which can be realized using actual flow information supplied by traffic detectors. This paper gives a survey of the literature with special emphasis on adaptive methods which attempt to coordinate traffic signals in larger networks so as to optimize some network-wide performance index such as number of stops or delays.

The paper is structured as follows. Initially the most important definitions are presented in section 2, followed by section 3 that describes the measurement of performance for an intelligent traffic signal, and section 4 defining the mathematical model to describe the entire setup. The next three sections review the different traffic signal types and the underlying optimization models. Section 8 describes the adaptive and cooperative systems that define the current state-of-the-art. Finally in section 9 we summarize the findings and make with recommendations for future work.

2 Definitions and setup

Fortunately, the terms of traffic signal optimization seem to be fairly standardized and most articles share terminology.

The traffic network is modelled as a directed graph $G(V, E)$ where V is the set of intersections controlled by a traffic signal and E is the set of roads connecting the intersections. A path is thus a route through the network.

In the context of adaptive traffic control an *artery* defines a main-path, the major road, through a traffic network. Such an artery will generally face higher demand than minor roads adjoining the artery. The time it takes for a traffic signal to get from the start of the green light through the yellow and red and until it again becomes green is denoted the *cycle time*. The cycle time is one of the most important variables in setting up the traffic signal.

A phase (or stage) corresponds to a particular state of the red and green lights of the traffic lights in an intersection. For instance there may be a green phase in the north and south direction for a two-way intersection (which implies red phase in the east-west direction). When a *phase* is mentioned, it is usually implicit that it is the green phase.

The performance is evaluated by considering the *Measure Of Effectiveness* (MOE). Most common is the average delay, but the travel time through the network and number of stops, or some combination of these, is also common.

3 Defining Performance

Essential parameters to the performance of a signalized intersection – or network of intersections – are cycle time, green split and the offset related to the common cycle time.

The amount of consecutive green time, which can be distributed to the phases of an intersection depends on the cycle time. This is why the cycle time is very important to the chosen MOE. In Sun et al. (2003) Sun et al. explain that

[...] minimizing delay leads to short cycle length while minimizing stops indicates long cycle length.

The reason is that a long cycle length may stop a whole group of vehicles (also known as a platoon) and incur a large delay for them, but the platoon of vehicles only experience a single stop. With short cycle time the vehicles never have to wait long for a green light but are on average stopped more frequently.

The cycle time of an intersection is one of the most important parameters in a signal plan since it sets lower and upper bounds on the green times for the phases. This relates to the MOE as well as the safety of a network since 1) if a red light is shown for too long some motorists may start to ignore the signals and 2) if the signals cycle too frequently there is an increased risk of collisions.

The green split, which is the green-time to cycle-time ratio for the phases of the intersection, should be considered as an indication of the amount of traffic expected from each road facing the intersection. Major roads will be given the larger split and minor roads a smaller split.

The offset for an intersection is used to accommodate green waves for traffic travelling from intersection to intersection at a specified pace. This parameter is mostly relevant when optimizing signal plans for major-minor types of arterials where platoons travel (mostly) along a path, which traverses a string of intersections. Some of the most promising results for this specific type of optimization are from MAXBAND and MULTIBAND, described in Gartner and Stamatiadis (2002).

Almost all methods optimize some or all of these three parameters. A less commonly optimized parameter is the *phase sequence* ie. the order in which phases should be green during a cycle. This is mostly relevant when prioritizing certain types of traffic, eg. public transport (see Bretherton et al. (2004)) or emergency vehicles, but also when considering safety aspects.

The problem of choosing an MOE depends on, among other things:

- The type of traffic which should gain benefits: private and commercial vehicles, public transportation, pedestrians and cyclists.
- The network: highway, rural, urban.
- Political objectives: safety, priority to businesses, reduction of emissions combined with more public transportation and *green* buses, which run on alternative fuels.

Clearly there are conflicts of interest among this selection of objectives. One example has already been mentioned. Other examples of objective conflicts are:

- Minimizing delays for vehicles along an artery will cause longer waiting times for crossing pedestrians.
- Prioritizing eg. public transport by skipping a phase will lower the performance for private transport.

In the SCOOT system (see Bretherton et al. (2004)) a phase skipping approach to bus prioritization was implemented and tested in a London intersection. The buses enjoyed 4 sec less delay but the delay for non-bus vehicles increased by 1 sec in total on average. The vehicles on the roads with no bus traffic suffered up to 14 sec delay on average, however.

- Any optimization which improves the experience of traversing the network by vehicle will probably cause more traffic and thus increase emissions.

Most of the articles in the survey use the average delay as an objective. The TRANSYT optimization package by Robertson (1969) uses the performance index (same as MOE) as explained in Ceylan (2006):

The performance index is defined as the sum for all signal-controlled traffic streams of a weighted linear combination of estimated delay and number of stops per unit of time and is used to measure the overall cost of traffic congestion associated with the traffic control plan.

Thus TRANSYT faces the multi-objectivity but the weights must be defined and maintained by the traffic engineers supervising the system. This is not a trivial task and requires intimate knowledge of the network as well as the optimization package. The TRANSYT manual suggests that weights should be set so that 1 stop \simeq 20 sec delay. This is in line with the guidelines used by the Danish Road Directorate (DRD).

In Sun et al. (2003) a true multi-objective optimization approach is tested. Sun et al. use a Non-dominated Sorting Genetic Algorithm (NSGA II) to find Pareto-optimal solutions for the minimization objectives *average delay* and *number of stops* per unit of time.

4 The Optimization Problem

In this section an example of a classical mathematical model for offline optimization will be presented along with a model, which allows for more dynamic systems. The objective function used in an offline optimizer does not consider multi-objectivity but could be replaced by a more refined performance measure. Notation is given in Table 1

$n \in \{1, \dots, N\}$	Intersection indexes
$p \in \{1, \dots, P_n\}$	Indexes of phases at intersection n
Ψ	A set of signal timing settings
C_n	Cycle time for intersection n
θ_n	Offset of intersection n
ϕ_{np}	Phase p green time for intersection n
I_{np}	Interstage (lost) time from the end of phase p until the next
$l \in \{1, \dots, L\}$	Link indexes
$q_l \in \mathbf{q}^*(\Psi)$	User equilibrium link flows given signal timing parameters
$t_l(\Psi, \mathbf{q}^*(\Psi))$	Travel time on link l considering signal timings and user response

Table 1: Notation for the traffic signal and network model part

A classical model

The problem is formulated as the minimization of a MOE in terms of a set of signal settings, Ψ , and a network of user equilibrium link flows (see section 6.2), $\mathbf{q}^*(\Psi)$, which is dependent on the signal settings.

Teklu Teklu et al. (2007) presents a model which is typical for offline optimizers, which is given here with slight modifications:

$$\min \quad TT(\Psi, \mathbf{q}^*(\Psi)) = \sum_{l=1}^L q_l \cdot t_l(\Psi, \mathbf{q}^*(\Psi)) \quad (1)$$

$$\text{subject to : } C_{min,n} \leq C_n \leq C_{max,n} \quad (2)$$

$$0 \leq \theta_n \leq C_n - 1 \quad \forall n \quad (3)$$

$$\phi_{min,np} \leq \phi_{np} \leq \phi_{max,np} \quad \forall n, p \quad (4)$$

$$C_n = \sum_{p=1}^{P_n} (\phi_{np} + I_{np}) \quad \forall n \quad (5)$$

In Teklu et al. (2007) the chosen MOE is the travel time defined as the sum of flow multiplied by travel time on each link and $\Psi = \{C, \theta, \phi\}$. The user equilibrium flows are calculated using a variational inequality, which is not reprinted here considering the scope of the survey.

The sum of green and lost time for all phases of an intersection must equal the cycle time as seen in equation (5). Equations (2) and (4) are safeguards entered by traffic engineers to avoid extreme plans such as the total suppression of green time for a minor road or very high cycle times (capacity), which would otherwise be chosen under congestion. Equation (3) adjusts the offsets so as to create green waves but is only relevant in the common cycle time model, which is a special case of the presented model when $\forall n : C_n = C$. Offset is always considered as a modulus of a *common* cycle time and thus no coordination can be made (in this model) if all intersections run on their own clock.

In addition to this deficiency, this model does not consider phase sequences. Phases are simply enumerated and allocated green time - the order is assumed given.

A dynamic model

In a general discrete time model, time is indexed by $t \in H = \{t_{min}, \dots, t_{max}\}$ and thus H indicates the horizon of the optimization. Ramanathan et al. (1995) contains an example of a general continuous model, which has similarities to the model that will be presented in this section. Each signal is designated a phase for each time unit. Thus the concept of a cycle becomes virtual as it is no longer mandatory for calculating eg. the length of phases given the green splits.

Without a common cycle time - or individual cycle time, even - the offset parameter also disappears. However they can be introduced virtually, in terms of a virtual cycle, and can thus be manipulated to exhibit the same behaviour. The main problem is during initialization when the system has just started. In this case it is possible to synchronize intersections by delaying start-up for those that would otherwise have a positive offset. The same strategy can be used when changing the (virtual) cycle time for the arterial. As discussed in the previous chapter, the common cycle time and offsets requires a periodicity, which is restrictive, and thus the inclusion of these concepts into a dynamic model will not be discussed further.

Phase sequences and green splits are unified by the specification of the phase in a timeslot, t , referred to as $p_n(t)$. For each intersection there will be a fixed number of

phases, P_n , which are free from right-of-way conflicts. For a simple cross intersection with left-hand drive vehicles (see Figure 1) this number is 2: straight, left, and right turning flows in north and south directions for phase 1 and in east and west directions for phase 2.

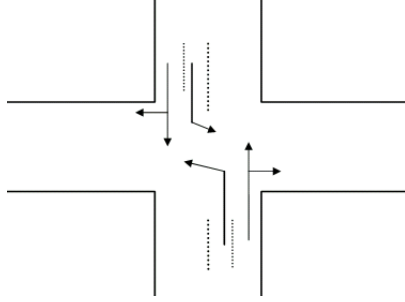

Figure 1: Simple 2-phase intersection

Thus a specific phase $p = p_n(t) \in \{1, \dots, P_n\}$ is selected for each timeslot. With this definition the green splits are implicit in the phase sequence and we have $\Psi = \{\mathbf{p}\}$.

In the following, some constraints will be defined to show that the dynamic model is capable of satisfying constraints such as the ones for the classical model. Initially the set of consecutive timeslots allocated to phase p for intersection n is defined:

$$T_{pn} = \bigcup_{T=\{t_1, \dots, t_2\}} \text{st. } p \notin \{p_n(\min T - 1), p_n(\max T + 1)\} \wedge \forall t \in T : p_n(t) = p \quad (6)$$

Thus T_{pn} is a set of sets, each containing a consecutive number of time units which bounds the extent of a particular phase.

Satisfaction of minimum and maximum green times is the most common constraint, usually defined within a cycle. In the dynamic model this constraint is formulated so that the minimum and maximum green times must be respected over the entire horizon in the following equation:

$$\forall p, n : T_{min, pn} \leq \underline{|T_{pn}|} \wedge \overline{|T_{pn}|} \leq T_{max, pn} \quad (7)$$

The operators $\underline{|\cdot|}$ and $\overline{|\cdot|}$ are used to extract the smallest and largest sets (cardinality) from T .

That is, the length of all consecutive series of time slots in which phase p is run, must satisfy the selected minimum and maximum green times. This constraint only demands that no phases are given too little or too much time. It is also necessary to ensure that phases are given green time in some minimum and maximum proportion to the other phases of the intersection.

$$\forall p, n : R_{min, pn} \leq \frac{\sum |T_{pn}|}{|H|} \leq R_{max, pn} \quad (8)$$

Where $|H|$ is the number of time steps in the signal timing plan so far and $R_{min, pn}$ and $R_{max, pn}$ are the minimum and maximum ratios of time over the optimization

horizon, which is allowed for phase p at intersection n . It is clear that $\forall n : \sum_{p=1}^{P_n} \frac{|T_{pn}|}{|H|} = 1$ due to the definition of the phase specification function, $p_n(t)$, ie. in each time slot a signal controlled intersection is assigned to a particular phase.

Considering the north-south direction (phase 1) of figure 1 to lie along an arterial and the east-west direction (phase 2) being a minor road, the min and max ratios could be set as in Table 2.

p	$R_{min,p}$	$R_{max,p}$
1	0.6	0.8
2	0.2	0.4

Table 2: Example of minimum and maximum green time ratios for a simple, 2-phase intersection

Equations 7 and 8, along with proper minimum and maximum values, ensure that green time is distributed evenly over the optimization horizon, since equation 8 ensures that the proportions are correct and equation 7 makes sure allocated green time is not bunched together in some narrow part of the horizon.

These specifications result in a model which is relatively easy to represent but may be difficult to fit into the standard mixed-integer programming (MIP) scheme. An alternative is to use a metaheuristic procedure, or the application of a set partitioning model (SPP), for instance with column generation.

5 Types of Traffic Signals

At present there are three major types of traffic signal systems called *pretimed signals*, *actuated signals* and *adaptive signals*. They are the result of incremental improvements described in chronological order below:

Pretimed signals use static plans for phase sequences, cycle time and green splits according to the day of time. They are based on the assumption that demand is fairly stable within certain divisions of time eg. morning, midday and evening or work-day/weekend. For instance, in the morning (7am to 8.30am) and afternoon (15.30pm to 17.00pm) the traffic is usually heavier than during the day or night due to commuters.

Traffic may prove to be more dynamic, though, and therefore the utilization of these signals must be monitored on a regular basis so proper adjustments can be made.

Actuated signals function like pretimed signals but with the ability to *lengthen* the green period by a certain amount, if additional vehicles are observed. To achieve this, the signal needs detector input about the demand it faces for each phase. A major disadvantage due to the autonomous operation is that it becomes impossible to setup green waves since signals start their cycle at arbitrary offsets and are unlikely to share a common cycle time.

Adaptive signals are a network of signals which attempts to optimize some MOE in a manner which is at least as intelligent as for actuated signals.

The key to adaptive signals is reliable detection and short term prediction of traffic. Adaptive signals must be able to respond to the dynamic aspects of traffic, which are not captured in the design of pre-timed signal plans. Adaptive signals use historical

input and current detector input to make short term predictions for what is going to happen eg. within the next minute, next 10 minutes and so forth. For this reason, and as stated in Shenoda and Machemehl (2006), adaptive systems are not truly adaptive because they rely on these short term predictions and thus will always lag behind the actual traffic. For short term prediction methods from time series analysis eg. ARIMA models (see eg. Hamed et al. (1995)) can be used to get more accurate predictions.

An isolated adaptive signalized intersection has advantages over actuated signals because it can skip a phase to give priority to a bus, for instance. The main attraction with adaptive signals is when they are set to work together. A good system will naturally cause green waves to appear and move the direction of the green waves along with changes in flow.

6 Milestones of Traffic Signal Optimization

This section will touch briefly upon two results which have been used throughout the field ever since they appeared and continue to be of great importance, even today.

The first result is the two equilibrium principles of traffic flow by Wardrop (1952) and the second result is by Webster, Webster (1958), who gives expressions for optimal cycle time and green splits.

6.1 Delay and Queuing Models

An expression for estimation of the delays incurred at an intersection was given by Webster. The estimate is an approximate formula for isolated intersections with a fixed timing plan under steady state and undersaturated conditions ie. the flow cannot be dynamic and the in-flow must not exceed capacity. Webster uses his delay formula to give expressions for the optimum cycle and green times. Webster's results have been widely used in the literature eg. in Shenoda and Machemehl (2006) to generate initial solutions of cycle length and green splits for a metaheuristic search and in Gartner et al. (1975) to calculate cycle lengths.

Webster's formula, along with other delay formulas developed from queuing theory, suffer because of the assumption of steady state conditions. As the load on the intersection increases it will take longer time to reach stochastic equilibrium Roupail et al. (2001). During the stabilization period the signal settings must remain fixed, which will never be the case in adaptive systems. These types of models are still used, see eg. Mirchandani and Zou (2007) where Mirchandani and Zou develop a FIFO single-server queuing model with Poisson arrivals. A related approach using a stochastic inventory model is seen in Saka et al. (1986).

Time series analysis and other *moving average* techniques can be used to relax these assumptions. In Hamed et al. (1995) an ARIMA process is used to make short term (1 minute) predictions of arrivals. The RHODES system Mirchandani and Head (2001) makes short term predictions on multiple levels of resolution (single-vehicle and platoons). In Shenoda and Machemehl (2006) a Poisson process is used to calculate the inter-arrival time, with the parameter being the mean arrival rate, thus anticipating the dynamic nature of traffic.

6.2 Traffic Assignment

Traffic assignment (also known as flow assignment) is the determination of vehicular flow along origin-destination (OD) paths and, consequently, along links in a traffic network.

Traffic signals are set to accommodate the flow of traffic. Wardrop contributed with two principles, which can be used to determine the equilibrium traffic flow:

1. **User Equilibrium:** (UE) each motorist has minimized his own travel time (greedy route choice)
2. **System Equilibrium:** (SE) the average travel time is minimized (coordinated route choice)

Given the choice, a user will select the route which he *perceives* to be the best. This route does not necessarily correspond with the actual shortest route, which has led to the Stochastic User Equilibrium (SUE) variation Daganzo and Sheffi (1977) where this error is modelled by a stochastic element.

The SUE is the most realistic model since 1) motorists may not have perfect route information and may also choose a longer route on purpose (eg. for the scenery) and 2) motorists, at present, cannot communicate in order to obtain SE. In addition the SE entails that some motorists may not have an optimal route, this kind of sacrifice will be difficult to accept.

Bilevel formulation

In order to perform a traffic assignment for a network, flow data is obtained from traffic counts or detector input over a time period. Auxiliary information such as turning directions and vehicle types are collected as well, if possible. This data is fitted by a stochastic process and the optimization is made on the assumption that the process can describe the actual arrivals. Thus there are two problems 1) determining demand and 2) optimizing the traffic signals accordingly.

It is important to realize that changing the traffic signal settings will cause changes in the flow and that changing the flow should cause the signal settings to be recalculated. This has given rise to a number of papers considering the two problems at the same time in so-called bilevel formulations (also known as the Network Design Problem). Allsop and Charlesworth (1977) presents an iterative procedure which optimizes traffic signals and then solves the traffic assignment problem until mutual consistency (convergence) is achieved, and Chiou (1999) uses a gradient projection method for finding local optima combined with a global heuristic search. The work presented in Ying et al. (2007) is based on sensitivity analysis, and in Teklu et al. (2007); Ceylan and Bell (2004b) the problem is solved using a genetic algorithm approach.

A feature of adaptive systems is that they are less dependent on a large database of historical flow data since they use online data input from detectors, which they are, in turn, more dependent on. Thereby they do not have to consider the problem of mutual equilibrium between signal settings and user equilibrium in the same degree as these *offline* systems.

7 Systems for Offline Optimization

The surveyed articles span the period from the 60's to present. In this section some tendencies for offline optimization systems are surveyed.

Most authors choose to present a mathematical model of the problem, in the spirit of the one presented in section 4, which optimizes for one or more of the parameters mentioned in section 3. Attempts to produce a closed-form solution for the problem are seen often eg. Ramanathan et al. (1995), which presents a general model that has resemblances with the model in section 4.

For representation of network layout, the models are based on either graph theory or some kind of cell transmission scheme or petri net system. The petri net representation is very popular and some examples of its use are Heung et al. (2005), Dotoli et al. (2006) and Dotoli and Fanti (2006).

In a petri representation of a traffic network, spaces on links are represented by cells, which can fit a single vehicle. When a cell is occupied no other vehicle may enter. Vehicles progress through the network by making transitions to adjacent cells. The stop-bars of intersections can be represented in the petri net as a line of cells blocking a link facing the intersection. When the phase begins the stop-bar cells are enabled and vehicles may pass. The petri net representation fits well into the context of traffic networks due to its representation of concurrency (spaces in a lane) and triggered actions (cross on green light).

For the model to be solvable without an external evaluation tool, such as TRANSYT, it must contain functional constraints which relate eg. the proper offset for signals along an arterial to flow-specific parameters such as saturation flow rate and the platoon dispersion factor. The model must also adjust link flows according to the signal settings, that is, the model must be bilevel, as introduced in section 6.2. An example of such a model is seen in Ceylan and Bell (2004a) where a genetic algorithm finds optimal signal timing plans, considering user response to signal changes. TRANSYT is used to obtain a fitness (MOE) value and the Path Flow Estimator for determination of the stochastic user equilibrium.

Considering a typical optimization formulation involving a common cycle time, green splits and offsets, it is clear that - even with some discretization of time - the search space is vast, especially when considering some form of simulation for obtaining the objective value. An example of a heuristic designed to cut down the search space is ADESS (see Ceylan (2006)). Most often the heuristics are embedded into the search routines and operate, for instance, by using "common sense" rules such as pruning short cycle lengths under high saturation or by exploiting sensitivity knowledge of the problem Patriksson (2004). Another way to deal with this issue is to employ a metaheuristic search, which is simply run until a result is needed. Some examples are: Shenoda and Machemehl (2006) (tabu search), Chen and Xu (2006) (particle swarm optimization) and genetic algorithms, which are the most popular metaheuristics, by far see Sanchez et al. (2004), Ceylan and Bell (2004a), II et al. (1992), Takahashi et al. (2002), Sun et al. (2003), Taale and van Zuylen (2004), Ceylan and Bell (2004b), Teklu et al. (2007) and Ceylan (2006).

Systems which operate in this manner are mostly suited to offline use considering that some reported running times are as high as several hours, even for small networks. Some authors eg. Dotoli et al. (2006) turn such a system into an adaptive system by re-running the optimization procedure every K cycle but clearly this strategy is not possible for systems with long run time requirements. Furthermore the next set of

signal timing settings may be quite different from the current one and changing plans in an instant will cause transient sideeffects such as malfunctioning green waves.

Much work focuses on optimizations for single intersections or coordination of signals along an arterial. Gartner et al. (1991) gives a walkthrough of the most promising progression schemes at the time (PASSER-II, NO-STOP-1) and extends the MAXBAND approach from a single-arterial bandwidth optimization into MULTIBAND, which optimizes bandwidth along multiple, possibly intersecting, arterials. Nathan H. Gartner (2004) is an example of the selection and optimization of an arterial - or priority route - with subsequent network-wide optimization, taking the arterial optimization as a constraint. In the article Heydecker (1996) Heydecker propose how to use existing optimization methods for single intersections in combination to achieve a network optimization. Though Heydecker admits that, because of the decentralization, it will be difficult to obtain coordination.

8 Adaptive & Cooperative Systems

Adaptive traffic control systems aim to coordinate signal controlled intersections so as to optimize some performance index eg. average delay or number of stops (or a combination) but also to reduce the need for constant supervision and tuning of intersections.

They do this by dynamically adjusting cycle times, phase sequences and green splits according to traffic detected as well as the predicted traffic, thereby reacting to those dynamic aspects of traffic, which cannot be captured by the static optimization routines used to generate time-of-day plans. Some authors (Shenoda and Machemehl (2006), Mirchandani and Head (2001), Gartner et al. (1995), Bretherton et al. (2004)) even skip or work around the conventional periodic scheme based on a common cycle time and make direct assignments of phases and allow phases to be skipped, as presented in section 4.

It is evident that the cycle time is crucial in optimization because, for a congested network, increasing the cycle time will always cause a throughput increase (there are always cars waiting to cross the intersection). In the literature the cycle time is often common to all intersections under traffic control so that green waves (arterial progression) can be produced. For direct assignment systems the throughput is dependent on allocation to phases of consecutive green time. Long cycle times lead to long phase durations, which allow a steady flow of vehicles to pass and minimize lost and interphase time per time unit.

For large networks the enforcement of a common cycle time is inappropriate, however. Consider a network which is so large that two disjoint arterials exist. In this case it is unlikely that a common cycle time will allow green waves to exist for both arterials. For networks of this type (size) a direct phase assignment model might provide the necessary flexibility. Another feature of considering very large networks is the possibility of traffic redirection. If it is detected - or predicted - that an arterial is, or will be, congested under current flow conditions it is sensible to redirect some traffic onto alternative routes.

In this section some in-depth discussions are given for three adaptive systems, which do not rely on offline optimization as it was presented in section 7. The systems are:

1. **RHODES** by Pitu Mirchandani and Larry Head presented in Mirchandani and Head (2001) - a hierarchical system for network-wide optimization.

2. A **Phase-by-Phase** optimization strategy by Michael Shenoda and Randy Machemehl presented in Shenoda and Machemehl (2006) - a system using the metaheuristic tabu search for determining greens for isolated intersections in a phase-by-phase manner.
3. **DOGS** by Danish Technical Traffic Solution (TTS) evaluated in the Danish article Lauritzen (2004), which provides criteria-based capacity increases along an arterial.

The systems will be compared in the areas of *prediction* and *optimization strategy*.

8.1 RHODES

RHODES' approach to traffic signal optimization is a hierarchical one with 3 layers of detail, see Figure 2.

The macroscopic layer performs *dynamic network loading*, which involves observing changes in the aggregated flow data of the entire network due to variations in the OD matrices. This layer supplies estimates of link flows to the middle level in rough numbers eg. vehicles per hour.

The mesoscopic middle layer considers sectors of the network eg. an arterial. This *network flow control* layer works in the detail level of platoons and average speeds. Green time is allocated to phases to accommodate the movements of the platoons and so coordination of intersections is done at this level.

At the lowest level is *intersection control* where vehicles are handled individually (a microscopic layer). Here the green times and phase ordering suggested by the middle layer are fine tuned.

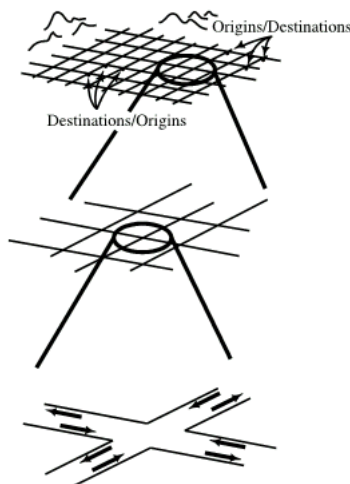

Figure 2: The three levels of detail: network, sector, and intersection

An adaptive traffic control system must operate quickly in order to adapt signals to traffic in real-time. The RHODES platform has good decomposition opportunities and is pluggable ie. the upper level is a black box feeding the lower level with predictions and optimizations. At the time the article was written, the top level of RHODES had

not received much development and thus only the middle and lower level are described herein.

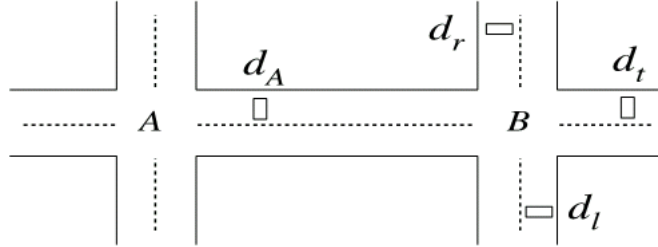

Figure 3: Propagation of information in a simple grid

Prediction

The PREDICT method Head (1995) by the co-author, Larry Head, is used to make predictions for individual vehicles. PREDICT is built for network prediction and relies on the fact that incoming flow to an intersection originates from adjacent intersections. This concept can be explained from Figure 3 where traffic detected at d_a is the sum of right-turning traffic at detector d_r , left turning traffic at d_l and through-going traffic at d_t .

Thus, given flow estimates for the links facing intersection B, and turning probabilities for each link, an estimate can be given for the inflow to intersection A from east. On the link between the two intersections there will be traffic entering and exiting the system, but these contributions - and losses - to the traffic, which can be measured at d_a , are expected to be very small.

Prediction of arrival times of the vehicles which have passed detectors $d_{\{r,t,l\}}$ depend on the current phase at intersection B and queue conditions. Mirchandani and Head have identified four cases, which cover arrivals at an intersection, which are summarized in table 3.

	Green	Red
No queue	0	T_G
Queue	T_Q	$T_G + T_Q$

Table 3: Delay incurred for a vehicle arriving to an intersection in various states where T_Q is the time for ahead queue to clear and T_G is the time to the next green.

In the cases involving queue there is, of course, a possibility that the vehicle will not be able to cross the intersection before several green phases have occurred. This is likely to happen under high congestion when intersections are placed close together.

At the mesoscopic level, network flow control, the APRES-NET prediction method, is used. It is based on simulation and has similarities to PREDICT, though it works in the detail level of platoons and encompasses several intersections, not just the upstream ones but also those upstream of the upstream intersections and so on. Since the 2nd level must deliver complete suggestions for timing plans for each intersection (to be fine tuned by intersection control) it must run quickly. Performance is dependent on

the number of intersections in the monitored sector, and sector sizes can thus be scaled to match the speed requirements depending on hardware.

The prediction horizon for network flow control is 200-300 seconds. Cycle times for simple intersections with just a couple of phases vary between 60 and 150 seconds so this horizon is adequate to predict and respond to most types of fluctuations by performing phase skipping, phase reordering and assignment of phase durations. The intersection level control operates with a prediction horizon of 20-40 seconds and thus can only make decisions on whether to lengthen or decrease the green time of phases within that horizon.

Optimization

As in the dynamic model of section 4, timing plans are described by phase ordering and duration independent of cycle time, splits and offsets. Optimization is performed on each level using prediction results for that level.

At the network flow control level the REALBAND algorithm forms progression bands (ie. *green waves*) for platoons traversing the sector based on the predictions from APRES-NET. This is done by finding *conflicts* between platoons, which will request access for conflicting phases at the same time. In this way a conflict can be regarded as the denial of green to a platoon due to the passage of another platoon. A decision tree within the optimization horizon of 200-300 seconds is build and explored to find the configuration with the fewest conflicts. This results in a set of phase orderings and green times for each intersection.

At the lower level a dynamic programming approach, COP, takes the results from REALBAND and distributes green time for some horizon to the phases received from the above level. The phases and their ordering must be respected so as to not introduce conflicts which have been resolved by REALBAND. For the same reason there are restrictions for the maximum change in either direction of the given green times, but COP is allowed to use its more detailed predictions to perform the above fine-tuning of green times.

Evaluation

RHODES has been implemented and evaluated in CORSIM as part of the evaluation for the Federal Highway Administration (FHWA) inclusion in RT-TRACS. RT-TRACS is an effort to choose and standardize a peak performance traffic signal optimization system for American traffic networks.

The simulation is done for an arterial of 9 intersections with steady increase and then decrease of traffic over a 2-hour period. This is a FHWA test case and the baseline traffic control system is semi-actuated control based on the results of offline tools including TRANSYT and PASSER, which represent the best-can-do from an offline approach and can be considered a hard competitor.

Testing shows that RHODES is more capable of exploiting the capacity of the arterial. As long as there is no congestion the throughput will match the demand and in the comparison RHODES can simply take more load before experiencing congestion.

Real adaptive systems should excel in the case of low demand, since the overcapacity will then allow RHODES to, roughly said, cater for each vehicle. The effect, compared to the semi-actuated control, is convincing with 50% reduction in delays for low demand and 30% reduction for high demand. This effect is expected to disappear when demand

reaches the capacity of the arterial in which case, for both systems in the comparison, throughput can only be improved by increasing the green time along the arterial and maintaining proper coordination.

The simulation was run multiple times and for both throughput and delay it is clear that RHODES is more consistent than semi-actuated control and offers less variability from run to run.

8.2 Phase-by-Phase

The phase-by-phase (PP) system was developed to overcome a number of deficiencies, which seemed widespread in adaptive systems:

- Fixed cycle length and/or fixed step for variation of cycle length
- Utilization of aggregated demand data only
- Fixed coordination of signals along an arterial and through a network

The proposed overall scheme to improve upon these issues is the isolated optimization of intersections and more fine-grained tracking of vehicles.

The optimization process has been made independent from determination of the network state, ie. detection and prediction, and as such some of these subjects are mostly discussions and proposals for improvements.

Prediction

In the proposed form the PP system uses a Poisson process to generate interarrival times. Alternatives are some form of time-series analysis or a Poisson process with variable mean. The use of detections made upstream could also be used, such as it is in RHODES. The performance of PP is highly dependent on the ability of the chosen prediction system to generate proper forecasts but, as will be seen in the test results, the potential benefits are great.

Optimization

The optimization procedure of PP seeks to minimize the stopped delay using input from the prediction process. The most widely used measure of effectiveness is stopped delay (see eg. Gartner et al. (1991), Mirchandani and Zou (2007) and Taale and van Zuylen (2004)) but the authors show that there is also a linear relationship to total travel time.

H should be in the order of the desired cycle time and λ_k give the green splits and thus we have a full plan for the signal. Stopped delay can be calculated from this plan and the predicted arrivals. In Figure 4 this idea is outlined.

In equation (9) the rules for stopped delay are extracted when vehicle j arrives on approach i at t_{ij} .

$$delay = \begin{cases} cs + H \cdot \lambda_{k_{i-1}} - t_{ij} & \text{when } t_{ij} \leq cs + H \cdot \lambda_{k_{i-1}} \text{ (before green)} \\ cs + H - t_{ij} & \text{when } t_{ij} \geq cs + H \cdot \lambda_{k_i} \text{ (after green)} \\ 0 & \text{otherwise} \end{cases} \quad (9)$$

H	Horizon of optimization
cs	Cycle start time
$ce = cs + H$	Cycle end time
$i = 1, \dots, N$	Approach indexes
$k = 1, \dots, M$	Phase indexes
λ_k	Is a partitioning of H into phases and $0 = \lambda_0 < \lambda_{k-1} \leq \lambda_k \leq 1$
λ_{k_i}	The time into H before the phase k , involving approach i , ends
j	Vehicle id for predicted vehicle arrival within the horizon
$t_{i,j}$	The arrival time for vehicle j on approach i

Table 4: Notation

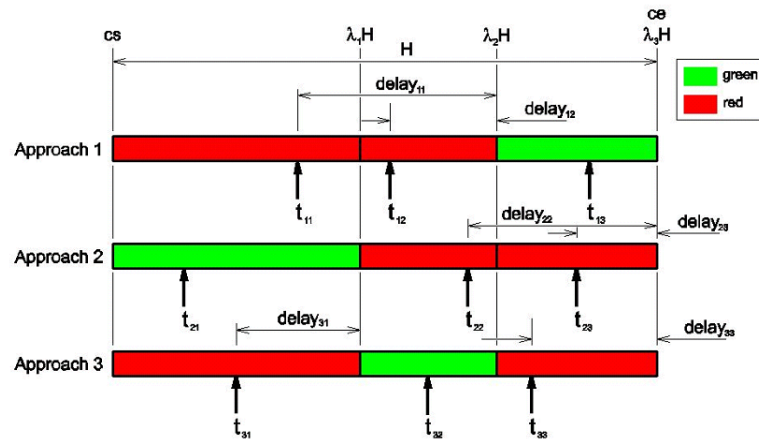

Figure 4: Calculation of stopped delay in the Phase-by-Phase system for an intersection with 3 approaches and 1 exit (no turning movements).

In the second case of equation 9, vehicles incur stopped delay since they arrive after their approach has been served green time in the planning horizon. Thus they will not be served before the next green, which has not yet been planned, and stopped delay is accumulated until then. This is called carryover since vehicles are carried over into the next cycle.

PP also takes into account queue start-up delay and thus covers the most critical sources of delay. However PP makes the assumption that granting green time to a phase will cause the approaches to be cleared completely ie. no vehicles must experience more than one green phase before they can leave.

The objective function is defined using these delay terms and thus optimization can be done by making changes in the λ_k -values within some critical points in the horizon. Looking at Figure 4 it is seen that approach 2 is served green time until $\lambda_1 H$, suppressing green from approach 1 and 3, which both have arrivals. By switching phase immediately after t_{21} (setting $\lambda_1 = (t_{21} - cs)/H$) approach 1 could receive green until immediately after t_{12} and so on. This example involves switching of the phase order, which was not considered in the paper.

In the PP paper Shenoda and Machemehl (2006) a solution method using the above scheme is presented as a combinatorial problem. But the number of combinations increases exponentially with the number of arrivals and the number of phases. Therefore

a tabu search is employed. Webster's formula for optimum green time splits is used in the Proportional Heuristic to obtain a good initial solution and a 1-bit neighbourhood function is defined by making changes to a single value in λ_k (a low influence move), preserving the phase order. Candidates for the step of these changes range from the transmission time of an electronic signal ($\approx 10^{-3}$ sec) to the minimum headway between two vehicles travelling in a platoon (≈ 2 sec cf. Greenshields et al. 1947). A high influence move, which reorders phases, is also described but is not included, as mentioned.

Evaluation

Shenoda and Machemel compare the results of their metaheuristic search to pretimed and actuated signal control settings obtained from the CORSIM microsimulator using a 4-phase cross intersection.

The intersection was subjected to 8 different data sets of arrival times. In Figure 5 the stopped delays for the PP system are compared to the simulation results using pretimed plans and standard traffic actuated control.

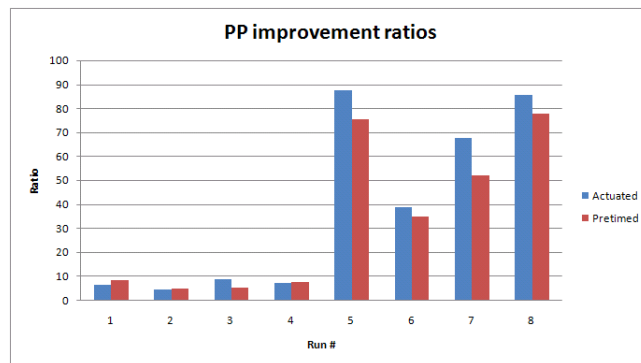

Figure 5: Improvement factors of PP compared to pretimed and actuated control in the 4-phase intersection

The results should only be taken as indications since a number of assumptions were made for PP that the prediction algorithm supplied perfect information. In addition the actuated control was only semi-actuated since detectors were only used in one direction, the other being timed as in the pretimed case, which was optimized using Webster's formulas.

In spite of these issues it is interesting to observe that the (semi-)actuated control strategy is not always superior to pretimed plans. It is clear, however, that both strategies are outperformed by PP. Under the given assumptions - in particular that concerning accuracy of predictions - PP can be used to establish a baseline for the best possible performance. This becomes even more true when the phase ordering constraint is dropped allowing reordering and skipping of phases.

Unfortunately Shenoda and Machemehl do not test PP on a network or even along an arterial. The optimization procedure does not consider coordination in itself though it is proposed that the prediction routine should consider departures from adjacent intersections, such as the method by Head employed in RHODES. It is speculated that such propagation of departure information could give rise to some coordination, depending on the horizon of optimization.

8.3 DOGS

DOGS is an extension of the DOG system. The first 3 letters can be directly translated from Danish to *dynamic optimization of greens* and the appended S means *coordination*. Thus DOG is a traffic-actuated optimizer for single intersections, as described in section 5, and DOGS adds coordination. The DRD has implemented DOGS along several arterials in Denmark.

DOGS is a criteria-based system which relies on a common cycle time for coordination. The intended area of application is traffic signals along arterials, which see a high fluctuation in demand.

The purpose of DOGS is to increase the capacity of the arterial in high demand periods and revert to offline-optimized, pretimed plans in low traffic situations. The capacity increase is realized by increasing the common cycle time and allocating the extra green time per cycle to the phases along the arterial. This will cause increased delays for the minor roads, but may prevent queues from reaching the previous intersection, or even prevent queues in cases of light congestion. DOGS is also capable of providing priority to buses by extending the green time when buses are near an intersection.

At present the system must be tailored to the environment in which it operates. For this reason the following sections will use the Herlev area in Denmark as a reference area in order to explain certain concepts. Figure 6 shows the layout of this network.

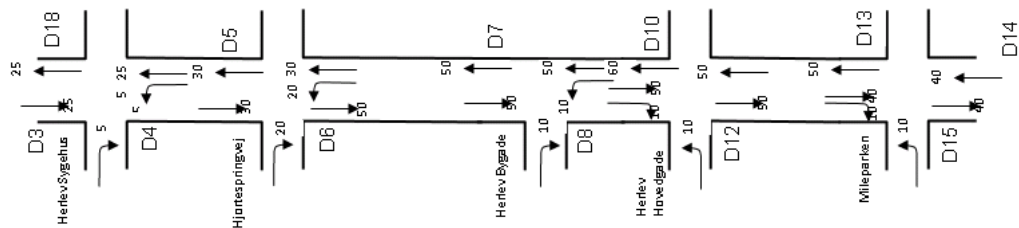

Figure 6: Layout of the O3 arterial in Herlev which is under DOGS control. The arrows and numbers indicate flow direction and examples of typical vehicle count.

Prediction

DOGS is a purely traffic-actuated system and no prediction is used when the system is activated due to heavy traffic conditions. In spite of the intended flexibility of the system this is a point which puts high demand on the implementing traffic engineers since traffic through the arterial must be assessed manually when the system is put into production as well as during maintenance.

An alleviating point to the lack of prediction is the fact that the current arterials under DOGS control are relatively small, and static predictions can be made by an experienced traffic engineer. Furthermore, since DOGS only operates under high load conditions, predictions become less valuable - or superfluous, even - because all that can be said about the arterial in this case is that it is heavily loaded with traffic.

Optimization

Since DOGS only kicks in under congested or near-congested conditions (for the Herlev area when the load exceeds 60%) it is simple to optimize the throughput since any increase in green time will just allow more vehicles to pass (the phase is never emptied of vehicles).

That DOGS only operates during high-congestion levels is an unusual trait for an adaptive system since they usually excel in optimization under *normal* ie. uncongested load conditions (see the comparison of RHODES and a semi-actuated system in section 8.1). This can be explained by the lack of an explicitly defined objective function and optimization routine.

The objective is to keep the load degree (load/capacity) for the most heavily loaded intersection below 90%. To do this the common cycle time and green times are set according to the load level. The adjustments are made with a few seconds per cycle to avoid sudden, major changes in cycle time and temporary loss of coordination.

Coordination is achieved by running the signals on a common cycle time, but offsets are not adjusted when the common cycle time changes, so this issue should receive further investigation.

A set of non-overlapping criteria are used to select a program with the appropriate capacity for the detected inflow. For a technical description of these criteria cf. Warberg (2007)

Evaluation

Tests have shown that the system is indeed capable of increasing the capacity, with reduced queue lengths as a result. When the arterial in Herlev is at or above moderate load, DOGS will increase the capacity by 15-25% compared to the capacity if only the pretimed plans were in use.

8.4 Comparison

The three systems presented here have different scope and as such cannot be compared directly. The RHODES system is the most general, being prepared for network-wide optimization, though it will perform well along an arterial, as shown in the FHWA test case. The DOGS system is specifically designed to increase capacity along an arterial. It is very flexible but requires many input parameters, for which there is no clear selection strategy. Finally the phase-by-phase system performs advanced intersection control but had no inherent strategy for coordination at the time this article was written.

Some comparisons can be made in the two main topics covered for each system ie. *prediction* and *optimization*.

Prediction

In this area RHODES is by far the most advanced system. The systems used at intersection and sector level control and in the detailed level and scope are similar and build on existing work. Predictions are made from detector data from upstream intersections using turning probabilities and speeds, which can be extracted from historical data.

At the time of writing, the Phase-by-Phase system had "perfect" prediction ie. the prediction process was directly linked to the traffic generation process of the simulator. The recommendation from Shenoda and Machelme is to further investigate the ARIMA time-series analysis framework to obtain accurate prediction for arrivals, which they argue is of dynamic nature.

DOGS has no prediction capabilities. On the Herlev implementation there is a general assumption that traffic which enters the arterial at either end is assumed to pass through the arterial. Turn-in and turn-out movements are thus expected to cancel out. This assumption could prove to be cumbersome if DOGS was to operate on longer arterials with differing traffic patterns in different regions.

Optimization

DOGS has a clear advantage in optimization since, for each cycle, the only decision to be made is whether to switch between traffic-actuated control and pretimed signal plans or to change to a lower or higher capacity program. This can be done in constant time using constraints such as the one presented earlier. DOGS has no explicitly stated objective function, only a *political* objective - capacity increase with reduced service for minor roads, which can be assessed in rough terms using video detectors.

Phase-by-Phase minimizes delay using tabu search by adjusting green time proportions assigned to phases. The initial solution is obtained from a proportional heuristic, using Webster's results, and the 1-bit neighbourhood function redistributes the green time for one single phase to the next. The running time of the search algorithm can be set to the maximum time before a decision must be implemented eg. until the end of the current phase.

RHODES optimization in the middle level involves generation and traversal of a conflict resolution tree in order to find the best path ie. conflict resolution according to some MOE. The optimization is made for predictions of traffic 200-300 seconds in the future. The article on RHODES does not mention how often the middle level optimization is performed, though it seems natural to reoptimize every time new predictions become available or continuously, if they are updated before the optimization completes. The conflict resolution timing plans are fed to the intersection level optimization, which fine tunes the plans according to predicted arrival of individual vehicles using a dynamic programming approach. The optimization is valid for 45-60 seconds into the future and is rerun at the end of each phase.

9 Conclusion

The emphasis of this survey has been on adaptive systems, which can accommodate for the fluctuations in traffic. The flexibility of the model (or lack of it) underlying the optimization is a determining factor regarding the level of adaptiveness that is achievable. The offline optimization systems (section 7) all operate with the common cycle time concept, which allows coordination to be set up by offsetting downstream intersections. The common cycle time is prohibitive when adaptive systems try to react to (predicted) arrival of single vehicles or platoons of vehicles, even.

There are several models for traffic networks, which are not based on the periodic behaviour of offline systems to perform coordination. Instead they assign green time to phases in some order, which is optimal given the detected and predicted traffic.

In section 8 three systems were discussed in detail. They were selected to give examples of adaptive control at different levels (network, arterial and intersection). Two of them (network and intersection control) use the direct assignment / phase assignment methodology and the last (DOGS for arterial control) operates with a classical model, but is designed so that the mentioned problems are negligible.

DOGS is an example of a simple, but efficient, solution to dynamic capacity adjustment for an arterial. It has been implemented for multiple highway arterials and has thus proven that it can supply capacity increases when needed as well as adjust priority to minor roads once the traffic flow on the arterial diminishes. DOGS has little mathematical background, however, and has not been simulated prior to implementation. In a future project it would be interesting to introduce a mathematical foundation for DOGS, preferably on the basis on some established arterial progression scheme such as REALBAND. Before and after scenarios could be simulated to determine, what improvements are possible by going from a system adjusted by ad-hoc methods to a truly optimized system.

Acknowledgement

The authors would like to thank Lars Bo Frederiksen and Nicolai Ryding Hoegh of the Centre for Traffic Copenhagen, and Steen Merlach Lauritzen at the Danish Road Directorate for valuable information on real-life applications and system setup.

References

- R.E. Allsop and J.A. Charlesworth. Traffic in a signal-controlled road network: An example of different signal timings inducing different routeings. *Traffic Eng Control*, 18(5):262 – 265, 1977.
- D. Bretherton, M. Bodger, and N. Baber. Scoot - the future [urban traffic control]. *Road Transport Information and Control, 2004. RTIC 2004. 12th IEE International Conference on*, pages 301 – 306, 2004.
- H. Ceylan and M.G.H. Bell. Traffic signal timing optimisation based on genetic algorithm approach, including drivers' routing. *Transportation Research Part B*, 38:329 – 342, 2004a.
- Halim Ceylan. Developing combined genetic algorithm - hill-climbing optimization method for area traffic control. *Journal of Transportation Engineering*, 132(8):663 – 671, 2006.
- Halim Ceylan and Michael G.H. Bell. Genetic algorithm solution for the stochastic equilibrium transportation networks under congestion. *Transportation Research Part B*, 39:169 – 185, 2004b.
- Juan Chen and Lihong Xu. Road-junction traffic signal timing optimization by an adaptive particle swarm algorithm. *9th International Conference on Control, Automation, Robotics and Vision, 2006, ICARCV '06*, 2006.
- S.W. Chiou. *Optimization of Area Traffic Control for Equilibrium Network Flows*. PhD thesis, University College, London, 1999.
- Carlos F. Daganzo and Yosef Sheffi. On stochastic models of traffic assignment. *Transportation Science*, 11(3):253 – 274, 1977.

- Danish Ministry of Traffic. Denmark's infrastructure 2030, 2008. [in Danish].
- M. Dotoli, M.P. Fanti, and C. Meloni. A signal timing plan formulation for urban traffic control. *Control Engineering Practice*, 14:1297 – 1311, 2006.
- Mariagrazia Dotoli and Maria Pia Fanti. An urban traffic network model via coloured timed petri nets. *Control Engineering Practice*, 14(10):1213 – 1229, 2006.
- Nathan H. Gartner, John D.C. Little, and Henry Gabbay. Optimization of traffic signal settings by mixed-integer linear programming part ii: The network synchronization problem. *Transportation Science*, 9(4):344 – 363, 1975.
- Nathan H. Gartner, Farhad J. Pooran, and Christina M. Andrews. Implementation of the opac adaptive control strategy in a traffic signal network. *IEEE Intelligent Transportation Systems Conference Proceedings*, 1995.
- N.H. Gartner and C. Stamatiadis. Arterial-based control of traffic flow in urban grid networks. *Mathematical and Computer Modelling*, 35:657 – 671, 2002.
- N.H. Gartner, S.F. Assmann, F. Lasaga, and D.L. Hou. A multi-band approach to arterial traffic signal optimization. *Transportation Research part B*, 25B(1):55 – 74, 1991.
- Mohammad M. Hamed, Hashem R. Al-Masaeid, and Zahi M. Bani Said. Short-term prediction of traffic volume in urban arterials. *Journal of Transportation Engineering*, 121(3):249 – 254, 1995.
- Larry K. Head. Event-based short-term traffic flow prediction model. *Transportation Research Record*, 1510:45 – 52, 1995.
- Tsin Hing Heung, Tin Kin Ho, and Yu Fai Fung. Coordinated road-junction traffic control by dynamic programming. *IEEE Transactions on Intelligent Transportation Systems*, 2005.
- B.G. Heydecker. A decomposition approach for signal optimisation in road networks. *Transportation Research Part B*, 30(2):99 – 114, 1996.
- J.D. Leonard II, B. Ramanathan, and W.W. Recker. A real-time information processing algorithm for the evaluation and implementation of atms strategies. *IEEE IV1992 Intelligent Vehicles Symposium. Proceedings*, 1992.
- Steen Merlach Lauritzen. Evaluation of dogs. *Danish Road Directorate*, 2004. [in Danish].
- P. Mirchandani and L. Head. A real-time traffic signal control system: architecture, algorithms, and analysis. *Transportation Research Part C: Emerging Technologies*, 9:415 – 432, 2001.
- P.B. Mirchandani and N. Zou. Queuing models for analysis of traffic adaptive signal control. *IEEE Transactions on Intelligent Transportation Systems*, 8(1):50 – 59, 2007.
- Chronis Stamatiadis Nathan H. Gartner. Progression optimization featuring arterial- and route-based priority signal networks. *Intelligent Transportation Systems*, 2004.
- Michael Patriksson. Sensitivity analysis of traffic equilibria. *Transportation Science*, 38(3):258 – 281, 2004.

- B. Ramanathan, M.G. McNally, and R. Jayakrishnan. Formulation of modern signal control operations as a non-linear mixed integer program. *Vehicle Navigation and Information Systems Conference, 1995. Proceedings. In conjunction with the Pacific Rim TransTech Conference. 6th International VNIS. 'A Ride into the Future'*, pages 165 – 171, 1995.
- Nagui Roupail, Andrzej Tarko, and Jing Li. *Traffic Flow Theory – A State of the Art Report*, chapter Traffic Flow at Signalized Intersections. Turner-Fairbank Highway Research Center, 2001.
- A.A. Saka, G. Anandalingam, and N.J. Garber. Traffic signal timing at isolated intersections using simulation optimization. *Proceedings of the 1986 Winter Simulation Conference*, 1986.
- J.J Sanchez, M. Galan, and E. Rubio. Genetic algorithms and cellular automata: a new architecture for traffic light cycles optimization. *Congress on Evolutionary Computation, CEC2004*, 2:1668 – 1674, 2004.
- Michael Shenoda and Randy Machemehl. Development of a phase-by-phase, arrival-based, delay-optimized adaptive traffic signal control methodology with metaheuristic search. Technical Report SWUTC/06/167863-1, Southwest Region University Transportation Center, Texas Transportation Institute, October 2006.
- D. Sun, R.F. Benekohal, and S.T. Waller. Multiobjective traffic signal timing optimization using non-dominated sorting genetic algorithm. *IEEE IV2003 Intelligent Vehicles Symposium. Proceedings*, pages 198 – 203, 2003.
- H. Taale and H.J. van Zuylen. Integrated anticipatory control. Technical report, Delft University of Technology and AVV Transport Research Centre, 2004.
- Sei Takahashi, Hideo Nakamura, Hiroshi Kazama, and Tomokazu Fujikura. Genetic algorithm approach for adaptive offset optimization for the fluctuation of traffic flow. *The IEEE 5th International Conference of ITS*, 2002.
- Fitsum Teklu, Agachai Sumalee, and David Watling. A genetic algorithm approach for optimizing traffic control signals considering routing. *Computer-Aided Civil and Infrastructure Engineering*, 22:31 – 43, 2007.
- Andreas Warberg. Green wave traffic optimization. Technical report, Technical University of Denmark, 2007.
- J.G. Wardrop. Some theoretical aspects of road traffic research. *Proceedings Institute of Civil Engineering*, 1952.
- F.V. Webster. Traffic signal setting. *Great Britain Department of Scientific and Industrial Research*, 1958.
- J.Q. Ying, H. Lu, and J. Shi. An algorithm for local continuous optimization of traffic signals. *European Journal of Operational Research*, 181:1189 – 1197, 2007.