

## The Wien Bridge Oscillator Family

**Lindberg, Erik**

*Published in:*  
Proceedings of the ICSES-06

*Publication date:*  
2006

[Link back to DTU Orbit](#)

*Citation (APA):*  
Lindberg, E. (2006). The Wien Bridge Oscillator Family. In Proceedings of the ICSES-06 (pp. 189-192)

## DTU Library

Technical Information Center of Denmark

---

### General rights

Copyright and moral rights for the publications made accessible in the public portal are retained by the authors and/or other copyright owners and it is a condition of accessing publications that users recognise and abide by the legal requirements associated with these rights.

- Users may download and print one copy of any publication from the public portal for the purpose of private study or research.
- You may not further distribute the material or use it for any profit-making activity or commercial gain
- You may freely distribute the URL identifying the publication in the public portal

If you believe that this document breaches copyright please contact us providing details, and we will remove access to the work immediately and investigate your claim.

# The Wien Bridge Oscillator Family

Erik Lindberg, IEEE Lifemember

**Abstract**—A tutorial in which the *Wien bridge family* of oscillators is defined and investigated. Oscillators which do not fit into the Barkhausen criterion topology may be designed. A design procedure based on initial complex pole quality factor is reported. The dynamic transfer characteristic of the amplifier is studied.

## I. INTRODUCTION

When you want to design an oscillator the **Barkhausen Criterion** is normally used as a starting point. It is based on an amplifier and a frequency determining feed-back circuit. When the loop gain is 1 and the phase-shift is a multiply of  $2\pi$  a linear circuit with poles on the imaginary axis is obtained i.e. an ideal oscillator is designed [1], [2]. In order to start-up oscillations some parameters are changed so that the poles are in the right half of the complex frequency plane (*RHP*). Very little seems to be reported concerning how far out in *RHP* the initial poles should be placed. The linear circuit becomes unstable and the signals will grow until infinity i.e. we must introduce nonlinearity in order to limit the signal amplitude. The Wien Bridge oscillator is normally based on an amplifier

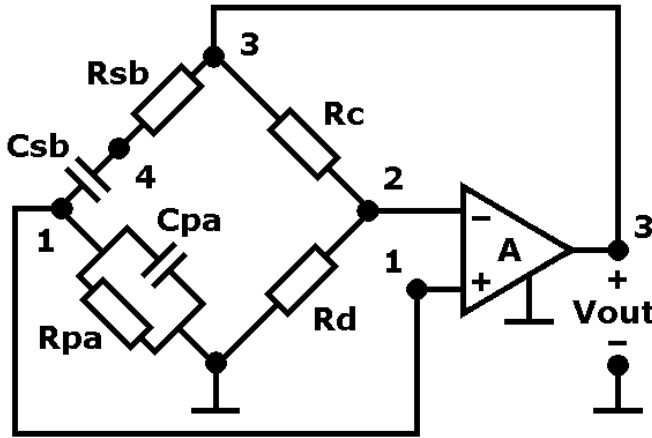

Fig. 1. A Wien bridge oscillator.

with a positive feed back path build from a series RC circuit and a parallel RC circuit. All possible bridge circuits build from an amplifier with positive and negative feed back path with one series RC circuit, one parallel RC circuit and two resistors are studied. The *Wien bridge family* of oscillators is defined as follows. With reference to figure 1 two of the four branches of the bridge are implemented as resistors and the other two branches as a series and a parallel RC circuit. Table I shows the 12 possible combinations of branches. The admittance of the *RCP*-parallel branch is:

$$Y(RCP) = (1 + s \times C_p \times R_p) / R_p \quad (1)$$

Case	YA	YB	YC	YD
1	RCP	RCS	R3	R4
2	RCP	R3	RCS	R4
3	RCP	R3	R4	RCS
4	RCS	RCP	R3	R4
5	R3	RCP	RCS	R4
6	R3	RCP	R4	RCS
7	RCS	R3	RCP	R4
8	R3	RCS	RCP	R4
9	R3	R4	RCP	RCS
10	RCS	R3	R4	RCP
11	R3	RCS	R4	RCP
12	R3	R4	RCS	RCP

TABLE I

THE 12 CASES OF THE WIEN BRIDGE. *RCP* = *Rp* IN PARALLEL WITH *Cp*. *RCS* = *Rs* IN SERIES WITH *Cs*.

The admittance of the *RCS*-series branch is:

$$Y(RCS) = s \times C_s / (1 + s \times C_s \times R_s) \quad (2)$$

In the following a design procedure based on the characteristic equation for a general circuit with an operational amplifier (*op amp*) and both positive and negative feed-back is reported. The quality factor of a complex pole pair is defined and used for placement in *RHP* of the initial complex pole pair assuming ideal *op amp*. The dynamic transfer characteristic of the *op amp* is investigated. Systematic modifications for chaos are studied.

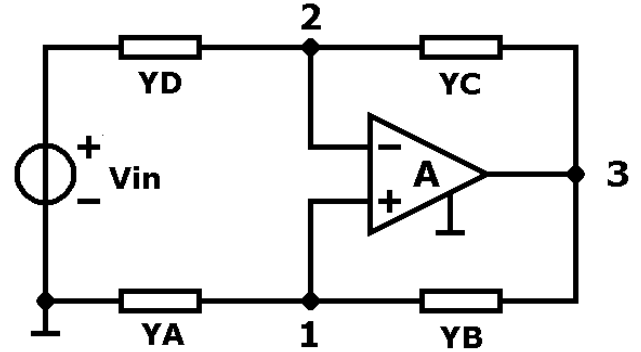

Fig. 2. An amplifier with positive and negative feed-back,  $V(3) = A \times V(1) - A \times V(2)$ .

## II. THE CHARACTERISTIC EQUATION

Figure 2 shows the general circuit which is an *op amp* with positive and negative feed-back. If we introduce memory elements - capacitors, coils, hysteresis - in the four admittances various types of oscillators may be obtained. The nonlinearity needed for oscillations may be introduced as nonlinear losses or hysteresis in connection with the memory elements. If we

introduce linear memory elements with no hysteresis either a nonlinear transfer characteristic of the amplifier or nonlinear loss elements - e.g. thermistors or diodes - must be introduced. Let us assume that the amplifier is a perfect amplifier with infinite input impedance, zero output impedance and piecewise linear gain  $A$ . The gain is very large for small signals and zero for large signals. Now a network-function may be calculated e.g. the transfer function  $V(3)/V_{in}$ . The relation between the output voltage  $V(3)$  and the input voltage  $V_{in}$  becomes:

$$V(3) \times \left( \frac{YB}{YA+YB} - \frac{YC}{YC+YD} - \frac{1}{A} \right) = V_{in} \times \left( \frac{YD}{YC+YD} \right) \quad (3)$$

If we observe that  $V(3)$  is different from zero when  $V_{in}$  is zero then the coefficient of  $V(3)$  must be zero i.e.

$$\left( \frac{YB}{YA+YB} - \frac{YC}{YC+YD} - \frac{1}{A} \right) = 0 \quad (4)$$

Equation (4) is called the **characteristic equation**. For infinite gain ( $A = \infty$ ) the characteristic equation becomes:

$$(YA \times YC) - (YB \times YD) = 0 \quad (5)$$

For zero gain ( $A = 0$ ) the equation becomes:

$$(YA + YB) \times (YD + YC) = 0 \quad (6)$$

The **characteristic polynomial** of the linearized differential equations describing the circuit

$$s^2 + 2\alpha s + \omega_0^2 = 0 \quad (7)$$

may be derived from characteristic equation. The poles or the natural frequencies of the circuit - the eigenvalues of the Jacobian of the linearized differential equations - are the roots of the characteristic polynomial.

$$p_{1,2} = -\alpha \pm j \sqrt{\omega_0^2 - \alpha^2} = -\alpha \pm j \omega \quad (8)$$

The **quality factor**  $Q$  of a pole is defined as

$$Q = \sqrt{(\alpha^2 + \omega^2)} / (-2 \times \alpha) \quad (9)$$

It is a measure for the distance of the pole from the imaginary axis. It is seen that  $Q$  becomes  $\infty$  for poles on the imaginary axis.  $Q$  is negative for poles in the right-half-plane (*RHP*) and positive for poles in the left-half-plane (*LHP*). The real part of the pole may be calculated from

$$\alpha = \omega / \sqrt{4 \times Q^2 - 1} \quad (10)$$

or  $2\alpha = \omega/Q$  for large  $Q$ .

### III. DESIGN OF WIEN BRIDGE OSCILLATORS

In the following the 12 cases of the Wien bridge family are investigated. Figure 1 may be redrawn as shown in Fig. 3 which shows case 1 of the Wien bridge family. For infinite gain ( $A = \infty$ ) the coefficients of characteristic polynomial are found from the characteristic equations as:

$$2\alpha = \frac{1}{C_p R_p} + \frac{1}{C_s R_s} - \frac{R_c/R_d}{C_p R_s} \quad (11)$$

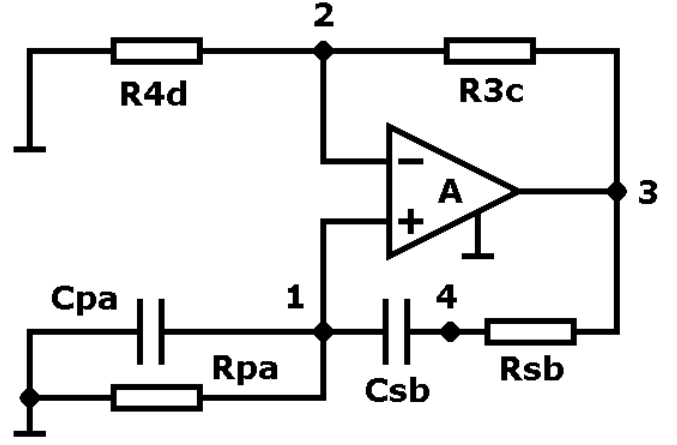

Fig. 3. Wien bridge oscillator case 1.

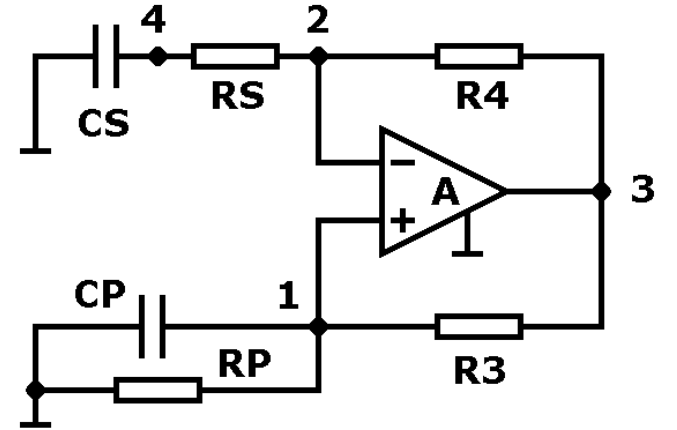

Fig. 4. Wien bridge oscillator case 3.

$$\omega_0^2 = \frac{1}{C_p R_p C_s R_s} \quad (12)$$

For a 10kHz oscillator the capacitors are chosen as:  $C_p = C_s = C = 1\text{nF}$  and the resistors become:  $R_p = R_s = R = 1/(2\pi C f) = 15.91549431\text{k}\Omega$ . The complex pole pair is placed on the imaginary axis for  $2\alpha = 0$  i.e. for  $R_c = 2R_d$ .  $R_c$  is chosen as  $10\text{k}\Omega$  and  $R_d$  becomes  $5\text{k}\Omega$ .  $R_4 = R_d$  is adjusted so that initially the poles are in *RHP*. For  $Q = -10$   $R_d = 4.762\text{k}\Omega$ . For  $Q = -100$   $R_d = 4.975\text{k}\Omega$ . Now the ideal op amp is replaced with a  $\mu\text{A}741$ .

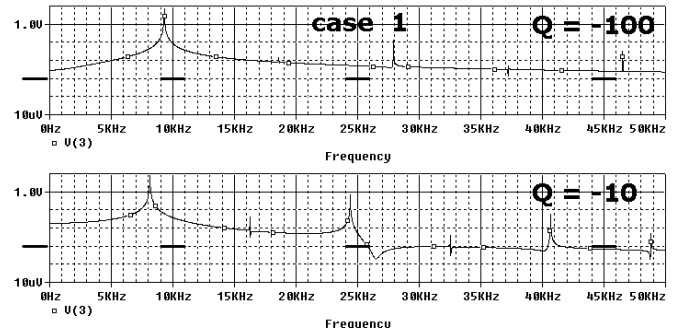

Fig. 5. Wien bridge oscillator case 1.FFT analysis. Op amp  $\mu\text{A}741$ .

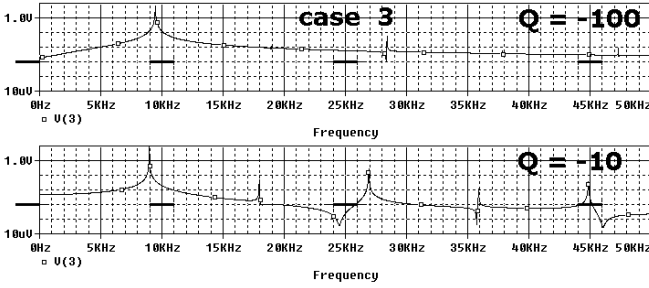

Fig. 6. Wien bridge oscillator case 3.FFT analysis. Op amp  $\mu A741$ .

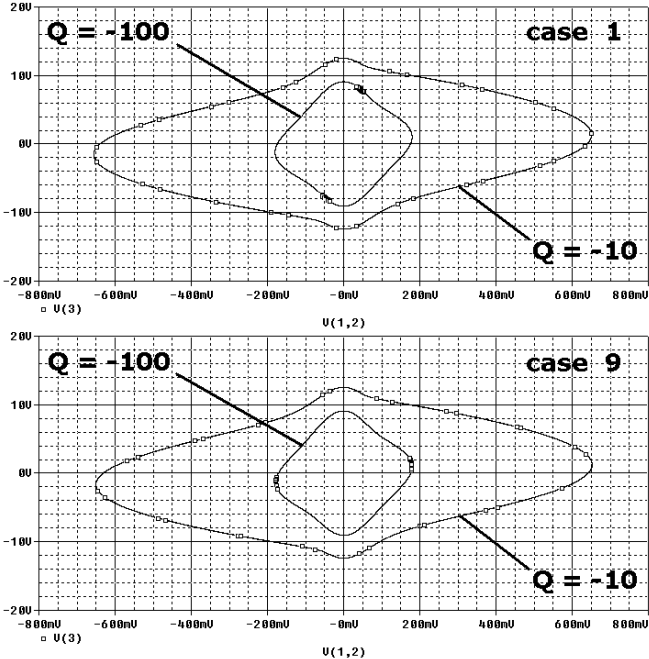

Fig. 7. Wien bridge oscillator case 1 and case 9. Dynamic transfer characteristic of op amp  $\mu A741$ .

Figure 5 and Fig. 6 shows a FFT analysis. It is seen that the basic frequency is more close to the wanted frequency for high  $Q$  than for low  $Q$  as expected. Also it is seen that the distortion "level" is a little higher for  $Q = -100$  than for  $Q = -10$  i.e. if you try to design an oscillator as ideal as possible with the initial complex pole pair as close to the imaginary axis as possible you may end up with a "noisy" oscillator.

Table II summarizes the investigation. It is assumed that  $C_p = C_s$  and  $R_p = R_s$ . The cases may be paired based on the sign of the gain of the amplifier ( 1 and 12, 2 and 11, - , 6 and 7). The values of  $R_3$  and  $R_4$  correspond to the demand of  $2\alpha = 0$  corresponding to either a complex pole pair on the imaginary axis or two real poles symmetric around origo.

The cases 2, 6, 7 and 11 correspond to  $2\alpha = 0$  due to  $R_3 \times R_4 = R_s \times R_p$ . The  $RCP$  and  $RCS$  are in opposite branches of the bridge i.e. in order to obtain an oscillator  $RCP$  and  $RCS$  must be neighbors.

The cases 4, 5, 10 and 12 will only oscillate if the the sign of the amplifier is changed i.e. we have the 4 topologies of

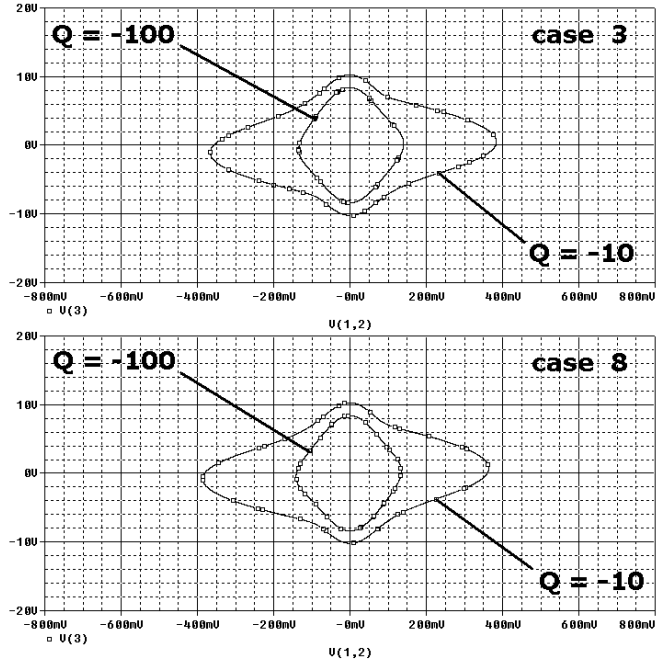

Fig. 8. Wien bridge oscillator case 3 and case 8. Dynamic transfer characteristic of op amp  $\mu A741$ .

Case	YA	YB	YC	YD
1	RCP	RCS	10k $\Omega$	5k $\Omega$
2 *	RCP	*	RCS	*
3	RCP	5k $\Omega$	10k $\Omega$	RCS
4 -	RCS	RCP	5k $\Omega$	10k $\Omega$
5 -	5k $\Omega$	RCP	RCS	10k $\Omega$
6 *	*	RCP	*	RCS
7 (6) *	RCS	*	RCP	*
8 (5)	10k $\Omega$	RCS	RCP	5k $\Omega$
9 (4)	10k $\Omega$	5k $\Omega$	RCP	RCS
10 (3) -	RCS	10k $\Omega$	5k $\Omega$	RCP
11 (2) *	*	RCS	*	RCP
12 (1) -	5k $\Omega$	10k $\Omega$	RCS	RCP

TABLE II

THE 12 CASES OF THE WIEN BRIDGE.  $RCP = R_p$  IN PARALLEL WITH  $C_p$ .  $RCS = R_s$  IN SERIES WITH  $C_s$ .

the cases 1, 3, 8 and 9 as oscillator candidates. This is in agreement with [3].

#### IV. OP AMP DYNAMIC TRANSFER CHARACTERISTIC

The dynamic transfer characteristic of the op amp used is important for the performance of the oscillator. It is a function of the frequency and the quality factor of the initial complex pole pair. The slope of the characteristic in a specific point is the instant gain of the amplifier.

The figures 7 and 8 show the dynamic transfer characteristic of the op amp  $\mu A741$ . It is seen that the characteristics seems to be almost the same for the 4 cases. Only if you want grounded capacitors case 3 should be your choice. It is also seen that the characteristic is "more piece wise linear" for high  $Q$  than for low  $Q$ . Figure 9 shows the dynamic transfer

characteristics for the op amps *TL082* and *AD844*.

It is seen from the characteristic for the *TL082* that it is a high frequency op amp compared with the  $\mu A741$ . For low frequencies - e.g. 1kHz - the same shape is seen for the  $\mu A741$ . Please note that the x-axis for the *AD844* CFOA (current feed-back op amp) transfer characteristic goes from  $-5\text{mV}$  to  $+5\text{mV}$  compared to  $-800\text{mV}$  to  $+800\text{mV}$  for the  $\mu A741$  and the *TL082* i.e. the transfer characteristic for the *AD844* is almost piece wise linear with very high gain for very small values of input voltage  $V(1,2)$  and gain zero for larger values of  $V(1,2)$ . For values of  $R_{comp}$  less than  $1.5\text{M}\Omega$  the oscillations will disappear.

possible you may end up with a "noisy" oscillator.

## REFERENCES

- [1] H. Barkhausen, *Lehrbuch der Elektronen-Rohre*, 3.Band, "Rückkopplung", Verlag S. Hirzel, 1935.
- [2] A.S. Sedra and K.C. Smith, *Microelectronic Circuits 4th Ed*, Oxford University Press, 1998.
- [3] A.S. Elwakil and A.M. Soliman, "A Family of Wien-type Oscillators Modified for Chaos", *Int. Journal of Circuit Theory and Applications*, vol. 25, pp. 561-579, 1997.

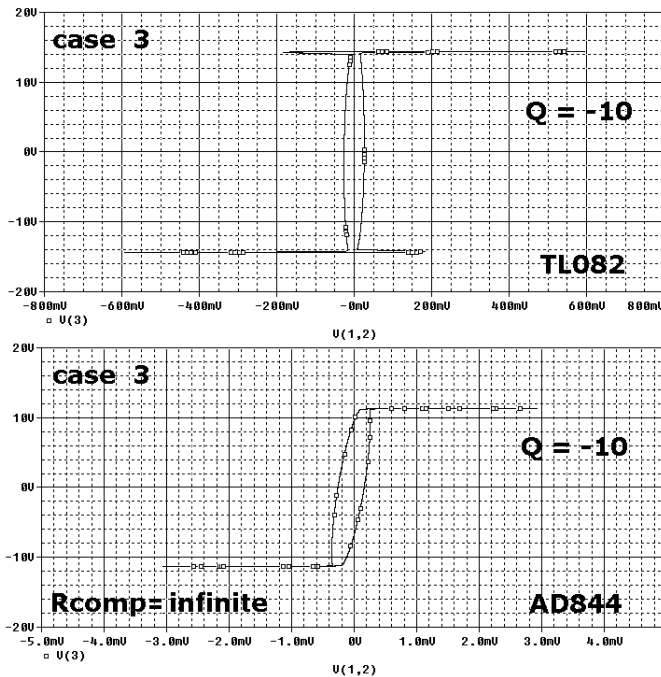

Fig. 9. Wien bridge oscillator case 3.  
Dynamic transfer characteristic of op amp *TL082* and *AD844*.

## V. CONCLUSIONS

Insight in the mechanisms behind the behavior of oscillators is obtained by means of a study of the 4 basic topologies of the Wien bridge oscillator family. Only oscillators based on the nonlinearity of the amplifier are studied. The dynamic transfer characteristic of the amplifier is studied in order to obtain insight in the behavior.

Oscillators which do not fit into the Barkhausen criterion topology may be designed. Oscillators may be designed both with positive and/or *negative* feed-back. As for the Barkhausen criterion an ideal linear oscillator with a complex pole pair on the imaginary axis is the starting point for the design. The placement of the complex pole pair in RHP (the right half of the complex frequency plane) is defined by means of the quality factor  $Q$ .

If you try to design an oscillator as ideal as possible with the initial complex pole pair as close to the imaginary axis as