

Technical University of Denmark



Industrial, Auditorium and Combined Editions

Version 9.0 User Manual. Odeon Room Acoustics Program

Christensen, Claus Lyngø

Publication date:
2007

Document Version
Publisher's PDF, also known as Version of record

[Link back to DTU Orbit](#)

Citation (APA):
Christensen, C. L. (2007). Industrial, Auditorium and Combined Editions: Version 9.0 User Manual. Odeon Room Acoustics Program. Kgs. Lyngby: Odeon A/S.

DTU Library

Technical Information Center of Denmark

General rights

Copyright and moral rights for the publications made accessible in the public portal are retained by the authors and/or other copyright owners and it is a condition of accessing publications that users recognise and abide by the legal requirements associated with these rights.

- Users may download and print one copy of any publication from the public portal for the purpose of private study or research.
- You may not further distribute the material or use it for any profit-making activity or commercial gain
- You may freely distribute the URL identifying the publication in the public portal

If you believe that this document breaches copyright please contact us providing details, and we will remove access to the work immediately and investigate your claim.

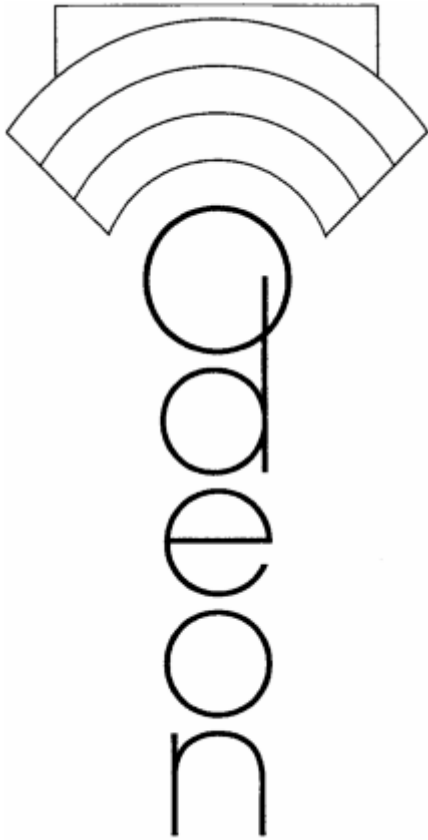

ODEON Room Acoustics Program

Version 9.0

User manual

Industrial,
Auditorium
and
Combined
Editions

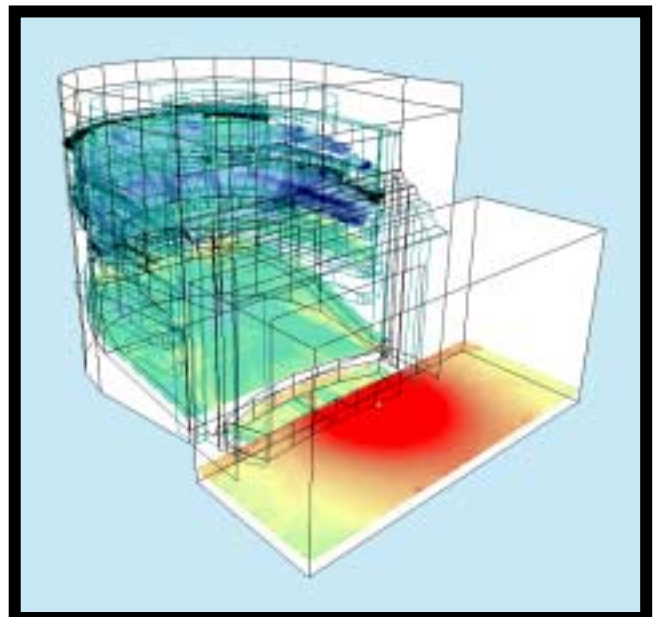

Front figure: The Opera House project for Ankara Congress and Cultural Centre (Architect: Özgür Ecevit, Acoustics: Jordan Akustik, Denmark)

ODEON Room Acoustics Program
Version 9.0
Industrial, Auditorium and Combined Editions

by
Claus Lynge Christensen

ODEON A/S
c/o Acoustic Technology, Ørsted•DTU,
Ørsted's Plads
Technical University of Denmark
Building 352, DK-2800 Lyngby
Denmark

www.odeon.dk

2007

iii

This manual is intended to serve as an introduction on modeling room geometries in Odeon, to the facilities in the ODEON software and to the calculation principles applied in ODEON. It will not cover in depth all facilities included in the Odeon software; explanations of displays, calculation parameters, results, etc. are available as context sensitive help from within the Odeon applications (shortcut F1). It is recommended to use the online help to learn about the specific features available from the different displays, the interpretation of results, calculation parameters, etc.

The contents of this manual are as follows:

Chapter 1 covers installation of the program, changes from previous versions etc.

Chapter 2 is a Short guided tour, introducing the ODEON program and its facilities, offering a short guided tour to the operation of the program, including specification of calculation parameters, definition of receivers, receiver grids, different kind of sources and the presentation of results. Section 2.1 is intended for the Auditorium and Combined editions. Section 2.2 is intended for the Industrial edition. Most of the description on how to operate the program is found here. If you are new to ODEON, this chapter is a *must*.

Chapter 3 covers the geometry modeling. This chapter is always recommended reading; new releases of Odeon often include new facilities which can speed up the modeling process as well as tools for verification of geometries. Some of the facilities are; a parametric modeling language with support for symmetric and semi-symmetric rooms, use of constants, variables, counters, loops etc., extensive support for import of CAD models in the .dxf as well as the .3ds (3D Studio Max) format and a stand alone drawing program for modeling of so called extrusion models. Tools for verification of room models are also covered in this chapter.

Chapter 4 deals with the materials to assign to the surfaces of the rooms; absorption, scattering and transparency coefficients. Special materials that may speed up the modeling process and how to extend the material library is also covered in this chapter.

Chapter 5 deals with the auralization options in ODEON Auditorium and Combined; the hardware requirements, how to publish calculated sound examples on the Internet or on audio CD's etc.

Chapter 6 introduces the calculation principles used in the ODEON program. It should not be thought of as a thorough description of all the calculation principles used, merely a short introduction that may give an idea on the capabilities and limitations of the program.

Chapter 7 describes the calculated point response parameters available in ODEON, how they are calculated and how to interpret the results.

Chapter 8 describes the various calculation parameters available in the program. Most of the parameters are automatically set to reasonable values by ODEON; however for special cases you may find adjustment of some of the calculation parameters to be useful.

Chapter 9 is the discussion on quality of results and how to achieve good results. This chapter may be relevant once familiar with the program.

Chapter 10 describes how to extend the library of directivity patterns available for point sources and the use of directivity patterns in the *Common Loudspeaker Format*, CLF.

Happy modeling, Claus Lyngge
Lyngby, April 2007.

Introduction.....	v
Index.....	vii
1 Installation and running the program.....	1-1
1.1 Installing and running the program	1-1
1.2 Troubleshooting	1-2
1.3 Upgrading from previous versions	1-2
1.3.1 Upgrading to version 9.0	1-2
1.3.2 Upgrading from versions earlier than version 8.5.....	1-2
1.3.3 Upgrading from versions earlier than version 8.....	1-2
1.3.4 Major upgrade.....	1-2
1.3.5 Upgrading from version 3 and earlier	1-2
1.3.6 Upgrading from version 3.1 and earlier	1-3
2 Short guided tours.....	2-4
2.1 Short guided tour - Combined and Auditorium editions.....	2-5
2.1.1 Summary of the calculation methods.....	2-13
2.2 Short guided tour – Industrial edition.....	2-15
2.3 Pre-calculated Rooms – Round Robins	2-18
3 Modeling rooms	3-19
3.1 Guidelines on room modeling.....	3-19
3.1.1 Default coordinate system	3-19
3.1.2 Recommended size of a surface.....	3-19
3.1.3 Curved surfaces	3-19
3.1.4 What to model?.....	3-20
3.2 Modeling rooms by typing it into a text file	3-21
3.2.1 The ODEON .Par modeling format /language.....	3-21
3.2.2 Creating a new .Par file - time saving hints.....	3-42
3.2.3 Examples on parametric modeling	3-43
3.3 Odeon Extrusion Modeler.....	3-48
3.4 Importing DXF files.....	3-53
3.4.1 CAD entities supported by ODEON.....	3-53
3.4.2 Performing the import in Odeon	3-55
3.4.3 Editing the imported geometry	3-56
3.5 Model check in ODEON	3-57
3.5.1  Viewing the room in a 3DView	3-57
3.6 Combining geometries.....	3-58
3.6.1  3DGeometry debugger	3-58
3.6.2  Testing Water tightness using 3D Investigate Rays.....	3-59
4 Materials	4-60
4.1 Special Materials	4-60
4.2 Editing and extending the Material Library	4-62
5 Auralization	5-64
6 Calculation Principles	6-70
6.1 Global decay methods	6-70
6.2  Quick Estimate.....	6-70
6.2.1  Global Estimate	6-71
6.3 Calculation of Response from Sources to Receivers	6-71
6.4 The 'Late ray' reflection method of ODEON.....	6-75
6.5 The Reflection Based Scattering coefficient.....	6-75
6.6 Oblique Lambert.....	6-79
6.7 Sending rays from a source.....	6-81
6.8 Processing reflection data for auralization use in Single Point Response Calculations	6-81
6.9 Calculation method for Reflector Coverage.....	6-81
7 Calculated Room Acoustical parameters	7-83
8 Calculation Parameters - Room Setup and Define Grid.....	8-87

9	Achieving good results	9-90
9.1	Sources of error	9-90
9.1.1	Approximations made by ODEON	9-91
9.1.2	Optimum calculation parameters	9-91
9.1.3	Materials /absorption data.....	9-92
9.1.4	Materials /scattering coefficients	9-92
9.1.5	Measurements	9-92
9.1.6	Receiver position(s).....	9-92
9.1.7	Source-Receiver distance	9-92
9.1.8	Minimum distance from the receiver to the closest surface	9-93
10	Directivity patterns for point sources	10-94
	Common loudspeaker format, CL1 and CF2 files	10-94
10.1	File location for directivity files	10-94
10.2	Creating new directivity patterns in the Odeon .So8 format	10-94
10.3	Entering a directivity plot using the Directivity plot editor	10-94
10.4	Creating a new directivity pattern using a text file as input.....	10-95
10.5	Compatibility with previous versions of ODEON	10-97
9.3	Making a readable text file from a directivity pattern file (.SO8).....	10-97
	Appendix A: Mathematical expressions available in the .Par modeling format	98
	Appendix B: References	99
	Appendix C, Vocabulary	102
	Appendix D Specify Transmission through walls	104

1 Installation and running the program

1.1 Installing and running the program

ODEON comes on a CD-ROM containing the three different editions of Odeon and a demo version of the program. To install the program:

- a) Double-click on the folder with the name of the edition you wish to install.
- b) Run the Setup.exe program in the folder and follow the instructions during the installation process (this will install the ODEON program onto your computer).
- c) To run the program, the supplied hardware HASP key must be inserted into the USB port on the PC (or parallel port if it's a parallel key). If you start the program without the hardware HASP key it can only be used in viewer mode.

On the disk you will also find the directories DemoVersion and Install Noise Explorer (used for upgrading ODEON licences – see upgrading your software licenses below).

ODEON Demo Version

Free demo version, which allows you to carry out all the operations available in Odeon Combined. The only limitation to that program is that you cannot make any calculations to new or modified rooms. You will only be able carry out calculations on the supplied rooms and to view results, which has been calculated in a registered version of Odeon.

Feel free to pass on a copy of the demo version or if the demo has been downloaded from the Internet to pass on the odeon.zip file. The most recent demo version of Odeon can be obtained at <http://www.odeon.dk>.

Installing the Demo Version

Run the Setup.exe program from the DemoVersion\ directory and follow the instructions during the installation process (this will install the Odeon Demo Version onto your computer).

Upgrading your software license

The program Noise Explorer is used here for upgrading Odeon software licenses.

The hardware HASP key contains coded license information that is used to "unlock" the different software.

To upgrade your license install Noise Explorer from the Install Noise Explorer folder onto your computer and make sure the hardware HASP key is attached to the USB port.

- a) Run the Noise Explorer program
- b) Choose the Tools menu and select License Utility...
- c) A window appears showing what licenses are installed on the hardware HASP key.
- d) Note down the Key Identification code (top right corner of the window).
- e) This Key Identification code must be given to *Brüel & Kjær* when an upgrade is ordered, so a new license code can be generated.

When you have received your new License Code:

- a) Start the Noise Explorer program
- b) Choose the Tools menu and select License Utility...
- c) Type in your newly received code in the License code field.
- d) Press Install.
- e) Close the dialog box.

You can now use all the facilities of the new version of the software.

- a) Run the Setup.exe program from the \Combined\, \Auditorium\ or \Industrial\ directories and follow the instructions during the installation process (this will install the relevant edition of the ODEON program onto your computer).
- b) To run the program, the supplied hardware key must be inserted into one of the USB ports on the PC.

1.2 Troubleshooting

Odeon makes heavy use of facilities, which are built-in to the Windows operating systems. If parts of the user interface in Odeon is malfunctioning or looking odd and your computer is running an installation Windows, which has not been updated recently then it is not unlikely that an update to the operating system may help. The Windows update is available at www.microsoft.com.

1.3 Upgrading from previous versions

If you are upgrading from previous versions of ODEON, read on to learn about the changes in ODEON. To learn about the revision history of Odeon please refer to the Help|Contents|Contents|Whats new in Odeon 9.0 tab from within ODEON. Below is a list of issues which you should be aware of when upgrading from previous versions.

1.3.1 Upgrading to version 9.0

When upgrading to version 9.0, you should notice that the file formats used in version 9.0 is only forward compatible, that is, you may load the files from earlier versions of Odeon into ODEON 9.0, but loading a file set which has been loaded by ODEON 9.0 into an earlier edition of ODEON is likely to fail. If, for some reason, you should wish to so anyway you should make use of the File|Open and repair (or in even earlier versions File|Open in safe mode) option instead of the normal File|Open Room.

1.3.2 Upgrading from versions earlier than version 8.5

Natural sources used for auralisation in the Auditorium and Combined editions are handled automatically in ODEON when using directivity patterns that has been marked as NATURAL, please see chapter 5 for further information.

1.3.3 Upgrading from versions earlier than version 8

When upgrading from versions earlier than version 8, it is essential to learn about the new methods for handling of scattering. Chapter 4 covers the material properties to assign to surfaces; chapter 6 covers the calculation principles including handling of scattering and chapter 8 covers the choice of calculation parameters.

1.3.4 Major upgrade

If performing a major upgrade, typically a full version number or more e.g. from version 8 to version 9 then Odeon will install to a new directory for that version without changing the existing installation. If you have no wishes to use the old version of Odeon then it is suggested to uninstall the version(s) using the Windows Start|Control panel|Add /remove programs feature. If keeping an earlier version, be careful not to mix the use of old and new versions – although we do strive to maintain forward compatibility we can not guarantee that a room which has been loaded into a new version of Odeon will also load in an older version without problems.

1.3.5 Upgrading from version 3 and earlier

If you upgrade from a version earlier than 3.0 then we do recommend that you read carefully through the manual as if you were a newcomer to ODEON. There are a huge difference between the early versions of Odeon and the Odeon software as it is today – modeling has been made easier, calculation principles has been enhanced and huge amount of new features has been added.

Project files

The only project file from versions earlier than 3.0, being fully compatible is the surface file (.SUR). The rest of the project files are no longer valid. And even though the .sur format is still valid, it is not recommended to model rooms in this format. The .par format is a much more efficient format.

Directivity files (refereed to as source types in ODEON 2.xx)

ODEON 3.0 and later version uses eight bands of frequency information. Thus, previous directivity files (e.g. OMNI.SOU) are no longer valid. You can translate your old directivity files into new eight-band directivity files (e.g. OMNI.SO8) using the Tools|Directivity patterns|Translate 6 band into 8 band menu entry in the Odeon programme. And more importantly the current version of Odeon supports the Common Loudspeaker Format see chapter 10.

1.3.6 Upgrading from version 3.1 and earlier

If upgrading from ODEON 3.1 or earlier versions of ODEON, the guided tour in chapter 2 and chapter 3 on modeling is indeed recommended reading. Stepping through these chapters will save much time later on - in particular its is important to be familiar with the new geometry modeling language and /or CAD import options before starting large modeling projects.

Upgrading from Odeon 4, 5 and 6 to Odeon 7 and later

If you are having problems loading a room, which was created and worked fine in one of the above listed versions of Odeon, this is probably due to a change that has been made to the surface numbering mechanism applied in Odeon. The numbering mechanism has been changed slightly in order to avoid a conflict, which appeared when using 'symmetric surfaces' along with modeling entities such as CountSurf, Box, Cylinder etc. and in particular to make the automatic surface numbering work without any problems (when the NumbOffset is set to Auto).

If having problems loading a room due to the reasons just mentioned, Odeon will either give an error message that surfaces are repeated in the geometry file or that materials are not applied to all surfaces. In these cases you may wish that Odeon use the old numbering mechanism – this can be done using the Version4 flag in the .par file; As the first line in the geometry file, just after the ### sign, type:

```
Version4 TRUE
```

2 Short guided tours

This chapter will give an introduction to the use of the ODEON program. Depending on the edition purchased; the guided tour differs. The Combined and Auditorium editions are covered in section 2.1 and the Industrial edition is covered in section 2.2.

Buttons, hints and menus

The most common operations can be carried out using buttons. Pointing the mouse on a button will display a small 'bubble' telling the function of that button (a hint). You can also operate the program using menus or shortcut keys. Less common operations are available from the dropdown menu in the top of the Odeon program window – menus will change in order to facilitate the currently selected window or indeed the selected tabsheet in the currently selected window. If looking for a facility in a window, it is quite likely that it can be found in the dropdown menu.

Context sensitive help

Context sensitive help is available using the *F1* shortcut key throughout the program. The help includes description of the facilities available in a particular window, suggestions on the choice of calculation parameters, hints on the evaluation of calculation results, etc. Answers to questions which go on a specific window are found in the context sensitive help rather than in this 'paper'-manual.

Saving data and maintaining consistent results

The ODEON program automatically saves the user-entered data, such as sources and materials with the room. Whenever data need to be defined in order to carry out calculations, ODEON will prompt whether to accept or discard changes. If the changes are accepted, ODEON will automatically erase results that are no longer valid, ensuring that results are always consistent with data entered. *When you close a window, data is automatically saved your upon acceptance*, so as a general rule there are no Save buttons available in ODEON dialogs.

2.1 Short guided tour - Combined and Auditorium editions



Run the ODEON application

You will find the ODEON program at the Windows Menu Start|Programs|Odeon ...|Odw. Execute the program and begin the tour.



Open a room model to work on

Click the Open a room model button to select a room. Room files containing the geometries for ODEON carry the extension .par (or .sur for compatibility with previous version of ODEON) and are plain text files following the specifications outlined in chapter 3. For this guided tour select the room model named Example.par.



3D View

Have a look at the room. Whenever ODEON loads a room, it is displayed in a 3DView. This allows you to investigate the geometry and check it for errors, etc. Several facilities are available in the 3DView, e.g. rotation, zooming, highlighting selected surfaces and corner numbers etc. Hit the F1 shortcut to get an overview of the facilities and their use.

Having assigned a room, this is a good time to get familiar with the MDI concept (Multiple Document Interface). At this point the title bar of the 3DView will be bright blue (or some other colour) indicating this is the active window. Being the active window, the 3Dview menu item is added to the menu bar next to the toolbar dropdown menu. You can operate the functions of the window using this menu or the shortcut keys displayed in the menu.



Define sources and receivers

Before any calculation can be carried out by ODEON, at least one source will have to be defined. Also a receiver will have to be defined in order to calculate a point response.

In this guided tour we shall define point, line and multi surface sources although only the point source is relevant to this auditorium type of room. Finally we define a receiver.

Click the Source-receiver list button at the toolbar to open the Source-receiver list from which sources and discrete receivers are defined. If the Source-receiver list is already open, but hidden behind other windows, etc., clicking this button will rearrange the program windows as needed.



Define a point source

Click the New point source button in the local toolbar at the right side to open the Point source editor. Enter the values $x = 3$ (metres), $y = 2$ (metres) and $z = 1.2$ (metres)^{1,2}. If you are not sure of the position of the source, you can select the 3D Edit source display. If you do so, you should notice how the menu item 3D Edit Source appears on the dropdown menu, when this window becomes active. The 3D Edit Source-Receiver menu will allow you to operate the 3D display, e.g. use the SPACE key to switch between different predefined views.

Finally set the overall gain to 65 dB (65 is just an arbitrary value). To save the new source just close the Point source Editor and confirm. New sources are by default turned OFF, therefore it will not be visible in the 3D Edit source display. Press the SPACE key to activate the source for the current Job – more on Jobs later on.

If you are running the Auditorium edition of ODEON, define two extra point sources of your own choice and go to the paragraph 'Activate sources'. Otherwise if you are running the Combined edition continue below, defining a line and a multi surface source.



Define a line source (Combined edition)

Click the New line source button to open the line source editor. Enter the values $x = 4$ (metres), $y = 2$ (metres), $z = 2$ (metres), Length = 2 (metres) and Azimuth = 135°.

Finally set the Overall Gain to 65 dB. To save the new source just close the Line source Editor and confirm.

¹ Hint; Use the Tab or Shift+Tab keys to move between fields.

² Depending on the language selected on your computer '.' or ',' is used as decimal point. The decimal separator to use internally in ODEON may also be selected from the Options|Program settings|Other settings entry.



Define a multi surface source (Combined edition)

Click the New multi surface source button to open the Multi surface source editor. Select surface 2001 End wall behind podium for this source and click the Invert normal button or shortcut Ctrl+I to make the multi source radiate into the room (a surface in a multi surface source can radiate energy form one of its two sides or from both its sides). Finally set the Overall gain to 65 dB. To save the new source just close the Multi surface source Editor and confirm.



Surface source (Combined edition)

The facilities of the surface source are fully included in the multi surface source – the **Surface source** is only available for backwards compatibility.



Define a receiver

Click the New receiver button to open the Receiver editor. Enter the values $x = 18$ (metres), $y = -5$ (metres) and $z = 3$ (metres). To save the new source just close the Receiver Editor and confirm.

Define other receivers at:

$$(x, y, z) = (12; 3; 2.2)$$

$$(x, y, z) = (8; 7; 1.5)$$

$$(x, y, z) = (21; 1; 3.6)$$

We will get back to the receivers and sources under the point: Calculating Point Responses.



Assign material properties

Open the Materials List and see how to operate it in the Materials menu.

Assign the following material data to the surfaces in the model:

Surface number	1001	1002	2001	-2002 2002	-2003 2003	2004	3001	3002
Material	901	905	702	702	702	702	702	702
Scatter	0.7	0.7	0.05	0.05	0.05	0.7	0.05	0.05

Hit the F1 shortcut to learn more about scattering coefficients and other material specifications.



Quick Estimate, fast estimation of Reverberation Time

From within the Materials List run the Quick Estimate to get an idea of the order of the size of the reverberation time. Note the longest reverberation time. This calculation is very useful while assigning materials for the evaluation of different materials and their impact on the overall reverberation time. Before leaving the Material list you may want to try this out by selecting different materials. It is also possible to select among the defined sources. However, the source position will only have minimal effect on the estimated reverberation time, unless strong decoupling effects are present in the room.



Room setup, calculation parameters

At this point you should have an idea of the order of size of the reverberation time. To continue the series of calculations you should enter the Room setup and specify the Impulse response length. The Impulse response length should cover at least 2/3 of the reverberation curve; in this case 2000 ms should be sufficient. To learn more about the other parameters available from this page, please press F1.



Global Estimate, a reliable method for estimation of reverberation time

Run Global Estimate and let it run until you are satisfied that the decay curve has become stable, and then press the Derive results button. Note the longest reverberation time. The reverberation time differs from the values calculated by Quick Estimate, because the room shape and the position of absorbing material are taken into account. It is important that the Impulse response length in the Room Setup is at least 2/3 of the reverberation time.



Calculating point responses

At this point we are ready to calculate point responses. Three different point response calculations are available:

- Single Point response offering detailed calculation results and auralization options for a selected receiver.
- Multi Point response offering room acoustical parameters for all the receivers defined in the Receiver list at the Source-receiver list.
- Grid response offering a calculated map of room acoustical parameters, if a grid has been specified from the Define grid menu.

Setup a single point response and run it:

- Select source number 1 as the Receiver towards source for each of the jobs 1 – 4. Notice how the blue cross changes into red in the Source Receiver view, indicating that it has been selected for the selected job.
- Select receiver number 1 as the Single Point receiver for job 1, 2, 3 and 4.
- Activate source 1 in job one, source 2 in job two, source 3 in job three and all three sources in job four. Deactivate source number 1 in job 2 and 3. You can see which sources are active in a selected job by looking at the 3D Source Receiver View.
- Click the Run all button in the local toolbar at the right side to run the jobs and the four Single Point response responses will be calculated.



View Single point response

Select job number 1 in the Job List and click the View Single Point response button when the calculations have ended to see the results. You will find seven tab-sheets available in the Single Point Response window displaying room acoustical parameters, energy curves, Reflection density, reflectograms³, 3D reflection paths and Binaural Room Impulse Response filters (BRIR). You can view results for each of the four jobs by first selecting the job in the Job List, then clicking the View Single Point response button. To learn more about the results and options available from the Single Point response window please press F1 to consult the online help. You may also select the page of interest and investigate the menu which, in response appears at the top menu bar. As a last option play the Binaural Room Impulse Response through headphones using the Ctrl+I keystroke.

If the Multi option had been checked, you would also be able to view the Multi point response results and if the Grid option had been checked and a receiver grid had been defined, you would be able to view the Grid response results. These topics will be covered below. Do note that a result can not be viewed before it has been calculated – once a result has been calculated the relevant cell in the Joblist will turn green in order to indicate that this result is available.



Calculate Multi point

Activate the Multi option from the Job list, by checking the Multi option for job 4; then click the Run all or Run Selected Job button.

When the calculation has finished, select job number 4 in the Job list and click the View Multi button to view the Multi point response results. To learn more about the results and options available from this display; press F1. You may also select the page of interest and investigate the dropdown menu, which as a response appears in the top of the program window.

Note that point responses calculated using the Multi point response option are calculated much faster than Single point responses because no filters are created for auralization use.



Define a receiver grid and calculate grid response

Enter the Define Grid menu and select the two floor surfaces (surface 1001 and surface 1002). Specify the Distance between receivers to 2 (metres) then click the Show grid button. Close the Define Grid dialog to save the grid definition.

³ Reflectograms are only used with point sources and will not contain any relevant information for line and surface sources. If the Transition order is set to zero in the Room setup, then the Reflectogram will, at most, contain one 'reflection' - the direct sound.

Note! If the Define Grid button is disabled this is because some process is open, which requires data to be saved. In this case, it is probably the Estimate Reverberation display that needs to be closed. To find this open window, use the Windows menu item on the menu bar. Other displays containing calculation processes may cause the same kind of disabling of miscellaneous options.

Hint! The grid may also be used for easy positioning the point sources and discrete receivers, which are usually defined in the Source-receiver list. To learn how to operate the 3DGrid display, select the display (and the 3DGrid tab in that window) - then select the 3DGrid|Parameters dropdown menu.

Calculate grids

Click the Job list button again. Activate the Grid option from the Job list, by checking the Grid option for job 1; then click the Run all or Run Selected Job button.

ODEON will now start calculating the Grid response for this job; this may take a while.

When the calculations is finished, select job number 1 in the Job list and click the View grid button to view the grid results. To learn more about the results and options available from this display; press F1.



Calculate Reflector Coverage

Enter the Define reflector surfaces menu and select the podium-ceiling surface (surface 3001). Then click the Calculate reflector coverage button on the main toolbar to calculate the reflector coverage for the selected surface(s).

Reflector coverage calculates the coverage provided by chosen reflecting surfaces, at the first order reflections (or up to fifth order if so desired – using the dropdown menu or shortcut-keys 1 through 5). This is an efficient tool for investigating whether the receiver area is covered by the reflectors or not and if the reflectors are positioned correctly. The 3DBilliard display may also be useful for this purpose.



3D Investigate Rays

The '3D Investigate Rays display visualises the ray tracing as it is carried out during any point response calculation. By default its calculation parameters are also set up as the parameters used for the point response calculations (Single Point, Multi and Grid). This display is a very valuable tool for testing new room models, e.g. to detect missing or misplaced surfaces. It may also give an impression of what is happening in the calculations, e.g. the effect of the scattering assigned to the surfaces. Click the Ok button, then click the Single forward button a few times and note the behaviour of the ray tracing.



3D Billiard

The 3D billiard display is a tool that can be used for investigating or demonstrating effects such as scattering, flutter echoes or coupling effects. A number of billiard balls are emitted from the source and reflected by the surfaces in the room. To speed up the process, set the Dist. per update to a higher value. To visualize a flutter echo, a large Number of billiard balls should be used, e.g. 10000 balls. It's easier to visualize a flutter echo, if rays are only emitted in the relevant plane (XZ, YZ or XY). If the geometry is complicated, it may be hard to see the billiard balls, in that case toggle parts of the geometry off using the T shortcut.

Auralization - Listening to the rooms

At this point you have tried calculation of room acoustical parameters, operating visual display like decay curves, 3D reflection paths, reflectograms etc. Its time to move on, trying the auralization options in ODEON. Two ways of auralization are available in Odeon, a real-time /streaming convolution which produces one or two channel auralization on the fly (with some latency) and off-line convolution allowing auralization with up to 25 simultaneous channels which may be assigned individual signal, delay and level. The result of the off-line convolution is stored in files for later playback. Off-line Auralization supports binaural Auralization using headphones as well as Auralization using a loudspeaker setup (surround sound).



Real-time /streaming convolution – binaural Auralization for headphone playback

Select job number 1 in the Job List and click the Streaming convolution button. This will open the Streaming convolution dialog. Select the Voice Sabine Short file in the Source signal field (this is an anechoic recording of voice stored in a Windows Wave file residing in the directory set in the Options|Program setup|Auralization|Wave signal file Directory). ODEON will start convolving the selected signal file with the selected Binaural Room Impulse Response (BRIR), in this case the BRIR for job 1. Listen to the output over headphones, to benefit from the binaural quality of the auralization.

The real-time auralization facility allows auralization with two simultaneous channels, e.g. simulating the left as well as the right part of an orchestra using a stereo recording as input signal, also, the input from the soundcard may be used directly for auralization (that is, on most computers this is possible) if the windows play and record controls have been correctly setup. Please press F1 from within the Streaming Convolution display to learn more about operating the options available. Before leaving this example you may want to try the Listen to input signal option.

Listen to a stereo setup

The next example will demonstrate how to set up a classic stereo setup with a receiver position and the two loudspeaker positions. To run this example, you need to have a stereo recording stored on your harddisk as a Windows wave file, in 16 bit resolution and at a sampling rate of 44100 Hz (or to be able to use the soundcard as the input). This file, which does not need to be an anechoic recording for this demonstration, should be residing in the directory set in the Options|Program setup|Auralization|Wave signal file Directory.



Enter the Source-receiver list

Make a copy of the point source, source 1. To do this, select source 1 in the Source list then press the C shortcut to copy - this will open the Point Source Editor with the new source; change the Y-coordinate to -4 and type Left source in the Description field.

Following the scheme above, create a copy of source 4; change the Y-coordinate to 4 metres and type right source in the Description field.



Enter the Job list to carry out calculations

First activate source number 4 in job 5 and source number 5 in job 6, then select the receiver and point towards which the receiver is oriented. For both jobs you will be sitting in receiver position 1, looking towards source 1; therefore select source 1 as the Receiver towards source point and receiver 1 as the Single point receiver for both jobs (source number 1 is not activated in Job 5 or nor 6 we are only using this dummy source as a an aiming point for the receiver). You have now set up job 5, left speaker and job 6, right speaker for calculation of the two binaural impulse responses. Click the Run All Jobs to carry out the calculations.



Two channel real time auralization

Select job number 5 in the Job List and click the Streaming convolution button. This will open the Streaming convolution dialog. Select the your stereo input file in the Source signal field. The convolver will begin to convolve an mono version of the input signal with the BRIR which was calculated for job number 5. To obtain 'stereo auralization', select BRIR number 6 as the Secondary BRIR for 2-channel auralization. ODEON will begin convolving the left channel of the input signal through BRIR number 5 and the right channel of the input signal through BRIR number 6 the result being a stereo playback in our simulated room. The process involves four convolutions in parallel, mixing binaural signals, level adjustment and much more, luckily this is all taken care of by ODEON. To learn more about the Streaming convolution please press F1 from within that display. Please notice that ODEON allow the combination of BRIR 5 and 6 because the same Single Point response receiver and Receiver pointing towards source are used in both simulations; after all the same person (receiver) can not sit at more than one place and have more than one head orientation simultaneously.



Offline convolution

The offline convolution more or less repeats what you have tried with the real time convolver, the difference being greater flexibility, more channels allowed, individual adjustment of each channel is allowed, plus auralization results are stored in wave files which may be used on the WEB, CD-ROM's, Power Point presentations etc.

Click the Toggle button to get to the auralization display. This display is divided into a left and a right part. In the left display, mono signals are convolved with Binaural Room Impulse Responses (BRIR's, which have been calculated as part of the Single Point responses), this process may be compared to a binaural recording of a mono signal played through simulated source(s) in the room. The right part of the auralization display (two tables) is a mixer allowing convolved results to be combined into one (wave file) allowing multi channel simulations, e.g. stereo setups, singer versus orchestra etc. The Offline auralization offers greater flexibility than the real-time auralization, allowing full control over which signal to pass through which of the 300 channels available and assigning individual level and delay to each channel. If for some reason you need the auralization output as a wave file it is also the offline auralization, which should be used.

Single channel simulation

First try to create a one-channel simulation of a person speaking from source position 1. In the auralization display, select the Conv. no.1 row and select the Voice Sabine Short file in the signal file field (this is an anechoic recording of voice stored in a Windows Wave file residing in the directory set in the Options|Program setup|Auralization|Wave signal file Directory). To play the selected signal file, make sure this cell is selected; then press the Alt+S shortcut (or the Play wave button).

Adjust the Rcd. Lev (recording level) to -30 dB. Then arrow right to the Job no. column and select Job no. 1 from the dropdown list. Exit the Job no. cell but stay on the same row and the corresponding 3D Source Receiver view is updated to show active sources etc. Click the Run All button to convolve the signal with the BRIR. If other calculations, e.g. point response calculations have to be carried out before the convolution is allowed, ODEON will manage this automatically.



Play auralization file through headphones

Once the calculations have been carried out, click the Play wave result button and listen to the result through headphones. If you have selected the Signal file column in the Convolve BRIR and Signal file table, the (anechoic) input file is played. If any other column in this table is selected, the convolved result file is played.



Convoluting BRIR's with signals and mixing signals

In the following we will assume that you have a stereo recording called MyStereoRecording.wav stored on your computers harddisk in a 16-bit resolution, sampled at 44100 Hz. Toggle to the Auralization display (ALT+T).

First step is to set up two mono playbacks, one playing the left channel of the stereo signal, another playing the right channel.

Left speaker playing left signal

In Convolve BRIR and Signal file table, setup Conv. no. 2 (Row number 2):

- Select a stereo signal file e.g. MyStereoSignal in the Signal file Column.
- Select channel 1 to select the left channel of the signal⁴ in the channel column.
- Select job number 5 in the Job no. column to simulate the left channel being played through the left loudspeaker.
- Adjust the Rcd. Lev. (Recording level) to -40 dB (or use the Overall recording level available in the Auralization setup|Binaural settings, this setting is effective on all convolutions)

Right speaker playing right signal

In Convolve BRIR and Signal file table, setup Conv. no. 3 (Row number 3):

- Select the same signal file as above e.g. MyStereoSignal in the Signal file Column
- Select channel 2 to select the right channel of the signal in the channel column
- Select job number 6 in the Job no. column to simulate the right channel being played through the right loudspeaker.
- Adjust the Rcd. Lev. (Recording level) to -40 dB.

Mixing signals

So far we have setup two mono simulations, one playing the left channel and another one playing the right channel of a stereo signal. To finish the stereo setup we need to mix the two binaural signals together. The binaural mixer is in the right part of the auralization display. If you are using a low-resolution display not all of the display may be visible, however you can drag the borders between (and inside) the tables using the mouse.

Select the Mix. No. 1 in the Mix Convolved wave results into one wave file table. The rightmost table displays the binaural results that are combined in this Mix. Select row 1 in the table and select Conv. No. 2 (the simulation of the playback of the left signal), then select Conv. No. 3 in row 2 (the simulation of the playback of the right signal).

Notice that you may also apply attenuation and a delay to each of the signals in the rightmost table of the mixer. The attenuation corresponds to the attenuation knob on a mixer. The delay is used for delaying the appropriate Convolved signal (and should not be confused with a source delay). An example where the delay feature could be useful is a simulation of an underground station where one signal is the train noise and another is the loudspeaker announcement, the signals are not necessary of

⁴ In a stereo wave file, the first channel is always the left channel and the second channel is always the right channel.

the same length and you may want to delay one of the signals. You may also use the delay if you wish to make noise sources which are playing the same noise signals less correlated, e.g. if ten sources are playing the same 'cocktail party' noise (ten Single Point response Jobs and ten convolutions), apply delays like 0, 2, 3, 5, 7, 11, 13, 17, 19 seconds (or another time unit). You may mix up to 25 convolutions together.

Calculating BRIR's, left signal, right signal and the stereo signal

The stereo setup has now been completed and you may start calculations (Run All). Depending on the source gains you have chosen, you may experience overload or under range, in this case you should adjust the Recording Level (Rcd. Lev.) and /or Mixer level and recalculate. These levels correspond to the levels on a tape-recorder and on a mixer and the problems concerning overload and under range are the same. If levels are too low you will get a poor dynamic range and if too high you will experience clipping. The Out Lev.⁵ in the rightmost columns of the tables should not exceed 0 dB, on the other hand if the output level is say -30 to -50 dB a very poor dynamic range is obtained.



Playing results

When calculations have finished you may play the calculated binaural simulations. Select the relevant table, row and column, then click the play button (or the Alt+S short-cut):

- To play the input signal, select the Signal file column in the Convolve BRIR and Signal file table.
- To play the mono signals convolved with a BRIR select any other column in the Convolve BRIR and Signal file table.
- To play the mixed results, select the relevant row in the mix table.
- Finally to play the individual components in a selected mix, select the relevant row in the rightmost table (mixer level adjustments are not taken into account). These signals are just a repetition of the convolved results from the leftmost table.

Auralisation on loudspeakers

It is possible to create auralization files for playback on a surround sound system. The operation of surround sound auralization is more or less a repetition of the process just described, however there are different hardware requirements and a loudspeaker rig must be defined before Odeon can calculate a surround file which is suited for the surround setup available.

Hardware requirements for loudspeaker auralization

In order to play the surround sound files which can be generated by Odeon, a suitable soundcard such as a 4.1, 5.1 or 7.1 surround soundcard must be installed on the computer and connected to a matching loudspeaker system. The soundcard must also be setup correctly in order to recognize which loudspeakers system it is currently connected to in the relevant software application which comes with the soundcard.

Defining the speaker rig

In order to create surround sound output, enter the Auralization setup and check the Create 2D surround sound impulse response. Secondly click the Define speaker rig button in order to define the positions of your loudspeakers. If you have a common surround soundcard, then click the button for the speaker system which best resembles your system e.g. a 5.1 system. It is possible to fine tune the positions of the loudspeakers in the Speaker list table. Odeon will use this information in order to make corrections for signal delay due to difference in distances from individual loudspeakers to the receivers (if the Compensate speaker delays option is checked) and in order to compensate for difference between the angles which are covered by each two loudspeakers (if the Parameterization option is checked). Even though Odeon performs these compensations it is recommended to use a speaker layout, with as equal angles between the speakers as possible and if possible, with left /right symmetry.

Check that labels displayed in the map of loudspeakers is in agreement with the loudspeaker coordinates entered then, if this is the case close the Define speaker rig dialog. The Auralization setup dialog is still open and it may be a good idea to save the defined speaker rig just defined to a separate archive file, it may be needed at a later point (e.g. if moving Odeon to another computer, upgrading the program etc.)

⁵ The Out lev. displays the level of the sample having the highest value in the resultant wave file – this value should not be confused with loudness or RMS.

A note on mapped speaker rigs

Surround sound files can be mapped by ODEON, if this option has been selected in the Define speaker rig dialog. An example of a mapped file may be a 5.1 surround file which contains 6 channels that should be feed into *front*, *left*, *right*, *left back*, *right back* and *subwoofer* channels. If loudspeaker system, surround soundcard and its setup match this, then the signals will automatically end at the right places.

In order to achieve a high degree of compatibility between software, soundcards and loudspeakers, Windows as well as the native software associated with soundcards are capable of remapping loudspeaker signals, that is if the signals are mapped in the first place. As an example a 7.1 soundcard may have a program (e.g. SoundBlaster has an application called Creative Speaker Settings) which allow you to select the output format to be 5.1 or indeed stereo if that is the layout of your loudspeaker system. In the other end of the signal chain the same thing is the case; if a 5.1 system is asked to play a mapped 7.1 signal then Windows will remap the signal in order to match it with the hardware available (or rather the hardware which the system is aware of). In order to achieve optimum results it is highly recommended that speaker rig defined in Odeon matches that of the physical loudspeaker rig and that the setup of the soundcard is also also in agreement with that.

Calculating surround files

If the speakers have been correctly defined you may enter the auralization setup and calculate the surround results (e.g. click the Run All Jobs button). Once calculations have finished, an extra button will be available in the toolbar in the right side of the Joblist allowing you to toggle between the binaural and surround sound mode (if both options were chosen in the Auralization setup). Click the button until the titlebar in the Joblist display Surround Mode. At this point it should be possible to play impulse responses as well as convolved and mixed files (from the auralization display), using the surround sound hardware.

Trouble shouting - surround playback

There are a few reasons (that we know of) why the playback of surround files may fail (the most obvious not mentioned here):

- Make sure that headphones are disconnected. If the headphones have their own separate connection, then the loudspeaker output may be disconnected when the headphone is connected.
- Playback of surround sound files in Odeon relies on the Windows Media Player which can play this type of multi channel files. Make sure that the media player is up to date; otherwise it may not support this type of files (known as WaveFormatExtensible). It should be possible to update the media player at <http://.windowsupdate.microsoft.com>.
- If Windows Media Player is not the default program for playback of wave files, then the surround files may not play unless the software selected for default playback of wave files is also capable of playing this format. The problem may be solved by telling ODEON where the Media Player resides, this is done in the Options|Program setup|Auralization|Surround Player field e.g. type C:\Program Files\Windows Media Player\wmplayer.exe, if this is where the media player resides. If you are not aware of the location of the wmplayer.exe file, then you may locate it using the Search facility in Windows (found in the Start menu)

Getting further

To familiarise further with ODEON you should try to change some of the materials, sources etc. in the room and make new calculations. A suggestion is to try changing the scattering coefficient on surface 2004 Rear wall behind audience from 0.7 to 0.05 and listen to the change in sound quality (echo problems); Create a copy of the room using the File|Copy files option - then make the changes to this room model. In this way you will have results from both of the rooms present for comparisons.

Pre-calculated Rooms – Round Robins

At this point you have tried the basic functions in ODEON and may want to view results for more realistic rooms. A few pre-calculated examples are covered in section 2.3. The examples include rooms which were used in the 2nd and 3rd Round Robins on Room Acoustic Computer Simulations along with the measured and simulated results.

2.1.1 Summary of the calculation methods

Global Estimation of reverberation time

There are two calculation methods for the calculation of global reverberation time built into ODEON. The two global estimation methods for reverberation times, estimates reverberation time for the complete room with one selected source position.



Quick estimate is the fast method, which is found in the Material List. This method is based on the Sabine, Eyring and Arau-Puchades formulas and as such assumes diffuse field conditions. Diffuse field cannot be assumed if:

- the room absorption is unevenly distributed.
- the room contains de-coupling effects, e.g. connected corridors or niches.

Thus the results given by Quick Estimate should not be considered to be a final result. Even so the method is useful in the initial work on assigning reasonable materials to the surfaces in the room.



Global estimate is a more precise method, which doesn't make any assumptions about diffuse field conditions and as such, it is a more reliable method for estimation of global reverberation time.

- For workrooms where all absorption is often situated in the ceiling region and sources are situated in the floor region the RT predicted by Global Estimate will typically be longer than the values predicted by Quick Estimate, a factor two is not unlikely if walls are basically smooth.
- In auditoriums the opposite is the case, because the dominant absorption area (the audience) is close to the source.

In any case the RT's predicted by Global Estimate is the most reliable – provided that proper scattering coefficients have been entered. The principle of the method was first suggested by Schroeder [48].



Point Response calculations

The Point response calculations estimate not only RT, but also room acoustic parameters like Clarity, Deutlichkeit, SPL, SPL_A, STI and LF₈₀ (see chapter 7). The calculated results can be thought of as a simulated measurement. Calculated results relates to:

- a number of active sources
- one receiver position
- orientation of the receiver (for LF₈₀, LG80* and auralization)

The orientation of the receiver(s) in a particular job is set in the Job list by selecting a point source through which the receivers are looking. This point source need not be active; it may indeed be an inactive dummy source which is only used as an aiming point. There are three kinds of point response calculations; the Single Point Response, the Multi Point Response and the Grid Response.



Single Point Response is calculated for a selected receiver position, which must be defined in the Source-Receiver list. The Single Point Response is the most detailed calculation method allowing:

- Prediction of room acoustical parameters (including stage parameters)
- Display of predicted Decay curves
- Tracking of individual reflections in a reflectogram and display and tracing the reflection(s) in 3D displays of the room e.g. for tracking down echo problems.
- Auralization (see chapter 5)



Multi point response calculates room acoustical parameters for all the discrete receiver positions defined in the Source-receiver list.



Grid Response calculates room acoustical parameters for a mapped receiver area. The surfaces over which grids should be calculated are selected in the Define Grid display.

The Auralization features are available from within the Job list. Auralization is based impulse responses (BRIR's and Surround Impulse responses), which may be calculated as a part of the Single Point Response. Fast and easy to use binaural auralization is provided by the Steaming convolution facility – to learn more about this facility use the online help from within the JobList. If greater flexibility is needed a separate auralization display appears when using the toggle button (Alt+T) from within the JobList.

Offline convolution for flexible Auralization

In the left part of the auralization display mono signals are convolved with impulse responses - in the right part of the auralization display, such convolved signals may be mixed together in order to create multi channel simulations. The Auralization results may be either two channel signals (binaural), which should be listened to through headphones or multi channel signals to be played through a surround system.

The **mono input signal** is selected in terms of a signal file and a channel in that file. In a stereo signal file, channel 1 is the left channel signal, channel 2 is the right channel signal and average is the average signal of the channels included in the file. A signal file is typically 1-channel (mono) or 2-channel (stereo), but may in principle contain many channels.

The **impulse response** is selected in the Job no column and refers to the Single Point Response with that job number. Once the impulse response has been selected, the point through which the receiver is oriented is displayed in the corresponding 3D display and the used receiver position is displayed in the table in the auralization display.

The **recording level** may have to be adjusted in order to get a good dynamic range or on the other hand to avoid overload. The output level achieved when convolution has been carried out is displayed in the rightmost column and should never exceed 0 dB. The recording level corresponds to the recording level on a tape-recorder. If you wish to compare different simulations you should use the same recording level.

Creating multi channel auralization is by nature a little complicated and you should get familiar with one-channel simulations before using this feature (the mixer).

Multi channel simulations can be created using the mixer in the auralization display (the two rightmost tables). The mixer allows you to mix together up to 25 (one-channel) simulations from the Convolve BRIR and Signal file table. The simulations can only be mixed together if they:

- use the same receiver position (Point Response Receiver)
- use the same orientation (receiver towards source)

To check this, scroll through the Convolve BRIR and Signal file table and view the receiver column (Rec.) and the receiver towards source point, which is displayed as a red cross in the corresponding 3D display.

Other facilities in ODEON

Apart from the features demonstrated in the above tour, ODEON also contains facilities for:

- Calculation of transmission through walls – this issue is covered in Appendix D.
- Copying the project files generated by ODEON (available from the Files menu item)
- Deleting calculation files or result files (available from the Files menu item).
- Archiving project files in one single compressed /zipped file, for efficient and safe storage or for easy posting by e-mail (available from the Files menu item).
- Tools for detecting errors in a new model, e.g. warped or overlapping surfaces (available from the Toolbar dropdown menu).
- Setup for printouts (available from the Options|Program Setup menu item).
- Export of calculated data in ASCII /text format for use in a spreadsheet or other post processing.

2.2 Short guided tour – Industrial edition



Run the ODEON application

You will find the ODEON program at the Windows Menu Start|Program files|Odeon ...|Odw. Execute the program and begin the tour.



Open a room model to work on

Select the Open a room model button to select a room. The room files containing the geometries for ODEON carry the extension .Par or (.Sur for compatibility with previous versions of ODEON) and is plain ASCII /text files following the format outlined in chapter 3. For this guided tour select the room model named Example.par.



3DView

Have a look at the room. Whenever ODEON loads a room, it is displayed in a 3DView. This allows you to investigate the geometry and check it for errors, etc. Several facilities are available in the 3DView; e.g. rotation, zooming, highlighting of selected surfaces and corner numbers etc. Press F1 to get overview of the facilities and their use.

Having assigned a room, this is a good time to get familiar with the MDI concept (Multiple Documents Interface). At this point the title bar of the 3DView will be blue (or some other colour) indicating that this is the active window. Being the active window, the 3DView menu item is added to the menu bar next to the Toolbar dropdown menu. You can operate the functions of the window using this menu or the shortcut keys displayed in the menu.



Define sources and receivers

Before any calculation can be carried out in ODEON, one or more sources will have to be defined. Of course a receiver will also have to be defined in order to calculate a point response. In this guided tour we shall define a point, a line and a surface source. Finally we define a receiver.

Click the Source-receiver list button at the toolbar to open the Source-receiver list from which sources and discrete receivers are defined. If the Source-receiver list is already open, but hidden behind other windows, etc., clicking this button will rearrange the windows as needed.



Define a point source

Click the New point source button in the local toolbar at the right side to open the Point source editor. Enter the values $x = 3$ (metres), $y = 2$ (metres) and $z = 1.2$ (metres)^{6,7}. If you are not sure of the position of the source, you can select the 3D Edit source display. If you do so, you should notice how the menu item 3D Edit Source appears on the dropdown menu, when this window becomes active. The 3D Edit Source-Receiver menu will allow you to operate the 3D display, e.g. use the SPACE key to switch between different predefined views.

Finally set the overall gain to 65 dB (65 is just an arbitrary value). To save the new source just close the Point source Editor and confirm. New sources are by default turned OFF, therefore it will not be visible in the 3D Edit source display. Press the SPACE key to activate the source for the current Job – more on Jobs later on.

Hint; Use the Tab or Shift+Tab shortcuts to move between data fields.



Define a line source

Click the New line source button to open the Line source editor. Enter the values $x = 2$ (metres), $y = 2$ (metres), $z = 2$ (metres), Length = 2 (metres) and Azimuth = 135°.

Finally set the Overall gain to 65 dB. To save the new source just close the Line source Editor and confirm.

⁶ Hint; Use the Tab or Shift+Tab keys to move between fields.

⁷ Depending on the language selected on your computer '.' or ',' is used as decimal point. The decimal separator to use internally in ODEON may also be selected from the Options|Program settings|Other settings entry.



Define a multi surface source

Click the New multi surface source button to open the Multi surface source editor. Select surface 2001 End wall behind podium for this source and click the Invert normal button to make the multi source radiate into the room (a surface in a multi surface source can radiate energy from one of its two sides or from both its sides). Finally set the Overall gain to 65 dB. To save the new source just close the Multi surface source Editor and confirm.



Surface source The facilities of the surface source are fully included in the multi surface source – the surface source is only available for compatibility reasons.



Define receivers

Click the New receiver button to open the Receiver editor. Enter the values $x = 1.5$ (metres), $y = -0.5$ (metres) and $z = 1.65$ (metres). To save the new source just close the Receiver Editor and confirm.

Define other receivers at:

$$(x, y, z) = (12; 3; 2.2)$$

$$(x, y, z) = (8; 7; 1.5)$$

$$(x, y, z) = (21; 1; 3.6)$$

We will get back to the receivers and the activated sources under the point: Calculating Point Responses.



Assign material properties

Open the Materials List and see how to operate in the Materials menu.

Assign the following material data to the surfaces in the model:

Surface number	1001	1002	2001	-2002 2002	-2003 2003	2004	3001	3002
Material	901	905	702	702	702	702	702	702
Scatter	0.7	0.7	0.05	0.05	0.05	0.7	0.05	0.05

Hit the F1 shortcut to learn more about scattering coefficients and other material specifications. Notice high scattering coefficients are used on the floor and sidewalls in order to model machinery and beams.



Quick Estimate, fast estimation of Reverberation Time

From within the Materials list run the Quick Estimate to get an idea of the reverberation time. Note the longest reverberation time. This calculation is very useful while assigning materials for evaluating different materials and their impact on the reverberation time. Before leaving the Quick Estimate you may want to try this out by choosing different materials. It is possible to select among the defined sources. However, the source position will only have minimal effect on the global estimated reverberation time, unless strong coupling effects are present in the room.



Room setup, calculation parameters

At this point you should have an idea of the order of size of the reverberation time. To continue the series of calculations you should enter the Room setup and specify the Impulse response length. The Impulse response length should cover at least 2/3 of the decay curve; in this case 2000 ms should be sufficient. To learn more about the other parameters available from this page, use the F1 shortcut.



Global Estimate, reliable method for estimation of reverberation time

Run Global Estimate and let it run until you are satisfied that the decay curve has become stable, then press the Derive results button. Note the longest reverberation time. The reverberation time differs from the values calculated by Quick Estimate, because the room shape and the position of absorbing material are taken into account. It is important that the Impulse response length in the Room Setup is at least 2/3 of the reverberation time.



Calculating point responses

At this point we are ready to calculate point responses. Two different point response calculations are available in the Industrial edition:

- Multi Point offering room acoustical parameters for all the receivers defined in the Receiver List at the Source Receiver List.
- Grid offering a calculated map of room acoustical parameters, if a grid has been specified from the Define grid menu.

Setup a Multi point response and run it:

- Activate source 1 in job one, source 2 in job two, source 3 in job three and all three sources in job four.
- Turn on the Multi option for the jobs 1 to 4 in order to calculate the point responses for the four receivers you have defined. Notice how the active sources are displayed in the 3D Source-receiver display as you scroll through the Job list.



Viewing results

When the calculation has finished, select job number 4 in the Job list and click the View Multi button to view the Multi point response results. To learn more about the results and options available in this window; press F1. You may also select the page of interest and investigate the dropdown menu, which then appears in the top of the program window. You can view the Multi point response results for each of the four jobs by first selecting the job in the Job List, then clicking the View Multi Point response button.

If the Grid option had been checked and a receiver grid had been defined, you would be able to View Grid Response results as well. This topic will be covered below.



Define a receiver grid and calculate grid response

Enter the Define Grid menu and select the floor surfaces (surface 1001 and surface 1002). Specify the Distance between receivers to 2 (metres) then click the Show Grid button.

Note! If the Define Grid button is disabled this is because some process is open, which requires data to be saved. In this case, it is probably the Estimate Reverberation display that needs to be closed. To find this open window, use the Windows menu item on the menu bar. Other displays containing calculation processes may cause the same kind of disabling of miscellaneous options. Close the Define Grid dialog to save the grid definition.

Calculate grids

Click the Job list button again. Activate Grid option from the Job List, check the Grid option for job 1 - 4 and click the Run All button. ODEON will now start calculating the grid response for the four jobs; this may take a while. When the calculations have finished, select job number 1 in the Job List and click the View Grid Response button to view the grid results. To learn more about the results and options available from this display; use the F1 shortcut.



3D Investigate Rays

3D Investigate Rays visualises the ray tracing as it is carried out during any point response calculation. By default its calculation parameters are also set up as the parameters used for the point response calculations (Single Point, Multi and Grid). This display is a very valuable tool for debugging of new models, e.g. to detect missing or misplaced surfaces. It may also give an impression of what is happening in the calculations, e.g. the effect of the scattering assigned to the surfaces. Click the Ok button, then click the Single forward button a few times and note the behaviour of the ray tracing.



3D Billiard

The 3D billiard display is a tool that can be used for investigating or demonstrating effects such as scattering, flutter echoes or coupling effects. A number of billiard balls are emitted from the source and reflected by the surfaces in the room. To speed up the process, set the Dist. per update to a higher value. To visualize a flutter echo, a large Number of billiard balls should be used, e.g. 10000 balls. It's easier to visualize a flutter echo, if rays are only emitted in the relevant plane (XZ, YZ or XY). If the geometry is complicated, it may be hard to see the billiard balls, in that case toggle parts of the geometry off using the T shortcut.

2.3 Pre-calculated Rooms – Round Robins

At this point you have tried the basic functions in ODEON and may want the view results for more realistic rooms. In the room directory you will find pre-calculated results in the rooms Elmia RoundRobin2 detailed.par and PTB_Studio open curtains detailed model.par which were the rooms used as test objects in the 2nd [39] and 3rd [47] International Round Robins on Room Acoustic Computer Simulations. Geometry, absorption data, source and receiver positions as well as the measured room acoustical

parameters are those supplied to all participants in the Round Robins, by the PTB in Germany - these data are publicly available at www.ptb.de. To compare results calculated by Odeon with those measured in the real rooms:

- Open the room in question.
- Open the JobList – the Shift+Ctrl+J shortcut.
- Select one of the pre-calculated Multi point response jobs (job one or two) in the Joblist and open it – the Alt+M shortcut.
- Select the Measured versus simulated tab-sheet in the Multi Point display.

A couple of other examples

Hagia Irene.par is a model of a Byzantine church in Istanbul which like the examples above also includes the measured room acoustical parameters.

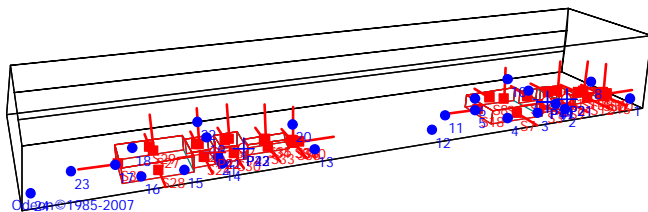

Another example Studstrup.par is also available; this is a model of a turbine hall at a power plant – measured SPL(A) is included in that example. This example is only available for the Auditorium and Combined editions.

If you wish to carry calculations faster, you may enter the Room setup and select the Engineering setting this will provide results approximately 5 times faster without much loss in quality in results.

Other facilities in ODEON

Apart from the features, which have been demonstrated in the above tour, ODEON also contains facilities for:

- Calculation of transmission through walls – this issue is covered in Appendix D.
- Copying the project files generated by ODEON (available from the Files menu item).
- Deleting calculation or result files (available from the Files menu item).
- Archiving project files in one single compressed /zipped file, for efficient and safe storage or for easy posting by e-mail (available from the Files menu item).
- Tools for detecting errors in a new model, e.g. warped or overlapping surfaces (available from the Toolbar dropdown menu).
- Setup for print-outs and graphics (available from the Options|Program Setup menu item).

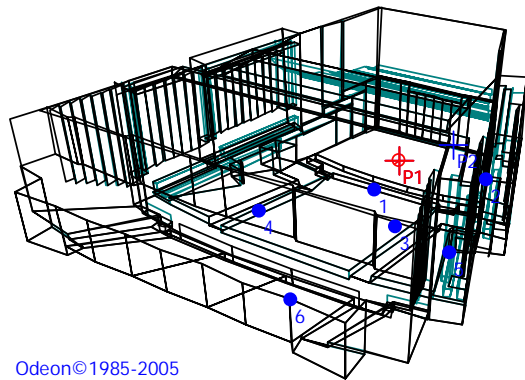

parameters are those supplied to all participants in the Round Robins, by the PTB in Germany - these data are publicly available at www.ptb.de. To compare results calculated by Odeon with those measured in the real rooms:

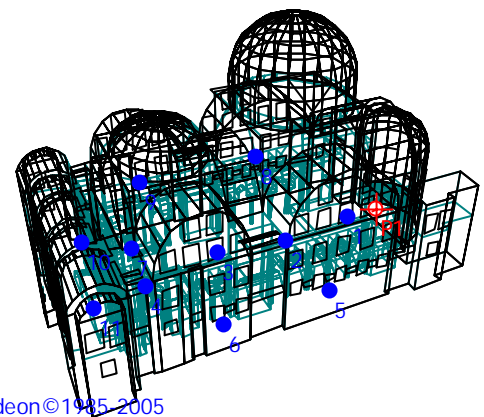
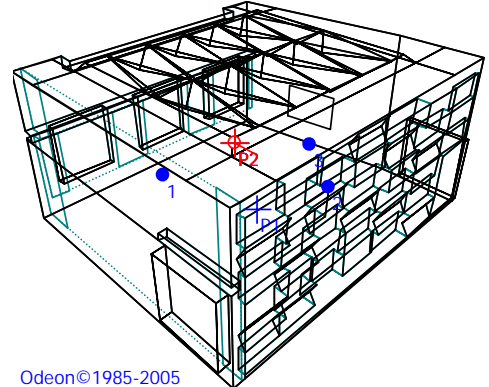

3 Modeling rooms

Creating new room models is probably the most time consuming task in room acoustical modeling. However good modeling practice will greatly reduce the time used for modeling and remodeling rooms.

In order to study a room in ODEON, a file containing the description of the room's geometry will have to be created. All subsequent derivative files and result files are created and managed by ODEON.

The file containing the room model must be written as an ASCII text file, having the file extension .Par (the 'old' ODEON .sur file format is also allowed though not described in this manual). You can choose to create the geometry file either by typing the model data directly into a text file in the supplied text editor OdwEdit, using the format described in section 3.2, using the Odeon Extrusion Modeler described in section 3.3 or a third party CAD program (e.g. IntelliCAD, 3DStudioMax, MicroStation, Rhino or AutoCAD) which is capable of creating 3D surface models and exporting these as .dxf files as described in section 3.4. Finally you may combine the different modeling methods; import a CAD model from a CAD program and extend or correct it using tools which come with Odeon.

No matter which approach you choose for modeling, always check the validity of the models. The room model must form a (almost) closed enclosure. It should also be (almost) free from warped (twisted), duplicate or overlapping surfaces. ODEON has several tools for checking models for such problems. The tools are presented in section 3.5. It is suggested that you always use these tools when working on models of some complexity.

3.1 Guidelines on room modeling

Whether you choose to model your rooms by typing your rooms directly into a text file or using a CAD program, there are considerations that are common to either case. Some guidelines of general nature are given below.

3.1.1 Default coordinate system

To make it as easy as possible to operate ODEON, the following orientation of room geometries should be applied (using a concert hall as the example):

- X-axis pointing towards the audience
- Y-axis pointing to the right as seen from the audience
- Z-axis pointing upwards

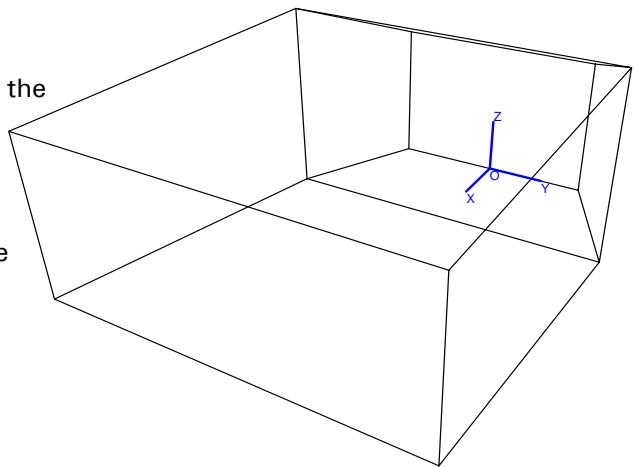

3.1.2 Recommended size of a surface

The most important theoretical consideration concerns the size of surfaces in a room model. The classical laws of geometrical acoustics are such that for the purposes of calculating how much energy is reflected; all surfaces are considered to be infinitely large in comparison to the wavelength. For practical room models surfaces are not infinitely large and ODEON is, to some degree, able to take into account the limited size of surfaces in calculations – using the *Reflection Based Scattering method*. Still ODEON is a high frequency model so surfaces should as far as possible be kept as large as possible – don't use more surfaces than needed in order to mimic the geometry, modeling a lot of small surfaces to achieve high geometrical fidelity is likely to produce worse rather than better results – and its likely to increase calculation time. It is difficult to put concrete limits on the size of surfaces which should be used; there will always be a need for small surfaces to fill in awkward corners of the geometry, but a rule of thumb may be to keep surface dimensions larger than one wavelength at the mid-frequencies (one wavelength at 1000 Hz is approximately 0.34 metres). A typical model of a concert hall can typically be modeled with a surface count of say 100 to 1000 surfaces.

3.1.3 Curved surfaces

All surfaces in ODEON must be (almost) plane; so curved surfaces have to be approximated by dividing them into plane sections. The question of how finely to subdivide depends on the type of curved surface and how important the surface is.

Convex curves naturally disperse sound energy, so if the surface is in an exposed position (e.g. the end of a balcony near the stage), one should avoid for example simply replacing a quarter circle with a single plane at 45, which might then act like a reflector.

Concave curves naturally focus sound energy, and since focussing is a fault we wish to model, we must try to arrange that it be preserved. However, this does not mean that a large number of subdivisions are the solution. Using many surfaces in the model will:

- Make the model visually complex, and increase the probability of errors in the model, typically small leaks may become a problem.
- Not combine with the image source theory used for the early reflections (point sources).
- Increase the calculation time

Subdivisions about every 10° to 30° will probably be adequate to reproduce focussing trends, without excessive numbers of surfaces, thus walls in a cylindrical room may be modeled from 12 to 36 surfaces. A cylindrical column which disperses energy may probably be modeled from, say 6 to 8 surfaces.

3.1.4 What to model?

How to model an audience area?

Modeling each step between the rows in an audience area is not recommended, the audience area can be simplified a lot without compromising the quality of the results – in fact using one of the suggestions methods below is likely to produce better results.

Audience A) Modeling the floor surfaces

- a) Define the floor area below the audience.
- b) Assign appropriate 'absorption material' e.g. Odeon material 901,902,903 or 904.
- c) Assign a high scattering coefficient of 0.7 to this area.
- d) Place the receivers some 1.2 metres above the floor.

Audience B) Modeling the audience as boxes

Model the audience area as 'audience boxes' with a height of approximately 0.8 metres above the audience floor.

- b) Assign appropriate 'absorption material' e.g. Odeon material 901,902,903 or 904.
- c) Assign a high scattering coefficient of 0.7 to the surfaces of the 'audience box'.
- d) Position the receivers some 0.4 metres above the modeled 'audience box'.

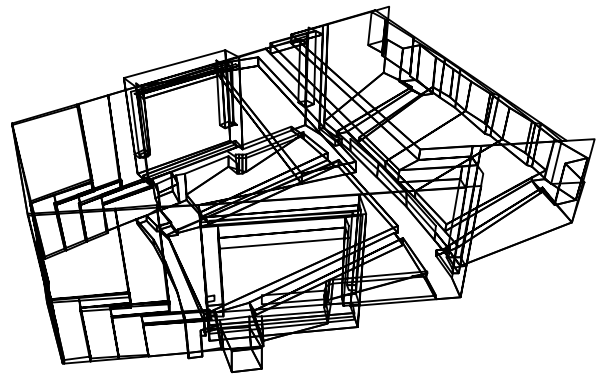
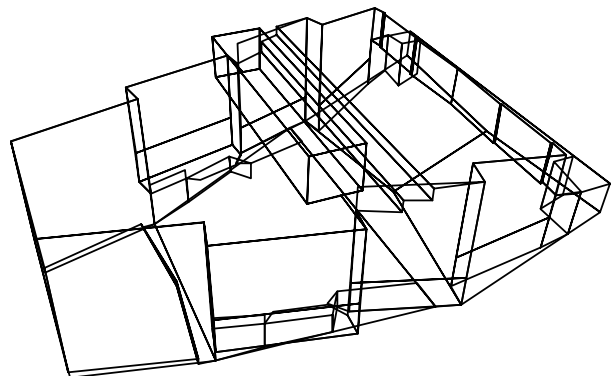

Experiences from tests with first approach are positive and it is far the easiest to model. The 'Elmia' hall is an example of this. A potential drawback of modeling the audience area as a box is that it removes volume from the room, which is may be a problem in rooms with low ceiling height /volume.

How to model the podium on stage?

Same guideline as for the audience area goes here. Rather than modeling each step of the podium on stage, the podium can be simplified into a few sloped surfaces.

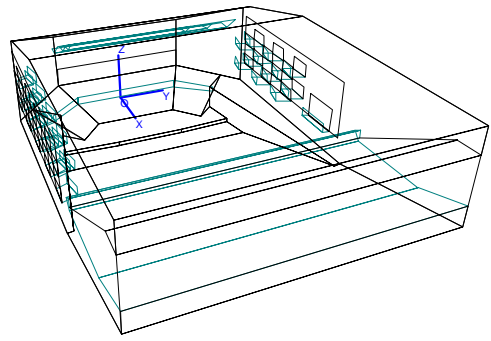

Should furniture such as tables, chairs and shelves be included in a model of an office?

If a table plate is close to a source or receiver point, then it is likely to produce a strong specular reflection at the receiver, so if this is the case then it should be included. Furniture such as shelves and screens in large office environments, which subdivides the room – breaking up long reflection paths and introducing extra absorption and scattering should neither be omitted.

Furniture at more distant locations in the room, which does not produce any strong early reflections to the receiver can be greatly simplified or even omitted from the model as long as the extra absorption and scattering produced by that furniture is somehow included on other surfaces in the same regions of the room.

How to model a table with chairs?

An easy way to model a table with chairs around it is to model a box, making its side surfaces semi-transparent by setting the transparency coefficients to values greater than zero (e.g. 0.5) in the Materials list inside Odeon.

If the furniture is basically plane surfaces, then low scattering coefficients should be assigned just like for any other type of plane surface, provided that Reflection Based Scatter is activated. Only if major details e.g. computers and computer screens are omitted in the model should the scattering coefficients be increased to e.g. 0.5.

It may be acceptable to model the geometry in more detail, but the above method seems to work well and makes the modeling process faster.

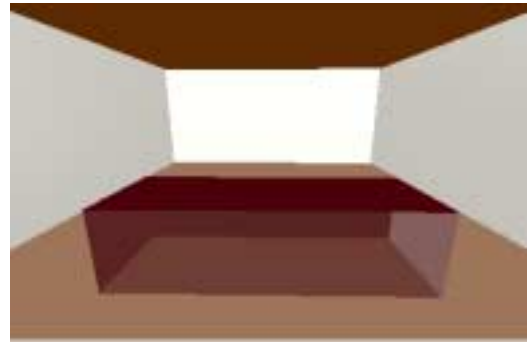

Orientation of surfaces – does tilt of a surface have any significance on room acoustics?

Small changes to the orientation of surfaces can indeed cause dramatic changes. Making dominant surfaces slightly off-angle can cause extra scattering in the room almost as if extra scattering had been assigned to the surfaces in the room. A classical example on this is the box shaped room where a flutter echo can be removed, changing the angle of a surface by a degree or two.

3.2 Modeling rooms by typing it into a text file

3.2.1 The ODEON .Par modeling format /language

Geometry models can be made using the parametric modeling language, which is built-in to ODEON. The model data are typed into a text file given the file extension .Par using the modeling language described below. You may use the supplied editor OdwEdit to create and edit your text files. The ODEON modeling format is not case sensitive, so upper and lower case letters can be used as desired.

A simple modeling example

At its simplest (but not fastest), a floor with the dimensions 4 x 4 metres can be defined as follows (using the reserved keywords *Pt* and *Surf* in order to define points and surfaces):

```
FloorSurface.Par
###
Pt      1      0      0      0
Pt      2      4      0      0
Pt      3      4      4      0
Pt      4      0      4      0
Surf    1      floor
        1      2      3      4
###
```

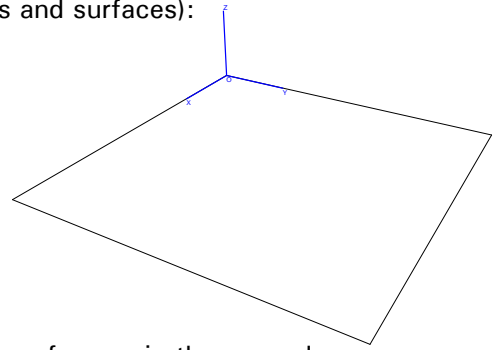

One may choose to model the room point-by-point and surface-by-surface as in the example above, however for many geometries it will be an advantage to use parameters to describe basic dimensions in the rooms and to use high level statements to describe multiple points and surfaces in a fast and flexible way. Before starting your first large modeling project it is a very good idea to read through chapter 3 or at least skim it - it will pay off in the end.

Another way to learn about the modeling language is to study the examples, which are installed in the \Odw.\rooms\manual examples directory along with the Odeon program – open the room(s) in Odeon, then click the Open the Odeon Editor icon on the toolbar in order to study the room.

Components in the modeling format

The basic function of the modeling format is to allow modeling of surfaces in room geometries. The surfaces can be modeled point-by-point, surface-by-surface, however it is also possible to make use of symmetry and to create repeated features in a room such as columns, using programmatically loops, finally it is possible to use hybrid functions, which creates points as well as surfaces in terms of shapes such as boxes, cylinder and domes.

Constants, variables and counters

Constants and variables can be defined and used in the file format. It is a good habit to use constants whenever a value is used more than a few times in a file, this reduces typing errors and it also makes it easier to make general changes to a geometry such as changing the height of a room.

Mathematical expressions

Mathematical expressions can be used to express any real or integer number in the file e.g. coordinates, constants, variables, counters, point numbers, surface numbers etc. If you use a value that is not an integer value to describe a point- or surface number being is an integer, then that value will be rounded to the nearest integer value.

You may describe coordinates using mathematical expression like:

$$\text{Length} * \text{Sin}(\text{PI}/4)$$

where *Length* is a user-defined constant or variable. Mathematical expressions may not contain any SPACE or TAB (tabulation) characters. To get a complete overview of the mathematical functions available, please refer to appendix A.

Points

A point is made up from an unique point number and its X,Y and Z coordinates, Use the *Pt*, *MPt* and *CountPt* statements to define points. Points can also be defined implicitly, using one of the hybrid statements.

Surfaces

A surface is made up from a unique number, an optional descriptive text and a number of points connected to one another. To define surfaces use the *Surf*, *MSurf*, *CountSurf*, *ElevSurf*, *ElevSurf2* and *RevSurf* statements. Surfaces may also be defined implicitly using the hybrid statements.

Hybrid statements

Hybrid statements are; *Box*, *Cylinder*, *Cylinder2*, *Cone*, *Dome*, *Dome2* and *ElevSurf*. The hybrid statements create the points and surfaces needed to model the specified shape. The points and surfaces created must always have unique numbers.

Coordinate manipulation functions

A set of functions for coordinate manipulation (and surfaces made up from coordinates) is included. This includes rotation around the various axes, scaling and translation. These functions are needed in order to insert shapes defined by the hybrid statements in the geometry with the correct position and orientation.

Comments and empty lines

Lines containing comments, and empty lines, may be inserted anywhere in the file, as long as they do not come between data items, which should occur on one line. Comment lines must begin with a colon (:), a semicolon (;), a slash (/) or an asterisk (*). The semicolon can also terminate a non-comment line, allowing a non-comment line to be terminated with a comment.

A series of comment lines are started with a '{' and ended with a '}', both as the first sign on a line.

Reserved keywords, predefined counters and constants

The following keywords are reserved by ODEON and has a special meaning in the parametric modeling language:

Constant and variable statements

Const, Var

Point statements

Pt, MPt, CountPt

Point lists statements

Plist0 – Plist9

ResetPlist0 – ResetPlist9

PlistA, PlistB

Surface statements

Surf, MSurf, RevSurf, CountSurf, ElevSurf, ElevSurf2

Hybrid statements

Box, Cylinder, Cylinder2, Cone, Dome, Dome2

Loop statements

For..End,

Transformation statements

Mreset, MPop, MScale, MTranslate, MRotateX, MRotateY, MRotateZ

(and for compatibility with earlier releases of ODEON: *Scale, UCS*)

Predefined constants

PI = 3,14159265358979312

Predefined variables

NumbOffset, ONVert

Predefined Counters

PtCounter

Coordinate system definition statements

Unit, CoordSys

Debugging Facilities

DebugIsOn, Debug

Defining constants

Constants must follow the syntax:

Const<Name><Value>

where value is a mathematical expression, which may be based on numbers or constants and variables that has already been defined.

Example 1:

Const CeilingHeight 3.4

Example 2:

Const FloorLevel 1
Const CeilingHeight FloorLevel+3

Example 3:

Const FloorHeight 1
Const Length 6
*Const CeilingHeight FloorLevel+Length*TanD(30)*

Defining and reassigning variables

The definition of variables must follow the syntax:

Var <Name><OptionalValue>

Example 1; defining the variable *FloorLevel*:

Var FloorLevel

Example 2; defining the variable *FloorLevel* and assigning the initial value 0:

Var FloorLevel 0

Example 3; reassigning a variable /adding 1 metre to the *FloorLevel*:

FloorLevel FloorLevel+1

Remark: The predefined variable *NumbOffset* may be used like any other variable, but has a special meaning because it offsets point and surface numbering. This variable is useful if copying a part of a geometry from another geometry file, it is also useful in connection with the *for..end* statements.

Auto can also be assigned to *NumbOffset*, in doing so Odeon will automatically increment the value of *NumbOffset* to be greater than any point and surface number previously defined. This has the advantage that repeated point and surface numbers can easily be avoided without having to keep track on the numbers used - the drawback is that slight changes in the geometry file may change numbers on many subsequent surfaces, ruining the relationship between surface numbers and the material assigned to that surface inside the Odeon program. The *Auto* option is very useful in combination with loop constructions (see description of the *for..end* constructs later on). Typing *PtAbsRef* after the value assigned to *NumbOffset* forces absolute number references for points while using the specified offset on the numbers of surfaces – this is explained later.

Example on the use of *NumbOffset*; creating surface 101 containing the points 101 to 104 and surface 201 containing the points 201 to 204:

```

NumbOffset.Par
###
NumbOffset 100
Pt 1 0 -1 0
Pt 2 0 1 0
Pt 3 1 1 0
Pt 4 1 -1 0

Surf 1 A surface
1 2 3 4

NumbOffset NumbOffset+100
Pt 1 0 -1 1
Pt 2 0 1 1
Pt 3 1 1 1
Pt 4 1 -1 1
Surf 1 Another surface
1 2 3 4
###

```

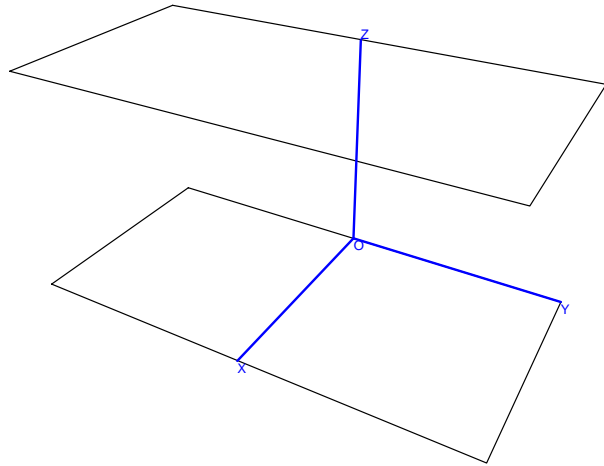

Example creating point 1–4 and surface 1, setting *NumbOffset* to *Auto*, then creating Point 5-8 and surface 5:

```

###
Pt 1 0 -1 0
Pt 2 0 1 0
Pt 3 1 1 0
Pt 4 1 -1 0

Surf 1 A surface
1 2 3 4

NumbOffset Auto
Pt 1 0 -1 1
Pt 2 0 1 1
Pt 3 1 1 1
Pt 4 1 -1 1
Surf 1 Another surface
1 2 3 4
###

```

Defining a point using the *Pt* statement

Use the *Pt* statement to define a single point. The syntax must be as follows:

Pt <Point Number><XMathExpression><YMathExpression><ZMathExpression>

Example defining point number 100 in $(x,y,z) = (1,1,1)$:

```
Pt 100 1 1 1
```

Hint! Point number and coordinates can be written using mathematical expressions, allowing greater flexibility and reusability.

Parametric modeling - defining multiple points

Use the *MPt* statement to define a series of points, which is typically used in connection with the *ElevSurf* or *ElevSurf2* Statement. The syntax must be as follows:

```

MPt <Number> <NumberOfPoints>
<XMathExpression1><YMathExpression1><ZMathExpression1>
<XMathExpression2><YMathExpression2><ZMathExpression2>
....NumberOfPoints lines each defining a point in the multi point sequence, should follow the MPt statement.

```

<Number>

A unique number from 1 to 2.147.483647 for identification of the first point in that multi point sequence.

<NumberOfPoints>

The number of points defined by this multipoint statement - if the number is 3, then 3 lines should follow, each describing the coordinates of a point.

Example 1; defining point number 100 in (x,y,z) = (1,1,1) and point number 101 in (x,y,z) = (2,2,2)

```
MPt 100 2
  1.0 1.0 1.0
  2.0 2.0 2.0
```

As a special option for multi points, it is possible to repeat a coordinate used in the previous point of that multipoint sequence or to repeat the coordinate while adding or subtracting a value from that point:

Example 2; defining point number 100 in (x,y,z) = (1,1,1) and point number 101 in (x,y,z) = (1,2,0)

```
MPt 100 2
  1 1 1
  = +=1 -=1
```

Defining a series of points using the CountPt statement

The *CountPt* statement must follow the syntax:

CountPt<FirstPointNo><MaxCount><XMathExpression><YMathExpression><ZMathExpression>

Use the *CountPt* statement to define a series of points using a counter. This statement makes use of the predefined counter *PtCounter*, which will run from 0 to *MaxCount-1*, producing the points with the numbers *FirstPointNo* to *FirstPointNo+MaxCount-1*. Use the *PtCounter* in the expression of the x,y and z coordinates to create the desired differences between the 'count points'.

Example; defining 7 points on a circle with a radius of 10 at Z=0 metres:

```
CountPt 100 6+1 10*cosD((PtCounter)*360/6) 10*sinD((PtCounter)*360/6) 0
```

Note! First and last point in this series of 'count points' are equal (redundant). This will typically be desirable when using the *CountPt* statement along with *RevSurf* statement.

Defining a single surface using the Surf statement

A *Surf* surface is divided into two lines and must follow the syntax:

Surf <SurfaceNumber><Optional Description>
<ListOfPointNumbers>

The *Surf* statement is used to define a single surface (in some situations with symmetry, two surfaces). The *Surf* statement is constructed from two lines, one identifying the surface by a number and an optional name and another with a list of corner numbers.

<SurfaceNumber>

A unique number from 1 to 2.147.483647 for identification of the surface. Using the same number, but with negative sign defines the surface and its mirrored counter part in the XZ-plane (Y = 0). The surface number may be defined using mathematical expressions.

<Optional Description>

A string displayed and printed for easy identification of the surface. Could be something like 'Main floor'.

<ListOfPointNumbers>

Each surface may be bounded by between 3 and 500 corners, which all lie in a plane. Corner numbers refer to the corners, which must have been defined (e.g. using the *Pt* or *CountPt* statements) before using the surface statement. The order of listing must be as obtained by travelling around the surface's

edge (in either direction). The list of corners must be on the same line. A room may contain up to 10000 surfaces.

Example 1, surface made from point 1, 2, 3, 4:

```
Surf      100    floor
 1         2     3     4
```

Example 2, surface made from point 1,2,10,11,12,13,14,4,5:

```
Surf      200    Ceiling
 1         2     10>14  4     5
```

If there is a need to programmatically build a list of points this can be done using the *PList* and *ResetPList* statements.

Building lists of points using PList and ResetPList

The *PList* and *ResetPList* statements are used in special cases together with the *Surf* statement. Twelve lists are predefined namely *PList0* to *PList9* (and *PListA* and *PListB* which are handled automatically by ODEON). The *PList* statements allows to programmatically construct a list of points e.g. a list like:

```
100 110 120 130 140 150 160 170 180 190 200
```

this can be done using a *for..end* construct in the following way (adding a point number at a time):

```
for MyCounter 0 10
  PList0      100+MyCounter*10
end
```

It is also possible to add a number of points to a point list, e.g. another *PList* to a *PList*. In the following example *PList1* is assigned the points 100 110 120 130 140 150 160 170 180 190 200 10 11 12 13 15):

```
PList1 PList0 10>13 15
```

A point list can be referenced in the following way (adding point 1 before and 2 after the list in this example):

```
Surf Test_surface
 1      PList0  2
```

To reset the list use the statement (list 0 used in this example):

```
ResetPList0
```

Multi Surface - MSurf

The multi surface *MSurf* is essentially just a variant of the *Surf* statement. Instead of typing one header line (e.g. *Surf 1 A surface name*) for each surface, the header can be shared by multiple surfaces.

```
MSurf <SurfaceNumber><NumberOfSurfaces><Optional Description>
<ListOfPointNumbers1>
<ListOfPointNumbers2>
<ListOfPointNumbers3>
.....<NumberOfSurfaces> lines with lists of points describing each surface.
```

<SurfaceNumber>

A unique number from 1 to 2.147.483647 for identification of the surface. Using the same number, but with a negative sign defines the surface and its mirrored counter part in the XZ-plane (Y = 0). The surface number may be defined using mathematical expressions.

<NumberOfSurfaces>

The number of surfaces in the surfaces in the *MSurf*.

<Optional Description>

A string displayed and printed for easy identification of the surface. Could be something like *Main floor*.

Example on multi surface, containing 5 sub-surfaces:

```
MSurf 1 5 Steps on a stair
5544>5534 5112>5122
5111>5101 5212>5222
5211>5201 5312>5322
5311>5301 5412>5422
5411>5401 5512>5522
```

Elevation surface

Use The *ElevSurf* statement to define a series of vertical surfaces from a series of perimeter points plus an elevation height. The perimeter points are typically defined using the *MPt* statement. The syntax of *ElevSurf* is:

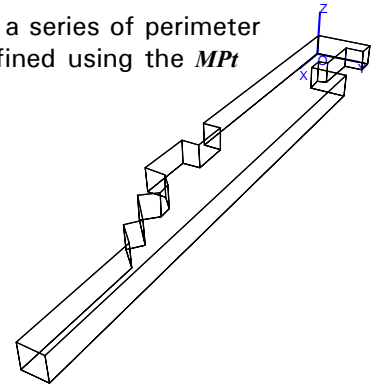

```
ElevSurf
FirstSurfaceNumber<>FirstPointNumber<>SectionsInElevSurf<>Height<>Optional name<>
```

Example on use of the *MPt* and *ElevSurf* statements:

First the perimeter points (point 1 to 23) at the floor level of an office environment are described using the *MPt* statement. Then the elevation surface is created from these points, creating the perimeter walls of the office with a constant height of 2.7 metres. Finally the floor and ceiling is created using the *Surf* statement.

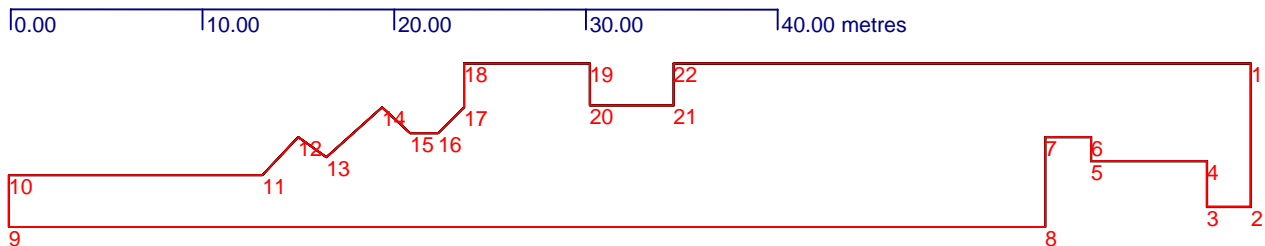

Perimeter points at the floor level

Example file: *MPt and ElevSurf.Par*

Demonstrates the use of *MPt* (multi point), *Surf* (Surface) and *ElevSurf* (Elevation surface) statements. In this example the X-coordinates are made in absolute values whereas the Y-coordinates in most cases are in- or de-decreased using the = + or = - options

To create a closed *ElevSurf* (that is, the first wall joins the last wall) first and last point in the series of points handled to the *ElevSurf* must be identical - in this example, point 1 and point 23 are identical. If an elevation surface has 22 surfaces, then 23 points must be made available to the *ElevSurf* as in this example.

```
###
MPt 1 23
0 0 0
= 7.48 =
2.3 = =
= -2.38 =
8.35 = =
= -1.26 =
10.76 = =
= +4.64 =
64.78 = =
= -2.68 =
51.52 = =
49.62 = -2.02 =
48.22 = +1.1 =
45.3 = -2.68 =
```

```

43.85 =+1.45 =
42.40 ==
40.98 =-1.45 =
= 0 =
34.5 ==
==2.1 =
30.13 ==
=-2.13 =
0 0 0

```

ElevSurf 1 1 22 2.7 walls

Surf 200 Floor
1>22

Surf 201 Ceiling
24>24+22-1
###

Elevation surface 2

Use the *ElevSurf2* statement to define a series of vertical surfaces from a series of perimeter points plus an elevation height. The perimeter points are typically defined using the *MPt* statement. The syntax of *ElevSurf2* is:

```
ElevSurf2 <FirstSurfaceNumber><FirstPointNumber><SectionsInElevSurf><Height><T/B/N><Optional name>
```

The *ElevSurf2* only differs from *ElevSurf* in that a top and bottom surface may be specified (the T/B/N option).

<FirstSurfaceNumber>

A unique number from 1 to 2.147.483647 for identification of the first surface in the *ElevSurf2* surface. Using the same number, but with negative sign, defines the surface and its mirrored counter part in the XZ-plane ($Y = 0$).

<FirstPointNumber>

First point number in the floor perimeter. The floor points are typically *MPt* statement. See example below.

<SectionsInElevSurf>
>

The number of surfaces to be created by the *ElevSurf2* statement. If creating a cylinder a number between 16 and 24 is suggested (if it's a column only use six to eight surfaces).

<Height>

Height is oriented in the Z-direction in the figure below.

<T/B/N>

The T/B/N parameter specifies whether the *ElevSurf2* should have a top and /or a bottom. The options are T, B, TB and N (for none). If Top or bottom may only be included if all of the points in the floor in the elevation surface are in the same plane.

Example on use of the *MPt* and *ElevSurf2* statements. First the perimeter points (point 1 to 23) at the floor level of an office environment is described using the *MPt* statement. Then the elevation surface is created from these points, creating the perimeter walls of the office with a constant height of 2.7 metres.

Perimeter points at the floor level.

Room created using the *MPt* and *Elevsurf2* statements.
Demonstrates the use of

MPt (multi point) and *ElevSurf2* (Elevation surface) statements

In this example the X-coordinates are made in absolute values whereas the Y-coordinates in most cases are in- or de-created using the = + or = - options

To create a closed *ElevSurf2* (that is, the first wall joins the last wall) first and last point in the series of points handled to the *ElevSurf2* must be identical - in this example, point 1 and point 23 are identical.

If an elevation surface has 22 surfaces then 23 points must be made available to the *ElevSurf2* as in this example.

```
###
MPt 1 23
0 0 0
= 7.48 =
2.3 = =
= -2.38 =
8.35 = =
= -1.26 =
10.76 = =
= +4.64 =
64.78 = =
= -2.68 =
51.52 = =
49.62 = -2.02 =
48.22 = +1.1 =
45.3 = -2.68 =
43.85 = +1.45 =
42.40 = =
40.98 = -1.45 =
= 0 =
34.5 = =
= 2.1 =
30.13 = =
= -2.13 =
0 0 0

ElevSurf2 1 1 22 2.7 TB walls
###
```

Defining a number of surfaces using the CountSurf statement

The *CountSurf* is mostly here for backwards compatibility. In most cases it will be easier to use the *Surf* statement along with a *for...end* loop.

A Counter surface is divided on two lines and must follow the syntax:

```
CountSurf <First Surface Number><NumberOfSurfaces><Optional name>
          <ListOfPointNumbers>
```

<FirstSurfaceNumber>

A unique number from 1 to 2.147.483647 for identification of the surface. Using the same number, but with negative sign defines the surface and its mirrored counterpart in the XZ-plane (Y = 0). A *CountSurf* will take up several surfaces numbers, which must all be unique.

<NumberOfSurfaces>

The number of surfaces to be created by the *CountSurf* call.

<Optional name>

Optional user defined name for easy identification of the surface, e.g. 'Beam'.

<ListOfPointNumbers>

Each surface may be bounded by between 3 and 50 corners, which all lie in a plane. Corner numbers refer to the corners, which must have been defined (e.g. using the *Pt* or *CountPt* statement) before using the surface statement. The order of listing must be as obtained by travelling around the surface's edge (in either direction). The list of corners must be on the same line. A room may contain up to 10000 surfaces.

Example:

```
CountSurf 1000 5 Beam in ceiling
          1000 1100 1200 1300
```

will produce five surfaces, the first containing the numbers given in the *ListOfPointNumbers* the next surface with 1 added to all the corners in the list etc.. Of course all the points referred to need to be defined, typically this is done using a *CountPt* definition for each of the corners referred to in the corner list of the *CountSurf* statement. In the above example the points 1000-1004, 1100-1104, 1200-1204 and 1300-1304 need to be defined.

Sample room files:

```
Beams.Par
BeamBox.Par
BeamBoxWithWindows.Par
```

Revolution surface RevSurf

RevSurf must follow the syntax:

```
RevSurf <FirstSurfaceNumber><CurveStart1><CurveStart2><SectionsInRevSurf><Optional name>
```

The *RevSurf* command is typically used together with two *CountPt* statements to create a revolution surface using two 'curves' of points. The curves must contain the same number of points. The *RevSurf* command will always create a number of surfaces each built from four points.

<FirstSurfaceNumber>

A unique number from 1 to 2.147.483.647 for identification of first surface in the revolution surface. Using the same number, but with negative sign, defines the surface and its mirrored counter part in the XZ-plane ($Y = 0$).

<CurveStart1>

First point number in the first revolution curve. The 'curve of points' is typically created using the *CountPt* statement and the curve must contain one more point than number of sections in the *RevSurf*.

<CurveStart2>

First point number in the second revolution curve. The curve of points is typically created using the *CountPt* statement and the curve must contain one more point than the number of sections in the *RevSurf*. The second curve must always contain the same number of points as the first curve.

<SectionsInRevSurf>

The number of surfaces to be created by the *RevSurf* statement. If creating a cylinder a number between 12 and 24 is suggested. Although it is easy to create many surfaces in a revolution surface, too many small surfaces should be avoided. If the *FirstSurfaceNumber* is 100 and *SectionsInRevSurf* is 3, surface 100, 101 and 102 will be created.

<Optional name>

Optional user defined name for easy identification of the surface, e.g. 'cylindric wall'.

Example:

```
RevSurf 1000 100 200 6 Cylinder
```

creates a revolution surface divided in 6 surfaces (surface 1000 - 1005). This call requires two curves of each 6 + 1 points to be defined, namely point 100 to 106 and point 200 to 206. If the two curves of points define corners in the lower and upper edge of a cylinder, a cylinder of 6 sections is created (see example room: *RevSurfCylinder.Par*)

Loops using the FOR...END construct

The *For* statement must follow the syntax:

```
For <CounterName><CountFrom><CountTo>
```

<CounterName>

Name of counter to be used by the *For* statement. The counter is automatically defined by the *For* statement and becomes undefined when the loop finishes. The counter can be referenced within the *for..end* loop as an ordinary constant or variable if desired so.

<CountFrom>

First value the counter takes. The *CountFrom* value is considered an integer value. If the number entered here is not an integer, it will be rounded to the nearest integer value.

<CountTo>

Last value the counter takes. The *CountTo* value must be greater or equal to the *CountFrom* value. The *For* statement will take *CountTo-CountFrom+1* loops. The *CountTo* value is considered an integer value, if the number entered here is not an integer, it will be rounded to the nearest integer value.

The following example will produce the points 1 to 5 with the X-coordinates 5, 10, 15, 20 and 25 metres, while the counter (*MyCounter*) loops through the values 1 to 5:

```
For MyCounter 1 5
Pt MyCounter MyCounter*5 0 0
end
```

When using *For..End* constructs it should be remembered that point and surface number must be unique. This is easily obtained by incrementing the special variable *NumbOffset* appropriately in each loop. An example on this kind of numbering can be found in the sample file *ForColumnRoom.Par* where *NumbOffset* is incremented by eight in each loop (each time a new column, which contains 4 surfaces and 8 points, is created).

Sample room files:
ForRotunde.Par
BoxColumnRoom.Par

Unit

The *Unit* statement is used if you wish to model in a unit different from metres. The unit used in the parametric file is by default assumed to be metres, however if you prefer to model in another unit, this is possible using the *Unit* statement. Check the example below.

Example, modeling in Inches:
Unit Inches

You may choose your unit among the following predefined:
Metres, Centimetres, Millimetres, Inches, Feets and Yards

Or if you need a different unit, simply type the scaling factor from your unit into metres, e.g.
Unit Inches

corresponds to:
Unit 0.0254

The *Unit* statement may be used more than once in the same .par file:

```
###
Unit Inches
;e.g. imported model data in inches
.....model data.....
.....model data.....
Unit 0.57634
; model data measured on a paper drawing which appeared in an odd unit
.....model data.....
.....model data.....
Unit Metres
; model data appended in the Odeon editor / modeling environment
; it is most paratical to use metres as the unit when modeling in the Odeon ;environment - then coordinate values will be
the same in the Editor as inside the 3DView in Odeon
.....model data.....
.....model data.....
###
```

CoordSys statement

The *CoordSys* statement is used if you wish to redefine the orientation of the coordinate system in which the geometry was modeled. The statement is typically used if the geometry was 'by accident' modeled in an orientation different from the one assumed by ODEON or if it was imported from a CAD drawing where the orientation may also be different. To obtain the easiest operation inside ODEON the following orientation should be used (using a concert hall as the example):

- X-axis pointing towards the audience
- Y-axis pointing to the right as seen from the audience
- Z-axis pointing upwards

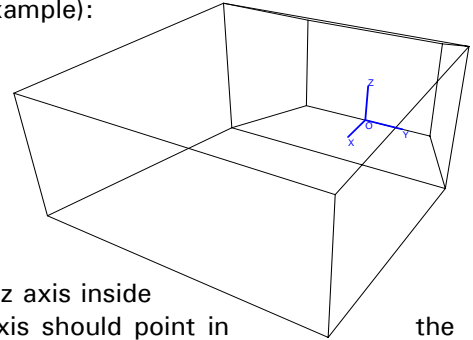

The syntax is:

```
CoordSys <X> <Y> <Z>
```

where X, Y, Z indicate which axis should be used as the x, y and z axis inside ODEON. X, Y and Z may also have a sign to indicate that the axis should point in the opposite direction.

Example 1, the default orientation (which is assumed by ODEON if the *CoordSys* statement is not used in the geometry file):

```
CoordSys X Y Z
```

Example 2, changing the direction of the X-axis:

```
CoordSys -X Y Z
```

Example 3, Swapping the X and the Z-axis

```
CoordSys Z Y X
```

Example 4, The *CoordSys* statement may be used more than once in the same .par file:

```
###  
CoordSys -X Y Z  
;e.g. if the X axis was inverted in imported model data  
.....model data.....  
.....model data.....  
;resetting the coordinate system to the default  
CoordSys X Y Z  
; model data appended in the Odeon editor / modeling environment  
;it is most practical if using the default Coordinate system when modeling in the Odeon ;environment - then coordinate  
system will have the same orientation in the Odeon editor as well as in the 3DView inside Odeon.  
.....model data.....  
.....model data.....  
###
```

User coordinate system

The *UCS* command is mostly there for compatibility with previous versions of ODEON – the coordinate manipulation functions *MTranslate*, *MRotateX*, *MRotateY*, *MRotateZ*, *MScale*, *MPop* and *MReset* included from version 4.21 allow far more flexibility. For your own sanity it is not advisable to mix the two methods.

The *UCS* command must follow the syntax:

```
UCS <TranslateX><TranslateY><TranslateZ><RotateZ>
```

The *UCS* command is used to create a User Coordinate System, with its own X, Y and Z translation. It also allows a rotation around the Z-axis (specified in degrees). All point definitions made after a *UCS* call will be created in the specified coordinate system. The default coordinate system is defined as:

```
UCS 1 1 1 0
```

The *UCS* command corresponds to:

```
MReset  
MTranslate <TranslateX><TranslateY><TranslateZ>  
MrotateZ <RotateZ>
```

If the *UCS* command doesn't fulfil your needs for coordinate manipulation you may use the matrix manipulation family *MTranslate*, *MRotateX*, *MRotateY*, *MRotateZ*, *MScale*, *MPop* and *MReset*.

Scale

The *Scale* command is mostly there for compatibility with previous versions of ODEON – the coordinate manipulation functions *MTranslate*, *MRotateX*, *MRotateY*, *MRotateZ*, *MScale*, *MPop* and *MReset* included from version 4.21 allow far more flexibility. For your own sanity it is not advisable to mix the two methods.

The *Scale* command must follow the syntaks:

```
Scale <ScaleX><ScaleY><ScaleZ>
```

The *scale* command will multiply /scale all the points generated after the *scale* call, using the specified x,y and z-scale. The default setting is:

```
Scale 1 1 1
```

The *Scale* command evokes scaling of coordinates after all other coordinate manipulation is carried out. If you should need more advanced scaling options please use the *MScale* option.

Coordinate manipulations – the M-family

Advanced coordinate manipulation can be carried out using matrix manipulation. The coordinate manipulation functions, which is essential to the use of hybrid statements (*Box*, *Cylinder*, etc.) is implemented as the following functions:

```
MTranslate <TranslateX><TranslateY><TranslateZ>  
MrotateX <Rotation angle>  
MrotateY <Rotation angle>  
MrotateZ <Rotation angle>  
MScale <ScaleX><ScaleY><ScaleZ>  
MPop  
MReset
```

The manipulations carried out by the M-family are cumulative. This means that you can specify more than one operation to be carried out, e.g. first rotate 90° around the Z-axis, then rotate 90° around the Y-axis and finally translate 10 metres upwards. The following example shows these operations carried out on a cylinder shell (the *Cylinder* statement is described later):

```
Manipulating a cylinder.Par  
###  
MrotateZ 90  
MrotateY 90  
MTranslate 0 0 10  
Cylinder 1 20 5 180 10  
###
```

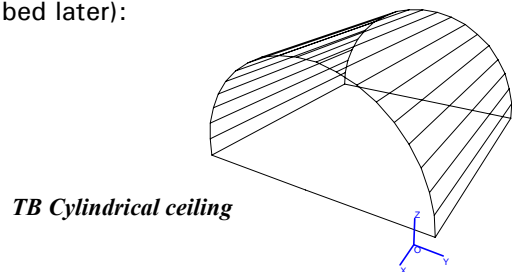

The transformation commands to be carried out must always be stated before the points /geometry on which they should work is created. To reset all previous coordinate manipulations, use the *MReset* command. To reset /cancel the most resent manipulation (*MTranslate* in the example above), use the *MPop* command (which will pop the operation of the matrix stack).

Hints!

The order in which the coordinate manipulations are carried out is important, usually (but not necessarily always), the *MScale* commands should come first, then the *MRotate* commands and finally the *MTranslate* commands.

If you are not familiar with coordinate manipulations, it may be a good exercise to try different manipulations on the sample geometry above and load the geometry into ODEON upon each change.

Using layers in ODEON

The *Layer* statement allows dividing a geometry into separate parts, which can be displayed separately and in its own layer-colour in the 3DView, 3DOpenGL and Materials list. This makes it easier to model and investigate selected groups of surfaces. When importing geometry from a DXF file (e.g. from AutoCAD where layers are an integrated part) the layers included in that file will be preserved in the imported version of the room.

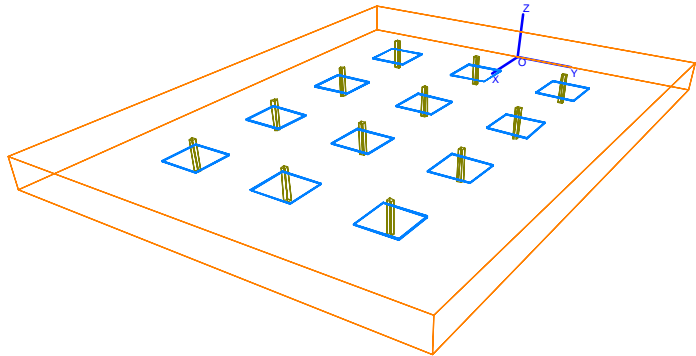

If layers have been used in a geometry, the layer can be activated or deactivated in the 3DView, 3DOpenGL and Materials list. The layers menu is activated from these windows using the Ctrl+L shortcut.

Vocabulary - what's a layer?

Layers are commonly used in CAD modeling programs such as AutoCAD in order to make complicated geometries manageable. Layers in CAD programs (and some drawing and picture editing programs) can be compared to overhead sheets (without any thickness). You define a number of layers with different names (and possibly different line colour/thickness etc.) and draw the different parts of your geometry on the different layers. The layers can be turned on or off in the CAD program allowing better overview by hiding parts of the geometry that are not relevant in a part of the 'drawing' process.

Syntax for the Layer statement:

Layer <"Layer name in quotes"> <R-intensity><G-intensity><B-intensity>

or as another option:

Layer <"Layer name in quotes"> <LayerColour>

<"Layer name in quotes">

A descriptive name, which must start and end with a quote sign (").

<R-intensity><G-intensity><B-intensity>

Three floating-point values between 0 and 1, which together is describing the colour of the layer as a Red-Green-Blue intensity. If using the Layer command Shift+Ctrl+L from within the Odeon editor, the colour intensities are set by clicking the desired colour in a dialog-box. Do note that its not advisable to choose a greyish colour as may not be visible in ODEON.

<LayerColour>

As another option the colour of the layer can be described, using one of the predefined colours *Black*, *Blue*, *Cream*, *Fuchsia*, *Gray*, *Green*, *Lime*, *Maroon*, *Navy*, *Olive*, *Purple*, *SkyBlue*, *Teal*, or *White*. The LayerColours.par example demonstrates the different colours.

The LayerStatement.par example shows how to create a geometry on three different layers.

Selected surfaces can be selected for display in the 3DView, 3DOpenGL and the Materials list.

```
BoxColumnRoom.Par
###
const L 40
const W 30
const H 3
const NumColX 4
const NumColY 3
const ColumnW 0.3
```

```

MTranslate 1/2 0 0
Layer "Walls" 1.000 0.502 0.000 ;orange colour
Box 1 1 w h tb walls in the room
MPop
: modeling the columns

for ColYCnt 1 NumColY
for ColXCnt 1 NumColX
MReset
MTranslate ColXCnt*L/(NumColX+1) w/2-ColYCnt*W/(NumColY+1) 0

NumbOffSet Auto
Layer "Columns" 0.502 0.502 0.000
Box 1 ColumnW ColumnW h n columns in the room ;olive colour
NumbOffSet Auto
MTranslate 0 0 1.2
Layer "Table plates" 0.000 0.502 1.000 ;bluish colour
Box 1 3 3 0.1 tb tables
end
end
###

```

Symmetric modeling

Symmetric rooms can be modeled, taking advantage of the ODEON convention for symmetric models. This allows generation of symmetric or semi symmetric rooms with symmetry around the XZ-plane, $Y = 0$ – symmetric modeling is always carried out in the main coordinate system, it does not take into account manipulations carried out using *UCS*, *MTranslate* etc.

Modeling a surface symmetric around the main axis' (e.g. a reflector above the stage) can be done using symmetric points. Modeling left and right walls at the same time can be done using a symmetric double surface.

Symmetric points

Surfaces symmetric around the XZ-plane, $Y = 0$ can be made using symmetric points. If defining the point:

```

Pt      2          1.0    1.0    1.0

```

in the geometry file, using the point -2 in a surface definition of the geometry file will refer to the auto generated point:

```

Pt      -2         1.0    -1.0    1.0

```

Thus the following surface definition:

```

Surf    1000 Symmetric surface
1       2       -2       -1

```

will model a surface symmetric around the XZ-plane, $Y = 0$ (e.g. an end wall or a reflector).

If the surface is completely symmetric as above then the symmetric points can also be specified using the *Mirror* word, which should be the last component in the corner list:

```

Surf    1000 Symmetric surface
1       2       Mirror

```

Note: You should not try to define the point -2 in the geometry file it is automatically generated.

Symmetric double surface

Symmetric double surfaces are pairs of surfaces symmetric around the XZ-plane, $Y = 0$ (e.g. a right and a left wall):

```

Surf    -2       Right wall/ Left wall
12     22       23       13

```

will appear as two surfaces inside the ODEON program. Thus you will have the following two surfaces (inside the ODEON program):

-2 *Right/ Left wall*

containing the symmetric points:

-12 -22 -23 -13

and the surface:

2 *Right/ Left wall*

containing the points:

12 22 23 13

as they are defined in the geometry file.

Note: You may not define surface 2, if you are using the symmetric double surface -2, because ODEON automatically generates surface number 2.

The Box statement

The *Box* statement defines a Box with or without top and bottom. The *Box* statement may typically be used for Box shaped rooms and columns. A special case of the Box statement is when one of the dimensions *Length*, *Width* or *Height* is zero; in this case only one surface is created.

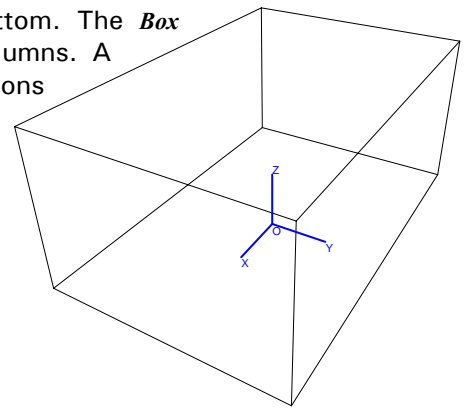

The syntax of the *Box* statement is:

Box <Number><Length><Width><Height><T/B/N><optional name>

<Number>

A unique number from 1 to 2.147.483647 for identification of the first point and surface in the *Box*. Using the same number, but with negative sign defines the box and its mirrored counterpart in the XZ-plane ($Y = 0$). A Box will take up several point- and surface numbers, which must all be unique.

<Length>

Length is oriented in the X-direction on the figure.

<Width>

Width is oriented in the Y-direction on the figure.

<Height>

Height is oriented in the Z-direction on the figure.

<T/B/N>

The *T/B/N* parameter specifies whether the *Box* should have a top and /or a bottom. The options are *T*, *B*, *TB* and *N* (for none).

Insertion point:

The insertion point of the Box is always the centre of the floor (bottom) surface.

Special cases:

If one of the dimensions *Length*, *Width* or *Height* equals zero only one surface is created.

Connection points:

The four foot-points in *Box* are stored in *PListA*

The four top-points in *Box* are stored in *PListB*

The *Box* example shown was generated with the following code:

BoxStatement.par

###

const L 6

const W 4

const H 2.7

Box 1 L W H TB Walls, floor and ceiling

###

The Cylinder statement

The *Cylinder* statement defines a cylinder shell with or without top and bottom. The statement may typically be used for modeling cylindrical room or columns. The *Cylinder2* statement, which creates a cylinder of the calotte type, will usually be preferable for modeling cylindrical ceilings.

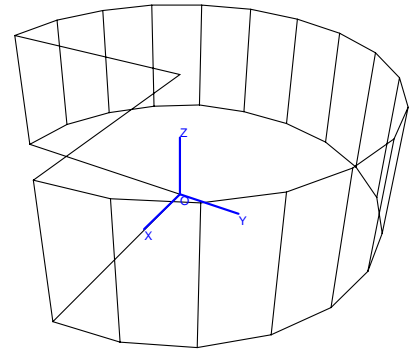

The syntax for Cylinder is:

Cylinder<Number><NumberOfSurfaces><Radius><RevAngle><Length><T/B/N><optional name>

<Number>

A unique number from 1 to 2.147.483647 for identification of the first point and surface in the *Cylinder*. Using the same number, but with negative sign defines the cylinder and its mirrored counterpart in the XZ-plane ($Y = 0$). A Cylinder will take up several point- and surface numbers, which must all, be unique.

<NumberOfSurfaces>

For a full cylindrical room (with a revolution angle of 360°), around 16 to 24 surfaces are recommended. For columns a number between 6 to 8 is recommended.

<Radius>

Radius of the cylinder must always be greater than zero.

<Revangle>

Revangle must be within the range $\pm 360^\circ$ and different from zero. If *RevAngle* is 180° , a half cylinder is generated, if its 360° a full cylinder is generated. Positive revolution angles are defined counter clockwise.

<Height>

If the height is less than zero, the orientation of the cylinder is inverted. If height equals is zero, one circular surface is generated.

Insertion point:

The insertion point of the cylinder is always the centre of the floor (bottom) surface.

Connection points:

The foot-points in *Cylinder* are stored in *PListA*

The top-points in *Cylinder* are stored in *PListB*

The example shown was generated with the following code:

```
CylinderStatement.Par
```

```
###
```

```
const N 16
```

```
const R 15
```

```
const H 10
```

```
Cylinder 1000 N R 270 H TB Cylindrical room
```

```
###
```

Hint! The cylinder can be made elliptical, using the *MScale* statement.

The Cylinder2 statement

Cylinder2 is a cylinder shell of the calotte type. Rather than specifying the radius and revolution angle, *Cylinder2* is specified in terms of the *width* and *height*. *Cylinder2* is typically used for cylindrical /curved ceilings.

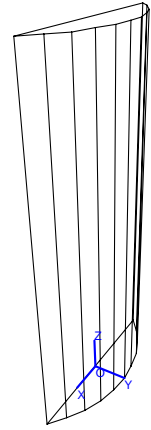

The syntax for Cylinder2 is:

Cylinder2<Number><NumberOfSurfaces><Width><Height><Length><T/B/N><optional name>

<Width>

Width is oriented in the X direction on the figure.

<Height>

Height of the cylinder shell is oriented in the Y direction on the figure and may be positive (concave shell) as well as negative (convex shell). *Height* must be different from zero and less or equal to $\frac{1}{2} * \text{Width}$.

<Length>

Length of the cylinder shell is oriented in the Z direction the figure. If *Length* is negative the orientation is inverted.

Insertion point:

The insertion point of *Cylinder2* is always foot point of the calotte floor (bottom) surface.

Connection points:

The foot-points in *Cylinder2* are stored in *PListA*

The top-points in *Cylinder2* are stored in *PListB*

The example shown was generated with the following code:

```
###  
Const N 10  
Const W 5  
Const H 1  
Const L 10  
  
Cylinder2 1 N W H L TB Cylinder calotte  
###
```

Hint! The cylinder can be made elliptical, using the *MScale* statement.

The Cone statement

The *Cone* statement models a cone. Typical use of the *Cone* statement is for modeling half cone or cone shaped ceilings.

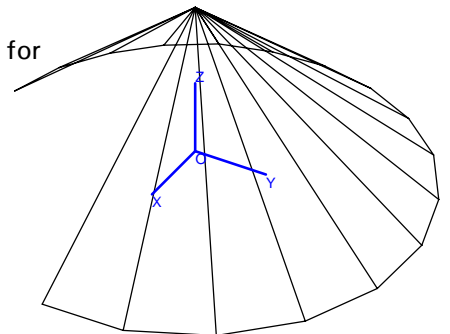

The syntax for *Cone* is:

Cone <Number><NumberOfSurfaces><Radius><RevAngle><Height><optional name>

<Number>

A unique number from 1 to 2.147.483647 for identification of the first point and surface in the Cone. Using the same number, but with negative sign defines the surface and its mirrored counterpart in the XZ-plane ($Y = 0$). A Cone will take up several point- and surface numbers, which must all be unique.

<Radius>

Radius of the Cone must always be greater than zero.

<Revangle>

Revangle must be within the range $\pm 360^\circ$ and different from zero. If *RevAngle* is 180° , a half-cone is generated, if its 360° a full cone is generated. Positive revolution angles are defined counter clockwise.

<Height>

The height must be different from zero. If the height is less than zero, the orientation of the cone is inverted. Height is oriented in the Z-direction on the figure.

The *Cone* example shown was generated with the following code:

```
###
const N 16
const R 15
const H 10

Cone 1 N R 270 H Cone shaped ceiling
###
```

Hint! The cone can be made elliptical, using the *MScale* statement.

The Dome statement

The *Dome* statement generates a full dome (half hemisphere) covering the full 90° vertical angle. In most cases the *Dome2* statement is probably better suited.

The syntax for *Dome* is:

```
Dome<Number><NumberOfSurfaces><Radius><RevAngle><optional name>
```

<Number>

A unique number from 1 to 2.147.483647 for identification of the first point and surface in the *Dome*. Using the same number, but with negative sign defines the dome and its mirrored counterpart in the XZ-plane ($Y = 0$). *Dome* will take up several point- and surface numbers, which must all be unique.

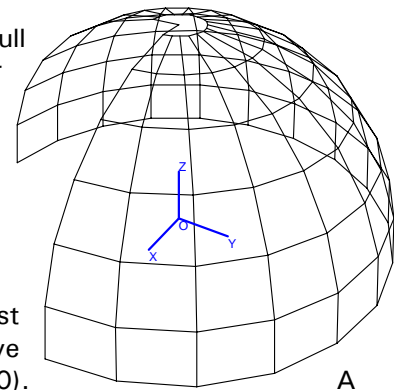

<Radius>

Radius of the *Dome* must always be greater than zero.

<Revangle>

Revangle must be within the range $\pm 360^\circ$ and different from zero. If *RevAngle* is 180° , a half *Dome* is generated, if its 360° a full *Dome* is generated. Positive revolution angles are defined counter clockwise.

Connection points:

The right side vertical points in *Dome* are stored in *PlistA*

The left side vertical points in *Dome* are stored in *PlistB*

In the special case where the revolution angle is 180° , all points are stored in *PlistA* and the number of vertical subdivisions is stored in *ONVert*.

The example shown was generated with the following code:

```
###
const N 16
const R 15

Dome 1 N R 270 This is a dome
###
```

Hint! The dome can be made elliptical, using the *MScale* statement.

The Dome2 statement

The *Dome2* statement is a Dome shell of the calotte type, where the vertical revolution angle is not necessary 90°. Rather than specifying the dome by a revolution angle, it is specified by the width and height. *Dome2* may typically be used for modeling dome shaped ceilings.

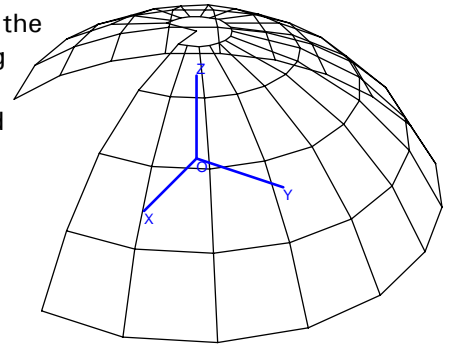

The syntax for *Dome2* is:

Dome2<Number><NumberOfSurfaces><Width><Height><RevAngle><optional name>

<Number>

A unique number from 1 to 2.147.483647 for identification of the first point and surface in the Cone. Using the same number, but with negative sign defines the surface and its mirrored counterpart in the XZ-plane ($Y = 0$). A Cone will take up several point- and surface numbers, which must all be unique.

<NumberOfSurface>

Specifies the number of surfaces in one horizontal ring of the dome, around 16 to 24 surfaces per ring is suggested. ODEON will automatically calculate the number of subdivisions in the vertical level. If the revolution angle is 180° the number is stored in the *ONVert* variable would have been 9 in the example above. The *ONVert* variable may help when connecting a *Dome2* to a *Cylinder2* in order to specify the correct number of surfaces in the cylinder.

<Width>

Width at the beginning of the dome. The width must always be greater than zero.

<Revangle>

Revangle must be within the range $\pm 360^\circ$ and different from zero. If *RevAngle* is 180°, a half-cone is generated, if its 360° a full cone is generated. Positive revolution angles are defined counter clockwise.

<Height>

The *Height* must be different from zero. If the height is less than zero, the orientation of the dome is inverted. *Height* must be different from zero and less or equal to $\frac{1}{2} * Width$.

Connection points:

The right side vertical points in *Dome2* are stored in *PlistA*

The left side vertical points in *Dome2* are stored in *PlistB*

In the special case where the revolution angle is 180°, all points are stored in *PlistA* and the number of vertical subdivisions is stored in *ONVert*.

The example shown was generated with the following code:

```
###  
Const N 16  
Const W 10  
Const H 3  
Const L 10  
  
Dome2 1 N W H 270 Dome calotte  
###
```

Hint! The cylinder can be made elliptical, using the *MScale* statement.

DebugIsOn and Debug

The debug options are useful when creating large or complicated geometries in the Odeon .par format. Using these facilities can speed up geometry loading when loaded for preview only and allow debugging of parameter values in geometry files. *DebugIsOn* is a Boolean, which can be set to *TRUE* or *FALSE*, the syntax is:

DebugIsOn < Boolean >

Typically you will insert the *DebugIsOn* flag in the beginning of the geometry file in order to investigate parameter values, when loading a geometry. When this Boolean is set to *TRUE*:

- Odeon will not prepare the geometry for calculation - as result the loading of rooms is speeded up.
- Odeon will enable debugging of parameters with the *Debug* statement.
-

The syntax for *Debug* is:

Debug <debug string>

In effect anything can be put after the *Debug* keyword, i.e. you may put a complete copy of a line in the *.par* file there. The contents following the *Debug* keyword is evaluated or if it can't be evaluated, then echo'ed directly to the debug window in Odeon when loading the geometry and it has no effect on the geometry. If *DebugIsOn* is set to *FALSE*, then debug lines are ignored. Contents in the *Debug* strings, which can not be evaluated, are displayed in quotes (").

Example: When loading the following *.par* file into ODEON:

```
###
DeBugIsOn TRUE ;debug option turned on - if DebugIsOn is set to false then Debug lines are ignored
const L 6
Debug L ;debug a single constant
const W 4
Debug const W 4
const H 2.7
Debug L W H ; Debug values of L, W and H

Box 1 L W H TB Walls, floor and ceiling
Debug Box 1 L W H TB Walls, floor and ceiling ; Debug a complete line
###
```

Odeon will create this *Debug* window as a response:

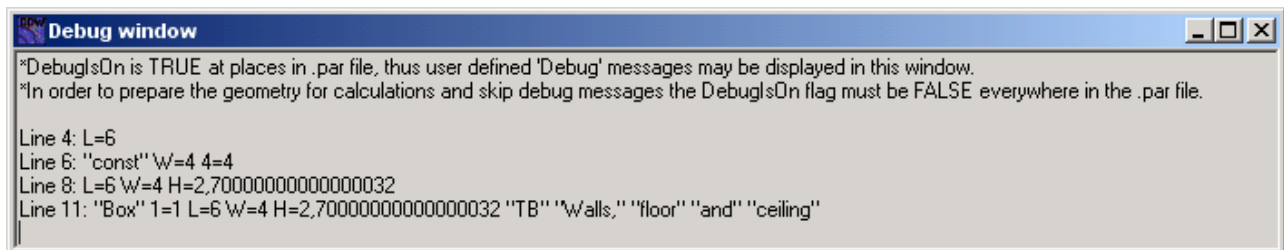

3.2.2 Creating a new .Par file - time saving hints

The golden rule when creating a *.Par* file to model a room is to think carefully before you start typing. For very simple rooms, it is not too difficult to keep track of things, but for realistically complex rooms a systematic approach is desirable. You will typically have a set of drawings, which have to be used as the basis for the ODEON model. It pays to spend quite a long time working out how the room can be simplified to a manageable number of sensibly shaped plane surfaces, sketching over the drawings. These ideas will have to be modified when you start to work out the actual coordinates, to ensure that the surfaces really are plane. Here are some ideas that may help you to create correct surface files faster:

- Exploit symmetry: If the room has an axis of symmetry, place the coordinate axis on it. Then use the 'sign'- convention for symmetric /semi symmetric modeling.
- If there are vertical walls and /or features, which repeat vertically (e.g. identical balconies), use the *CountPt*, *CountSurf*, *RevSurf* statements or indeed *For..End* constructs.
- Build the room gradually, testing the *.Par* file at each stage of growth by loading it into ODEON and have a look at the result.
- Use hybrid statements such as *Box*, *Cylinder* etc.

Where it is difficult to get surfaces to meet properly without either warping or using lots of small surfaces to fill the gaps, allow the surfaces to cut through each other a little. This will usually ensure a watertight result, and has only minor drawbacks. These are (i) the apparent surface area will be a little too big, affecting reverberation times estimated using Quick Estimate Reverberation and the room volume estimated by Global Estimate, (ii) crossing surfaces can look odd and hinder clarity in the 3D displays.

Do not try to include small geometrical details at the first attempt. If there are some large surfaces, which are basically plane but contain complex geometrical features (e.g. a coffered ceiling), model them at first as simple planes. Then first when this room has been made watertight, make the necessary alterations to the geometry file. The simplified version can also be used in the prediction exercises, to give some idea of the effect of the feature in question.

3.2.3 Examples on parametric modeling

This section will give some short examples on the modeling of rooms using the parametric modeling language of ODEON. The options in this modeling format are many, ranging from typing the model number by number, to dedicated programming. This section will try to give an idea on how to use the language and its keywords. In the default room directory created at the installation of ODEON you may find several other examples on the .Par format.

Four ways to model a box

These examples show four ways to model a box shaped room; using plain numbers, using constants, using constants plus symmetric modeling and using the *Box* statement along with the *MTranslate* statement. In each example the dimensions of the room are: (W, L, H) = (4, 6, 2.7).

Below the box shaped room is modeled using plain decimal numbers:

```

Parametric sample BoxFromPureNumbers.par
###
Pt      1      0      2      0
Pt      2      0     -2      0
Pt      3      6     -2      0
Pt      4      6      2      0
:ceiling points
Pt     11      0      2      2.7
Pt     12      0     -2      2.7
Pt     13      6     -2      2.7
Pt     14      6      2      2.7
Surf    1      floor
      1      2      3      4

Surf    2      ceiling
      11     12     13     14
Surf    3      end wall
      1      2     12     11

Surf    4      end wall
      1      2     12     11

Surf    5      side wall
      1      4     14     11

Surf    6      side wall
      2      3     13     12
###

```

Below the box shaped room is modeled using constants for the definition of W, L and H. Some of the advantages of using parameters in modeling rooms are that it makes changes to a model much easier (allowing reuse) and often it will also improve the clarity of a model data.

```

Parametric sample BoxFromParameters.par
The box measures are:
Width = 4 metres
Length = 6 metres
Height = 2.7 metres
###
const   W      4
const   L      6
const   H      2.7

```

```

Pt      1      0      W/2    0
Pt      2      0      -W/2   0
Pt      3      L      -W/2   0
Pt      4      L      W/2     0

Pt     11      0      W/2    H
Pt     12      0      -W/2   H
Pt     13      L      -W/2   H
Pt     14      L      W/2     H

Surf    1      floor
I>4

Surf    2      ceiling
I1>14

Surf    3      end wall
I      1      2      12      11

Surf    4      end wall
I      1      2      12      11

Surf    5      side wall
I      1      4      14      11

Surf    6      side wall
I      2      3      13      12
###

```

Below the box shaped room is modeled using parameters and symmetric modeling syntax (signs on point and surface numbers). The symmetric modeling syntax means less typing and less typing errors:

```

Parametric sample BoxFromParametersUsingSymmetricModeling.par
###
const W 4
const L 6
const H 2.7

Pt      1      0      W/2    0
Pt      2      L      W/2     0

Pt     11      0      W/2    H
Pt     12      L      W/2     H

Surf    1      floor
I      1      2      -2      -1

Surf    2      ceiling
I      11     12     -12     -11

Surf    3      end wall
I      1      11     -11     -1

Surf    4      end wall
I      2      12     Mirror
Surf    -5     side wall
I      1      2      12      11
###

```

;Mirror works just as well – defines point -12 and -2

Below the box shaped room is modeled using the *Box* statement, which is the easiest way to create this simple geometry. A *MTranslate* statement is used to insert the *Box* at the same position as in the three other examples:

```

Parametric sample BoxStatement.Par
###
const L 6
const W 4
const H 2.7

MTranslate I/2 0 0

```

Modeling a cylinder

This example shows two different ways to create a cylindrical room with a floor and a ceiling. In the first example the room is modeled using the *Cylinder* statement:

```
Parametric Sample CylinderStatement.Par  
###  
const N 16  
const R 15  
const H 10  
  
Cylinder 1000 N R 360 H TB Cylindrical room  
###
```

The *Cylinder* statement is of course the easiest way to model a cylinder, however sometimes more flexibility is needed (e.g. different radius in top and bottom). In the second example the corners in the room are modeled using the *CountPt* statement and the cylindrical surfaces are modeled using the *RevSurf* statement. Notice that the number of points created by the *CountPt* statement is one higher than the number of sections in the *RevSurf* statement. The bottom and top of the room is modeled using the *Surf* statement, notice that points used by these surfaces are referenced using the statement *100>100+Sections-1* rather than writing each of the sequential points, this is not only a faster way to write things, it also allows a rapid change to the number of sections in the cylinder by simply changing the *N* constant.

```
Parametric sample, a cylinder RevSurfCylinder.Par  
###  
const N 16  
const R 15  
const H 10  
  
CountPt 100 N+1 R*CosD((PtCounter)*360/N) R*SinD((PtCounter)*360/N) 0  
CountPt 200 N+1 R*CosD((PtCounter)*360/N) R*SinD((PtCounter)*360/N) H  
  
RevSurf 300 100 200 Sections cylinder walls  
  
Surf 100 Circular floor  
100>100+N-1  
  
Surf 2 Circular ceiling  
200>200+N-1  
###
```

Modeling a box shaped room with columns in two dimensions, using two level *For..End* constructs

When modeling geometries having more than one level of symmetry it is advantageous to use *For..End* constructs. This example shows how to model columns in two dimensions in a room using a two level *For..End* construct.

Each column is created using 8 points and 4 surfaces, thus the numbering used by points and surfaces is incremented by 8 each time a column is created. This is done by incrementing the predefined variable *NumbOffSet* by eight for each column in order to make surface and point numbers unique. The different positions of the points used for each column are obtained, using *MTranslate* and *MReset*.

```
Parametric sample BoxColumnRoom.Par  
###  
const L 10  
const W 4  
const H 3  
const NumColX 4  
const NumColY 3  
const ColumnW 0.3  
  
mTranslate l/2 0 0  
Box 1 l w h t b walls in the room  
:modeling the columns
```

```

for ColYCnt 1 NumColY
MReset
MTranslate L/(NumColX+1) w/2-ColYCnt*W/(NumColY+1) 0
for ColXCnt 1 NumColX
NumbOffSet NumbOffSet+8 ;comment: hint! setting NumbOffSet to Auto would do the same job
Box 1 ColumnW ColumnW h n columns in the room
MTranslate L/(NumColX+1) 0 0
end
end
###

```

Using hybrid statements and coordinate manipulation

The following example demonstrates an example on how to use the hybrid statements *Cylinder2* and *Dome2* as well as the coordinate manipulations, which are essential to the use of the hybrid statements.

This example is a rather complex one, so the main parts of the file is explained below:

- Line 3-7 Defining constants.
- Line 8-9 Inserting the cylindrical wall, which needs a rotation of 90° around the Z-axis.
- Line 11 The foot-points of the cylindrical wall, which is temporarily stored in *PListA* are stored in *PList0* for later use (definition of the floor).
- Line 12-13 Inserting the dome shaped ceiling. The Z-rotation has already been set to 90° when the wall was created.
- Line 14-18 Setting the coordinate manipulation for the ceiling and creating the ceiling.
- Line 19 Resetting the coordinate manipulation to work in absolute coordinates
- Line 20-23 Creating Wall /floor point
- Line 24-25 Defining floor, using the 'cylinder points' stored in *PList0*.
- Line 28-29 Defining side walls using symmetric modeling.
- Line 30-31 Defining back wall, using the 'ceiling cylinder points' which is still stored in *PListB*.

1. *Dome2 and cylindger2 x 2 room.par*
2. ###
3. *const H 5*
4. *Const L 10*
5. *Const W 15*
6. *Const N 12*
7. *Const HCurve 4*

8. *MRotateZ 90*
9. *Cylinder 1000 N W/2 180 H N*
10. *//Storres PListA for later use with floor*
11. *PList0 PListA*

12. *MTranslate 0 0 H*
13. *Dome2 2000 N W HCurve 180 Halfdome*

14. *MReset*
15. *MRotateZ 90*
16. *MRotateY 90*
17. *MTranslate 0 0 H*
18. *Cylinder2 3000 ONVert W HCurve L n Cylindric ceiling*

19. *MReset*
20. *Pt 1 0 W/2 0*
21. *Pt 2 L W/2 0*
22. *Pt 3 0 W/2 H*
23. *Pt 4 L W/2 H*

24. *Surf 1 Floor*
25. *2 PList0 -2*

26. *//done with PList0 its a good habit to Reset it*
27. *ResetPList0*

28. *Surf -2 Side Walls*
29. *1 2 4 3*
30. *Surf 3 BackWall*

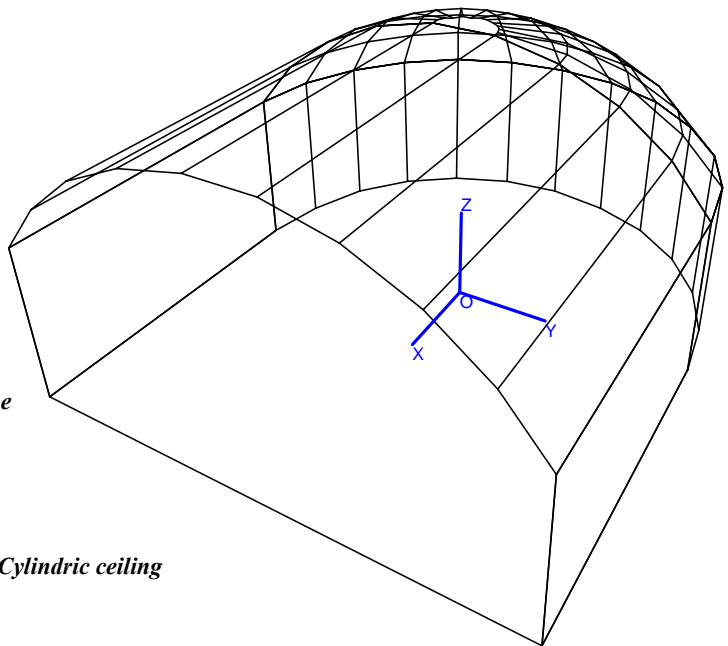

Defining surfaces with concave edges

Most surfaces in the geometries used with ODEON will probably be have convex edges (rectangles, cylindrical surfaces etc.), however in ODEON, it is possible to define surfaces with cavities, even surfaces with holes. Such surfaces are defined just like any other surface, by creating a list of corners where the listing is obtained by travelling around the surface's edge (in either direction). Below are two examples; one with a donut shaped balcony floor and another with a cylindrical window opening in a ceiling.

In the donut example two 'rings of corners' are created using the *CountPt* statement, notice that the point 100 is equal to point 112 and point 200 is equal to point 212. The donut surface is created, simply by connecting the inner and outer ring of points into one surface. It doesn't matter whether one of the rings are created clock or counter-clockwise. The surface is created from the following list of points: 100,101,102,...,110,111,112,200,201,202,...,210,211,212

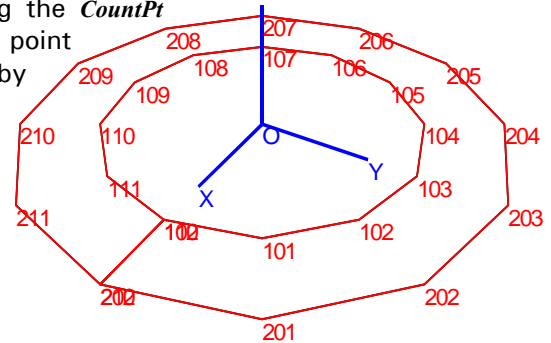

```

DonutSurface.par
###
Const R1 10
Const R2 15
Const N 12
CountPt 100 N+1      R1*cosD(360*PtCounter/N)      R1*sinD(360*PtCounter/N) 0
CountPt 200 N+1      R2*cosD(360*PtCounter/N)      R2*sinD(360*PtCounter/N) 0

Surf 100 Donut surface
100>100+N 200>200+N
###
    
```

The window example shows how a cylindrical window opening is created in ceiling surface. The interesting surface in this example is surface 1, the ceiling surface. The surface is created from the following list of points: 1,100,101,102,103....,111,112,1,2,3,4

```

CeilingWithWindowTube.par
###
Const R1 0.75
Const R2 0.5
Const N 12

Pt 1 1 1 0
Pt 2 1 -1 0
Pt 3 -1 -1 0
Pt 4 -1 1 0

CountPt 100 N+1 R1*cosD(360*PtCounter/N) R1*sinD(360*PtCounter/N) 0
CountPt 200 N+1 R2*cosD(360*PtCounter/N) R2*sinD(360*PtCounter/N) 2

Surf 1 Ceiling
1 100>100+N 1>4

RevSurf 2 100 200 N Window tube

Surf 100 Window /glass
200>200+N-1

###
    
```

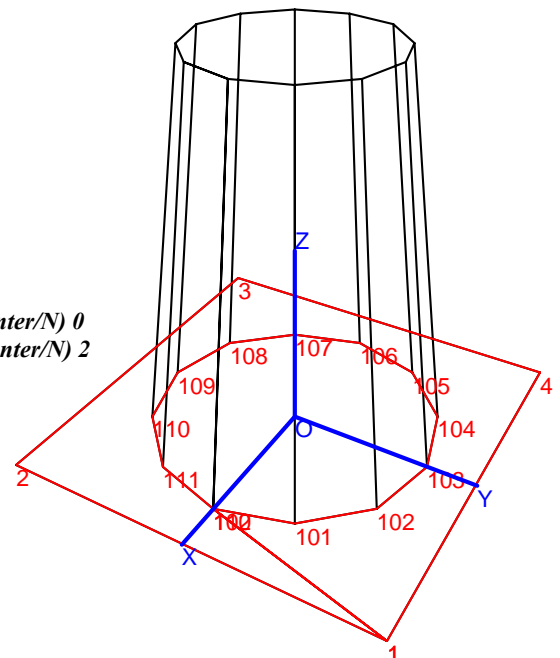

3.3 Odeon Extrusion Modeler

 A small modeling program; the Odeon Extrusion Modeler is included with Odeon. The program is found in the Windows start menu along with the Odeon program. It can also be launched from within the Odeon editor.

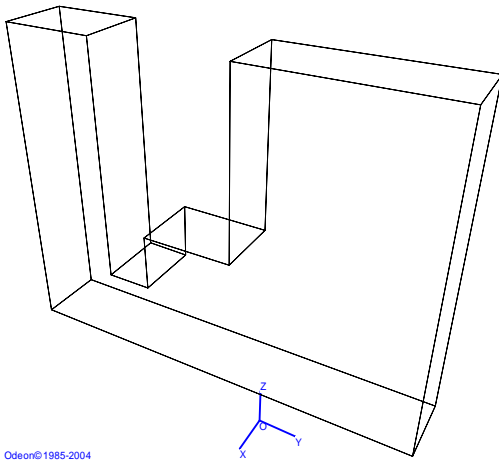

Odeon©1985-2004

In the extrusion modeler it is possible to make one drawing which contains multiple extrusion surfaces, each described by a 2D outline (a simple drawing) and the line properties; drawing depth, extrusion height, bottom flag, top flag and a name. If the extrusion is created in the XY- plane, then one extrusion surface may form walls (floor and ceiling), whereas other extrusion surfaces define tables, chairs or screens.

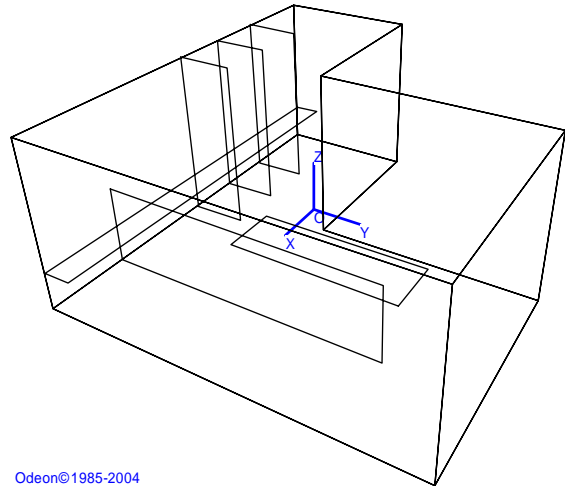

Odeon©1985-2004

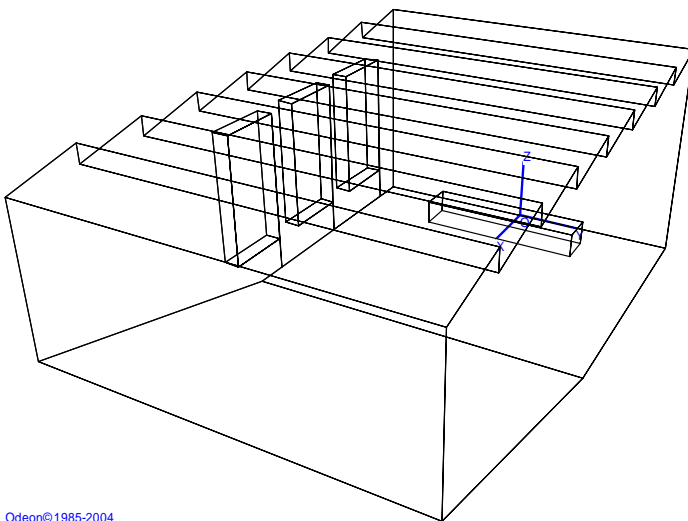

Odeon©1985-2004

For some geometry it may be more appropriate to draw the geometries in one of the other main planes (XZ and YZ planes). As an example the auditorium.par model in the figure has been modeled in the XZ plane, using separate extrusion surfaces for the room, the wall with windows holes, the table and the windows.

The Extrusion Modeler and file formats

The output from the extrusion modeler comes in two formats; the extrusion model can be saved in its own native format in an .oes file. This file can be edited and extended at a later point in the extrusion modeler e.g. if wishing to change width of the auditorium above, to change some of the points in the drawing or to add other features.

The other format is the Odeon .par format which is loaded into Odeon for calculations. The parametric format can not be edited in the extrusion modeler; on the other hand it may be edited to any degree of freedom if needed and it is possible to make use of the benefits of the parametric format described in section 3.2 e.g. when modeling geometric shapes such as cylinders and domes or when it is appropriate to describe parts of a geometry using parameters. The .par file can be edited in the Odeon text editor OdwEdit. The 3DView available in Odeon is a useful tool when investigating or modifying an already existing file; load the .par file into Odeon, study the room in the 3DView – please see the help

text, shortcut F1, available from within this display, then make the changes in the editor which can be opened from within Odeon.

Using the Extrusion modeler

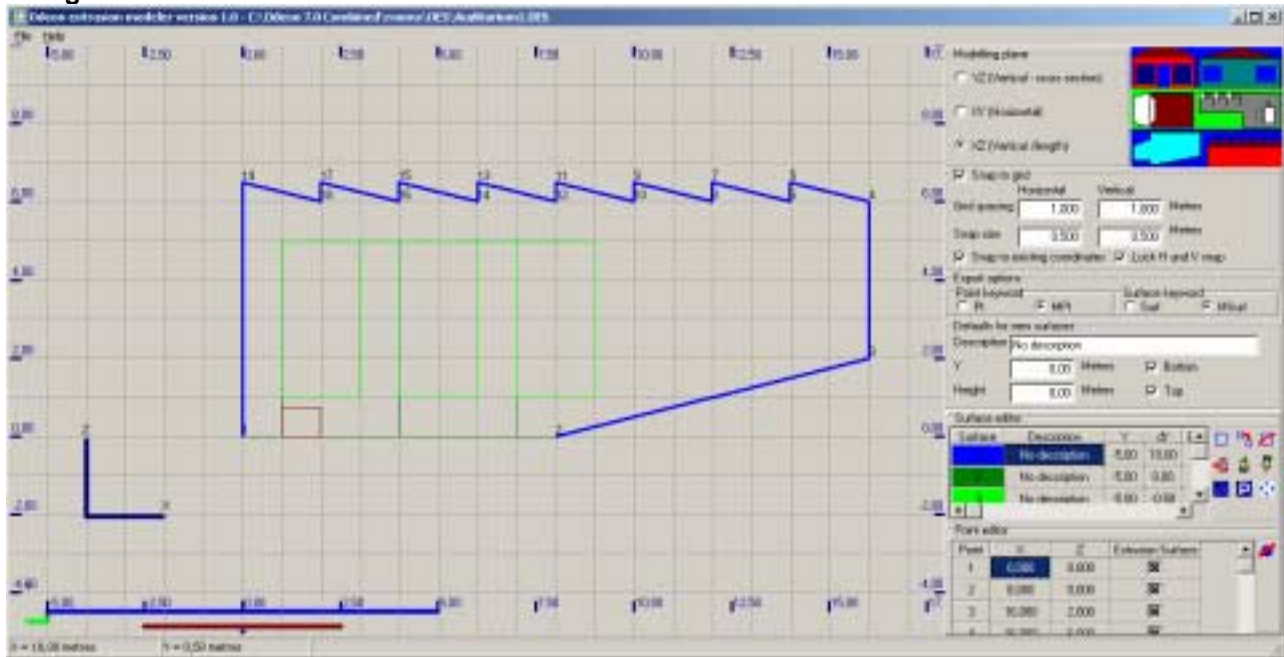

Start the program, a shortcut to the program is found at the Windows Menu Start|Programs|Odeon ...|OdeonExtrusionModeler.

Initial settings

Before starting modeling geometry, select the drawing plane which is best suited for the geometry to be modeled. Also select properties for grid and snap spacing.

Drawing an extrusion surface

Left click the mouse at the positions where the points in the surface are desired – if no points and lines are generated then you need to bring the current surface in edit mode using the Insert (or Esc) shortcut or by double clicking a point in the surface. Once all points in the surface have been defined, finish the current surface by starting a new one, using the Ctrl+A shortcut or pressing the Insert or Esc shortcut. To assign a drawing depth (X,Y or Z) and an extrusion (dX, dY or dZ), select the surface in the Surface editor table where it can also be specified whether the surface should have a bottom and a top and a Description may be entered. The drawing depth and extrusion for each extrusion surface is displayed graphically at the bottom of the application window.

Editing or correcting an extrusion surface

In order to make corrections to an extrusion surface, select it in the Surface editor table and bring it into edit mode using the Insert (or Esc) shortcut. Once in edit mode it is possible to change coordinates of the points, insert or delete points and to move the surface using the mouse operations listed below. It is also possible to enter the precise coordinates of points in the Point editor table which list the point in the selected surface, so it is an option to draw a sketch using the mouse and then fine tune the coordinates afterwards in the Point editor table.

Operation on surface	Mouse operation
Create a new point in selected surface	LeftClick mouse
Select the point in selected surface, which is closest to Mouse pointer	Ctrl+LeftClick mouse
Move closest point in selected surface	Ctrl+Alt+LeftClick mouse
Move selected surface	Shift+LeftClick mouse
Move selected surface when its not in edit mode	LeftClick mouse

Manipulating the viewport

The viewport can be manipulated using the shortcuts listed below. It is possible to make changes to the view while drawing a surface.

View operation	Mouse operation
Scroll drawing area	Right mouse button
Zoom (In/Out)	Alt + Left mouse button

Snap to grid

Snap to grid enables points (new points or points being moved) to be positioned exactly at the intersection of the grid lines. In special cases the point can also be inserted at only one grid line when the other coordinate is that of an existing point, see below.

Snap to existing points

Snap to existing points enables points to be precisely located on either or both reference coordinates of existing points.

The snap point

The snap point is a special case of snap to existing points. In some cases you may want to move a surface to a precise location e.g. (0.33, 0.46) not being a point on the grid nor an existing point of another surface. In that case:

- Create a new surface
- Click the approximate position of the reference point
- Change the coordinates to the exact position, e.g. (0.33, 0.46) in the Point editor.
- Press Insert (or Esc) to finish editing the surface, the point will appear with the mark **+Snap point**
- Select the fix point in the surface to be moved (left mouse button) and move it to the location of the snap point. Do note that Snap to existing coordinates option must be checked.

Once the surface has been moved, the surface containing the snap point may be deleted; this is not a strict requirement as surfaces containing only one point, will not be transferred to the .par format to be used in Odeon.

Relative or absolute extrusions

Use the Ctrl+H shortcut to toggle between relative or absolute extrusions in the Surface editor table. When extrusions are displayed in relative measures an extrusion may be defined as Z=10 and dZ=5, telling that the extrusion starts at a height of 10 and has an extrusion height of 5. If toggling to absolute extrusion then the same extrusion is displayed as Z1=10 and Z2= 15 telling that it starts at Z= 10 and ends at Z= 15.

Modeling an array of surfaces



Each extrusion surface has a set of array properties associated with it, one set for each of the three main orientations in the room. These properties can be found in the Surface editor and define how many times the surface should be repeated in each of the main directions and the distances between the repetitions. This feature is typically used in order to create a number of columns, beams, tables or chairs with a regular spacing. When editing an array surface e.g. modifying a point, all the repetitions of the surface will be changed accordingly. If individual changes are needed, the arrayed surface must be 'exploded'. Once this operation has been carried out the surfaces

in the arrayed surface has been turned into individual surfaces which can be modified surface by surfaces (e.g. delete some of them). It is not possible to perform the reverse of the explode operation so before exploding an arrayed surface, make sure all operations common to the surfaces in the array have been carried out.

Modeling a chair

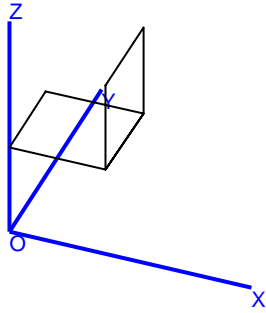

The easiest way to model a chair like the one in the left figure is to simply enter the same data as displayed in the screenshot of the Extrusion Modeler in the right figure; however a few tricks may be found in the description below. If modeling a room in the XY

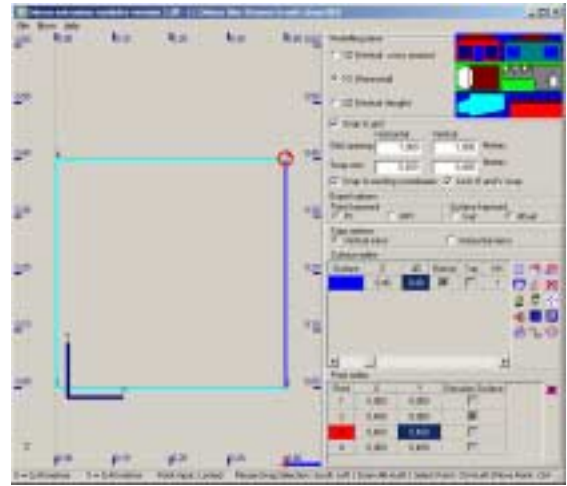

Modeling plane then a chair may in effect be considered an extrusion which excludes the top and three of its sides. In this example we will create a chair with the seat dimensions 0.4 x 0.4 and a back rest with the height of 0.4. Legs and other small details should be omitted.

To make things easier do the modeling around origo, then move the chair to its final location when finished. When modeling around the origo it becomes easier to read the dimensions of the seat of the chair and to use grid and snaps without the need to calculate dimensions of the seat:

- Set the snap size(s) to 0.4 metres.
- Click the 4 points in the seat of the chair (Insert or Esc toggles point input on/off).
- Change the Z coordinate in the chair to 0.4 metres (in the Surface editor) to define seat height.
- Change dZ to 0.4 metres in the (in the Surface editor) in order to define the height of the back of the chair.
- Uncheck Top in the surface editor.
- Uncheck the 3 sides which are not the back of the chair (in the Point editor).
- Finish the surface by pressing the Insert (or Esc) key.
- Finally move the chair to the desired location, using the left mouse button.

Using the circle tool and the mirror



In this example a table plate with circular ends is modeled. a) First a circle is created b) Then half of the circle is deleted c) Finally the surfaces is mirrored in a horizontal mirror at $y = -1$.

Creating a circular surface

To create a circular surface, first draw a line (a surface with two points) in order to specify centre and radius or the circle, then use the Ctrl+O shortcut to activate the circle tool and accept to create a circle from 12 points. If the circle tool is clicked when the selected surface contains less than two or more than three points then a help text is displayed, this text will also explain about ellipses.

Make a circle half a circle

Delete the 5 upper points in the circle in order to reduce the circle to half a circle. At this point you should have created the half circle in middle of figure above.

Mirroring the surface

In order to create the complete table, the mirror functionality can be used; select the horizontal mirror and specify the coordinate of the mirror line (in the figures the coordinate was -1.00). Select the first

of the two points to be connected across the mirror line and finally use the Mirror shortcut Ctrl+M to create the full table. The position of the mirror is easily changed if holding down the Shift key while pressing Right mouse and moving it – if performing a very significant move in the horizontal or vertical direction this will toggle between a horizontal and a vertical mirror line.

Mirror manipulation	Mouse operation
Move mirror line /toggle between vertical and horizontal mirror line	Shift+Right mouse button

Rotating a surface

To rotate a surface, select the point in the surface around which the surface should be rotated, then activate the Rotate dialog using the Ctrl+R shortcut and enter the number of degrees to rotate the surface (positive rotation angles are always counter clockwise - CCW). A surface can not be rotated around a point which is not included in the surface however this trick will do it, insert the point of rotation into the surface:

- Select the surface.
- Bring it into editing state (Esc or Insert shortcut).
- Add the rotation point (it is not important where it is inserted in the sequence of points).
- Rotate the surface.
- Delete the rotation point from the surface (Del shortcut)

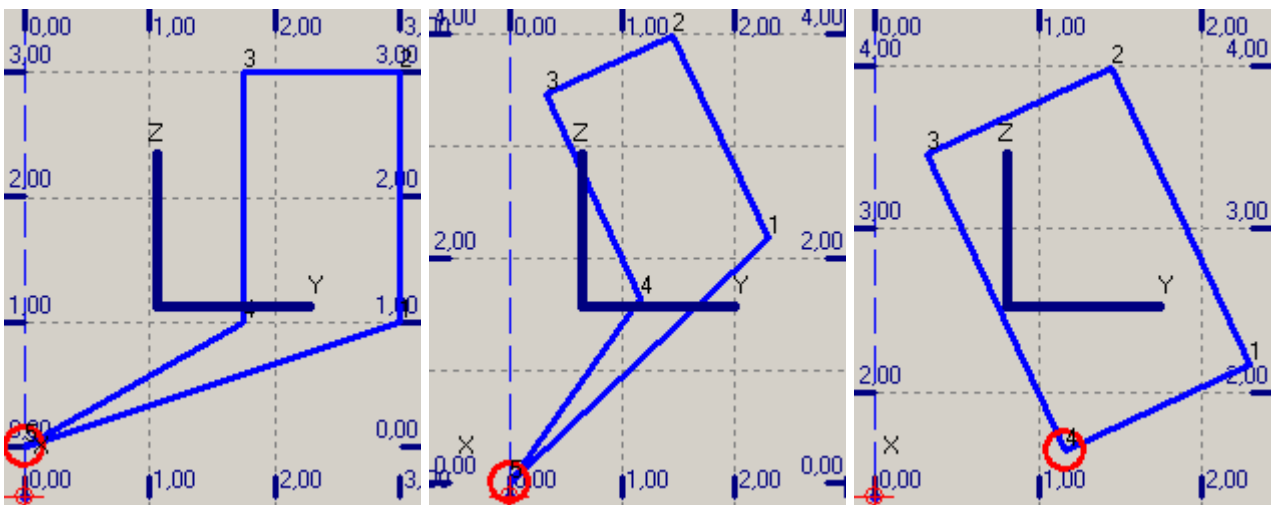

To rotate a surface around a point which is not included in the surface, a) Insert a rotation point in the surface, b) Use the Rotate surface shortcut Ctrl+R to activate the rotation dialog and specify the rotation angle – in this case 25 degrees, finally delete the rotation point from the surface.

Examples

A few examples on extrusion models are installed with Odeon – the examples are located in the \odeon.\rooms\oes Directory. The best way to learn about benefits as well as limitations of the extrusion modeler may be to load the examples, investigate the surfaces (e.g. scrolling the point and surface tables) and to load the models into Odeon in order to investigate the models when they become extruded.

Special extrusions

There are a few extrusion surfaces which are treated differently by the extrusion modeler:

1. A surface with an extrusion height of zero will produce one and only one 'horizontal' surface no matter if a bottom or top surface is selected.
2. An extrusion surface which only contains two points will only produce one 'vertical' surface, neither bottom or top surface is produced, only a single extruded surface (if the extrusion height of this surface is zero then no surface is produced - an exception to the exception).

3.4 Importing DXF files

The support for the DXF file format (Drawing eXchange Format), allows import of CAD models exported from modeling programs such as:

CAD package	Web addresses	Demo available for download
IntelliCAD	http://www.autodsys.com or www.intelliCAD.com	X
Google SketchUp	http://sketchup.google.com/	X
AutoCAD	www.autodesk.com	
3DStudioMax	http://www.discreet.com/	X
Rhinoceros	www.rhino3d.com	X

There may also be other programs around, capable of creating geometry data which can be used with Odeon. Odeon supports a number of CAD entities which can be exported from these programs and imported directly by Odeon without any extra effort. Depending on the modeling program used and indeed how it was used, different approaches may need to be taken in order to ensure that all or most of the drawing data are exported to the DXF file in a form which can be understood by Odeon. If Odeon encounter entities in the import process, which Odeon recognizes, but doesn't support, then Odeon will notify about the problem.

The modeling programs should be 3D modeling programs. Programs such as AutoCAD LT only have limited support for 3D modeling and are not recommend. Programs such as AutoCAD 2002, IntelliCAD 6 Profesional Pro and 3DStudiomax are true 3D modeling programs and have been reported to be suited for the purpose. Other programs may work as well, but in any case you may have to experiment in order to find the optimum way to export and import the geometries from the programs.

About CAD drawings

Room models to be used by ODEON must be surface models defined from plane surfaces, no matter if the models are created in a CAD program or if they are modeled in the ODEON environment (e.g. using the ODEON .par format). Once a model has been successfully imported by ODEON, it is important to perform a thorough check – geometries which look fine in the 'drawing program' may still contain serious errors, such as repeated, misplaced or missing surfaces.

3.4.1 CAD entities supported by ODEON

Irrelevant drawing entities which are not supported

Many CAD drawings are in fact 2D 'paper drawings' rather than 3D models. Such drawings do not contain sufficient information to create a 3D surface model and are ignored in the import process. Examples of drawing entities which are ignored are circles, dimensioning lines, texts etc. 2D drawing data may coexist peacefully in a drawing containing useful 3D data – the 2D data are as stated simply ignored.

It is possible to convert a few 2D entities into model data useful for Odeon, provided that it is done from within the CAD program, see the *2½D entities* paragraph.

BLOCK's are not supported

ODEON can not import entities which were inserted into a drawing as BLOCK's. Any BLOCK in a drawing which contains relevant 3D surface data must be exploded using the EXPLODE command before exported to the DXF file. Odeon will notify the user if the DXF file imported did indeed contain BLOCK's.

3D surface entities supported by ODEON

- 3DFACE
- Poly meshes: MESH, WEDGE, PYRAMID, BOX, CONE, CYLINDER, SPHERE, DISH, DOME, TORUS, EDGESURF, RULESURF and any other entities based on poly-meshes.
- Poly faces, the PFACE entity and any entity based on poly-faces.

2½D entities supported by ODEON: LINE, POLYLINE, CIRCLE

Odeon can import LINE, POLYLINE, ARC and CIRCLE entities, so called 2½D entities, when the elevation height is set to a value different from zero using the ELEV command in the CAD program. Using the ELEV command (at least this is true in IntelliCAD and AutoCAD) makes it possible to convert parts of a

flat line drawing into a 3D drawing – typically a 2D floor plan can be converted into a set of (vertical) walls. Use the CHANGE command in order to change elevation and height of these entities from within the CAD program.

3DPOLY

As an option it is possible to import 3DPOLY (3D polylines) as if they were surfaces when these lines are closed polygons. When Odeon exports surfaces containing more than 4 four points these surfaces are exported as 3DPOLY-lines. 3DPOLY-lines will not respond to the HIDE or the RENDER commands when imported into e.g. AutoCAD, however it is possible to convert POLYLINE's into REGION entities which are visualized correctly as surfaces in some CAD programs (if the 3DPoly's are not plane, this may not work). In some cases it may be desirable to switch this import option off when importing to Odeon as the DXF file may contain such entities which the modeler did not intended to be included in the 3D surface model to be imported – the entities may have been modeled for other reasons e.g. as assisting lines in the modeling phase.

POLYLINE (when the POLYLINE is closed and the elevation height is set to zero)

This entity is not really a true surface; however in some cases it may be use by some CAD programs, including AutoCAD in order to bypass the limitation of maximum four points in a surface. If a geometry which was exported from ODEON to the CAD program is to be imported into ODEON again this option should be on in order to import all 3D data. In some cases it may be desirable to switch this option off as the DXF file may contain such entities which the modeler did not intended to be included in the 3D surface model to be imported – the entities may have been modeled for other reasons e.g. as assisting lines in the modeling phase.

3DSOLID, REGION, BODY – recognized but not supported

These entities are ACIS solid modeling entities, which are not directly supported by Odeon. However solid modeling is probably the most powerful way of creating 3D surface models allowing the use of commands such as UNION, SUBTRACT, INTERSECT, SLICE, INTERFERE etc. and with a few steps it may be possible to convert these entities into something which is understood by Odeon.

In IntelliCAD Professional Pro 6 the 3DCONVERT command will convert above mentioned entities into entities recognized by ODEON (Poly-faces). It is recommended to perform this operation on a copy of the CAD file rather on your original.

In 3DStudioMax select all the entities in the drawing using the Ctrl+A shortcut, then right-click the mouse on the drawing and select the Convert to|Polyfaces (other options may also work). It is recommended to perform this operation on a copy of the CAD file rather on your original.

In AutoCAD 2000 the conversion process involves exporting to a 3D Studio Max file and re-importing the exported file:

- Export the geometry into a 3D Studio file using the 3DSOUT command (this does not change your current CAD drawing)
- Import the 3DStudio file just created back into a new (clean) drawing in AutoCAD, using the 3DSIN command. In this new drawing the above entities has been converted to Polyface entities which are supported directly by ODEON. At the same time all entities contained in BLOCK's have been exploded, making them appear explicit, thus directly compatible with Odeon.

If Odeon reports of any of the unsupported entities when the .dxf file has been imported, this is because some 3D data is available in the DXF file in a format which can not be converted by ODEON. Consider following the steps above in order to create a .dxf file which can be converted by ODEON. Do note that ACIS solid modeling extensions may not be available in all editions of the various modeling programs.

Using LAYER's in the CAD drawing

Surfaces will when imported to ODEON carry the name of the layer on which they were drawn. Use the layer name to give the different parts of the geometry different names, e.g. draw the stage floor surfaces on a layer named *Stage floor*, the sidewalls on a layer named *Sidewalls* etc.

If you are modeling subdivided surfaces such as *Upper wall* and *Lower wall* because you wish to be able to assign different materials to these parts of a surface, it is advisable to model these parts on different layers in order to avoid that ODEON glues these surfaces together (described below). If a

drawing is subdivided into layers, this also makes it easier to assign materials to the surfaces in the Material List in ODEON because materials can be assigned to all surfaces on a layer in one operation.

Exporting a geometry from Odeon to IntelliCAD or AutoCAD

When Odeon exports surfaces containing more than 4 points each, these surfaces are exported using the 3DPOLY entity whereas all other entities are exported using the 3DFACE entity. The 3DPOLY will appear as 3DPOLY lines in the CAD program and does not respond to the HIDE and RENDER commands like entities such as 3DFACE do. However using the REGION command it is possible to convert 3DPOLY's into REGION's which do respond to the HIDE and RENDER commands.

Before exporting from the CAD program

Remember that BLOCK's are not supported by ODEON, BLOCK's containing relevant 3D info must be exploded using the EXPLODE command in the CAD program (in AutoCAD this may also be done by exporting the file to the 3ds (3D Studio Max) format and importing it again as described in the section on 3DSOLIDS).

3DSOLID, REGION and BODY entities are not supported by ODEON, try using one of the approached listed above in order to make the geometry compatible.

A final remark is that it is always a recommended practice to make backup copies of your CAD files before making any conversions.

3.4.2 Performing the import in Odeon

To import a DXF file:

- Select Files|Import from file (dxf, 3ds, cad) or simply drop the file on the Canvas of Odeon.
- Specify the input file e.g. MyCADRoom.dxf
- Specify the destination file e.g. MyCADRoom.Par

Once the file names have been specified, the Import DXF file dialog appears allowing miscellaneous import options to be specified. By default most of the parameters may be left untouched – however it is important that the correct drawing *unit* is specified. If the geometry does not appear as expected, you may try other input parameters.

Unit in input file

Unfortunately .dxf files are unit-less. It is important that the correct unit in which the geometry was modeled is selected in the import dialog. If the correct unit is not specified the import process may fail because the geometry seems to be only a few millimetres large or several kilometres in size.

Geometric rules, glue surfaces

Surfaces imported in the DXF format are, put simple, by nature surfaces build from three or four sets of coordinates. When the glue option is turned on, ODEON will try to glue (or stitch if you wish) these surfaces in order to form fewer surfaces with larger areas. Do note that some surfaces (based on poly-faces) may not import correctly *unless* the glue option is turned on.

ODEON will not combine surfaces with each other when they are situated on different layers in the CAD drawing, thus if you wish that certain surfaces are not glued together, e.g. if upper and lower part of a wall should be assigned different materials, either draw the surfaces on different layers in the CAD program (preferable) or turn off the glue surface's option (may lead an excessive number of surfaces and may not work with poly-faces).

Max. point margin

If points in the DXF file are within this margin, the points will be considered equal. Allowing a certain amount of point margin will allow the Glue function to perform better if the coordinates in the model are not exact. However if you have modeled both sides of a surface (e.g. outside and inside surface of a balcony front edge) the Max point margin should be smaller than the distance between these surfaces, otherwise the points on either side of the surface will be considered the same, with disastrous results.

Max. warp

ODEON will split four point surfaces into 2 three-point surfaces, if the surface's warp exceeds this value. The glue option on the other hand will try to glue surfaces as long as this does not lead to a surface exceeding then max. warp.

3.4.3 Editing the imported geometry

It may be necessary or at least desirable to make changes to geometry once it has been imported. The 3DView display, which displays the geometry once it has been imported, is a useful tool for this purpose, please see the context sensitive help available in this display from within Odeon for further details (shortcut F1).

Example: Importing the supplied ElmiaDXFSample.dxf and changing its Origo

Try importing this .dxf file which is located in the \room\ directory. To make the operation of Odeon as smooth as possible it is desirable to move the *Origo* of this geometry. Once the geometry has been imported this change may be made as follows:

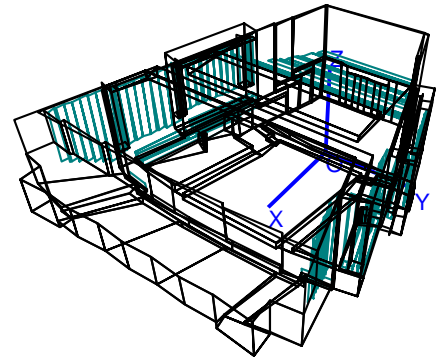

Investigate the coordinates of the front edge of the stage:

1. Turn on the modeling options in the 3DView (shortcut M) on and move the mouse in order to investigate the corners coordinates.
2. If pressing the Ctrl-key while Left-clicking the mouse then the data for the closest corner is copied to the clipboard – the data /text can be pasted into the Odeon's editor using the Ctrl + V shortcut.

Pasted corner data from the 3DView			
Pt	?48?	10.500-5.90000	24.00000 //for a left point on the stage
Pt	?47?	10.5005.90000	24.00000 //for a right point on the stage

We may want to locate *Origo* at the front of the stage. This can be done using the *Mtranslate* statement in the geometry file in order to move the mid-point (average of the two points above) of the stage to (0,0,0) – open the .par file, clicking the Odeon editor icon, then just after the ### sign type:

```
MTranslate    -(10.5+10.5)/2    -(-5.9+5.9)/2    -(24+24)/2
```

At the end of the file just before the ### sign, type *MReset* in order to make the coordinate system neutral – this is desirable when adding new surfaces to the geometry.

Click the Odeon icon inside the editor in order to save the modified geometry and reload it into Odeon.

Other coordinate manipulations to the geometry may be desirable; in particular the *CoordSys* statement described in section 3.2.1 may be useful.

Trouble shooting

Problem with zoom or translation in the 3DView: Model appears in a strange position on the screen and zoom /translation does not work as expected. This problem is probably caused by some small (invisible and irrelevant) surface(s) located at odd position(s) in the imported model.

Solution 1: Try importing the geometry once again with some of the entities unchecked (turned off), it may be that some of the entities, such as 3DPOLY or the like were not intended to be surfaces.

Solution 2: Removing the unwanted surface:

- In the 3DView turn on the 'Modeling options' (M-shortcut), look out for odd positioned points.
- Move the mouse cursor to the position of the odd point - read one of these point numbers
- Click the OdwEditor icon to open the .par file, remove the point and try to reload the room by clicking the Odeon icon in the Editor. Now Odeon will hopefully report an error stating a surface is referencing the point (which no longer exists)
- Remove that surface along with ALL the points it is referencing (out-comment them)
- Reload the room.

Problem with display of coordinate system: The blue coordinate system looks odd or behaves strangely.

Solution: If the *Origo* is situated in a point far away from the geometry, the coordinate system may not display properly when projection is turned on – in that case turn off the projection using the P-shortcut. In order to fully solve the problem the position of the origo should be altered as described in the example above.

The geometry displayed in the 3DView appear to be too small or large after re-import

If the geometry was initially imported using an incorrect unit then Odeon has defined its default view list in the 3DView in order to display that initial version of the geometry correctly. To reset the view list, use the Ctrl+DEL Shortcut from within the 3DView.

3.5 Model check in ODEON

The geometry file is the first file used by ODEON when assigning a file from Files|Open Room model. When assigning a new or modified room its validity is checked.

The check performed by ODEON involves checking whether data is consistent and in the correct format, but not whether a meaningful geometry is being defined. If the geometry passes, then you may start checking if the geometry is meaningful and without errors. This may involve:

- Viewing the room in a 3DView
- Viewing the room in the 3DOpenGL display
- Analysing the geometry for unacceptable surface warps in the 3DGeometry Debugger.
- Analysing the geometry for unacceptable surface overlap in the 3DGeometry Debugger.
- Checking for missing surfaces in the room (forming holes in the geometry). The Unique edge's function available from the 3DView may help you (shortcut E).
- Testing water tightness of the room, tracing rays in the 3D Investigate Rays or 3D Billiard window.

3.5.1 Viewing the room in a 3DView

The 3DView displaying your room once loaded into ODEON has a large number of facilities which can be useful when creating and verifying geometries for Odeon.

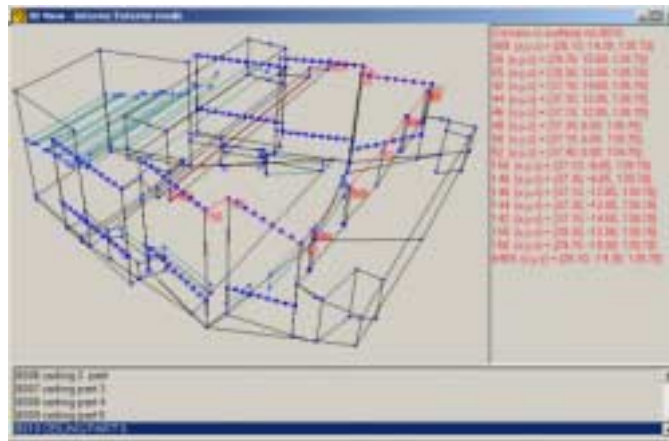
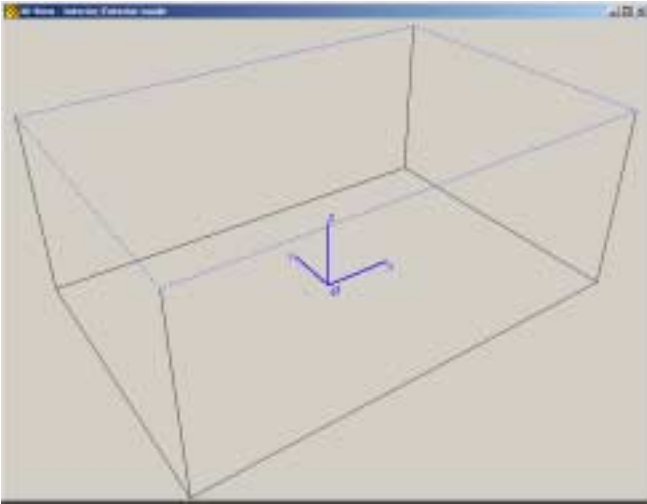

Figure 1 Viewing corners and coordinates in a selected surface using the N shortcut and highlighting corner and displaying the coordinates of the corner closest to the mouse pointer using the M- shortcut.

The perspective option (shortcut P) allows you to turn off the perspective of the room, to get an isometric display of the room. This may prove valuable when investigating warped surfaces.

The Unique edge's option in the 3DView display shows edges, which only occur on one surface. Such an edge is "free"; it might be the edge of a free-hanging reflector, but it could be the result of an error whereby two surfaces, which should join along an edge, do not.



Example:
Modeling a box shaped room consisting of 6 surfaces, but forgetting to define the 6th surface in the geometry file. This room will have a hole where the 6th surface is missing. The unique edge's option will show where the missing surface should have been.

3.6 Combining geometries

It is possible to combine geometries imported from an external CAD program with geometry modeled in the Extrusion modeler or modeled in the parametric modeling format of Odeon. A geometry imported from a CAD program or generated in the Extrusion modeler is always in the .par format and as such they may be combined in the Odeon Editor. When combining different geometries from different sources, some facilities in the parametric modeling format may be quite useful: NumbOffset, CoordSys, Unit, MTranslate, MRoteteX, MRoteteY, MRoteteZ, MScale, MReset and MPop. Below is an example/outline which illustrates how number of geometries can be merged together in one parametric file;

```
###
CoordSys X Y Z
.....1. model data.....
.....1. model data.....

NumbOffset 1000 ;avoid reusing point and surface numbers which has already been used
CoordSys Y X Z ;swap coordinate axes if needed
MTranslate 0 15 20 ;Translate /move geometries as needed
.....2. model data.....
.....2. model data.....

NumbOffSet 2000
MReset ;restoring default origo
CoordSys X Y Z; restoring default coordinate system

.....More model data ???
###
```



Using the 3DOpenGL display for model verification

This display is very useful for detecting holes in the geometries. Especially if stepping outside the model (Arrow-back shortcut) and rotating the model using the Ctrl+Arrow shortcut. See the corresponding 3DOpenGL dropdown menu for more shortcuts. When materials have not been assigned to all surfaces in the room, surfaces will appear in random colours making holes easier to spot. If materials have been assigned, the colours will by default reflect the acoustic properties of the surfaces, however it is possible to turn on the random colouring at will, using the R-shortcut.

Do note! That 3DOpenGL may occasionally fail to display complicated surfaces including numerous holes correctly (typically surfaces created by CAD software using solid modeling techniques and substractions) although the surfaces are perfectly legal with respect to ODEON. In these rare cases you may assure yourself that the model is in fact correct by putting point sources at various test positions and conduct tests using the 3D Investigate Rays and 3D Billiard utilities.

3.6.1 3DGeometry debugger

Overlapping and warped surfaces should be avoided in the room model specified in the geometry file, but a certain amount of overlap and warp (by default 50 mm) is allowed without generating a warning. By overlapping surfaces is meant surfaces, which define a part of the same plane in space. In the

simple case this can be because the surfaces are simply duplicates, another case could be a door, which has been defined in the same plane as the wall in which it is mounted. Overlapping surfaces should be avoided because it will not be clear which absorption coefficient should be applied at a reflection in case of overlapping surfaces.

Warps can lead to "holes" in rooms at edges of joining surfaces, with erroneous results as a consequence and the surfaces will not be well defined.

Using the 3DGeometry debugger in ODEON, ODEON will generate a list of warnings and a corresponding illustration in a 3D display, whenever an overlap or a warp exceeds the value specified in the Room setup|Model|Air conditions dialog.

Overlapping surfaces is a tricky problem because it is usually invisible on 3D projections of the geometries, however such errors in the model may lead to unpredictable results, so always check models of some complexity for overlapping surfaces.

3.6.2 Testing Water tightness using 3D Investigate Rays

Testing a new model for "water tightness" (i.e. whether it is completely closed) may be done using a 3D Investigate Rays window.

The room model may not be watertight if:

- Surfaces are missing from the model.
- Surfaces are unacceptable warped.
- Boundary surfaces have been assigned transparency coefficients greater than zero.
- Boundary surfaces have been assigned Material 0 transparent.
- Sources are located outside the room.

Before investigating ray tracing, you will have to:

- Make the boundary surfaces of the room "solid" by assigning materials to them. For the moment it does not matter what the materials are, as long as they are not transparent (Material 0) or fully absorptive (Material 1). Go into the Materials List and assign, e.g. 20% absorption to all surfaces (use Ctrl+Ins to do this in one keystroke).
- Place a source somewhere inside the room. Sources are defined from the Source-receiver List. At first it may be a good idea to define a point source somewhere in the middle of the room.

Open a 3D Investigate Rays display and run it with, e.g. 1000 rays, with a Max reflection order of zero. This tests whether any holes can be seen from the source position, and should reveal any gross problems. The tracks of lost rays will show outside the room boundaries, and indicate whereabouts in the room, problems occur.

If rays are being lost, and you have an idea of which part(s) of the room is /are "leaky", a number of things may be done:

- Reduce the value of Max. accept. warp in the Room setup at the Model|Air conditions page. Then run the 3DGeometry Debugger. Warnings will appear if surfaces have a warp or an overlap above the acceptable range. This may reveal slight warps of surfaces in the leaky region of the room which then have to be reduced as far as possible by revisions to the geometry file.
- Use the 3DView or 3DOpenGL for inspection of the model to study the region(s) under suspicion. It may turn out that a surface is missing or does not join to its neighbours in the expected manner. It may help to zoom regions in question with the Highlight surfaces, Show corner numbers and coords and Modeling options switched on.

This chapter covers material properties and the facilities available from within the Materials List.

4.1 Special Materials

Material 0 (transparent)

Assigning Material 0 to a surface corresponds to removing the effect of the surface completely from all calculations. Hence surfaces with this material assigned:

- Offer no hindrance to rays, either in energy or direction
- Are excluded from the calculated active surface area of the room, and therefore do not affect the estimate of the room's volume produced by Global Estimate or Quick Estimate Reverberation

This facility can be used to temporarily "remove" surfaces such as doors or reflectors from the room or to define a phantom surface over which an energy map (a grid) is to be plotted.

Material 1 (totally absorbent)

The totally absorbent material (Material 1) may be used for modeling outdoor situations, e.g. an open roof. This is the only material, which will stop the rays during ray tracing and no reflections are generated from surfaces assigned this material.

The material list consists of a window containing two lists, the surface list and the material library. When selecting a surface in the surface list, the surface is automatically highlighted in the corresponding 3D Materials window.

The Material list window consists of two parts:

- Surface List (left part of the window)
- Material List (right part of the window)

Some of the functions available, at the local toolbar as well as from the toolbar dropdown menu:

- **Assign Material**, assigns the material selected in the material list to the surface(s) selected in the surface list.
- **Assign Material for all surfaces**, assigns the material selected in the material list to all the surfaces in the room.
- **Global Replacement** replaces all appearances of the material assigned to the selected surface in the surface list, with the material selected in the material list. This is useful if you wish to replace all appearances of a material with another, e.g. using two layers of plasterboard instead on one.
- **Assigning Scattering coefficient** is done a little different. You simply select the field at the surface and enter the scattering coefficient using the keyboard.
- **Assigning Transparency coefficients**, select field at the surface and enter the transparency coefficient directly using the keyboard.
- **Assigning wall Type** allowing calculation of Transmission through walls or fine tuning scattering /diffraction algorithms.
- **Repeat Scattering coefficient** assigns the scattering coefficient last entered in the surface list to the current selected surface.
- **Repeat Scattering coefficient for all surfaces**, assigns the scattering coefficient assigned to the surface selected in the surface list to all the surfaces.
- **Quick Estimate** for fast evaluation of reverberation times and listing of summarized absorption areas, while assigning materials etc.
- **Edit /Add a material** allow to create new materials or to edit existing ones. The material editor available assists in mixing different materials into one.

Surface List (Material List window)

The surface list, lists the material specifications assigned to the surfaces, starting from the left to the right:

Surface number

The unique number assigned to the surface in the geometry file.

Material number

The number of the material assigned to the surface (from the material library). This number and material correspond to the number listed in the material display, except when:

- The material has been edited in the material library after the material was assigned to the surface (e.g. its absorption coefficients have been changed).
- The materials were assigned on another computer where another material library was available, with different definitions of the material having this number.

Note! Once a surface has been assigned a material, this material sticks to the surface, even though the material has been changed in the material library (Material.Li8), thus calculated results stays in consistency with the materials assigned to the room. To make such a new material take effect in the room please reassign the material, e.g. using the Global Replacement option. Another option is to change the absorption coefficients of room material using the edit fields below the surface list in the left side of the materials list – doing so will change the absorption of all surfaces which has been assigned that material –the material will not change in the material library in the right side of the Materials List.

Scattering coefficient (or diffusion coefficient)

A scattering coefficient is assigned to each surface. This scattering coefficient accounts for the roughness of the material at the mid-frequencies around 700 Hz and it is expanded during calculations in order to take into account the frequency dependent behaviour of scattering, using typically frequency functions for scattering coefficients. This coefficient is taken into account during the ray tracing if Room setup|Calculation parameters|Scattering method is set to Lambert. The scattering coefficient can be assigned values between 0 and 1:

Material	Scattering coefficient at mid-frequency
Audience area	0.6–0.7
Rough building structures, 0.3–0.5 m deep	0.4–0.5
Bookshelf, with some books	0.3
Brickwork with open joints	0.1–0.2
Brickwork, filled joints but not plastered	0.05–0.1
Smooth surfaces, general	0.02–0.05
Smooth painted concrete	0.005–0.02

With the scattering coefficients above, it is assumed that Diffraction surfaces (and Oblique Lambert) has been enabled in the Room Setup. If this is not the case then a minimum scattering coefficient of 0.1 is suggested (0.3 may be more appropriate for disproportionate rooms such as class rooms). If some details are not modeled in a room then the scattering coefficient may also need to be increased – a coffered ceiling where the coffered cells have not been modeled may typically have a value of 0.3 to 0.4 (for the mid frequencies around 700 Hz).

Transparency coefficient - semi transparent surfaces

A transparency coefficient is assigned to each surface; this is a way to make the surface semi transparent. This feature may be used for modeling many small surfaces in real rooms. E.g. a reflector panel built from many small surfaces with space in-between can be modeled as one large surface having a transparency coefficient of, e.g. 0.5. The transparency coefficient can be assigned values between 0 and 1:

- 0.0 is assigned to all solid walls. This value should always be assigned to the boundary walls of the room; otherwise rays will escape from the model.
- Very small transparency coefficients should be avoided unless the number of rays is increased substantially. Instead consider modeling the surface as solid. Using a transparency coefficient greater than zero will cause the Image source method to be discarded for rays hitting such surfaces (only relevant for point sources). Another problem is that only very few rays will be transmitted, making the results on the other side of the surface statistically unreliable.

- Very large transparency coefficients, e.g. 0.95 should also be avoided. Instead consider removing the surface from the model. An easy way to do this is to assign Material 0 (transparent) to the surface. Using a transparency coefficient greater than zero will cause the Image Source Method to be discarded for rays hitting such surfaces (only relevant for point sources).

The Transparency value should not be used for modeling sound transmission through walls - instead use the wall type for this purpose - see below.

Type

The wall Type can be set to Normal, Exterior, Fractional, Transmission. The type Normal, Exterior and Fractional relates to the way *Reflection Based Scattering* is calculated for sound reflecting from the surfaces, Transmission is for walls which transmit sound to another room:

- Normal is the default value which results in default handling of scattering and diffraction taking the *Reflection Based Scattering method* into account if it has been enabled in the Room setup.
- Exterior forces a surface to be handled as an exterior surface even if it was not detected as such by Odeon - the result is that less diffraction is applied at the lowest frequencies where offset in the wall is not sufficient to result in low frequency diffraction.
- Fractional should be used for surfaces which are fractions of a bigger whole e.g. surfaces being part of a curved wall or a dome should not cause diffraction due to their individual area; that is, the individual surfaces do not provide any significant edge diffraction. When setting the type to fractional, the surface area used for calculating the *Reflection Based Scattering Coefficient* is determined from the box subscribing the room - if the construction part which the fractional surface is part of, is considerable smaller than the 'room box' the scattering might be underestimated and a higher scattering coefficient should be assigned to the surface.
- Transmission is for walls which transmit sound to another room. When this wall type has been selected it is possible to edit the transmission data to specify the reduction index (transmission loss) and to link the wall with another surface in case the wall is composed of two parallel surfaces with a distance between them and possibly with different surface materials on either side. When the Transmission type is assigned to a surface, 50% of the rays hitting the surface will be reflected and 50% will be transmitted - the energy calculations are accomplished by multiplying each ray (or particle) with the appropriate frequency dependent energy parameters. Transmission is covered in appendix D.

Surface name

Lists the name given to the surface in the surface file (if given any name)

Area

Lists the calculated area for each surface.

4.2 Editing and extending the Material Library

The materials displayed in the left side of the Materials List window resides in an ASCII file called Material.Li8. This library, provided with ODEON, may be altered and extended at will by the user, using the material editor available from the Material list. If you should wish to add several materials e.g. by copying them from some other file, this is possible by editing the file using the OdwEdit editor which is also available from within the Materials list, and following the ODEON material format.

Special Materials

There are three special materials in the library

- Material 0, transparent
- Material 1, totally absorbent
- Material 2, totally reflective

Although the material library Material.Li8 may be edited, materials 0, 1 and 2 must remain as originally defined.

Data format for materials in Material.Li8

The data format for a material in Material.Li8 is very simple; each material is described by two lines:

```

ID_Number   Descriptive text up to rest of line
a63   a125   a250   a500   a1k   a2k   a4k   a8K

```

ID_Number must be a unique number between 0 and 2.147.483.647.

Absorption coefficients on second line must be floating point within the range 0 - 1 (the line containing 8 floating point values).

5 Auralization

(Combined and Auditorium editions only)

Although much effort has been made to make it as easy as possible to use the auralization capabilities available in ODEON, it is felt that a separate chapter is needed, as this is where all the threads from room acoustics modeling, signal processing, wave signal files, transducers, psycho acoustics, recording techniques etc. meet.

In the description of auralization techniques special words are frequently used, please refer to appendix C; Vocabulary for a short description. In this chapter it is assumed that you have tried the short-guided tour in chapter 2.1.

The basis for auralization in ODEON is either Binaural Room Impulse Responses (BRIR's) or surround sound impulse responses (BFormat is also available for the advanced user), which can be calculated as part of the Single Point Response, in the Job List - if the Auralization Setup|Create binaural filters Or Auralization Setup|Create 2D Surround Impulse Response option is turned on. In this section, only the binaural simulation is covered, but most of the points also go for surround Auralization.

In short terms the BRIR is a two channel filter, through which a mono signal passes from the sound source(s) to the left and the right ear entrance of the listener (receiver). Using convolution techniques to convolve a mono signal with the BRIR, a binaural signal is obtained which, when played back over headphones should give the same listening experience as would be obtained in the real room. Mixing such binaural signals created with different source positions and signals, but with the same receiver position and orientation, multi channel simulations is possible (e.g. simulating a stereo setup, background noise versus loudspeaker announcements or singer versus orchestra).



Listening to Binaural Room Impulse Responses

As mentioned above, the basis of binaural auralization in ODEON is the BRIR's, which are calculated as a part of the Single Point Response. Once a Single point response is calculated, it is possible to play the BRIR, clicking the Play Single Point BRIR button. The BRIR may give a first clue as to how the room sounds and it also allows some evaluation of the quality of the calculated point response, e.g. whether to use a higher number of rays or a higher Reflection density in the Room setup.

Although the BRIR may sound a little 'rough', it may work quite realistic when convolved with a signal less transient than an ideal Dirac function. To get a more realistic presentation of a BRIR as it would sound in the real world you might want to convolve it with the Clapping signal file, an anechoic recording of hands being clapped, which is eventually a less transient signal than an ideal impulse.

A note on directivity patterns for natural point sources

With natural sources we refer to sources such as human voice, an acoustical instrument or similar, where a recorded signal for auralization may be associated with the directivity pattern. Directivity patterns for natural sources may be used for auralization of the very same signal it represents and if not handled correctly this will result in auralization where the overall frequency response is included not once but twice; first time through the directivity pattern which includes the overall frequency response, second time through the source signal, which inherently also include that response. For calculation of acoustical parameters it is desirable that the true frequency contents is included in the directivity pattern, e.g. to correctly estimate SPL or STI. However for auralization the directivity pattern should be equalised with the inverse spectrum of that of the front axis of the natural directivity pattern as this spectrum is already included in the source signal (i.e. the wave file with human voice recorded with a microphone at front axis).

Odeon 8.5 and later can manage to do both at the same time if only the source directivity is marked as natural, i.e. to create correct estimates of parameters from natural sources, while creating correct auralization, where the overall spectrum is only included once. Odeon is installed with some directivity patterns which have the word NATURAL attached to their names e.g. BB93_Normal_Natural.S08. When natural directivity patterns are selected from within Point source editor, a green natural label is displayed next to the equalization entry fields. If having existing directivity patterns of natural sources which are

not marked natural, this can be done using the Tool|Directivity patterns|Mark So8 file as natural directivity. When creating new directivity patterns this information is part of the input data.

Head Related Transfer Functions and digital filtering

To create binaural simulations, a set of HRTF's (see Appendix C; Vocabulary) is needed. The HRTF's are different from subject to subject and in principle you may measure your own ones and import those into ODEON using the Tools|Create filtered HRTF menu entry in the ODEON program. Measuring HRTF's is, however a complicated task so you will probably be using the supplied ones. If you should be interested in creating own sets of HRTF's for Odeon, additional information can be found in the help available from within the Odeon program.

The imported HRTF's to use for auralization are pre-filtered into octave bands in order to reduce calculation time. The octave band filter parameters for the selected filter bank can be seen on the filter bank name at the Auralization Setup menu. The filter parameters are:

M

The *M* value is taken into account if the Apply enhancement option is checked. If the file name contains the 'word' *Mddd* where *ddd* is a floating-point number, then localization enhancement was applied to the HRTF's [38]. This means that frequency dip and notches in the individual HRTF's has been exaggerated in order to improve the directional cues in the HRTF's. The *M*-factor determines how much the dips and notches has been exaggerated; If *M* is 0 then the effect is neutral, a value of 3.0 improves localization without too much undesired colouration. A *M* value greater than 3.0 does not seem to give any noticeable advantages whereas a value less than 3.0 give less colouration. The enhancement algorithms are further developments of those used in earlier versions of Odeon, as a result the *M* factor can be set as high as 3, allowing a significant improvement of the 3D experience through headphones without noticeable drawbacks.

A

When an *A* is appended after the *M*-factor, this tells that Minimize colouration effects (diffuse field approach) was not enabled so the HRTF were optimized for Anechoic conditions i.e. no reflections present. If no *A* is found in this place in the name then Odeon has attempted to Minimize colouration effects; The enhancements applied may give some colouration effects because some frequencies are amplified for individual directions. When this option is checked, Odeon will try to accomplish that colouration is kept at a minimum in a multi-reflection environment, that is, the average frequency response for all directions in the set of HRTF's is kept neutral.

Sample rate

The sample rate of the HRTF. This sample rate should be the same as the sample rate of the signal files (anechoic recordings) to be used. The supplied HRTF's are sampled at 44100 Hz.

Apass

Ripple of octave band filters in dB. Smaller is better, 0.5 dB is probably sufficient.

Astop

Maximum possible attenuation of octave bands. To allow complete attenuation of all reflections of a 16 bit signal (96 dB dynamic range), A_{stop} should be 96 dB, however due to auditory masking we are not able to hear such differences so 40 dB is probably sufficient. Smaller A_{stop} leads to shorter calculation time (of the BRIRs).

Band overlap in percent

Octave bands implemented using FIR filters are not completely rectangular, it takes some frequency span before they attenuates completely. An overlap between the filters of 100 percent gives a smooth transition between the filters, which is probably a more realistic representation of real world reflections than shorter overlaps. At the same time, long overlap gives shorter calculation time (of the BRIRs).

If you should need to use filters with other filter parameters e.g. A_{stop} being 96 dB you should create a filtered set of HRTF's with these parameters, use the File|Create filtered HRTF's option. Then from within your room, select the new filter bank from the Auralization Setup.

If you should need to import other HRTF's than the Kemar [32] (these HRTF's are installed, but does need to be imported) or Subject_021Res10deg [41] (Installed as well as imported), you should create a text file following the same format as used in the files Unity.ascii_hrtf, Kemar.ascii_hrtf and Subject_021Res10deg.ascii_hrtf. These files can be found in the \HeadAndPhone\EE\ and \HeadAndPhone\EC\ directories. To import a set of HRTF's, select the Tools|Create filtered HRTF's option, then select the specific

HRTF ASCII file e.g. C:\Odw\HeadAndPhones\EE\Kemar.ascii_hrtf, finally specify miscellaneous parameters when the import dialog appears – for help on these parameters please press F1 from within that dialog. You may also desire to import a set of HRTF which has already been imported in order to specify an alternative filtering approach e.g. to enhance the HRTF's in different ways.

Headphone filters

It is possible to compensate for non-linear frequency response of headphones. When a headphone is selected, Odeon will filter the output through a minimum phase filter with a frequency response inverse to that of the headphone. A number of headphone filters are supplied with Odeon in Odeon's .hph format. Filters ending on .ee.hph are measured on a dummy head at the entrance of a blocked ear canal whereas filters ending on .ec.hph are measured at the end of the ear canal (at the ear drum so to speak). The selected headphone filter should match the HRTF used; for example the Subject_021Res10deg.hrtf doesn't have an ear canal, therefore an .ee. filter should be used, whereas the Kemar.hrtf does have an ear canal, so the .ec. filters should be used. If the corresponding filter for the headphone used is not available then a generic filter matching the set of HRTF's may be used, e.g. Subject_021Res10deg_diffuse.hph. If a diffuse field filter (equalization) selected, the results are filtered in order to obtain an overall flat frequency response of the HRTF's; that is, the average frequency response of all the HRTF filters is calculated and the auralisation results are filtered with the inverse of that. If using headphones which are diffuse field equalized (most headphones attempt to be) and a matching headphone filter is not available, then the matching diffuse filter headphone filter can be used. For your convenience two directories with matching HRTF's and headphone filters are installed with ODEON namely the \HeadsAndPhones\EE\ and \HeadsAndPhones\EC\ directories. The first directory contains a set of HRTF's which was measured on a live subject with blocked ear-canal by the CIPIC Interface Laboratory [41] along with our matching .ee.hph headphone filters. The later contains the well known Kemar HRTF's, which includes ear-canals along with our matching .ec.hph filters. One of the directories can be selected in the Options|Program setup|Auralisation setup dialog – once this is done matching HRTF's and headphone filters can be selected in the same dialog as well as in the Auralisation setup specific to the individual room. If installing new HRTF's (or installing some of the additional CIPIC data from the installation disk, contained in the Additional_HRTF_data_for_Auditorium_and_Combined.zip file. Headphone filters are acceptable in the .wav format, in that case the filters should contain the impulse response(s) of the headphone as measured on a dummy head of the same type as the one selected in the HRTF drop down menu (i.e. with or without ear canal or a corresponding ear coupler). The filter may be one or two channels (two channel is desirable if compensating a specific headphone). A measuring program such as DIRAC [49] may be suitable for the measurement of the impulse response of a headphone. The creation of the inverse filter to be used is taken care of by ODEON.

Adjusting levels

Sound Pressure Level is one of the most important room acoustical parameters, so it is important that levels at which auralization samples are presented are realistic. If playing a simulation of voice at an unrealistic high level, the speech intelligibility may be over judged - it does not help that Clarity or Speech Transmission Index is satisfactory if the Sound Pressure Level is too low. If play back levels are too high, echo problems may be exaggerated, because echoes that would be below audible threshold (or at least at a very low level) are made audible.

The levels presented in auralization samples created by ODEON are influenced by:

- The HRTF's
- Level in input signal file, e.g. the RMS value or Leq_A
- Calculated Sound Pressure Level, which is based on geometry, sources, receiver positions, materials etc.
- Overall recording level in the Auralization setup
- Rcd. Lev. in the Auralization display of the JobList -if off-line convolution is used.
- Mixer levels (Mix. Lev. in the JobList) if off-line convolution is used.
- Gain in the Streaming convolution dialog if the real-time convolution option is used
- Output gain of the soundcard, the volume setting
- Sensitivity of the headphones
- Coupling between headphone and the subjects ear

Maximised play back levels for maximum dynamic range

If you are only interested in the best sound quality in your auralization files you may focus on getting an Output Level (Out Lev in the auralization display within the Job list) as close to but below 0 dB as possible in the Convolve BRIR and Signal file table and in the Mix convolved wave results into one wave file table in

order to obtain the highest dynamic range. If using the Streaming convolution option available from the main display in the Joblist, Odeon will maximize the auralization output level, if changing input signal or BRIR from within this display you may press the Maximize Gain button to maximize the gain for the new setup.

Relative play back levels

In some cases you'll be interested in obtaining correct relative levels e.g. for comparisons between different seats in a concert hall. In this case you should remember to use the same recording level (convolver level and mixer level) in the samples to be compared, it is a good idea to use the same input Signal file to make sure that levels are the same at this point. If you wish to compare across different rooms you should also be careful to remember that source gains in the rooms corresponds. If using the Streaming convolution option available from the main display in the Joblist, Odeon will maximize the auralization output level, so if you wish to compare different setups you should make sure to set the Gain in the Streaming convolution display to the same value.

Absolute play back levels for headphone auralization

Setting the level to an absolute level so the subject presented to the auralization sample experiences the same level as would have been the case in the real room is a bit tricky as it involves every part in the signal chain.

To obtain a reasonable correct level a first approach is to adjust the auralization output against levels of some kind of sound in the room in which you are, e.g. if you are simulating voice, try to compare the level of the playback with the level of somebody speaking in your room. This method should make it possible to make a rough adjustment - and it's certainly better than none.

A more precise method is to use the calculated SPL_A as a reference (if it is calculated at an absolute level):

- Present the auralization signal over a loudspeaker in the room in which you are sitting
- Measure the sound pressure level in the room at the position where you will be sitting when listening to the auralization and adjust the output level of the loudspeaker-amplifier until the measured Leq_A corresponds to the calculated level. At this point you have a physical reference level, which can be used for calibration of you auralization playback level
- Change between playing your auralization sample over headphones and over the loudspeaker while adjusting the level of the auralization playback until you are satisfied that the levels are the same.

This method is somewhat inspired by Bachausen and should at least in principle allow perfect calibration of the level (the resulting level being within one subjective limen).

Headphones

The binaural auralization results created in ODEON are binaural signals which should be presented over headphones, the objective being to reproduce the same sound pressure at the entrance of the ear canals (and at the eardrums for that matter) of the subject as would be obtained in the real room, if it exists).

Soundcards

A sound card is required in order to play back the auralization results and may also be useful if you wish to transfer (anechoic) signals to the harddisk. As a minimum the sound card should be capable of handling signals in stereo, in a 16-bit resolution at a sampling frequency of 44100 Hz. To transfer signals, without loss in quality to /from a DAT recorder the soundcard should be equipped with digital input and output and the soundcard should be able to handle a sampling frequency of 48000 Hz. It should also be considered whether the card is immune to electromagnetic noise, which is always present in a PC and whether its analogue output for headphones is satisfactory. (For surround Auralization, obviously a multi channel surround soundcards is needed along with the necessary loudspeakers and amplifiers).

Input signals for auralization - anechoic recordings

For auralization you will be using input signals to convolve with the calculated BRIR's. Usually the signals will be anechoic signals although it may also be other types of signals, e.g. if you are simulating an ordinary stereo setup in a room you will probably be using a commercial stereo recording. The input signals to be used with ODEON are stored in uncompressed wave files, having the well known .wav extension. Most, if not all, resolutions are supported, so files edited by programs such as CoolEdit or Adobe Audition can be used without any conversion being required:

- 8, 16, 24, 32 bit PCM
- 32 bit IEEE Float
- 8, 16, 24, 32 bit PCM, Extensible (tells the number of significant bits)
- 32 bit IEEE Float, Extensible (includes some additional info which is not used for input by ODEON)

To be compatible with the HRTF's supplied with ODEON the wave files should always be at a 44100 Hz sampling frequency.

The ODEON program comes with a few anechoic samples, which are installed to the `\odeon...\WaveSignals\` directory. If you wish to extend the library of input signals you should put your new signal files here or in a subdirectory to this directory e.g. `\odeon...\WaveSignals\English voice\` or `\odeon...\WaveSignals\NoiseSignals\`.

A few audio CD's containing anechoic recordings are commercially available, namely the Archimedes CD [36], which contains some recordings of solo instruments and the Denon CD [37] which contains (semi) anechoic stereo recordings of orchestral music. The easiest way to transfer recordings on an audio CD into wave files on the harddisk on a computer is probably to use a software application known as a CD ripper, this also ensures the transfer is without loss in quality. Signals 'ripped' from CD audio tracks, will always be in two channels - if you know that signals in fact are mono signals it will be a good idea to convert the resulting wave files into mono signals, this will save space on the harddisk and avoid confusion whether a signal is stereo or in fact mono. A standard wave file editing software, which is usually included with the soundcard should be capable of doing the job.

If you have recordings, which you have created yourself, e.g. using a DAT recorder, you should use a wave file recording software in connection with your soundcard in order to transform the recordings into wave files. Most soundcards comes with a software program for recording and editing wave files, which should be capable of this job. Please note that the connection between the CD-ROM drive and you soundcard is often an analogue one, so if you record from this drive you'll not benefit from digital inputs on your soundcard, resulting in a loss in quality.

Output signals

The output signals from all binaural auralization are stored in two channel wave files and will have the same leading name as the room. The result files, being in the wave format, makes it easy to edit and publish the results e.g. on the Internet or on audio CD's.

The binaural impulse responses files have the extension `.Jnn.Wav` where `nn` refer to the relevant job number.

The wave files created as results from the Convolve BRIR and Signal file table, will have the extension `.ConvAuralnn.Wav` where `nn` refer to the row in the table (Conv. no.).

The wave files created as results from the Mix convolved wave results into one wave file table will have the extension `.MixAuralnn.Wav` where `nn` refer to the row number in the table (Mix. No.).

The output from surround auralization follows rules similar to those of the binaural ones, the impulse responses are stored in wave files following the WaveFormatExtensible format where a signal is available for each loudspeaker /channel in the specified surround setup. The impulse response has the extension `.SurRoundnn.Wav` where `nn` refer to the relevant job number the convolved files have the extensions `.ConvSurRoundAuralnn.Wav` where `nn` refer to the row in the table (Conv. no.) and vice versa for the mixed files. These files should be playable using the Windows Media Player.

Publishing audible results on the Internet

To publish calculated demonstration examples on the Internet, it may be useful to convert the result wave files into compressed `.mp3` files or `.wav` Mpeg Layer3 files, as download times for wave files can be lengthy. One minute of compressed stereo signal will (depending on the compression rate) take up approximately 1 MB. If publishing examples, make sure that copyrights are not violated. You are free to publish examples, which are calculated using the anechoic examples supplied with ODEON, you may also redistribute the same anechoic examples for comparison. Remember to inform the end-user to use headphones when listening to the samples.

Publishing results on an ordinary audio CD

If a CD-R drive is installed on your PC is quite easy to transfer the wave result files into an ordinary audio CD (most CD-R drives comes with the necessary software for this purpose). Most people have

access to a CD audio player, so publishing results on an audio CD makes it easy to send demonstrations to clients etc. without worrying about whether they have a PC with a soundcard of a reasonable quality. Again when publishing examples, make sure that copyrights are not violated. You are free to publish examples, which are calculated using the anechoic examples supplied with ODEON, you may also redistribute the same anechoic examples for comparison. Remember to tell the end-user to use headphones when listening to the samples.

6 Calculation Principles

6.1 Global decay methods

ODEON features two methods for calculating the Global decay of rooms:

- Quick Estimate, which is available from the Materials List, is the fastest method allowing quick evaluation of the effect of changes to materials. This method should be considered only as a tool for preliminary results.
- Global Estimate is the most precise of the methods allowing high quality results.

6.2 Quick Estimate

This method estimates a mean absorption coefficient, which is inserted in the Sabine, Eyring and Arau-Puchades formulas to give an estimate of the reverberation time. Instead of simply taking the areas of the surfaces and multiplying by the corresponding absorption coefficients to obtain the total absorption in the room, ODEON also sends out 'particles' from the source, assuming diffuse conditions thus reflecting them in random directions, keeping a count on how many times they hit each surface. Surfaces that are hit very often then carry greater weight in the overall mean absorption coefficient of the room. Surfaces, which are not detected at all in the ray-tracing process, are left out of all calculations and surfaces which are hit on both sides are included twice in the calculation. As a result the estimated reverberation time corresponds to the sub-volume in which the selected source is located. Note however that if a part of the area of a surface, which is present in the sub-volume, is located outside that sub-volume (e.g. if two sub-volumes share the same floor surface) then area and surface estimates for the statistical calculations may not be entirely correct.

The classical mean absorption coefficient is given by:

$$\bar{\alpha} = \frac{\sum_i S_i \alpha_i}{\sum_i S_i}$$

where S_i and α_i are respectively the area and absorption coefficient of the i^{th} room surface.

The modified mean absorption coefficient as experienced by the particles is:

$$\bar{\alpha}' = \frac{\sum_i H_i \alpha_i}{\sum_i H_i}$$

where H_i is the number of hits on the i^{th} room surface.

In ODEON, both of these mean absorption coefficients are inserted in the Sabine and Eyring formulae to calculate reverberation times; the classical values are labelled Sabine and Eyring, and the values using the modified mean absorption coefficient are labelled Modified Sabine and Modified Eyring. The mean absorption coefficients used for the Arau-Puchades formula are derived in similar ways except that separate values for surface hits, area and the corresponding mean absorption coefficients are calculated as projections onto each of the main axis of the room.

The Sabine, Eyring and Arau-Puchades formulae require a value for the room volume, which ODEON estimates from the mean free path experienced by ray tracing, using the well-known relation:

$$l = \frac{4V}{S}$$

where V is the room volume and S the total active surface area. From version Odeon 6.5, the ray-tracing process carried out in order to estimate the room volume assumes scattering coefficients of 1 for all surfaces rather than using the coefficients assigned to the surface in the materials list as this is the mean free path formula is based on diffuse field assumptions.

The value of S used here is the sum of the areas of non-transparent surfaces, taking into account whether one, two or indeed none of the sides of a surface are visible inside the room.

Convergence criterion

A certain number of particles must be sent out and followed around the room for a stable estimate to be obtained. More and more particles are sent out in random directions until the value of the reverberation time has remained within 1% for at least 50 particles. At the end of a run, the data on how many times each surface was hit is stored. Then, if new materials are assigned to the surfaces, the reverberation times can be recalculated instantaneously, without repeating the particle tracing.

6.2.1 Global Estimate

This method estimates the global reverberation times T_{20} , T_{30} using the method proposed by Schröder [48], the room volume, and the mean free path and generates estimates of decay curves. Particles are sent out in random directions from the source (see section 6.7) and reflected using the 'Late ray' reflection method (see section 6.4). ODEON records the loss of energy in each particle as a function of time occurring because of absorption at room surfaces and in the air. Summing over many particles, a global energy decay function for the room is obtained. The decay curve is backwards integrated and a correction for energy, which is lost due to the truncation of the decay curve, is applied. This is analogous to an ordinary decay curve, except there is no specific receiver. The summation process may be carried on for as long as desired.

Evaluating results

When the reverberation curve seems smooth, derive the results. If T_{30} values are shorter than T_{20} it is likely that the number of rays used were too small, thus press the Recalculate button. If the reverberation times are 0, the Impulse response length defined at the Room Setup page is probably too short.

6.3 Calculation of Response from Sources to Receivers

This section describes the methods used to predict the response from a source to a receiver. This is the process used to in order to predict Single Point, Multi Point and Grid Response results from within the Job list.

Source types - calculation methods

Responses from point sources are calculated using a hybrid calculation method, where the 'early reflections' are calculated using a mixture of the Image source model and ray-tracing and the late reflections are calculated using a special ray tracing process generating secondary sources which radiates energy locally from the surfaces of the walls. Responses from line and surface sources are carried out using the special ray-tracing method.

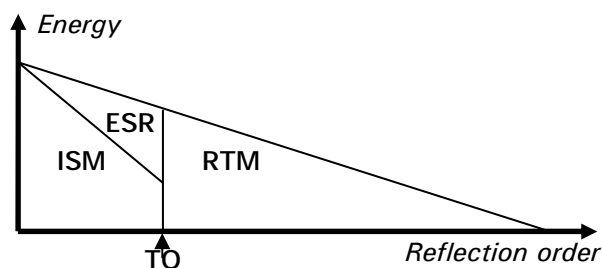

The calculations carried out are divided into a two-step process, a receiver independent part and a receiver dependent part.

Trace-rays - the receiver independent part

Trace-rays is the receiver independent part of the Response calculations; rays are being used to trace down possible reflection paths; the result of this process can be reused for any receiver position in the room. Whenever running a Single Point, Multi Point and Grid Response calculation, the necessary Trace-rays calculation is automatically carried out, if this has not been done already. For point sources rays distributed equally in all directions on a sphere, for line and surface sources the rays are sent out in

random directions following the Lambert distribution (see section 6.7 Sending rays from a source). Once sent from a source, rays are followed around the room as they become reflected and the geometrical data is stored (id numbers of walls hit, points of incidence, etc.). The criterion for stopping the trace of a given ray is normally a geometric one, either the path length travelled (set by the Impulse Response Length) or number of reflections experienced (Max. reflection order). The geometrical data produced, is written continuously to the hard-disk, and used later in the determination of reflections received at a point. The early reflections of rays from point sources are treated a little bit different from the rest of the rays because they are reflected specularly, if the reflection order is less or equal to the Transition order allowing the detection of image sources. Above this order the rays are reflected due to the 'Late ray' (see section 6.4) method of ODEON.

Single Point, Multi Point and Grid Response - the receiver dependent part

Having traced rays around the room and stored the data of ray-histories, the next step is to place the receiver at a specific point and so to speak 'collect' the reflections there. These point response calculations are the receiver dependent part of the calculations; at this point the contributions of direct and reflected sound are collected at the receiving point allowing the calculation of the results known as Single Point, Multi Point and Grid Response.

When more than one receiver is involved, the receiver-dependent part of the process is simply repeated for each source. When more than one source is involved, the response at a given receiver is simply the sum of the responses from the individual sources, each delayed appropriately, if a delay is applied to the source.

ODEON automatically takes care of handling which of the calculation and result files are currently consistent with user-entered data, erasing those that are no longer valid. Thus in some situations you may experience that Trace Rays calculation files have already been done/ are still valid, in other cases they have to be recalculated.

The Early Reflection method

Early reflections in ODEON are reflections generated by point sources while the reflection order is less than or equal to the Transition order specified in the Room setup. Every time a ray is reflected at a surface the position of an image source, which may or may not give a contribution to the response at the receiver, is found. The position of this image is defined by the incident direction and the path length travelled from the source to the surface (via other surfaces, in the case of higher order reflections). ODEON checks each image source to determine, whether it is visible from the receiver. Images may be hidden because walls in the room block the reflection path to the receiver or because the receiver falls outside the 'aperture' formed between the image source and the surface generating it. Figure 1 illustrates the concept of visible and hidden image sources. If an image is found to be visible, then a reflection is added to the reflectogram, if another ray has not already detected it. In this 'early' part of the point response calculation, rays are only used indirectly to detect Image sources that are likely to be valid. From Odeon version 4.2 the Image sources are split into a specular contribution and a 'scattering tree', which consists of secondary sources on the image source surfaces allowing a realistic calculation of early scattering. The attenuation of a particular Image source is calculated taking the following into account:

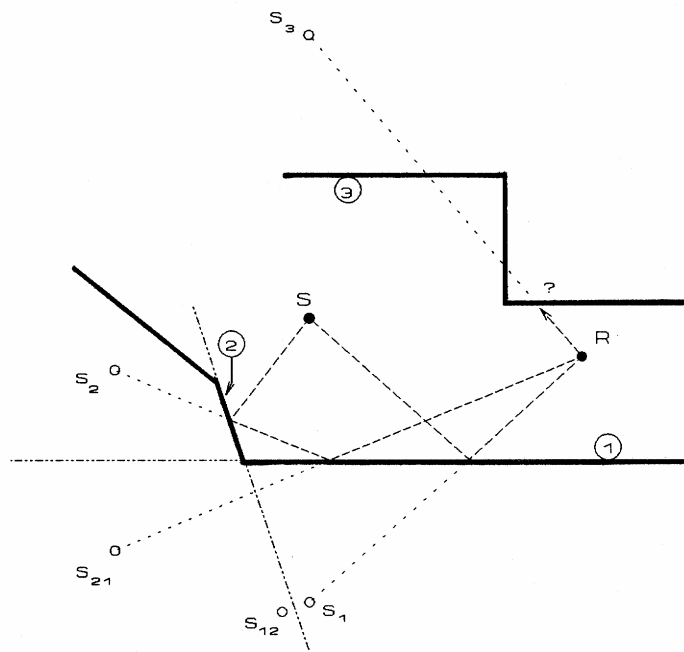

Figure 1. Visible and invisible images. Images S1 and S12 are visible from R, while S2, S3 and S12 are not.

- Directivity factor of the primary source in the relevant direction of radiation
- Reflection coefficients of the walls involved in generating the image
- Air absorption due to the length of the reflection path
- Distance damping due to the distance travelled from the primary source to the receiver
- Scattering loss (frequency dependent), due to the scattered energy which is handled by a 'scattering tree'. Scattering may occur because of surface roughness as specified by the scattering coefficients in the materials list or due to limited surface dimensions or edge diffraction.

Early scattering

In short, each time Odeon detects an image source, an inner loop of (scatter) rays (not visualised in the 3D Investigate Rays display) is started, taking care of the scattered sound which is reflected from this image source /surface.

Example: If all scattering coefficients in a room is 0.5, then the specular energy of a first order IMS is multiplied (1-0.5) - and the specular energy of a second order IMS is multiplied by (1-0.5)*(1-0.5). The scattering rays handle the rest of the energy.

The early scatter rays are handled in a way, which is indeed inspired by the way in which Odeon simulates surface sources, actually each time an image source is detected, Odeon will simulate a surface source, which will emit Number of early scatter rays times the scattering coefficient of the image source surface. The early scatter rays will be traced from the current reflection order and up to the transition order. At each reflection point of the early scattering rays, including the starting point, a secondary scattering source is created.

The Late Reflection method

All reflections that are not treated by the early reflection method are treated by the late reflection method. Every time a late ray is reflected at a surface, a small secondary source is generated. This secondary source may have a Lambert, Lambert Oblique or Uniform directivity depending on the properties of the reflection as well as the calculation settings. ODEON checks each secondary source to determine, whether it is visible from the receiver. The late reflection process does not produce an exponential growing number of reflections (with respect to the time) as would be expected in the real room, but keeps the same reflection density in all of the calculation in order to keep down calculation times.

The attenuation of a secondary source is calculated taking the following into account:

- Directivity factor of the primary source in the relevant direction of radiation (point sources only)
- Reflection coefficients of the walls involved in generating the image
- Air absorption due to the length of the reflection path
- Distance damping due to the distance travelled from the primary source to the receiver is inherently included in the ray-tracing process.
- Directivity factor for secondary sources e.g. the Lambert, Oblique Lambert or Uniform directivity, see later.

Summarising the calculation method used for point response calculations in ODEON

As described above, the point response calculation in ODEON is divided into a receiver independent and a receiver dependent calculation part. The division into two calculations is solely done in order to save calculation time by reusing parts of the calculation where possible.

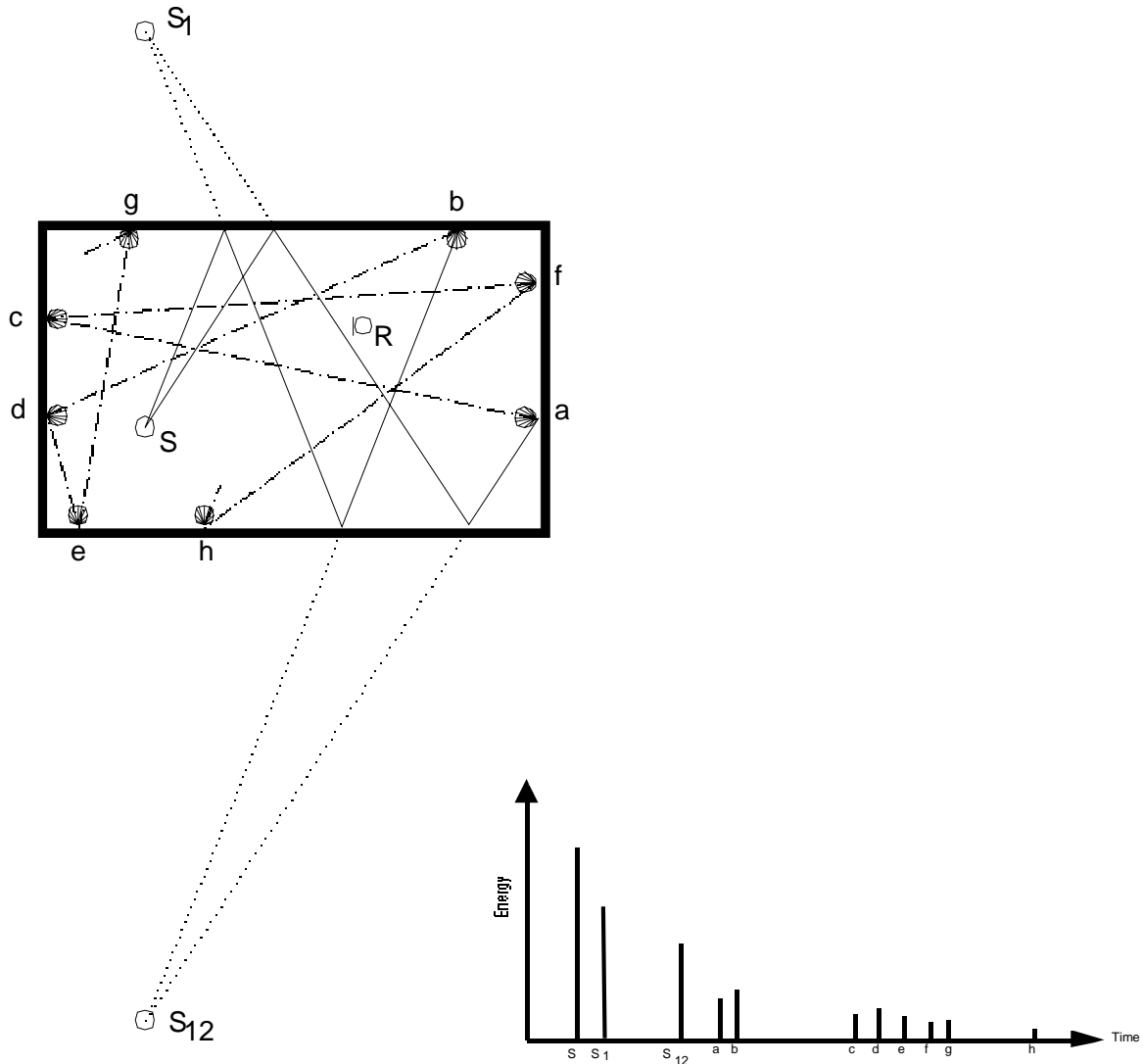

Figur 2. Summary of the model for response calculations. Inset shows resulting reflection sequence at receiver R.

Looking at the calculation as a whole, only with respect to one receiver may help understanding the concept. In figure 2 reflections generated by a point source at a certain receiver is illustrated, taking into account only two neighbouring rays up to the sixth reflection order. Because we are dealing with a point source, this figure illustrates the hybrid calculation method. The calculation is carried out using a Transition order of 2 and all surfaces are assigned Scattering coefficients of 1. Thus rays will detect image sources up to second order and above this order they will detect secondary sources.

Both rays detect the image sources, which will both contribute a reflection to the receiver, because the specular reflection path between the source and the receiver is free and reflection points falls within the boundaries of the surfaces.

Although more than one ray detected the image sources they only contribute the detected image sources once, this is obtained by having ODEON build an Image tree keeping track on this. Each Image source being unique is one of the major advantages of the Image source model.

Above order 2, each ray generates independent secondary sources situated on the surfaces of the room. The time of arrival of the contribution from a given secondary source is proportional to the ray path length from S to the secondary source plus the distance from the secondary source to the receiver. The intensity of a contribution from a secondary source is attenuated as listed above.

One of the advantages of the ray tracing method used in ODEON compared to more traditional methods is that rays do not even have to come near to the receiver to make a contribution. Thus even in coupled room, it is possible to obtain a reasonably number of reflections at a receiver (which is required to obtain a result that is statistically reliable) with only a modest number of rays. This results in a fine balance between reliability of the calculation results and calculation time.

A complete histogram containing both early and late energy contributions is generated and used to derive Early Decay Time and Reverberation Time. The other room acoustical parameters are calculated on basis of energy collected in time and angular intervals.

For surface and line sources a number of secondary sources are placed randomly on the surface of the source, each emitting one ray and radiating a possible contribution to the receiver. The rays emitted from these source types generate an independent secondary source each time they are reflected. Compared to the calculation principle applied to the point sources one might say that only late energy contributions are collected for these source types or rather that calculations are based on a sort of ray tracing.

6.4 The 'Late ray' reflection method of ODEON

The 'Late ray' reflection method is applied for all rays used in Quick Estimate and Global Estimate. For point response calculations, rays sent out from a line or a surface use the 'Late ray' reflection method from the first reflection of a ray (reflection order); rays sent from a point source is handled a little different; in order to combine with the hybrid calculation method, rays are reflected specular as long as the reflection order is less or equal to the Transition order specified at the Room Setup dialog, this is done in order to allow the detection of image sources up to the specified order, above this order the rays are reflected using the 'Late ray' reflection method.

Vector Based Scattering - reflecting a 'Late ray'

Vector based scattering is an efficient way to include scattering in a ray-tracing algorithm. The direction of a reflected ray is calculated by adding the specular vector Snell's⁸ law, scaled by a factor $(1-s)$ to a scattered vector (random direction, following the angular Lambert distribution of ideal scattered reflections; $\sin^2\theta$

[2]) which has been scaled by a factor s where s is the scattering coefficient. If s is zero the ray is reflected in the specular direction, if it equals 1 then the ray is reflected in a random direction. Often the resulting scatter coefficient may be in the range of say 5 to 20% and in this case rays will be reflected in directions which differ just slightly from the specular one but this is enough to avoid artifacts due to simple geometrical reflection pattern.

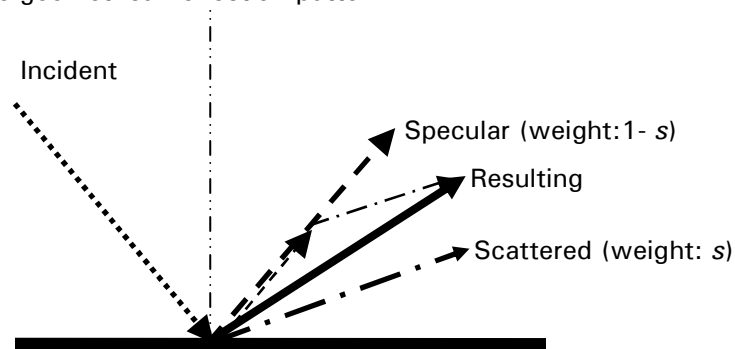

Figur 3. Vector based scattering. Reflecting a ray from a surface with a scattering coefficient of 50% results in a reflected direction which is the geometrical average of the specular direction and a random (scattered) direction. Note: Scattering is a 3D phenomena, but here shown in 2D.

6.5 The Reflection Based Scattering coefficient

When the reflection based scattering coefficient is activated in the room setup ODEON will do its best in estimating the scattering introduced due to diffraction whether it occurs due to the limited size of surfaces or as edge diffraction. When the method is activated, the user specified scattering coefficients assigned to the surfaces should only include scattering which occur due to surface roughness, diffraction phenomenon's are handled by ODEON. The Reflection based scattering method combines scattering caused by diffraction due to typical surface dimensions, angle of incidence,

⁸ Snells law is the law of Billiard saying that the reflected angle equals the angle of incidence

incident path length and edge diffraction with surface scattering. Each of the two scattering effects is modeled as frequency dependent functions. The benefits are two-fold:

- Separating the user specified surface scattering coefficient from the room geometry makes it easier for the user to make good estimates of the coefficients that will be in better agreement with the ones that can be measured. In many cases a scattering coefficient of say 5% for all smooth surfaces may be sufficient.
- Scattering due to diffraction is distance and angle dependent and as such it is not known before the source and receiver are defined, and the actual 'ray-tracing' or image source detection takes place. An example on this is that a desktop may provide a strong specular component to its user whereas it will provide scattered sound at remote distances.

The method has several advantages, not only does it make life easier because the same scattering coefficient can be used for different surfaces, no matter their size, it also allow better estimate of the actual scattering occurring at a reflection point, because scattering caused by diffraction is not fully known, before the actual reflections are calculated thus angles of incidence, path-lengths etc. are known. In order to allow these features to be included in predictions, the reflection based scattering coefficient s_r combining the surface roughness scattering coefficient s_s with the scattering coefficient due to diffraction s_d is calculated individually for each reflection as calculations take place:

$$s_r = 1 - (1 - s_d) \cdot (1 - s_s)$$

The formula calculates the fraction of energy which is not specular when both diffraction and surface roughness is taken into account. $(1-s_d)$ denotes the energy which is not diffracted, that is, energy reflected from the surface area either as specular energy or as surface scattered energy, the resulting specular energy fraction from the surface is $(1-s_d) \cdot (1-s_s)$.

s_s Surface scattering

Surface scattering is in the following assumed to be scattering appearing due to random surface roughness. This type of scattering gives rise to scattering which increase with frequency. In figure 4 typical frequency functions are shown. In ODEON these functions are used in the following way: Specify scattering coefficients for the middle frequency around 700 Hz (average of 500 – 1000 Hz bands) in the materials list, then ODEON expands these coefficients into values for each octave band, using interpolation or extrapolation.

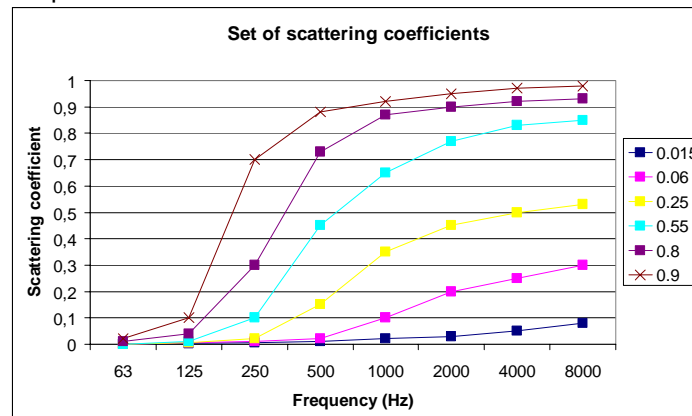

Figure 4: Frequency functions for materials with different surface roughness. The legend of each scattering coefficient curve denotes the scattering coefficient at 707 Hz.

At present it has not been investigated in depth which scattering coefficient (at the mid-frequency 707 Hz) should be used for various materials. However initial investigations indicate that the following magnitudes may be sound.

Material	Scattering coefficient at mid-frequency
Audience area	0.6–0.7
Rough building structures, 0.3–0.5 m deep	0.4–0.5
Bookshelf, with some books	0.3
Brickwork with open joints	0.1–0.2
Brickwork, filled joints but not plastered	0.05–0.1
Smooth surfaces, general	0.02–0.05
Smooth painted concrete	0.005–0.02

Table 1. Suggested scattering coefficients to use for various materials. The given values are for the middle frequency at around 700 Hz to be assigned to surfaces in ODEON. Suggestions may be subject to changes as more knowledge on the subject is obtained.

s_d Scattering due to diffraction

In order to estimate scattering due to diffraction, reflector theory is applied. The main theory is presented in [5,6], the goal in these papers was to estimate the specular contribution of a reflector with a limited area; given the basic dimensions of the surface, angle of incidence, incident and reflected path-lengths. Given the fraction of the energy which is reflected specularly we can however also describe the fraction s_d which has been scattered due to diffraction. A short summary of the method is as follows: For a panel with the dimensions $l \cdot w$; above the upper limiting frequency f_w (defined by the short dimension of the panel) the frequency response can be simplified to be flat, i.e. that of an infinitely large panel, below f_w the response will fall off with by 3 dB per octave. Below the second limiting frequency f_l , an additional 3 dB per octave is added resulting in a fall off by 6 dB per octave. In the special case of a quadratic surface there will only be one limiting frequency below which the specular component will fall off by 6 dB per octave. The attenuation factors K_l and K_w are estimates to the fraction of energy which is reflected specularly. These factors takes into account the incident and reflected path lengths (for ray-tracing we have to assume that reflected equals incident path length), angle of incidence and distance for reflection point to the closest edge on the surface all information which is not available before the calculation takes place.

$$K_w = \begin{cases} 1 & \text{for } f > f_w \\ \frac{f}{f_w} & \text{for } f \leq f_w \end{cases}, \quad K_l = \begin{cases} 1 & \text{for } f > f_l \\ \frac{f}{f_l} & \text{for } f \leq f_l \end{cases}$$

$$f_w = \frac{c \cdot a^*}{2 (w \cdot \cos \theta)^2}, \quad f_l = \frac{c \cdot a^*}{2 \cdot l^2}$$

$$\text{where } a^* = \frac{d_{inc} \cdot d_{refl}}{2 (d_{inc} + d_{refl})}$$

If we assume energy conservation, then we must also assume that the energy which is not reflected specularly has been diffracted - scattered due to diffraction. This leads to the following formulae for our scattering coefficient due to diffraction:

$$s_d = 1 - K_w K_l \times (1 - s_e)$$

In order to compensate for the extra diffraction which occurs when a reflection appears close to an edge of a free surface, the specular component is reduced by a factor $1 - s_e$. The edge scattering coefficient is defined to be 0.5 if the reflection occurs at the edge of a surface saying that half of the energy is scattered by the edge and the other half is reflected from the surface area. If the reflection point is far from the edge, the edge scattering becomes zero - initial investigations suggests that edge scattering can be assumed to zero when the distance to the edge is greater than approximately one wave length, therefore we define the edge scattering coefficient as:

$$s_e = \begin{cases} 0 & \text{for } d_{edge} \times \cos \theta \geq \frac{c}{f} \\ 0.5 \left(1 - \frac{d_{edge} \times \cos \theta \times f}{c} \right) & \text{for } d_{edge} \times \cos \theta < \frac{c}{f} \end{cases}$$

As can be seen, scattering caused by diffraction is a function of a number of parameters of which some of them are not known before the actual calculation takes place. An example is that oblique angles of incidence leads to increased scattering whereas parallel walls leads to low scattering and sometimes flutter echoes. Another example is indicated by the characteristic distance a^* , if source or receiver is close to a surface, this surface may provide a specular reflection even if its small, on the other hand if far from away it will only provide scattered sound, $s_d \approx 1$.

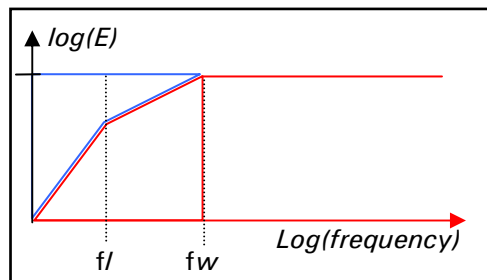

Figure 5. Energy reflected from a free suspended surface given the dimensions $l \cdot w$. At high frequencies the surface reflects energy specularly (red), at low frequencies, energy is assumed to be scattered (blue). f_w is the upper specular cut off frequency defined by the shortest dimension of the surface, f_l is the lower cutoff frequency which is defined by the length of the surface.

Boundary walls and interior margin

As long as surfaces are truly freely suspended surfaces, they will act as effective diffusers down to infinitely low frequencies. For surfaces which are elements in the boundary of the room; such as windows, doors, paintings, blackboards etc. one should however not expect these elements to provide effective scattering down to infinitely low frequencies. From diffuser theory [] it is found that typical behaviour is that the effectiveness of a diffuser decreases rapidly below a cut-off frequency which can roughly be defined from the depth of the diffuser (wall construction) being less than half a wave length. Two octave bands below the cut-off frequency the diffuser is no longer effective. At the lowest frequencies however, the dimensions of the room will provide some diffraction, therefore the dimensions of the reflecting panel as used in the formulae for f_l and f_w is substituted with the approximate dimensions of the room at the lowest frequencies and a combination of surface and room dimensions are used for frequencies in-between high and low frequencies. It is worth noticing that it is not only the depth of the wall construction which enables the elements of the wall construction to provide diffraction, also angling between the surfaces, offsets e.g. the door being mounted in a door hole or the surfaces being made of different materials provides the phase shifts which results in diffraction. Therefore it may be reasonable to assume that the boundary walls have a minimum depth of say 10 cm in order to account for such phase shifts. The typical depth of a geometry's wall construction should be specified in the Interior margin in the room setup. Odeon will use this number in order to distinguish between interior and boundary surfaces. Once the margin has been entered and the room setup dialog has been closed the 3DView will display surfaces which is considered to be interior in a greenish colour while the exterior is displayed in black. Diffraction from the exterior will be calculated taking into account that diffraction is limited towards the lowest frequencies because of limited depth of the wall constructions.

Limitations

In special cases the *Reflection Based Scattering Coefficient* may overestimate the scattering provided by small surfaces which are only fractions of a bigger whole e.g. small surfaces being part of a curved wall or dome. Such surfaces should not cause diffraction due to their individual area because the individual surfaces do not provide any significant edge diffraction. In these cases the method can be bypassed by setting the surface Type to Fractional in the MaterialsList, see chapter 4. When setting the Type to Fractional, the surface area used for calculating the *Reflection Based Scattering Coefficient* is determined

from the box subscribing the room rather than the individual surface - if the construction part which the fractional surface is part of, is considerable smaller than the 'room box' scattering might be underestimated and a higher scattering coefficient should be assigned to the surface.

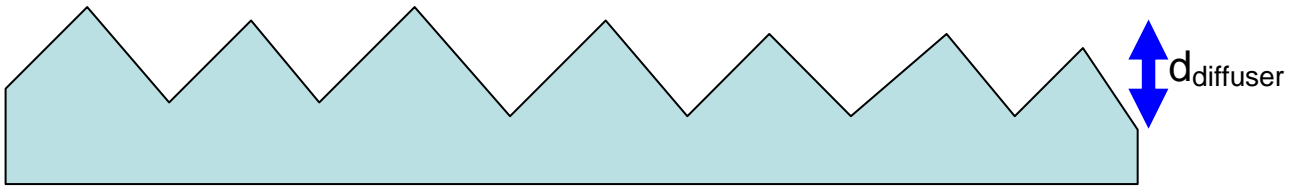
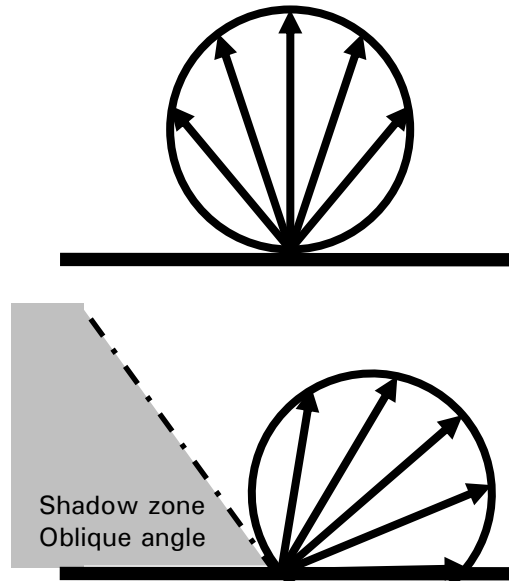

Figure 6. A typical diffuser depth (interior margin) entered by user determines which parts of the geometry should be considered exterior of a room, thus limiting the scattering of the boundary surfaces which can not be considered freely suspended at the lowest frequencies.

6.6 Oblique Lambert

In the ray-tracing process, a number of secondary sources are generated at the collision points between walls and the rays traced. It has not been covered yet which directivity to assign to these sources. A straight away solution which is the one Odeon has been applying until now is to assign Lambert directivity patterns, that is, the cosine directivity which is a model for diffuse area radiation. However the result would be that the last reflection from the secondary sources to the actual receiver point is handled with 100% scattering, no matter actual scattering properties for the reflection. This is not the optimum solution, in fact when it comes to the last reflection path from wall to receiver we know not only the incident path length to the wall also the path length from the wall to the receiver is available, allowing a better estimate of the characteristic distance a^* than was the case in the ray-tracing process where d_{refl} was assumed to be equal to d_{inc} . So which directivity to assign to the secondary sources? We propose a directivity pattern which we will call *Oblique Lambert*. Reusing the concept of *Vector based scattering*, an orientation of our Lambert sources can be obtained taking the *Reflection Based Scattering* coefficient into account. If scattering is zero then the orientation of the *Oblique Lambert* source is found by Snell's Law, if the scattering coefficient is one then the orientation is that of the traditional Lambert source and finally for all cases in-between the orientation is determined by the vector found using the *Vector Based Scattering* method.



Figur 7. Traditional Lambert directivity at the top and Oblique Lambert at the bottom. Oblique Lambert produces a shadow zone where no sound is reflected. The shadow zone is small if scattering is high or if the incident direction is perpendicular to the wall. On the other hand if scattering is low and the incident direction is oblique then the shadow zone becomes large.

If *Oblique Lambert* was implemented as described without any further steps, this would lead to an energy loss because part of the Lambert balloon is radiating energy out of the room. In order to compensate for this, the directivity pattern has to be scaled with a factor which accounts for the lost energy. If the angle is zero the factor is one and if the angle is 90° the factor becomes its maximum of two because half of the balloon is outside the room. Factors for angles between 0° and 90° have been found using numerical integration.

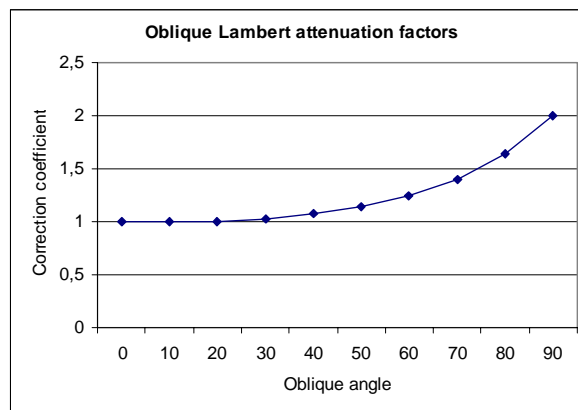

Figure 8. Correction factor for *Oblique Lambert*. When the oblique angle is zero, *Oblique Lambert* corresponds to traditional Lambert and the correction coefficient is one. When the oblique angle is 90° corresponding to grazing incidence on a smooth surface, the correction factor reaches its maximum of two.

A last remark on *Oblique Lambert* is that it can include *frequency depending scattering* at virtually no computational cost. This part of the algorithm does not involve any ray-tracing which tends to be the heavy computational part in room acoustics prediction, only the orientation of the *Oblique Lambert* source has to be recalculated for each frequency of interest in order to model scattering as a function of frequency.

6.7 Sending rays from a source

In ODEON (Combined and Industrial version only) there different kind of sources are available; the point, the line and the surface source. Knowing a little bit about how ray directions and starting points are generated by ODEON may avoid confusion, and help using tools like 3D Investigate Rays at its optimum.

Point Sources

For Single, Multi and Grid response calculations and for the 3D Investigate Rays display, rays are sent in directions distributed as evenly as possible over a solid angle. Ray directions are arranged in rings and ray 1 is sent out almost vertically downwards and the last ray is sent almost vertically upwards. The total number of rays used is usually a few more or less than requested to ensure an even distribution. For Quick Estimate and Global Estimate the send directions are chosen randomly allowing the calculation to be finished after any ray without getting a very uneven distribution of send-directions.

Surface Sources and Line sources

(Combined and Auditorium versions only)

For these source types the send directions and send points are the same no matter the calculation type. For each starting ray a random starting point is chosen at the line or surface source. From this point a ray is send out in a direction following the laws of the 'Late ray' method using a specular direction based on the 'Normal' of the source and a scattered direction. The method used here is similar to the 'Late ray' reflection method of ODEON, however the scattering coefficient used for weighting between the normal direction of the source and the scattered direction is one assign to the particular source from within the appropriate source editor (Line Source Editor or Surface Source Editor). With the present knowledge a scattering coefficient of 1 is suggested for these source types.

6.8 Processing reflection data for auralization use in Single Point Response Calculations

A typical point response calculation in ODEON includes some 100000 reflections per source /receiver. The reflections are calculated in terms of time of arrival, strength in 8 octave bands and angle of incidence (azimuth and elevation). The information on size of the reflecting surfaces and absorption coefficients are also available as a part of the calculation.

Binaural filters for headphone playback: When the Auralization setup|Create binaural impulse response file option is turned on reflections are processed in order to create a binaural impulse response (BRIR). First of all it is determined whether a phase shift should be applied to the reflection, based on surface size and absorption coefficients of the last reflecting surface [31]. Then the reflection is filtered /convolved through 9 octave band filters (Kaiser-Bessel filters, the ninth being extrapolated) and finally the reflection is filtered /convolved through two corresponding directional filters, one for each ear (Head Related Transfer Functions), creating a binaural impulse response for that reflection. This process is carried out for each reflection received at the receiver point and superposing all the reflections, a resulting Binaural Room Impulse Response (BRIR) for that particular receiver point is obtained. The actual order in which the filtering is carried out in ODEON differs somewhat from the description above (otherwise the calculation time would be astronomic), but the resulting BRIR contains the full filtering with respect to octave band filtering in nine bands as well as directional filtering.

B-format filters for external decoding and Surround filters for loudspeaker playback: Calculation of these impulse responses are based on the Ambisonics technique which is covered in [43-46]. Most of the Odeon specific steps involved in the generation of these filters are similar to those used for generation of BRIR's, there are however two differences; HRRF's are not used in this calculation which is aimed at loudspeaker representation where the listener will receive reflections from own head and torso. The other difference is that reflections are added with random phase.

6.9 Calculation method for Reflector Coverage

25000 rays are send out from the selected source, if the rays hit one of the surfaces defined as reflector surfaces at the Define reflector surfaces menu, a cross is painted where the reflected rays hits the

room surfaces. Note that the value of the Transition order is taken into account; if it is zero and the Lambert scattering is active, the chosen reflectors will exhibit a degree of scattered reflection corresponding to their scattering coefficients. Sound from line and surface sources will always reflect scattered, if the Lambert scattering is on.

7 Calculated Room Acoustical parameters

This chapter will shortly describe the derivation of energy parameters for Single Point, Multi Point and Grid response calculations (for the Industrial edition only EDT, T_{30} , SPL, SPL_A and STI are available). All the parameters are derived on the assumption that the addition of energy contributions from different reflections in a response is valid. This manual will not cover the use of the individual parameters in depth and suggestions on ideal parameters choice should only be sought of as a first offer; instead refer to relevant literature e.g. some of the following references for a further discussion on parameters and design criterions:

Auditorium acoustics as Concert Halls, Opera Halls, Multipurpose halls, etc. are dealt with in [26] and [27], where different halls around the world are presented along with judgement of their acoustics and guidelines for design.

Short guidelines on which values to expect for Clarity and G in concert halls based on some simple design parameters as width, height, floor-slope, etc. are given in [28].

Some recommended values for room acoustical parameters

Objectiv parameter	Symbol	Recommended (symphonic music)	Subj. limen
Reverberation time	T_{30}	1.7 - 2.3 seconds	5 %
Clarity	C_{80}	- 1 to 3 dB	5 %
Level rel. 10 m free field	G	> 3 dB	1 dB
Early Lateral Energy Fraction	LF_{80}	> 0.25	5 %
Early Support	ST_{early}	> -13 dB	
Total Support	ST_{total}	> - 12 dB	

Recommended values for ISO 3382-1 objective room acoustical parameters [6] in large music rooms with audience according to Gade [24]. Subjective limen as given by Bork [39] and Bradley [40].

Early Decay Time and Reverberation time

The energies of all the reflections received at the receiver point are collected in histograms, with class interval specified in the Room setup |Impulse response resolution. After completion of the response calculation, early decay time and the reverberation time are calculated according to ISO 3382 [6]:

The Reverberation time T_{30} is calculated from the slope of the backwards-integrated octave band curves. The slope of the decay curve is determined from the slope of the best-fit linear regression line between -5 and -35 dB, obtained from the backwards-integrated decay curve.

Early Decay Time (EDT) is obtained from the initial 10 dB of the backwards-integrated decay curve.

Sound Pressure Level, Clarity, Deutlichkeit, LF, ST_{early} , ST_{late} and ST_{total}

The energy of each reflection is added to the appropriate terms in the formulas for all the energy parameters, according to its time and direction of arrival. After the response calculation, Clarity, Deutlichkeit, Centre Time, Sound Pressure Level, Lateral Energy Fraction, ST_{early} , ST_{late} and ST_{total} is derived.

In the following formulae, E_{a-b} is the sum of energy contributions between time a and time b after the direct sound, time t is the end of the calculated response, and t is, for the reflection arriving at time t , the angle between the incident direction and the axis passing through the two ears of a listener.

Below two definitions are shown for Clarity, Deutlichkeit, Lateral Energy Fraction, ST_{early} , ST_{late} and ST_{total} , corresponding to the Room Setup|Calculation parameters|Smooth early late ratios option being checked or not. The smoothing is turned on by default. The averaging is equivalent to a 'smoothing' of the transition between 'early' and 'late' energy, and attempts to make up for the facts that:

- Reflections in ODEON are point-like in time, but in reality they are smeared out both physically and by filtering during measurement.
- Inaccuracies in geometrical modeling lead to inevitable displacements of reflections backwards and forwards from their 'true' positions.

Clarity (Early-late averaging OFF):

$$C_{80} = 10 \log \left(\frac{E_{0-80}}{E_{80-\infty}} \right) \quad (dB)$$

Clarity (Early-late averaging ON):

$$C_{80} = 10 \log \left(\frac{E_{0-72} + E_{0-80} + E_{0-88}}{E_{72-\infty} + E_{80-\infty} + E_{88-\infty}} \right) \quad (dB)$$

Deutlichkeit (Early-late averaging OFF):

$$D = \frac{E_{0-50}}{E_{0-\infty}}$$

Deutlichkeit (Early-late averaging ON):

$$D = \frac{1}{3} \frac{E_{0-45} + E_{0-50} + E_{0-55}}{E_{0-\infty}}$$

Centre time:

$$T_s = \frac{\sum_0^{\infty} t E_t}{E_{0-\infty}} \quad (ms)$$

Sound Pressure Level:

$$SPL = 10 \log(E_{0-\infty}) \quad (dB)$$

The value of SPL becomes equal to the value of G (the total level re. to the level the source produces at 10 m in free field as defined in ISO 3382 [6]), when an OMNI directional source type and a power of 31 dB/Octave band is selected from within the appropriate Point Source Editor.

Lateral Energy Fraction (Early-late averaging OFF):

$$LF_{80} = \frac{\sum_{t=5}^{80} E_t \cos^2(\beta_t)}{E_{0-80}}$$

Lateral Energy Fraction (Early-late averaging ON):

$$LF_{80} = \frac{\sum_{t=5}^{72} E_t \cos^2(\beta_t) + \sum_{t=5}^{80} E_t \cos^2(\beta_t) + \sum_{t=5}^{88} E_t \cos^2(\beta_t)}{E_{0-72} + E_{0-80} + E_{0-88}}$$

It should be noted that the original definition of 'Lateral Energy Fraction' [6] assumes an ideal microphone having cosine directivity for energy. Real 'figure 8' microphones have cosine directivity for

pressure. In order that ODEON's predicted LF₈₀ values can be compared with measured results, ODEON uses the modified definition shown above, equivalent to cosine pressure sensitivity. The LF₈₀ parameter has a high correlation with the apparent source width (ASW) as shown in [29].

LG80* (Early-late averaging OFF):

$$LG_{80}^{\infty} = 10 \log \left[\frac{1}{4} \sum_{N_{125Hz}}^{N_{1000Hz}} \sum_{t=80}^{\infty} E_t \cos^2(\beta_t) \right] \quad (dB)$$

LG80* (Early-late averaging ON):

$$LG_{80}^{\infty} = 10 \log \left[\frac{1}{4} \sum_{N_{125Hz}}^{N_{1000Hz}} \left[\sum_{t=72}^{\infty} E_t \cos^2(\beta_t) + \sum_{t=80}^{\infty} E_t \cos^2(\beta_t) + \sum_{t=88}^{\infty} E_t \cos^2(\beta_t) \right] \right] \quad (dB)$$

The value of LG80* becomes equal to the value of Late lateral G (total late lateral level re. to the level the source produces at 10 m in the free field), when an OMNI directional source type and a power of 31 dB/Octave band is selected from within the appropriate Point Source Editor. This parameter is suggested in [29] and has a very high correlation with the subjective parameter Listener envelopment (LEV). Do note! In version 9.0 the summed energy is multiplied with 0.25 to be in accordance with the revised 3382 standard – therefore results of the LG parameter calculated in version 8 are 6 dB higher than the results from version 9.0.

Stage Parameters

Stage parameters are calculated as a part of the Single Point response (Auditorium and Combined versions only), if the job only contains one active source, the active source is a point source and the distance between receiver and source is approximately 1 metre (0.9 to 1.1 metre). The parameters are called Support for early, late and total energy and are described in more detail in [24]:

Early Support or ST1:

$$ST_{early} = \frac{E_{20-100}}{E_{0-10}} \quad (dB)$$

Late Support:

$$ST_{late} = \frac{E_{100-1000}}{E_{0-10}} \quad (dB)$$

Total Support:

$$ST_{total} = \frac{E_{20-1000}}{E_{0-10}} \quad (dB)$$

ST_{early} or ST₁ is used as a descriptor of ensemble conditions, i.e. the ease of hearing other members in an orchestra, ST_{late} describes the impression of reverberance and ST_{total} describes the support from the room to the musicians own instrument. If the early late averaging is turned ON, averaging in time is performed as for the other parameters. In case of the stage parameters the following limits of time intervals are used: 9 ms, 10 ms, 11 ms, 18 ms, 20 ms, 22 ms, 900 ms, 1000 ms and 1100 ms.

Warnings displayed with the room acoustical parameters

When the calculated reverberation curves appears very uneven, ODEON may come up with the following warning:

Warning: Direct sound not found, C, D, LF...may not be reliable.

When ODEON calculates the parameters including time intervals in the parameter definition e.g. the C₈₀ parameter, the origin of the time axis are set due to the closest source from where direct sound is

received. If no source is visible from the receiver or if a hidden source acts significantly earlier at the receiver, the time origin may come somewhat after the beginning of the actual reflectogram sequence. The warning may of course also indicate an erroneous position of the receiver.

STI - Speech Transmission Index

Speech Transmission Index, known as STI is calculated according to [7]. The STI parameter takes into account the background noise, which may be adjusted from the Room Setup. For the STI parameter to be valid, it is very important to adjust the background noise accordingly, remember that background noise must be set in a relative level if relative source gains are used. It should be mentioned that it is not stated in [7] what kind of directivity the source in the STI measuring system should have, so if using a source with directivity different from the one used in the real measurements in the simulations, results may not be comparable. The subjective scale of STI is given below:

Subjective scale	STI value
Bad	0.00 - 0.30
Poor	0.30 - 0.45
Fair	0.45 - 0.60
Good	0.60 - 0.75
Excellent	0.75 - 1.00

DL₂ - Rate of Spatial Decay

Rate of spatial decay is the decay of sound pressure level per distance doubling. DL₂ is calculated according to ISO 14257 [2]. The DL₂ parameter is intended to characterise the acoustic performance of workrooms. The values to be expected for the DL₂ parameter is according to [1]; 1 - 3 dB for reverberant rooms and 2 - 5 dB for ideally treated rooms. The design criterion for DL₂ is set to 3.5 dB or better according to ISO 11690-1 [3].

The DL₂ parameter is calculated as a part of the Multi Point response, if the job only contains one active source, the active source is a point source, more than one receiver is defined and the distance between the source and the receivers are not the same for all receivers. Please notice that one misplaced receiver may ruin the entire DL₂ calculation, thus it is a good idea to check the receiver positions or even better to check the individual results of the Multi Point calculation.

DL₂ is given for the frequency bands 63 Hz to 8 kHz and DL_{2,co.}, is the A-weighted Rate of Spatial Decay for the frequency bands 125 Hz to 4 kHz. For DL₂, as well as DL_{2,co} the correlation coefficients are calculated. If the correlation coefficients are low, this may indicate bad locations of source and or receivers, however it may also indicate a very low damping in the room (the Spatial Decay Curve being almost horizontal).

The measuring points (Receiver points) and the source position are of course essential to the DL₂ parameters and should follow ISO 14257 [2]. As an example a path of receivers may be chosen in the following distances from the source (using logarithmic increment):

1, 2, 4, 5, 6.3, 8, 10 metres

The positions should also follow the standard with respect to distance from floor and reflecting surfaces.

ODEON will use all the receivers defined in the receiver list. In some cases the positions of the receivers will not combine with the receiver positions that should be used for the receiver path in the DL₂ calculation. In this case the following solution is recommended:

- Make a copy of the room using the File|Copy files option, e.g. copy a room called MyRoom to MyRoomDL2Path and load the new copy when prompted for during the copy process.
- Delete receivers that are not wanted in the receiver path.
- Define the receivers needed.
- Finally make the Multi Point response calculation with the appropriate point source activated in the particular job.

8 Calculation Parameters - Room Setup and Define Grid

Most calculation parameters are by default set by ODEON, leaving you the choice of the essential parameters such as surface materials, surface scattering coefficients, source and receiver definitions. The only parameter that should always be specified by the user is the Impulse response length. If many surfaces are added to the room model in-between calculations, it is also recommended to re-specify the Number of Rays.

For most of the parameters on the Room Setup page ODEON suggest values that can be considered safe if there are no special demands and the room model does not contain decoupled rooms or very uneven distribution of the absorption area. When this is the case, it may be desirable to increase the Number of Rays (and uncheck Decimate late rays /increase the Desired reflection density).

In some cases it may also be desirable to change certain parameters in order to conduct special investigations or to speed up the calculations in preliminary studies of a room. In either case the parameters are described below.

Scattering method (Job calculations, Global Estimate and Quick Estimate)

If the Scattering Method is set to Lambert, all directions of 'late' reflections are calculated using the scattering coefficients assigned to the surfaces in the Materials List. E.g. if the scattering coefficient is 10 %, the new ray direction will be calculated as 90 % specular and 10 % scattered (random direction due to a Lambert distribution).

If the Scattering method is set to None, scattering is not taken into account, thus all reflections are calculated as specular and if it is set to Full scatter, 100 % scattering is applied to all surfaces. These settings are not recommended, except for initial tests, demonstration or research purposes.

Oblique Lambert

The Oblique Lambert method allows including frequency dependent scattering in late reflections of point response calculations - this option is recommended.

Reflection Based scatter

The Reflection based scattering method automatically takes into account scattering occurring due to geometrical properties such as surface size, path lengths and angle of incidence. The use of the method is recommended unless that part of scattering has already been included in the scattering coefficients assigned to the rooms' surfaces.

Interior margin

Typical geometrical offsets in the boundary of the room - default is 10 centimetres. Surfaces which are closer to the boundary surfaces of the room than the distance specified by the Interior margin will also be considered boundary surfaces - this means that surfaces such as doors or windows which may be modeled as being slightly on the inside of the boundary walls, will still be considered as boundary surfaces. Interior surfaces are displayed in a green colour (teal) in the 3DView whereas boundary surfaces are black so a change to the Interior margin will be reflected in this display when the Room Setup dialog is closed. The measure tells Odeon that effective scattering provided by boundary room surfaces should be restricted below a frequency derived from this measure -see the manual for details. To get an idea of our suggestions to this value please look into the geometries supplied with the installation of Odeon - whether a value of 10 or 20 centimetres is chosen may not be critical, but for rooms with a very 'jumpy' boundary it should be considered to specify this parameter.

Key diffraction frequency

Default is 707 Hz in order to obtain the best result in the mid frequency range for speech and music. This is the frequency at which diffraction is calculated for the ray-tracing part of calculations. All other parts of point response calculations take into account frequency dependent scattering. Only in special cases where the focus is on another frequency range, should this frequency be changed.

Scatter coefficients > s_{limit} to be handled uniformly

From published material on measured scattering coefficients, there seems to be a general tendency that modest scattering tends to be area based (indeed the Lambert law is used for light) whereas high scattering is better represented by uniform scatter. In Odeon small scattering coefficients below S_{limit} are handled either with the Lambert Oblique or Lambert algorithms whereas scattering coefficients above S_{limit} are handled using uniform scattering. Scattering coefficients in the context above are the Reflection Based Scattering coefficients (if that option is activated), a typical result of this algorithm is that reflections close to an edge will be handled with uniform scattering which is desirable. Through empirical studies we have found that $S_{\text{limit}} = 0.5$ yields best results. If using a value of 0 then all reflections are handled uniformly and if using a value of 1 then all reflections are handled using Lambert or Lambert Oblique as was the case in Odeon 8.0.

Decimate late rays (Job calculations only)

For surface and line sources the number of rays is simply decimated, for point sources the rays are decimated above the reflection order set by Transition order. In short terms fewer rays than Number of rays are traced for the late reverberant tail, but still a sufficient number to enable a good estimation of the reverberant behaviour. The reasons for doing this are to enable faster calculations to be carried out without compromising the resolution of early reflections, and to generate smaller ray history files. If you are using ODEON in a research context or if you have rooms with strong decoupling or uneven distribution of absorption area, you might wish to switch this setting off. Decimate late rays is by default on.

Number of Rays (Job calculations only)

The Number of rays to be used for the calculations is automatically set by ODEON; the number is specific for the room loaded and will usually be sufficient for reliable results. The number of rays specified is used for each source in a calculation.

To improve the reliability of the results, increase this number and switch off the Decimate Late Rays option. To decrease the calculation time used for job calculations decrease the number; this may be OK for rough "sketch" calculations.

Max. reflection order (Job calculations only)

Max. Reflection order is a stop criterion, which determines how many times a ray can be reflected. Under normal conditions it should be as big as possible; then the Impulse response length will be the actual stop criterion and Max. Reflection order is only taken into account when stopping rays that has been trapped between two very narrow surfaces. If the Max. reflection order is set to zero, then only direct sound is calculated.

Impulse response length (Job calculations and Global Estimate)

Determine how many milliseconds of the "decay curve" should be calculated. *This is an important parameter.* If it is shorter than approximately 2/3 of the reverberation time, T_{30} cannot be calculated because the dynamic range of the decay curve is less than 35 dB. For reliable results it is recommended to use an Impulse response length, which is comparable to the reverberation time.

Impulse response resolution (Job calculations and Global Estimate)

The Impulse response resolution is the width of the steps in the Impulse response histogram in which the energy of the reflections are collected during a point response calculation. The histogram is used for calculation of EDT and T_{30} . A resolution of approximately 10 ms is suggested.

Transition Order (Job calculations only)

The calculation methods used in Odeon 8 has been heavily updated, therefore recommendations given for the transition order, TO in earlier editions of Odeon does not apply anymore.

The transition order applies only to point sources. Below the transition order, calculations are carried out using the "Image Source Method" above TO a special ray-tracing algorithm is used (see section 6.4). Currently our 'safe' recommendation on the transition order is a transition order of 2 although it does not seem to be very critical anymore.

Transition order = 0

If a transition order of zero is selected then point responses will be calculated using ray tracing only. A TO of zero should be chosen for rooms with *many* fittings e.g. work rooms with many machines etc.

Transition order > 2

It seems that quality of results can be improved slightly for rooms such as fan shaped halls (with little diffusion) if using a TO as high as 5 or 6 - however not if only few rays are used in the calculation.

Smooth early late ratios (Job calculations only)

A smoothing procedure is normally applied when calculating C_{80} , D , ST_{early} , ST_{late} and ST_{total} and LF_{80} , to simulate the filtering in real measurements as well as the smearing that happens to real life reflections. The Smooth early/late ratios option is by default ON.

Smooth late decays (Job calculations only)

Causes a curve fitting and smoothing procedure to be applied to the reverberant decay, giving better appearance to the late part of the decays. The smoothing is a way of simulating that the number of reflections increases with respect to time, as it would in real rooms. The Smooth late decays option is OFF by default and doesn't improve the quality of results (except for the visual appearance of reverberation curves).

Desired late reflection density (Job calculations only)

Determines the reflection density, which ODEON will attempt to achieve in the late portion of the decay for Single and Multi Point Response calculations. The higher this value is, the smaller is the chance that unrealistic peaks will disturb the late part of the decay curve, using the default value of 100 /ms will usually be sufficient. To achieve the highest possible density; turn off the Decimate late rays option, use a high number of rays and a high Desired reflection density. You will find a separate value for the Desired late reflection density on the Define Grid page, which is used for the grid response calculations, as it is likely that you will want to speed up grid calculation.

9 Achieving good results

The following section discusses how to obtain good results and indeed what is a good result. It is not a straight answer as to how the best result is obtained, merely a discussion that may provide some ideas as to what can be done in order to obtain reliable results in a program such as ODEON.

The desirable precision - subjective limen

Before discussing how to achieve good results, it is a good idea to outline just what a good result is. The subjective limen (or just noticeable difference - *jnd*) on room acoustical parameters should give a good suggestion as to the desirable precision. If the error between the 'real' (measured with some precision) and the simulated room acoustical parameter is less than the one subjective limen, then there is no perceivable difference and the result is really as good as it can be, so it would be senseless to look for more precise results. In many cases it will be difficult or even impossible to obtain results at this precision and a poorer one will probably also be satisfactory for most purposes.

Parameter	Definition FDIS 3382-1 [6] (and CEI /IEC 60286-16 [7] for STI)	Subj. limen
T_{30} (s)	Reverberation time, derived from -5 to -35 dB of the decay curve	5 %
EDT (s)	Early decay time, derived from 0 to -10 dB of the decay curve	5 %
D_{50} (%)	Deutlichkeit (definition), early (0 - 50 ms) to total energy ratio	5 %
C_{80} (dB)	Clarity, early (0 - 80 ms) to late (80-∞) energy ratio	1 dB
T_s (ms)	Centre time, time of first moment of impulse response or gravity time	10 ms
G (dB)	Sound level related to omni-directional free field radiation at 10 m distance	1 dB
LF (%)	Early lateral (5 - 80 ms) energy ratio, $\cos^2(\text{lateral angle})$	5 %
STI (RASTI)	Speech Transmission Index	0.05

Room acoustical parameters and their subjective limen as given by Bork [39] and Bradley [40].

Example 1:

If the real G value is 1 dB and the simulated is 1.9 dB then the difference is not noticeable.

Example 2:

If the real LF value is 12 % and the simulated is 17 % the difference is just noticeable.

Note! When comparing measured parameters to the ones simulated it should be kept in mind that the measured parameters are not necessarily the true ones as there are also uncertainties on the measured results as well. These errors are due to limited tolerances in the measuring equipment as well as a limited precision in the algorithms used for deriving the parameters from the measured impulse response (or similar errors if results are not based on an impulse response measuring method). There may also be errors due to unprecise source and receiver positions.

9.1 Sources of error

There are many sources of errors in a room acoustical simulation, leading to results, which are less than perfect (within one subjective limen). Sometimes this is quite acceptable because we are just interested in rough results, at other times we are interested in results as good as possible. In any case being aware of the sources of error may help getting the maximum out of ODEON. The sources of error (or at least some of them) are:

- The approximations made in the ODEON calculation algorithms
- Inappropriate calculation parameters
- Material /absorption coefficients are imprecise
- Material /scattering coefficients are imprecise

- Geometry definition may not be accurate
- The measured reference data to which simulations are compared may not be accurate

9.1.1 Approximations made by ODEON

It should be kept in mind that algorithms used by a program such as ODEON are but only a raw representation of the real world. In particular, the effect of wave phenomena are only to a very little extent included in the calculations. There is very little to do with this fact for you the user, except to remember that small rooms and rooms with small surfaces are not simulated at high precision.

9.1.2 Optimum calculation parameters

A number of calculation parameters can be specified in ODEON. These settings may reflect reverberation time, a particular shape of the room or a trade-off between calculation speed and accuracy.

Decimate late rays

To use all the reflections found in the ray-tracing process; the Decimate late rays option should be switched off and the Late ray density should be set to its maximum.

Number of rays

ODEON by default specifies a suggested number of rays to be used in point response calculations. This number is derived taking into account the aspect ratio of the room as well as the number of surfaces in the geometry. In short this means that Odeon will suggest more rays for very long room with many surfaces, than for a basically cubic room with few surfaces. This suggested number of rays will be sufficient for many rooms, however in some cases more rays may be needed in order to obtain good results, in particular in rooms with:

- 1) Strong decoupling effects
- 2) Very uneven distribution of the absorption in the room

Ad 1)

If a dry room is coupled to a reverberant room, then more rays may be needed in order to estimate the coupling effect well. An example could be a foyer or a corridor coupled to a classroom. If the room where the receiver is located is only coupled to the room where the source is located through a small opening, then more rays are also needed.

Ad 2)

In some rooms the reverberant field in the x, y and z dimensions may be very different. An example of this could be a room where all absorption is located on the ceiling while all other surfaces are hard. Another example could be an open air theatre. In particular if surfaces are all orthogonal while having different materials in the x, y and z dimensions of the room and if low scattering properties on the surfaces are used, then more rays should be used.

More rays needed?

There are no way of telling if more rays are needed for a certain calculation, but to get an idea whether a room has strong decoupling effects, you may try to run the Global Estimate calculation. If:

- Global Estimate stabilizes slowly
- The Global decay curve make sudden jumps, like steps on a stair
- The Global decay show 'hanging curve' effect

This could be an indication that more rays are needed. Let the Global Estimate run until the decay curve seems stable, then use say 1/10 – 1 times the number of rays used in the Global estimate to specify the number of rays to be used in the calculation of the point responses (specified in the room setup).

Transition order

The 'Transition order' can be optimised taking into account the basic properties such as room shape into account, see section 8 for suggestions on Transition order.

9.1.3 Materials /absorption data

Wrong or imprecise absorption data are probably one of the most common sources of error in room acoustical simulations. This may be due to lack of precision in the measurements of the absorption data or because the material construction assumed in the simulations are really based on guesswork – in any case it is a good idea to remember this and to estimate the size of error on the material data as well as the impact on the simulated results.

Solution if materials data are uncertain:

There is really not much to do about the uncertainty of material data if the room does not exist except taking the uncertainty of the materials into account in the design phase. If the room does indeed exist and is being modeled in order to evaluate different possible changes it may be a good idea to tweak (adjust) such uncertain materials until the simulated room acoustical parameters fits the measured ones as good as possible.

Absorption properties in a material library are often, by users, assumed to be without errors. This is far from being the truth. For high absorption coefficients and high frequencies the values are probably quite reliable however; low frequency absorption data and absorption data for hard materials will often have a lack of precision.

Low frequency absorption

At low frequencies the absorption coefficients measured in a reverberation chamber are with limited precision because:

- There are very few modes available in a reverberation chamber at lowest frequency bands.
- Low frequency absorption occurs partly due to the construction itself rather than its visible surface structure. Often it may not be possible to reconstruct a complete building construction is a reverberation chamber and if reconstructing only a fraction of the wall in the reverberation chamber it will have different absorption properties, because it becomes less or more stiff.

There is no current solution to these problem, but one can hope that new measuring techniques will to some extent overcome the problems.

Hard materials

Hard materials such as concrete are often listed as being 1 % or 2 % absorbing. It may sound like a difference of 0.5 % or 1 % is not a significant difference. However if a room is dominated by this material (or if one of the dimensions of the room is) a change from 1 to 2 % is a relative change of 100 %.

9.1.4 Materials /scattering coefficients

The knowledge on scattering coefficients is currently rather limited. Hopefully in the future, the scattering coefficients will be available for some materials. Meanwhile the best that can be done is to make some good guesses on the size of the scattering coefficients and to do some estimates on the effect of uncertainty.

9.1.5 Measurements

Eventually the reference data, which you may compare with simulated room acoustical parameters are not perfect. We must accept some tolerances on the precision of the measured parameters.

9.1.6 Receiver position(s)

Common errors are:

- to base the room acoustic design on simulations in one or only few receiver positions
- to place the receiver close to a surface.
- to use too short source-receiver distance

9.1.7 Source-Receiver distance

Point response calculations made in ODEON are to be compared with point response measurements and as such the ISO 3382 standard should be followed:

To obtain good estimates of reverberation time, the minimum source-receiver distance should be used in order to avoid strong influence from the direct sound. The minimum source–receiver distance according to ISO 3382 is:

$$d_{\min} = 2\sqrt{\frac{V}{c*T}}$$

where :

- V is the volume of the room in cubic metres
- c is the speed of sound, in metres per second
- T is an estimate of the expected reverberation time, in seconds

Thus for a typical concert hall a source-receiver distance less than 10 metres should be avoided in order to get good predictions (measurements) of the reverberation time.

9.1.8 Minimum distance from the receiver to the closest surface

If a receiver is placed very close to a surface then results will be sensitive to the actual position of the secondary sources generated by ODEON. If such a secondary source happens to be very close to the receiver e.g. 1 to 10 centimetres this may produce a spurious spike on the decay curve, resulting in unreliable predictions of the reverberation time – indeed if the distance is zero then in principle a contribution being infinitely large would be generated. To avoid this problem it is recommended that distances to surfaces are kept greater than say 0.3 to 0.5 metres. Anyway for measurements it is, for other reasons, recommended to keep distances greater than a quarter of a wavelength, i.e. 1.3 metres at 63 Hz – a distance of 1 metre is required by ISO 3382.

10 Directivity patterns for point sources

Common loudspeaker format, CL1 and CF2 files

Odeon 8 and later supports the Common Loudspeaker Format which is an open format for loudspeaker data, supported by several loudspeaker manufacturers as well as manufactures of software programs such as Odeon. The *Common Loudspeaker Format* was developed and is maintained by the *CLF-group* at www.clfgroup.org. It is an open, though secure, file format for loudspeaker performance data and polar plots which loudspeaker manufacturers can use to supply data to end users in the professional sound and acoustics community.

CLF is defined in two parts, a text-based format used solely for data input and editing, and a binary format for data distribution – as a user of ODEON you should deal only with the *binary distribution files* having the extensions *CL1* and *CL2*. In order to view all data in the CLF format you should download a free viewer from the CLF home page.

The CLF Group is providing a set of free tools for data editing, conversion from text to binary format and viewing binary data allowing loudspeaker manufacturers to create, view and verify binary distribution files for use in programs such as Odeon. This ensures that it is easy for loudspeaker manufactures to make these data available. Links to loudspeaker manufacturers currently providing *binary distribution files* can be found at the download page at www.clfgroup.org. If apparently the data of interest is not available from the manufacturer of interest, then assist the Clf-group by encouraging the manufacturer to make such data available – free tools for this purpose can be obtained at www.clfgroup.org.

10.1 File location for directivity files

No matter if files are in the CL1, CL2 or in Odeon's native So8 format, the files should be stored in Odeon directivity directory which is specified inside Odeon at Options|Program setup|Directivity files location. The files may be stored in subdirectories to this directory allowing loudspeaker directivities of different brands to be located in separate directories e.g. C:\odeon\DirFile\ManufacturerA or C:\odeon\DirFile\ManufacturerB. We have taken the opportunity to create a number of folders for manufactures which do supply loudspeaker directivity files in the CLF format. Using these predefined directories, it is easier to move a room from one PC to another without breaking file linkage.

10.2 Creating new directivity patterns in the Odeon .So8 format

Tools for creating directivity patterns in the Odeon .So8 format can be found at the Tools|Creating directivity patterns menu entry inside the ODEON program. The tools allow you to expand the set of source directivity pattern files available for point sources in ODEON. The ODEON directivity pattern file (Version 3 or later) contains information on the sound levels for the eight frequency bands 63 Hz to 8 kHz in dB for each 10° azimuth and 10° elevation. These files are binary and have the extension .SO8. An example on a directivity pattern is the pattern stored in OMNI.SO8.

10.3 Entering a directivity plot using the Directivity plot editor

The easiest way to enter a new directivity plot is to use the built-in plot editor which allows building a directivity plot from a vertical and a horizontal plot.

Enter the dB values for the horizontal and vertical plots at the selected frequency band in the corresponding tables. The angular resolution is 10° degrees. If data are not entered for all angles e.g. if the data are not available, Odeon will do interpolation between the angles entered. For angles between the polar plots, Odeon will perform elliptical interpolation.

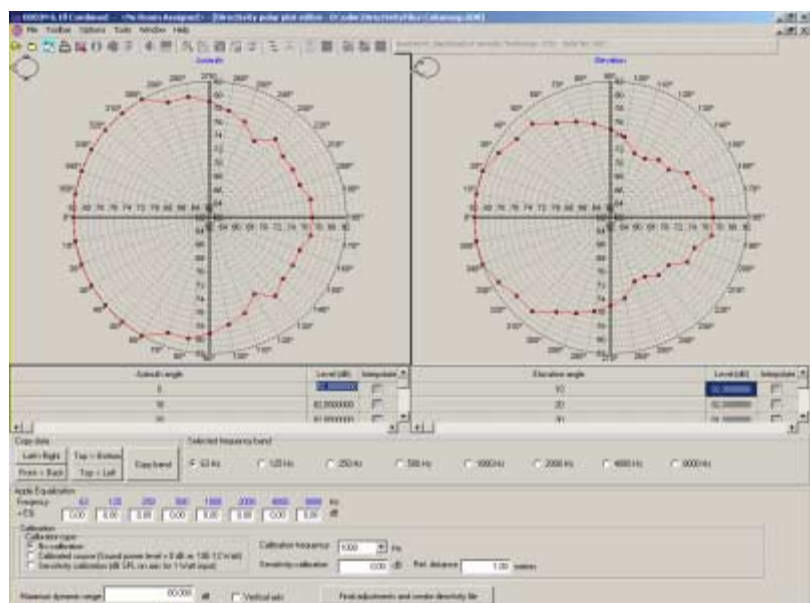

Calibration

Three different options are available:

- If No calibration is selected, Odeon will use the dB values as entered in the table, adding the equalization values entered.
- If Calibrated source is selected Odeon will add the equalization entered, then shift the resulting SPL's of the source in order to obtain a sound power level of 0 dB re. 10E-12 Watt at the selected Calibration frequency band. This calibration type is typically used for generic source types such as the OMNI or SEMI directivity pattern.
- If Sensitivity calibration is selected the SPL's of the source will be shifted in order to obtain the SPL is Sensitivity calibration dB on axis of the source at the distance specified as Ref. distance metres.

Maximum dynamic range

The 'minimum level' will be 'Max level' minus 'Maximum dynamic range'. If the range is large the display may not be optimum in the directivity viewer. The source will usually have its max level at its polar axis.

10.4 Creating a new directivity pattern using a text file as input

Another way to create new patterns is to enter the data describing the directivity pattern into an text input file. Depending on the data available and the complexity of the source one of three different text formats may be used. Once the text input file has been created in one of the formats specified below (e.g. in the Odeon editor; OdwEdit), it can be translated into an ODEON Directivity file, which can be applied to any point source from within ODEON.

To translate the created text file into an ODEON directivity file:

- Select Tools>Create directivity (.So8) from ASCII file (.DAT)
- Open the input file you have created.
- Specify the name of the directivity file pattern you wish to create.
- Select whether you wish a Calibrated source or not.
- Apply calibration data as prompted for.

Applying Calibration

Creating a new directivity file you will be prompted whether to create a calibrated source or not:

Calibrated source (Sound Power Level = 0 dB re 10E-12 W at 1 kHz) ? [YES/NO]

Calibrated Sources

Press [YES] if an absolute level is not relevant to the directivity pattern; an example on this could be the OMNI or SEMI directional directivity pattern. When selecting a calibrated source, no data apart from the ASCII input file are required. The directivity represented by this file is preserved, but the values are simply shifted by a constant amount (the same for all bands), such that the sound power level of the source is 0 dB re. 10-12 Watts at 1 kHz. Please do note that the power in the other bands may differ from 0 dB. You may still alter the overall power response of the source by applying an EQ, however the power at 1 kHz will always end up as 0 dB, the other bands shifted accordingly.

NON-calibrated sources - Electro acoustical sources, machinery, natural sources etc.

Press [NO] to preserve the sensitivity of an electro acoustical source or the absolute level of natural source, e.g. a human voice. When selecting the NON-CALIBRATED source you are allowed to enter equalising, electric losses (zero for natural sources) and a sensitivity at a selected frequency band (zero for natural sources).

The addition of electrical sensitivity, electrical input power and electrical loss values completes the data necessary to generate a source directivity file directly readable by ODEON 3 or later.

The DirectivityFilesUtility program can perfectly well be used to generate a .SO8 file for an electro-acoustic source. Various approaches may be used. In the simplest case, the ASCII input file should contain relative SPL values as for an electro acoustic source. The sensitivity should be given as the true SPL obtained for the calibration band (e.g. 1 kHz) at a 1-metre distance (transformed to that distance if necessary using the 6 dB per doubling of distance rule). The EQ values should all be zero. Such a .SO8 file can be used without further Gain or EQ settings in ODEON. In certain cases, the form of the available data or the mode of usage may make this approach inappropriate. Sensitivity and EQ within DirectivityFileUtility.exe, and Gain and EQ within ODEON may be combined in many ways to achieve the desired result.

Text format

The data presented to the Odeon should be in relative calibration across frequency, but need not be in any absolute calibration (this calibration is applied from within the program). Thus the data for the forward on-axis direction constitutes a relative frequency response for that direction, which is used to calculate the frequency-dependency of the source's on-axis sensitivity.

The first non-comment line of the input file indicates whether the data is for:

- FULL set, for complex sources where directivity data is known for each 10° Azimuth and 10° Elevation.
- SYMMETRIC set, for symmetric sources, e.g. a trumpet.
- POLAR set containing only horizontal and vertical polar plots, for sources where only a horizontal and a vertical plot are known, e.g. a loudspeaker.

Each of the subsequent lines of the input file should contain sound levels in dB for a complete 180° of elevation (from the forward axis to the backward axis). The resolution must be 10°, hence each line contains 19 values (0°, 10°, 20°.....160°, 170° and 180°). Comment lines are allowed anywhere in the ASCII input file(s).

When only horizontal and vertical polar plots are known (POLAR)

The first non-comment line of the file should start with the word POLAR. In the polar case, there are four lines of data for each frequency band. The first four lines are for 63 Hz, the next four for 125 Hz, and so on.

For a given frequency, the first and last values must agree on all four lines, since all the polar plots meet at the polar axis. The first line of a group of four is the upward vertical polar plot as seen from in front of the source (12 o'clock plot). Then come the left horizontal plot (9 o'clock plot), downward vertical plot (6 o'clock plot) and finally the right horizontal plot (3 o'clock plot).

As a minimum there must be $1 + 4 * 8$ lines in a polar input file.

Elliptical interpolation

When the DirectivityFileUtility translates the polar input file it has to interpolate values between the four polar planes given in the input data. This is done using elliptical interpolation independently for each frequency band, creating the 8 x 4 plots missing between the four input plots.

An example; Polar_Omni.dat on the polar input format can be found in the DirFiles directory, created at the installation of ODEON.

When the complete directivity characteristics are known (FULL)

The first non-comment line of the file should start with the word FULL. In the full case, there are 36 lines of data for each frequency. The first 36 lines are for 63 Hz, the next 36 lines for 125 Hz, and so on.

As a minimum there must be $1 + 36 * 8$ lines in a full input file.

- 1. line is vertical upper plot 0° (12 o'clock plot, when looking at the source, e.g. at a loudspeaker membrane)
- 10. line is horizontal left plot 90° (9 o'clock plot)
- 19 line is lower vertical plot 180° (6 o'clock plot)
- 28. line is right horizontal plot 270° (3 o'clock plot)

An example; Full_Omni.dat on the full input format can be found in the DirFiles directory, created at the installation of ODEON.

When the directivity pattern is rotationally symmetric

The first non-comment line of the file should start with the word SYMMETRIC. In the SYMMETRIC case, there is one line of data for each frequency.

As a minimum there must be $1 + 8$ lines in a symmetric input file.

Examples of SYMMETRIC sources are a Trumpet and the Omni directional source.

An example; Symmetric_Omni.dat on the SYMMETRIC input format can be found in the DirFiles directory, created at the installation of ODEON.

Samples on directivity patterns (TLKNORM, TLKRAISE and Soprano ref. 42)

The TLKNORM source type corresponds to a male talker with a normal vocal effort. The gain and EQ fields in the Point source editor (inside ODEON) should be set to zero. This source is also a reasonable approximation to a female talker, except that the 63 and 125 Hz band should be ignored.

To simulate a trained talker addressing an audience in a raised voice, use the TLKRAISE source. This has the same directivity as TLKNORM, but the levels in the eight octave bands are respectively 2, 2, 5, 7, 9, 8, 6 and 6 dB higher. The directivity pattern of Soprano ref. 42 is the directivity of a soprano singing opera [42].

Comments and empty lines

Lines containing comments, and empty lines, may be inserted anywhere in the file, as long as they do not come between data items, which should occur on one line. Comment lines must begin with a colon (:), an semicolon (;) or an asterisk (*).

10.5 Compatibility with previous versions of ODEON

The directivity files of ODEON 2.6D and earlier (having the file extension .SOU) is based on the six octave bands (125 to 4000 Hz), where ODEON version 3 or later is using the eight octave bands (63 to 8000 Hz). Thus, new files have to be created containing the information for the eight bands. The levels for 63 and 125 Hz will be equal (just copied) and the levels for 4 and 8 KHz will be equal (just copied).

To create a directivity pattern for ODEON 3 or later (e.g. OMNI.SO8) from an ODEON 2.6D directivity file (or earlier):

- Select File|Translate 6 band into 8 bands.
- Open the old directivity file (e.g. OMNI.SOU)

The new directivity pattern file OMNI.SO8 will automatically be saved at the default path for directivity pattern files (e.g. C:\ODW6_0\Dirfiles). This path is specified from within the ODEON program (at the toolbar dropdown menu: Options|Program setup).

9.3 Making a readable text file from a directivity pattern file (.SO8)

To read the contents of a directivity file:

- Select File|Create ASCII file from .SO8 file.
- Open the .SOU file you wish to read.
- Open the newly created ASCII file (e.g. C:\ODW\DirFiles\Omni.Asc) using a text editor like NOTEPAD.

This may be useful for instance to see how the interpolation of the polar plots worked out.

The generated ASCII output file will use the separating character specified from within the ODEON program (OdwCombined.Exe, OdwAuditorium.Exe or OdwIndustrial.Exe) from the dropdown menu at Options|Program setup|ASCII output. The character will be inserted between each value in the output file. The default separator is a single space.

The file generated is an ASCII file containing the values in SPL at 1 metre defined in the input file. The format of the file is the same as that of an input file of the FULL type.

Appendix A: Mathematical expressions available in the .Par modeling format

Constants, variables, point numbers, surface numbers and coordinates may be defined using mathematical expressions. Where integer numbers are expected (Counter ranges in for..end loops, point, surface numbers, etc.), the results of mathematical expressions are automatically rounded to the nearest whole number.

Operation	Syntax	Example
Addition	+	$2 + 5 = 7$
Subtraction	-	$3 - 1 = 2$
Multiplication	*	$2 * 3 = 8$
Division	/	$4 / 2 = 2$
Power	Base^ Exponent or Power(Exponent,Base)	$2^3 = 8$ or $Power(3,2) = 8$
Root	Root(Y,X)	$Root(3,8) = 2$
Round	Round(X)	$Round(2.67676) = 3$
Truncation	Trunc(X) or Int(X)	$Trunc(1.7) = 1$
Sine of an angle in radians	Sin(X)	$Sin(0) = 0$
Cosinus of an angle in radians	Cos(radians)	$Cos(PI/4) = 0,707106781186547573$
Tangens of an angle in radians	Tan(radians)	$Tan(PI/4) = 1$
Cotangens of an angle in radians	Cotan(radians)	$Cotan(180) = 0$
Hyperbolic Sine to angle in radians	Sinh(radians)	$Sinh(0) = 0$
Hyperbolic Cosine to angle in radians	Cosh(radians)	$Cosh(0) = 1$
Sine to angle in degrees	SinD(radians)	$SinD(90) = 1$
Cosine to angle in degrees	CosD(degrees)	$CosD(0) = 1$
Tangens of an angle in degrees	TanD(degrees)	$TanD(45) = 1$
Cotangens of an angle in degrees	CotanD(degrees)	$CotanD(90) = 0$
Inverse Sine in radians	ArcSin(Y)	$ArcSin(-Sqrt(2)/2) * 180/PI = -45$
Inverse Cosine in radians	ArcCos(X)	$ArcCos(Sqrt(2)/2) * 180/PI = 45$
Inverse Tangens in radians	ArcTan(Y)	$ArcTan(1) * 180/PI = 45$
Inverse Tangens II in radians	ArcTan2(X,Y)	$ArcTan2D(1,-1) * 180/PI = -45$
Inverse Sine in degrees	ArcSinD(Y)	$ArcSin(-Sqrt(2)/2) * 180/PI = -45$
Inverse Cosine in degrees	ArcCosD(X)	$ArcCos(Sqrt(2)/2) * 180/PI = 45$
Inverse Tangens in degrees	ArcTanD(Y)	$ArcTan(1) = 45$
Inverse Tangens II in degrees	ArcTan2D(X,Y)	$ArcTan2D(1,-1) = -45$
Exponential	Exp(X)	$Exp(1) = 2.71828182845904509$
Natural Logarithm	Ln(X)	$Ln(2.718281828459045091) = 1$
Logarithm base 10	Log10(X)	$Log10(100) = 2$
Logarithm base 2	Log2(X)	$Log2(8) = 3$
Square	Sqr(X)	$Sqr(2) = 4$
Square root	Sqrt(X)	$Sqrt(2) = 1.41421356237309515$
Radius	Radius(A,B)	$Radius(3,4) = 5$
Absolute value	Abs(X)	$Abs(-2342) = 2342$
Sign	Sign(X)	$Sign(-2) = -1; Sign(0) = 0; Sign(3) = 1$
Minimum number of two members	Min(X,Y)	$Min(23,12) = 12$
Maximum of two numbers	Max(X,Y)	$Max(23,22) = 23$

Appendix B: References

- [1] Ondet A.M. and Sueur, J., Development and validation of a criterion for assessing the acoustic performance of industrial rooms, *J. Acoust. Soc. Am.* 97 (3), March 1995 p 1727 - 1731.
- [2] ISO 14257, *Acoustics - Measurement and modeling of spatial sound distribution curves in workrooms for evaluation of their acoustical performance.*
- [3] ISO 11690-1, *Acoustics:1996 - Recommended practice for design of low-noise workplaces containing machinery - Part 1: Noise control strategies.*
- [4] ISO 11690-2:1996, *Acoustics - Recommended practice for design of low-noise workplaces containing machinery - Part 2: Noise control measures.*
- [5] ISO/TR 11690-3: 1997, *Acoustics - Recommended practice for design of low-noise workplaces containing machinery - Part 3: Sound propagation and noise predictions in workrooms.*
- [6] ISO /DIS 3382-1: *Acoustics - Measurement of the reverberation time - Part 1: Performance rooms.*
- [7] CEI/IEC publication 60268-16 first edition:1998. *Sound system equipment, part 16: Objective rating of speech intelligibility by speech transmission index.*
- [8] G.M. Naylor & J.H. Rindel, *Odeon Room Acoustics Program, Version 2.5, User Manual.* Publication No. 49, The Acoustics Laboratory, Technical University of Denmark, Lyngby, 1994. (103 pages).
- [9] J.H. Rindel, *Computer Simulation Techniques for Acoustical Design of Rooms.* *Acoustics Australia* 1995, Vol. 23 p. 81- 86.
- [10] J.H. Rindel, *Computer simulation techniques for the acoustical design of rooms - how to treat reflections in sound field simulation.* *ASVA 97, Tokyo, 2- 4 April 1997.* Proceedings p. 201-208.
- [11] Cremer, L. and H. Müller, *'Principles and Applications of Room Acoustics'*, Applied Science Publishers, London, 1982.
- [12] Barron, M. and A.H. Marshall, "Spatial Impression Due to Early Lateral Reflections in Concert Halls: The Derivation of a Physical Measure", *Journal of Sound and Vib.*, 77, pp 211-232, 1981.
- [13] Kristensen, J., "Sound Absorption Coefficients - Measurement, evaluation, application", Note no. 45, *Statens Byggeforskningsinstitut, Hørsholm, 1984 (in Danish).*
- [14] Knudsen, V.O. and C.M. Harris, *'Acoustical Designing in Architecture'*, John Wiley, 1953.
- [15] Bobran, H.W., *'Handbuch der Bauphysik'*, Verlag Ulstein, Berlin, 1973.
- [16] Ingerslev, F, *Lærebog i bygningsakustik for Ingeniører'*, Teknisk forlag, Copenhagen, 1949.
- [17] Petersen, J., *'Rumakustik'*, SBI-anvisning 137. *Statens Byggeforskningsinstitut, Hørsholm, 1983.*
- [18] Parkin, P.H., H.R. Humphreys and J.R. Cowell, *'Acoustics, Noise and Buildings'*, Faber and Faber, London, 1979.
- [19] Fasold, W. and H. Winkler, *'Bauphysikalische Entwurfslehre, Band 4: Bauakustik'*, VEB Verlag für Bauwesen, Berlin, 1976.
- [20] Meyer, E., D. Kunstmann and H. Kuttruff, *Über einige Messungen zur Schallabsorption von Publikum'*, *Acustica* 14, 119-124, 1964.
- [21] Beranek, L.L., *'Music, Acoustics and Architecture'*, John Wiley, 1962.

- [22] Ingerslev, F. and J. Petersen, 'Lydabsorberende Materialer', Arkitektens Ugehefteno. 3, 1953.
- [23] Dührkop, H. et al, 'Mørtel, muring, pudsning. Teknologisk håndbog', SBI anvisning 64, 2nd edition, Statens Byggeforskningsinstitut, Hrsholm, 1981.
- [24] Gade, A.C., Rumakustisk måleteknik, særtryk 14 til kursus 5142. Department of Acoustic Technology, Technical University of Denmark, Lyngby, 1990.
- [25] Gade, A.C., 'Practical Aspects of Room Acoustic Measurements on Orchestra Platforms', ICA 14 Proceedings Vol. 3, paper F3-5, Beijing 1992.
- [26] Beranek, Leo, How they sound, Concert and Opera Halls. Acoust. Soc. of Am. 1996.
- [27] Barron Michael, Auditorium Acoustics and Architectural Design. E& FN Spon, and imprint of Chapman & Hall, 2 - 6 Boundary Row, London SE18HN, UK 1993.
- [28] Gade, A.C., The Influence of basic design variables on the acoustics of concert halls; new results derived from analysing a large number of existing halls. Proceedings IOA. Vol 19 Part 3 (1997).
- [29] Bradley John S., Gilbert A Soulodre. Objective measures of listener envelopment. J. Acoust. Soc. Am. 98 (5), 1995 p 2590 - 2595.
- [30] Leo L. Beranek, Takayuki Hidaka. Sound absorption in concert halls by seats, occupied and unoccupied, and by the hall's interior surfaces, J. Acoust. Soc. Am. 104. December 1998 p 3169-3177.
- [31] Rindel, J.H, Modeling the Angel-Dependent Pressure Reflection Factor. Applied Acoustics, 38 p 223 - 234.
- [32] Bill Gardner and Keith Martin. MIT Media Lab., HRTF Measurements of a KEMAR Dummy-Head Microphone, <http://sound.media.mit.edu/KEMAR.html>.
- [33] William H. Press Brian P. Flannery, Saul A. Teukolsky, William T. Vetterling, Numerical recipes in Pascal, The Art of Scientific Computing, Cambridge University Press 1990.
- [34] Affronides, Sophocles, Introduction to Signal processing, J.Prentice Hall International, 1996.
- [35] Oppenheim, Alan V. Schafer, Ronald W., Discrete-Time Signal Processing. Prentice Hall International 1989.
- [36] Music for Archimedes, CD B&O 101, 1992.
- [37] Anechoic Orchestral Music Recordings, Denon PG-6006, 1988.
- [38] Ming Zang, Kah-Chye Tan, M. H. Er, Three-Dimensional Sound Synthesis Based on Head-Related Transfer Functions. Centre for signal processing, School of Electrical and Electronic Engineering, Nanyang Technological University, Singapore 639798
- [39] Bork, Ingolf. A Comparison of Room Simulation Software – The 2nd Round Robin on Room Acoustical Computer Simulation, Acta Acoustica, Vol. 86 (2000), p. 943-956.
- [40] Bradley J. S., Predictors of speech intelligibility in rooms, J. Acoust. Soc. Am., Vol 80, No. 3, pp 837-845 (1986).
- [41] The CIPIC HRTF Database <http://interface.cipic.ucdavis.edu/>
- [42] Linda Parati, Filipe Ortondo, Comparison of Directional Sources in Simulating a Soprano Voice. Proceedings of the Stockholm Music Acoustics Conference, August 6-9, 2003 (SMAC 03), Stockholm, Sweden.

- [43] M.A. Gerzon, General Metatheory of Auditory Localisation, Preprint 3306 of the 92nd Audio Engineering Society Convention, Vienna March 1992.
- [44] Bamford, Jefery Stephen. An Analysis of Ambisonics Sound Systems of First and Second Order. A thesis presented to the University of Waterloo in fulfilment of the thesis requirement for the degree of Master of Science in Physics. Waterloo, Ontario, 'Canada, 1995.
<http://audiolab.uwaterloo.ca/~jeffb/thesis/thesis.html>
- [45] Dave Malham, Home page for Ambisonics and related 3-D audio research, Music Technology Group, The University of York. http://www.york.ac.uk/inst/mustech/3d_audio/
- [46] Richard Furse, 3D Audio Links and Information, <http://www.muse.demon.co.uk/3daudio.html>
- [47] Ingolf Bork, Report on the 3rd Round Robin on Room Acoustical Computer Simulation – Part II: Calculations, Acta Acoustica United with Acoustica, Vol. 91 (2005), p. 753 - 763.
- [48] M.R. Schroeder. Digital Simulation of Sound Transmission in Reverberant Spaces. JASA 47, 424-431, 1970.
- [49] DIRAC. <http://www.acoustics-engineering.com/dirac/dirac.htm>
- [50] Insul, Marshall Day Acoustics <http://www.insul.co.nz/>

Appendix C, Vocabulary

The techniques of auralization make use of many of technologies and a lot of technical terms and abbreviates are commonly used in the literature. Here is a short vocabulary to some of the most used expressions - the vocabulary is not a complete description of the individual words - the context under which the words are used are many and the subjects are rather complex.

Anechoic recording

Anechoic recordings are recordings of sound sources made without any reflections from the surroundings contributing to the recordings. A common problem with anechoic recordings are that they may often include too many high frequency components, because they are usually near field recordings and because they are recorded 'on axis' where these components usually dominate. When using such recordings with auralization systems this may often result in unrealistic sharp 's'-sounds especially in case of long reverberation times. Anechoic recordings are usually recorded in an anechoic room, but semi anechoic recordings may also be acceptable for use with auralization systems, this could be outdoor recordings of machinery, trains etc. or studio recordings of music.

Auralization, auralisation

The term auralization was invented by Mendel Kleiner who gives the following definition: Auralization is the process of rendering audible, by physical or mathematical modeling, the sound field of a source in a space, in such a way as to simulate the binaural listening experience at a given position in the modeled space.

In the way auralization is used in ODEON, one may think of auralization as the art of creating digital simulations of binaural recordings in rooms (which may not be build yet). The aim is to provide the same three-dimensional listening experience to the listener as would be achieved in the real room at the given receiver position with the simulated source position(s) and signals.

HRTF's - Head Related Transfer Functions

In short terms the HRTF describes how an impulse arriving at a person /dummy head is smeared out by diffraction phenomenon's from head and torso of the 'person'. While an incoming impulse is only 1 (sample) long, this will result in an impulse response arriving at the right and an impulse response arriving at the left ear, which may typically have a length (of interest) of some 2 -3 milliseconds (approximately 100 samples at a 44100 Hz sample rate or if you prefer a length of 1 metre or so) - this is what is described by the HRTF's. A set of HRTF's used for auralization will typically contain a library for many different angles of incidence. The HRTF's that comes with ODEON are those made available by Bill Gardner and Keith Martin at MIT Media Lab. at <http://sound.media.mit.edu/KEMAR.html> as well as those from the CIPIC Interface Laboratory at <http://interface.cipic.ucdavis.edu/index.htm>. If you have the capability of measuring HRTF's it is possible to import new sets for use with ODEON.

Binaural (recording)

Humans (usually) listens using two ears. This allows us to perceive sound as a 3D phenomenon. To create a binaural recording, its not enough to create a two-channel recording (stereo), also the colouration created by diffraction from the human body has to be included. This is usually done by using a dummy head with a microphone mounted at the entrance of each ear canal - this recording may be recorded using an ordinary stereo recorder - but is now refereed to as binaural. Binaural recordings are usually played back through headphones to avoid colouration from the room in which it is played as well as avoiding diffraction from the human body to be included twice (at the recording and at the playback). If one has measured or indeed simulated the BRIR's (see below) in a room, it is possible to 'simulate' a binaural recording.

BRIR - Binaural Room Impulse Response

The BRIR is the key to binaural room acoustic auralization. The BRIR is a set of impulse responses detected at the left and right entrance of the ear canals of a dummy head (or indeed at blocked entrenches of the ear channels of a (living) person residing in a room, when a sound source (or some sound sources) has emitted an impulse. The BRIR should include all the (necessary) information on receiver position and orientations, source(s) position(s) and orientations, room geometry, surface materials and the listener's geometry (described by the HRTFs). Convolution of the left channel of the BRIR and the right channel of the BRIR with a mono signal, a binaural signal is created, which when presented to the listener over headphones gives the impression of the three dimensional acoustics at a

particular position in the room. It is also possible to simulate the recording of the BRIR's, which is what ODEON does.

Appendix D Specify Transmission through walls

A new feature in Odeon 9 is the ability to handle transmission through walls taking into account multiple transmission paths, allowing walls to have a thickness and to have different materials on either side of the transmission wall.

Assigning transmission data

Once a Type of a wall has been set to Transmission in the MaterialList, it becomes possible to specify transmission data, using the Edit transmission data for surface option (shortcut Alt+Y). This opens a dialog where Reduction indexes can be specified in one-third octave bands from 50 Hz to 10 kHz. The data can be entered directly or copied from a spreadsheet (or from a text file) using the common shortcuts Ctrl+C and Ctrl+V see description below.

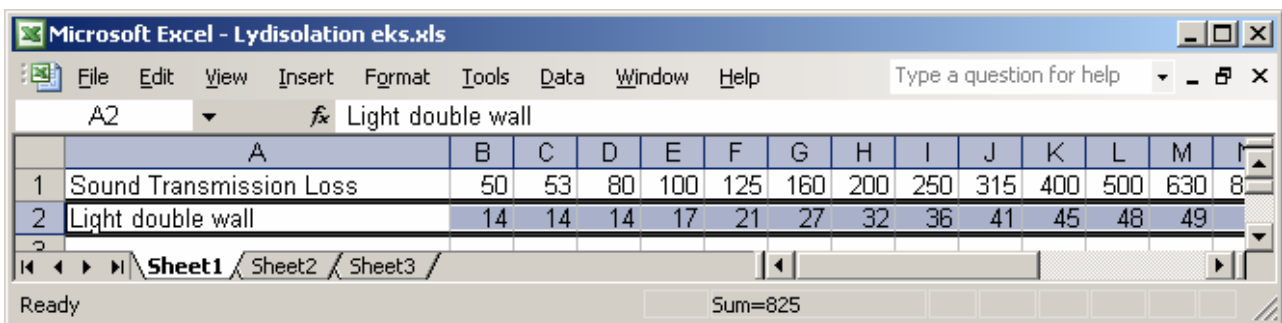

	A	B	C	D	E	F	G	H	I	J	K	L	M	N
1	Sound Transmission Loss	50	53	80	100	125	160	200	250	315	400	500	630	8
2	Light double wall	14	14	14	17	21	27	32	36	41	45	48	49	

Figur D1 Copying a material from MsExcel: A material to be copied may contain a leading comment /name and must end by 24 floating point values denoting the 24 reduction indexes from 50 Hz to 10000 Hz (the first value is always assumed to be for the 50 Hertz one-third octave band, if the number of bands is less than 24 then the last value is used for the bands above, if more than 24 values, the values above 10 kHz are discarded). To copy the values from MsExcel, mark the relevant cells and press Ctrl+C - to paste the values into Transmission dialog, simply press Ctrl+V. Likewise to copy data from the *Transmission* dialog to MsExcel press Ctrl+C while the dialog is the selected window in Odeon - then select the first cell in MsExcel (or which ever cell is relevant) and press Ctrl+V. Data can also be imported from Insul Sound Insulation Prediction software [50], simply by Copy the spectrum for Bastian format and paste into ODEON.

Single or double sided walls

Sometimes a transmission wall may be composed by two individual surfaces (two separate surfaces in the MaterialsList) as shown in the illustration from the 3DBilliard display below. It is possible for Odeon to link together such a pair of surfaces if they are (almost) parallel, allowing transmission trough walls with a thickness and with different absorption properties on either side. To accomplish this, it is important that:

- Transmission type is assigned to both surfaces in the MaterialsList.
- Same set of reduction indexes are selected on either surface in the Transmission dialog.
- Double sided wall check mark is selected for both surfaces in the Transmission dialog.

Most of the above can usually be accomplished if the *Update double sided wall upon exit* is checked when Transmission data for the first wall is edited. It is recommended checking and rechecking the data entered for transmission data before making calculations, a check may involve using the 3DBilliard or 3D Investigate Rays to ensure that walls do in fact transmit sound and that double sided walls has been set up correctly.

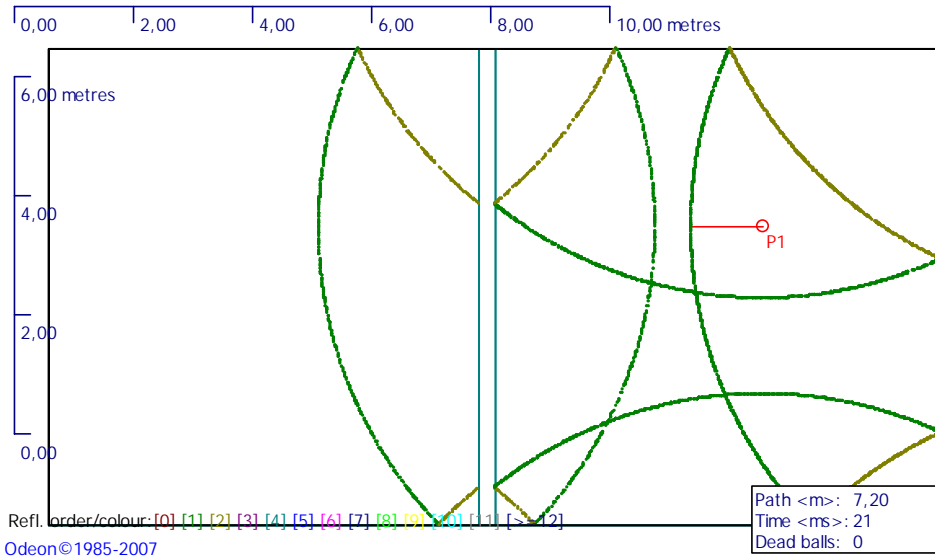

Figur D2 3DBilliard display illustrating Transmission through a double sided wall – as can be seen, ODEON understands correctly that balls should jump through the wall, from one surface to another.

The principle of calculations is shown in figure D2. Statistically 50% of the ball (rays) are transmitted and 50% are reflected. However this is compensated for in the calculations, so the energy losses in the two rooms are determined by the absorption coefficients and reduction indexes, as used.

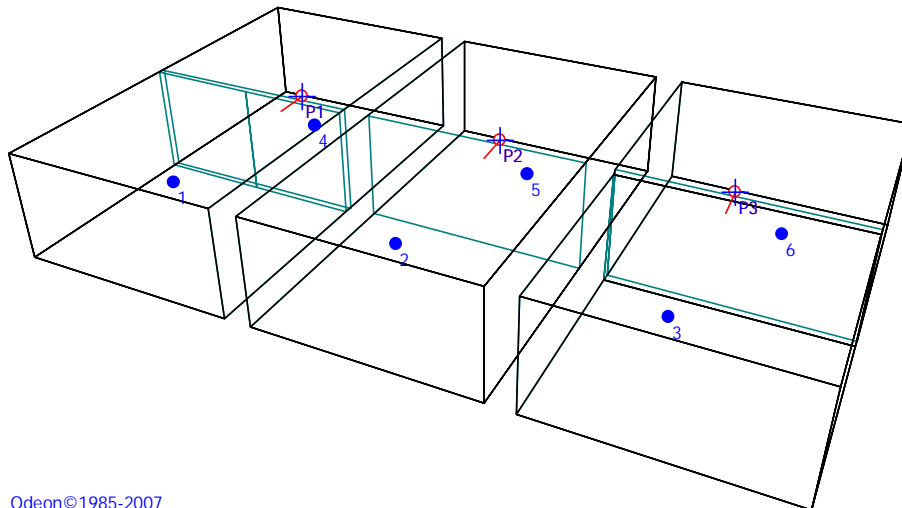

Odeon©1985-2007

Figur D3 The Transmission Rooms.par sample is installed with Odeon. The figure illustrates how transmission data are assigned to transmission walls, when transmission walls are composed from a single surface, two surfaces and three surfaces. Once the room has been loaded into Odeon, additional information is available in the Notes editor using the Shift+Ctrl+N shortcut. In the Joblist, some example setups have been prepared for calculations in source as well as in receiver rooms.