

University of Massachusetts Amherst
ScholarWorks@UMass Amherst

Chemistry Department Faculty Publication Series

Chemistry

1996

Determination of arsenic in gold by flow injection inductively coupled plasma mass spectrometry with matrix removal by reductive precipitation

P BecotteHaigh

JF Tyson

E Denoyer

MW Hinds

Follow this and additional works at: https://scholarworks.umass.edu/chem_faculty_pubs

Recommended Citation

BecotteHaigh, P; Tyson, JF; Denoyer, E; and Hinds, MW, "Determination of arsenic in gold by flow injection inductively coupled plasma mass spectrometry with matrix removal by reductive precipitation" (1996). *SPECTROCHIMICA ACTA PART B-ATOMIC SPECTROSCOPY*. 1078.

Retrieved from https://scholarworks.umass.edu/chem_faculty_pubs/1078

This Article is brought to you for free and open access by the Chemistry at ScholarWorks@UMass Amherst. It has been accepted for inclusion in Chemistry Department Faculty Publication Series by an authorized administrator of ScholarWorks@UMass Amherst. For more information, please contact scholarworks@library.umass.edu.

Determination of arsenic in gold by flow injection inductively coupled plasma mass spectrometry with matrix removal by reductive precipitation

Paul Becotte-Haigh^a, Julian F. Tyson^{a,*}, Eric Denoyer^b, Michael W. Hinds^c

^a*Department of Chemistry, Box 34510, University of Massachusetts, Amherst, MA 01003-4510, USA*

^b*Perkin-Elmer Corporation, 761 Main Ave., Norwalk, CT 06859, USA*

^c*Royal Canadian Mint, 320 Sussex Drive, Ottawa, Ont. K1A 0G8, Canada*

Received 19 March 1996; accepted 22 April 1996

Abstract

Arsenic was determined in gold by flow injection hydride generation inductively coupled plasma-mass spectrometry following a batch mode reductive precipitation removal of the interfering gold matrix. A solution of potassium iodide, L-ascorbic acid, and hydrochloric acid was used as the reductant. The recovery of gold by precipitation and filtration was $99 \pm 3\%$. The detection limit for arsenic in gold was 55 ng g^{-1} in the solid. The concentration of arsenic that was determined in the Royal Canadian Mint gold sample FAU-10 was $29.7 \text{ } \mu\text{g g}^{-1}$ in the solid; this value was indistinguishable, with 95% confidence, from values determined at the Royal Canadian Mint by graphite furnace atomic absorption spectrometry and by inductively coupled plasma-mass spectrometry. The standard deviation for four replicate determinations of the arsenic in FAU-10 was $0.972 \text{ } \mu\text{g g}^{-1}$ in the solid.

Keywords: Arsenic; Flow injection; Hydride generation; ICP-MS; Matrix removal; Reductive precipitation

1. Introduction

The determination of the common impurities in gold is important in assessing the value, physical properties, and point of origin of a sample of gold [1–3]. Arsenic is often present at ppm concentrations in gold. Digestion and dilution of the sample further reduce the concentration of arsenic to be determined, creating a need for a very sensitive analytical method. A method for this determination should also be precise so that sample homogeneity may be determined

[1]. In addition, the method should require a small sample size in order to minimize the cost.

Electrothermal atomic absorption spectrometry (ET-AAS) with batch anion-exchange removal of the gold matrix [4], and laser ablation inductively coupled plasma mass spectrometry (LA-ICP-MS) [1,3] have both been used to determine trace elements in gold samples. Some of the advantages of the LA-ICP-MS method are: solid sampling, microsampling, sensitivity, and multi-element capability. The main drawbacks to LA-ICP-MS are the lack of suitable calibration and certified reference materials, and poorer precision relative to solution analysis [5].

A method for trace element determinations in gold using direct nebulization into the ICP-MS would

* Corresponding author.

potentially suffer from several interferences. The conventional aqua regia gold digestion procedure introduces Cl^- , which produces the polyatomic interference $^{40}\text{Ar}^{35}\text{Cl}^+$ on mono-isotopic $^{75}\text{As}^+$. The total dissolved solids should not exceed 0.1–0.5% m/m in the diluted sample or deposition of material on the sample and skimmer cones will cause drift and sensitivity loss problems [5–7]. Dilution of the matrix to reduce the total dissolved solids also dilutes the arsenic. Gold introduced could also suppress the analyte signal by its space charge effect [8–10].

The application of flow injection (FI) techniques to atomic spectroscopy in order to reduce interferences is well documented [11–17]. Several workers have applied FI to ICP–MS [5,7,18–21]. Sample and reagent consumption, as well as the total amount of dissolved solids that enter the ICP–MS are reduced with FI techniques.

Hydride generation (HG) is often used to increase the transport efficiency and therefore the sensitivity for certain vapor forming elements, such as As [18,20,22]. Another advantage of HG is that the analyte is removed from interfering matrix constituents. A depressive interference upon the hydride signal is often encountered, however, because of the adsorption of the hydride on finely divided transition metal particles that may be precipitated by the reluctant [23,24]. Preliminary experiments had shown this to be the case for the determination of As in gold [25], despite the successful use of the kinetic discrimination with a FI system for the determination of As in nickel [26].

Table 1
Operating conditions for the Elan 5000

<i>Instrumental parameters</i>	
r.f. power/W	1000
Argon gas flow:	
Outer gas flow rate/(l min ⁻¹)	15
Intermediate gas flow rate/(l min ⁻¹)	0.80
Aerosol carrier gas flow rate/(l min ⁻¹)	0.9–1.1
Sample and skimmer cones	nickel
Mass spectrometer running pressure/Pa	130×10^{-6}
<i>Data acquisition parameters</i>	
Mode	Peak hop transient
Dwell time/ms	40
Points per peak	1
Readings per replicate	250
Number of replicates	5

The Royal Canadian Mint (RCM) requires a method for the determination of As in the range 1–50 $\mu\text{g g}^{-1}$ range in gold laser ablation standards. A graphite furnace method for this determination exists, but the characterization of reference materials necessitates a number of validations.

The aim of this study was the development of an FI–HG–ICP–MS method for the determination of As in RCM gold standards. A batch mode precipitation procedure for the removal of gold, which interferes with HG, is described.

2. Experimental

2.1. Instrumentation

An Elan 5000 ICP mass spectrometer (Perkin-Elmer SCIEX, Norwalk, CT, USA) equipped with a FIAS-200 (Bodenseewerk Perkin-Elmer, Überlingen, Germany) was used for this work. The ICP–MS operating conditions are summarized in Table 1. The operating conditions (nebulizer flow and ion optics settings) were optimized by pumping a 1 ppb (m/m) As(III) standard through the carrier line, and generating the hydride continuously. The sensitivity observed during this optimization was more than adequate for the analysis, so that the reagent concentrations and manifold parameters did not have to be optimized further. The FIAS operating program is summarized in Table 2.

The FI manifold is shown in Fig. 1. The gas–liquid separator (GLS) (Perkin-Elmer, Norwalk, CT, USA) is the same as the one described by Welz and Schubert-Jacobs [27], except that the device was filled with glass beads to the top of the waste drain. The nebulizer was replaced with a Teflon adapter that screwed directly to the torch mount and had a 2 mm i.d. central channel. The GLS was connected directly to the Teflon torch adapter via 1 m of 1.24 mm i.d. Teflon tubing. The injection volume was 500 μl .

2.2. Reagents and sample preparation

All reagents were of analytical reagent grade unless otherwise stated. All reagents and samples were prepared with distilled, deionized water (E-Pure, Barnsted, Boston, MA). Fisher Scientific (Fair

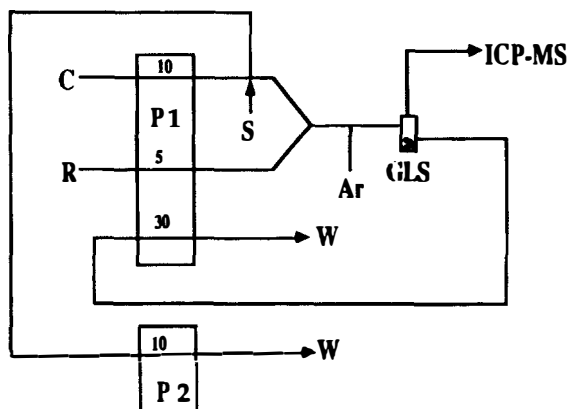

Fig. 1. Flow injection manifold for hydride generation ICP-MS. All manifold tubing was 0.762 mm i.d. The length of the tubing between the acid carrier and reductant merging point and argon addition point was 8 cm. The length of the tubing between the argon addition point and the gas-liquid separator was 30 cm. C: 10% HCl carrier stream; R: NaBH₄ reductant stream; S: sample injected (500 μ l); W: waste; P1 and P2: pumps; GLS: gas-liquid separator; Ar: argon purge stream. Reagent and waste flow rates are shown on the pumps in ml min⁻¹.

Lawn, NJ, USA) brand concentrated hydrochloric and nitric acids were used throughout this work.

The sodium tetrahydroborate solution was prepared fresh daily by dissolving sodium tetrahydroborate (Fisher Scientific) in 0.05% (m/m) sodium hydroxide (certified, Fisher Scientific), then suction filtering the solution through #1 Whatman filter paper. A 1000 ppm (m/v) stock solution of As(V) was prepared by dissolving sodium arsenate (certified, Fisher) in 10% (v/v) nitric acid. A 500 ppb (m/m) As(III) stock solution was prepared by adding 20 ml of 10% (m/v) potassium iodide (Aldrich, Milwaukee, WI) 10% L-ascorbic acid (Fisher), and 20 ml concentrated hydrochloric acid to 0.1 ml of the 1000 ppm (m/v) As(V) stock solution in a 250 ml Nalgene bottle, diluting to 200 g, and allowing the solution to stand for 45 min.

Four portions of the gold sample, each between 0.05 and 0.17 g (FAU-10, 29.4 ppm (m/m) As) supplied by the Royal Canadian Mint (RCM) were each dissolved by placing the material in a 50 ml beaker with 1 ml concentrated nitric acid and 3 ml concentrated hydrochloric acid, covering with a watchglass, and heating slowly until the resulting solution evaporated to approximately half of its original volume. Each solution was then diluted with 1% (v/v) hydrochloric acid to yield a yellow solution containing 0.05% Au (m/m). Forty gram aliquots of the 0.05% (m/m) FAU-10 sample solutions were reduced by adding 20 ml of 10% (m/v) L-ascorbic acid, 10% (m/v) KI solution, 20 ml hydrochloric acid and diluting to 200 g. An opaque brown precipitate formed in the samples upon the addition of the KI/L-ascorbic acid solution. This precipitate was removed by filtering through glass wool, dissolved in aqua regia, and diluted to 200 ml to produce a yellow solution. The precipitate immediately assumed a metallic gold appearance on addition of aqua regia. A 0.1 ml aliquot of the solution in which the precipitate was dissolved was diluted to 100 g. The filtrate was clear and colorless.

2.3. Standards

Standards were prepared by dissolving and pre-reducing/filtering 0.082 g high purity gold (99.999%, RCM) in the same manner as the samples, and adding appropriate amounts of the 500 ppb (m/m) As(III) standard before the final dilution, to produce 0, 0.99, 2.5 and 5.0 ppb (m/m) As(III) standards. This procedure was followed in an attempt to match the sample matrix composition. These calibration standards were used for the determination of As in the samples. A set of calibration standards was prepared by spiking 10% hydrochloric acid with the 500 ppb (m/m) As(III) solution to produce 0, 1.0, 2.0, 4.0 and 6.0 ppb (m/m) As(III) standards for comparison with

Table 2
FIAS 200 program

Step	Time/s	Pump 1/(rev min ⁻¹)	Pump 2/(rev min ⁻¹)	Valve position
Pre-sample	20	120	120	Rinse/fill loop
1	20	120	100	Fill loop
2	15	120	0	Inject

Table 3
Results (in $\mu\text{g/g}$) for the determination of As in FAU-10

Method	Concentration determined	Standard Dev.	Replicates
FI-HG-ICP-MS with pre-reduction	29.7	0.972	4
ICP-MS	28.3	1.26	8
GFAAS ^a	30.4	1.10	10

^a Data obtained by the Royal Canadian Mint.

the matrix matched standards. Another set of calibration standards (0, 0.053, 0.026, 0.13, 0.26, 0.93 and 3.5 ppb (m/m) As(III) was subsequently prepared by pre-reducing and spiking gold solutions to investigate the calibration response at lower concentrations, and to calculate a detection limit. A 10 ppb (m/m) gold solution was prepared as a single point calibration for the determination of the gold recovery by the precipitation. The gold determination was performed by FI ICP-MS with a single-line manifold. The gold content in a prerduced/filtered sample was also determined by this method.

3. Results and discussion

When a sample containing gold was injected a black precipitate formed downstream of the confluence point at which the sodium tetrahydroborate solution was merged. Once this precipitate formed subsequent injections of samples and standards gave no signal. It was hoped that this gold interference would be eliminated by separation of the gold by precipitation during sample pretreatment. However, it was considered possible that arsenic might co-precipitate with the gold, leading to inaccurate determinations.

3.1. Gold recovery

The concentration of gold in the solution in which the precipitate was dissolved would be 500 ppb (m/m) if all of the gold was recovered by the precipitation/filtration/dissolution procedure mentioned above. The gold content of the solution was 492 ± 16 ppb (m/m). This value corresponds to $99 \pm 3\%$ recovery (95% confidence). The gold content of a pre-reduced/filtered sample solution was

determined to be 5.1 ± 0.8 ppb (m/m, 95% confidence). Gold was shown to be completely removed from the matrix by a batch mode reduction prior to analysis.

3.2. Determination of arsenic

The results for the determination of arsenic in FAU-10 gold by FI-HG-ICP-MS are compared with the values obtained by the RCM by ICP-MS and graphite furnace atomic absorption spectrometry (GFAAS) in Table 3. The values determined in this work are indistinguishable from the values determined by the RCM, with 95% confidence. Therefore, arsenic was not lost during the gold precipitation.

The sensitivity of the matrix matched standards calibration was 200 kilo counts per second (kcps) per ppb As(III), as compared to 180 kcps per ppb As(III) for the non-matrix matched standards. The difference between these values may be due to the instrumental drift that was observed. The correlation coefficient for each of these calibrations was greater than 0.9999. Approximately 60 injections per hour were possible with the FIAS program used.

The calibration that was performed using the lower concentration matrix-matched standards had a correlation coefficient of 0.999. The detection limit for this method, based upon 3 standard deviations of the blank response, was 55 ppb (m/m) As in the solid sample. Since the RCM requires that the method detect arsenic at concentrations down to 1 ppm (m/m) in the solid, this method would be adequate for their purposes.

Acknowledgements

The provision and maintenance of the Perkin-Elmer Sciex Elan 5000 and FIAS 200 instruments at the

Amherst campus by Perkin-Elmer are gratefully acknowledged.

References

- [1] V.V. Kogan, M.W. Hinds and G.I. Ramendik, *Spectrochim. Acta Part B*, 49 (1994) 333.
- [2] R.J. Puddephatt, *The Chemistry of Gold*, Elsevier, Amsterdam, 1978.
- [3] R.J. Watling, H.K. Herbert, D. Delev and I.D. Abell, *Spectrochim. Acta Part B*, 49 (1994) 219.
- [4] E. Ivanova and H. Berndt, *Fresenius J. Anal. Chem.*, 340 (1991) 419.
- [5] P. Richner, *J. Anal. At. Spectrom.*, 8 (1993) 927.
- [6] C.W. McLeod, *J. Anal. At. Spectrom.*, 2 (1987) 549.
- [7] A.G. Coedo and M.T. Dorado, *J. Anal. At. Spectrom.*, 9 (1994) 1111.
- [8] E.H. Evans and J.J. Giglio, *J. Anal. At. Spectrom.*, 8 (1993) 1.
- [9] G.R. Gillson and J.E. Douglas, *Anal. Chem.*, 60 (1988) 1472.
- [10] S.D. Tanner, L.M. Cousins and D.J. Douglas, *Appl. Spectrosc.*, 48 (1994) 1367.
- [11] J. Ruzicka and E.H. Hansen, *Anal. Chim. Acta*, 78 (1975) 145.
- [12] J. Ruzicka and E.H. Hansen, *Anal. Chim. Acta*, 179 (1986) 1.
- [13] K.K. Stewart, *Anal. Chem.*, 55, 931A (1983).
- [14] C.B. Ranger, *Anal. Chem.*, 53, 20A (1981).
- [15] J.F. Tyson, *Analyst*, 110 (1985) 419.
- [16] J.F. Tyson, S.R. Bysouth, E.A. Greszczyk and E. Debrah, *Anal. Chim. Acta*, 261 (1992) 75.
- [17] L. Nord and B. Karlberg, *Anal. Chim. Acta*, 145 (1983) 151.
- [18] A. Stroh and U. Vollkopf, *J. Anal. At. Spectrom.*, 8 (1993) 35.
- [19] S. Dadfarnia and C.W. McLeod, *Appl. Spectrosc.*, 48 (1994) 1331.
- [20] J.R. Dean, H.G.M. Parry, R.C. Massey and L. Ebdon, *ICP Information Newsletter*, 15 (1990) 569.
- [21] E.R. Denoyer and Q. Lu, *Atomic Spectrosc.*, 14 (1993) 162.
- [22] S. Branch, W.T. Corns, L. Ebdon, S. Hill and P. O'Neill, *J. Anal. At. Spectrom.*, 6 (1991) 155.
- [23] B. Welz and M. Schubert-Jacobs, *J. Anal. At. Spectrom.*, 1 (1986) 23.
- [24] B. Welz and M. Melcher, *Analyst*, 109 (1984) 569.
- [25] C.P. Hanna, PhD dissertation, University of Massachusetts (1993).
- [26] C.P. Hanna, J.F. Tyson and S.G. Offley, *Spectrochim. Acta Part B*, 47 (1992) 1065.
- [27] B. Weiz and M. Schubert-Jacobs, *At. Spectrosc.*, 12 (1991) 91.