

2010

Rethinking Reiche

Tracie J. Reed

University of Massachusetts Amherst

Follow this and additional works at: <https://scholarworks.umass.edu/theses>

 Part of the [Architecture Commons](#), [Education Policy Commons](#), [Elementary Education and Teaching Commons](#), [Urban Education Commons](#), and the [Urban Studies Commons](#)

Reed, Tracie J., "Rethinking Reiche" (2010). *Masters Theses 1911 - February 2014*. 462.
Retrieved from <https://scholarworks.umass.edu/theses/462>

This thesis is brought to you for free and open access by ScholarWorks@UMass Amherst. It has been accepted for inclusion in Masters Theses 1911 - February 2014 by an authorized administrator of ScholarWorks@UMass Amherst. For more information, please contact scholarworks@library.umass.edu.

RETHINKING REICHE

A Thesis Presented

by

Tracie J. Reed

Submitted to the Graduate School of the
University of Massachusetts Amherst in partial fulfillment
of the requirements for the degree of

MASTER OF ARCHITECTURE

May 2010

Architecture + Design Program
Department of Art, Architecture and Art History

RETHINKING REICHE

A Thesis Presented

By

Tracie J. Reed

Approved as to style and content by:

Stephen Schreiber, Chair

Kathleen Lugosch, Member

Ray K. Mann, Graduate Program Director
Art, Architecture, and Art History

William T. Oedel, Chair,
Art, Architecture, and Art History

DEDICATION

This project is dedicated to my husband, Joshua Reed, and feline companion, Boots, for their steadfast support, love and encouragement throughout the completion of this project.

This project is also dedicated to the citizens of Portland, Maine. Not a day has gone by during my three-year program that I have not missed my dear Portland friends, and Portland's renowned restaurants, sandy beaches, cobblestone streets, feral wharf cats, local produce and singing seagulls, not to mention sailing on Portland's rocky Casco Bay and the Gulf of Maine. . .

Within Portland, my heart belongs in the West End, home of the Howard C. Reiche Community School. The heart of our community, Reiche School, was an obvious choice for my thesis project. I hope that this project proves a useful tool for discussion and reflection as our community works to Rethink Reiche in coming years.

ACKNOWLEDGEMENTS

Analysis of LEED and BREEAM Assessment Methods for Educational Institutions was published by the Journal of Green Building in their Winter 2010 issue.

My co-authors on this paper were:

Peggi L. Clouston, P.Eng., Ph.D., Associate Professor, Dept. of Natural Resources Conservation Simi Hoque, Ph.D., Assistant Professor, Dept. of Natural Resources Conservation

Paul R. Fiset, Professor and Department Head, Dept. of Natural Resources Conservation

I would like to thank all of my co-authors for their advice and assistance with this paper. I would like to especially thank Dr. Peggi L. Clouston, my primary advisor, for encouraging me to have the paper published and for guiding me through the submission and peer-review process.

I would also like to acknowledge and thank Portland Architect Alan Holt for meeting with me and sharing data he and his students at the University of Southern Maine's Muskie School of Public Service assembled for a workshop on the Reiche Community Center which occurred in 2006. Alan provided programmatic space use data on Reiche, historical maps of the site as well as AutoCAD drawings of the current building for which I based my models.

I would also like to thank Douglas Sherwood, the Portland School District's Facilities Director for taking me on a tour of the elementary school, describing the District's priorities and providing me with elevations and sections of the school.

ABSTRACT

RETHINKING REICHE

MAY 2010

TRACIE J. REED, B.A., THE EVERGREEN STATE COLLEGE

M.St. IDBE, UNIVERSITY OF CAMBRIDGE (UK)

M. ARCH., UNIVERSITY OF MASSACHUSETTS AMHERST

Directed by: Professor Stephen Schreiber, FAIA

Chapter I of the study examines the differences between two environmental assessment methods for the K-12 education sector: the United States Green Building Council's (USGBC) LEED Schools Version 3.0 and the British Research Establishment's (BRE) BREEAM Education issue 2.0. Credit requirements are compared side-by-side and against recommendations from researchers in areas such as acoustics, lighting and indoor environment quality. Strengths in the two schemes and areas for improvement are highlighted, with acknowledgement that each scheme offers components and techniques from which the other could benefit.

Chapter II of the study introduces the Howard C. Reiche Community School in Portland, Maine. Designed as an open-plan school in the 1970's this configuration is currently seen as a barrier to teaching and learning in the school which is slated for renovation by the Portland Public School District. Part III of the study looks towards precedents in education which have followed either the LEED or BREEAM assessment methods and Part IV of the study provides a design proposal for the Howard C. Reiche Community School's renovation.

TABLE OF CONTENTS

	Page
ACKNOWLEDGEMENTS	iv
ABSTRACT	v
LIST OF TABLES	ix
LIST OF FIGURES	x
CHAPTER	
I. AN ANALYSIS OF LEED AND BREEAM ASSESSMENT METHODS FOR EDUCATIONAL	
INSTITUTIONS.....	1
Introduction	1
LEED Versus BREEAM Rating Schemes	1
Building Certification	3
LEED Schools versus BREEAM Education Credit Comparison.....	3
Design Phase and Operation.....	3
Site Selection.....	5
Water Efficiency.....	7
Energy & Atmosphere.....	8
Indoor Air Quality	12
Materials & Resources	17
Lighting, Daylighting and Views	20
Acoustics	22
Transportation	23
Innovation & Education	25
Conclusions	25
Strengths of BREEAM.....	25
Strengths of LEED.....	26
Room for improvement	26
References	28
II. RETHINKING REICHE.....	32
The City of Portland, Maine and the Portland Public School District	32
Howard C. Reiche Community School	32

Howard C. Reiche Community School Program Needs.....	35
The Building Site	36
Reiche School’s Current Energy Consumption	36
Design Considerations	37
Building/Code Requirements for City of Portland, Maine	37
Acknowledgements.....	37
References	38
III. PRECEDENT STUDIES.....	39
Introduction	39
The Schools	39
Bethke Elementary School.....	39
St. Thomas School.....	41
Rosa Parks School	43
New Minster School.....	45
Kingsmead Primary School	48
Bridge Academy	50
Acknowledgements.....	51
References	52
IV. RETHINKING REICHE RENOVATION PROPOSAL	54
Project Introduction.....	54
Educational Philosophy Guiding Design.....	55
Community Center Design Workshop – 2006	55
Vision Statements	55
Site Analysis Conclusions	55
Types of activities taking place at the Community Center	56
Design Program Requirements	57
Design Interventions.....	58
Accessibility.....	58
Exterior.....	58
Classrooms	59
Windows	61
Lunchroom.....	62
Library	63
Community Center.....	63
Material Selection and Mechanical Services	63
Envelope	63
Fenestrations	64
Flooring	65
Wall Products and Casework	65

Site Considerations	65
Heating, Ventilation and Air Conditioning	65
Safety and Access.....	66
Transportation and Site Circulation	66
Conclusion.....	67
References	68
Thesis Oral Presentation Boards.....	69
APPENDICES	
I. SITE PLAN	77
II. PRESENT SITE CONDITION PHOTOGRAPHS.....	78
III. HISTORIC SITE MAPS I	79
IV. HISTORIC SITE MAPS II	80
V. INTERIOR PHOTOGRAPHS.....	81
VI. CURRENT EXTERIOR CONDITION PHOTOGRAPHS	82
VII. SITE EDGE CONDITION PHOTOGRAPHS.....	83
VIII. LEED 2009 FOR SCHOOLS NEW CONSTRUCTION AND MAJOR RENOVATION PROJECT CHECKLIST.....	84
IX. NEIGHBORHOOD CONTEXT DIAGRAM.....	85
X. MOVEMENT AND ACTIVITY DIAGRAMS.....	86
XI. SITE PLAN	87
XII. FIRST FLOOR PLAN	88
XIII. SECOND FLOOR PLAN	89
XIV. ELEVATIONS	90
XV. SECTIONS	91
XVI. CLASSROOM PERSPECTIVES.....	92
XVII. KINDERGARTEN READING AREA AND LIBRARY PERSPECTIVES	93
BIBLIOGRAPHY	94

LIST OF TABLES

Table	Page
1. Categories into which LEED and BREEAM have divided their points.....	2
2. Design Phase and Operation Comparison	3
3. Site Selection Comparison	5
4. Water Efficiency Comparison.....	7
5. Energy and Atmosphere Comparison	8
6. Indoor Air Quality Comparison	12
7. Materials and Resources Comparison	17
8. Lighting, Daylighting and Views Comparison	20
9. Acoustics Comparison	22
10 Transportation	23
11. Current Program Distribution	35
12. Precedent Project Overview	39
13. Design Program Requirements	57

LIST OF FIGURES

Figure	Page
1. Comparison of program changes over the last 40-50 years	34
2. Bethke Elementary School entrance.....	40
3. Bethke Elementary School Floor Plan	41
4. Bethke Elementary School Stairwell	41
5. St. Thomas School Cafeteria and Gymnasium	42
6. St. Thomas School Passive Energy Diagram.....	43
7. Rosa Parks School.....	44
8. Rosa Parks Elementary School Plans.....	45
9. Concept illustrating heartspace, spatial organization and transportation plan	46
10. Axonometric Cutaway illustrating the 8 meter wide heartspace and public areas.....	46
11. Heart space, New Minster School.....	47
12. New Mister School.....	48
13. Kingsmead Primary School, Glulamated Structure during construction	49
14. Kingsmead Primary School Plan.....	50
15. Bridge Academy Aerial Photo	50
16. Bridge Academy from across the canal.....	51
17. Sectional Diagram	51
18. Accessibility	58
19 Proposed Brackett Street Perspective	59
20. Proposed Community Center Entrance	59
21. Interior Classroom Perspective.....	60
22. Proposed Classroom Windows	60
23. Kindergarten Reading Area	61

24. Library Perspective..... 62

25. Existing Community Center Entrance 63

CHAPTER I

AN ANALYSIS OF LEED AND BREEAM ASSESSMENT METHODS FOR EDUCATIONAL INSTITUTIONS

Introduction

In the United States there are approximately 49 million students in the K-12 education system (US Dept. of Education 2006-07). A mid-1990's report by the United States General Accounting Office found 14 million students attend roughly 25,000 schools with substandard conditions (1995). Thus, improving the quality of schools has the ability to have a real and lasting impact on our communities.

In the last twenty years, methods of assessing green building design and sustainable living has received increased attention (NRC, 2007). Currently, there are seven states and seven counties or school districts that require LEED certification for new schools, and many more are considering joining suit (USGBC, 2009). The UK's Department for Children, Schools and Families has established mandatory sustainability targets with the intention that all new schools will be zero carbon by 2016 (minimum BREEAM 'Very Good') (British Research Establishment (BRE) 2009).

The United Kingdom is credited with developing the first environmental assessment method in 1990, the British Research Establishment's Environmental Assessment Method (BREEAM) (Howard, 2005). This system was used by many countries, including the US in developing their assessment methods (Scheuer²⁰⁰²). BREEAM's latest version Issue 2.0 was introduced in summer 2008. In the United States the predominant environmental assessment method is the US Green Building Council's (USGBC) Leadership Energy and Environmental Design (LEED) system. LEED's latest version, v3.0 was released in May 2009.

Both BREEAM and LEED have specific schemes addressing school design, which prompt the questions: what are the similarities and differences in these two systems? And, what are the strengths and weaknesses in the two systems?

Several researchers have completed comparisons of environmental assessment methods, including LEED and BREEAM (Lee & Burnett, 2008; Haapio & Viitaniemi, 2008; Harputlugil & Hensen, 2006). BREEAM distributes such a comparison, published in Sustainability Magazine, on their BRE Global website (2006). These comparisons, however, have not been related specifically to LEED and BREEAM's education schemes.

Reports in the UK and US, such as the National Research Council's 2007 report, *Green Schools: Attributes for Health and Learning*, and UK's Department for Children and Families, *Schools for the Future* reports, have examined the social and environmental benefits of high performance schools [sustainable schools].

There are many similarities between the two schemes. For instance, both assessment models cover similar sections such as energy, sustainable sites, renewable materials, etc. and have similar points based rating systems and tiered certification systems (Pass, Good, Very Good, Excellent or Outstanding rating for BREEAM and Certified, Silver, Gold, Platinum for LEED). However, there are also notable differences. This study identifies specific strengths of the two systems to identify issues that are not fully or partially addressed, by one or both systems.

LEED Versus BREEAM Rating Schemes

Since the development of LEED was influenced by BREEAM (Scheuer, 2002) the two schemes share many similarities. These include varying tiers of certification and point classification structures. Currently, they have the following tiers:

LEED

Certified 40–49 points

Silver 50–59 points

Gold 60–79 points

Platinum 80+ points

BREEAM

Pass ≥ 30%

Good ≥ 45%

Very Good ≥ 55%

Excellent ≥ 70%

Outstanding ≥ 85%

Table 1: Categories into which LEED and BREEAM have divided their points

LEED	Points	%
Sustainable Sites-SS	24	22%
Water Efficiency-WE	11	10%
Energy & Atmosphere -EA	33	30%
Materials & Resources-MR	13	12%
Indoor Environmental Quality-IEQ	19	17%
Innovation and Design	6	5%
Regional Priority	4	4%

BREEAM	%*
Land Use and Ecology-LE	10%
Water-Wat	6%
Energy-Ene	19%
Materials-Mat	12.5%
Health and Wellbeing-Hea	15%
Transport-Tra	8%
Waste-Wst	7.5%
Pollution-Pol	10%
Management-Man	12%
Innovation	10%

*New buildings, extensions, major refurbishments

Referencing Table 1, LEED and BREEAM have different definitions of their credit category parameters, for example; site selection is addressed by LEED in Sustainable Sites while BREEAM addresses it in Management. In order to compare the schemes, credits were realigned into the following categories so various issues could be compared side-by-side. New categories:

- Acoustics
- Design Planning & Bldg. Operation
- Energy & Atmosphere
- Indoor Air Quality
- Lighting & Daylighting
- Materials & Resources
- Site
- Transport
- Water Efficiency
- Innovation & Education

Building Certification

To obtain LEED certification, projects must meet ten prerequisites (PR) across 5 of the categories; these do not provide points. BREEAM's prerequisites depend on the certification tier the project hopes to achieve. Wat 1 is not compulsory for 'Pass' projects, but for 'good' ones it becomes compulsory. Points are provided for compulsory credits. There are three credits required to achieve a pass rating, making them essentially prerequisites. LEED has 110 points possible and BREEAM has 110% possible¹

LEED Schools versus BREEAM Education Credit Comparison

The following sections compare LEED Schools v3.0 and BREEAM Schools Issue 2.0. Credit requirements are from LEED 2009 for Schools: New Construction and Major Renovations Rating System (USGBC, 2009) and the BREEAM Education 2008 Assessors Manual (BREEAM, 2008) with abbreviations where possible.

To provide a rational credit comparison to LEED, BREEAM's credits were weighted to reflect the BREEAM section weights. For example, the Water section has 8 points possible and a section weight of 6% so each credit earned in this category is worth 0.75 points taking the section weight into consideration.

Design Phase and Operation

Table 2 and the discussion that follows cover the issues of engaging others in the design process and ensuring that the building operates smoothly once constructed.

Table 2 – Design Phase and Operation Comparison

LEED Schools version 3.0	BREEAM Education Issue 2.0
	<u>Man 2 (.6-1.2) - Considerate Constructors</u> : Employ best practice site management principles. Point 2: Beyond best practice principles.
	<u>Man 8 (.6) - Security</u> : Consult with local police at the design stage and incorporate their recommendations into the building and parking design.
	<u>Man 11 (.6) - Ease of maintenance</u> : Use best practice methods for considering ease and efficiency of maintenance in building services/systems and landscaping specification.
	<u>Man 12 (.6-1.2) - Life cycle costing</u> : Conduct/implement a LLC analysis.
	<u>Ene 2 (.73) - Sub-metering of substantial energy uses (VG+)</u> : Separate and accessible energy sub-meters for: Space Heating, Domestic Hot Water, Humidification, Cooling, Fans (major), Lighting, Small Power systems. Should have pulsed output to

¹ BREEAM's core credits are weighted out of 100% possible. An addition of 10% points can be achieved above this threshold for exemplary or innovative credits. Each innovation credit is worth 1% each.

	enable connection to a building management system.
	<u>Ene 3 (.73) - Sub-metering of high energy load and tenancy areas:</u> Sub-metering of energy consumption by tenancy/building function area.
	<u>Wat 2 (.75) – Water meter (G+):</u> Water meter with a pulsed output on the mains supply.
	<u>Wat 3 (.75) - Major leak detection:</u> Leak detection system on the main supply.
	<u>Wat 4 (.75) - Sanitary supply shut-off:</u> Proximity detection shut-off to the water supply to all toilet areas.
	<u>LE 7 (.83) - Consultation with students and staff:</u> Consult with staff and pupils, to determine their (i) educational and social requirements, (ii) ideas for the design and (iii) keep them informed of how their ideas are integrated.
	<u>LE 8 (.83) - Local wildlife partnerships:</u> For partnership with a local group with wildlife expertise.
	<u>Pol 2 (.71) - Preventing refrigerant leaks:</u> Refrigerant leaks detection system and the provision of automatic refrigerant pump down is made to a heat exchanger (or dedicated storage tanks) with isolation valves. Or where there are no refrigerants specified.

Evident from Table 2, BREEAM emphasizes ensuring the building is easy to maintain and monitor for energy efficiency. It should be noted that only Ene 2 and Wat 2 are compulsory for ‘very good’ and ‘good’ projects (or better), respectively. These credits are essential to ensuring the building is operating effectively after its construction, which is essential to student health and comfort (National Forum on Education Statistics, 2003).

The life cycle costing and ease of maintenance credits, provide the biggest potential for developing a sustainable and easily maintainable design, when paired with metering equipment which allows monitoring of the building systems by maintenance personnel. These credits also address key areas critics of LEED feel are weaknesses with LEED’s scheme (Gifford, 2008).

LEED’s lack of credits in this category is obvious from the blank space in Table 2. It has received criticism among practitioners and researchers (Santosa, 2007) for lacking metering credits or accountability post-construction for energy usage. Credits for metering would encourage projects to install metering equipment and complete post-construction monitoring so LEED and owners could assess consumption and the rigor of its energy and water conserving credit requirements over time.

Site Selection

Table 3 and the discussion that follows cover the issues of reducing a project’s impact on its site via selection, contamination cleanup, control of stormwater, and sharing facilities.

Table 3 – Site Selection Comparison

LEED Schools version 3.0	BREEAM Education Issue 2.0
<p><u>SS PR 1 (0) - Construction Activity Pollution Prevention</u>: Implement an erosion and sedimentation control plan for construction activities.</p>	<p>*See Management 3.</p>
<p><u>SS PR 2 (0) - Environmental Site Assessment</u>: Conduct a Phase I ESA to determine whether contamination exists. If contamination is suspected conduct Phase II ESA. Former landfill sites are ineligible for certification. Remediate other contamination to local, state, or federal EPA region residential (unrestricted) standards, (most stringent).</p> <p><u>SS Credit 3 (1) - “Brownfield Redevelopment”</u>: For remediating site contamination.</p>	<p><u>LE3 (.83) - Ecological Value of site AND protection of ecological features</u>: Where the construction site’s zone is defined as land of low ecological value and high ecological value areas protected from damage due from site preparation and construction.</p> <p><u>LE2 (.83) - Contaminated Land</u>: Remediate contamination pre-construction.</p> <p><u>Man 5 (.6) - Site investigation</u>: Complete a detailed site investigation.</p>
<p><u>SS 1 (1) - Site Selection</u>: for not developing on:</p> <ul style="list-style-type: none"> -Prime farmland -Undeveloped land whose elevation $\leq 5'$+ the 100-year flood plane -Endangered species habitat -$\leq 100'$ of wetlands -Undeveloped land $\leq 50'$ from a water body -Public parkland prior to acquisition, unless \geq land is accepted in trade by the public landowner. 	<p><u>LE4 (.83-1.67) - Mitigating ecological impact (VG+)</u>: For minimal change to the site’s ecological value. 2 points: no negative change.</p> <p><u>Pol 5 (.71-1.43) - Flood Risk</u>: For a site with low flood risk or medium-high risk where the building and parking are above this level. Point 2: Ensure peak run-off rate from the site to watercourses does not increase post-development. Comply with Interim Code of Practice for Sustainable Drainage systems (CIRIA, 2004), or for at least a 1 year and 100 year return period event with 6 hour duration.</p>
<p><u>SS 2 (4) - Development Density and Community Connectivity</u>: Previously developed site in a densely developed area (60,000+ ft² per acre net). <u>OR</u> a previously developed site ½ mile from a residential neighborhood with an average density of 10 units/acre net and $\leq ½$ mile of 10+ accessible basic services.</p>	<p><u>Tra 2 (.88) - Proximity to amenities</u>: Build within 500m (1/3 mile) of accessible local amenities appropriate to the building type/users.</p>

<p><u>SS 5.1 (1) - Site Development- Protect or Restore Habitat:</u></p> <p>Greenfield site: limit disturbance to ≤40' around building perimeter. Previously developed/graded site: protect/restore 50%+ of the site, excluding footprint, or 20% including footprint.</p>	<p><u>LE6 (.83-1.67) - Long-term impact on biodiversity:</u> Appoint an ecologist prior to site activity, ecologist confirms compliance with UK and EU legislation on protection and enhancement of ecology during D&C phases, create a landscape and habitat management plan covering 5-years post-occupancy. Point 2: Appoint a 'biodiversity champion', train job crew on protecting site ecology, monitor plan effectiveness, minimizing site disturbance.</p>
<p><u>SS 5.2 (1) - Site Development- Maximize Open Space:</u></p> <p>-With zoning: exceed zoning by 25%</p> <p>-No zoning: equal to the building footprint.</p> <p>-Zoning but no open space requirements: 20% of the site must be open space.</p>	<p><u>LE1 (.83) - Reuse of Land:</u> Majority of footprint on previously developed site.</p> <p><u>LE5 (.83-2.49) - Land Use & Ecology:</u> Appoint a qualified ecologist to advise the designers on enhancing/protecting the site and implement their recommendations. Additional points: increase the ecological value of the site ≤5 species, or 6+ species.</p>
<p><u>SS 6.1 Stormwater Design-Quantity Control:</u> Existing imperviousness ≤50%: no increase in discharge rate and quantity for 1 and 2-year 24-hour design storms. <u>OR</u> implement a plan that protects receiving stream channels from excessive erosion.</p> <p>Existing imperviousness ≥50%: reduce volume by 25% based on 2-year 24-hour design storm.</p> <p><u>SS 6.2 (1) - Stormwater Design-Quality Control</u> Treat 90% of runoff and 80% of average annual post development total suspended solids.</p>	<p><u>Pol 6 (.71) - Minimizing watercourse pollution:</u> Treat stormwater on site to reduce potential for silt, heavy metals, chemicals and oil into the site's habitat.</p> <p>*See Pol 5 point 2: quantity control</p>
<p><u>SS 7.1 (1) - Heat Island Effect-Nonroof:</u> Reduce the heat island effect on 50% of hardscape surfaces.</p> <p><u>SS 7.2 (1) - Heat Island Effect –Roof:</u> Use high SRI products on roof surfaces (29 or 78 depending on slope), a green roof or a combination of green and high SRI roof.</p>	
<p><u>SS 9 (1) - Site Master Plan:</u> Develop a master plan in collaboration with school board. Must receive 4 of 7 credits: SS 1, SS 5.1, SS 5.2, SS 6.1, SS 6.2, SS 7.1 and SS 8.</p>	
<p><u>SS 10 (1) - Joint Use of Facilities:</u> Consult with school board to provide 3+ spaces accessible/available to the public: auditorium, gymnasium, cafeteria, classrooms, playing fields, parking.</p>	<p><u>Man 7 (.6-1.8) - Shared Facilities:</u> Provide shared facilities resulting from consultant feedback. Point 2: Enable access without compromising the safety/security of building occupants.</p>

The glaring differences between the schemes are BREEAM’s lack of credits for reducing the heat island effect and its lack of credit for producing a site master plan, as illustrated in Table 3. In London, the heat island effect is blamed for an increase of 6-8° C in the summer over outlying areas (Greater London Authority, 2006). Addressing the heat island effect would help reduce air conditioning, irrigation requirements, and negative health effects.

The act of producing a site master plan helps encourage school officials and designers to examine the long-term needs of the community and how the site will need to adapt to those needs through time. This is a critical step in ensuring the school will meet the evolving needs of the community (Salvesen, Sachs & Engelbrecht, 2006). BREEAM does encourage design teams to seek input from students and teachers (see previous section) via LE 7. Where LE 7 does not directly appear to affect the sustainability of the building, LEED’s SS 9, does help ensure sustainability is part of the discussion by requiring projects attempting the credit to receive four of seven other credits it deems important in the SS category.

Water Efficiency

Table 4 and the discussion that follows cover the issues of potable water reduction in both landscaping and interior uses and innovative gray water/waste water strategies.

Table 4 – Water Efficiency Comparison

LEED Schools version 3.0	BREEAM Education Issue 2.0
<u>WE PR 1 (0) - Water use reduction:</u> 20% less water than the baseline calculated for the building (excluding irrigation).	<u>Wat 1 (.75-2.25) - Water consumption (G+):</u> Potable water reducing fixtures for taps, urinals, toilets and showers. Points awarded for consumption of: 1: 4.5-5.5m ³ per person/year 2: 1.5-4.4 m ³ per person/year 3: <1.5 m ³ per person/year
<u>WE 1 (2-4) - Water Efficient Landscaping:</u> Reduce potable water needed for irrigation by 50% from calculated mid-summer baseline. Four points: no potable water.	<u>Wat 6 (.75) - Irrigation systems:</u> Install a low-water irrigation strategy/system or using non-potable water.
<u>WE 2 (2) - Innovative Wastewater Technologies:</u> Reduce potable water in building sewage conveyance by 50% through water-conserving fixtures or non-potable water. <u>OR</u> treat 50% of wastewater on-site to tertiary standards for use on site or infiltration.	<u>Wat 5 (.75) - Water Recycling:</u> For collecting, storing, and where necessary treating, rainwater or graywater for toilet and urinal flushing.
<u>WE 3 (2-4) - Water Use Reduction :</u> Reduce potable water consumption for toilets, urinals, sinks, showers, and pre-rinse spray valves. 30% 2 points, 35% 3 points, 40% 4 points.	*see Wat 1: Water consumption
<u>WE 4 (1) - Process Water Use Reduction:</u> No potable	

water for one-through cooling for refrigeration equipment, or garbage disposals. Water conserving process water appliances.	
---	--

Water efficiency is essential to sustainability with regions in both the United States and UK suffering from water scarcity (Environment Agency, 2008 & Postel, 2000).

LEED has stricter irrigation requirements than BREEAM. As illustrated in Table 4, LEED requires achieving a 50% reduction in potable water for irrigation calculated from a mid-summer baseline or, for additional points, no potable water. BREEAM provides a point for potable water reduction but does not specify a specific percentage reduction in consumption, just that a low-water irrigation strategy has been installed, or that planting and landscaping is irrigated via rainwater or reclaimed water.

In addition to water conservation, BREEAM addresses water safety, which is an area not addressed by LEED. BREEAM HEA 12, “Microbial contamination” provides a credit to projects which demonstrate that the risk of waterborne and airborne legionella contamination has been minimized and Hea 16 addresses drinking water access, providing a point to projects where evidence demonstrates that mains-fed point of use water coolers are provided. A main’s fed point of use water cooler is a directly plumbed-in water dispenser that provides chilled and ambient temperature mains-fed water to building users. BREEAM requires that they are attached “to both the wall and the floor to prevent vandalism, and contain security covers to protect all water and electrical connections.”

Energy & Atmosphere

Table 5 – Energy Efficiency Comparison

LEED Schools version 3.0	BREEAM Education Issue 2.0
<p><u>EA PR 1 (0) - Fundamental Commissioning of Building Energy Systems:</u> Appoint CxA to lead, review and oversee commissioning.</p> <ul style="list-style-type: none"> -Experience in 2+ projects. -Independent of the design and construction management team. May be a qualified employee or consultant of owner. -Report results, findings and recommendations directly to owner. -Projects ≤50,000 gross ft²: can be a qualified person on the design or construction team with required experience. -Owner must document the owner’s project requirements. Design team must develop the basis of design. CxA: reviews for clarity/completeness. -Develop/incorporate commissioning requirements 	<p><u>Man 1 (.6-1.2) - Commissioning (P+: .6 O:1.2):</u> Appoint a project team member to monitor commissioning for the client to ensure commissioning will be completed to best practice standards. Point 2: Complete seasonal commissioning during the first year post-occupancy.</p>

<p>into construction documents.</p> <ul style="list-style-type: none"> -Develop/implement a commissioning plan. -Verify installation and performance of the systems for commissioning. -Complete a commissioning report. 																																																										
<p><u>EA PR 2 (0) - Minimum Energy Performance:</u> Establish an energy performance rating goal using EPA’s Target Finder rating tool via one of three options:</p> <ul style="list-style-type: none"> -Whole Building Energy Simulation -Prescriptive Compliance Path (Buildings ≤200,000 ft²) -Prescriptive Compliance Path (Buildings ≤100,000 ft²) 	<p>*See Ene 1</p> <p><u>Ene 8 (.73-1.46) - Lifts:</u> Energy-efficient elevators.</p> <p><u>Ene 11 (.73) - Energy Efficient fume cupboards:</u> Study the most energy-efficient strategy for laboratory fume cupboard ventilation.</p> <p><u>Ene 12 (.73) - Swimming pool ventilation and heat loss:</u> Automatic or semi-automatic pool covers on pools.</p>																																																									
<p><u>EA PR 3 (0) - Fundamental Refrigerant Management:</u> No CFC-refrigerants in building HVAC&R systems. Existing HVAC equipment must phase-out CFC-refrigerants before occupancy.</p>	<p><u>Pol 1 (.71) - Refrigerant GWP - Building Services:</u> Refrigerants with a global warming potential (GWP) of <5. <u>OR</u> no refrigerants for building services.</p> <p><u>Ene 10 (.73) - Free cooling:</u> Incorporate a free cooling strategy that completely displaces need for conventional mechanical cooling system while achieving thermal comfort requirements of Hea 11.</p>																																																									
<p><u>EA 1 (1-19) - Optimize Energy Performance:</u> Select 1 of 3 compliance path options:</p> <ul style="list-style-type: none"> -Whole Building Computer Energy Simulation <table border="1" data-bbox="186 1276 829 1885"> <thead> <tr> <th>New</th> <th>Renovations</th> <th>Points</th> </tr> </thead> <tbody> <tr><td>12%</td><td>8%</td><td>1</td></tr> <tr><td>14%</td><td>10%</td><td>2</td></tr> <tr><td>16%</td><td>12%</td><td>3</td></tr> <tr><td>18%</td><td>14%</td><td>4</td></tr> <tr><td>20%</td><td>16%</td><td>5</td></tr> <tr><td>22%</td><td>18%</td><td>6</td></tr> <tr><td>24%</td><td>20%</td><td>7</td></tr> <tr><td>26%</td><td>22%</td><td>8</td></tr> <tr><td>28%</td><td>24%</td><td>9</td></tr> </tbody> </table>	New	Renovations	Points	12%	8%	1	14%	10%	2	16%	12%	3	18%	14%	4	20%	16%	5	22%	18%	6	24%	20%	7	26%	22%	8	28%	24%	9	<p><u>Ene 1 (.73-11.68) - Reduction of CO₂ emissions (E:4.38 O:7.3):</u> Improve the energy efficiency of the building’s fabric and services to lower CO₂ emissions. Points determined by comparing the building’s Energy Performance Certificate (EPC) with the table below:</p> <table border="1" data-bbox="852 1360 1471 1885"> <thead> <tr> <th colspan="3">CO₂ Index (EPC Rating)</th> </tr> <tr> <th>New</th> <th>Renovation</th> <th>Points</th> </tr> </thead> <tbody> <tr><td>63</td><td>100</td><td>.73</td></tr> <tr><td>53</td><td>87</td><td>1.46</td></tr> <tr><td>47</td><td>74</td><td>2.19</td></tr> <tr><td>45</td><td>61</td><td>2.92</td></tr> <tr><td>43</td><td>50</td><td>3.65</td></tr> <tr><td>40</td><td>47</td><td>4.38</td></tr> <tr><td>37</td><td>44</td><td>5.11</td></tr> </tbody> </table>	CO ₂ Index (EPC Rating)			New	Renovation	Points	63	100	.73	53	87	1.46	47	74	2.19	45	61	2.92	43	50	3.65	40	47	4.38	37	44	5.11
New	Renovations	Points																																																								
12%	8%	1																																																								
14%	10%	2																																																								
16%	12%	3																																																								
18%	14%	4																																																								
20%	16%	5																																																								
22%	18%	6																																																								
24%	20%	7																																																								
26%	22%	8																																																								
28%	24%	9																																																								
CO ₂ Index (EPC Rating)																																																										
New	Renovation	Points																																																								
63	100	.73																																																								
53	87	1.46																																																								
47	74	2.19																																																								
45	61	2.92																																																								
43	50	3.65																																																								
40	47	4.38																																																								
37	44	5.11																																																								

30%	26%	10	31	41	5.84																
32%	28%	11	28	36	6.57																
34%	30%	12	25	31	7.3																
36%	32%	13	23	28	8.03																
38%	34%	14	20	25	9.49																
40%	36%	15	18	22	10.22																
42%	38%	16	10	18	10.95																
44%	40%	17	0	15	11.68																
46%	42%	18	<0	≤0	Exemplar credit 1																
48%	44%	19	True zero carbon building		Exemplar credit 2																
<p>-Prescriptive Compliance Path (1 point: <200,000 ft²):</p> <p>-Prescriptive Compliance Path (1-3 points: <100,000 ft²)</p>			<p>Building must be modeled using a method compliant with the National Calculation Method (NCM) and an Energy Rating and certificate produced using <i>Approved software</i> by an <i>Accredited Energy Assessor</i>.</p>																		
<p><u>EA 2 (1-7) - On-site Renewable Energy: Use on-site renewable energy to offset costs. Percentage of renewable energy compared to annual energy cost.</u></p> <table border="1"> <thead> <tr> <th>Energy</th> <th>Points</th> </tr> </thead> <tbody> <tr> <td>1%:</td> <td>1</td> </tr> <tr> <td>3%:</td> <td>2</td> </tr> <tr> <td>5%:</td> <td>3</td> </tr> <tr> <td>7%:</td> <td>4</td> </tr> <tr> <td>9%:</td> <td>5</td> </tr> <tr> <td>11%:</td> <td>6</td> </tr> <tr> <td>13%:</td> <td>7</td> </tr> </tbody> </table>			Energy	Points	1%:	1	3%:	2	5%:	3	7%:	4	9%:	5	11%:	6	13%:	7	<p><u>Ene 5 (.73-2.19) - Low or zero carbon technologies (E+;.73):</u></p> <p>.73 point: Carry out and implement feasibility study considering <i>on-site</i> and/or <i>near site</i> low or zero carbon (LZC) technologies.</p> <p>1.46 points: 10% CO₂ reduction from installing a feasible local LZC technology. 2.19 points: 15% reduction.</p>		
Energy	Points																				
1%:	1																				
3%:	2																				
5%:	3																				
7%:	4																				
9%:	5																				
11%:	6																				
13%:	7																				
<p><u>EA 3 (2) - Enhanced Commissioning: In addition to EA PR 1:</u></p> <p>-Conduct 1+ commissioning design review of the owner's project requirements basis of design, and design documents prior to mid-construction documents phase and back-check the review comments in the subsequent design submission.</p> <p>-Review contractor submittals for systems being</p>			<p><u>Man 4 (.6) - Building User Guide (E+:1): Create a simple guide covering information relevant to the tenant/occupants and non-technical building manager on the building's operation and performance.</u></p>																		

<p>commissioned. Verify compliance with the owner's project requirements and basis of design. Review must be concurrent with the review of the architect or engineer and submitted to the design team and owner.</p> <p>-Create systems manual.</p> <p>-Verify completion of training requirements for operators and occupants.</p> <p>-Review operation with O&M staff and occupants <10 months after substantial completion. Develop a plan for resolving outstanding commissioning-related issues.</p>	
<p><u>EA 4 (1) - Enhanced Refrigerant Management:</u> OPTION 1 No refrigerants.</p> <p>OR OPTION 2 Select refrigerants that minimize or eliminate emission of compounds that contribute to ozone depletion and global climate change.</p>	<p><u>Pol 3 (.71) - Refrigerant GWP - Cold storage:</u> Refrigerants within cold storage systems with a global warming potential (GWP) of <5.</p> <p><u>Pol 4 (.71-2.13) - No NOx emissions from heating source:</u></p> <p>1: Where the dry NOx emissions from delivered space heating energy are ≤ 100 mg/kWh (at 0% excess O₂).</p> <p>2: Dry NOx emissions from delivered space heating energy are ≤ 70 mg/kWh (at 0% excess O₂).</p> <p>3: Dry NOx emissions from delivered space heating energy are ≤ 40 mg/kWh (at 0% excess O₂) and emissions from delivered water heating energy are ≤ 100 mg/kWh (at 0% excess O₂).</p>
<p><u>EA 5 (2) - Measurement and Verification:</u> Develop/implement M&V plan consistent with Option D: Calibrated Simulation (Savings Estimation Method 2) <u>OR</u> Option B: Energy Conservation Measure Isolation, as specified in IPMVP Volume III. Cover 1+ year(s) of post-construction occupancy. Provide a corrective action process if results indicate energy savings are not being achieved.</p>	
<p><u>EA 6 (2) - Green Power:</u> Engage in 2+ year energy contract for 35%+ of the building's electricity with Green-e Energy products. Based on quantity consumed, not cost. Districts can purchase power centrally and allocate the power to specific projects.</p>	

Commercial buildings in the UK account for 25% of CO₂ emissions (Dept. of Communities and Local Government (Communities & Local Government), 2009) and buildings account for 50% of the country's energy consumption (Communities & Local Government, 2009). In the US, they use 73% of the country's electricity and account for 38% of CO₂ emissions (Department of Energy (DOE), 2008). In schools, HVACR accounts for 76% of energy consumption (DOE, 2008). Improving energy performance of buildings is an important step to reducing carbon emissions.

The main difference between the schemes is that BREEAM encourages reduction in consumption to a zero carbon level, whereas LEED's highest level of energy consumption reduction is 48%. A study between LEED and BREEAM found that BREEAM's carbon reduction credit is more demanding for projects to achieve than LEED's energy consumption credit (LEE & Burnett, 2007).

LEED provides credit to projects which develop and implement a measure and verification (M&V) plan covering 1+ years of post-construction occupancy. BREEAM does not have a M&V credit, as shown in Table 5, but requires all 'Outstanding' projects obtain an 'In-Use Certification' of performance within three years of operation to maintain the rating. If the project does not get an In-Use certification within that time period, it is downgraded to Excellent on the post-construction certificate. It benefits all projects to monitor their energy use post-occupancy, though the first year following construction may not provide an accurate picture of the buildings energy use because the building may not be fully occupied the entire time and adjustments may be taking place on the building's mechanical systems which effect its consumption (Gifford, 2008). Therefore, a longer M&V period monitoring the building after year one, like BREEAM's, may produce more accurate results.

Indoor Air Quality

Table 6 and the discussion that follows cover the issues of ventilation, VOCs in construction products used, and thermal comfort. Indoor air quality is critical in the design of schools because children breathe 50% more air per pound of body weight than adults. Inhaling fine particulate matter from idling vehicles has been associated with increased frequency of childhood illness according to the US Environmental Protection Agency (EPA, 2003).

Table 6 – Indoor Air Quality Comparison

LEED Schools version 3.0	BREEAM Education Issue 2.0
<p><u>IEQ PR 1 (0) - Minimum Indoor Air Quality</u> <u>Performance:</u> Meet Sections 4-7 of ASHRAE Standard 62.1-2007 (with errata but without addenda). AND</p> <p>CASE 1. Mechanically Ventilated Spaces: Design using the ventilation rate procedure or the applicable local code (most stringent).</p> <p>CASE 2. Naturally Ventilated Spaces: Follow ASHRAE Standard 62.1-2007, Paragraph 5.1 (with errata but without addenda).</p>	
<p><u>IEQ PR 2 (0) - Environmental Tobacco Smoke (ETS)</u> <u>Control:</u> Prohibit smoking indoors and <25' from</p>	

<p>entries, air intakes, operable windows and provide appropriate signage.</p>	
<p><u>IEQ 1 (1) - Outdoor Air Delivery Monitoring:</u> Install permanent ventilation monitoring systems to ensure design requirements are met. Must sound alarm when the airflow values or CO₂ levels vary by 10%+ from design values via a building automation system alarm.</p> <p>AND</p> <p>CASE 1. Mechanically Ventilated Spaces: Monitor CO₂ concentrations in spaces with a design occupant density of 25+ per 1,000 ft². CO₂ monitors must be between 3'- 6' AFF.</p> <p>Provide a direct outdoor airflow measurement device able to measure minimum outdoor air intake flow with an accuracy of ±15%, defined by ASHRAE 62.1-2007 (with errata but without addenda) where 20%+ of the design supply airflow serves non-densely occupied spaces.</p> <p>CASE 2. Naturally Ventilated Spaces: Monitor CO₂ within all naturally ventilated spaces. Monitors must be 3'-6' AFF.</p>	
<p><u>IEQ 2 (1) - Increased Ventilation:</u></p> <p>CASE 1. Mechanically Ventilated Spaces: Increase breathing zone outdoor air ventilation rates to occupied spaces by 30%+ above ASHRAE Standard 62.1-2007 (with errata but without addenda).</p> <p>CASE 2. Naturally Ventilated Spaces: Design natural ventilation systems for occupied spaces to meet the recommendations set forth in the CIBSE Applications Manual 10: 2005.</p> <p>AND</p> <p>OPTION 1: Use diagrams and calculations to show that the natural ventilation systems design meets the recommendations in CIBSE Applications Manual 10: 2005, CIBSE AM 13, or natural ventilation/mixed mode ventilation related sections of the CIBSE Guide B2.</p> <p>OR</p> <p>OPTION 2: Use a macroscopic, multizone, analytic model to predict room-by-room airflows will</p>	

<p>effectively naturally ventilate, defined as providing the minimum ventilation rates required by ASHRAE Standard 62.1-2007 Chapter 6 (with errata but without addenda1), for 90%+ of occupied spaces.</p>	
<p><u>IEQ 3.1 (1)- Construction Indoor Air Quality Management Plan—During Construction:</u> Develop/implement an IAQ plan for the construction and preoccupancy phases:</p> <ul style="list-style-type: none"> -During construction meet or exceed control measures of SMACNA IAQ Guidelines For Occupied Buildings Under Construction, 2nd Edition 2007 (Chapter 3). -Protect stored on-site and installed absorptive materials from moisture damage. -Permanently installed air handlers used during construction: Use MERV 8 filter at return air grilles, as determined by ASHRAE Standard 52.2-1999 (with errata but without addenda). Replace filtration media prior to occupancy. -Prohibit smoking inside the building and <25' from entrances once the building is enclosed. 	
<p><u>IEQ 3.2 (1) - Construction Indoor Air Quality Management Plan—Before Occupancy:</u> Develop/implement an IAQ plan after all finishes are installed and building has been cleaned.</p> <p>Compliance options:</p> <ul style="list-style-type: none"> -Pre-Occupancy Flush Out: supply air volume of 14,000 ft³ of outdoor air per ft² of floor area. Maintain internal temperature of 60°+ F and relative humidity ≤60%. -Post-Occupancy Flush-Out: The space may be occupied following delivery of 3,500 ft³+ of outdoor air per ft² of floor area. Post-occupancy: 0.30+ cfm per ft² of outside air or the design minimum outside air rate determined in IEQ Prerequisite 1, whichever is greater. -Air Testing: Conduct baseline IAQ testing, using protocols consistent with the EPA Compendium of Methods for the Determination of Air Pollutants in Indoor Air and as additionally detailed in the LEED Reference Guide, 2009 Edition. Contaminants for which a maximum concentration must not be 	

<p>exceeded include: Formaldehyde, Particulates, Total VOC, 4-Phenylcyclohexene, Carbon monoxide.</p>	
<p><u>IEQ 4 (1-4) - Low-Emitting Materials</u>: Choose from the following (4 maximum):</p> <ul style="list-style-type: none"> -Adhesives and Sealants (1 point) -Paints and Coatings (1 point) -Flooring Systems (1 point) -Composite Wood and Agrifiber Products (1 point) -Furniture and Furnishings (1 point) -Ceiling and Wall Systems (1 point) 	<p><u>Hea 9 (.88) - Volatile Organic Compounds</u>: Demonstrate emissions and substances from internal finishes and fittings comply with best practice levels:</p> <ul style="list-style-type: none"> -Wood panels -Timber structures -Wood Flooring -Resilient, textile and laminated floor coverings -Suspended ceiling tiles -Flooring adhesives -Wall-coverings -Adhesives for hanging-flexible wall-coverings -Decorative paints and varnishes
<p><u>IEQ 5 (1) - Indoor Chemical and Pollutant Source Control</u>: Minimize/control the entry of pollutants into the building and cross-contamination through:</p> <ul style="list-style-type: none"> -Permanent entryway system 10'+ at exterior entrances. -Sufficiently exhaust each space where hazardous gases or chemicals may be present or used to create negative pressure with respect to adjacent spaces when room doors are closed. -Mechanically ventilated buildings: install new air filtration media in regularly occupied areas prior to occupancy: MERV 13+ for both return and outside air that is delivered as supply air. -Provide containment for disposal of hazardous liquid wastes in places where water and chemical concentrate mixing. 	<p><u>Hea 8 (.88) - Indoor air quality</u>: Avoid sources of external pollution and recirculation of exhaust air in air intake by:</p> <ul style="list-style-type: none"> -AC/mixed-mode buildings: Air intakes and exhausts are over 10m (33') AND intakes are over 20m (66') from <i>sources of external pollution</i>. -Naturally-ventilated buildings: Operable windows/ventilators are 10m+ from <i>sources of external pollution</i>. <p>Provide fresh air and minimize internal pollutants (and ingress of external polluted air into the building) according to Building Bulletin 101 <i>Ventilation of School Buildings</i>.</p>
<p><u>IEQ 6.2 (1) - Controllability of Systems - Thermal Comfort</u>: Provide individual comfort controls for 50%+ of occupant workspaces. Operable windows may be used instead of controls for occupants located 20' inside and 10' to either side of the operable window. Operable window areas must meet ASHRAE Standard 62.1-2007 paragraph 5.1 Natural</p>	<p><u>Hea 7 (.88) - Potential for natural ventilation</u>: Demonstrate that fresh air is capable of being delivered to the occupied building spaces via a natural ventilation strategy, with sufficient user-controlled fresh air supply.</p>

<p>Ventilation (with errata but without addenda) requirements.</p> <p>Provide comfort system controls for shared multi-occupant spaces to enable adjustments that meet group needs. Comply with ASHRAE Standard 55-2004 (with errata but without addenda) and include the primary factors of air temperature, radiant temperature, air speed and humidity.</p>	<p><u>Hea 11 (.88) - Thermal zoning</u>: For providing local occupant control is available for temperature adjustment in each <i>occupied space</i> to reflect differing user demands.</p>
<p><u>IEQ 7.1 (1) - Thermal Comfort—Design</u>: Design HVAC systems and building envelope to meet ASHRAE Standard 55-2004. Demonstrate design compliance in accordance with the Section 6.1.1 documentation.</p>	<p><u>Hea 10 (.88) - Thermal comfort</u>: Assess thermal comfort levels in occupied spaces at the design stage to evaluate appropriate servicing options, ensuring appropriate thermal comfort levels are achieved.</p>
<p><u>IEQ 7.2 (1) - Thermal Comfort—Verification</u>: Conduct thermal comfort survey of building occupants (adults and students in grades 6+) 6-18 months post-occupancy in accordance with ASHRAE Standard 55-2004 (with errata but without addenda), via anonymous responses about thermal comfort in the building, including an assessment of overall satisfaction with thermal performance and identification of thermal comfort problems. Develop a correction plan if results indicate 20%+ of occupants are dissatisfied.</p>	
<p><u>IEQ 10 (1) - Mold Prevention</u>: Achieve: IEQ 3.1, IEQ 7.1, IEQ 7.2. HVAC systems and controls are designed to limit space relative humidity to $\leq 60\%$ during all load conditions. Develop and implement an IAQ program for buildings based on the EPA document, Building Air Quality: A Guide for Building Owners and Facility Managers.</p>	
	<p><u>Hea 17 (.88) - Specification of Laboratory Fume Cupboards</u>: Design fume cupboards and microbiological safety cabinets in accordance with the appropriate British Standard.</p>

LEED's PR 1, which is compulsory, requires 13-15 cfm/person (ASHRAE, 2007) for classrooms depending on the age of the students, while BREEAM requires 3-5 l/s per person (3.36-10.6 cfm/person) (Department for Children Schools and Families, 2006). BREEAM's rate is considerably lower than the Asthma Regional Council of New England recommendations of 20 cfm/person (Parker, 2005). LEED is consistent with the

Collaborative for High Performance Schools² (CHPS) requirement of 15 cfm/person, though they encourage 20 cfm/person (2006).

BREEAM addresses air intake locations, and window openings in naturally ventilated buildings to ensure they are not located near external air pollution sources, which LEED does not address. This is a strategy CHPS recommends in their transportation standard SP3 (2006). These distances are regardless of the type or MERV air filter value as BREEAM does not consider filters to provide adequate protection from sources of external pollution.

Both BREEAM and LEED address thermal comfort via design, as illustrated in Table 6, but only LEED addresses verification. While not compulsory, IEQ 7.2 requires an anonymous survey of building occupants (adults and students grades 6+) within 6-18 months after occupancy to determine what percentage of occupants are satisfied with thermal comfort systems of the building and requires a corrective action plan if 20%+ of occupants are dissatisfied.

With 1-13 (7.7%) students affected by asthma, mold prevention is essential to reducing absenteeism (EPA, 2005). LEED's IEQ 10 addresses mold prevention by requiring humidity levels of ≤60% post-occupancy and that projects meet three other IEQ credits, including pre-occupancy flush-out and thermal comfort credits. IEQ prior pre-occupancy and mold prevention are not addressed directly by BREEAM.

Materials & Resources

Table 7 and the discussion that follows cover the issues of construction waste management, sustainable and low VOC materials, reuse or salvaging of building elements, and sustainable timber harvesting.

Table 7 – Materials & Resources Comparison

LEED Schools version 3.0	BREEAM Education Issue 2.0
<p><u>MR PR 1 (0) - Storage and Collection of Recyclables:</u> Provide an easily-accessible dedicated area for the storage of recycling, including: paper, corrugated cardboard, glass, plastics and metals.</p>	<p><u>Wst 3 (.63-1.89) - Recycled waste storage:</u> provide a central, dedicated space for the storage of recyclables.</p> <p>Two points: for creating policies/procedures which:</p> <ul style="list-style-type: none"> a. Include procedures for collection and recycling of consumables b. Are endorsed at the school governor level c. Will be operational at a local level
<p><u>MR 1.1 (1-2) - Building Reuse – Maintain Existing Walls, Floors and Roof:</u> Reuse existing building structure and envelope (excluding windows and nonstructural roofing material). 75%+ 1 point, 95%+</p>	<p><u>Mat 3 (.83) - Reuse of building façade:</u> 50% of the total final façade (by area) in situ and at least 80% of the reused façade (by mass) comprises in-situ</p>

² The Collaboration for High Performance Schools (CHPS) is an organization formed in 1999 which specifically addresses environmentally conscious school environments. In 2002 CHPS created the first building rating system for K-12 schools. The organization now has a six volume best practices manual covering a variety of issues related to the design and operation of high performance schools with six, state-specific manuals: CA-CHPS, WA-CHPS, TX-CHPS, CO-CHPS, NY-CHPS and MA-CHPS (CHPS, 2009).

<p>2 points.</p>	<p>reused material.</p> <p><u>Mat 4 (.83) - Reuse of building structure:</u> Reuse 80%+ of existing primary structure and, for part refurbishment/part new build, the volume of the reused structure comprises 50%+ of the final structure's volume.</p>
<p><u>MR 1.2 (1) - Building Reuse—Maintain Existing Interior Nonstructural Elements:</u> Reuse interior nonstructural elements in 50%+ (area) of the completed building including additions.</p>	
<p><u>MR 2 (1-2) - Construction Waste Management:</u> Recycle and/or salvage nonhazardous construction and demolition debris. Calculated by weight or volume (must be consistent). 50%+ 1 point, 75%+ 2 points.</p>	<p><u>Wst 1 (.63-1.89) - Construction Site Waste Management:</u> Non-hazardous construction waste (m³/100m² or tonnes/100m²) generated on site is equal or better than good or best practice levels.</p> <p>Two points: Significant majority of nonhazardous construction waste generated is diverted from landfill and reused or recycled.</p>
<p><u>MR 3 (1-2) - Materials Reuse:</u> Salvaged, refurbished or reused materials, for 5%+ or 10%+ (based on cost), of the total value of project materials.</p>	<p><u>Wst 2 (.63) - Recycled aggregates:</u> Significant use of recycled or secondary aggregates in 'high-grade' building aggregate uses.</p>
<p><u>MR 4 (1-2) - Recycled Content:</u> Materials with recycled content such that the sum of postconsumer recycled content plus 1/2 of the pre-consumer content constitutes 10%+ or 20%+, based on cost, of the total value of the project's materials.</p>	<p><u>Mat 1 (.83-4.98) - Materials specification (major building elements):</u> Determined by the BRE <i>Green Guide to Specification</i> ratings for the major building/finishing elements.</p> <p><u>Mat 2 (.83) - Hard landscaping and boundary protection:</u> 80%+ of external hard landscaping and boundary protection area specifications earn a BRE <i>Green Guide to Specification</i> rating A or A+.</p>
<p><u>MR 5 (1-2) - Regional Materials:</u> Materials or products extracted, harvested or recovered, and manufactured, ≤500 miles of the project site for 10%+ or 20%+, of the total materials value.</p>	
<p><u>MR 6 (1) - Rapidly Renewable Materials:</u> Rapidly renewable material made from plants harvested within a ≤10-year for 2.5% of the total value of all building materials and products used in the project.</p>	<p><u>Mat 5 (.83-2.49) - Responsible sourcing of materials:</u> 80% of the assessed materials in the following elements are responsibly sourced:</p> <ul style="list-style-type: none"> -Structural Frame -Ground floor -Upper floors (including separating floors) -Roof

	<ul style="list-style-type: none"> - External and internal walls -Foundation/substructure -Staircase <p>100% of timber must be legally sourced.</p> <p><u>Mat 6 (.83-1.67) - Insulation:</u> Thermal insulation products with low embodied impact relative to their thermal properties, determined by the BRE <i>Green Guide to Specification</i> ratings. 2 Points: Responsibly sourced thermal insulation products.</p>
<p><u>MR 7 (1) - Certified Wood:</u> 50%+ (cost) for FSC certified wood-based materials/products. Components include (minimum), structural framing and general dimensional framing, flooring, sub-flooring, wood doors and finishes.</p>	<p>*see Mat 5 and Man 3</p>
	<p><u>Man 3 (.83-2.49) - Construction Site Impacts:</u> One point 2+ items. Two points: 4+ items. Three points: 6+ items.</p> <ul style="list-style-type: none"> -Monitor, report and set targets for CO₂ or energy arising from site activities -Monitor, report and set targets for CO₂ or energy arising from transport to and from site -Monitor, report and set targets for water consumption arising from site activities -Implement best practice policies in respect of air (dust) pollution arising from the site -Implement best practice policies in respect of water (ground and surface) pollution occurring on the site -Main contractor has an environmental materials policy, used for sourcing of construction materials to be utilized on site -Main contractor operates an Environmental Management System. <p>One point for demonstrating that 80%+ of site timber is responsibly sourced and 100% is legally sourced.</p>

Both LEED and BREEAM place emphasis on the reuse of elements in an existing building during a major renovation. The big difference between the two is that BREEAM does not award credit for reusing interior elements and that LEED encourages reuse of materials for much larger additions than BREEAM.

BRE produces two guides, the Green Book, and Green Guide to Specification, which provide valuable information for designers. These tools allow a quick sustainability comparison for specification options and a Life Cycle Analysis of building products. LEED does not produce a product guide. For a designer seeking to earn credits MR 4-7, designers must find products which meet the credit criteria either through manufacturers or by looking to the organizations that evaluate products for their environmental and health claims such as the Forest Stewardship Council, Green Seal, etc.

BREEAM’s Man 3 awards credits to projects where contractors have a sustainable materials sourcing policy, use legally harvested timber and monitor their CO₂ offsets on the construction site. Contractors must also set targets and record their water consumption, monitor dust arising at the site, and take care to minimize pollution of ground and surface water sources. The objectives of this credit is commendable, however it fails to set strict targets (except requiring 80% of timber be reclaimed, reused or responsibly sourced). While a contractor can track this information there is no incentive to do more, which is a weakness of the credit.

Lighting, Daylighting and Views

Table 8 and the discussion that follows cover the issues of daylighting and glare control, lighting, light pollution and occupant views to the building’s exterior.

Table 8 – Lighting, Daylighting and Views Comparison

LEED Schools version 3.0	BREEAM Education Issue 2.0
<p>IEQ 6.1 (1) - <u>Controllability of lighting systems</u>: 90%+ of regularly occupied spaces have individual lighting controls. Classrooms have 2+ operational modes: general and A/V.</p>	<p><u>Hea 6 (.88)- Lighting zones and controls</u>: Appropriately zoned and occupant controllable lighting with the option for commonly required lighting settings to be selected quickly and easily.</p> <p><u>Health credit 4 (.88) - High frequency lighting</u>: Install high frequency ballasts on fluorescent and compact fluorescent lamps.</p>
	<p><u>Hea 5 (.88) - Internal and external lighting levels</u>: Internal and external lighting, where relevant, is specified according luminance levels (in lux) recommended by CIBSE and internal luminance levels outlined in Building Bulletin 90.</p>
<p>IEQ 8.1 (1-3) - <u>Daylight and Views—Daylight</u>: Use 1 of 4 options; computer simulation, prescriptive, measurement, or a combination to achieve daylighting of:</p> <p>Classroom Spaces Points</p>	<p><u>Hea 1 (.88) - Daylighting</u>: 80%+ of floor area in each space is adequately daylit with an average daylight factor of 2%+.</p> <p>PLUS either (b) OR (c AND d):</p> <p>b. A uniformity ratio of at least 0.4 or a minimum point daylight factor of 0.8%+ (spaces with glazed</p>

<p>75% 1</p> <p>90% 2</p> <p>Daylighting levels are ≥ 25 fc but not > 500 fc in clear sky conditions.</p> <p>Provide glare control devices.</p>	<p>roofs, such as atria, must achieve a uniformity ratio of 0.7+ or a minimum point daylight factor of 1.4%+).</p> <p>c+d. A view of sky from desk height is achieved and the room depth criterion $d/w + d/HW < 2/(1-RB)$ is satisfied.</p> <p><u>Hea 3 (.88) - Glare control:</u> Provide an occupant-controlled shading system in relevant areas.</p>
<p><u>IEQ 8.2 (1) - Daylight and Views—Views:</u> Achieve a direct line of sight to the exterior between 30”-7’6” AFF for occupants in 90% of regularly occupied areas.</p>	<p><u>Hea 2 (.88) - View out:</u> Where <i>relevant building areas</i> have an <i>adequate view out</i>. Defined as within 7m (23’) of a wall with a window or permanent opening providing an adequate view out, where the window is $\geq 20\%$ of the total inside wall area.</p>
<p><u>SS 8 (1) - Light Pollution Reduction:</u></p> <p>Option 1: For interior lighting reduce input power (by automatic device) for nonemergency interior luminaries with a direct line of site to any translucent or transparent openings in the building envelope by 50% between 11 p.m. - 5 a.m.</p> <p>Option 2: Use automated shields over translucent or transparent openings with a direct line to non-emergency luminaries between 11 p.m. and 5 a.m. if transmittance is $< 10\%$.</p> <p>For exterior lights, only light areas as required for safety and comfort. Power densities must not exceed ANSI/ASHRAE/IESNA Standard 90.1-2007 (with errata but without addenda) for the classified zone. Meet exterior lighting control requirements from ANSI/ASHRAE/IESNA Standard 90.1-2007 (with errata but without addenda1), Exterior Lighting Section, without amendments. Classify the project under 1 of the following zones, as defined in IESNA RP-33, and follow all of the requirements for that zone.</p> <p>Physical education spaces are exempt from complying with the lighting power density requirements of this credit.</p>	<p><u>Pol 7 (.71) - Reduction of night light pollution:</u> External lighting designs that are in compliance with the Institution of Lighting Engineers (ILE) Guidance Notes for the reduction of obtrusive lighting, between 11:00 p.m. and 7:00 a.m. Can be achieved via timer or reducing lighting levels at or before 11:00 p.m.</p> <p><u>Ene 4 (.73) - External lighting:</u> Where energy-efficient external lighting is specified for all fittings and controlled for the presence of daylight.</p>

Proper design of lighting and daylighting systems is crucial to school design since much of the curricula of schools require visual tasks such as looking at a screen or blackboard, or reading and writing. While additional research is needed in this area, it is theorized that specifically for students and teachers who do

not have properly corrected vision, lighting levels are critical to their learning and teaching (National Research Council, 2007).

BREEAM addresses daylighting and glare control via separate credits unlike LEED which combines the two. This means that a BREEAM project can receive a credit for providing daylighting to 80%+ of its classrooms but not address glare control, creating problems for the users.

BREEAM addresses internal and external lighting levels via Hea 5. These are consistent with recommendations of the US National Research Council’s Green School report, which recommends that lighting levels standards be addressed by schemes such as LEED (National Research Council, 2007).

In addition to recommending internal lighting levels for LEED’s scheme, both LEED and BREEAM would both benefit from addressing the energy efficiency of luminaries and lamps, which could dramatically impact energy efficiency of the building project.

Projects receiving daylighting credits could benefit from adding sensors monitoring both occupancy and daylight levels. This stands to significantly impact energy usage, and ensure adequate light levels are maintained. According to the US Department of Energy, schools can save 8% - 20% of their lighting energy by turning off lights in unoccupied rooms (DOE, 2004).

Acoustics

Table 9 and the discussion that follows address the issue of acoustics in schools. Acoustics help make learning easier for students by providing them with quiet classrooms where they can clearly hear the lessons at hand, and reduce vocal fatigue for teachers (National Research Council, 2007).

Table 9 – Acoustics Comparison

LEED Schools version 3.0	BREEAM Education Issue 2.0
<p><u>IEQ PR 3 (0) - Minimum Acoustical Performance and IEQ 9 - Enhanced Acoustical Performance:</u> Maximum background noise level from HVAC systems in classrooms equals 45 dBA. The sound-absorptive finishes in these spaces must comply with reverberation time requirements of ANSI Standard S12.60-2002.</p> <p>100% of ceilings (or a combination of acoustic applications equal to the ceiling area) in classroom under 20,000 ft² must have a noise reduction coefficient of 0.70+. Classrooms 20,000+ ft³ must have a reverberation time of ≤1.5s per ANSI Standard S12.60-2002.</p>	<p><u>Hea Credit 13 (2.64) – Acoustic Performance:</u> For following Building Bulletin 93 and performing follow-up testing prior to occupancy to verify that the requirements have been met or are being remedied prior to occupancy.</p>
<p><u>IAQ 9 (1) – Enhanced Acoustical Performance:</u> Building shell and partitions must meet sound transmission class requirements of ANSI Standard S12.60-2002, except windows, which must meet an STC rating of ≥35 and to reduce background noise</p>	

level to ≤40 dBA from HVAC systems in classrooms.	
	<u>Pol 8 (.71) – Noise attenuation:</u> Address noise impact from the site will have on the surrounding neighborhood (800m radius). Assessed according to British Standard 4142:1997, by a qualified acoustician.

BREEAM and LEED both set a 35 dB standard for classrooms, where students spend the majority of their time. LEED however, also addresses noise generating from HVAC design, with criteria that meets the recommendations of the National Research Council’s Green School’s report (National Research Council, 2007). The major difference between the two is that LEED’s acoustical prerequisite impacting classrooms is compulsory, whereas BREEAM’s is not.

Neither BREEAM nor LEED address the impacts of locating a school in an area away from excessive noise from air, train or vehicular traffic, etc. while BREEAM does address noise pollution emanating from the school. The National Research Council’s Green School’s report recommended that future green school guidelines require that new schools be located away from areas of high outdoor noise (National Research Council, 2007).

Due to the importance of acoustics in school for the health and wellbeing of the students and teachers, making all of the acoustic credits compulsory is an important change that would benefit both schemes.

Transportation

Table 10 and the discussion that follows cover the issues of increasing public transportation use, encouraging walking and cycling, which reduces CO₂ emissions and encourages fitness (Cooper, Anderson, et al, 2005).

Table 10 – Transportation Comparison

LEED Schools version 3.0	BREEAM Education Issue 2.0
<p><u>SS 4.1 (4) - Alternative Transportation- Public Transportation Access:</u></p> <p>OPTION 1. Rail Station Proximity: Build ≤1/2-mile of an existing or planned/funded commuter rail, light rail or subway station.</p> <p>OPTION 2. Bus Stop Proximity: Build ≤1/4-mile of 1+ stop(s) for 2+ public, campus, or private bus lines usable by occupants. A school bus system counts as 1 line.</p> <p>OPTION 3. Pedestrian Access: Show the attendance boundary means 80%+ of students live ≤3/4 mile for grades 8-, and ≤1.5 mile for grades 9+. Allow pedestrian access to the site from all residential</p>	<p><u>Tra 1 (2.64) - Provision for Public Transport:</u> Sliding scale based on the buildings’ accessibility to the public transport network measured by the Accessibility Index (AI) which measures:</p> <ul style="list-style-type: none"> - The distance (m) from the <i>main building entrance</i> to each <i>compliant public transport node</i> - The public transport type e.g. bus or rail - The <i>average number of services</i> stopping per hour at each <i>compliant node</i> during the standard <i>operating hours</i> of the building for a <i>typical day</i> <p>-One credit for a school bus system.</p>

<p>neighborhoods that house the planned student population.</p> <p>ALL OPTIONS: Provide dedicated walking or biking lanes to transit lines that extend from the building at least to the end of the property in 2+ directions without any barriers.</p>	
<p><u>SS 4.2 (1) - Alternative Transportation-Bicycle Storage and Changing Rooms</u>: Storage for 5% of students and staff grades 4+ and changing facilities for .5% of staff. Bike lanes must extend 2 directions from the property.</p>	<p><u>Tra 3 (.88-1.78)- Cyclist Facilities</u>: 5+ storage spaces for each class in any one year group for primary schools and between 5%-10% of users in secondary schools depending on the school’s capacity. Point 2: Provide changing rooms.</p> <p><u>Tra 4 (.88) - Pedestrian and cyclist safety</u>: Design site layout in accordance with best practice to ensure safe and adequate pedestrian and cycle access.</p>
<p><u>SS 4.3 (2) - Alternative Transportation – Low-Emitting and Fuel-Efficient Vehicles</u>: Provide preferred parking to Low-Emitting and Fuel-Efficient vehicles or provide 20% (percent by vehicles, fuel, or both) fuel-efficient or low-emitting busses for students.</p> <p><u>SS 4.4 (2) - “Alternative Transportation – Parking Capacity”</u>: Addresses parking capacity of the site.</p>	<p><u>Tra 5 (.88) - Travel Plan</u>: Develop a travel plan strategy for managing travel/transport within the school. Must contain physical and behavioral measures to increase travel choices and reduce reliance on single-occupancy car travel.</p> <p><u>Tra 8 (.88) - Deliveries and Maneuvering</u>: Design vehicle access areas to ensure adequate space for maneuvering delivery vehicles and provide space away from maneuvering area for garbage bins and pallets.</p>

BREEAM’s public transport credit’s sliding scale, based on accessibility, this makes the credit more rigorous than LEED’s. LEED’s credit fails to take into account the route of the transport service, hours of service, and frequency of service; important characteristics that influence how often users of the building may use the stop.

BREEAM also places greater emphasis on cycling than LEED at a primary school level. BREEAM requires 5 cycle storage places per primary school class (grade level) while LEED requires spaces serving 5% of students and staff above third grades. For a class smaller than 80 students this means BREEAM requires more spaces.

BREEAM addresses the importance of creating and maintaining programs which encourage use of these alternative transport options, which seems vital to their success in its credit Tra 5. Otherwise, a project may have close access to public transportation nodes, cyclist storage and changing rooms without users. LEED would benefit from establishing such a credit.

Innovation & Education

This section addresses credits for exemplary performance and innovative sustainable designs.

LEED has an “Innovation in Design” section while BREEAM’s innovation and exemplary credits do not have a special category, and are totaled at the end of the evaluation, un-weighted. Both LEED and BREEAM provide prescriptive requirements for exemplary performance such as providing 95% FSC certified lumber under Mat 8 in LEED, when the requirement for Mat 8 is 50% FSC Certified lumber. LEED has a maximum of four innovation and exemplary credits which are tallied under Innovation In Design Credits 1.1-1.4. BREEAM has nine credits which outline exemplary performance guidelines, an additional fee is charged when a project attempts to achieve an Innovation credit application in BREEAM.

In addition to innovation and design, LEED provides projects a point in Innovation 2 “LEED AP” for having a LEED Accredited Professional on the design team.

Both LEED and BREEAM provide credits for using the school building as a teaching tool. LEED provides this credit under Innovation 3 “The school as a teaching tool” and BREEAM provides points for the publication of information about the building’s systems and its performance in a detailed case study format under Management 9 “Publication of Building Information” and under Management 10 “Development as a Learning Resource.”

Conclusions

There are several key differences between BREEAM Education and LEED Schools identified in this study. Each scheme has strengths and weaknesses. By looking towards the other for ideas, both schemes stand to benefit in increasing the rigor of their schemes to ensure that students, teachers and school districts get the best value for their money.

Strengths of BREEAM

-Tiered Prerequisites: BREEAM’s tiered prerequisite system, which changes based on the level of certification a project is aiming to achieve (very good, excellent, etc.), allows scheme administrators the ability to set key priorities of sustainable design in schools. The tiers ensure a project receiving an ‘excellent’ or ‘outstanding’ rating use credits that have the most impact on the building’s sustainability.

-Accountability: In addition to earning a score and meeting the necessary prerequisites an ‘outstanding’ building must obtain a BREEAM In Use Certification of Performance within three years of operation (with regular reviews in accordance with that scheme) in order to maintain its rating. Projects that fail this final step are downgraded to ‘excellent.’ This requirement is good for all: it demands accountability which protects the owner of the project and ensures the building is operating as promised. It also provides BREEAM with valuable information about its best projects and how they are functioning post-occupancy. ‘Excellent’ buildings must also submit information for a case study on the buildings, or risk being downgraded. This information also serves to help researchers understand how these buildings are performing and identify potential weaknesses in the scheme.

-Metering: Metering of electrical uses and water consumption are important features which enable monitoring post-construction in order to identify problems, and monitor energy consumption over time. LEED would benefit from requiring sub-metering of substantial electrical equipment and meters for water efficiency and BREEAM would benefit from making it compulsory for all tiers.

-Life Cycle Analysis (LCA): BRE’s Green Guide to Specification and Green Book Live offer designers and specification writers and designers a side-by-side comparison of the environmental impact of their specifications. These tools also allow quick comparison of products, unlike LEED which requires designers

to find information themselves. These guides make identifying, specifying and selecting environmentally friendly products easy for designers and means that projects may be more likely to achieve credits related to these guides.

-Transport: While both schemes encourage various forms of alternative transport through their credits, BREEAM's Transport credit 5 - Travel Plan, provides a point for projects that develop a travel plan strategy for managing travel and transport within a school containing both physical and behavioral measures to combat single-occupancy car travel. Without developing and enacting such a plan the design features which were credited may go unused or underused.

Strengths of LEED

-Training: A well-designed building may not operate to its highest efficiency if proper commissioning and training are not completed. LEED requires training of key maintenance personnel via EA 3 which is imperative to ensuring that the building operates efficiently and as it was designed.

-Utility Monitoring and Use: LEED requires projects to share whole-building energy and water use data with the USGBC for a period of five years post-occupancy (USGBC, 2009). This will enable LEED to analyze how these buildings are performing compared to their projected energy use and to non-certified buildings. In order to enhance the integrity of EA 1, Wat PR 1 and Wat 3, which are based on energy modeling tools, follow-through to measure the actual energy use after one year of occupancy would enable LEED to hold designers accountable for their efficiency claims and help ensure projects which are not performing as designed do not have higher ratings than they deserve.

-Clear Thresholds: In setting thresholds for project to meet in the areas of energy, water consumption, and materials LEED provides projects with tangible goals for designers to achieve. BREEAM, provides credits in areas for reducing potable water in landscaping, for example, but does not set a clear threshold which defines the amount of reduction needed to qualify for the points. LEED, conversely, demands a minimum potable water reduction of 50%.

-Lighting and Daylighting: LEED addresses daylighting and glare control in one credit, ensuring that projects do not have substantial daylighting schemes without addressing glare issues. BREEAM does not, and should combine its daylighting and glare control credits to ensure schools are not designed with extensive daylighting features but without glare control devices.

LEED should specify the minimum lighting levels needed in school spaces to ensure that students are getting enough light in the classroom for the tasks they are completing.

-Indoor Air Quality: LEED offers credits which cover IAQ during construction and pre-occupancy, an area BREEAM does not cover. These credits help protect the building from mold and mildew growth and ensure IAQ levels are satisfactory upon occupancy.

-Heat Island Effect: LEED addresses the heat island effect via two credits. BREEAM's lack of credits tackling the heat island effect is a serious omission which impacts both the health of occupants and energy consumption and should be corrected.

Room for improvement

Both schemes could benefit from developing a specific scheme which addresses ongoing operation in areas such as pesticide use, pest control, waste management and housekeeping as they relate to schools. These topics addressed by other sustainable schools programs, such as the American Collaborative for High Performance Schools group via their Maintenance and Operations Manual (CHPS, 2004).

Neither BREEAM nor LEED address lamp and luminaries efficiency from an energy efficiency perspective. Providing credit for the installation of combined daylighting/occupant sensors would also help reduce energy costs and ensure adequate lighting levels are maintained.

Educating the community at large about the schemes and sustainability in general is critical to these schemes' success. It is not enough that the public has heard of LEED and BREEAM but that they recognize the different levels or rigor a project must undergo to achieve certification. Project owners and stakeholders must understand the risk of just ticking boxes to achieve a score and understand the importance of undertaking a whole-building approach on sustainability. One method projects can utilize to help educate the public is their websites by listing key information about their building such as: envelope performance, energy consumption, responsible material sourcing, and sustainable design techniques accompanied by graphics which help convey these concepts to a wider audience. In order to advance the cause of both LEED and BREEAM by making increasing awareness of green buildings laypeople must be able to recognize a building's 'green' features, and understand how the features work together to create a sustainable project.

Schools are an excellent place to focus on sustainability due to educational mission and because everyone in society has contact with schools at various stages in their life. The building can become a teaching example of sustainable design with graduates serving as ambassadors and champions of sustainable design or leaving with ideas for their refinement. This generation will prove critical to developing further technologies and solutions to curb reliance on fossil fuels and other natural resources.

As additional schools are certified under these schemes additional research should be completed to determine the added costs associated with certifying projects as well as the performance of these schools post-construction.

References

Acoustical Society of America (2002). American National Standard Acoustical Performance Criteria, Design Requirements, and Guidelines for Schools, 5, 7.

Alter, L. (2008, February). Design and Architecture. Slate on “Decidedly Dupable” LEED.

ASHRAE (2007). Ventilation for Acceptable Indoor Air Quality: Standard 62.1-2007. Atlanta, Georgia, 13.

Author Unknown (2006). Assessing the Assessor: BREEAM vs. LEED. Sustainability Magazine, volume 9, 30-33.

BRE Global (2009). The Green Guide to Specification: Green Guide 2008 Ratings.

<http://www.thegreenguide.org.uk/ggelement.jsp?buildingType=Schools&category=31&parent=0&elementT=10150> (July 12, 2009).

BREEAM International (2008, November). What is BREEAM? Frequently Asked Questions.

British Research Establishment Global (2008, August). BRE Environmental & Sustainability Standard: BES 5051: ISSUE 2.0. BREEAM Education 2008 Assessors Manual, 2-396.

British Research Establishment (2009). Green Guide. The Environmental Profiles Methodology 2008.

<http://www.thegreenguide.org.uk/page.jsp?id=55> (July 12, 2009).

British Research Establishment (2009). Green Book Live: Energy Saving Recommended Products: Glazing.

<http://www.greenbooklive.com/search/displaycompany.jsp?partid=10012§ionid=10028&companyid=114019> (July 12, 2009).

Building Research Establishment (2009). School Design, Getting it Done Right with BRE.

<http://www.bre.co.uk/page.jsp?id=1037> (May 25, 2009).

British Research Establishment (2006, March). *Ventilation and Indoor Air Quality in Schools – Guidance Report 20282533*.

<http://www.communities.gov.uk/documents/planningandbuilding/pdf/144155.pdf> (July 19, 2009).

BSRIA (2009). BREEAM or LEED Strengths and Weaknesses of the two Main Environmental Assessment Methods. www.bsria.co.uk/news/breeam-or-lead/ (August 1, 2009).

Buttler, M. & C. Stoy (2009). Universitat Stuttgart – Germany. ERES Conference. Comparing the Benefit of International Assessment Methods.

Collaborative for High Performance Schools (2009). About. <http://www.chps.net/dev/Drupal/node/133> (September 8, 2009).

Collaborative for High Performance School (2006). Best Practices Design Manual 2006, Volume II, 6, 68.

Collaborative for High Performance Schools (2004). Maintenance and Operations Manual, Volume IV.

Cooper, A., L. Anderson, N. Wedderkopp, A. Page, K. Froberg (2005). *American Journal of Preventive Medicine, Volume 29, Issue 3, October 2005, Pages 179-184*. Physical Activity Levels of Children Who Walk, Cycle, or Are Driven to School.

Crawley, D. & Ilari Aho (1999). Building environmental assessment methods: applications *and* development trends. *Building Research & Information*; Jul99, Vol. 27 Issue 4/5, p300-308.

Department for Children, Schools and Families (2006, July). Building Bulletin 101: Ventilation of School Buildings: Version 1.4, 6-7, 22.

Department for Education and Skills (2003). Building Bulletin 93: Acoustic Design of Schools, 9.

Department for Children Schools and Families (2006). Schools for the Future, Design of Sustainable Schools: Case Studies.

Department for Communities and Local Government (2008). Energy Performance Certificates (EPCs) and Non-dwellings: A guide for building owners, landlords and tenants.

Department of Communities and Local Government (2009). Energy Performance Certificate (public and commercial buildings)
www.communities.gov.uk/planningandbuilding/theenvironment/energyperformance/publiccommercialbuildings/energyperformancecertificates/ (August 1, 2009).

Department of Communities and Local Government (2009). Other Buildings.
www.communities.gov.uk/planningandbuilding/theenvironment/energyperformance/publiccommercialbuildings/ (August 1, 2009).

Department for Education and Employment (1999). Building Bulletin 90: Lighting Design for Schools, 23.

Department of Education Skills and Families (2007). Schools for the Future, the Cost of BREEAM Compliance in Schools, 34, 40.

Energy & Resource Solutions (2005, January). Northeast Collaborative for High Performance Schools Protocol Version 1.1, 13, 25, 36.

Environment Agency (2008). Areas of water stress: final classification, 5. <http://publications.environment-agency.gov.uk/pdf/GEHO1207BNOC-e-e.pdf> (August 22, 2009).

Faber, M. (2009). AECOM. "BREEAM Frequently Asked Questions."
<http://www.fabermaunsell.com/MarketsAndServices/48/61/index.html> (July 10, 2009).

Department of Education Skills and Families (date unknown). Schools for the Future, the Cost of BREEAM Compliance in Schools, 34, 40.

Gifford, H. (2008). A Better Way to Rate Green Buildings. www.henrygifford.com.

Gomez, S. (date unknown). *CB Richard Ellis, Ltd.* Is the Client Willing to Pay to Occupy a Greener Building?

Greater London Authority (October 2006). London's Urban Heat Island: A Summary for Decision Makers, 7.

Green Building Magazine (August 2009). LEED and BREEAM, How do they Compare?
<http://www.ukgbc.co.uk/leed.php> (August 1, 2009).

Happio, A. and P. Viitaniemi (2008). Environmental Assessment Impact Review. Volume 28, Issues 7, October 2008. A Critical Review of Building Environmental Assessment Methods, 469-482.

Harputlugil, G., Hensen, J. (2006). The Relation Between Building Assessment Systems and Building Performance Simulation, http://www.bwk.tue.nl/bps/hensen/publications/06_iprc_ulukavak.pdf (August 23, 2009).

Howard, N. (2005). Building Environmental Assessment Methods: In Practice. 2005 World Sustainable Building Conference, Tokyo.

Informed Building (February 2008). LEED Not Without Criticism.
<http://www.informedbuilding.com/Informed-Concepts/Main6/LEED-Not-Without-Criticism/> (July 11, 2009).

Kats, G. (2006). Capital E Report. Greening America's Schools, Costs and Benefits, 4, 20.

Lee, W.L and J. Burnett. Building and Environment. Benchmarking energy use assessment of HK-BEAM, BREEAM, and LEED. Volume 43, Issue 11, November 2008, 1882-1891.

National Research Council (2007). Green Schools: Attributes for Health and Learning, 21, 82, 88-89, 99-100, 103-104.

National Forum on Education Statistics (2003). School Facilities Maintenance Task Force. Planning Guide for Maintaining School Facilities, 15.

Parker, J. (2005, March). Asthma Regional Council of New England. Reducing Asthma Triggers in Schools: Recommendations for Effective Policies, Regulations, and Legislation.

Postel, S. (2000). Entering An Era of Water Scarcity: The Challenges Ahead. Ecological Applications: Vol. 10, No. 4, pp. 941-948.

Santosa, E. (2007). PennDesign, University of Pennsylvania. LEED, a real "green" building guide, 22.

Salvesen, D., A. Sachs & K. Engelbrecht (2006). Intergovernmental Collaboration and School Siting, 9.

Scheuer, C., W. Scheuer & G. Keoleian (2002). National Institute of Standards and Technology. Evaluation of LEED Using Life Cycle Assessment Methods, 16.

Schendler, A., & R. Udall (2005, June 23). LEED is broken-Let's Fix It. Grist Magazine.
<http://www.grist.org/article/leed>. (July 11, 2009).

U.S. Department of Education (2006-07), National Center for Education Statistics, Common Core of Data (CCD), Public Elementary/Secondary School Universe Survey, Version 1a.

U.S. General Accounting Office (1995), School Facilities: Condition of America's Schools, (GAO/HEHS-95-61), 9.

U.S. Green Building Council (2009). LEED 2009 for Schools: New Construction and Major Renovations. May 2009, Vi-87. <http://www.usgbc.org/ShowFile.aspx?DocumentID=5547> (June 10, 2009).

U.S. Green Building Council (2008). LEED Initiatives in Governments and Schools, <http://www.usgbc.org/DisplayPage.aspx?CMSPageID=1852#K-12> (May 25, 2009).

U.S. Green Building Council (2009). LEED Rating Systems, <http://www.usgbc.org/DisplayPage.aspx?CMSPageID=222> (May 25, 2009).

U.S. Department of Energy (2009). 2008 Buildings Energy Data Book, 3-32.

U.S. Department of Energy (2004). School Operations and Maintenance: Best Practices for Controlling Energy Costs, 51.

U.S. Environmental Protection Agency (2003). Air Pollution and Kids: What you Should Know About Diesel Exhaust and School Bus Idling, 1.

U.S. Environmental Protection Agency (2005). IEQ Tools For Schools: Managing Asthma in the School Environment, 3.

Wargo, J. (2002). Environment and Human Health, Inc. Children's Exposure to Diesel Exhaust on School Buses, 5.

CHAPTER II

RETHINKING REICHE

Part II of this project seeks to utilize the research completed in Part I to generate sustainable design strategies in developing a plan to renovate the Howard C. Reiche Community School in Portland, Maine.

The City of Portland Maine and the Portland Public School District

The city of Portland, Maine's largest city, has a population of 63,011 with 18.8% of the population under 18 years of age, according to the 2000 Census. Portland, borders the Casco Bay to the South and the Fore river to the West and is considered the financial, business and retail capital of this rural New England state (City of Portland, 2009). Temperatures in the city are moderated by its location on the coast with cold and snowy winters and sunny and mild summers.

Accolades received by the city in 2009 include, ranking as Forbes Magazines' #1 Most Livable Cities (Greenburg, 2009) and its listing as one of Relocate-America's Top-100 Places to Live (2009). In the Fall of 2008 Portland was touted by National Geographic as the 41st most historic destinations in the world (Walljasper, 2008) and the American Planning Association named Portland's Commercial Street one of the Top 10 Great Streets in America (2009).

The city's median household size is 2.08 and the median household income for the city is \$36,650. 14.1% of the population is below the poverty line and 9.9% of the households speak a language other than English at home (U.S. Census, 2000).

The city has four public high schools, three middle schools and ten public elementary schools, with schools located on the city's islands in the Casco Bay and in suburban and urban settings. These schools educate approximately 7,000 of Portland's students (Portland Public Schools, 2008) in grades K-12.

Since Portland was designated a refugee resettlement city in 1980, over 10,000 political refugees have come to the state, the majority of which have stayed in Portland. These refugees come from countries including: Somalia, Sudan, Morocco, Rwanda, Ethiopia, Congo, Eritrea, Togo, Colombia, Greece, Russia, Peru, Honduras, Cambodia, Bosnia, Iran, Iraq, and Kazakhstan (Farish, 2003). Portland, Maine also has the largest Sudanese population in the United States with over 2,000 refugees having arrived in the city over the past decade (Scott, 2006 and WMTV8, 2009). The Portland Public School system is both culturally and ethnically diverse. Approximately 25% of the Portland School enrollment is made up of students from homes that speak a language other than English, and 1,400 of them are considered English Language Learners (ELL) (Portland Public Schools, 2009). In order to better serve this diverse population, the Portland Public School system has a special Multilingual and Multi-Cultural Center to provide support to refugees and their children with English language acquisition.

Howard C. Reiche Community School

The Howard C. Reiche Community School (Reiche), is an urban school that was built in 1972 to meet the educational needs of young students in Portland's historic West End neighborhood. The school sits on 5.2 acres and is 88,481 square feet with 18 classrooms. The school currently serves 317 students in grades kindergarten through fifth grade. Over half of the students come from countries outside of the United States representing 48 countries and speaking 28 different languages (Portland Public Schools, 2009). Currently 12% of those students have been identified for assignment in English Language Learners (ELL) classrooms (New England School Development Council, 2009). According to a 2002 study, 89% of Reiche's students qualified for free or reduced lunch programs (Portland Public Schools, 2002).

The school is a two-story, brick-faced building built on an open-space school concept with a capacity of 371 students. In order to create visual and acoustic boundaries between the classrooms, office-style divider wall partitions have been added between classes. These partitions do not extend to the ceiling which creates noise problems between classrooms according to a recent study (New England School Development Council, 2009).

At capacity the school has (New England School Development Council, 2009):

- 3 Kindergarten classes of 18 students each
- 6 Grades 1-2 classes of 20 students each
- 7 Grades 3-5 classes of 23 students each
- 1 Primary ELL class of 16 students
- 1 Intermediate ELL class of 20 students

When the school is enrolled to capacity, because of the building's configuration, students in classes on the building's perimeter must walk through another classroom in order to get to the main corridor. Currently, this scenario has been alleviated because the school is enrolled under capacity.

The first floor of the building houses a large central library with an atrium adjoining the main corridor of the first and second floor open classroom spaces. Just outside of the library there is a tiled area that is used as a lunchroom and lobby area. There are ten classrooms on the first floor of the building and eight classrooms on the second floor. On the Brackett Street side of the school there is a small vehicle drop-off area which is used by parents before and after school. There are two buses which bring students to school and park on the Clark Street side. The majority of students at the school walk or bicycles from their homes.

In addition to its function as a school, the building also houses a community health clinic, community pool, community center, gym and locker rooms, and a public library branch. The West End Neighborhood Association, the local neighborhood group, also hopes to have the community policing center moved to the school from its current location on the other side of the neighborhood. After school hours, the large multi-leveled, carpeted common areas just beyond the lunchroom/lobby space, with an elevated stage is used for community purposes such as meetings of the local neighborhood association, extended day and recreation department programming. The school's playground, outdoor basketball courts and fields are constantly busy with activity from local children and adults, and the building's gym also serves as the polling location for families in the West End.

Because the building houses community center features and school features, facilities management and maintenance of the site is divided in half with the West portion of the school, which houses the community center managed by the City of Portland and the East side of the school and its playground managed by the School Department. In June 2009 the City of Portland elected members to a newly created Charter Commission to examine and make recommendations to the city regarding issues such as these, which may result in the correction of this problem.

The Facilities Planning Report card, developed by the New England School Development Council, listed the following areas that need improvement in the current school:

- Technology Instruction Capacity
- Small Group Instruction
- Field Space
- Nurses Area
- Guidance/Social Work/Other Staff

- Special Education
- OT/PT
- Storage Space
- Parking
- Traffic Flow
- Cafeteria (NA)
- Kitchen (NA)
- ADA Compliance
- Phone/PA System*
- Security (Access)*

*Needs improvement and should be a priority

Specific challenges detailed the report found include:

- Limited phone access in the building due to lack of permanent walls
- Egress issues with the contiguous community center
- Lunch is served in the building main hall with food prepared off site as there is no kitchen
- Lack of ADA accessibility: there are no elevator/lifts in the building, which has multiple levels
- The FLS District Special Needs program is in a regular classroom with an exterior door – near group laboratories
- OT/PT space is in a flex/terraced common area

The Portland Long Range School Facilities Report describes, with the chart below, how six major program changes in the last 40-50 years have affected space use and capacity of schools.

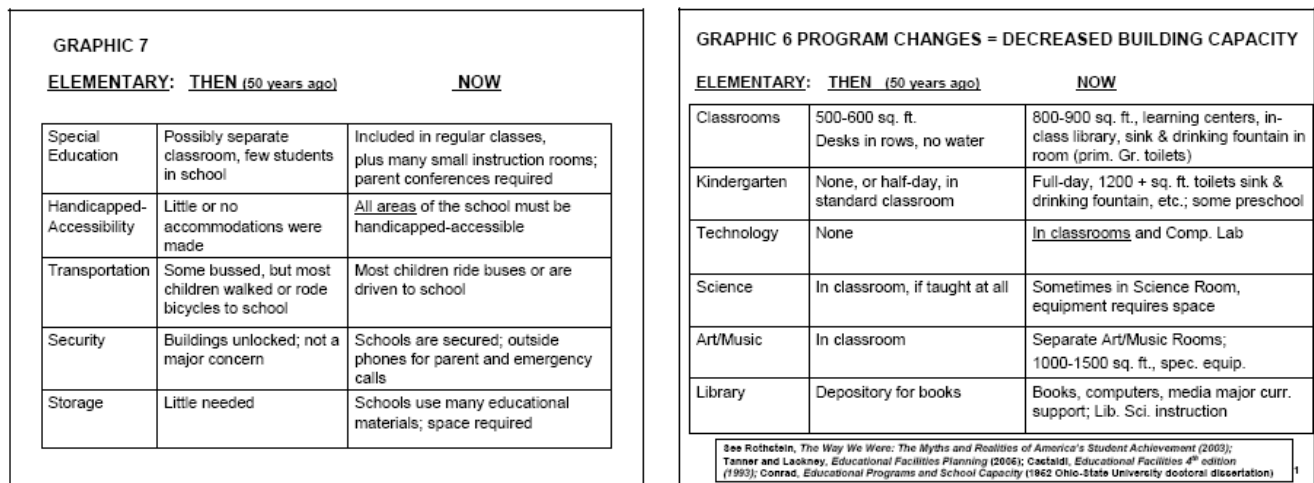

Figure 1: Comparison of program changes over the last 40-50 years (New England School Development Council, 2009).

Changes like full-day kindergarten, which Reiche currently has, as well as much larger classrooms, and technological advantages make it easy to see why administrators at these current schools are looking anywhere they can find for space. Adding in modern accessibility requirements, new security measures, storage and special education requirements makes it even more difficult. It should be noted that square footage guidelines for Maine classrooms are currently 800 square feet, compared to 900 feet nationally,

though many of Maine’s older buildings have much smaller spaces (New England School Development Council, 2009).

Howard C. Reiche Community School Program Needs

The following are program needs which were identified in the 2009 New England School Development Council Report on the School.

- Small instructional spaces
- Teacher workrooms
- Science rooms
- Special needs program spaces- ELL (English Language Learners), FLS (Functional Life Skills)
- Permanent walls for classrooms
- Dividers for multiple staff sharing space
- Consider Spaces for Preschool
-

Table 11: Current Program Distribution

Current Program Distribution			
Reiche School		Community Center Space Programming (30,350 square feet):	
<i>Lower Level</i>	<i>Square Feet</i>	<i>Lower Level</i>	<i>Square Feet</i>
Administrative office/reception	3,500	Lobby	2,600
Teacher’s lounge	375	Cafetorium lower	1,500
Teacher restrooms	60	Cafetorium upper	2,000
Library	4,150	Stage	1,250
Library Support	1,330	Kitchen	600
Boy’s bathrooms	235	Storage/support	3,500
Girl’s bathrooms	245	Corridor	900
Chase	30	Gym	5,600
Janitorial	95	Bathrooms	250
Greenhouse	225	Girl’s locker	1,200
Stairs	400	Women’s locker	500
Other (classrooms/open space)	17,410	Gym offices	250
Total Lower Level	28,080	Boy’s locker	1,200
		Men’s locker	500
<i>Upper Level</i>		Janitorial/support	250
Janitor	90	Pool room	4,400
Boy’s bathrooms	235	Total Lower Level	26,500
Girl’s bathrooms	245		
Chase	30	<i>Upper Level</i>	
Community Health Center	2,050	Music room	1,250
Greenhouse	250	Music Storage	500
Stairs	400	Upper lobby	250
Music	1,170	Library	1,850
Other (classrooms/open space)	22,200	Total upper level	3,850
Open to below	2,800		
Total Upper Level	29,250	Total interior space:	30,350
School Total	57,333	Roof terrace:	2,380

The Building Site:

The site of the Howard C. Reiche School was previously four city blocks. When the neighborhoods were razed in order to make way for construction of the school three streets disappeared: Bradford Street, Varnum Street, and a block of Spruce Street. These neighborhoods created a 5.2 acre parcel which is now occupied by the school. While Bradford Street and Varnum Street are now gone, the design of the school sought to ensure that residents of the West End would be able to travel from Brackett to Clark Street, and so a ramp was built, along the lines of Varnum Street allowing pedestrians to pass from Brackett to Clark. The edge of the community center space is bordered by a brick sidewalk, with a Bradford Street sign visible on the building's corner.

The West portion of the site is bordered by a row of commercial businesses: a laundry mat, gourmet deli, restaurant, pizza eatery and veterinary clinic. A Cumberland Farms convenience Store and gas station lies just across the street and is a favorite spot for the Reiche children to buy frozen treats after school on warm days. The rest of the block is undisturbed, save the school. On the North side of Brackett Street there is an organization called Learning Works (formerly Portland West) which provides free afterschool tutoring to students living in the West End, an evening community computer lab and adult education lessons for adults seeking a GED and English Language Learners. Across from the school is a building which houses a neighborhood grocery store, Fresh Approach. The building also houses a Mosque on the 2nd floor, and is the home of the Shoestring Theatre and the West End Yoga and Dance Studio. The South and West edges of the school are bordered by garden-rise, stick frame residential multi-family housing built in the late 1800's after the Great Fire of 1866 which destroyed 1,500 buildings in the city and left 10,000 people homeless (Varney, 1886).

The school is currently just north of the City of Portland's International Airport, the Portland Jetport's flight path (Portland International Jetport, 2009). The jetport's planes passing overhead are known to rattle windows in the neighborhood. The presents acoustical challenges for the building, in addition to those from traffic and activity in the school's urban neighborhood.

The boundary of the West End is defined by the West End neighborhood Association's bylaws as;

The geographic boundaries of the West End Neighborhood Association shall be:

Northern Boundary	Along Congress Street from St. John Street to High Street
Eastern Boundary	Along High Street from Commercial Street to Congress Street
Western Boundary	Along St. John Street from Congress Street to Commercial Street
Southern Boundary	Along Commercial Street from High St. to St. John Street

Excluded are those areas falling within the boundaries established by the Western Promenade Association, February 2004.

These boundaries place the Howard C. Reiche School near the center of the West End community.

Reiche School's Current Energy Consumption

Portland School District Facilities Director, Doug Sherwood, has been working to reduce the energy consumption of the district's schools. The district has installed energy efficient lighting, lowered

temperatures in school buildings and implemented sustainable building and energy saving strategies in new buildings.

The last building the district completed, The East End Community School, received a LEED Silver rating under the LEED for New Construction version 2.0, the first at a public school in Maine (Maine Chapter of the USGBC, 2009). It was just shy of meeting the ASHRAE Advanced Energy Design Guide for K-12 Schools: 30% savings goal over ANSI/ASHRAE/IESNA Standard 90.1-1999 minimums. Mr. Sherwood hopes that the district next new building will meet or exceed this standard.

Energy Consumption Reiche School (Portland Public Schools, 2007)

Fiscal Year	Oil (Gallons)	Electricity (KWH)	Water (HCF)
2007	40,540.6	474,240	1,393
2006	40,540.6	525,800	1,466
2005	42,988.3	562,400	1,572
2004	41,575.0	537,360	1,665
District Average (2007)	34,658.4	360,881	870

Design Considerations

- Acoustics: between classrooms, community, and airport traffic overhead
- Flexibility: changing needs, diverse users
- Energy consumption: reduce dependence on fossil fuels and burden on school budget for fuels
- Community connectivity: services, outreach, building/site use
- Robust construction: minimize maintenance & costs, easy-to-use systems, long-service life

Building/Code Requirements for City of Portland, Maine

- LEED for Schools version 3.0 Silver minimum (Portland City Code Chapter 6, Article VII Green Building Code)
- Enough LEED Optimize Energy credits to meet the Architecture 2030 Challenge (Portland City Code Chapter 6, Article VII Green Building Code)
- International Code Council (ICC)
- ASHRAE Advanced Energy Design Guide for K-12 Schools: 30% savings over ANSI/ASHRAE/IESNA Standard 90.1-1999 minimums (School District facilities goal)

Acknowledgements

-Douglas Sherwood, Portland Public School District: Facilities Manager

-Alan Holt, Community Design Studio: Reiche Community Center Planning Facilitator (2005)

References

- American Planning Association (2008). American Planners Recognize 30 Great Neighborhoods, Streets, and Public Places, www.planning.org/newsreleases/2008/oct08.htm (June 14, 2009).
- City of Portland, Maine (2009). About Portland. www.ci.portland.me.us (June 14, 2009).
- Farish, Terry (2003). Regional Review. A restaurant in Portland links African refugees with their past and Maine with its future. Federal Reserve Bank of Boston. Oct. 03, 33.
- Greenburg, Zack (2009). America's Most Livable Cities. Forbes Magazine, www.forbes.com/2009/04/01/cities-city-ten-lifestyle-real-estate-livable-cities.html (June 14, 2009).
- Maine Chapter of the United States Green Building Council (2009). East End School, www.maineusgbc.org/index.php?module=Projects&func=display&pid=20 (June 14, 2009).
- New England School Development Council (2009). Long-Range School Facilities Planning, Portland, Maine. April 2009, 4, 8, 10, 17, 31.
- Portland International Jetport (2009). Aircraft Noise and Flight Monitoring System: Harbor Visible Flight Tracks, www.portlandjetport.org/NOISE.ASP (June 14, 2009).
- Portland Public Schools (2002). Comprehensive Elementary Facilities Plan, 30.
- Portland Public Schools (2007). Energy Consumption in Portland Schools 2007, www.portlandschools.org/facilities/documents/EnergyConsumption07.htm (June 14, 2009).
- Portland Public Schools (2008). Facilities Building Capacity, Joint Financial Committee Report 2008, 1.
- Portland Public Schools (2009). Multilingual and Multicultural Center. About Us, www.portlandschools.org/schools/multilingual/about.html (June 14, 2009).
- Portland Public Schools (2009). Principal's Welcome To Reiche School, <http://reiche.portlandschools.org/> (May 25, 2009).
- Relocate America (2009). Top 100 in 2009, <http://top100.relocate-america.com> (June 14, 2009).
- Simon, Scott (2006). National Public Radio, Weekend Edition. Sudanese Refugees Find New Home in Maine. April 29, 2006.
- U.S. Census Bureau (2000). State and County QuickFacts. Data derived from Population Estimates, 2000 Census of Population and Housing, 1990 Census of Population and Housing, Small Area Income and Poverty Estimates, County Business Patterns.
- Varney, Geo. J. (1886). History of Portland, Maine. A Gazetteer of the State of Maine. B.B. Russell, Boston.
- Walljasper, Jay (2008). Destination Scorecard: 109 Places Rated. National Geographic. Nov/Dec. 2008, 120.
- WMTV8 (2009). Baldacci Meets with Sudanese Community Leaders, May 19, 2009.

CHAPTER 3

PRECEDENT STUDIES

Introduction

The following six elementary schools were selected as precedents for the Howard C. Reiche Community School (Reiche) project. They are:

United States

Bethke Elementary School (Timnath, Colorado)
St. Thomas School (Medina, Washington)
Rosa Parks School (Portland, Oregon)

United Kingdom

New Minster School (Southwell, Nottinghamshire)
Kingsmead Primary School (Northwich, Cheshire)
Bridge Academy (Hackney, London)

Three of these schools, Bethke, St. Thomas and New Minster, have been rated via either LEED Schools or BREEAM Education. These schools were selected in order to examine how their design teams integrated sustainable design techniques which are rewarded under LEED and BREEAM into the projects as the Reiche project is required to meet a LEED Silver Standard by the city of Portland, Maine.

The Rosa Parks School and Kingsmead School were not rated via LEED Schools or BREEAM Education because they were built prior to the creation of specific assessments for education by LEED and BREEAM. The Rosa Parks School did receive a LEED rating under LEED for New Construction and Kingsmead is referenced by BREEAM in the unveiling of their BREEAM Education model. The Rosa Parks school most closely resembles Reiche school's siting and program, with its neighborhood based, community center model.

The Bridge Academy was selected because like Reiche, it has a limited urban site. It was selected for the creative methods via which it addressed this problem via building structure and form. This building has not sought a BREEAM rating.

The Schools

The following section details information about the six schools via comparison and narrative description, including information about project cost and site, the design team and their interactions with the various user groups and community constituencies, sustainable design techniques utilized and program layout.

Table 1: Precedent Project Overview

Name	Built	Ft ²	Levels	Students	Cost (M)	\$/ft ²	Rating
Bethke	2008	63,000	2	525 (K-6)	\$9.9	\$157.14	Gold v.2.0
St. Thomas	2008	55,000	2	300 (Pre-6)	\$20	\$363.63	Gold v.2.0
Rosa Parks	2006	66,863	2	550 (K-6)	\$12.8	\$191.43	Gold NC
New Minster	2007	208,000	2	1,600 (6-12)	\$39.1*	\$187.98	Very Good
Kingsmead	2004	19,375	1	150 (K-5)	\$3.9*	\$201.29	Not rated
Bridge	2008	166,840	2-7	1,150 (6-12)	\$81.5*	\$488.50	Not rated

*assumes an exchange rate of £1.63 to \$1.00.

Bethke Elementary School

Bethke Elementary School is a public elementary school in the foothills of the Rocky Mountains near Fort Collins, Colorado. The area has a moderate climate with an average of 300 days of sunshine and 14.5 inches of precipitation per year (Pourde School District, 2009). The school is located in a suburban setting and in addition to achieving the first LEED rating via the LEED Schools scheme, also received recognition by

the Green Building Initiatives' environmental assessment method, Green Globes, earning three green globes, another first (Green Building Initiatives, 2008).

The school was designed by RB+B architects as a prototype building for the district. The firm previously worked with the district to design the area's high school in 2004, which was highly regarded as an example of sustainable architecture. Since this project the firm also designed four other elementary schools and one junior high school for the district (Green Building Initiatives, 2008). The Bethke Elementary School's program is arranged with acoustics in mind so that quiet activities are organized in one area of the building and active, noisier activities in another area. Building services are exposed within the building to allow the district to use the building as a learning tool (RB+B Architects, 2009).



Project Design Team:

- Architect: RB+B Architects
- Contractor: Dohn Construction Inc.
- Structural Engineer: JVA, Incorporated
- Mechanical/Electrical Engineer: Shaffer Baucom Engineering & Consulting
- Civil Engineer: Northern Engineering
- Landscape Architect: The Birdsall Group LLC
- Irrigation Engineer: Aqua Engineering, Inc.
- Commissioning Consultant: Architectural Energy Corporation
- Kitchen Consultant: William Caruso & Associates

Figure 2: Bethke Elementary School entrance (RB+B Architects).

Sustainable design techniques and features in the design scheme include:

- 90% of the building's spaces are lit via daylighting, some via solatubes
- a high-efficiency building envelope with super-insulated walls and roof
- high-efficiency mechanical and electrical systems designed to save 40-50% in operating costs
- operable windows for controlled occupant comfort and ventilation
- evaporative cooling throughout the building (except in the gymnasium)
- non-potable water for irrigation
- low-flow plumbing fixtures
- heat recovery ventilation system
- high albedo paving
- building automation system available for viewing via students on the school's computers

Floor plans of Bethke Elementary School illustrating the school's 'active' zones on the South and 'passive' classroom spaces on the North.



Figure 3: Bethke Elementary School Floor Plan (Environmental + Design Magazine courtesy of RB+B Architects).

These techniques are some of the reasons why the school was designed to use 40-50% less energy than a typical school without such sustainable features. This produces a CO₂ offset of 61 tons per year. The building uses 26.9 KBTU/ft² per year, compared to a Colorado average of 70 KBTU/ft² per year. The building also received an Energy Star rating of 95 out of 100 (Green Building Institute, 2009).

Bethke Elementary School stairwell illustrating the building's concept of displaying the building's various services to enhance student learning.

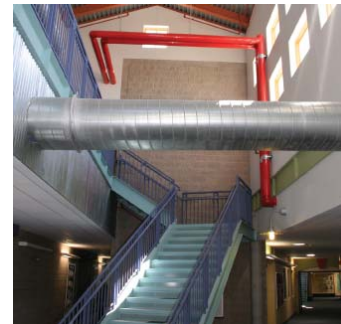

Figure 4: Bethke Elementary School Stairwell (Green Building Institute, 2009).

After occupancy the school district planned to add a 10 kW photovoltaic system. The project received 44 of 47 credits attempted out of 79 possible in the LEED Schools v2.0 rating system. To view the project's credit report and information about the building materials used see section appendix.

St. Thomas School

St. Thomas School is located just outside of Seattle, Washington in Medina, home of Microsoft Chairman Bill Gates and boasts one of the highest per capita incomes in Washington (Folkers, 1997). The area has a mild climate, with a wet winter and dry summer with an average of 191 cloudy days a year (National Climate Data Center, 2002).

The school is Washington State's first LEED Gold school rated under the LEED for Schools rating system. The school also earned an energy star designation under the US Environmental Protection Agency. The cost of the project was \$30,000,000 but included \$10,000,000 in retrofits to a temporary facility the school leased during construction, which took place on the school's existing site (Seneca Real Estate Group, 2009). The school uses the same project managers to facilitate their move to the temporary site as for construction of the new school.

The building earned a US Energy Star rating of 82 out of 100 possible and projections indicate that the building will use 28% less energy than an average building. The building's estimated energy use intensity is 71.3 kBtu/sf/yr with a total estimated annual energy use of 3,921,000 kBtu (US Department of Energy, 2008). This is estimated to save the school roughly \$28,000 in energy costs per year.



Project Design Team:

- Architect: Bassetti Architects
- Project managers: Seneca Group
- Contractor: Sellen Construction
- Structural Engineer:
- Mechanical/Electrical Engineer: Stantec Architecture, Inc.

Figure 5: St. Thomas School Cafeteria and Gymnasium (Bassetti Architects).

Sustainable design techniques and features in the design scheme include:

- passive ventilation in classrooms
- low VOC, and recycled content in building materials
- porous asphalt and concrete
- drought tolerant plants
- stormwater is treated on site and released into a nearby stream at a highly controlled rate
- high efficiency equipment and lighting with occupancy sensors
- use of energy efficient laptops instead of desktop computers
- radiant heating
- daylighting

As would be expected, the building does not utilize photovoltaic panels due to the building's location. Unlike the Bethke Elementary School which is located in an area with 300 days of sunshine a year where such a system would provide better results.

At right is a diagram illustrating the building's passive ventilation strategy, which utilizes operable windows located near floor level and the stack effect to ventilate the building (US Department of Energy, 2009).

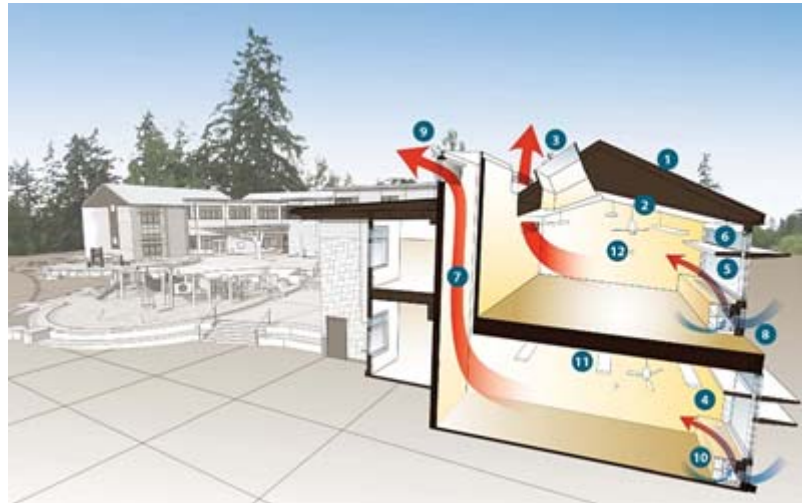

Figure 6: St. Thomas School Passive Energy Diagram.

The project earned 44 of 79 points available via the LEED Schools version 2.0 rating system. To view the project's complete LEED credit report see section appendix.

Rosa Parks School

The Rosa Parks School was designed not only to provide educational facilities but also to become a neighborhood and community center. The project, designed to help spur neighborhood revitalization, is located on a 2.38-acre site near the campus of a low-income housing project, with the school serving as the heart of the project.

In order to capitalize on financial constraints area non-profits who would provide services to the community were brought into the design and planning process. The result is much more than a school building. The large school is divided into 125 student "neighborhoods." The neighborhoods each house five classrooms, a resource/support room and support functions around a "Neighborhood Commons." The school's entry has a family resource room, as well as access to a library information center. Functions such as art, computers, music and food service are shared with the new Boys and Girls Club.

The sustainable features present in the building are predicted to account for a 24% reduction in energy use in the building as compared to an average building designed to meet the minimum requirements of ASHRAE Standard 90.1-1999.



Project Design Team:

- Owners: New Columbia Community Campus Corporation, Portland Public Schools, Housing Authority of Portland, Boys and Girls Club of the Portland Metropolitan Area
- Architect: Dull Olson Weekes Architects
- General Contractor: Walsh Construction
- Structural Engineer: ABHT Structural Engineers
- Acoustic: SSA Acoustics
- Mechanical/Plumbing Engineer: Mazzetti & Associates
- Electrical & Low Voltage: Reyes Engineering
- Civil Engineer: KPFF Consulting Engineers
- Landscape Architect: Atlas Landscape Architecture
- Irrigation Engineer:
- Commissioning Consultant:
- Food Service: Halliday & Associates

Figure 7: Rosa Parks School (Gary Wilson, Photo/Graphic)

Sustainable design techniques and features in the design scheme include:

- pedestrian pathways serving the largely walk-in student population
- daylighting
- storm water management plan which keeps all stormwater on site
- photovoltaic electrical panels which produce 1.1-kilowatts and a kiosk showing the system's real-time electricity production for student's and visitors
- displacement ventilation
- recycling of 97% of construction waste
- 31% of materials were locally sourced and manufactured
- low VOC building materials and paints
- 'green' cleaning and pest management program

The diagram at right illustrates how the school shares its site with both the community and the Boys and Girls Club.

The school is located to the South with shared space including the cafeteria and auditorium separating the school from the Boys and Girls Club.

Figure 8: Rosa Parks Elementary School Plans (Dulles Weekes Architects)



The project earned 42 of 69 points available via the LEED New Construction version 2.0 rating system. To view information about the building materials used in the project see section appendix.

New Minster School

The New Minster School is located on the edge of a densely populated picturesque Georgian village and owned by the Southwell Diocese Board of Education. Its site is bordered by a large conservation area. The project joins the school, originally split on two sites, half a mile apart, on one site with playing fields. The project represented the largest building project in the town since the nearby Minster Cathedral, dating back to 11th Century (Penoyre & Prasad, 2009).

The school has specialist status in both humanities and music. Its pupils include a sixth form and small junior department, which trains choristers for Southwell Minster. The project bridges the current town and the countryside and responds to these settings with different cladding on different elevations. The long elevations are clad with traditional brick, which matches the vernacular of the town and black timber, which blends it into the landscape beyond.

The building program is formed around an internal central street, a 'heart space' where the entire school can gather as a community. Administrators of the school felt flexibility and adaptability over time in the building was an important feature and as a result, movable acoustic walls along the internal street allow flexibility while providing acoustic privacy when closed. Lightweight panels were also used which can be easily disassembled to reconfigure spaces as the needs of the school change over time.

During the design process a renewable energy strategy was rejected due to cost so the design focused its efforts on reducing the building's energy consumption and utilizing passive design techniques. The design team took a collaborative approach with the school and the contractor throughout the construction process. Consultation extended beyond school users and involved a variety of commuting group including: extended learning users, local civic society, rugby club, leisure center, etc. Interaction with the client included building visits to other schools and buildings which helped the client visualize various spatial devices and materials that could be utilized in the project.

Workshops were also held with over 90 pupils, which were selected from the school council. Students discussed key common areas of the school, and their ideas for those spaces. A virtual three dimensional model was built illustrating the ideas, and providing the students with illustrations on the scale and relationship between the internal and external spaces the students were designing. Later a model was built for the whole school which was used by administrators for presentations, fundraising and publicity.

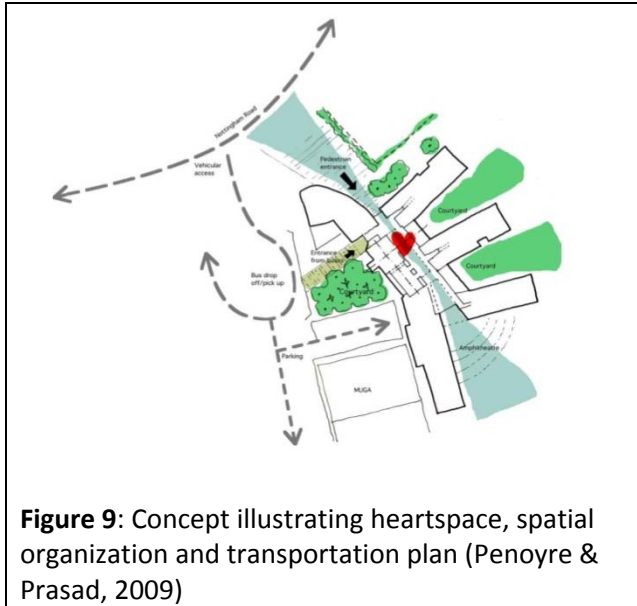

Figure 9: Concept illustrating heartspace, spatial organization and transportation plan (Penoyre & Prasad, 2009)

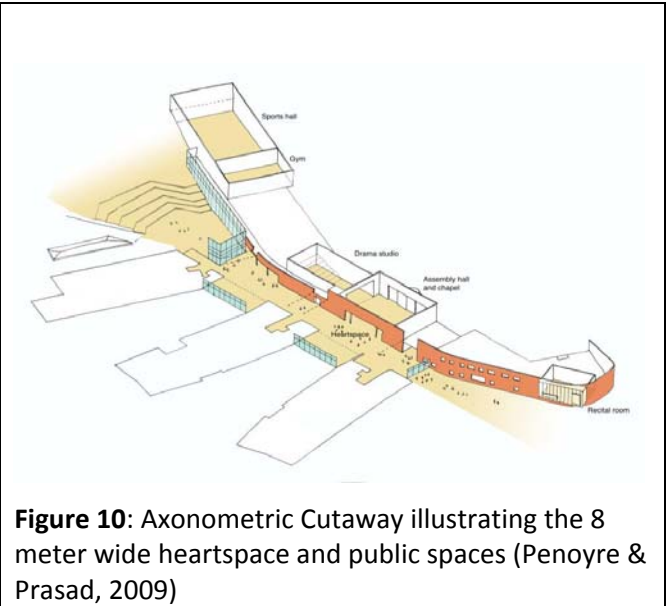

Figure 10: Axonometric Cutaway illustrating the 8 meter wide heartspace and public spaces (Penoyre & Prasad, 2009)

The project was designed to meet an Energy 3x CIBSE benchmark with total design emissions of $14.41\text{kgCO}_2/\text{m}^2$. This includes $15.3\text{kWh}/\text{m}^2$ ($6.34\text{kgCO}_2/\text{m}^2$) for electrical energy and $41.56\text{kWh}/\text{m}^2$ ($8.07\text{kgCO}_2/\text{m}^2$) for space and water heating. Post occupancy evaluation figures were $45\text{ kWh}/\text{m}^2$ for electricity and $20\text{ kWh}/\text{m}^2$ for gas, thus exceeding the design limits. Heating expenditures were below typical average but electrical use was much higher (Penoyre & Prasad, 2009). The designers note that these figures illustrate that the building management system used in the classrooms to enable user control needs fine tuning and that local control has not been as effective as anticipated.

Lighting accounted for 45% of the energy costs, which may also indicate the daylighting scheme is not working as well as planned. This figure compares with a CISBE benchmark of 12% of energy used for lighting. User behavior was also cited as a factor with lights on in rooms, and blinds drawn down, even when the rooms were not in use. One strategy that will be used to combat the energy use is changing lamps from 70W to 50W and changing user controls.



Project Design Team:

- Architect: Penoyre and Prasad
- Contractor: Galliford Try Construction
- Structural Engineer: Buro Happold Ltd.
- Mechanical/Electrical Engineer: Buro Happold Ltd.
- Civil Engineer: Buro Happold Ltd.

Figure 11: Heart space, New Minster School (Buro Happold)

Sustainable design techniques and features in the design scheme include:

- natural ventilation via operable windows in classrooms and ventilation chimneys
- occupancy and daylight dimming sensors
- heat recovery
- orientation of the building to promote daylight (classrooms are oriented North/South to reduce glare and overheating)
- high thermal mass which promotes free cooling
- water efficient fixtures, gray water for flushing toilets and irrigation, 6 cisterns to collect rainwater
- recycled building materials and consideration of a materials environmental impact
- double glazed windows with solar glazing on South and West facades
- green roof to improve thermal performance, biodiversity and attenuate runoff since flooding of the previous school was a particular problem
- low energy lighting
- building management system to control heating and ventilation at the classroom level

The project earned 42 of 69 points for a 'very good' rating via the BREEAM Education issue 1.0. To view information about the building materials used in the project see section appendix.



"It's a bright sunny Autumn Day today. The school and landscape is looking stunning. We're thrilled by the way the students have settled in. A very calm atmosphere. The environment, inside and out, is having a profound impact on staff and students. We are so lucky! Thanks."

Phil Blinston, Head Teacher

Figure 12: New Minster School (Penoyre & Prasad, 2009)

Kingsmead Primary School

Kingsmead Primary School is located in Cheshire County in a small civil parish that has been used for salt pans since Roman times. The Cheshire County Council decided to build a new primary school that would be an exemplar for sustainable design (CABE, unknown).

The Cheshire County Council hired Wilmot Dixon via a design/build procurement contract. The council had prior experience with Wilmot Dixon, who had Wilmot Dixon then chose White Design Associates, Ltd. as architects of the project. The pair had successfully worked together previously on a successful design competition. White Design was commissioned five months prior to the commencement of construction and construction of the school was completed in a short nine months. Permits for construction were taken out ten weeks prior to White Designs commissioning.

The planning team met weekly on site, following White Design's selection. The team included:

- White Design
- Wilmott Dixon
- County Education and Property Department Representatives
- A former headteacher as education advisor
- Planning officer from the council

By week three the design team had selected a basic form in terms of section and plan views. The design of the building was completed and a contract sum fixed within another three months. The building is timber clad and framed. Its shape and structure are characterized by a series of glulamined wood arches which give the roof its butterfly form. Wood was selected due to its low embodied energy. The arches are at 5 meter centers and offset by 4 degrees which creates the crescent shape of the building's footprint.

The tall windows on the North façade of the building provide glare-free daylighting for the classrooms without solar gain. Leading to the exterior on the North façade 'winter gardens' are shared by two classrooms each. These spaces were designed to act as an air-lock to reduce heat loss when the children open the doors and a space to grow plants in the wintertime.



Project Design Team:

- Architect: White Design Associates Ltd
- Contractor: Wilmot Dixon, Birmingham
- Structural Engineer: Mander Structural Design
- Mechanical/Electrical Engineer: Arup
- Environmental Engineer: Arup/Mitie Engineering Services

Figure 13 (Top to Bottom): Kingsmead Primary School, Glulamined Structure during construction (White Design).

Sustainable design techniques and features in the design scheme include:

- rainwater collection providing 32% of water use in the building
- north orientation of classrooms for glare-free daylighting
- rapidly renewable and low VOC materials such as bamboo flooring, linoleum and recycled carpet
- biomass boiler using pellets made at a local factory
- building management system that enables monitoring by students
- photovoltaic arrays providing 6% of the building's electricity (projections were 15%)
- 20% of hot water is heated via solar hot water collection system on roof
- stormwater management system using existing swales and ponds
- temperature sensors which control the opening of windows during lunchtime and breaks for ventilation

Like the New Minster School, Kingsmead has not lived up to the energy performance projections of its designers. One problem is the biomass boiler which is 80% efficient and nearly carbon neutral has not been functioning properly, requiring use of the gas boiler. Also, electricity consumption is much higher than anticipated with use of 70 kWh/m², more than three-and-a-half times the government's target consumption rate. This increase was attributed to: use of the building during the evenings when artificial lights are needed, running kitchen equipment during holiday breaks, and extensive use of electronic equipment. Water use, is on target with 420 m³ used in 2005. (Palmer ,2006).

Currently the Kingsmead students' Eco-group have met a travel target of 80% of the students walking/cycling or scooting to school, even in winter (Kingsmead, 2009).

To view information about the building materials used in the project see section appendix.

Diagram illustrating layout of the Kingsmead Primary School with classrooms and the school's library (at center) on the North façade and building services, kitchen and assembly area on the South.

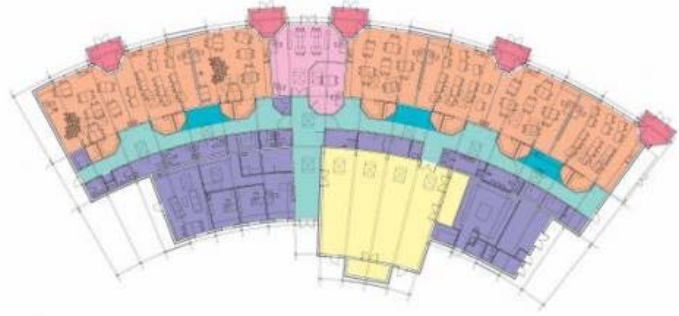

Figure 14: Kingsmead Primary School Plan (CABE, date unknown)

Bridge Academy

Bridge Academy, in London, is a school which specializes in music and maths. The school was built in a neglected area of Hackney, on a former brownfield site confined by the Regent's Canal on one side. The buildings daring structural form earned engineers, BDP, an Engineering Excellence Award, and is appropriate considering the school's specialty: maths. The project also earned an award for using building information modeling, the Bentley BE Award for the Best Use of BIM (Evans, 2009).

Due to the confines of the small building site, maximizing the space available was key to the project's success. This was done by utilizing building roofs to house playing fields and in the building's form which grows out as it extends upward.

Photograph illustrating the project site along the banks of the Regent's Canal.

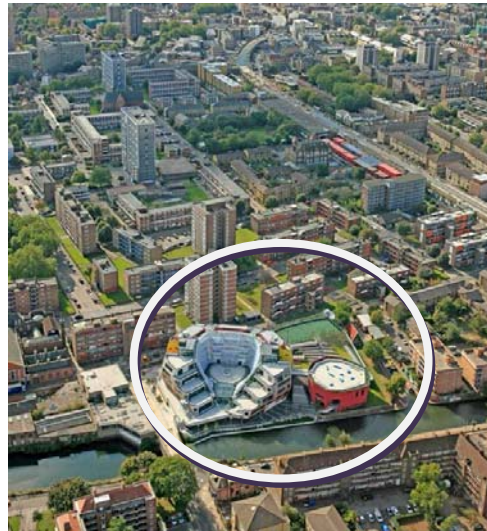

Figure 15: Bridge Academy Aerial Photo (BDP)

The site houses four buildings which make up the school. They include: a main seven level horse-shoe shaped building with a hoop-shaped roof housing classrooms, and the school's library, which hangs, suspended in the building's center. There is also a red octagonal 'music box' sitting along the canal housing a 450-seat auditorium, a parking garage which an outdoor amphitheatre for outdoor teaching and a sunken sports hall with a playing field on top of the roof.



Project Design Team:
 -Clients: Department for Children, Schools and Families and UBS Investment Bank
 -Architect: BDP
 -Contractor: Mace Plus
 -Structural Engineer: BDP
 -Mechanical/Electrical Engineer: BDP
 -Civil Engineer: BDP

Figure 16: Bridge Academy from across the canal (Credit, Martine Hamilton Knight).

The main building utilizes BDP’s concept of ‘schools without corridors’ which aims to maximize social cohesiveness and also seeks to develop a ‘school without columns.’ The structural design of the school allows for ‘total flexibility’ and provides a column free central learning hub. The two-story library is supported by large tubes which line the edge of the horse-shoe. These create a large column-free space on ground level for break-out or information teaching.

Bridge Academy conceptual site and main building section illustrating corridor-free spaces.

Figure 17: Sectional Diagram (BDP)

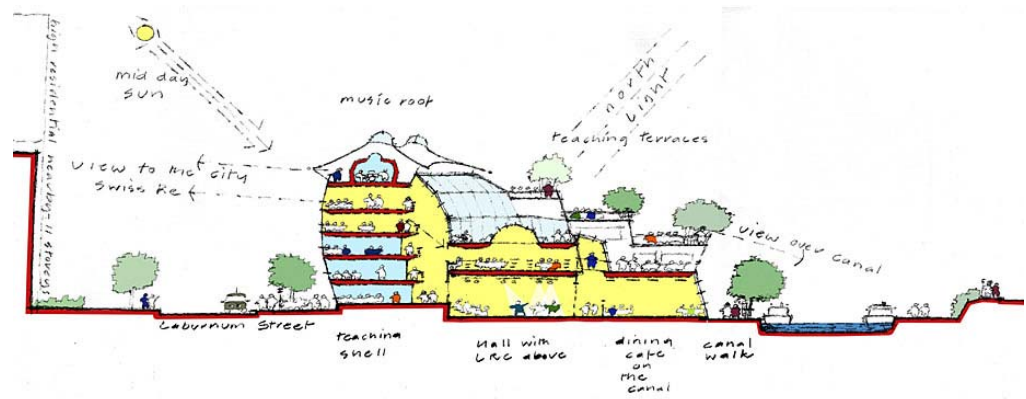

Due to the Design and Build Contract, and the fact that BDP served as both designer and engineer allowed BDP to specify that all members of the design team use building information modeling (BIM) software for the project. This was particularly helpful in designing the intricate structural design of the building and for the integration of its building services. The team also used physical three-dimensional models visualize the spatial and structural properties of the building. The structural design analysis software package used was Robot.

Sustainable design techniques and features in the design scheme include:

- natural ventilation
- daylighting in classrooms

Acknowledgements

- Martin Cook, British Research Establishment: Special Project’s Team
- Rafael Marks, Penoyre & Prasad, LLC: Principle Architect New Minster School
- Corky Bradley, RB+B Architects: Blethke School Architect
- Kristian Kicinski, Bassetti Architects: St. Thomas School Architect

References

- Architectural Record (2007). Rosa Parks School. http://archrecord.construction.com/projects/bts/archives/K-12/07_RPSPortland/Default.asp (September 4, 2009).
- BDP (2009). Bridge Academy. <http://www.bdp.com/Projects/By-Name/A-E/Bridge-Academy/?category=18&parentpageid=24> (September 6, 2009).
- Bradley, Corky (2009). Environmental Design and Construction. Practice Makes Perfect. http://www.edcmag.com/CDA/Articles/Article_Rotation/BNP_GUID_9-5-2006_A_1000000000000530869 (September 7, 2009).
- Commission for Architecture and The Built Environment (date unknown). Kingsmead Primary School: Northwich, Cheshire. <http://www.cabe.org.uk/case-studies/kingsmead-primary-school> (September 6, 2009).
- Evans, Brian (2009). Constructing Excellence. Demonstration Projects Knowledgebase: Bridge Academy. <http://demos.constructingexcellence.org.uk/knowledgebase/main.php?ProjectID=3440> (September 6, 2009).
- Folkers, Richard (1997). US News and World Reports. Xanadu 2.0 Bill Gates's stately pleasure dome and futuristic home, November 23, 1997.
- Green Building Initiative (2008). Green/Sustainable Building News. Green Building Initiative™ Recognizes Pourde School District's Bethke Elementary School For Sustainable Design and Construction Achievement. http://www.thegbi.org/news/news/2008/news_200809012_bethke_elementary.asp (September 4, 2009).
- Green Building Institute (2009). Case Study: Bethke Elementary School, Green Building is Elementary. <http://www.thegbi.org/assets/pdfs/Bethke-Elementary-School.pdf> (September 7, 2009).
- Kingsmead Primary School (2009). Travel Target. <http://clc2.uniservity.com/GroupNews.asp?GroupID=175899> (September 6, 2009).
- National Climate Data Center (2002). Cloudiness - Mean Number of Days. <http://lwf.ncdc.noaa.gov/oa/climate/online/ccd/cldy.html> (September 4, 2009).
- Palmer, Jason (2006). Full Marks for Effort. Building Services Journal June 2006, 43-47.
- Penoyre & Prasad (2009). Minster School: A common sense approach to sustainability. Ecobuild conference (March 4, 2009).
- Pourde School District (2009). Where We Are. <http://www.psd.k12.co.us/psdinfo/whoweare.aspx> (September 4, 2009).
- RB+B Architects (2009). Bethke Elementary School. <http://rbbarchitects.com/portfolio/education/bethke/index.html> (September 4, 2009).
- Schaffer Baucom Engineering & Consulting (2008). Press release: "Bethke Elementary School Achieves first LEED® for Schools Gold" (September 4, 2009).

Seneca Real Estate Group (2009). St. Thomas School: Medina, Washington.

U.S. Department of Energy (2009). Energy Star Building Design Profile: St. Thomas School. Medina, Washington. http://www.energystar.gov/index.cfm?c=new_bldg_design.project_st_thomas (September 4, 2009).

U.S. Green Building Council (2008). Project Profile, Rosa Parks School. <http://www.usgbc.org/ShowFile.aspx?DocumentID=5110> (September 4, 2009).

CHAPTER 4

RETHINKING REICHE RENOVATION PROPOSAL

Project Introduction

The Howard C. Reiche Community School is the heart of Portland's diverse West End neighborhood. It is a place where community members come to swim, shoot a few hoops, or relax with a book at the building's public library branch. The school is a place where one of Maine's most diverse group of students comes together to learn math, science, reading, writing, art, music, and about the unique cultural experiences of their classmates.

The grounds of the Reiche School are as heavily used as its building, serving as a playground for students and those too young or old to frequent its halls outside of school hours. In a densely developed neighborhood where many families are without yards or driveways to play, children ride bikes, scooters and roll on skates on its hard surfaces, throw Frisbees or footballs on its fields and shoot hoops at the school's outdoor basketball court.

The intent of this project is to provide a proposal for renovating the Howard C. Reiche Community School. Major aims of the Portland Public School District are sustainable and energy efficient design and this design proposal was developed with these ideas at the forefront. The school requires that the building receive a LEED for Schools Silver rating (or higher) with enough Optimize Energy Credits to meet the Architecture 2030 Challenge as noted in previous sections of this paper.

The Facilities Planning Report card, developed by the New England School Development Council (2009), listed the following areas that need improvement in the current school:

- Technology Instruction Capacity
- Small Group Instruction
- Field Space
- Nurses Area
- Guidance/Social Work/Other Staff
- Special Education
- OT/PT Space
- Storage Space
- Parking
- Traffic Flow
- ADA Compliance
- Phone/PA System
- Security (Access)

A top priority in the school's programmatic distribution was separating the academic and community functions within the building. The intent of this shift is to increase security at the school by limiting the number of shared entrances students, staff and community members must navigate throughout the day. Currently, for example, the music room is located on the community side of the school and the Community Health Clinic is located adjacent to student classrooms. In moving the music room over to the school side of the building it provides the ability to have a controlled, single access point for visitors entering the school.

Shift to School Side

- Music Room
- OT/PT Space
- Cafeteria

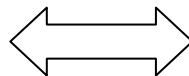

Shift to Community Side

- Health Clinic

Educational Philosophy Guiding Design

Learning takes place in many forms, has many teaches, and occurs in many places. From the playground, to the neighborhood grocery store, in the library and the classroom, students are constantly soaking up knowledge and gaining new life experiences.

There is an African proverb that says “It takes a village to raise a child,” for students at the Howard C. Reiche Community School, this could not be truer.

A school is not a building; it is a community of people working together towards common goals of teaching and learning. The structure facilitating this activity should contribute to helping educators achieve the school’s educational mission and inspire growth among those who inhabit its walls.

Community Center Design Workshop – September 2006

In September 2006 a group of residents and architects, students from the University of Southern Maine’s Muske School of Public Service, and the Maine Chapter of the American Institute of Architects met to discuss the future of the school’s Community Center. The meeting was facilitated by Portland Architect and Muske School Professor, Alan Holt. The seventy participants formed small groups which discussed a variety of issues, including the strengths and weaknesses of the center and their visions for its future use. Below is a summary of the final report on the workshop.

Vision Statements

Team 1: “The new West End Community Center should be a dynamic, spacious, facility that is welcoming, separate from the school, inclusive and reflective of the specialness of the West End Community.”

Team 4: “Provide a framework of opportunity to reinvigorate community participation through active engagement.”

Team 6: “Build and sustain community health and well-being. Goals: teach, feed, grow as individuals and families, have fun, celebrate diversity and create sustainable ways of living”

Site Analysis Conclusions

Positive features: Easy walk for all ages, easy to walk to variety of services and shops, easy walk for lots of interests.

Needs: Signage throughout neighborhood, signage around site, welcoming entries, accessibility to upper level without “heavy-handed” ramps.

Reiche could: provide community gardens, bring entries towards the street, provide covered walkways across the site, create visual and physical connections between the building and site.

Entries: All teams advocated for the removal of the concrete ramps, all teams highlighted entries as areas for improvement, six of nine teams extended entries towards the street.

Types of activities taking place at the Community Center

The Howard C. Reiche Community Center is used for a variety of activities. Below are some examples of activities which currently take place or could easily take place at the center.

- Book group meeting
- Bike commuters meeting
- Hula hooping class
- Yoga class
- Pickup basketball
- Neighborhood Association Meeting
- Cooking class
- Movie night
- Swimming lessons
- Water aerobics
- Lap swimming
- Community garden
- Reiche 5K Road Race
- Voting (polling location)
- Community organizing
- After school care
- Health clinic
- Book swap
- Flu Clinic
- Neighborhood watch meeting
- Dance class

Design Program Requirements

The following are the programmatic space requirements of the Howard C. Reiche Community Center that were used for the purpose of this project.

Table 13: Design Program Requirements

Elementary School Requirements			
#	Description	Space per room	Total Square Feet
3	Kindergarten classes of 18 students	1,200 ft ²	3,600 ft ²
6	Grades 1-2 classes of 20 students	900 ft ²	5,400 ft ²
7	Grades 3-5 classes of 23 students	900 ft ²	6,300 ft ²
1	Primary ELL class of 16 students	900 ft ²	900 ft ²
1	Intermediate ELL class of 20 students	900 ft ²	900 ft ²
1	Music Classroom	1,200 ft ²	1,200 ft ²
1	Music Storage	500 ft ²	500 ft ²
1	Art Classroom	1,200 ft ²	1,200 ft ²
1	Computer Classroom	1,200 ft ²	1,200 ft ²
24	Administrative Offices / Reception	120 ft ²	3,500 ft ²
1	Teacher's Lounge / Restrooms	435 ft ²	435 ft ²
1	Auditorium	3,500 ft ²	3,500 ft ²
1	Lunchroom	2,600 ft ²	2,600 ft ²
1	Greenhouse	500 ft ²	500 ft ²
1	Library	4,150 ft ²	4,150 ft ²
1	Library Support	1,330 ft ²	1,330 ft ²
1	Janitorial	185 ft ²	185 ft ²
2	Boys bathrooms	235 ft ²	470 ft ²
2	Girls Bathrooms	445 ft ²	490 ft ²
1	OT/PT	600 ft ²	600 ft ²
4	Guidance / Social Work	150 ft ²	500 ft ²
2	Functional Life Skills	1,000 ft ²	2,000 ft ²
Total			41,460 ft²

Community Center Requirements			
#	Description	Space per room	Total Square Feet
1	Gymnasium	5,600 ft ²	5,600 ft ²
1	Gym Offices	250 ft ²	250 ft ²
1	Storage / Support (Gym)	3,500 ft ²	3,500 ft ²
1	Community Library	1,850 ft ²	1,850 ft ²
1	Pool	4,400 ft ²	4,400 ft ²
1	Locker Rooms	2,400 ft ²	2,400 ft ²
1	Stage	1,200 ft ²	1,200 ft ²
1	Community Kitchen	600 ft ²	600 ft ²
1	Community Health Center	2,050 ft ²	2,050 ft ²
1	Janitorial / Support	250 ft ²	250 ft ²
1	Bathrooms	250 ft ²	250 ft ²
			22,350 ft²

Design Interventions

There are seven major design interventions that are being proposed as part of the renovation proposal, in responding to the needs of The Facilities Planning Report card, developed by the New England School Development Council and during the Community Center Design Workshop of 2006. The intention of these interventions is to improve the usability, functionality and safety of the building for its various users.

Accessibility

There is a three foot elevation change between the elevations of Clark Street and Brackett Street and their respective entrances. Once inside the school, a series of steps surrounding the auditorium and the school's library bring users back up to street level. This small change in elevation makes the majority of Reiche School inaccessible to individuals with mobility issues. The school also lacks an elevator to carry students or community members to the second floor of the building which, for the community, houses the city's Public Library Branch and a Community Health Clinic.

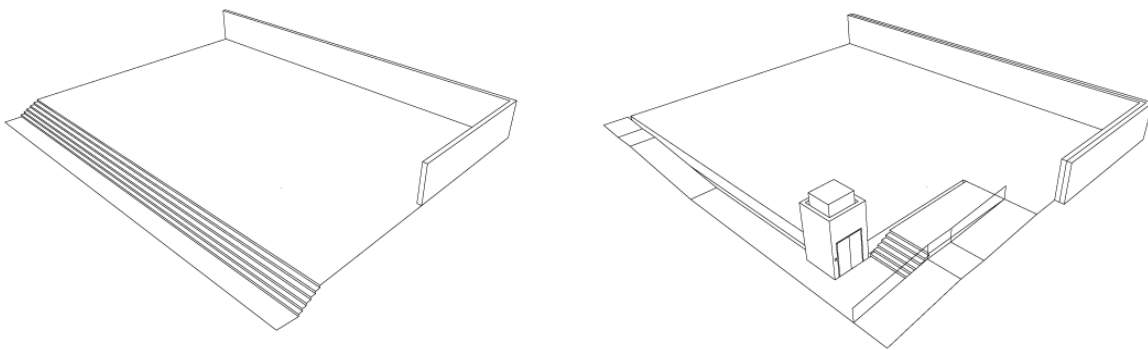

Figure 18: Accessibility. Current condition (left) and intervention of wide 1/12 ramps and an elevator (right).

As an intervention to the school's current lack of accessibility four wide ramps are proposed throughout the school building. The 7'6" wide 1/12 ramps are intended to serve as the primary means of navigating this elevation change, so as not to belittle students or teachers using wheelchairs. The ramps are positioned so that students and teachers with mobility issues can easily access all parts of the first floor area. An elevator provides access to the school's second floor and cafeteria. A separate elevator provides access to the Community Center.

Exterior

In the 2006 Community Center Design Workshop participants stated they wished for 'welcoming entrances' and 'accessibility to the upper level [of the community center] without heavy-handed ramps.' All of the teams also advocated for the removal of the ramps.

The exterior interventions include removing the ramps and adding to internal fire protected staircases at the Brackett Street and Clark Street sides of the building. Integrated seating was added at both the Brackett and Clark Street entrances for students and community members to use.

The Brackett Street entrance to the school was pulled towards the street in order to create an area to screen and badge visitors entering the school. A tensile fabric structure was also added at the Brackett

Street entrance to provide shelter and students waiting for their parents, to make the space more inviting and to help signal its prominence as the school’s primary entrance.

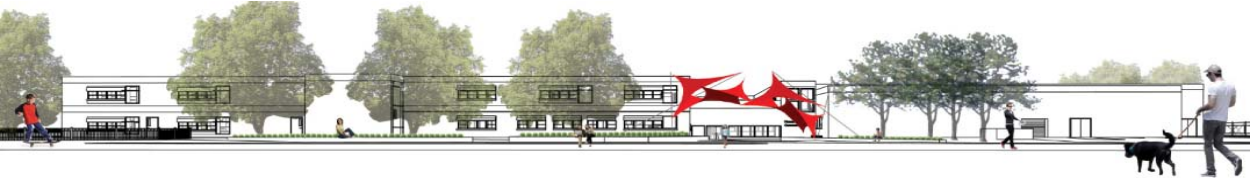

Figure 19: Proposed Brackett Street Perspective

Integrated benches and raised beds for vegetation were added along the pathway from Brackett Street to the Community Center (behind the gym) to help engage this façade. Strategically placed site lighting would help ensure the security of this location after dark. The building’s garbage bins have been relocated to the Brackett Street service area, where they were originally intended.

A new Community Center entrance welcomes community members who are visiting the library, health clinic, gym or pool. A living wall has also been added along the exterior of the pool and locker rooms providing an area of lush vegetative growth to break up the hard surfaces of the parking lot and building façade within this urban environment.



Figure 20: Proposed Community Center Entrance

Classrooms

Interior walls have been added throughout the school to help control acoustics within the building and specifically within the classrooms. In order to address the current classroom’s lack of storage, casework has been added along the exterior wall and the wall facing the interior hallway to provide much needed storage. The casework also conceals the heating ducts and other services supporting the classroom.



Figure 21: Interior classroom perspective. Illustrating casework and HVAC system above windows.

Each classroom also has a built-in window seat along the exterior wall of the classroom which is integrated into the thick wall system. This provides students with a place to curl up with a book to read and observe the world outside.

In order to maintain a sense of visual connection to the building's interior a long window facing the building's hallway allows students walking outside classrooms the opportunity to see what their siblings and friends are doing. The windows also provide an opportunity for teachers to monitor the school's hallways. These interior windows have a 3' sill height so students seated for instruction are less likely to be distracted by activity in the hallway. The exterior windows are lower, with a sill height of 2'6" and the window seat has a height of 14" to provide students' views to the exterior while seated.



Figure 22: Proposed classroom windows. Exterior view (left) and interior view (right).

The exterior window heights meet LEED the IEQ Credit 8.2 requirements of achieving a direct line of sight to the outdoor environment between 30" and 7'6" above the finish floor for building occupants. The classroom's remaining two walls house white boards and bulletin boards for displaying artwork, posters and inspirational quotes.

In keeping with the school's current practice, student coats are stored outside of the classrooms on coat hooks. This helps relieve space within the classrooms and creates a space for informal interactions between students and different classes before and after recess.

The kindergarten classrooms are clustered in the quiet northeastern portion of the school with direct access to the playground. A space called the 'kindergarten reading area' has been designed adjacent to the classrooms where kindergarteners and their senior or 5th grade reading buddies can practice reading and other important skills in integrated seats. While the space is on the interior of the building it is lit by natural light via solatubes.



Figure 23: Kindergarten reading area

Two English Language Learner (ELL) classrooms are housed on the second floor of the building across from ELL-designated Ed. Techs. who help provide Reiche's newest students with much needed support.

The second floor also houses a number of small instructional spaces where Ed. Techs. or community volunteers can work with small groups of students who need additional help in subjects like math and reading. The learning that takes place in these small groups is vital to helping students who are struggling catch up to their peers.

As part of the intervention proposal the Community Health Clinic was moved out of the school side of the building to the location of the old music room. The music room was in turn moved to the school side of the building. The new music room provides space for band or symphony practice, general music instruction and ample storage space for sheet music as well as student and school instruments. The instrument storage room also doubles as a practice room where a small group of instrumentalists may go to practice a difficult piece during rehearsal.

Two designated Functional Life Skills (FLS) classrooms have also been added to the building in the area which previously housed the Community Health Clinic. Adjacent to the FLS classrooms is an OT/PT classroom. These rooms are adjacent to the offices of Ed. Techs. who provide these students specialized support.

Each floor has a centralized recycling area for 50 gallon paper recycling bins and can and bottle collection to encourage recycling.

Windows

Throughout the building the windows have been enlarged to provide students with views out of their classroom to the exterior. The windows to the exterior are 30" (2'6") in height and the windows facing the interior hallways are 36" (3') high. The exterior window configuration includes 4 double-hung 36"x36"

windows with a 30" sill height and a fixed 6'3" x 4'6" window with an integrated light shelf and sill height of 14". This configuration provides each classroom with 64 ft² of glazing out of an approximately 270 ft² exterior wall area, for a glazing to wall ratio of just under 24%.

A window pattern along the pool's south façade mimics the waves within and provides passers by a glimpse at the swimmers. The second floor classrooms are lit with natural lighting via solatubes as are the gymnasium, auditorium, libraries, and pool.

Lunchroom

The cafetorium/lobby area at the entrance of the building currently poses a security risk for students and reduced the ability of the auditorium space for other functions due to the time needed to setup and breakdown the lunchroom space each day.

By moving the lunchroom into the interior of the school the auditorium can be used by classes practicing a play, or on a particularly stormy day for a breakout recess space. Likewise, the lunchroom, with tables that fold into the walls can be used by classes and students during off hours.

A ramp is provided off the Clark Street entrance for food service personnel to bring food into the building, since all food in the Portland Public School District is prepared at a central location and brought to the site each day. The cafeteria is configured so that rolling refrigerated and heated carts can be wheeled inside and distributed by kitchen staff directly to the students. A small janitorial closet near the kitchen provides space for cleaning supplies to mop up messes and designated space on either side of the lunchroom's exit provides space for recycling, composting, tray and silverware collection.



Figure 24: Library Perspective

Library

The library is one of the most important spaces at a school. Reading is a fundamental skill that all students must master in order to be successful in life and school. Reading allows students to explore new topics, escape from their troubles and find adventure and wonder. To a reader, the library becomes the center of all knowledge.

The renovation preserves the open feel the library as it was originally intended by its designers. It creates captured spaces for students to huddle down with a good book as an individual or with their class during reading time. The plan further defines the library's art gallery and encloses the small auditorium adjacent to the library for better sound attenuation. The art gallery and library are lit via natural light via solatubes.

Community Center

Currently, the entrance to the community center is almost undistinguishable; it is a single orange door at the back of the building near the gymnasium and pool with a small metal sign. As a result, many community members enter the Brackett and Clark Street entrances shared with the school. This places students at a safety risk and creates an awkward situation for community members who might inadvertently walk into a performance in the auditorium or a food fight at lunch.



Figure 25: Existing Community Center Entrance.

The proposed intervention creates a designated and prominent entrance for the community adjacent to the parking lot on Clark Street, maintaining pedestrian access from Brackett Street (illustrated in figure 20). The intervention also creates a number of multi-purpose meeting spaces that could be used for book group meetings, neighborhood association meetings and PTA meetings. It creates a library terrace, community garden bridging the space between the school and the

community center and provides space to house the City of Portland's after-school program which is currently run out of a storage room adjacent to the cafetorium.

Material Selection and Mechanical Services

The selection of materials and mechanical components is imperative to helping the school achieve its energy saving and sustainability goals. The simple specification of high albedo, permeable hardscape surfaces not only reduces stress on the sewer system, but the urban heat island effect, which in turn improves air quality thereby reducing symptoms of respiratory disease.

Envelope

Increasing the R-value of the building envelope provides the best opportunity for the school to reduce its dependence on fossil fuels and shield itself from volatile fuel prices. This allows the School District to spend more of its resources on educating its students. Currently, the school's exterior envelope is 12" thick and

comprises of a brick and concrete masonry unit (CMU) with drywall on the interior. This system has an R-value of less than 2 (assuming the brick is .44, the CMU is .45, and the drywall is .45). In order to increase the R-value of the building's shell it is suggested that the walls be stripped down to the CMU and insulated from the interior.

The application of 5" of Expanded Polystyrene (EPS) insulation would increase the R-value of the envelope by 20 R (Insulation Technology Inc, 2010). The energy savings alone from increasing the R-value of the walls and roofs to 20 R would save the district enough money to pay for itself in several years.

The interior of the envelope would be framed with a cold-formed light-gauge steel framing product with a high percentage of recycled material. A gap between the spray foam insulation and the framing would provide an effective thermal break for the system. The interior side of the envelope will be finished with ½" drywall which meets LEED's IEQ credit 4.6.

The resulting exterior wall envelope would have an R-value of 20 and be 17.5" thick. Not only will this system dramatically reduce the School District's heating needs but it will also dramatically reduce noise pollution from the surrounding neighborhood which is important because the school is close to the Portland International Jetport's flight pattern (Portland International Jetport, 2009).

The roof of the building is another critical area lacking adequate insulation. The thermal envelope of the building also extends to the roof. With the coffered ceiling and no crawl space, there is no room to insulate the ceiling from the interior. An inverted roof, common in European countries, would be an effective solution to insulating the roof. An inverted roof applies insulation on the exterior of the roof structure above the waterproof membrane layer instead of below the membrane layer as in traditional construction. Dow Building Solutions manufactures an inverted roofing system, the ROOFMATE MⁱⁿK system (2010), which provides an R-value of 6.67 for their 200 mm (7.78") assembly. The structure must support an added load of 16.5 PSF imposed by the ballasted system. It is important that the ballasted system be high-albedo with high infrared emissivity in order to reduce the heat-island effect of the building on the environment. Not only will this help reduce the heat-island effect, but it also reduces heat transfer into the building, therefore reducing air conditioning costs.

Fenestrations

Providing energy-efficient fenestrations is extremely important in order for the project to achieve its energy efficiency goals. The return on investment of upgrading the building's windows to triple glazed windows as opposed to double glazed windows should be thoroughly modeled in an energy analysis software program during the design phase.

Artificial lights should be controlled via a dual motion/daylighting sensor so that in sunny conditions lights are dimmed or turned off and during cloudy days the lights are turned on.

Solatube's model 330 DS-O Open Ceiling (21 in/530 mm Daylighting System with OptiView Diffusers) could be used on the 2nd floor of the building (in classrooms, the library and health center) to save energy and provide daylighting with a high R-value (Solatube, 2010). Solatubes are also built into several walls on the 2nd floor to bring natural light to the first floor's kindergarten reading area, the school's art gallery and the hallway of the community center.

This technology is also recognized by LEED as contributing to ID Credit 3, School as a Teaching Tool (Solatube, 2010), by allowing students to learn about daylighting and monitors the product's performance. Solatube products have also been effective in pool and gymnasium applications and will be used in this capacity as well to reduce energy consumption. In the gymnasium and pool areas the Solatube SolaMaster

Series 148 Sola tube 750 DS (21 in/530 mm) Daylighting system is proposed used with OptiView Open Ceiling Diffusers.

Flooring

Resiliency is the most important feature of the school's flooring. The flooring must be able to endure heavy traffic and use for many years. It is also important that the surface be allergy friendly, easy to clean and meet the requirements of LEED IEQ credit 4.3. Marmoleum Decibel, a natural linoleum, is proposed for the project. This product provides sound attenuation in addition to an allergen friendly and easy to clean surface. The product reduces sound impacts by 17 dB (Forbo, 2010).

In order to prevent pollutants from entering the building a product like Forbo Nuway's Entrance Grid should be installed at all entrances to the building. This particular system can help remove 90% of pollutants and reduce maintenance costs on floors (Forbo, 2010). The specifications of this system's installation should meet the requirements of LEED IEQ credit 5.

Wall Products and Casework

Forbo bulletin boards are proposed to compliment the school's flooring selection. These bulletin boards can be wiped clean with a damp cloth, are permanently bactericidal and can help earn the project LEED credits due to its post-industrial recycled content and rapidly renewable ingredients (Forbo, 2010). All paints and coatings should meet the California Department of Health Services Standard Practice for the Testing of Volatile Organic Emissions from Various Sources Using Small-Scale Environmental Chambers, including 2004 Addenda, as required by LEED IEQ Credit 4.2. The casework for storage in classrooms should be constructed out of formaldehyde-free FSC Certified plywood, and finished to meet the requirements of LEED's IEQ Credit 4.4.

Site Considerations

Reducing stormwater runoff is important in protecting Portland's nearby Casco Bay. Rainwater should be collected from the building's roof for use in toilet flushing. All parking lots and asphalt surfaces should be replaced with permeable and high albedo pavement in order to help meet LEED SS Credits 6.2 and 7.1. In addition to reducing runoff the pavement will also reflect reduce the urban heat island effect. During winter months, permeable pavement also reduces ice on walking surfaces because during the daytime snow melt is absorbed into the ground before it freezes again at night, reducing maintenance costs.

Site lighting is important for Reiche School because the building is used during evening hours after dark. The site is known in the neighborhood as a haven of drug and petty criminal activity after dark. An effective lighting plan will help reduce the chances of these activities taking place and will help neighborhood residents feel safer around the school at night. All exterior lighting fixtures for the school should be energy-efficient and dark-sky compliant meeting the requirements of LEED SS Credit 8. This will allow the children of Reiche to have a better chance of seeing stars off their balconies at night.

Heating, Ventilation and Air Conditioning

The building's scheme relies largely on user controlled windows. However, since the school is located in an urban environment which can be noisy at times, a forced air heating and cooling system is proposed which can be controlled by users in their classrooms in accordance with LEED credit 6.2. In the proposed system, air would be pre-heated by a ground-source heat pump located beneath the parking lot on Brackett Street, adjacent to the boiler room. This will help the project meet LEED Credit EA 2. A heat recovery ventilator is also proposed to reduce the amount of air that must be heated in the system. Forced air was selected over radiant heating or radiators because air passing through the system can be easily treated to kill germs and bacteria via ultra-violet radiation. This treatment has proven to dramatically reduce illness and infection

rates in hospital settings and according to a National Research Council Report, and could provide the same level of success in a school setting (National Research Council, 2007). When embedded in a forced air system the side-effects of exposing students directly to the light are eliminated. This system would reduce absenteeism among students and teachers, thus providing more contact time for students to learn new skills.

Safety and Access

School access and safety are very important, especially considering the school is located in an urban area and its grounds and facility are shared by the community during school hours. The plan calls for a student entrances (on either side of the lobby) which are access-controlled via the receptionist during school hours. Other exterior doors, such as the one leading to the playground could be controlled via electronic keycards worn by supervising teachers. A benefit of this technology is that in the case of an attack, cards can quickly and easily be disabled without requiring the rekeying of doors (Schneider, 2010).

The Community Center Entrance near the pool and gym, off of Clark Street is designed to house the Community Center Administrator or a receptionist who can greet members of the community who are visiting the school. A roll-down door would secure the reception area during unstaffed hours. The proposal also advocates that the Community Center has a designated elevator.

Before school hours both the Brackett Street and Clark Street entrances (Clark Street houses the bus drop-off area) could remain unlocked. During school hours the Brackett Street entrance would serve as the single point of access for outsiders to access the school. The Brackett Street entrance is designed to contain visitor traffic for screening and badging prior to entering the lobby/auditorium area. This is an important improvement because it would protect students who may be gathered for an assembly in the auditorium off the current lobby area. Currently, visitors have access to the assembly/lunchroom space prior to being badged and checked in by the school's receptionist which presents an unnecessary security risk to the students. Visitors can be screened by the receptionist using the state's sex offender registry and school-maintained databases prior to unlocking the door leading into the school. From the receptionists desk various security cameras placed around the school's exterior can also be monitored for signs of unusual activity. It is important to ensure that the electronic access systems have an emergency power back-up system in the case of a power failure, as recommended by the National Clearinghouse for Educational Facilities (Schneider, 2010).

An important addition sorely needed by the school is a public address system that can double as an emergency communication system which allows an administrator at the school to contact either individual classrooms or notify the whole school of a pending threat. It is also important that this system allows teachers the option of contacting administrators directly in the case of an emergency without having to leave their students. The National Clearinghouse for Educational Facilities stresses that it is important to ensure that all areas of the school are serviced by the communication system including: the playground, bathrooms, boiler rooms. This system could easily be housed in the casework chase within the classrooms.

Transportation and Site Circulation

While the majority of Reiche's students walk to school, providing adequate bicycle storage racks at the school is important. The proposal locates bike racks at the school's Brackett Street entrance, Clark Street Entrance and at the Community Center entrance. A small bike rack would also be installed near the playground to primarily serve weekend and afterschool visitors. These bike racks help the school meet LEED SS credit 4.2.

The transportation patterns of the school remain the same as the pre-renovation plan in the proposal. The buses park on Clark Street and students are able to enter the school via the Clark Street entrance before

school hours and parents dropping off their children via car can pull through a drop-off area on Brackett Street. Parents can also wait for their children at the end of the school day inside at the Brackett Street entrance without being badged.

Conclusion

The Howard C. Reiche Community School is a great asset to Portland's West End neighborhood. The school not only provides a safe place for students to learn, grow, and play but is also a place for their parents and neighbors to gather as well.

The building stands to benefit substantially from the addition of insulation, ramps for accessibility, interior walls with casework for storage, enlarged windows that provide students a visual connection to the building's exterior, and more prominent entrances. These simple interventions stand to greatly increase the functionality and usability of the school and community center for years to come.

References

- Dow Building Solutions (2010). The ROOFMATE MⁱⁿK system, <http://building.dow.com/europe/uk/ins/invert/bal/mink.htm> (March 21, 2010).
- Forbo, 2010. Forbo Bulletin Board, <http://www.forboflooringna.com/DesktopModules/image.aspx?id=207&t=dl&ot=qckdl&chc=-739172944&ext=.pdf> (March 21, 2010).
- Forbo, 2010. Forbo Entrance Systems, www.forboflooringna.com/DesktopModules/image.aspx?id=350&t=dl&ot=qckdl&chc=1877587246&ext=.pdf (March 21, 2010).
- Forbo (2010). M A R M O L E U M[®] D E C I B E L Technical Data Sheet, <http://www.forboflooringna.com/DesktopModules/image.aspx?id=802&t=dl&ot=docdctr&chc=380618736&ext=.pdf> (March 21, 2010).
- Insulation Technology Inc. (2010). EPS Insulation, www.insultech-eps.com/insulation.html (March 21, 2010).
- National Research Council (2007). Green Schools: Attributes for Health and Learning, 116-118.
- New England School Development Council (2009). Long-Range School Facilities Planning, Portland, Maine. April 2009, 4, 8, 10, 17, 31.
- Portland International Jetport (2009). Aircraft Noise and Flight Monitoring System: Harbor Visible Flight Tracks, www.portlandjetport.org/NOISE.ASP (June 14, 2009).
- Schneider, Todd (2010). National Clearinghouse for Educational Facilities, School Security Technologies, 2-8.
- Solatubes (2010). Solatube 330 DS-O Open Ceiling (21 in/530 mm Daylighting System), http://www.solatube.com/Residential/Professionals/Technical-Resources/asset_upload_file796_3472.pdf (March 21, 2010).
- Solatube (2010). Solatube Products and LEED 2009, <http://www.solatube.com/commercial/daylighting/solatube-leed/index.php> (March 21, 2010).

RE-THINKING THE HOWARD C. REICHE COMMUNITY SCHOOL

A RENOVATION PROPOSAL FOR AN URBAN, OPEN-PLAN ELEMENTARY SCHOOL AND COMMUNITY CENTER IN THE HEART OF PORTLAND, MAINE'S HISTORIC WEST END NEIGHBORHOOD REICHE IS A SPACE FOR THE COMMUNITY TO LEARN, GATHER, AND PLAY



THE BRACKETT STREET NEIGHBORHOOD

ON A SUNNY AFTERNOON STUDENTS FROM THE HOWARD C. REICHE COMMUNITY SCHOOL SPILL OUT OF THE SCHOOL'S DOORS AND INTO THE NEIGHBORHOOD. STUDENTS CAN BE FOUND LINED UP OUTSIDE OF THE CUMBERLAND FARMS BUYING SLUSHIES AND ICE CREAM AND AT FRESH APPROACH WHERE THEY BUY BASEBALL-SIZE WHOOPIE PIES.

STUDENTS WALK HOME IN PAIRS OR GROUPS CARRYING VIOLINS, BOUNCING BALLS AND SPORTING COLORFUL BACKPACKS. THEY ARE HEAVY IN CONVERSATION.

CHILDREN SWING ON SWINGS AND RIDE BIKES IN REICHE'S PLAYGROUND JOINED BY YOUNGER SIBLINGS AND THEIR PARENTS. NEARBY, TEENAGERS SHOOT HOOPS AT THE BASKETBALL COURT ON BRACKETT STREET.

ALICE IS MAKING ROUNDS COLLECTING CANS FROM MULTI-FAMILY RECYCLING BINS. SHE KNOWS JUST WHERE TO LOOK AND RECEIVES WARM GREETINGS FROM TENANTS AND HOMEOWNERS.

IN THE EVENING COMMUNITY MEMBERS WALK TO THE COMMUNITY CENTER TO SWIM, VISIT THE COMMUNITY LIBRARY BRANCH OR PARTICIPATE IN AN INDOOR BASKETBALL GAME. THE WEST END NEIGHBORHOOD ASSOCIATION TALKS ABOUT CRIME TRENDS IN THE NEIGHBORHOOD AND PLANS FOR ITS NEXT FREE MOVIE NIGHT AT THE COMMUNITY CENTER.

THE SIDEWALKS AND STREETS ARE CONSTANTLY FULL OF PEOPLE AS DOGS WALK THEIR OWNERS AND PEOPLE JOG OR TAKE AN EVENING STROLL WITH FAMILY MEMBERS.

IN A TWO-BLOCK RADIUS OF REICHE (LESS THAN 1/4 MILE) YOU CAN BUY LOCALLY GROWN PRODUCE AND GROCERIES AT FRESH APPROACH, GAS AT THE CUMBERLAND FARMS, GRAB A SLICE OF WOOD-FIRED PIZZA AT BONOBO, OR HAVE AN INTIMATE DINNER AT CAIOLAS. IF YOU NEED STITCHES MERCY HOSPITAL IS JUST AROUND THE CORNER. YOU CAN EVEN TAKE FIDO OR FLUFFY FOR ACUPUNCTURE AT THE BRACKETT STREET ANIMAL CLINIC.

1. CUMBERLAND FARMS (GROCERIES AND GAS)
2. BONOBO'S (WOOD OVEN FIRED PIZZA)
3. BRACKETT STREET VETERINARY CLINIC
4. PERCY INN (BED AND BREAKFAST)
5. CONROY-TULLY CRAWFORD FUNERAL HOME
6. PORTLAND CLUB (SOCIAL CLUB, RESTAURANT)
7. MERCY HOSPITAL
8. PORTLAND WEST (AFTER SCHOOL TUTORS)
9. FRESH APPROACH (WORKING MANS GROCERY)
10. GHINO CAFE
11. VARIOUS PROFESSIONAL OFFICES
12. SOAP BUBBLE LAUNDRY AND DRY CLEANING
13. AURORA PROVISIONS (CAFE, GROCERIES, PREPARED FOODS)
14. CAIOLAS (FINE DINING)
15. MAINE MEDICAL CENTER OFFICES
16. RONALD MCDONALD HOUSE

EDUCATIONAL PHILOSOPHY

LEARNING TAKES PLACE IN MANY FORMS, HAS MANY TEACHERS, AND OCCURS IN MANY PLACES. FROM THE PLAYGROUND, TO THE NEIGHBORHOOD GROCERY STORE, IN THE LIBRARY AND THE CLASSROOM STUDENTS ARE CONSTANTLY SOAKING UP KNOWLEDGE AND GAINING NEW LIFE EXPERIENCES. IT TAKES A COMMUNITY TO RAISE A CHILD, AND FOR STUDENTS AT THE HOWARD C. REICHE COMMUNITY SCHOOL, THIS COULD NOT BE MORE TRUE.

PROGRAM

THE BUILDING SHOULD REDUCE THE DISTRICT'S DEPENDENCE ON FOSSIL FUELS, BE A MODEL OF SUSTAINABLE DESIGN PRINCIPLES AND TOOL FOR EDUCATORS.

THE SCHOOL SHOULD ALLOW STUDENTS AND TEACHERS TO FOCUS ON LEARNING. THE COMMUNITY CENTER SHOULD WELCOME VISITORS AND PROVIDE SPACES TO RECREATE AND LEARN - BOTH INSIDE AND OUT.

SCHOOL

18 CLASSROOMS
MUSIC ROOM
SUPPORT (ELL, FLS)
LIBRARY
ADMINISTRATIVE OFFICES
LUNCHROOM

SHARED

POOL
GYM
AUDITORIUM
LOBBY
PLAYGROUND
PLAYING FIELD
BASKETBALL COURT
BUILDING SERVICES
LOADING DOCK

COMMUNITY

LIBRARY BRANCH
ADMINISTRATIVE OFFICES
HEALTH CLINIC
COMMUNITY ENTRANCE
COMMUNITY PARKING

WHO ARE THE STUDENTS?



50% BORN OUTSIDE OF THE UNITED STATES
48 COUNTRIES REPRESENTED & 28 LANGUAGES SPOKEN
12% IN ENGLISH LANGUAGE LEARNER (ELL) CLASSES
89% QUALIFY FOR FREE OR REDUCED LUNCHES
90% WALK OR CYCLE TO SCHOOL

CURRENT CONDITIONS - OPEN PLAN INTERIOR

- OFFICE PARTITION WALLS BETWEEN CLASSROOMS
 - CREATE ACOUSTICAL PROBLEMS
 - EASY TO CONFIGURE BUILDING LAYOUT TO MEET NEEDS
- NO STORAGE FOR TEACHERS
- SECURITY ISSUES
 - OPEN PLAN AND MULTIPLE ENTRANCES
 - MULTIPLE USERS
- NO VIEWS OUT OR DAYLIGHT FOR INTERIOR CLASSROOMS
- MULTIPLE LEVELS AND NO ELEVATOR/RAMPS = INACCESSIBILITY
- DIFFICULT TO MANAGE HEATING AND COOLING NEEDS
- UNINVITING EXTERIOR
- LACK OF PROMINENT COMMUNITY CENTER ENTRANCE



LIBRARY



CLASSROOM W/PARTITIONS
NO OUTSIDE VIEWS OR STORAGE



LOBBY / LUNCHROOM

	AREA	CHALLENGE	PROPOSED INTERVENTION
A	CLASSROOMS	LACK OF STORAGE, VIEWS, ACOUSTICS. INACCESSIBLE	MOVE CLASSROOMS TO EXTERIOR AND SUPPORT SERVICES TO INTERIOR. ENLARGE WINDOWS. ADD INTERIOR WALLS. INTEGRATE STORAGE AND HVAC SYSTEMS INTO WALL SYSTEMS. ADD RAMPS.
B	EXTERIOR	UNINVITING, LACK OF CONNECTION TO STREET. WINDOWS DON'T PROVIDE ADEQUATE DAYLIGHT	REDESIGN ENTRANCES, PULL THEM TOWARDS THE STREET. ENLARGE WINDOWS.
C	COMMUNITY CENTER	NO PROMINANT ENTRANCE, LACK OF MEETING SPACES, PROGRAM ON BOTH 'SIDES' OF SCHOOL	ADD PROMINENT ENTRANCE WITH RECEPTION/ADMINISTRATION AREA. ADD MEETING ROOMS, SHIFT COMMUNITY CENTER ACTIVITIES TO COMMUNITY CENTER SIDE OF SCHOOL.
D	LIBRARY	NO DEFINED SPACE FOR SUPPORT STAFF, CLASSES	CREATE CAPTURED SPACES FOR READING, PLAYING, AND WORKING.

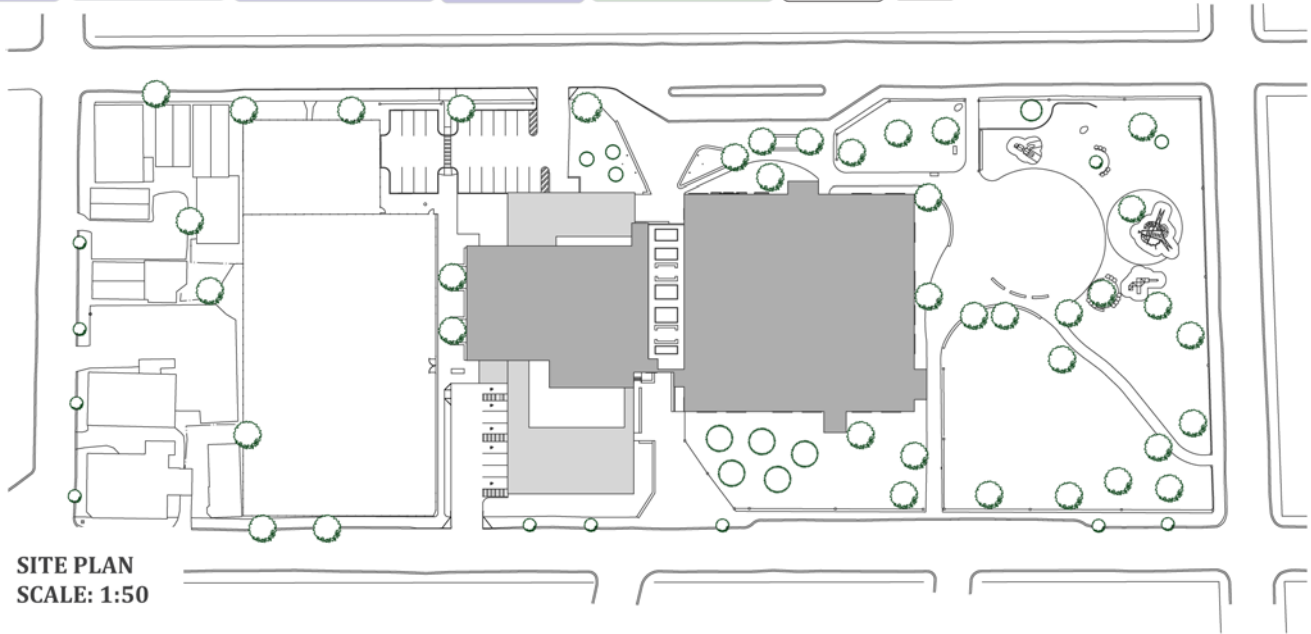
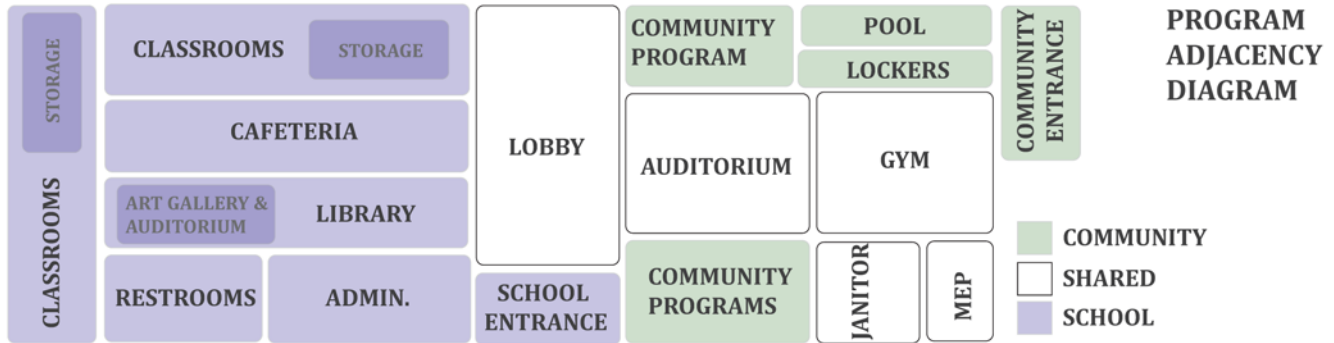

A CLASSROOM DESIGN OBJECTIVES

INTERVENTION: ADD WALLS TO IMPROVE ATTENTION SPANS AND ACOUSTICS.

INTEGRATE STORAGE AND HVAC IN WALLS TO REDUCE CLUTTER AND CONTROL OCCUPANT COMFORT.

PROVIDE VIEWS IN AND OUT OF ROOMS VIA WINDOWS. CONTROL SIGHT LINES TO FOSTER CONCENTRATION DURING INSTRUCTION.

36" WINDOW ALLOWS STUDENTS TO SEE OUT WHILE STANDING BUT NOT DURING SEATED INSTRUCTION

HVAC INTEGRATED IN CASEWORK

30" WINDOWS FOR LOOKING OUT WITH CASEWORK SURROUNDING

SEAT FOR READING



**STARTING POINT
CHALLENGES**

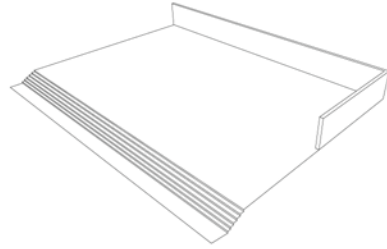

ENERGY INEFFICIENT, POOR ACOUSTICS, LACK OF STORAGE, NOT ACCESSIBLE, LACK OF DAY-LIGHT AND VIEWS

**1
ENERGY
EFFICIENCY**

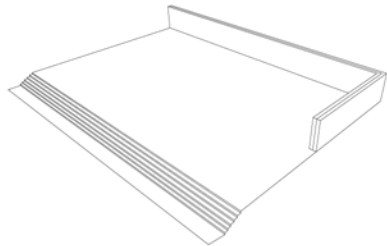

TO INCREASE THE BUILDING'S ENERGY EFFICIENCY ADD INSULATION ON THE BUILDING'S INTERIOR.

**2
ACCESSIBILITY**

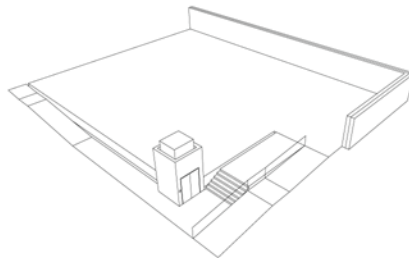

ADD 1/12 RAMPS AND AN ELEVATOR TO MAKE THE BUILDING WELCOMING TO ALL.

**3
ACOUSTICS**

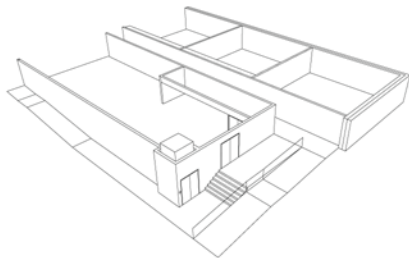

ADD INTERIOR WALLS TO IMPROVE ACOUSTICS AND STUDENT ATTENTION SPANS.

**4
STORAGE / VIEWS**

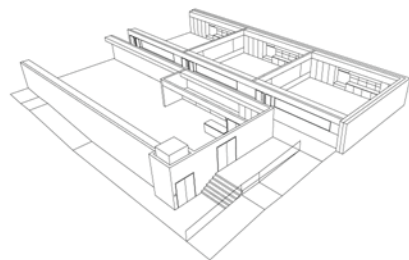

ADD CASEWORK WITH INTEGRATED WINDOWS SO STUDENTS CAN SEE OUT OF THEIR CLASSROOMS AND CONNECT WITH THE WORLD BEYOND AND TEACHERS CAN STORE SUPPLIES WHEN NOT IN USE.

**5
FLEXIBLE FIT OUT**

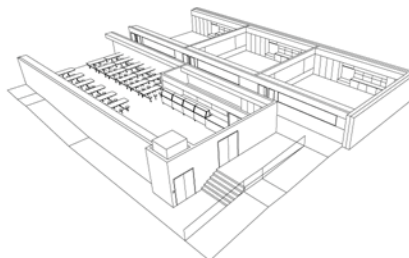

ADD FLEXIBLE, MOVABLE FURNITURE (SUCH AS LUNCH TABLES THAT FOLD INTO THE WALLS) TO ADD FUNCTIONALITY TO SPACES.

- SLEEP
- HOME
- WALK
- PLAY
- LEARN
- EAT / PLAY
- LEARN
- PLAY
- LEARN
- WALK
- HOME

- | | | | | | |
|-----------|------------------|--------------|-------------|--------------|-------------------|
| DO | SEE | LEARN | HEAR | TOUCH | TEACH |
| PLAY | SEAGULLS | TO SPELL | AIRPLANE'S | FLOORS | TEACHERS |
| EAT | SNOW | READ | CARS | WALLS | VOLUNTEERS |
| LEARN | ALLEY CATS | WRITE | LIGHTER | DOORS | LIBRARIANS |
| READ | HOMELESSNESS | DRAW | SHOUTING | CABINETS | SPECIAL ED. TECHS |
| SING | PEOPLE WITH DOGS | PAINT | MUSIC | SINKS | STAFF |
| DANCE | DRINK PEOPLE | COUNTY | TALKING | TOYS | PARENTS |
| LAUGH | PLANTS | MULTIPLY | WHISPERS | BOOKS | PEERS |
| SMILES | FRIENDS | SING | FOOTSTEPS | PENCILS | |
| | | MUSIC | | ROCKS | |
| | | | | DESKS | |

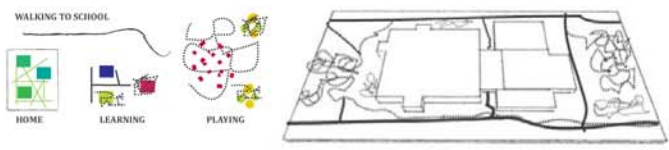

FIRST FLOOR PLAN

INTERVENTION: ADD INTERIOR WALLS AND RAMPS AND ELEVATORS FOR THE COMMUNITY CENTER AND SCHOOL. SEPARATE THE COMMUNITY CENTER AND SCHOOL ENTRANCES. DESIGNATE THE BRACKETT STREET ENTRANCE AS THE SINGLE ACCESS POINT FOR THE SCHOOL.

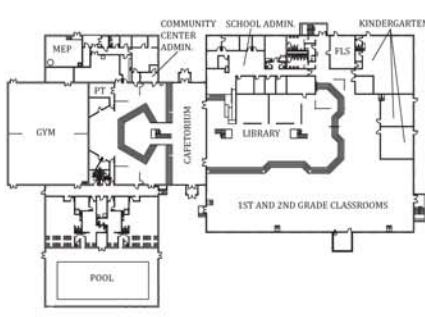

- Room Legend**
- Art Gallery
 - Auditorium
 - Boiler Room
 - Classroom
 - Community Kitchen
 - Gym
 - Janitorial
 - Lobby
 - Locker Room
 - Landscaping
 - Meeting Room
 - Pool
 - Reception
 - Staff
 - Storage
 - Viewing
 - WC



SECOND FLOOR PLAN

INTERVENTION: ADD INTERIOR WALLS. SWAP THE HEALTH CLINIC AND MUSIC ROOMS TO CLEARLY DELINEATE THE PARTS OF THE BUILDING OCCUPIED BY THE SCHOOL AND THE COMMUNITY.

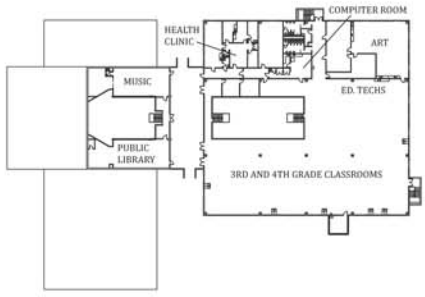

SCALE: 1:30

- Room Legend**
- Art Gallery
 - Auditorium
 - Boiler Room
 - Classroom
 - Community Kitchen
 - Gym
 - Janitorial
 - Lobby
 - Locker Room
 - Landscaping
 - Meeting Room
 - Pool
 - Reception
 - Staff
 - Storage
 - Viewing
 - WC



FRESH APPROACH GROCERY / DELI SOAP BUBBLE LAUNDRY MULTI-FAMILY HOUSING

EDGE CONDITIONS
 REICHE IS LOCATED IN A NATIONAL HISTORIC PRESERVATION DISTRICT IN PORTLAND'S WEST END NEIGHBORHOOD. THE SURROUNDING BUILDINGS ARE 2.5 TO 3 STORIES HIGH AND BUILT IN THE LATE 1800'S. TWO BLOCKS WERE LEVELED BY THE CITY OF PORTLAND TO MAKE WAY FOR THE SCHOOL.

B EXTERIOR - WINDOWS

INTERVENTION: ENLARGE WINDOWS AND IMPROVE ENERGY EFFICIENCY.



PROVIDING DAYLIGHT AND VIEWS. PERSPECTIVES FROM THE INSIDE LOOKING OUT AND OUTSIDE LOOKING IN...

C COMMUNITY CENTER ENTRANCE

INTERVENTION: CREATE PROMINENT ENTRANCE WITH RECEPTION AREA AND ADD VEGETATION AROUND EXTERIOR.



EXISTING WEST FACADE



EXISTING SOUTH FACADE



EXISTING EAST FACADE

B EXTERIOR - BUILDING FACADES

INTERVENTION: REMOVE RAMP ON NORTH AND SOUTH FACADES OF THE BUILDING.

PULL ENTRANCES TOWARDS THE STREET TO WELCOME VISITORS INTO THE SCHOOL.

ADD BUILT-IN SEATING FOR STUDENTS WAITING FOR BUSES OR PICK-UP.

INSULATE EXTERIOR WALLS AND ROOF WITH EXPANDED POLYSTYRENE (EPS) INSULATION TO INCREASE THE BUILDING'S R-VALUE, ITS ENERGY EFFICIENCY AND CLASSROOM ACOUSTICS.

CENTRALLY LOCATE ALL WASTE COLLECTION TO THE BRACKETT STREET SERVICE AREA.



SECTION FACING EAST



WEST FACADE
Facing Playing Fields



NORTH FACADE
Facing Brackett Street



SOUTH FACADE
Facing Clark Street



EAST FACADE
Facing the Playground



SECTION FACING NORTH

A CLASSROOM DESIGN

INTERVENTION: MOVE ALL CLASSROOMS TO THE BUILDING'S EXTERIOR.

ADD WALLS TO IMPROVE PRIVACY AND ACOUSTICS.

ENLARGE WINDOWS TO PROVIDE DAYLIGHTING AND VIEWS.

INTEGRATE STORAGE, SEATING AND HVAC IN CASEWORK.

TEACHING AND DISPLAY SURFACES ON ALTERNATE WALLS.



D LIBRARY

INTERVENTION: CREATE CAPTURED SPACES FOR STUDENTS TO HUDDLE DOWN WITH A GOOD BOOK OR CLASSES TO MEET FOR READING TIME.

DEFINE ART GALLERY AND ENCLOSE SMALL AUDITORIUM FOR BETTER SOUND CONTROL.

CREATE SPACE FOR PUZZLES, PUPPETS, BOOKS, COMPUTERS, STUDENTS TO PLAY AND STAFF TO WORK.



READ TO ME!

READING IS A FUNDAMENTAL SKILL THAT ALL STUDENTS MUST MASTER IN ORDER TO BE SUCCESSFUL IN LIFE.

READING ALLOWS STUDENTS TO EXPLORE NEW TOPICS, ESCAPE FROM THEIR TROUBLES AND FIND ADVENTURE AND WONDER.

TO A READER, THE LIBRARY BECOMES THE CENTER OF ALL KNOWLEDGE. IT IS A PLACE OF WONDER AND EXCITEMENT.

A KINDERGARTEN READING AREA

INTERVENTION: CREATE BUILT-IN SEATING ALONG INTERIOR WALLS OUTSIDE THE KINDERGARTEN CLASSROOMS FOR VOLUNTEERS AND 5TH GRADE READING BUDDIES TO READ WITH STUDENTS. ADD DAYLIGHT VIA SOLATUBES.

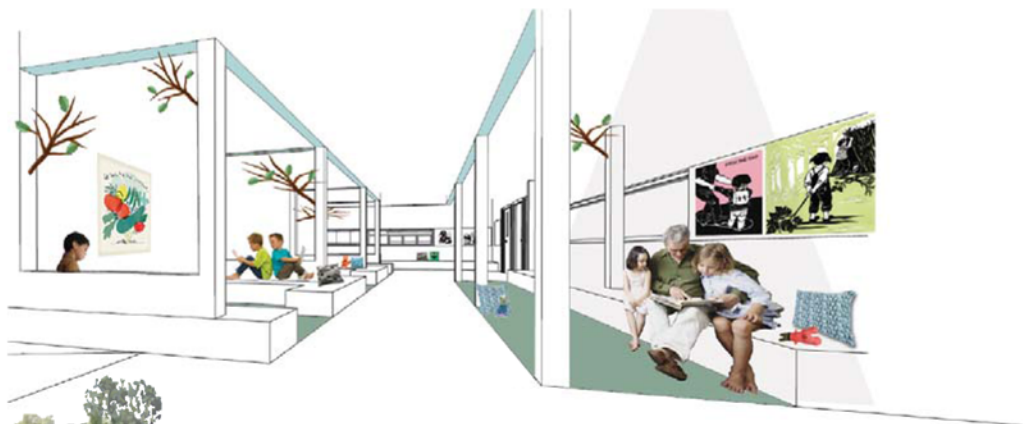

APPENDIX I

SITE PLAN

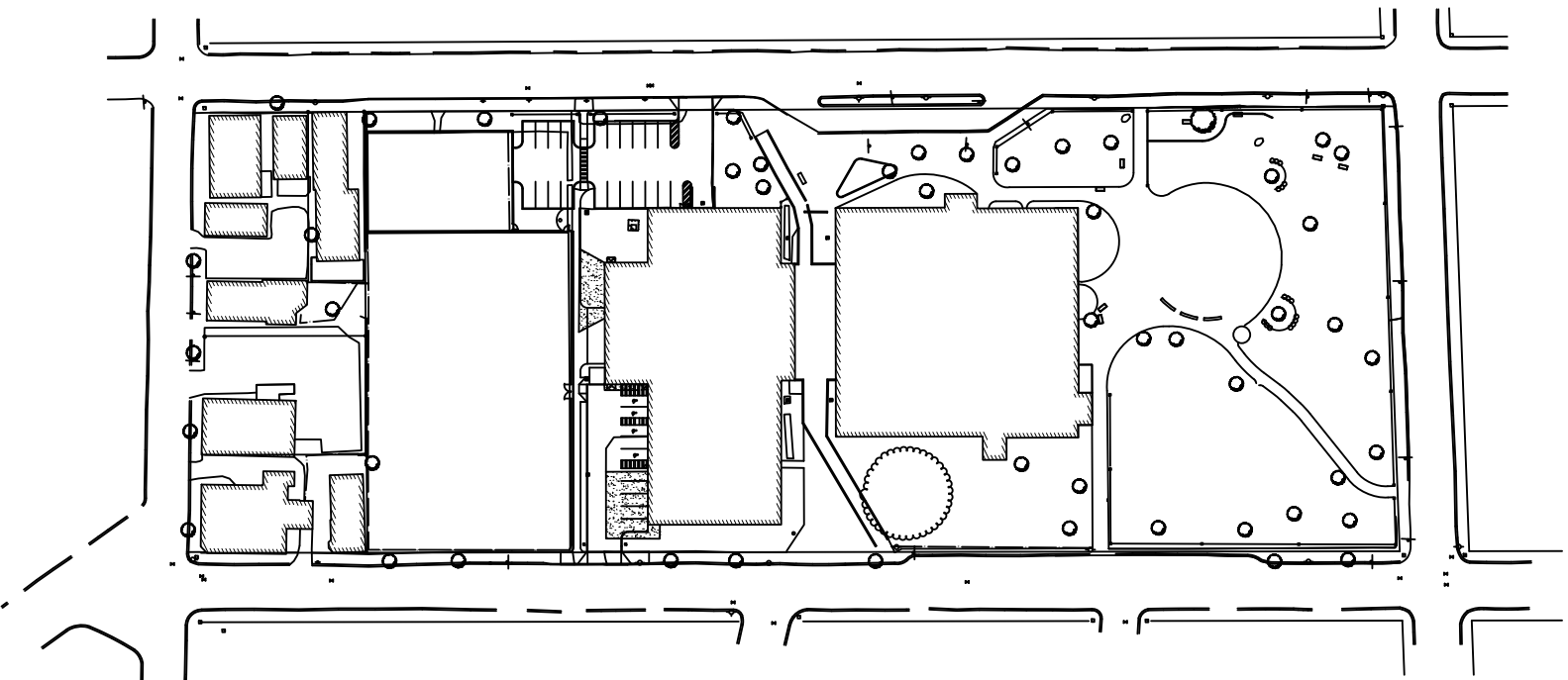

PRESENT SITE CONDITION PHOTOGRPAHS



Site Photos (clockwise from top left):

1) Brackett Street entrance. Ramp at right.

3) Community pool from Clark Street

5) Entrance at the corner of Clark and Spring Streets

7) Playground equipment

2) Clark Street entrance. Ramp at right.

4) Basketball Courts along Brackett Street

6) Playground equipment

APPENDIX III

HISTORIC SITE MAPS I



From 1882 Goodwin's engineering map



1914 Richard's Atlas

APPENDIX IV
HISTORIC SITE MAPS II



Sanborn map (1951)



Present day satellite image

APPENDIX V

INTERIOR PHOTOGRAPHS



Interior Photos (clockwise from top left):

- 1) View of the school library from the top of the second floor staircase. Note room dividers on top floor separating classroom spaces from the hall. Computer stations are located at the back of the library. An student art gallery is located beyond the dividers behind the computers.
- 2) Typical classroom
- 3) First floor lobby/cafeterium. Beyond the glass wall is the school's library.
- 3) Hallway in section of the school with permanent walls.
- 4) Hallway dividing classrooms (at right) on the second level and paraprofessionals' offices (at left).

CURRENT EXTERIOR CONDITION PHOTOGRAPHS



- Exterior Conditions (clockwise from top left):
- 1) Sidewalk from Clark to Brackett Street. Gym at right, fields at left.
 - 2) Outdoor science area and greenhouse
 - 3) Main exterior entrance to the community center off of sidewalk near Clark Street
 - 4) Top of bridge facing Clark Street. School to the left, music room and Community Library at right.
 - 5) Typical exterior elevation on the school side of the building.
 - 6) Loading dock on Brackett Street.



APPENDIX VII
SITE EDGE CONDITIONS



LEED 2009 FOR SCHOOLS NEW CONSTRUCTION AND MAJOR RENOVATION PROJECT CHECKLIST

 LEED 2009 for Schools New Construction and Major Renovation Project Checklist		Howard C. Reiche Community School	
13 Sustainable Sites		Possible Points: 24	
Y	Prereq 1	Construction Activity Pollution Prevention	
Y	Prereq 1	Environmental Site Assessment	
	Credit 1	Site Selection	1
Y	4	Credit 2 Development Density and Community Connectivity	4
	Credit 3	Brownfield Redevelopment	1
Y	1	Credit 4.1 Alternative Transportation—Public Transportation Access	4
Y	1	Credit 4.2 Alternative Transportation—Bicycle Storage and Changing Rooms	1
	Credit 4.3	Alternative Transportation—Low-Emitting and Fuel-Efficient Vehicles	2
	Credit 4.4	Alternative Transportation—Parking Capacity	2
	Credit 5.1	Site Development—Protect or Restore Habitat	1
	Credit 5.2	Site Development—Maximize Open Space	1
Y	1	Credit 6.1 Stormwater Design—Quantity Control	1
Y	1	Credit 6.2 Stormwater Design—Quality Control	1
Y	1	Credit 7.1 Heat Island Effect—Non-roof	1
Y	1	Credit 7.2 Heat Island Effect—Roof	1
Y	1	Credit 8 Light Pollution Reduction	1
Y	1	Credit 9 Site Master Plan	1
Y	1	Credit 10 Joint Use of Facilities	1
6 Water Efficiency		Possible Points: 11	
Y	Prereq 1	Water Use Reduction—20% Reduction	
	Credit 1	Water Efficient Landscaping	2 to 4
Y	2	Credit 2 Innovative Wastewater Technologies	2
Y	4	Credit 3 Water Use Reduction	2 to 4
	Credit 3	Process Water Use Reduction	1
33 Energy and Atmosphere		Possible Points: 33	
Y	Prereq 1	Fundamental Commissioning of Building Energy Systems	
Y	Prereq 2	Minimum Energy Performance	
Y	Prereq 3	Fundamental Refrigerant Management	
Y	19	Credit 1 Optimize Energy Performance	1 to 19
Y	7	Credit 2 On-Site Renewable Energy	1 to 7
Y	2	Credit 3 Enhanced Commissioning	2
Y	1	Credit 4 Enhanced Refrigerant Management	1
Y	2	Credit 5 Measurement and Verification	2
Y	2	Credit 6 Green Power	2
9 Materials and Resources		Possible Points: 13	
Y	Prereq 1	Storage and Collection of Recyclables	
Y	1	Credit 1.1 Building Reuse—Maintain Existing Walls, Floors, and Roof	1 to 2
Y	1	Credit 1.2 Building Reuse—Maintain 50% of Interior Non-Structural Elements	1
Y	2	Credit 2 Construction Waste Management	1 to 2
Materials and Resources, Continued			
Y	1	Credit 3 Materials Reuse	1 to 2
Y	2	Credit 4 Recycled Content	1 to 2
	Credit 5	Regional Materials	1 to 2
Y	1	Credit 6 Rapidly Renewable Materials	1
Y	1	Credit 7 Certified Wood	1
19 Indoor Environmental Quality		Possible Points: 19	
Y	Prereq 1	Minimum Indoor Air Quality Performance	
Y	Prereq 2	Environmental Tobacco Smoke (ETS) Control	
Y	Prereq 3	Minimum Acoustical Performance	
Y	1	Credit 1 Outdoor Air Delivery Monitoring	1
Y	1	Credit 2 Increased Ventilation	1
Y	1	Credit 3.1 Construction IAQ Management Plan—During Construction	1
Y	1	Credit 3.2 Construction IAQ Management Plan—Before Occupancy	1
Y	4	Credit 4 Low-Emitting Materials	1 to 4
Y	1	Credit 5 Indoor Chemical and Pollutant Source Control	1
Y	1	Credit 6.1 Controllability of Systems—Lighting	1
Y	1	Credit 6.2 Controllability of Systems—Thermal Comfort	1
Y	1	Credit 7.1 Thermal Comfort—Design	1
Y	1	Credit 7.2 Thermal Comfort—Verification	1
Y	3	Credit 8.1 Daylight and Views—Daylight	1 to 3
Y	1	Credit 8.2 Daylight and Views—Views	1
Y	1	Credit 9 Enhanced Acoustical Performance	1
Y	1	Credit 10 Mold Prevention	1
2 Innovation and Design Process		Possible Points: 6	
	Credit 1.1	Innovation in Design: Specific Title	1
	Credit 1.2	Innovation in Design: Specific Title	1
	Credit 1.3	Innovation in Design: Specific Title	1
	Credit 1.4	Innovation in Design: Specific Title	1
Y	1	Credit 2 LEED Accredited Professional	1
Y	1	Credit 3 The School as a Teaching Tool	1
3 Regional Priority Credits		Possible Points: 4	
	Credit 1.1	Regional Priority: Specific Credit	1
Y	1	Credit 1.2 Regional Priority: Specific Credit	1
Y	1	Credit 1.3 Regional Priority: Specific Credit	1
Y	1	Credit 1.4 Regional Priority: Specific Credit	1
85 Total		Possible Points: 110	
Certified 40 to 49 points Silver 50 to 59 points Gold 60 to 79 points Platinum 80 to 110			

NEIGHBORHOOD CONTEXT DIAGRAM

THE BRACKETT STREET NEIGHBORHOOD

ON A SUNNY AFTERNOON STUDENTS FROM THE HOWARD C. REICHE COMMUNITY SCHOOL SPILL OUT OF THE SCHOOL'S DOORS AND INTO THE NEIGHBORHOOD. STUDENTS CAN BE FOUND LINED UP OUTSIDE OF THE CUMBERLAND FARMS BUYING SLUSHIES AND ICE CREAM AND AT FRESH APPROACH WHERE THEY BUY BASEBALL-SIZE WHOOPIE PIES.

STUDENTS WALK HOME IN PAIRS OR GROUPS CARRYING VIOLINS, BOUNCING BALLS AND SPORTING COLORFUL BACKPACKS. THEY ARE HEAVY IN CONVERSATION.

CHILDREN SWING ON SWINGS AND RIDE BIKES IN REICHE'S PLAYGROUND JOINED BY YOUNGER SIBLINGS AND THEIR PARENTS. NEARBY, TEENAGERS SHOOT HOOPS AT THE BASKETBALL COURT ON BRACKETT STREET.

ALICE IS MAKING ROUNDS COLLECTING CANS FROM MULTI-FAMILY RECYCLING BINS. SHE KNOWS JUST WHERE TO LOOK AND RECEIVES WARM GREETINGS FROM TENANTS AND HOMEOWNERS.

IN THE EVENING COMMUNITY MEMBERS WALK TO THE COMMUNITY CENTER TO SWIM, VISIT THE COMMUNITY LIBRARY BRANCH OR PARTICIPATE IN AN INDOOR BASKETBALL GAME. THE WEST END NEIGHBORHOOD ASSOCIATION TALKS ABOUT CRIME TRENDS IN THE NEIGHBORHOOD AND PLANS FOR ITS NEXT FREE MOVIE NIGHT AT THE COMMUNITY CENTER.

THE SIDEWALKS AND STREETS ARE CONSTANTLY FULL OF PEOPLE AS DOGS WALK THEIR OWNERS AND PEOPLE JOG OR TAKE AN EVENING STROLL WITH FAMILY MEMBERS.

IN A TWO-BLOCK RADIUS OF REICHE (LESS THAN 1/4 MILE) YOU CAN BUY LOCALLY GROWN PRODUCE AND GROCERIES AT FRESH APPROACH, BUY GAS AT THE CUMBERLAND FARMS, GRAB A SLICE OF PIZZA AT BONOBOS, HAVE AN INTIMATE DINNER AT CAIOLAS. IF YOU NEED STITCHES MERCY HOSPITAL IS JUST AROUND THE CORNER. YOU CAN EVEN TAKE FIDO OR FLUFFY FOR ACUPUNCTURE AT THE BRACKETT STREET ANIMAL HOSPITAL.

1. CUMBERLAND FARMS (GROCERIES AND GAS)
2. BONOBOS (WOOD OVEN FIRED PIZZA)
3. BRACKETT STREET VETERINARY HOSPITAL
4. PERCY INN (BED AND BREAKFAST)
5. CONROYTULLY CRAWFORD FUNERAL HOME
6. PORTLAND CLUB (SOCIAL CLUB, RESTAURANT)
7. MERCY HOSPITAL
8. PORTLAND WEST (AFTER SCHOOL TUTORS)
9. FRESH APPROACH (WORKING MANS GROCERY)
10. OHNO CAFE
11. VARIOUS PROFESSIONAL OFFICES
12. SOAP BUBBLE LAUNDRY AND DRY CLEANING
13. AURORA PROVISIONS (CAFE, GROCERIES, PREPARED FOODS)
14. CAIOLAS (FINE DINING)
15. MAINE MEDICAL CENTER OFFICES
16. RONALD MCDONALD HOUSE



Reiche Neighborhood

MOVEMENT AND ACTIVITY DIAGRAMS

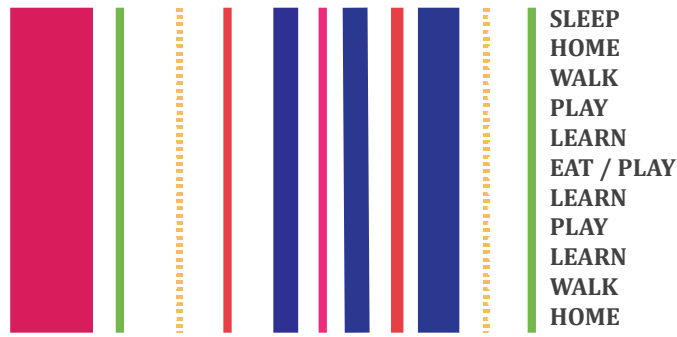

WALKING TO SCHOOL

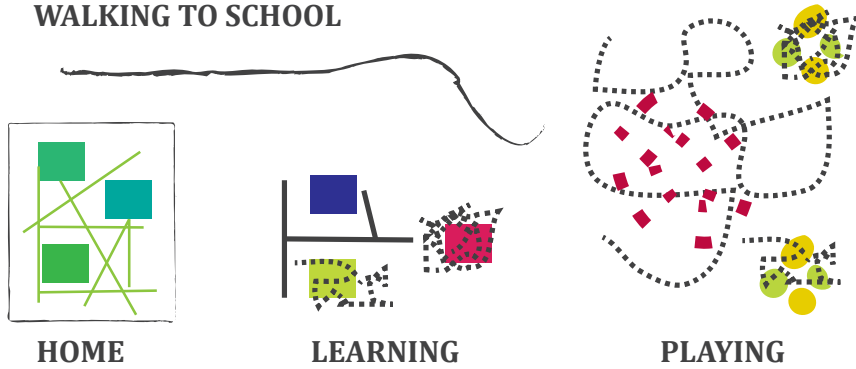

DO	SEE	LEARN	HEAR	TOUCH	TEACH
PLAY	SEAGULLS	TO SPELL	AIRPLANES	FLOORS	TEACHERS
EAT	SNOW	READ	CARS	WALLS	VOLUNTEERS
LEARN	ALLEY CATS	WRITE	LAUGHTER	DOORS	LIBRARIANS
READ	HOMELESSNESS	DRAW	SHOUTING	CABINETS	SPECIAL ED. SPECIALISTS
SING	PEOPLE WITH DOGS	PAINT	MUSIC	SINKS	STAFF
DANCE	DRUNK PEOPLE	COUNT	TALKING	TOYS	PARENTS
LAUGH	PLANTS	MULTIPLY	WHISPERS	BOOKS	PEERS
	SMILES	DIVIDE	FOOTSTEPS	PENCILS	
	FRIENDS	SING		ROCKS	
		MUSIC		DESKS	

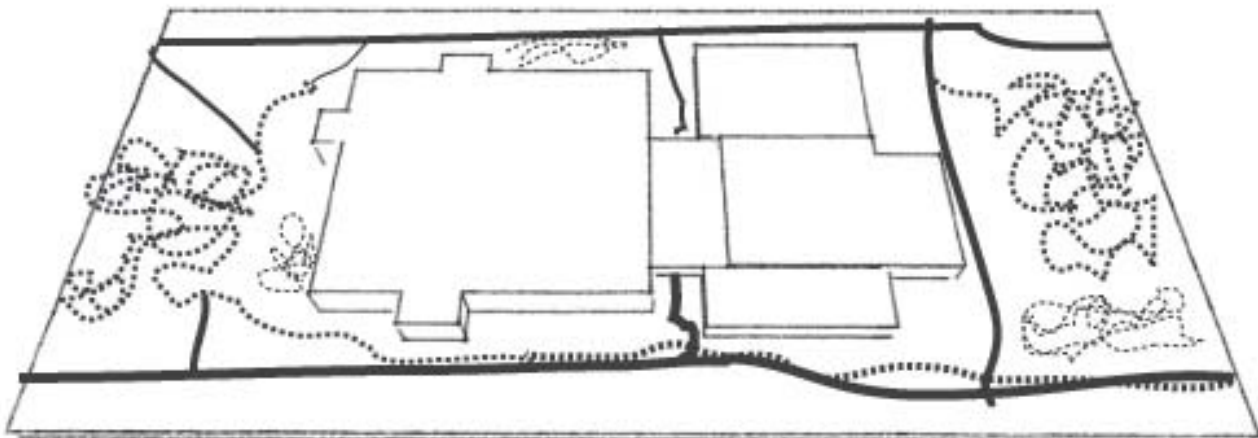

Movement and Activity Diagrams

APPENDIX XI

SITE PLAN

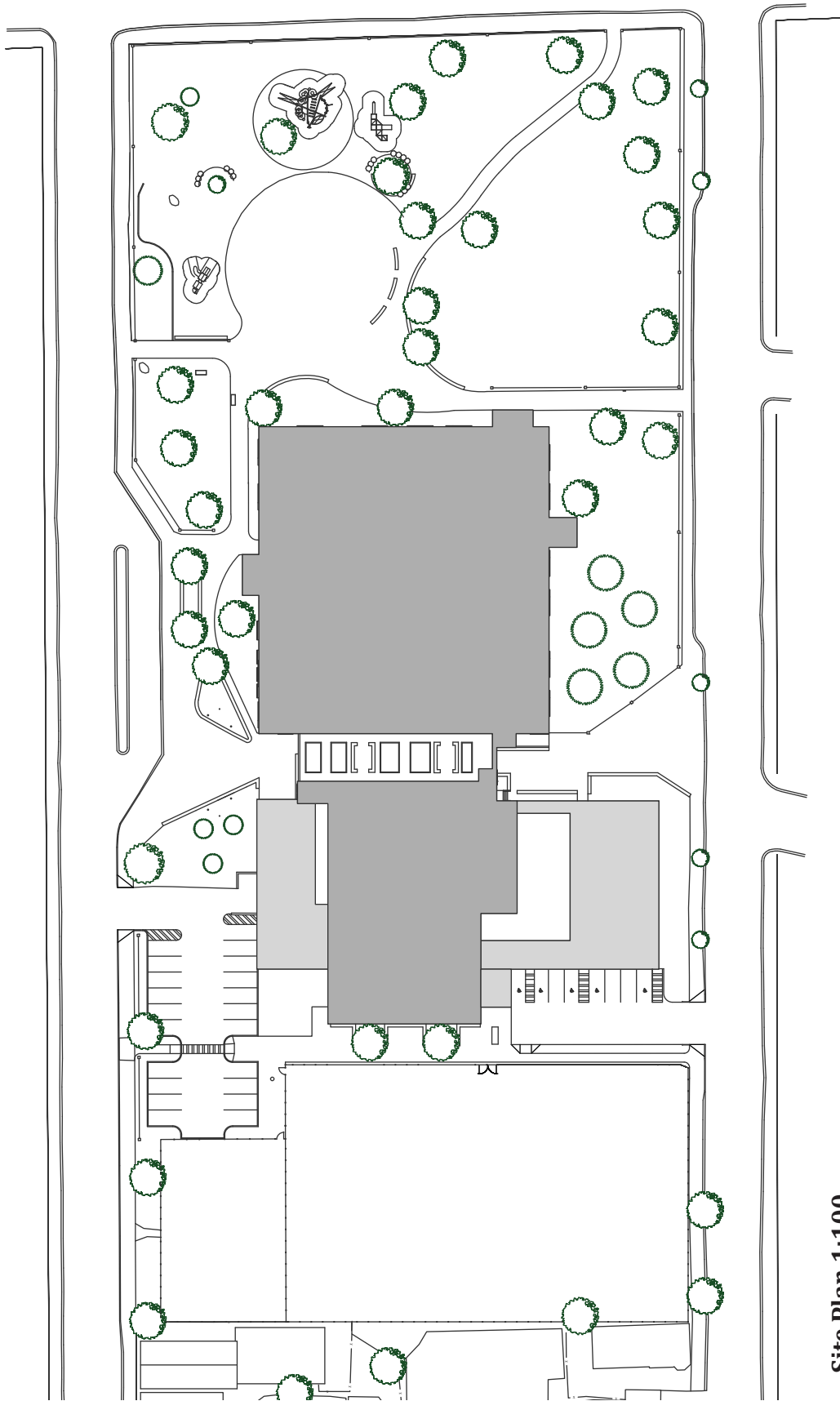

Site Plan 1:100

FIRST FLOOR PLAN

INTERVENTION: ADD INTERIOR WALLS AND RAMPS AND ELEVATORS FOR THE COMMUNITY CENTER AND SCHOOL. SEPERATE THE COMMUNITY CENTER AND SCHOOL ENTRANCES. DESIGNATE THE BRACKETT STREET ENTRANCE AS THE SINGLE ACCESS POINT FOR THE SCHOOL.

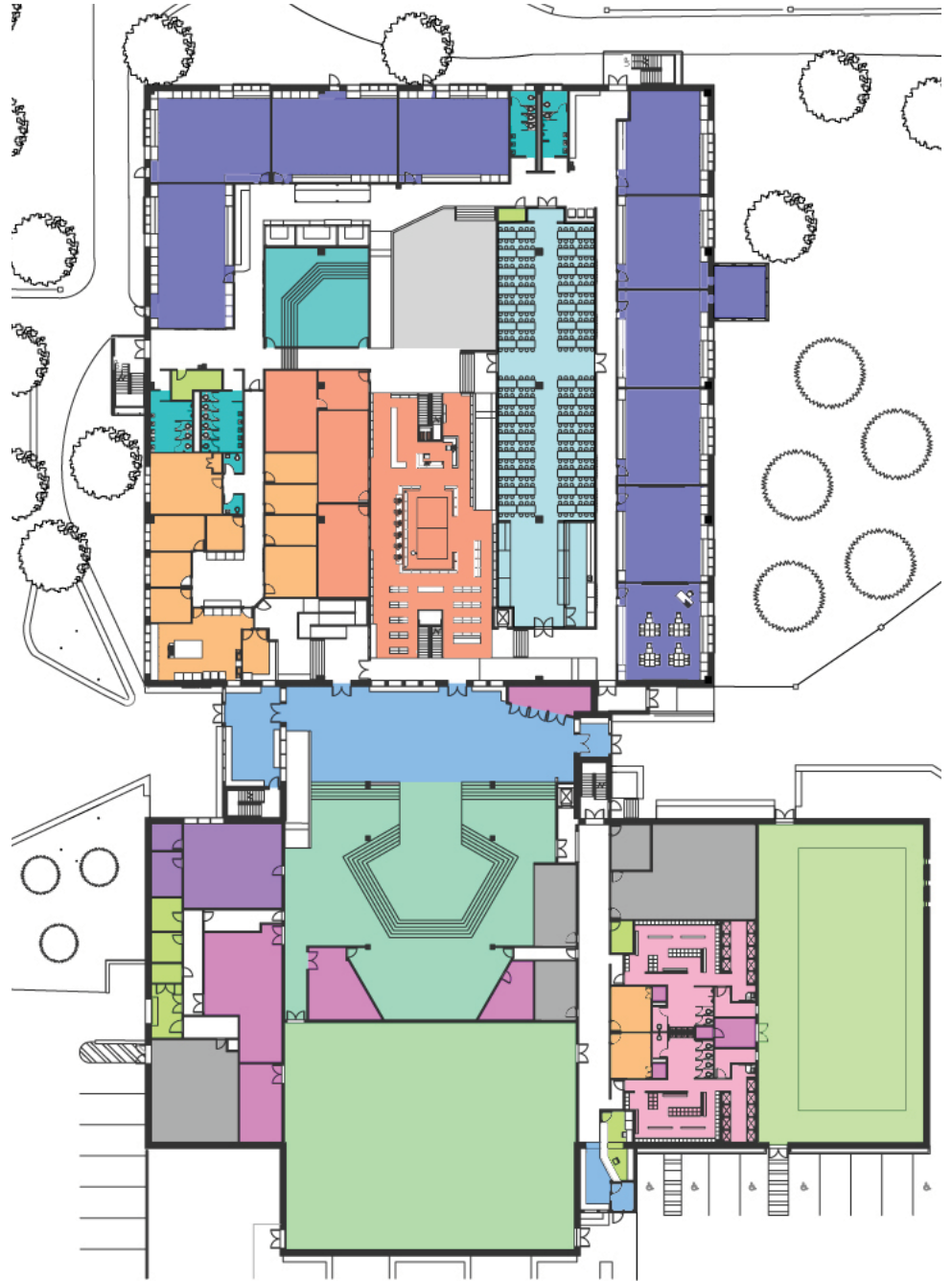
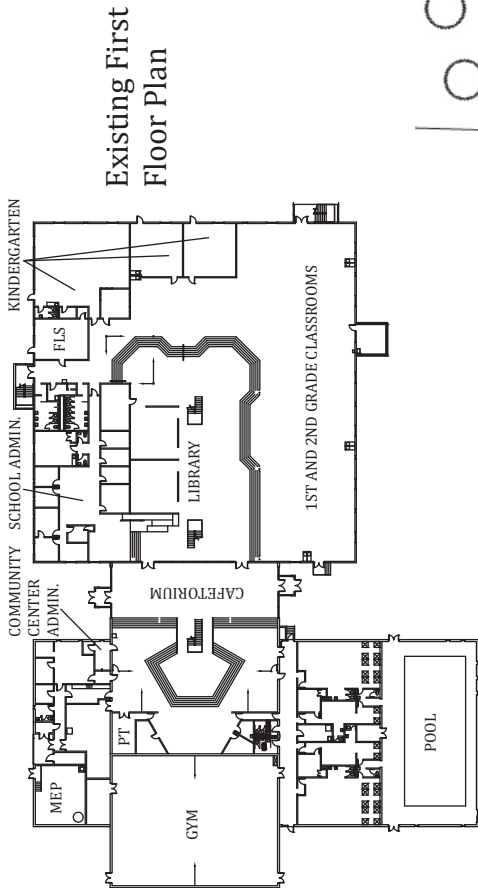

Room Legend

Art Gallery	Auditorium	Boiler Room	Classroom	Community Kitchen	Gym	Janitorial	Lobby	Locker Room	Lunchroom	Meeting Room	Pool	Reception	Staff	Storage	Viewing	WC
-------------	------------	-------------	-----------	-------------------	-----	------------	-------	-------------	-----------	--------------	------	-----------	-------	---------	---------	----

Proposed First Floor Plan 1:60

SECOND FLOOR PLAN

INTERVENTION: ADD INTERIOR WALLS. SWAP THE HEALTH CLINIC AND MUSIC ROOMS TO CLEARLY DELINEATE THE PARTS OF THE BUILDING OCCUPIED BY THE SCHOOL AND THE COMMUNITY.

Existing Second Floor Plan

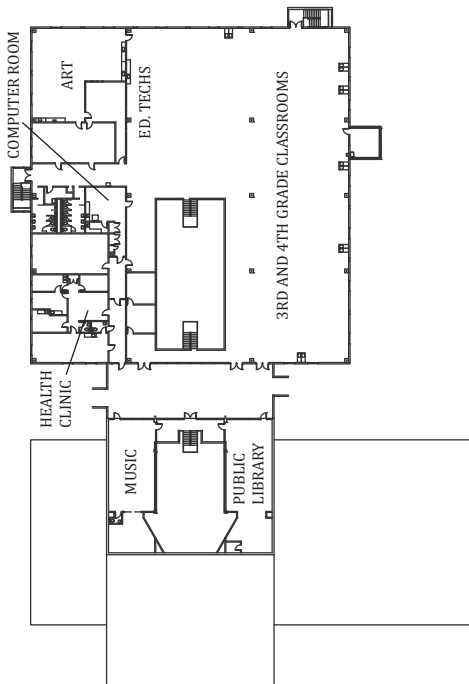

Proposed Second Floor Plan 1:60

APPENDIX XIV

ELEVATIONS



WEST FACADE
Facing Playing Fields



NORTH FACADE
Facing Brackett Street



SOUTH FACADE
Facing Clark Street



EAST FACADE
Facing the Playground

SECTIONS



Section Facing East

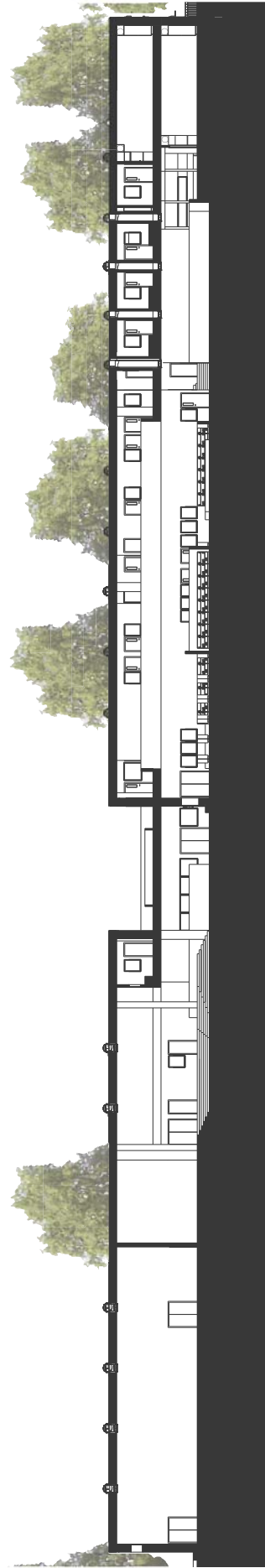

Section Facing North

APPENDIX XVI

CLASSROOM PERSPECTIVES



Classroom Perspective Facing Towards Exterior



Classroom Perspective Facing Towards Building Interior

KINDERGARTEN READING AREA AND LIBRARY PERSPECTIVES



READ TO ME!
READING IS A FUNDAMENTAL SKILL THAT ALL STUDENTS MUST MASTER IN ORDER TO BE SUCCESSFUL IN LIFE.
READING ALLOWS STUDENTS TO EXPLORE NEW TOPICS, ESCAPE FROM THEIR TROUBLES AND FIND ADVENTURE AND WONDER.
TO A READER, THE LIBRARY BECOMES THE CENTER OF ALL KNOWLEDGE. IT IS A PLACE OF WONDER AND EXCITEMENT.

Library



Kindergarten Reading Area

BIBLIOGRAPHY

ACOUSTICAL SOCIETY OF AMERICA (2002). AMERICAN NATIONAL STANDARD ACOUSTICAL PERFORMANCE CRITERIA, DESIGN REQUIREMENTS, AND GUIDELINES FOR SCHOOLS, 5, 7.

ALTER, L. (2008, FEBRUARY). DESIGN AND ARCHITECTURE. SLATE ON “DECIDEDLY DUPABLE” LEED.

AMERICAN PLANNING ASSOCIATION (2008). AMERICAN PLANNERS RECOGNIZE 30 GREAT NEIGHBORHOODS, STREETS, AND PUBLIC PLACES, WWW.PLANNING.ORG/NEWSRELEASES/2008/OCT08.HTM (JUNE 14, 2009).

ARCHITECTURAL RECORD (2007). ROSA PARKS SCHOOL. [HTTP://ARCHRECORD.CONSTRUCTION.COM/PROJECTS/BTS/ARCHIVES/K-12/07_RPSPORTLAND/DEFAULT.ASP](http://ARCHRECORD.CONSTRUCTION.COM/PROJECTS/BTS/ARCHIVES/K-12/07_RPSPORTLAND/DEFAULT.ASP) (SEPTEMBER 4, 2009).

ASHRAE (2007). VENTILATION FOR ACCEPTABLE INDOOR AIR QUALITY: STANDARD 62.1-2007. ATLANTA, GEORGIA, 13.

AUTHOR UNKNOWN (2006). ASSESSING THE ASSESSOR: BREEAM VS. LEED. SUSTAINABILITY MAGAZINE, VOLUME 9, 30-33.

BDP (2009). BRIDGE ACADEMY. [HTTP://WWW.BDP.COM/PROJECTS/BY-NAME/A-E/BRIDGE-ACADEMY/?CATEGORY=18&PARENTPAGEID=24](http://WWW.BDP.COM/PROJECTS/BY-NAME/A-E/BRIDGE-ACADEMY/?CATEGORY=18&PARENTPAGEID=24) (SEPTEMBER 6, 2009).

BRADLEY, CORKY (2009). ENVIRONMENTAL DESIGN AND CONSTRUCTION. PRACTICE MAKES PERFECT. [HTTP://WWW.EDCMAG.COM/CDA/ARTICLES/ARTICLE_ROTATION/BNP_GUID_9-5-2006_A_1000000000000530869](http://WWW.EDCMAG.COM/CDA/ARTICLES/ARTICLE_ROTATION/BNP_GUID_9-5-2006_A_1000000000000530869) (SEPTEMBER 7, 2009).

BRE GLOBAL (2009). THE GREEN GUIDE TO SPECIFICATION: GREEN GUIDE 2008 RATINGS. [HTTP://WWW.THEGREENGUIDE.ORG.UK/GGELEMENT.JSP?BUILDINGTYPE=SCHOOLS&CATEGORY=31&PARENT=0&ELEELEMENTT=10150](http://WWW.THEGREENGUIDE.ORG.UK/GGELEMENT.JSP?BUILDINGTYPE=SCHOOLS&CATEGORY=31&PARENT=0&ELEELEMENTT=10150) (JULY 12, 2009).

BREEAM INTERNATIONAL (2008, NOVEMBER). WHAT IS BREEAM? FREQUENTLY ASKED QUESTIONS.

BRITISH RESEARCH ESTABLISHMENT GLOBAL (2008, AUGUST). BRE ENVIRONMENTAL & SUSTAINABILITY STANDARD: BES 5051: ISSUE 2.0. BREEAM EDUCATION 2008 ASSESSORS MANUAL, 2-396.

BRITISH RESEARCH ESTABLISHMENT (2009). GREEN GUIDE. THE ENVIRONMENTAL PROFILES METHODOLOGY 2008. [HTTP://WWW.THEGREENGUIDE.ORG.UK/PAGE.JSP?ID=55](http://WWW.THEGREENGUIDE.ORG.UK/PAGE.JSP?ID=55) (JULY 12, 2009).

BRITISH RESEARCH ESTABLISHMENT (2009). GREEN BOOK LIVE: ENERGY SAVING RECOMMENDED PRODUCTS: GLAZING. [HTTP://WWW.GREENBOOKLIVE.COM/SEARCH/DISPLAYCOMPANY.JSP?PARTID=10012&SECTIONID=10028&COMPANYID=114019](http://WWW.GREENBOOKLIVE.COM/SEARCH/DISPLAYCOMPANY.JSP?PARTID=10012&SECTIONID=10028&COMPANYID=114019) (JULY 12, 2009).

BUILDING RESEARCH ESTABLISHMENT (2009). SCHOOL DESIGN, GETTING IT DONE RIGHT WITH BRE. [HTTP://WWW.BRE.CO.UK/PAGE.JSP?ID=1037](http://www.bre.co.uk/page.jsp?id=1037) (MAY 25, 2009).

BRITISH RESEARCH ESTABLISHMENT (2006, MARCH). *VENTILATION AND INDOOR AIR QUALITY IN SCHOOLS – GUIDANCE REPORT 20282533*.
[HTTP://WWW.COMMUNITIES.GOV.UK/DOCUMENTS/PLANNINGANDBUILDING/PDF/144155.PDF](http://www.communities.gov.uk/documents/planningandbuilding/pdf/144155.pdf) (JULY 19, 2009).

BSRIA (2009). BREEAM OR LEED STRENGTHS AND WEAKNESSES OF THE TWO MAIN ENVIRONMENTAL ASSESSMENT METHODS. [WWW.BSRIA.CO.UK/NEWS/BREEAM-OR-LEED/](http://www.bsria.co.uk/news/breeam-or-leed/) (AUGUST 1, 2009).

BUTTLER, M. & C. STOY (2009). UNIVERSITÄT STUTTGART – GERMANY. ERES CONFERENCE. COMPARING THE BENEFIT OF INTERNATIONAL ASSESSMENT METHODS.

CITY OF PORTLAND, MAINE (2009). ABOUT PORTLAND. [WWW.CI.PORTLAND.ME.US](http://www.ci.portland.me.us) (JUNE 14, 2009).

COLLABORATIVE FOR HIGH PERFORMANCE SCHOOLS (2009). ABOUT.
[HTTP://WWW.CHPS.NET/DEV/DRUPAL/NODE/133](http://www.chps.net/dev/drupal/node/133) (SEPTEMBER 8, 2009).

COLLABORATIVE FOR HIGH PERFORMANCE SCHOOL (2006). BEST PRACTICES DESIGN MANUAL 2006, VOLUME II, 6, 68.

COLLABORATIVE FOR HIGH PERFORMANCE SCHOOLS (2004). MAINTENANCE AND OPERATIONS MANUAL, VOLUME IV.

COMMISSION FOR ARCHITECTURE AND THE BUILT ENVIRONMENT (DATE UNKNOWN). KINGSMEAD PRIMARY SCHOOL: NORTHWICH, CHESHIRE. [HTTP://WWW.CABE.ORG.UK/CASE-STUDIES/KINGSMEAD-PRIMARY-SCHOOL](http://www.cabe.org.uk/case-studies/kingsmead-primary-school) (SEPTEMBER 6, 2009).

COOPER, A., L. ANDERSON, N. WEDDERKOPP, A. PAGE, K. FROBERG (2005). *AMERICAN JOURNAL OF PREVENTIVE MEDICINE, VOLUME 29, ISSUE 3, OCTOBER 2005, PAGES 179-184*. PHYSICAL ACTIVITY LEVELS OF CHILDREN WHO WALK, CYCLE, OR ARE DRIVEN TO SCHOOL.

CRAWLEY, D. & ILARI AHO (1999). BUILDING ENVIRONMENTAL ASSESSMENT METHODS: APPLICATIONS AND DEVELOPMENT TRENDS. *BUILDING RESEARCH & INFORMATION*; JUL99, VOL. 27 ISSUE 4/5, P300-308.

DEPARTMENT FOR CHILDREN, SCHOOLS AND FAMILIES (2006, JULY). BUILDING BULLETIN 101: VENTILATION OF SCHOOL BUILDINGS: VERSION 1.4, 6-7, 22.

DEPARTMENT FOR EDUCATION AND SKILLS (2003). BUILDING BULLETIN 93: ACOUSTIC DESIGN OF SCHOOLS, 9.

DEPARTMENT FOR CHILDREN SCHOOLS AND FAMILIES (2006). SCHOOLS FOR THE FUTURE, DESIGN OF SUSTAINABLE SCHOOLS: CASE STUDIES.

DEPARTMENT FOR COMMUNITIES AND LOCAL GOVERNMENT (2008). ENERGY PERFORMANCE CERTIFICATES (EPCS) AND NON-DWELLINGS: A GUIDE FOR BUILDING OWNERS, LANDLORDS AND TENANTS.

DEPARTMENT OF COMMUNITIES AND LOCAL GOVERNMENT (2009). ENERGY PERFORMANCE CERTIFICATE (PUBLIC AND COMMERCIAL BUILDINGS)
WWW.COMMUNITIES.GOV.UK/PLANNINGANDBUILDING/THEENVIRONMENT/ENERGYPERFORMANCE/PUBLICCOMMERCIALBUILDINGS/ENERGYPERFORMANCECERTIFICATES/ (AUGUST 1, 2009).

DEPARTMENT OF COMMUNITIES AND LOCAL GOVERNMENT (2009). OTHER BUILDINGS.
WWW.COMMUNITIES.GOV.UK/PLANNINGANDBUILDING/THEENVIRONMENT/ENERGYPERFORMANCE/PUBLICCOMMERCIALBUILDINGS/ (AUGUST 1, 2009).

DEPARTMENT FOR EDUCATION AND EMPLOYMENT (1999). BUILDING BULLETIN 90: LIGHTING DESIGN FOR SCHOOLS, 23.

DEPARTMENT OF EDUCATION SKILLS AND FAMILIES (2007). SCHOOLS FOR THE FUTURE, THE COST OF BREEAM COMPLIANCE IN SCHOOLS, 34, 40.

DOW BUILDING SOLUTIONS (2010). THE ROOFMATE M^{INK} SYSTEM,
[HTTP://BUILDING.DOW.COM/EUROPE/UK/INS/INVERT/BAL/MINK.HTM](http://BUILDING.DOW.COM/EUROPE/UK/INS/INVERT/BAL/MINK.HTM) (MARCH 21, 2010).

ENERGY & RESOURCE SOLUTIONS (2005, JANUARY). NORTHEAST COLLABORATIVE FOR HIGH PERFORMANCE SCHOOLS PROTOCOL VERSION 1.1, 13, 25, 36.

ENVIRONMENT AGENCY (2008). AREAS OF WATER STRESS: FINAL CLASSIFICATION, 5.
[HTTP://PUBLICATIONS.ENVIRONMENT-AGENCY.GOV.UK/PDF/GEHO1207BNOC-E-E.PDF](http://PUBLICATIONS.ENVIRONMENT-AGENCY.GOV.UK/PDF/GEHO1207BNOC-E-E.PDF) (AUGUST 22, 2009).

EVANS, BRIAN (2009). CONSTRUCTING EXCELLENCE. DEMONSTRATION PROJECTS KNOWLEDGEBASE: BRIDGE ACADEMY.
[HTTP://DEMOS.CONSTRUCTINGEXCELLENCE.ORG.UK/KNOWLEDGEBASE/MAIN.PHP?PROJECTID=3440](http://DEMOS.CONSTRUCTINGEXCELLENCE.ORG.UK/KNOWLEDGEBASE/MAIN.PHP?PROJECTID=3440) (SEPTEMBER 6, 2009).

FABER, M. (2009). AECOM. "BREEAM FREQUENTLY ASKED QUESTIONS."
[HTTP://WWW.FABERMAUNSELL.COM/MARKETSANDSERVICES/48/61/INDEX.HTML](http://WWW.FABERMAUNSELL.COM/MARKETSANDSERVICES/48/61/INDEX.HTML) (JULY 10, 2009).

FARISH, TERRY (2003). REGIONAL REVIEW. A RESTAURANT IN PORTLAND LINKS AFRICAN REFUGEES WITH THEIR PAST AND MAINE WITH ITS FUTURE. FEDERAL RESERVE BANK OF BOSTON. OCT. 03, 33.

FOLKERS, RICHARD (1997). US NEWS AND WORLD REPORTS. XANADU 2.0 BILL GATES'S STATELY PLEASURE DOME AND FUTURISTIC HOME, NOVEMBER 23, 1997.

FORBO, 2010. FORBO BULLETIN BOARD,
[HTTP://WWW.FORBOFLOORINGNA.COM/DESKTOPMODULES/IMAGE.ASPX?ID=207&T=DL&OT=QC
KDL&CHC=-739172944&EXT=.PDF](http://www.forboflooringna.com/desktopmodules/image.aspx?id=207&t=DL&OT=QC&KDL&CHC=-739172944&EXT=.PDF) (MARCH 21, 2010).

FORBO, 2010. FORBO ENTRANCE SYSTEMS,
[WWW.FORBOFLOORINGNA.COM/DESKTOPMODULES/IMAGE.ASPX?ID=350&T=DL&OT=QCKDL&C
HC=1877587246&EXT=.PDF](http://www.forboflooringna.com/desktopmodules/image.aspx?id=350&t=DL&OT=QCKDL&CHC=1877587246&EXT=.PDF) (MARCH 21, 2010).

FORBO (2010). M A R M O L E U M[®] D E C I B E L TECHNICAL DATA SHEET,
[HTTP://WWW.FORBOFLOORINGNA.COM/DESKTOPMODULES/IMAGE.ASPX?ID=802&T=DL&OT=D
OCDLCTR&CHC=380618736&EXT=.PDF](http://www.forboflooringna.com/desktopmodules/image.aspx?id=802&t=DL&OT=DOCDLCTR&CHC=380618736&EXT=.PDF) (MARCH 21, 2010).

GIFFORD, H. (2008). A BETTER WAY TO RATE GREEN BUILDINGS. [WWW.HENRYGIFFORD.COM](http://www.henrygifford.com).

GOMEZ, S. (DATE UNKNOWN). *CB RICHARD ELLIS, LTD.* IS THE CLIENT WILLING TO PAY TO OCCUPY A GREENER BUILDING?

GREATER LONDON AUTHORITY (OCTOBER 2006). LONDON'S URBAN HEAT ISLAND: A SUMMARY FOR DECISION MAKERS, 7.

GREEN BUILDING INITIATIVE (2008). GREEN/SUSTAINABLE BUILDING NEWS. GREEN BUILDING INITIATIVE™ RECOGNIZES POURDE SCHOOL DISTRICT'S BETHKE ELEMENTARY SCHOOL FOR SUSTAINABLE DESIGN AND CONSTRUCTION ACHIEVEMENT.
[HTTP://WWW.THEGBI.ORG/NEWS/NEWS/2008/NEWS_200809012_BETHKE_ELEMENTARY.ASP](http://www.thegbi.org/news/news/2008/news_200809012_bethke_elementary.asp)
(SEPTEMBER 4, 2009).

GREEN BUILDING INSTITUTE (2009). CASE STUDY: BETHKE ELEMENTARY SCHOOL, GREEN BUILDING IS ELEMENTARY. [HTTP://WWW.THEGBI.ORG/ASSETS/PDFS/BETHKE-ELEMENTARY-SCHOOL.PDF](http://www.thegbi.org/assets/pdfs/bethke-elementary-school.pdf) (SEPTEMBER 7, 2009).

GREEN BUILDING MAGAZINE (AUGUST 2009). LEED AND BREEAM, HOW DO THEY COMPARE? [HTTP://WWW.UKGBC.CO.UK/LEED.PHP](http://www.ukgbc.co.uk/leed.php) (AUGUST 1, 2009).

GREENBURG, ZACK (2009). AMERICA'S MOST LIVABLE CITIES. FORBES MAGAZINE, [WWW.FORBES.COM/2009/04/01/CITIES-CITY-TEN-LIFESTYLE-REAL-ESTATE-LIVABLE-CITIES.HTML](http://www.forbes.com/2009/04/01/cities-city-ten-lifestyle-real-estate-livable-cities.html)
(JUNE 14, 2009).

HAPPIO, A. AND P. VIITANIEMI (2008). ENVIRONMENTAL ASSESSMENT IMPACT REVIEW. VOLUME 28, ISSUES 7, OCTOBER 2008. A CRITICAL REVIEW OF BUILDING ENVIRONMENTAL ASSESSMENT METHODS, 469-482.

HARPUTLUGIL, G., HENSEN, J. (2006). THE RELATION BETWEEN BUILDING ASSESSMENT SYSTEMS AND BUILDING PERFORMANCE SIMULATION,

[HTTP://WWW.BWK.TUE.NL/BPS/HENSEN/PUBLICATIONS/06_IPRC_ULUKAVAK.PDF](http://www.bwk.tue.nl/bps/hensen/publications/06_IPRC_ULUKAVAK.PDF) (AUGUST 23, 2009).

HOWARD, N. (2005). BUILDING ENVIRONMENTAL ASSESSMENT METHODS: IN PRACTICE. 2005 WORLD SUSTAINABLE BUILDING CONFERENCE, TOKYO.

INFORMED BUILDING (FEBRUARY 2008). LEED NOT WITHOUT CRITICISM.
[HTTP://WWW.INFORMEDBUILDING.COM/INFORMED-CONCEPTS/MAIN6/LEED-NOT-WITHOUT-CRITICISM/](http://www.informedbuilding.com/informed-concepts/main6/leed-not-without-criticism/) (JULY 11, 2009).

INSULATION TECHNOLOGY INC. (2010). EPS INSULATION, [WWW.INSULTECH-EPS.COM/INSULATION.HTML](http://www.insultech-eps.com/insulation.html) (MARCH 21, 2010).

KATS, G. (2006). CAPITAL E REPORT. GREENING AMERICA'S SCHOOLS, COSTS AND BENEFITS, 4, 20.

KINGSMEAD PRIMARY SCHOOL (2009). TRAVEL TARGET.
[HTTP://CLC2.UNISERVITY.COM/GROUPNEWS.ASP?GROUPID=175899](http://clc2.uniservity.com/groupnews.asp?groupid=175899) (SEPTEMBER 6, 2009).

MAINE CHAPTER OF THE UNITED STATES GREEN BUILDING COUNCIL (2009). EAST END SCHOOL, [WWW.MAINEUSGBC.ORG/INDEX.PHP?MODULE=PROJECTS&FUNC=DISPLAY&PID=20](http://www.maineusgbc.org/index.php?module=projects&func=display&pid=20) (JUNE 14, 2009).

LEE, W.L AND J. BURNETT. BUILDING AND ENVIRONMENT. BENCHMARKING ENERGY USE ASSESSMENT OF HK-BEAM, BREEAM, AND LEED. VOLUME 43, ISSUE 11, NOVEMBER 2008, 1882-1891.

NATIONAL CLIMATE DATA CENTER (2002). CLOUDINESS - MEAN NUMBER OF DAYS.
[HTTP://LWF.NCDC.NOAA.GOV/OA/CLIMATE/ONLINE/CCD/CLDY.HTML](http://lwf.ncdc.noaa.gov/oa/climate/online/ccd/cldy.html) (SEPTEMBER 4, 2009).

NATIONAL RESEARCH COUNCIL (2007). GREEN SCHOOLS: ATTRIBUTES FOR HEALTH AND LEARNING, 21, 82, 88-89, 99-100, 103-104, 116-118.

NATIONAL FORUM ON EDUCATION STATISTICS (2003). SCHOOL FACILITIES MAINTENANCE TASK FORCE. PLANNING GUIDE FOR MAINTAINING SCHOOL FACILITIES, 15.

NEW ENGLAND SCHOOL DEVELOPMENT COUNCIL (2009). LONG-RANGE SCHOOL FACILITIES PLANNING, PORTLAND, MAINE. APRIL 2009, 4, 8, 10, 17, 31.

PALMER, JASON (2006). FULL MARKS FOR EFFORT. BUILDING SERVICES JOURNAL JUNE 2006, 43-47.

PARKER, J. (2005, MARCH). ASTHMA REGIONAL COUNCIL OF NEW ENGLAND_ REDUCING ASTHMA TRIGGERS IN SCHOOLS: RECOMMENDATIONS FOR EFFECTIVE POLICIES, REGULATIONS, AND LEGISLATION.

PENOYRE & PRASAD (2009). MINSTER SCHOOL: A COMMON SENSE APPROACH TO SUSTAINABILITY. ECOBUILD CONFERENCE (MARCH 4, 2009).

PORTLAND INTERNATIONAL JETPORT (2009). AIRCRAFT NOISE AND FLIGHT MONITORING SYSTEM: HARBOR VISIBLE FLIGHT TRACKS, WWW.PORTLANDJETPORT.ORG/NOISE.ASP (JUNE 14, 2009).

PORTLAND PUBLIC SCHOOLS (2002). COMPREHENSIVE ELEMENTARY FACILITIES PLAN, 30.

PORTLAND PUBLIC SCHOOLS (2007). ENERGY CONSUMPTION IN PORTLAND SCHOOLS 2007, WWW.PORTLANDSCHOOLS.ORG/FACILITIES/DOCUMENTS/ENERGYCONSUMPTION07.HTM (JUNE 14, 2009).

PORTLAND PUBLIC SCHOOLS (2008). FACILITIES BUILDING CAPACITY, JOINT FINANCIAL COMMITTEE REPORT 2008, 1.

PORTLAND PUBLIC SCHOOLS (2009). MULTILINGUAL AND MULTICULTURAL CENTER. ABOUT US, WWW.PORTLANDSCHOOLS.ORG/SCHOOLS/MULTILINGUAL/ABOUT.HTML (JUNE 14, 2009).

PORTLAND PUBLIC SCHOOLS (2009). PRINCIPAL'S WELCOME TO REICHE SCHOOL, [HTTP://REICHE.PORTLANDSCHOOLS.ORG/](http://REICHE.PORTLANDSCHOOLS.ORG/) (MAY 25, 2009).

POSTEL, S. (2000). ENTERING AN ERA OF WATER SCARCITY: THE CHALLENGES AHEAD. ECOLOGICAL APPLICATIONS: VOL. 10, NO. 4, PP. 941-948.

POURDE SCHOOL DISTRICT (2009). WHERE WE ARE. [HTTP://WWW.PSD.K12.CO.US/PSDINFO/WHOWEARE.ASPX](http://WWW.PSD.K12.CO.US/PSDINFO/WHOWEARE.ASPX) (SEPTEMBER 4, 2009).

RB+B ARCHITECTS (2009). BETHKE ELEMENTARY SCHOOL. [HTTP://RBBARCHITECTS.COM/PORTFOLIO/EDUCATION/BETHKE/INDEX.HTML](http://RBBARCHITECTS.COM/PORTFOLIO/EDUCATION/BETHKE/INDEX.HTML) (SEPTEMBER 4, 2009).

RELOCATE AMERICA (2009). TOP 100 IN 2009, [HTTP://TOP100.RELOCATE-AMERICA.COM](http://TOP100.RELOCATE-AMERICA.COM) (JUNE 14, 2009).

SANTOSA, E. (2007). PENNDESIGN, UNIVERSITY OF PENNSYLVANIA. LEED, A REAL "GREEN" BUILDING GUIDE, 22.

SALVESEN, D., A. SACHS & K. ENGELBRECHT,(2006). INTERGOVERNMENTAL COLLABORATION AND SCHOOL SITING, 9.

SCHAFFER BAUCOM ENGINEERING & CONSULTING (2008). PRESS RELEASE: "BETHKE ELEMENTARY SCHOOL ACHIEVES FIRST LEED® FOR SCHOOLS GOLD" (SEPTEMBER 4, 2009).

SCHEUER, C., W. SCHEUER & G. KEOLEIAN (2002). NATIONAL INSTITUTE OF STANDARDS AND TECHNOLOGY. EVALUATION OF LEED USING LIFE CYCLE ASSESSMENT METHODS, 16.

SCHENDLER, A., & R. UDALL (2005, JUNE 23). LEED IS BROKEN-LET'S FIX IT. GRIST MAGAZINE. [HTTP://WWW.GRIST.ORG/ARTICLE/LEED](http://www.grist.org/article/leed). (JULY 11, 2009).

SCHNEIDER, TODD (2010). NATIONAL CLEARINGHOUSE FOR EDUCATIONAL FACILITIES, SCHOOL SECURITY TECHNOLOGIES, 2-8.

SENECA REAL ESTATE GROUP (2009). ST. THOMAS SCHOOL: MEDINA, WASHINGTON.

SIMON, SCOTT (2006). NATIONAL PUBLIC RADIO, WEEKEND EDITION. SUDANESE REFUGEES FIND NEW HOME IN MAINE. APRIL 29, 2006.

SOLATUBES (2010). SOLATUBE 330 DS-O OPEN CEILING (21 IN/530 MM DAYLIGHTING SYSTEM), [HTTP://WWW.SOLATUBE.COM/RESIDENTIAL/PROFESSIONALS/TECHNICAL-RESOURCES/ASSET_UPLOAD_FILE796_3472.PDF](http://www.solatube.com/residential/professionals/technical-resources/asset_upload_file796_3472.pdf) (MARCH 21, 2010).

SOLATUBE (2010). SOLATUBE PRODUCTS AND LEED 2009, [HTTP://WWW.SOLATUBE.COM/COMMERCIAL/DAYLIGHTING/SOLATUBE-LEED/INDEX.PHP](http://www.solatube.com/commercial/daylighting/solatube-leed/index.php) (MARCH 21, 2010).

U.S. CENSUS BUREAU (2000). STATE AND COUNTY QUICKFACTS. DATA DERIVED FROM POPULATION ESTIMATES, 2000 CENSUS OF POPULATION AND HOUSING, 1990 CENSUS OF POPULATION AND HOUSING, SMALL AREA INCOME AND POVERTY ESTIMATES, COUNTY BUSINESS PATTERNS.

U.S. DEPARTMENT OF EDUCATION (2006-07), NATIONAL CENTER FOR EDUCATION STATISTICS, COMMON CORE OF DATA (CCD), PUBLIC ELEMENTARY/SECONDARY SCHOOL UNIVERSE SURVEY, VERSION 1A.

U.S. DEPARTMENT OF ENERGY (2009). ENERGY STAR BUILDING DESIGN PROFILE: ST. THOMAS SCHOOL. MEDINA, WASHINGTON. [HTTP://WWW.ENERGYSTAR.GOV/INDEX.CFM?C=NEW_BLDG_DESIGN.PROJECT_ST_THOMAS](http://www.energystar.gov/index.cfm?c=new_bldg_design.project_st_thomas) (SEPTEMBER 4, 2009).

U.S. GENERAL ACCOUNTING OFFICE (1995), SCHOOL FACILITIES: CONDITION OF AMERICA'S SCHOOLS, (GAO/HEHS-95-61), 9.

U.S. GREEN BUILDING COUNCIL (2009). LEED 2009 FOR SCHOOLS: NEW CONSTRUCTION AND MAJOR RENOVATIONS. MAY 2009, VI-87. [HTTP://WWW.USGBC.ORG/SHOWFILE.ASPX?DOCUMENTID=5547](http://www.usgbc.org/showfile.aspx?documentid=5547) (JUNE 10, 2009).

U.S. GREEN BUILDING COUNCIL (2008). LEED INITIATIVES IN GOVERNMENTS AND SCHOOLS, [HTTP://WWW.USGBC.ORG/DISPLAYPAGE.ASPX?CMSPAGEID=1852#K-12](http://www.usgbc.org/displaypage.aspx?cmspageid=1852#K-12) (MAY 25, 2009).

U.S. GREEN BUILDING COUNCIL (2009). LEED RATING SYSTEMS, [HTTP://WWW.USGBC.ORG/DISPLAYPAGE.ASPX?CMSPAGEID=222](http://www.usgbc.org/displaypage.aspx?cmspageid=222) (MAY 25, 2009).

U.S. GREEN BUILDING COUNCIL (2008). PROJECT PROFILE, ROSA PARKS SCHOOL.
[HTTP://WWW.USGBC.ORG/SHOWFILE.ASPX?DOCUMENTID=5110](http://www.usgbc.org/showfile.aspx?documentid=5110) (SEPTEMBER 4, 2009).

U.S. DEPARTMENT OF ENERGY (2009). 2008 BUILDINGS ENERGY DATA BOOK, 3-32.

U.S. DEPARTMENT OF ENERGY (2004). SCHOOL OPERATIONS AND MAINTENANCE: BEST PRACTICES FOR CONTROLLING ENERGY COSTS, 51.

U.S. ENVIRONMENTAL PROTECTION AGENCY (2003). AIR POLLUTION AND KIDS: WHAT YOU SHOULD KNOW ABOUT DIESEL EXHAUST AND SCHOOL BUS IDLING, 1.

U.S. ENVIRONMENTAL PROTECTION AGENCY (2005). IEQ TOOLS FOR SCHOOLS: MANAGING ASTHMA IN THE SCHOOL ENVIRONMENT, 3.

VARNEY, GEO. J. (1886). HISTORY OF PORTLAND, MAINE. A GAZETTEER OF THE STATE OF MAINE. B.B. RUSSELL, BOSTON.

WALLJASPER, JAY (2008). DESTINATION SCORECARD: 109 PLACES RATED. NATIONAL GEOGRAPHIC. NOV/DEC. 2008, 120.

WARGO, J. (2002). ENVIRONMENT AND HUMAN HEALTH, INC. CHILDREN'S EXPOSURE TO DIESEL EXHAUST ON SCHOOL BUSES, 5.

WMTV8 (2009). BALDACCI MEETS WITH SUDANESE COMMUNITY LEADERS, MAY 19, 2009.