

2010

A Sustainable Design for the American Commercial Strip Mall

L. Carl Fiocchi, Jr.

University of Massachusetts Amherst

Follow this and additional works at: <https://scholarworks.umass.edu/theses>



Part of the [Architecture Commons](#)

Fiocchi, Jr., L. Carl, "A Sustainable Design for the American Commercial Strip Mall" (2010). *Masters Theses 1911 - February 2014*. 463.
Retrieved from <https://scholarworks.umass.edu/theses/463>

This thesis is brought to you for free and open access by ScholarWorks@UMass Amherst. It has been accepted for inclusion in Masters Theses 1911 - February 2014 by an authorized administrator of ScholarWorks@UMass Amherst. For more information, please contact scholarworks@library.umass.edu.

**A SUSTAINABLE DESIGN FOR THE
AMERICAN COMMERCIAL STRIP MALL**

A Dissertation Presented

by

Louis Carl Fiocchi, Jr.

Submitted to the Graduate School of the
University of Massachusetts Amherst in partial fulfillment
of the requirements for the degree of

Master of Architecture

May 2010

Architecture + Design Program
Department of Art, Architecture and Art History

© Copyright by Louis Carl Fiocchi, Jr. 2010
All Rights Reserve

**A SUSTAINABLE DESIGN FOR THE
AMERICAN COMMERCIAL STRIP MALL**

A Thesis Presented

by

Louis Carl Fiocchi, Jr.

Approved as to style and content by:

Stephen Schreiber, Chair

Kathleen Lugosch, Member

Alexander C. Schreyer, Member

Ray K. Mann
Graduate Program Director
Architecture+Design Program
Department of Art, Architecture,
and Art History

William T. Oedel
Chair, Department of Art, Architecture,
and Art History

DEDICATION

This thesis project is dedicated to Jackie Braconier Fiocchi, wife, best friend, and lover; who as partner in life shares equally in this project.

ACKNOWLEDGMENTS

I would like to thank my professors, Alexander Schreyer, who encouraged and taught me how to keep structure and materials in design; Kathleen Lugosch, who consistently and diligently demanded the next step; Ray Kinoshita Mann, who patiently introduced me to design; and Steven Schreiber, who offered counsel and support from admissions to graduation.

I would also like to acknowledge two special classmates. Jennifer Hayes whose drawing table was across from mine for three years and with whom collaboration and humor were equal parts; and Jesse Selman with whom so many hours were spent in discussion, commiseration, and camaraderie.

ABSTRACT

A SUSTAINABLE DESIGN FOR THE AMERICAN COMMERCIAL STRIP MALL

MAY 2010

LOUIS CARL FIOCCHI, JR., B.A., UNIVERSITY OF PENNSYLVANIA

M.ARCH., UNIVERSITY OF MASSACHUSETTS AMHERST

Directed by: Professor Kathleen Lugosch

The purpose of this project is to present an alternative in form, materials, and energy performance to the existing building type that has been the staple used in construction of American Commercial Strip Malls since the latter part of the nineteenth century.

The project progresses through two phases. The initial phase is the designing of an energy efficient structure that is the basic unit in a system of modularity. This structure permits joining itself together with similar units to form an assortment of assemblies with different possible geometries that are in turn able to respond to various site geometries and retail area programs. The second phase is the development of a site design for a Commercial Strip Mall using an existing site and inserting a combination of the modular design assemblies into that site, maximizing buildable square footage, while attending to all pertinent regulations and codes yet still incorporating desirable design criteria.

The research begins with an initial historical examination of the building type coupled with precedent studies of 1960 American and contemporary European examples.

Research includes identification of all applicable zoning regulations and building codes and within those boundaries determining and incorporating existing available sustainable and energy saving technologies and materials into the design. The economic feasibility of a project of this type is examined through costing software in order to discuss the projects fiscal viability.

In conclusion, the project realizes a design form that aesthetically joins the selected precedents. It is a form that allows construction in a controlled factory setting, mitigating costs, and improving quality. The modularity aspect of the project provides the versatility needed for the design to be employed on different sites; the materials and systems address sustainability and energy performance. Finally, the economic examination supports the idea that building this design or one similar becomes more and more a possibility as peak oil approaches and global warming remedies become mandates.

TABLE OF CONTENTS

	Page
ACKNOWLEDGMENTS	v
ABSTRACT.....	vi
LIST OF FIGURES	xi
CHAPTER	
1. HISTORY	1
Introduction.....	1
Early History of Commercial Shopping Centers	3
Evolution of Contemporary Shopping Centers.....	5
The Commercial Strip Mall	9
2. PRECEDENTS	13
American Design from The Sixties.....	14
Campus Bookstore and Post Office: Stanford University, Calif.	14
Landra Shopping Center, Paolo Alto, Calif.	15
Shopping Center for Chicago Renewal: Hyde Park, Chicago, Ill.....	16
Observations	17
European Designs of Today.....	20
Controlled Signage.....	21
Alternative Transportation.....	22
Public Space.....	22
Deemphasize Parking.....	23
Reflective Ceilings.....	23

Operable Shades.....	24
Transparency.....	24
Integration with Site.....	25
Screening.....	25
Thermal Envelopes	26
Structure as Form.....	26
Material Optimization.....	27
Operable Windows and Shades	27
Daylighting	28
Permeable Paving.....	28
3. THE UNIT MODULE	30
Process	30
Diagramming	30
The American Designs from the Sixties	30
Response to Main Road Axis.....	30
Daylighting	31
Parking	32
Public Space and Landscape Screening	33
European Designs from Today	34
Entrance, Service, Parking, Daylighting, Main Access, Screens	34
Form.....	41
Drawings.....	42
Models and Photo Studies.....	43
Modularity.....	45
Structure.....	50
Components	57

	Extensive Green Roof	58
	Triple Glazing	59
	Permeable Paving.....	60
	Rainwater Harvesting.....	61
	Additional Systems	61
	The Basic Module	63
4.	SITE	68
	Procedure	68
	Context.....	72
	Area Regulations.....	77
	The Site Design.....	78
5.	ECONOMICS	81
6.	DENOUEMENT.....	88
APPENDICES		
A.	CODES AND REGULATIONS	90
B.	COSTING SOFTWARE	105
	BIBLIOGRAGPHY	109

LIST OF FIGURES

Figure	Page
1: Campus Bookstore: Stanford University, Palo Alto, Calif.	14
2: Landera Shopping Center, Paolo Alto, Calif.	15
3: Shopping Center for Chicago Renewal: Hyde Park, Chicago, Ill.	16
4: Campus Bookstore: Stanford University, Palo Alto, Calif.	18
5: Landera Shopping Center: Palo Alto, Calif.	18
6: Shopping Center for Chicago Renewal: Hyde Park, Chicago, Ill.	19
7: MPREIS Wennis, Austria	21
8: MPREIS Zirl, Austria	22
9: MPREIS Zirl, Austria	22
10: MPREIS Wennis, Austria	23
11: MPREIS Wennis, Austria	23
12: MPREIS Achenkirch, Austria.....	24
13: MPREIS Osttirol, Austria.....	24
14: MPREIS Osttirol, Austria.....	25
15: MPREIS Niederndorf, Austria.....	25

16: MPREIS Weissenbach, Austria	26
17: MPREIS Weissenbach, Austria	26
18: MPREIS Zirl, Austria	27
19: MPREIS Sillian, Austria.....	27
20: MPREIS Lagenfeld, Austria	28
21: MPREIS Lagenfeld, Austria	28
22: Axis.....	31
23: Daylighting	32
24: Parking	33
25: Public Space and Landscape Screening.....	34
26: MPREIS Achenkirch	35
27: MPREIS Weissenbach.....	36
28: MPREIS Wenns.....	37
29: MPREIS Sillian.....	38
30: MPREIS Osttirol.....	39
31: MPREIS Niederndorf	40
32: Perspective Views Concept 1-5	42

33: Perspective Views Concept 5	43
34: Concept 7 Perspective.....	43
35: : Concept 8 Perspective 1	44
36: Concept 8 Perspective 2.....	45
37: Concept 9 Roof and Structure Study	45
38: Initial Modularity Concept.....	46
39: Modular Assembly Diagram.....	47
40: Columns & Bearing Walls - Plan	53
41: Shear Walls- - Plan	53
42: Glulams - Plan	54
43: Roof Diaphragm: SIPS Layout – Plan	54
44: Shear Walls	55
45: Columns, Glulams, Bearing Walls	55
46: Steel Frames.....	55
47: SIPS Roofs	56
48: Representational Wall Section with Details	57
49: Extensive Green Roof Detail	58

50: Triple Glazing Detail	59
51: Permeable Paving Detail.....	60
52: Rainwater Harvesting System Detail.....	61
53: Basic Orthogonal Unit	63
54: Level 1 Plan	64
55: Roof Plan	64
56: North Elevation.....	65
57: East Elevation	65
58: West Elevation.....	65
59: South Elevation.....	65
60: Section 1	66
61: Section 2	66
62: Concept 9 Model: View 1.....	67
63: Concept 9 Model: View 2	67
64: Double Diagonal.....	68
65: Double Longitudinal.....	69
66: Diagonal Perspective	70

67: Triple Diagonal Perspective.....	70
68: Triple Longitudinal Perspective.....	71
69: Amherst Road, Rte. 116. Sunderland, Massachusetts	74
70: Satellite Image	75
71: Original Site Plan 1974.....	75
72: Context Map	76
73: Site Key.....	80
74: Site Plan	80
75: Existing Site Square Footages	82
76: Site Designs Square Footages.....	82
77: Green Component Costs	84
78: Daylighting View 1.....	86
79: Daylighting View 2.....	86
80: Sunderland Site in the Present	88
81: View from PVTa toward Strip Mall	89
82: Birdseye View of Strip Mall to Southeast	89
83: Total Construction Costs/SF of Sunderland Strip Mall	106

84: Extensive Green Roof Pricing	107
85: Triple Glazed Window Pricing	108
86: 9" SIPS Pricing	108
87: Night Time	110

CHAPTER 1

HISTORY

Introduction

In the latter part of the nineteenth century, following on the heels of the Industrial Revolution, the invention and inculcation into American society of two radical and innovative forms of mechanical transportation; the trolley and more importantly, the automobile, precipitated a response in both commercial and residential architecture that would repeat itself across the American suburban landscape from that moment to the present. This suburbanization phenomenon departed from the traditional urban and rural formulas of western societies. Its ramifications affected the economic, social, and visual fabric of our cities (large and small) and the vistas of our countryside.

The commercial architecture and the businesses of the central economic districts of the cities attempted to adjust and compensate to the new requirements of space and the speed of both innovations, but it was in vain, as the existing physical limitations of building density, street widths, and limited setback prevailed. At the perimeter of the cities, there was an unregulated frenzy of commercial construction that was erected in the absence of zoning, building codes, architectural input, or planning.

Residential architecture followed, at first at a slightly more sedate and controlled pace attributable to the presence of professionally designed developments, targeted at the upper middle class, exemplified by Oak Park near Chicago, Shaker Heights near Cleveland, or Asbury Park near New York. After World War II, the pace quickened with the affordability and subsequent acquisition of the automobile by Middle America and

accelerated to a hyper-velocity with the return of veterans armed with mortgage money provided by the GI Bill. The Levittowns of America were born.

Our present American canvas consists of a residential growth that has been mirrored in intensity by commercial retail developments necessary to serve those residences and their dwellers. American suburbia stretches from cul-de-sac enclaves just a few miles distant from the centers of the rural towns of Maine in the east or Minnesota in the north, to entangled mazes of streets many miles from the centers of the urban cities of California in the west or Georgia in the south; and all have their accompanying Shopping Malls. A satellite image at night is a canvass whose surface of illuminated tectonic pigments approaches a Jackson Pollack like intensity giving ample phenomenological evidence of America's success at fulfilling Jackson's proclamation of Manifest Destiny.

As an individual who has continually enjoyed the experience of observing built forms of well proportioned geometries, thoughtful and dynamic placements in sites, and skillfully crafted constructions utilizing appropriate and innovative materials the views from the rails, roadways, bike paths, and walking trails of the United States have not been satisfying ones. The purpose of this chapter is to precipitate an understanding of the Commercial Shopping Center and specifically the Commercial Strip Mall for the purpose of designing an alternative that would address its present shortfalls while maintaining or augmenting its economic viability.

To that end, the process will begin with, first, a discussion of the early history of Commercial Shopping Centers up to the second decade of the nineteenth century. Secondly, it will examine the evolution of Commercial Shopping Centers into the three

distinct types that exist today. Finally, it will examine the 5000-100,000 square foot Commercial Strip Mall, which is the focus of interest.

Early History of Commercial Shopping Centers

Between 1880 and 1900, streetcar transportation made urban expansion possible. Here was a rapid and inexpensive means of transportation that allowed access to the perimeters of the cities. Speculators made an assumption that concentrated settlements would spread from the urban center and land values would increase. In light of that, what the speculators erected along the routes were constructions of single row shop fronts, a few with an additional story of lofts or offices, cheaply built with the sole purpose of producing enough revenue to pay the taxes on the parcel and to be easily and promptly demolished in the near future. However, the speculators gamble did not bear the fruit that had been anticipated, because as the automobile supplanted the trolleys sprawl rather than increased density evolved. Consequently, the taxpayer strips were not replaced and were allowed to survive when the desire concentration never materialized.

These buildings were the early progenitors to the contemporary Strip Malls and it is interesting to note that they also spawned their own derogatory term—“Taxpayers”.¹

*By the turn of the century, miles of taxpayers were going up in cities across the country forming vast linear commercial corridors, or what may be called “taxpayer strips”.*²
“Architectural Record” notes in 1918 in Cleveland:

Notes

¹ “Taxpayer” is defined in the American Heritage Dictionary of the English Language, New College ed., as “a building intended to cover the expenses of a piece of land until it can be put to a more profitable use”.

² (Liebs 1985, 12)

Recently the last bars were let down and the trolley cars permitted to run through the exclusive section, familiarly known to the Philistines as "Millionaire's Row." The next logical step is being taken at the very time this is being written and the broad grass plots and shade trees, which added so much of the beauty of this portion of the street, are being cut away and the pavement widened to the line of the down town business section....It will doubtless become a great commercial street.³

As the paving of American byways accelerated so did the proliferation of retail establishments, general stores, hardware stores, farmers supply, etc. and construction responded in a common sense and economical fashion. At first, buildings were set back car lengths from the sidewalk allowing for perpendicular parking, nearby vacant lots were paved, driveways were cut through curbs, and gas pumps were installed. The next change was more radical as the long followed tenet of Main Street commercial site planning, i.e. lining shops along the sidewalk with room only for parking at the curb, was discarded. Buildings moved toward the rear property line, still parallel to the street, but now with a vast paved parking lot separating street from façade.

The disparagement of the Commercial Strips continued. Joining the pejorative "taxpayers" in his 1917 novel, The Dwelling Place of Light, the American author, Winston Churchill, described a strip introducing into the vernacular the phrase "ten footers"

The main artery...is a wide strip of asphalt threaded with car tracks, lined on both sides with incongruous edifices indicative of a rapid, indiscriminating prosperity. There were long stretches of "ten foot" buildings, so called on account of the single story.... These "ten foot" stores were the repositories of pianos, automobiles, hardware and millinery... Flanking the sidewalks, symbolizing and completing the heterogeneous and bewildering effect of the street were long rows of heavy hemlock trunks, unpainted and stripped, with crosstrees bearing webs of wires. Trolley cars rattled along, banging their gongs, trucks

Notes

³ (Frary April 1918, 391-392)

*rumbled across the tracks, automobiles uttered frenzied screeches behind startled pedestrians.*⁴

It is important to be clear that identically to the continually disparaged contemporary Strip Mall these “taxpayers” and “ten footers” were economic stars. Rents were lower than in the downtowns. Large numbers of people lived nearby with substantial volumes of traffic passing by each hour. Customers could arrive by trolley, automobile, bicycle, or by foot. Streets were far less congested than downtown and ample parking was readily available. The melding of profitability and cheap unattractive construction is well noted in Churchill’s phrasing, “undiscriminating prosperity”. These ancestral architectural precedents to our contemporary Strip Mall had evolved into a vigorous and viable species that would continue to thrive and proliferate in its architectural niche. They would become the sharks in the retail ocean.

Evolution of Contemporary Shopping Centers

The previous section, Early History of Commercial Shopping Malls, brought us up to approximately 1920 when there were approximately eight million automobiles on America’s highway. This would expand to twenty three million by the end of the decade. A continued investment, both public and private, into road improvement resulted in 700,000 miles of paved roads outside of the cities by the end of the decade.⁵ That type of growth would continue throughout the century with only World War II causing an interruption as raw materials and factories were diverted toward the war effort. Excepting for that single global conflict the growth would continue unabated; first, aided

Notes

⁴ (Churchill 1917, 15-16)

⁵ (Kyvig 2004, 39)

in the 1930's by Roosevelt's New Deal; then in the 1950's by Eisenhower's twenty five billion dollar support of the 1956 Interstate Highway Act, and finally, by the continued necessity of expanding and maintaining a complex efficient highway network in an America that had become dependent on trucking for the distribution of its products as it distanced itself from rails until we arrive at the present with over four million miles of roads traveled by 62 million cars.⁶

During this same period, there has been a sympathetic evolution in Commercial Shopping Centers, but this evolution has been in a relatively small segment of the entire inventory. The morphing in this segment is best characterized as a creation of a new species with the original specie experiencing a much more superficial evolution. The new specie was the Regional Shopping Center and Mall. This innovation finally transplanted Main Street in entirety to the roadside. A chronological synopsis of that new specie is as follows:

- Country Club Plaza in Kansas City, Missouri opened in 1922. It was America's first commercial regional hub. Although the Plaza was designed and built to accommodate visitors arriving by automobile, it is unlike modern shopping malls with sprawling parking lots; parking was discreetly concealed in multilevel parking garages beneath and behind the shops, or hidden on the rooftops of buildings avoiding the sprawl of modern shopping centers.
- Highland Park Village in Dallas, Texas opened in 1931. It was the first unified commercial development having its stores turned away from the access street.
- Northgate Mall in Seattle, Washington opened in 1950. Shops were on either side of a fifteen hundred foot interior street open only to pedestrians.
- Shoppers World in Framingham, Massachusetts opened in 1952. It was a two tiered structure with an interior grass common and perimeter parking lot for several thousand cars.

Notes

⁶ (Bureau of Transportation Statistics 2008)

- Southdale in Minneapolis, Minnesota opened in 1956 and was America's first roofed over, fully enclosed, air conditioned, completely protected from the weather with no vehicular access mall. Victor Gruen, who over a period of twenty-five years would become the most influential Shopping Center designer in America, was the architect.

This final transformation in the development of regional shopping centers and malls is what transplanted Main Street in entirety to the roadside. Victor Gruen and Larry Smith, Shopping Towns USA: The Planning of Shopping Centers best characterized the reasoning behind that move in 1960:

These spaces must be more than narrow lanes between long rows of stores. They must represent an essentially urban environment. They should create opportunities for manifold activities. They must be busy and colorful, exciting and stimulating, full of variety with places for rest and relaxation and interest. They must not only make walking enjoyable, but must also provide places for rest and relaxation. They should surround the shopper with pleasurable experiences.⁷

The construction of these enclosed climate control malls with more and more amenities of light filled atriums, opulent materials, landscaped interiors, playscapes, and dining courts would continue and accelerate to such a pace that in the 1970's and 80's a new mall opened somewhere every three or four days.⁸ Since that time, the rate of construction of this type of malls has abated and much work is dedicated to the expansion and remodeling of older malls as their period designs have become dated.

Another mutation should also be addressed which is the advent of the "Power Center" which is a larger version of the neighborhood Strip Mall. It draws from a more

Notes

⁷ (Gruen 1960, 159)

⁸ (Underhill 2004, 202)

restricted area than a Regional mall and contains more area than a Strip Mall. One or two large chain stores e.g. Wal-Mart, Target, or Stop & Shop anchor it. These stores are characterized as “Category Killers” for their prices and inventory frequently destroy the local counterpart unable to compete with inventory or pricing.

The reason for delving further into both of the above-evolved types of Commercial Shopping Centers is that the amount of data and reference material applicable to Commercial Shopping Centers is heavily weighted in favor of the regional Shopping Mall with the Power Center a distant second and the Strip Mall a very far distant third. The reason, of course, is economics; for although the number of Strip Malls far exceeds either of the other two types in both number and square footage (see figures below) the construction budgets and research budgets for the first two are understandably vastly larger. Nevertheless, a discriminating read of the available literature on the first two finds many points of information that might be applied to the Strip Mall.

Researching the most current metrics provided by the United States Department of Energy’s (DOE) Energy Information Administration (EIA) Survey the three types of Commercial Shopping Centers may be examined and the following conclusions drawn:

- 4,859,000 Total Buildings (housing not included); 71,658,000,000 square feet
- 657,000 Mercantile (Retail) Buildings; 11,192,000,000 square feet, i.e. 15.6% of all buildings
- 213,000 of Mercantile Buildings are Enclosed or Strip Malls; 6,875,000,000 square feet, i.e. 9.6% of all Buildings or 61.4% of all Mercantile Buildings
Of the 213,000 buildings that are categorized as Enclosed or Strip Malls, we

know that 1100 of them are Enclosed Malls⁹. From the data provided by the DOE we also know that of the 213,000 Enclosed or Strip Malls that 10,000 are greater than

Notes

⁹ (The Columbia Encyclopedia 2009)

100,000 square feet. The 10,000-unit figure safely accommodates the 1100 unit figure and therefore accounts for all of the Enclosed Malls. The typical size of any anchor store in a Power Center is over 100,000 square feet (average Home Depot is 130,000 square feet) so the final resulting number of Strip Malls up to and including 100,000 square feet in size based on EIA information would be 203,000 buildings. The 203,000 Strip Malls of 5000 to 100,000 square feet represents a total of 3,519,000,000 square feet, i.e. 4.9% of all the Total Building square footage or 51% of all the mercantile space in the United States.

It is now clear that the evolutionary path of the Commercial Shopping Center has resulted in three distinct species of which our interest turns specifically to the 5000 to 100,000 square foot Commercial Strip Mall. These buildings are worthy of a focus of study as they have proliferated across the country (203,000 units). They are successful economic entities accounting for 51% of all retail space. They have been cheaply constructed and poorly designed in the tradition of the early “taxpayers”. They are an overall aging part of our infrastructure and their appearances and dates of construction indicate it is time for either reconstruction or razing and new construction now or in the near future.

The Commercial Strip Mall

Strip malls usually range in size from 5,000 square feet to 100,000 square feet. The smaller variety is more common and often located at the intersection of major streets in residential areas and caters to a small residential district. This type of strip mall is found in nearly every city or town in the United States. It is service-oriented and may contain a convenience store, video rental store, dry cleaner or laundromat, package store,

small restaurant, or similar stores. Gas stations, banks, or national fast food chains may have their own freestanding buildings within the site. The architecture of Strip Malls varies. Older strip malls tend to have plain architecture with the stores arranged in a straight row. Newer Strip Malls are often built with architecture that is more elaborate in an attempt to blend in with the neighborhood and to attract the upscale consumer.

First, appraising the siting of the structures, the building location and position within the site is based on the following parameters:

- Maximize the amount of rentable retail square footage.
- Maximize the ease of access from the principle road artery into the site.
- Maximize the number of parking spaces with the most direct access into the building.
- Simplify site maintenance requirements e.g. landscape care, snow removal, and waste removal.

If those four parameters are fulfilled then the building has been successfully sited and planning can move on to the next phase. Never except in the case of coincidence is consideration given to correct solar positioning, prevailing wind patterns, sheltering topography, screening of trash collection areas and dumpsters from neighbors and public realm, or availability of desirable views.

Secondly, examining the buildings themselves recognizes these repeated attributes of form and geometry:

- Flat roofed and one storied carrying on the tradition of the “Ten Footers” Sometimes a mansard roof (frequently only on the façade side) to provide a place for signage and a nod to the traditional architecture.
- Commonly footprints of rectangles consisting of three unadorned sheer walls punctuated only by individual steel doors located at employee entrances. Fenestration and retail entrances dispersed evenly on the remaining side located parallel to the access road.
- A minimal overhang located above the storefronts. Its depth determined by sidewalk widths rather than solar shading.
- Signs popping up over the parapet or applied to the mansard if available

Thirdly, these repeated attributes of materials:

- Roofs, as mentioned above are predominantly flat which removes the choice of materials from the public realm. The mansards, if present, are shingled with asphalt more typically than wood or more recently standing seam metal (available in five color choices).
- Masonry walls of painted or unpainted block, or brick if initial budget allowed as this product reduced future maintenance costs.
- The windows and entrance doors are metal framed (originally milled aluminum, more recently with an anodized bronzetone finish) with plate glass.
- Sidewalks are concrete; parking lots are asphalt.
- There are efforts made in some cases to upscale, conform to the neighborhood, or modernize using various systems, e.g. horizontal siding (clap boards or shingles) and paint, vertical siding and stain (the organic and natural look), or EIFS (Drivite) a system that produces a colored stucco like finish (several textures available), slightly improving the buildings thermal envelope, yet has the disadvantage that when dented reveals the underlying styrofoam that supports the finished one quarter inch thick veneer.

Exacerbating the above is the absence of dumpster screening, the additions of unshielded commercial freezer boxes, zoning permitted storage sheds (inevitably trimmed in white with cross-bucked entrance door, mismatched signage (previous sign anchor points frequently visible), and the occasional industrial garbage cans.

Compounding this conglomeration is the fact that not only has the maintenance of all surfaces been put on deferred (except the roof, as we can see evidence of recent work where the roofing tar has dripped over the parapet flashing) or thought of as not necessary in the case of vinyl “needs no maintenance” siding. The results are a structure that is covered with 5, 10, 20, or 30 years of road dust, automobile pollution, and splatters of indeterminate liquids.

The surrounding environment keeps pace with the building itself. What there is of greenscape or landscape is usually a token strip near street edge or between asphalt and concrete sidewalk at the building front consisting of gumdrops of ragged ewes

swimming in a sea of faded bark mulch littered with cigarette butts. Litter intensifies as the secondary edge of the site, i.e. unbuildable adjacent lots or the no man's land between utilized traffic lane and site boundaries, are approached; we find overgrown weeds and scrub bushes serving as terrific collectors of styrofoam cups and fast food wrappers. Lighting is of the most utilitarian serving only to illuminate signage or provide a sense of security for when the parking lot is navigated in the dark.

Overall, it is an exceedingly dismal portrait of America's dominant commercial structures. To this amalgamation, we would now introduce one more parameter and that is energy, specifically a dependence on fossil fuel base energy sources. It practices not only dependence, but also a profligate overuse of those resources. It is a fair claim to make that the Commercial Strip Mall has never made a single concession to energy management. It has not addressed envelope efficiency in the form of thermal conductivity or air infiltration; window technologies with increased U-values or SHGC; selection of materials based on point of origins or petroleum sourcing, passive technologies e.g. solar, wind, or geothermal; passive ventilation systems, daylighting strategies, water use conservation, or permeable paving, etc. etc.

Finally, in addition to all the shortcomings of the Commercial Strip Mall enumerated above we must add one more and that is that the building form does not add one single element of appreciated and valued public space to the community. This is an ignominious crown to a battered built form that is enormously successful (203,000 units nationwide) because of its one overriding feature, which is, it moves product to the American consumer with extraordinary efficiency and minimal expense.

CHAPTER 2

PRECEDENTS

*A store—the most commercial of commercial buildings—must be conceived, arranged, and designed to sell goods; and if it fails in this requirement it has no reason to exist. The fact that a store is built to make money in no wise precludes the possibility that it can also be well designed architecturally. Contrariwise, one can hardly expect a perfect gem of store design to entice visitors into buying merchandise based on aesthetic appeal alone.*¹⁰

After a single page preface, James S. Hornbeck, offers this very succinct paragraph defining a store. The paragraph encompasses the two qualities in commercial retail that should be married into each project, good design and the structures ability to produce retail dollars.

With those two qualities in mind, two periods for precedents were examined. The first was the a period beginning in the 1960's when Strip Mall construction responding to the post World War II housing boom was itself in high production. This made available a large number of precedents from which to choose and given the long life spans of this type of construction, an excellent opportunity to see what has survived to the present. The second period is that of contemporary 2009.

While both periods did produced precedents that will be enormously helpful, it must be noted that given the sheer quantity of the building form there are surprisingly few that meet Hornbeck's dual criteria providing model examples for this project.

Notes

¹⁰ (Hornbeck 1962, 1)

American Design from The Sixties

Campus Bookstore and Post Office: Stanford University, Calif.

This project was the second phase of what would be a nine building student activity center. The initial two buildings have graceful, flattened arched arcades of buff colored concrete which respectfully acknowledge the strong statement of the earlier campus architecture of rusticated buff stone, red tile roofs and many arches which are the campus hallmark; but they do this in their own completely contemporary idiom.

The vaulted forms were precast and lifted into place on top of the cast-in place columns. Concrete bents for roof and wall framing were also precast. Loads transmitted to columns through connections at column tops. The system frees glass panels on both sides of the Book Store for light and transparency.¹¹ In addition, the apex of the gabled roof is skylighted on both sides accentuating the lofty feeling with sky and daylighting.

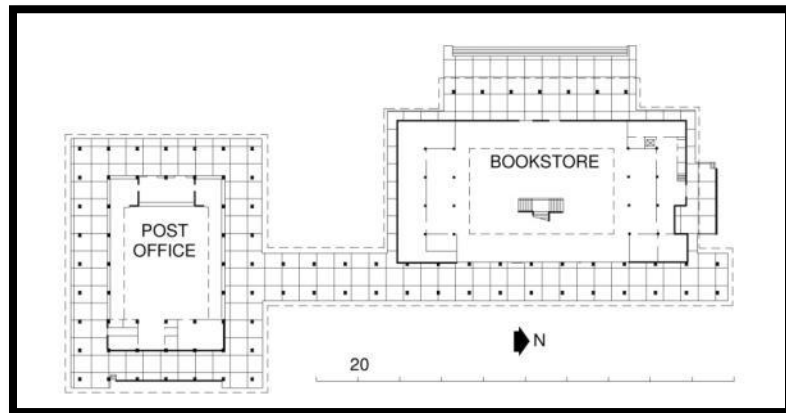

Figure 1: Campus Bookstore: Stanford University, Palo Alto, Calif.
Plan 1960: Drawing by Author

Notes

¹¹ (Hornbeck 1962, 38,39)

Landera Shopping Center, Paolo Alto, Calif.

This shopping center echoes the character of its environment, upscale residential, which strives to maintain its rural quality. The center's wide spreading wood-shingled roofs, informal groupings of three low buildings, and rustic character expressed by exposed wood construction with either glass or redwood board and batten infilling contribute to the effect. The deep shade of the low hung, sheltering arcades add inviting coolness on hot days as does the fountain. All signs were under the control of the architect.

The plan is based on the idea that the shopper is a pedestrian. The three buildings that form the center are grouped in L shape, linked together by covered walks; and are oriented to face upon an open landscaped courtyard that can be reached directly from the parking area.¹²

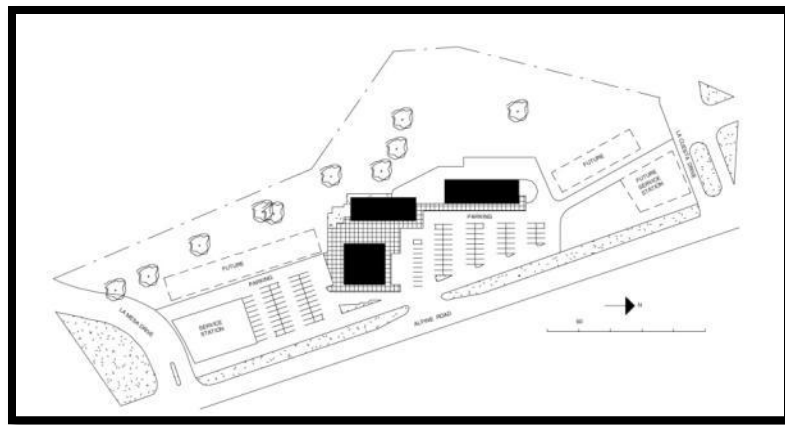

Figure 2: Landera Shopping Center, Paolo Alto, Calif.
Plan 1960: Drawing by Author

Notes

¹² (Hornbeck 1962, 143)

Shopping Center for Chicago Renewal: Hyde Park, Chicago, Ill.

This center was built as an element in the 900-acre Hyde Park-Kenwood urban renewal program in Chicago. It is physically separated from the residential area and integrated into the planning of surrounding neighborhoods. The basic design consists of 12-foot columns, freestanding, to make non-modular partitioning by tenants possible. The window heads were scaled down to door height to calm the view, so often dominated by fluorescent fixtures and the innards of the stores. The band between the 7' and 9' points, where the brick begins is for signs. Freestanding, thin shell concrete canopies shade the sidewalks and serve to conceal cooling towers for the boutiques. The parapet was originally 3 feet taller, which created concealment for the rooftop mechanicals, but was reduced in height because of control building costs.¹³

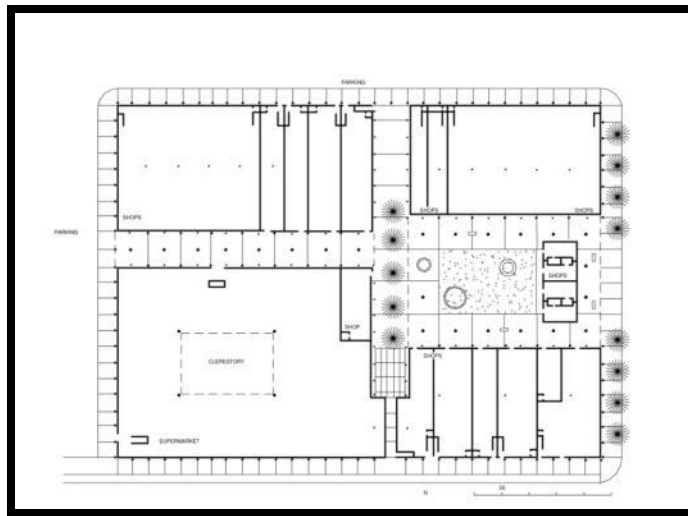

Figure 3: Shopping Center for Chicago Renewal: Hyde Park, Chicago, Ill.
Plan 1960: Drawing by Author

Notes

¹³ (Hornbeck 1962, 154,155)

Observations

The first two precedents are designed by John Carl Warnecke, the third by I. M. Pei. Pei is not in need of introduction, but Warnecke is in need of some biography. Warnecke was the designer for the JFK Memorial at Arlington, the New Executive Office Building in Washington, D.C. and several other principle buildings in Washington and New York.

It is an acknowledgement of their competencies that they applied their powers of design to these small examples of a vernacular building form. They have incorporated traditional elements of the language of architecture into their buildings texture, pattern, rhythm, and scale to arrive at buildings that pay attention to materiality, transparency, circulation, solar position, daylighting, response to adjacencies, and the public realm.

Attentions to these elements are the reason they have survived nearly fifty years in basically intact forms. Economic viability was present for sure; but all three locations are areas where raze and rebuild tactics are employed if the opportunity for more profits present themselves. The Stanford project has had its originally planned expansions and the Landera Shopping Center has survived unscathed. Pei's project in Chicago has succumbed the most, with the destruction of one section to allow for more parking along with the covering of the main skylight. The pressures of the automobile and high square footage lease rates probably the causes. However, the developers have maintained Pei's Public Space and the space continues to separate the pedestrian from the automobile, elevate the stores, and welcome the public.

Additionally, a comparison of images from past and present supports the success of all three:



Figure 4: Campus Bookstore: Stanford University, Palo Alto, Calif.
 Image: Courtesy of Google Earth™ Plan 1960: Drawing by Author



Figure 5: Landera Shopping Center: Palo Alto, Calif.
 Image: Courtesy of Google Earth™ Plan 1960: Drawing by Author

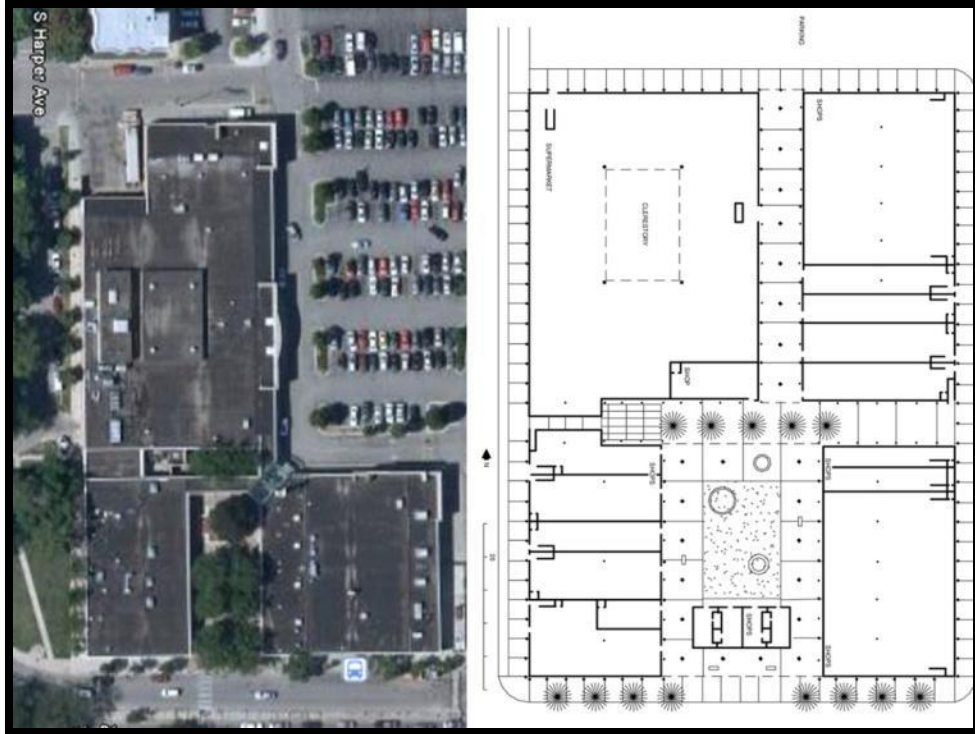

Figure 6: Shopping Center for Chicago Renewal: Hyde Park, Chicago, Ill.
 Image: Courtesy of Google Earth™ Plan 1960: Drawing by Author

An essay by William T. Snaith, “How Retailing Principles Affect Design”¹⁴, is pertinent to this period of design. The article, slightly antique (47 years old in 2009), offers some discerning insights that might or might not apply today:

Contrary to every traditional architectural dictum that building design is conditioned by the land, no store site must be able to dictate a bad positioning of the building in terms of retailing.

The store must decide whether it is better to show extensive parking or to show the store itself. The distribution of required area into lots or into a front or rear plaza depends upon the impression the store wants to convey. Careful of empty lots.

Fronts are regarded as facing on streets or traffic. Consider a store as having two fronts; one that a customer sees in passing or arriving, the other that he sees when he actually enters.

Notes

¹⁴ (Hornbeck 1962, 2 -10)

Signs located below the canopy at the proper eye-level and are controlled by the design of the canopy and the sign areas themselves.

It is evident that while there is a canny understanding of design as it relates to retail there is a shortsightedness of some precepts that must reappear as energy conservation has moved to the forefront.

European Designs of Today

In Europe, things were and are ahead of the American curve. Driven by the European Union's acceptance of the Montreal Protocol and the agreement of all the Union's 27 countries to the Energy Performance of Building Directive -- a century of retail design is beginning to be reversed.

The Tyrolean chain MPREIS values quality architecture, commissioning new stores without insisting on any specific corporate design, and is always open for new architectural concepts.

Mpreis speaks in eloquent fashion about their philosophies. From the MPREIS website¹⁵:

A brand is usually made recognizable through uniformity. MPREIS chose a radically different approach: our trademark is a varied architectural design vocabulary – each store is especially created for its location, yet it is always recognizable as an MPREIS store. So far, we have cooperated with over 30 different architects, who were challenged by these requirements to constantly develop new ideas.

One trademark is a varied architectural design vocabulary that creates interiors with a pleasant ambience. Places with demanding architecture create an identity for the region and its people. High value is placed on the responsibility for the characteristics of the regional landscape and its cultural traditions.

Notes

¹⁵ (MPREIS 2009)

Definition of sustainability according to the “Local Agenda 21 Tyrol”: the concept of sustainability is based on the insight that economic performance, social responsibility and the protection of the natural environment are inseparable. Sustainability means fulfilling the needs of present generations without creating negative effects on the opportunities of future generations. Only a successful business is able to act in a future-oriented way and to take responsibility for social and cultural issues as well as for the environment. The investigation of renewable energy sources and the promotion of technological innovation are important elements of sustainable development. The sensitive use of non-renewable resources completes this responsible approach.

The investigation of renewable energy sources and the promotion of technological innovation are important elements of sustainable development. The sensitive use of non-renewable resources completes this responsible approach. Therefore, it is important for MPREIS to reduce its energy consumption through efficient energy management and the use of new technologies. Motion detectors in rarely used rooms or energy efficient ventilation systems in refrigerator units are examples of concrete measures that help save energy. Geothermal heat pumps are used for heating and in all MPREIS markets, waste heat from cooling systems is used as a source of energy.

The implementation of their philosophies is evident in the following designs:

Controlled Signage



Figure 7: MPREIS Wengs, Austria
Image by Author

Alternative Transportation



Figure 8: MPREIS Zirl, Austria
Image by Author

Public Space



Figure 9: MPREIS Zirl, Austria
Image by Author

Deemphasize Parking



Figure 10: MPREIS Wenneß, Austria
Image by Author

Reflective Ceilings

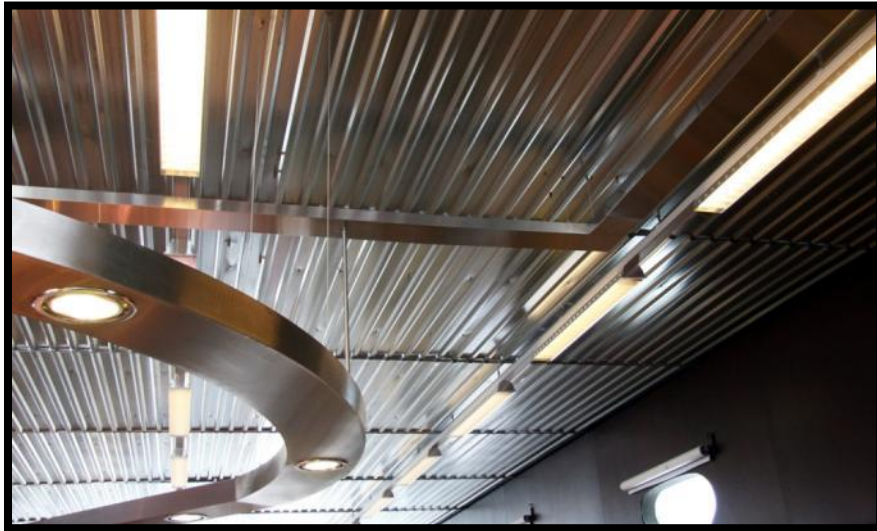

Figure 11: MPREIS Wenneß, Austria
Image by Author

Operable Shades



Figure 12: MPREIS Achenkirch, Austria
Image by Author

Transparency



Figure 13: MPREIS Osttirol, Austria
Image by Author

Integration with Site



Figure 14: MPREIS Osttirol, Austria
Image by Author

Screening

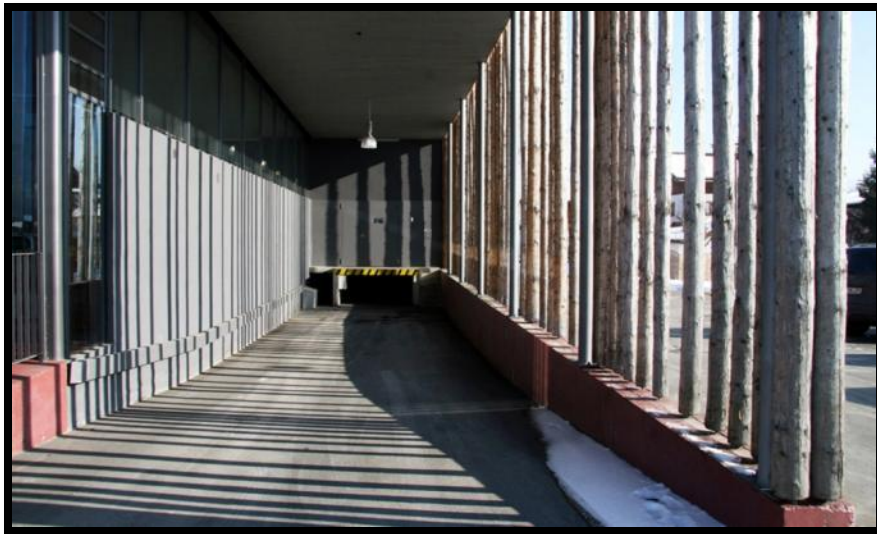

Figure 15: MPREIS Niederndorf, Austria
Image by Author

Thermal Envelopes



Figure 16: MPREIS Weissenbach, Austria
Image by Author

Structure as Form



Figure 17: MPREIS Weissenbach, Austria
Image by Author

Material Optimization



Figure 18: MPREIS Zirl, Austria
Image by Author

Operable Windows and Shades



Figure 19: MPREIS Sillian, Austria
Image by Author

Daylighting



Figure 20: MPREIS Lagenfeld, Austria
Image by Author

Permeable Paving



Figure 21: MPREIS Lagenfeld, Austria
Image by Author

In addition to the illustrations above the following are elements, materials, systems or techniques that are incorporated into the buildings:

- Ceiling height always about 16' - 20' then pitched to 12' at minimum.
- General lighting might be ceiling mounted, but all lighting fixtures along with any mechanicals that are ceiling sourced are brought down to about 10' level to define space below.
- All lighting is LED or CFL, no exceptions.
- Air conditioning is rare and if it appears, it is restricted to café areas.
- Entrance doors are rapid moving sliders with sensors that react only when an individual is very close to the door.
- Small supplemental heating units are located at interior of each entrance.
- Layout of stores is consistent from one to another: café, main selling area, service and staging.
- Fixtures and appointments are also consistent from store to store excepting finishes (laminates, furniture style, wallcoverings, etc.) which are individualized in cafes.
- Heating is accomplished with either area space heaters or hydraulic system in slabs. The area space heaters will also circulate unconditioned air.
- All toilets are double flush, no exceptions.
- Windows are all double glazed plate glass.

MPREIS is at present an anomaly in the retail built environment, but it lends credence to the idea that there can exist well designed, sustainable, and environmentally responsible commercial retail establishments. MPREIS' revenues from their 150 markets and 133 cafes exceed one half billion dollars. The population of Tyrolea is 700,000, which means America could support 70,000 similar facilities in the United States. American retail chains should either observe and learn or beware!

CHAPTER 3
THE UNIT MODULE

Process

Diagramming

The first step in the design process was diagramming both sets of precedents in order to document the attributes that the precedents have in common. This would highlight and underscore the traits that they all shared as successful examples of their building type and these commonalities would then become design parameters and dictates.

The American Designs from the Sixties

Note: All photographs are oriented with North toward top of page.

Response to Main Road Axis

In all three instances, optimum solar orientation was ignored and the directive of the principle road way was selected. While the Campus Bookstore is not directly on an automobile trafficked street, its axis selection is consistent, and in that, it is parallel to the pedestrian thoroughfare to its west. This is instance of the parameters of retail marketing superseding traditional practice. The daylighting diagram (see Figure 23) demonstrates effort to mitigate this positioning and, of course, the two precedents in California were also responding to defense against solar gain.

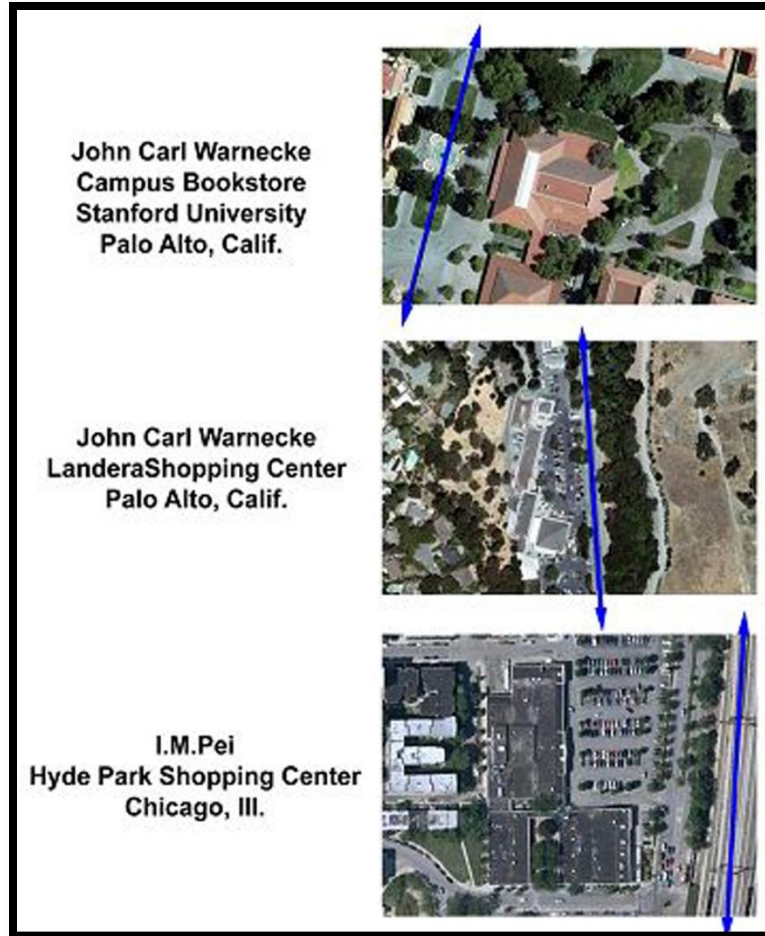

Figure 22: Axis
Images: Courtesy of Google Earth™

Daylighting

The three precedents offer assorted strategies, but all to the same end of introducing natural light into the interiors. The Campus Bookstore and Post Office achieves the result through a large skylight (approximately 40' x 70') in the Bookstore and four sides of clerestories in the Post Office. The Landera Shopping Center uses a slender footprint of forty feet with daylighting on much of the perimeter. Pei in the Hyde Park facility utilizes a skylight (approximately 46' x 70') and although an eighty foot deep footprint daylights on many of the sides.

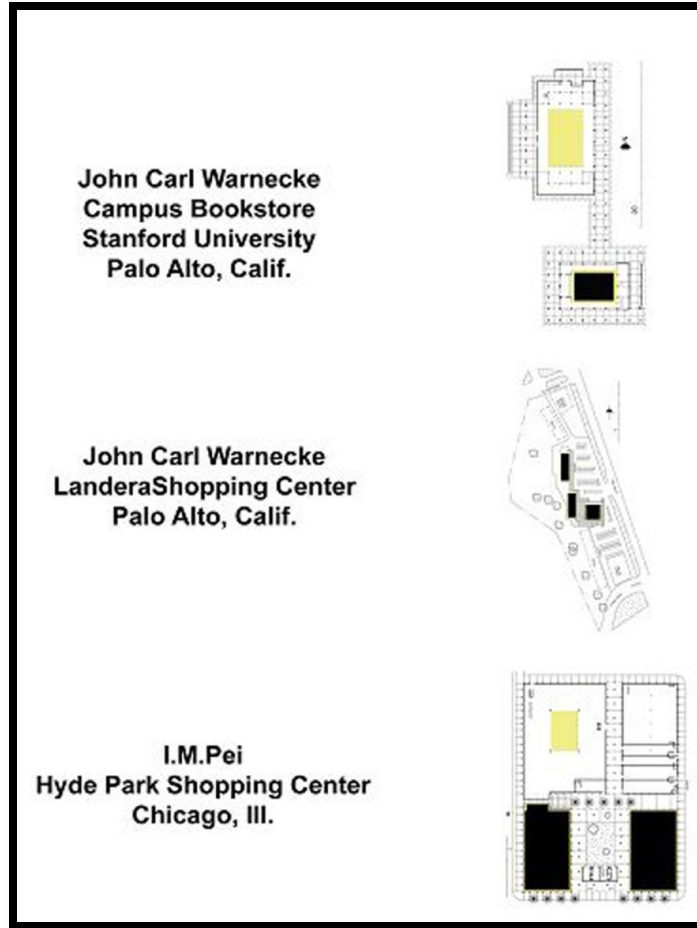

Figure 23: Daylighting
Drawings by Author

Parking

As a campus site, the project at Stanford is predominantly pedestrian and therefore was not in need of adjacent parking only service access. At the Landera site, parking is adjacent to the north building; but is at some distance from the two southern buildings. Similarly, at Hyde Park the parking is adjacent to the north building; but is at some distance from the two southern buildings as in the Landera project.

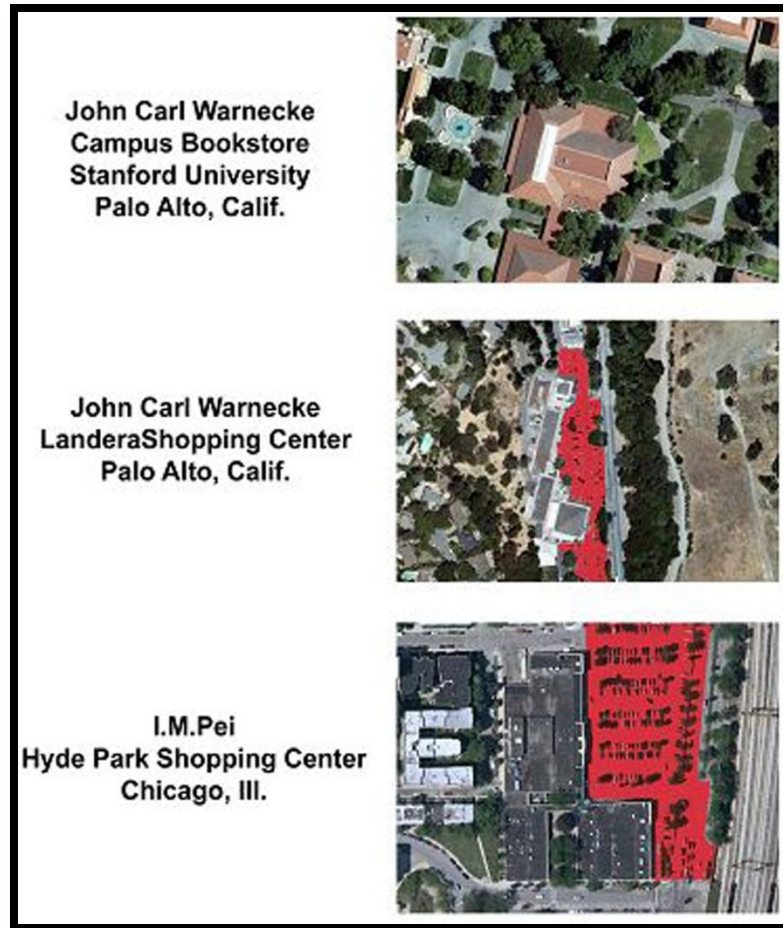

Figure 24: Parking
Images: Courtesy Google Earth™

Public Space and Landscape Screening

In the campus, setting Warnecke integrates public space with landscaping while at Landera, the road and parking are screened by landscaping and Public Space is integrated into the midst of the complex. At Hyde Park, Pei is again recapitulating Warnecke (or vice versa).

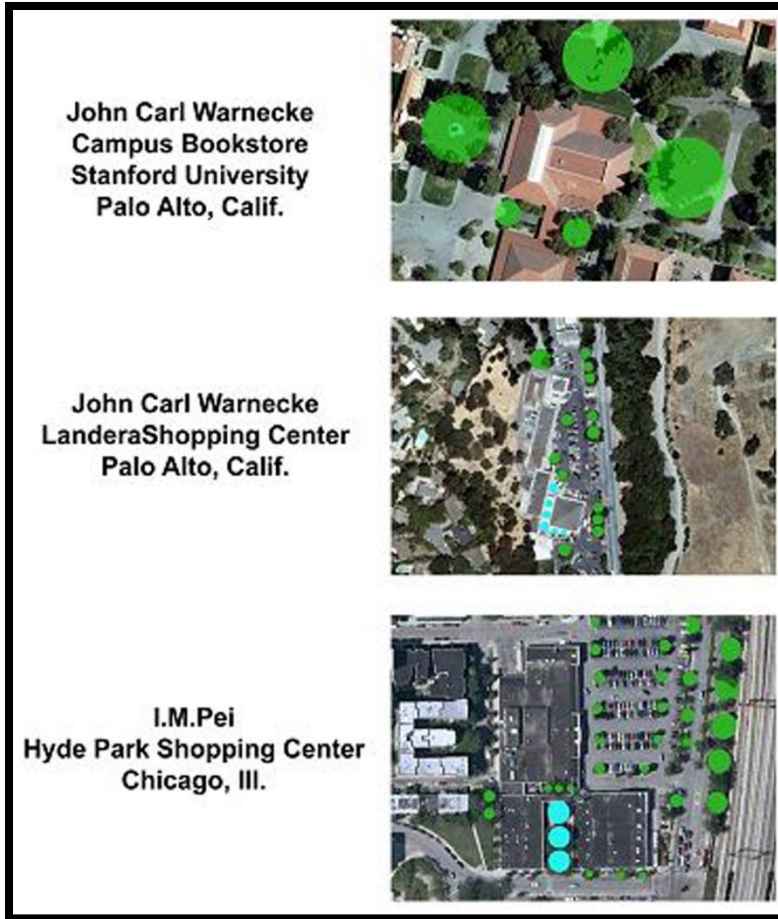

Figure 25: Public Space and Landscape Screening
 Key: Green = Landscape Screening Blue = Public Space
 Images: Courtesy of Google Earth™

European Designs from Today

These structures, in similar fashion to the sixties precedents, address axis, daylighting, parking, entrance, service, public space, and landscape screening.

Entrance, Service, Parking, Daylighting, Main Access, Screens

Note: All Google Earth images are oriented with North toward top of page.



Figure 26: MPREIS Achenkirch
Images by Author and Courtesy of Google Earth™

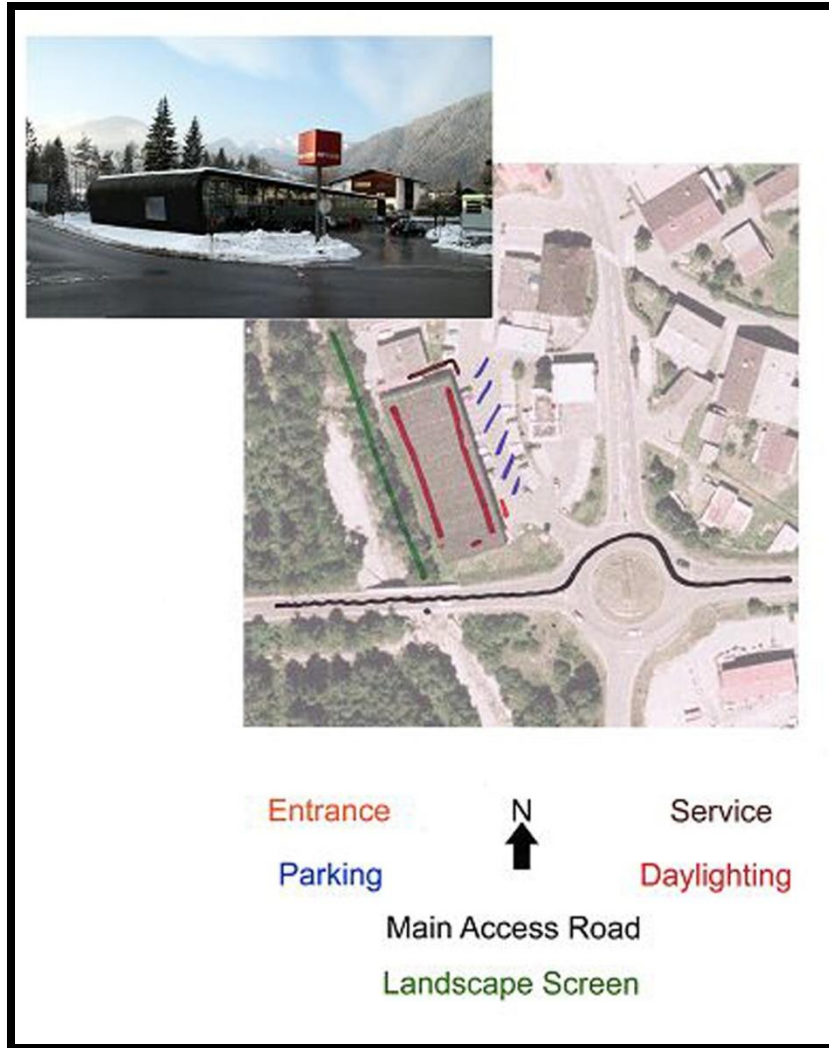

Figure 27: MPREIS Weissenbach
Images by Author and Courtesy of Google Earth™

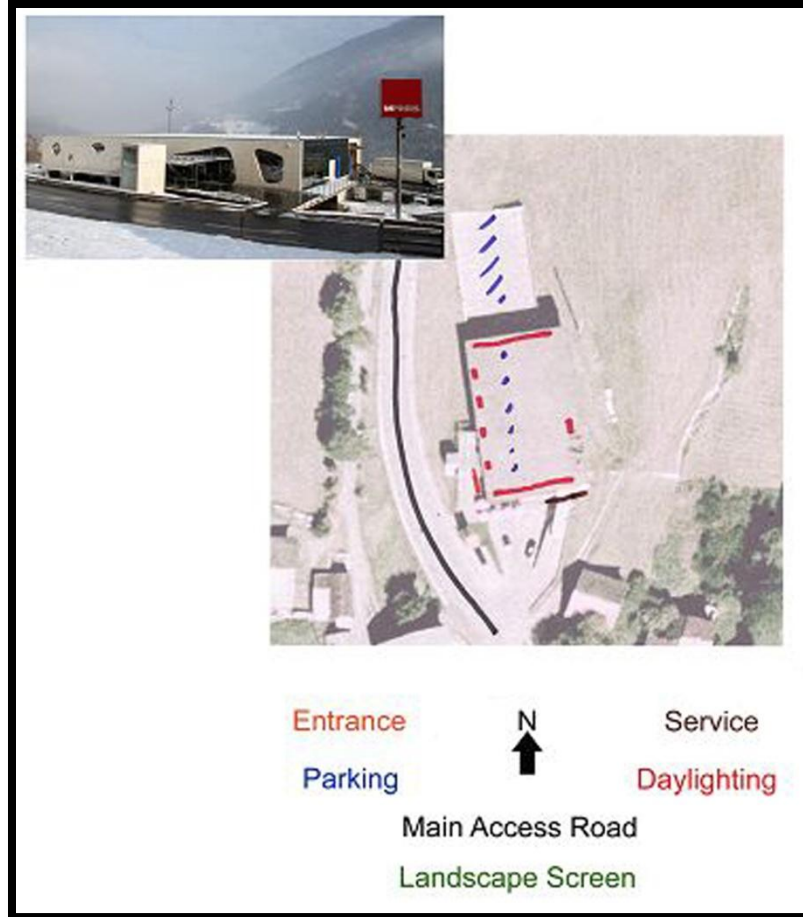

Figure 28: MPREIS Wennis
Images by Author and Courtesy of Google Earth™

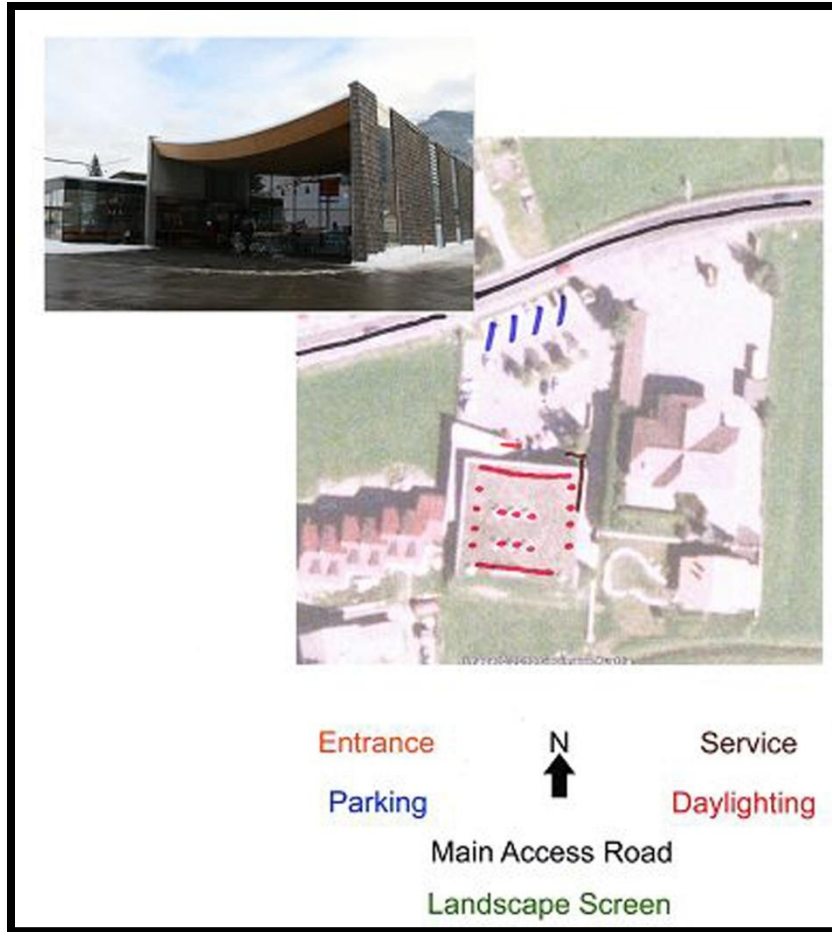

Figure 29: MPREIS Sillian
Images by Author and Courtesy of Google Earth™

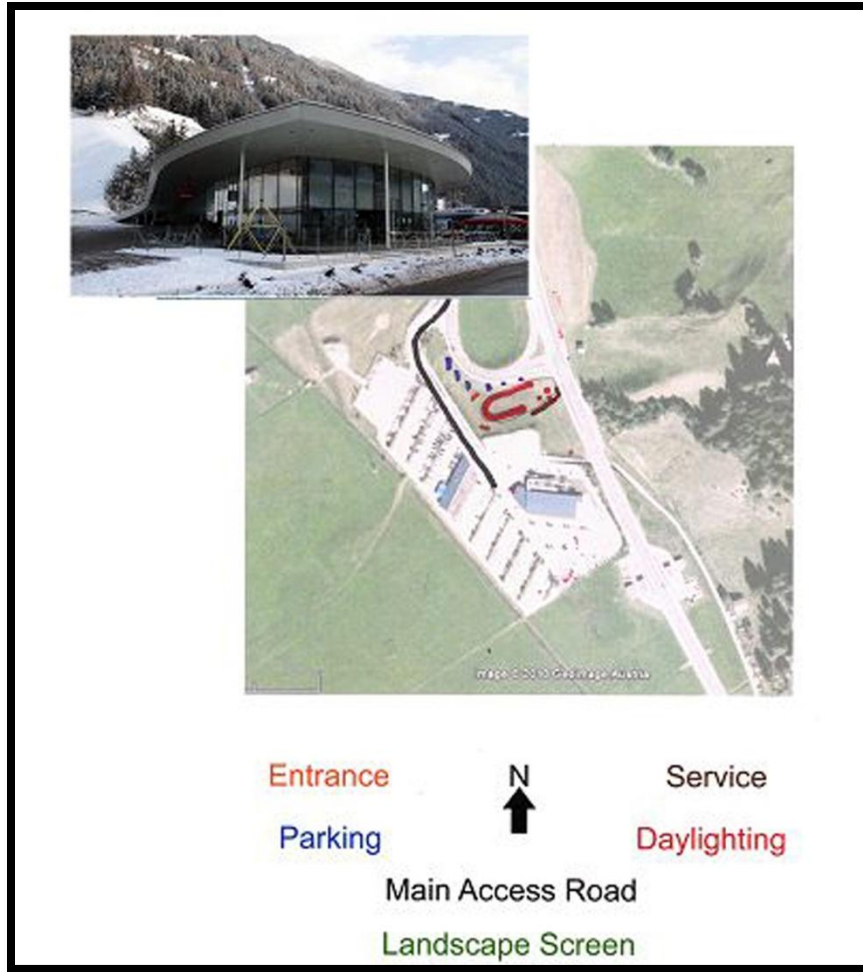

Figure 30: MPREIS Osttirol
Images by Author and Courtesy of Google Earth™

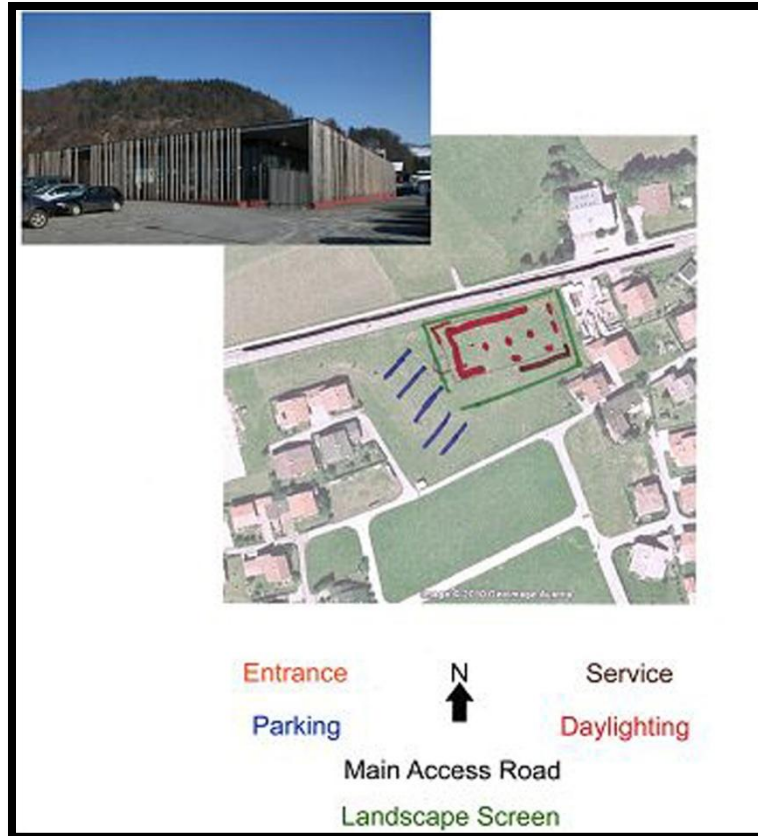

Figure 31: MPREIS Niederndorf
 Images by Author and Courtesy of Google Earth™

At the completion of the diagramming process combined with an incorporation of the information that had been gleaned during the precedent studies, a path with a set of constraints and goals had been delineated providing direction to begin the actual design of the form. The following sections form, modularity, structure, and components are non-linear synchronous elements of the design process leading to the completed design demonstrated in the final section of this chapter, Basic Module.

Form

At this point in the process, it was valuable to return to the programming elements that had been established earlier in the project:

- Buildings should make statement of “successful mercantile establishments”, but not appear too “upscale”.
- Modularity in design should be incorporated to minimize onsite construction and allow for repetition of the building form on other sites.
- The gross square footage of the building should be maximized for the site.
- Envelope thermal efficiency and air sealing should be paramount.
- Rainwater harvesting is incorporated with building.
- Green Roof should be implemented into design.
- Signage on buildings should be consistent in form but allow individual merchants expression.
- Daylighting opportunities should be fully investigated.

It was also too important to design within the constraints of the building codes and zoning regulations that applied specifically to this building form. The following is a sequential application of the pertinent code and regulations as prescribed by the Massachusetts Building Code¹⁶ and the Zoning Regulations of Sunderland, Massachusetts¹⁷

- Occupancy Group: Mercantile Group (M)
- Construction Type:
 - If largest building is 9,000 SF then all types permitted for one story unsprinklered.
 - If largest building is 12,500 SF all types except VB permitted for 1 story unsprinklered.
 - If largest building is 14,000 SF all types except IIB, IIIB, VB permitted for one story unsprinklered.
 - Building size could be expanded by up to 25% for the above-restricted types if frontage is expanded appropriately beyond the minimum requirement. This would bring the above values to include 11,250 SF for

Notes

¹⁶ (Massachusetts Building Code: Seventh Edition 2008)

¹⁷ (Sunderland Zoning Bylaws 1999)

VB; 15,625 SF for IIB & IIIB; and 17, 5000 SF for VA. All one story unsprinklered.

- Based on Sunderland zoning regulations (see below) buildings over 10,000 SF are not allowed, so the above calculations are actually moot.
- Based on the above it appears that all construction types with the exception of VB, which would be restrictive at 9,000 SF if a 10,000SF building is desired (unless frontage increase is involved) , can be used as unsprinklered, one story construction.
- If Construction type VB is preferred and Sprinklers are installed then minimum square footage becomes ample at 27,000 SF without addressing additional frontage.
- Restriction of 45' is not an issue for a one story Commercial Strip Mall.
- 5000 SF Buildings are permitted In C-1 Zone.
- 5–10,000 SF Special Permit required.
- Greater than 10000 SF not allowed.

It was of also of paramount interest that the new building form aesthetically joins the design successes of the two precedent groups. After some input from Eero Saarinen and Renzo Piano relating to roof forms, as well as revisiting the precedents, the form started to evolve through drawings, models, and photo studies.

Drawings

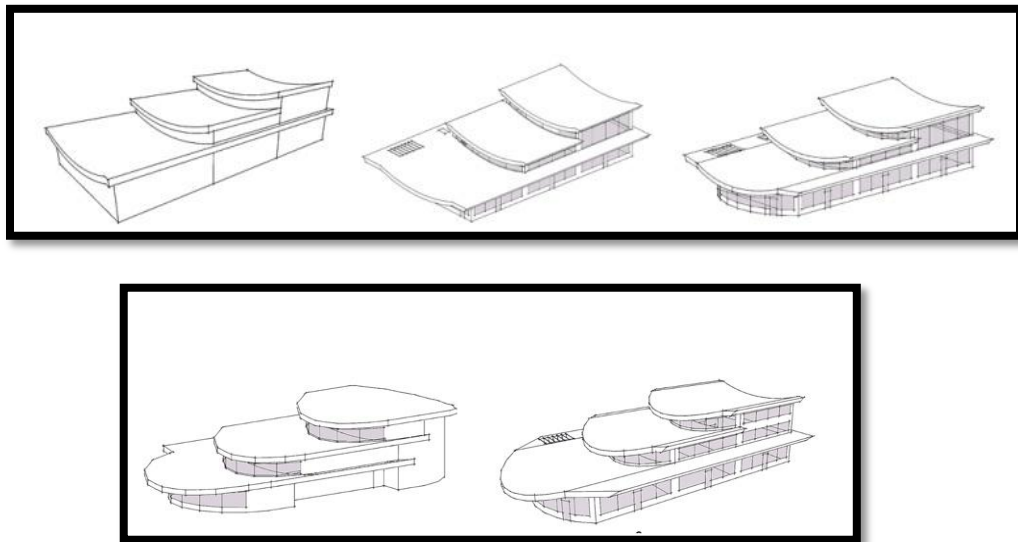

Figure 32: Concept Drawings 1 thru 5
Drawings by Author.

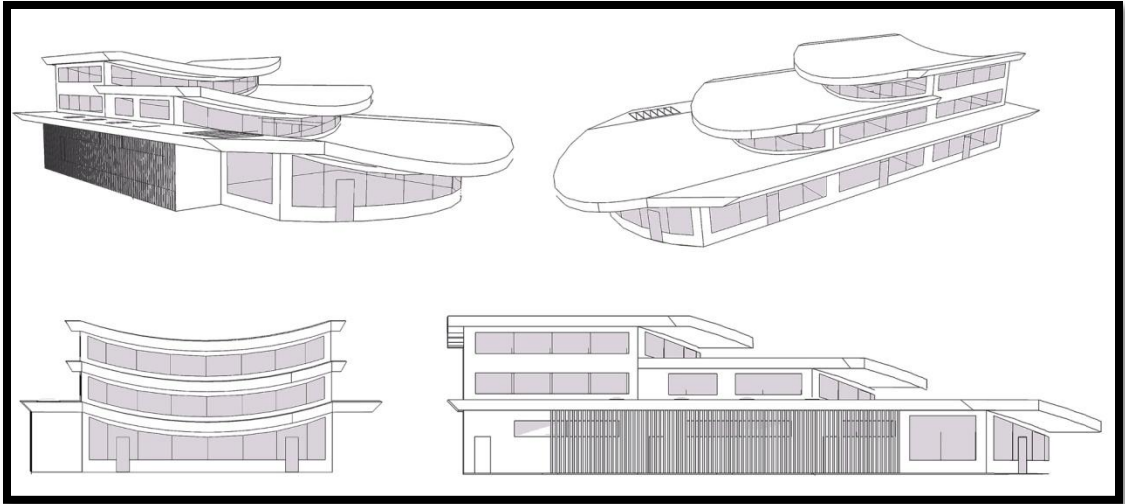

Figure 33: Perspective Views Concept 5
Drawings by Author

Models and Photo Studies

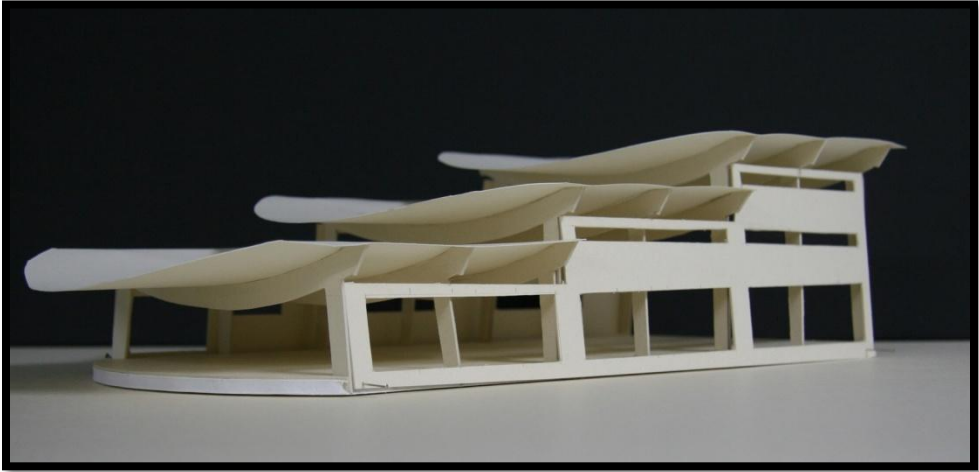

Figure34: Concept 7 Perspective
Model and Image by Author



Figure 35: Concept 8 Perspective 1
Model and Image by Author

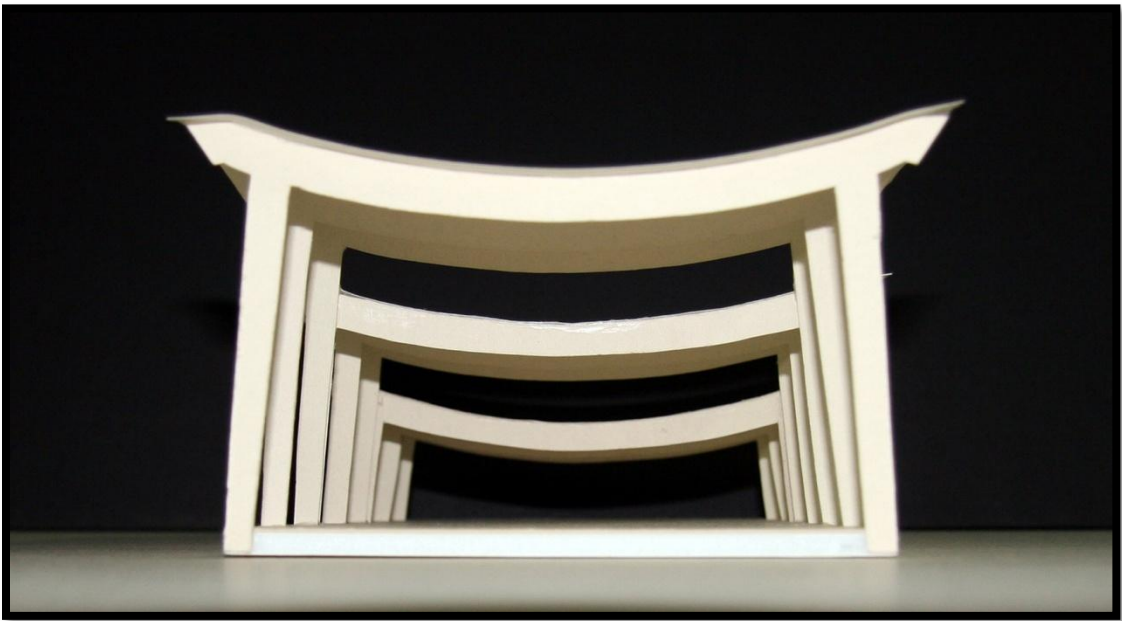

Figure 36: Concept 8 Perspective 2
Model and Image by Author

Finally, exotic roof forms were abandoned and a more direct orthographic form evolved.



Figure 37: Concept 9 Roof and Structure Study
Model and Image by Author

Modularity

Concurrently with the exploration of form, the concept of modularity was kept in the forefront. Initially the process involved duplications and extrusions of a single initial form, i.e. the leading single story section of Concepts 1 – 8. The result was unsatisfactory as the process was more of a first year studio push/pull exercise than a factory driven production process as can be seen in Figure 38.

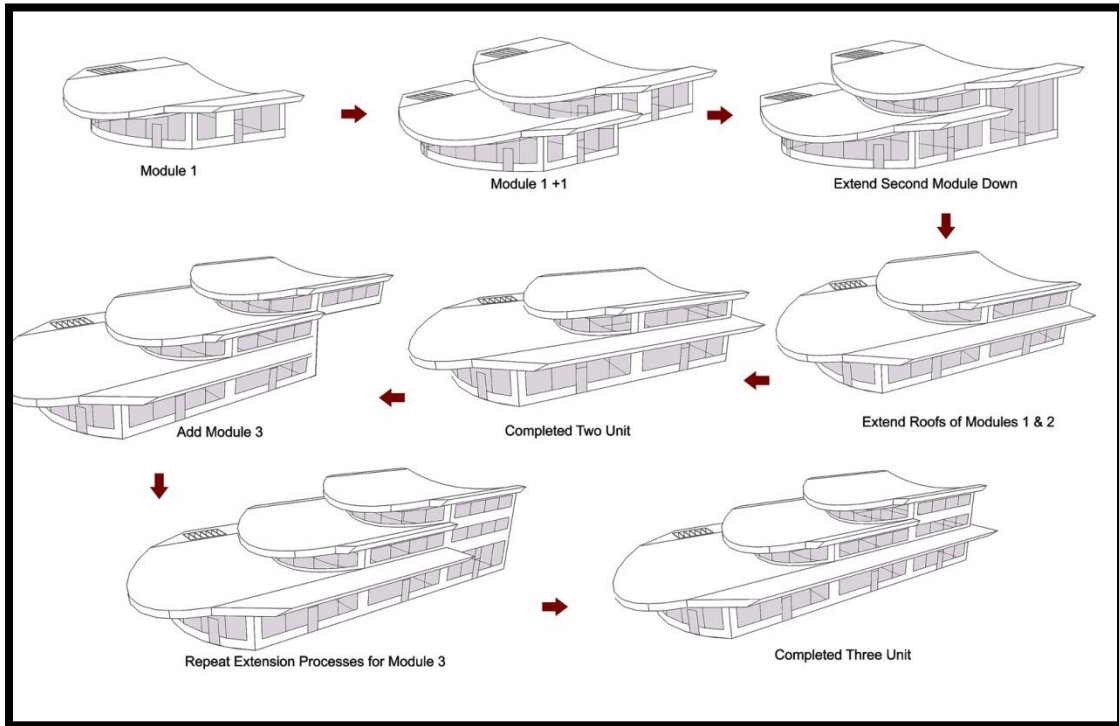

Figure 38: Initial Modularity Concept Drawings by Author

The process eventually involved into a true expandable unit modular concept based on Concept 9 that could be factory built and shipped to sites prepared with the requisite pads. This would optimize quality control and construction costs, while at the same time reduce the impact of weather on the construction schedule.

The metrics are based on:

- A plan grid of 4'x4'.
- A Central Component of 20'x36'.
- A rear component of 8'x20'.
- Two side components or wings of 8'x36' and 12'x36' along with two angled variations allowing for joining units in a radial fashion.

The components fit together in a variety of interlocking options, a kind of Leggos for developers, with decisions as to which finished assemblies to select for a project

based on site geometry constraints, desired building orientation, and the retail square footage program.

As an example, a Double Longitudinal Assembly offers dual opportunity: two stores of approximately 1600 SF, which is the size of a typical Dunkin' Donuts or one store of 3200 SF, which typifies a fair sized 7eleven. The combinations while not limitless are multiple.

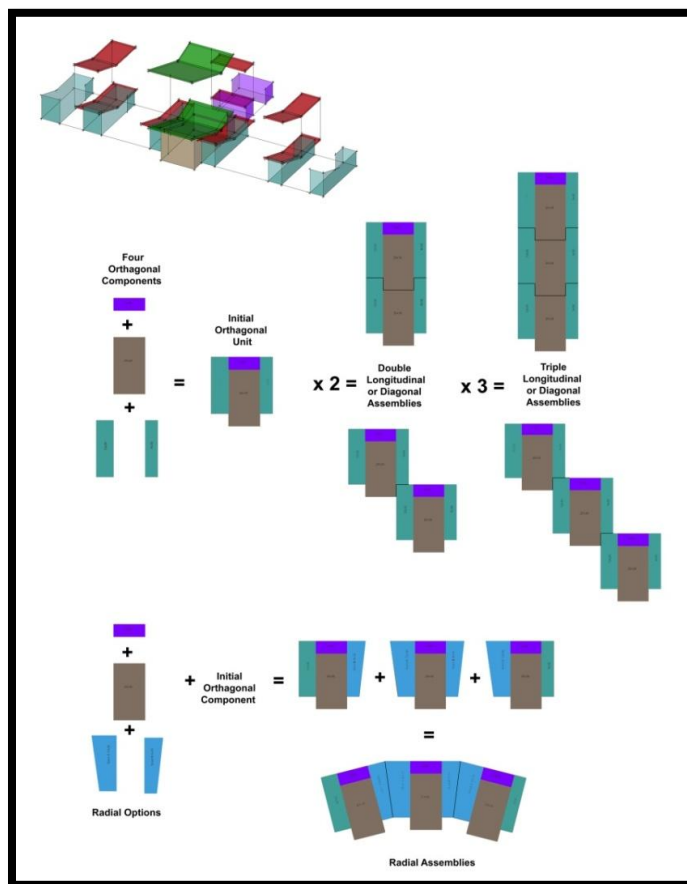

Figure 39: Modular Assembly Diagram
Mixed Media by Author

Recently, the National Research Council (NRC) appointed an ad hoc committee of experts to provide guidelines for improving the competitiveness and productivity of the U.S. construction industry. The committee was to identify and prioritize technologies, processes, and deployment activities that have the greatest potential to advance the productivity and competitiveness of the U.S. construction industry over the next 20 years. The committee identified five areas to improve the efficiency and productivity of the construction industry, including “Greater use of prefabrication, preassembly, modularization, and off-site fabrication techniques and processes.”¹⁸

The advantages of these techniques and processes are in perfect harmony with this project as they offer the opportunity of lower project costs, shorter schedules, improved quality, and more efficient use of labor and materials. The process incorporates exemptions from weather conditions, improved quality control, easier supervision of labor, more ready access to tools, and fewer material deliveries. The jobsite environmental impacts are diminished because of reductions in material waste, air and water pollution, dust and noise, and overall energy costs (although prefabrication and related technologies may also entail higher transportation costs and energy costs at off-site locations). Project schedules are compressed as a result of altering the workflow sequence, e.g. allowing for the assembly of components off-site at the same time foundations are being poured on-site). There is a reduction of conflicts in work crew scheduling in a single location simplifying the sequencing of trades along with reducing the requirements for on-site materials storage, and fewer losses or misplacements of

Notes

¹⁸ (Modular Building Institute 2010, 1)

materials. Workers safety is improved because of reduced exposures to inclement weather, temperature extremes, or hazardous operations, e.g. components traditionally constructed onsite at heights can be fabricated off-site and then hoisted into place using cranes.¹⁹

Finally, while the opportunity exists to incorporate “green technologies” in both on site and factory based construction there is a distinct advantage in factory-based assemblies in the area of resource efficiency. There is the potential to make a significant difference to the amount of waste produced. Modular construction capitalizes on the ability to move product in controlled manufacturing conditions with tight inventory control and project schedules and is inherently waste conscious. This is supported by The U.S. Green Building Council (USGBC) who recognizes the advantages of prefabrication and off-site construction techniques. In its Leadership in Energy and Environmental Design (LEED) for Homes rating system, the USGBC awards points under its materials and resources sections MR 1.2 and MR 1.3.²⁰

Projects with a precut framing package (e.g. modular homes, kit homes) are awarded MR 1.2 and MR 1.3 (detailed framing documents) automatically.²¹

In Europe, the concept of modularity and prefabrication is slightly more mainstream than in the United States, as evidenced by companies such as Rubner in

Notes

¹⁹ (Modular Building Institute 2010, 8)

²⁰ (Modular Building Institute 2010, 9, 10)

²¹ (U.S.Green Building Council 2010, 14)

Italy²² or Baufritz in Germany²³. It is a concept that is antithetical to the construction industry ingrained with traditional methodologies and practices, but the mounting pressures of labor costs, health issues, energy costs, and environmental awareness will foster an increased acceptance of these practices both here in the United States and in Europe.

Structure

Dovetailing with the exploration of form and incorporation of modularity was structure. The choices for structural elements influenced the form in terms of proportion (form aesthetics related to element sizing which respond to loads), incorporation into modularity (simple size variability of the structural selection), and energy performance metrics.

The structure is a combination of insulated concrete pad, timber columns, glulam girts, steel frames, and SIPS roofs and walls.

The concrete pad was an economic and thermal choice. It offered the benefits of:

- Simple construction and insulation techniques allowing PassivHaus standards of insulation (R-30, i.e. 8 inches of sub-slab EPS insulation) at this building surface, which will in all likelihood be the longest surviving of all the building components.
- Insulated stem walls (R-value similar to slab) vary in required depth based on frost penetration from region to region reducing material requirements.
- Utilizing concrete with fly ash to reduce cement use and embodied energy.

The benefits to fly ash concrete are that it reduces the energy-intensive manufacturing of other concrete ingredients, leading to savings in both energy usage and

Notes

²² <http://www.haus.rubner.com/en/>

²³ <http://www.baufritz.com/de/>

emissions of greenhouse gases. Use of a ton of fly ash to replace a ton of other manufactured materials saves enough electricity to power an average American home for 24 days, and reduces carbon dioxide emissions equal to two months' use of an automobile. Additionally, conserving landfill space is an important consideration. Every ton of coal combustion products that is used to improve our nation's highways and buildings is a ton that is not deposited in a landfill, saving the same amount of space in the landfill that the average American uses over 455 days.²⁴

Glulam and Timbers were aesthetic choices as well as controlling thermal bridges at envelope penetrations. As the design intended exposed structural elements the selection of the inherently pleasing qualities, warmth and color, which finished wood offers was not a difficult one. Additionally, the availability of prefinished and packaged correctly sized elements available directly from manufacturers spread across the country, diminishing transportation costs is an attractive feature of the product. The through wall penetration of the design also reduces thermal bridging at these points since wood possesses an R value of approximately 1 per inch which is superior to either concrete or steel and a much friendlier installation. Sizing the elements was based on Massachusetts Building Codes for the central region of the state snow load (55 psf) coupled with dead loads derived from figures for an assembly of an extensive green roof over a 9" Structural Insulated Panel System Assembly (30 psf) or a standing seam sheet metal roof over 9" Structural Insulated Panel System (10psf).

Notes

²⁴ (Headwater Resources 2005, 10)

Structural Insulated Panel System (SIPS) are valued for their robust thermal properties and air sealing abilities, structural capabilities (allowing their use as bearing and shear walls when specifically assembled) , and with a dimensional standardization that works perfectly with modularization. The availability of a variety of panel materials e.g. drywall, oriented strand board (OSB), or alternate finished materials, e.g. stainless steel ceiling material, is also a versatile and potentially cost saving feature of this component. Paramount in the envelope is the incorporation of two qualities. First, air sealing which given slab foundation and SIPS superstructure coupled with appropriate detailing between SIPS and foundation and SIPS and window and door penetrations is far easier to achieve than with more traditional construction techniques. Second, is R-value. It is a desirable goal to also direct the R-values of roof and walls to PassivHaus minimum standards (Roof, R-50; Walls, R- 40). A 9” SIPS employing extruded polystyrene insulation has an insulating value of approximately R-40 along with the systems inherent superior air sealing qualities. These metrics contrasted with code based mandates of R-7 (wall) R-19 (Roof) minimums²⁵ without any air sealing mandates represents enormous improvements in thermal and air sealing abilities which eventually become energy savings.

The final components are steel frames. These are installed on the tops of glulams that if allowed to directly support the roof panels would not have permitted daylight from clerestory windows to enter the interior space, as the glulam itself would have been an

Notes

²⁵ (Massachusetts Building Code: Seventh Edition 2008)

opaque obstruction. These frames transfer the roof load forces directly to the glulams beneath and are sized via identical parameters.

The following drawings illustrate the positioning and use of these elements first in plan and then in perspective.

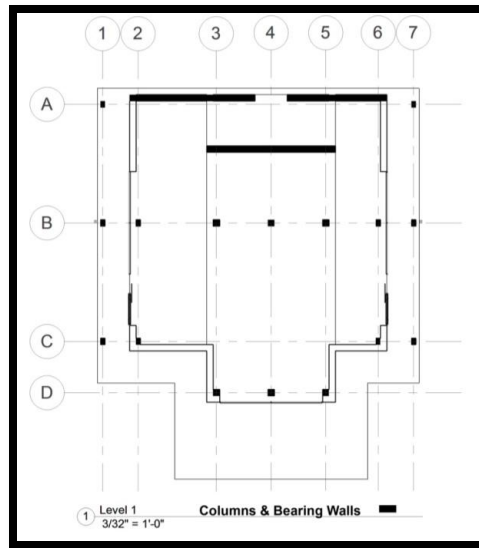

Figure 40: Columns & Bearing Walls - Plan
Drawing by Author

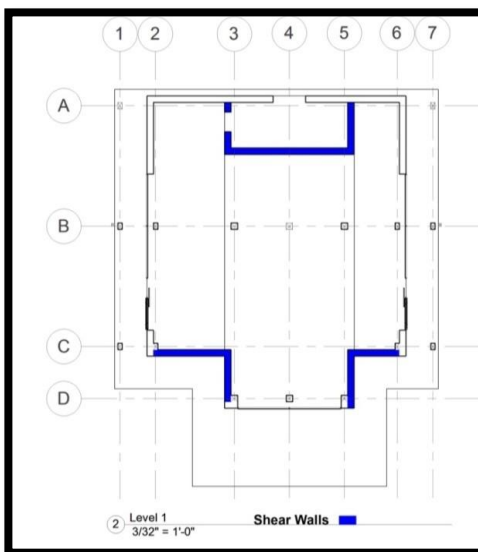

Figure 41: Shear Walls- - Plan
Drawing by Author

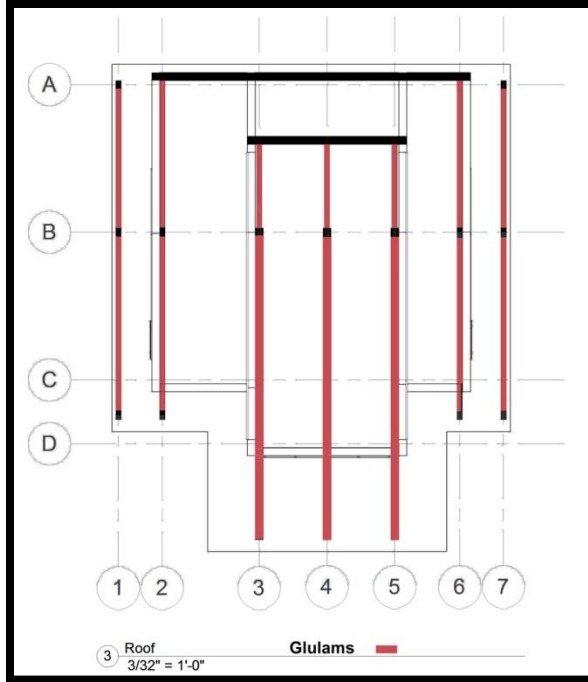

Figure 42: Glulams - Plan
Drawing by Author

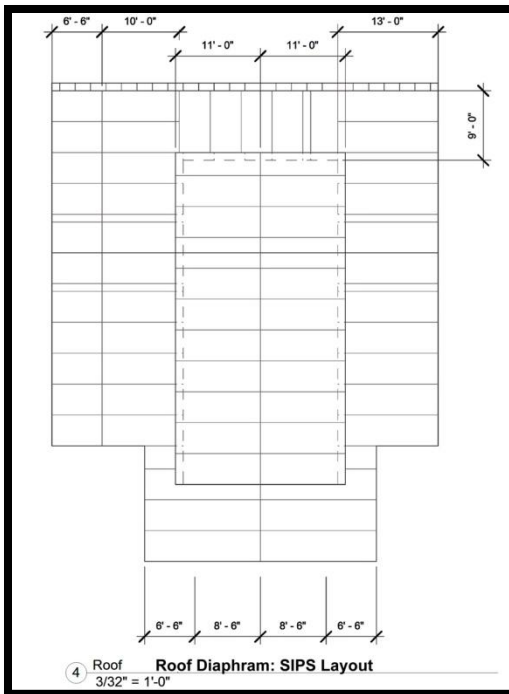

Figure 43: Roof Diaphragm: SIPS Layout – Plan
Drawing by Author

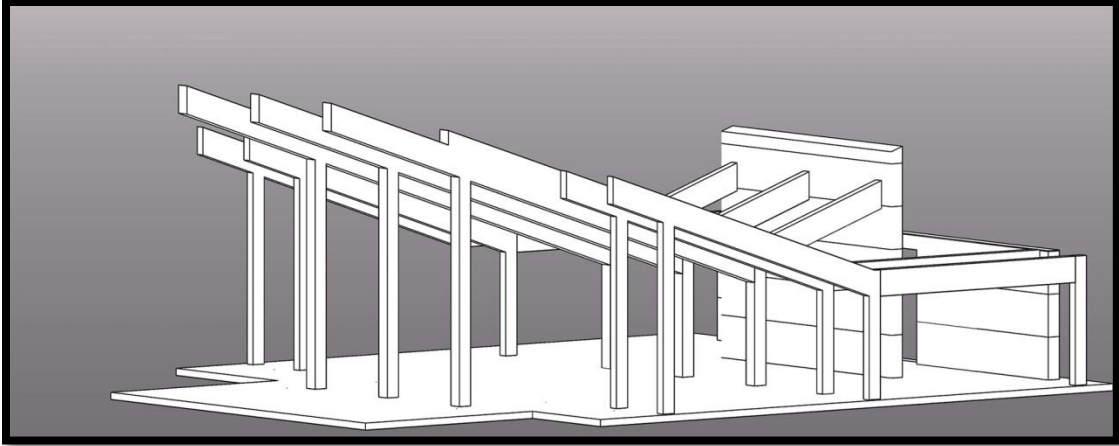

Figure 44: Columns, Glulams, Bearing Walls
Drawing by Author

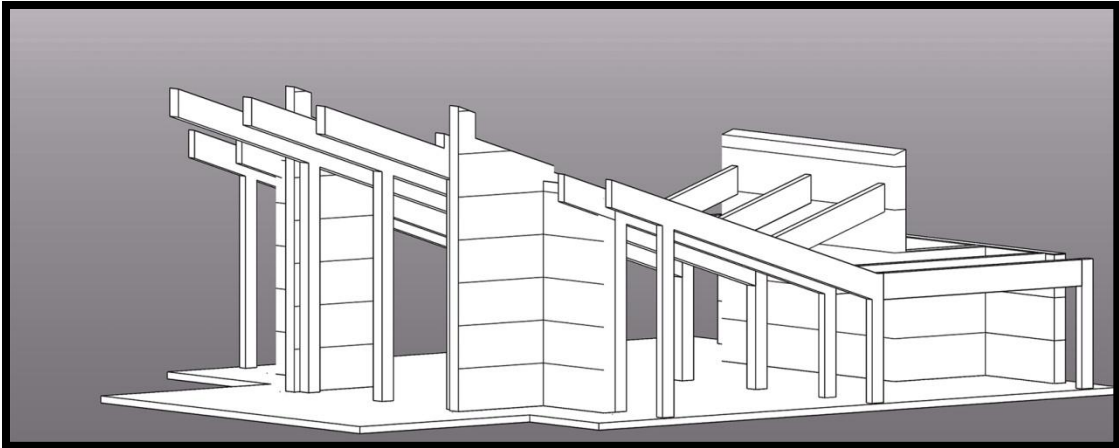

Figure 45: Shear Walls
Drawing by Author

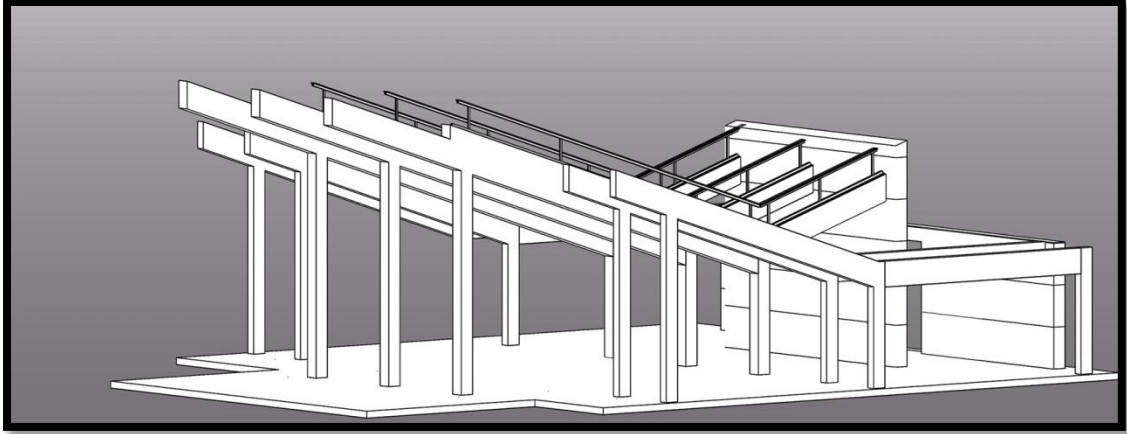

Figure 46: Steel Frames
Drawing by Author

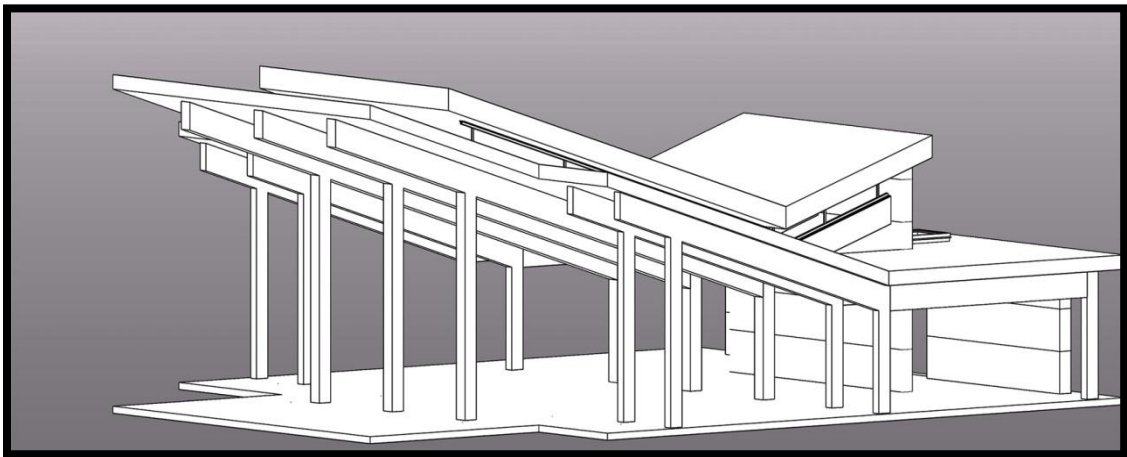

Figure 47: SIPS Roofs
Drawing by Author

Components

Several elements of the design components have been addressed at this point, as they were components that contributed to the structure of the design, i.e. insulated concrete pad, glulam and timber posts, SIPS, and steel frames. It would be a formidable task to illustrate in detail all the components that were incorporated into the design. Several of the key elements extracted from the wall section will be illustrated (see Figure 48), but the remainder shall have to suffice solely with text.

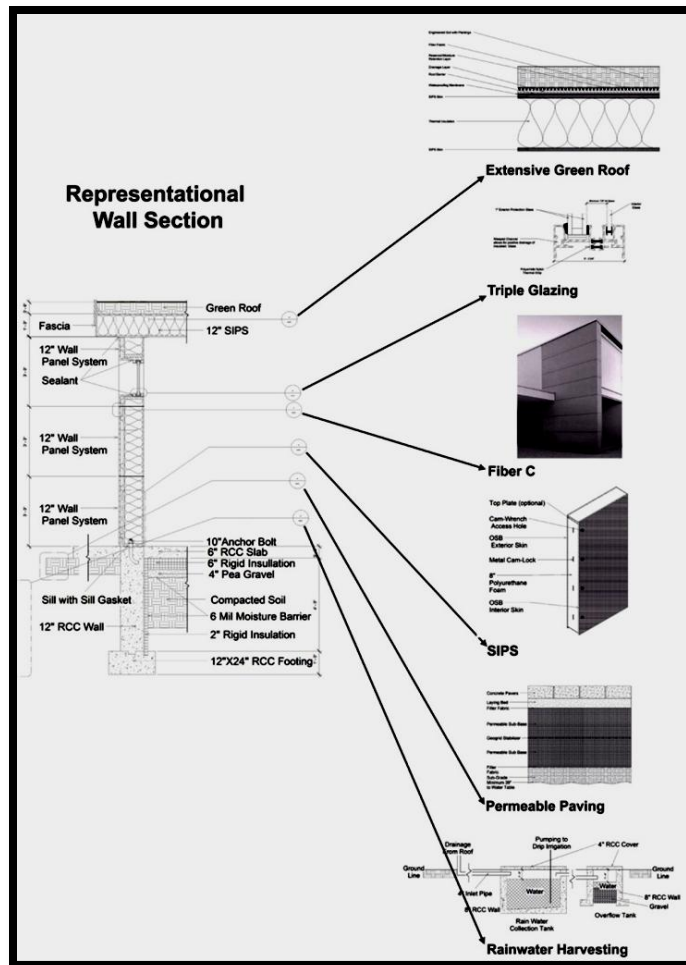

Figure 48: Representational Wall Section with Details
Drawings by Author

Extensive Green Roof

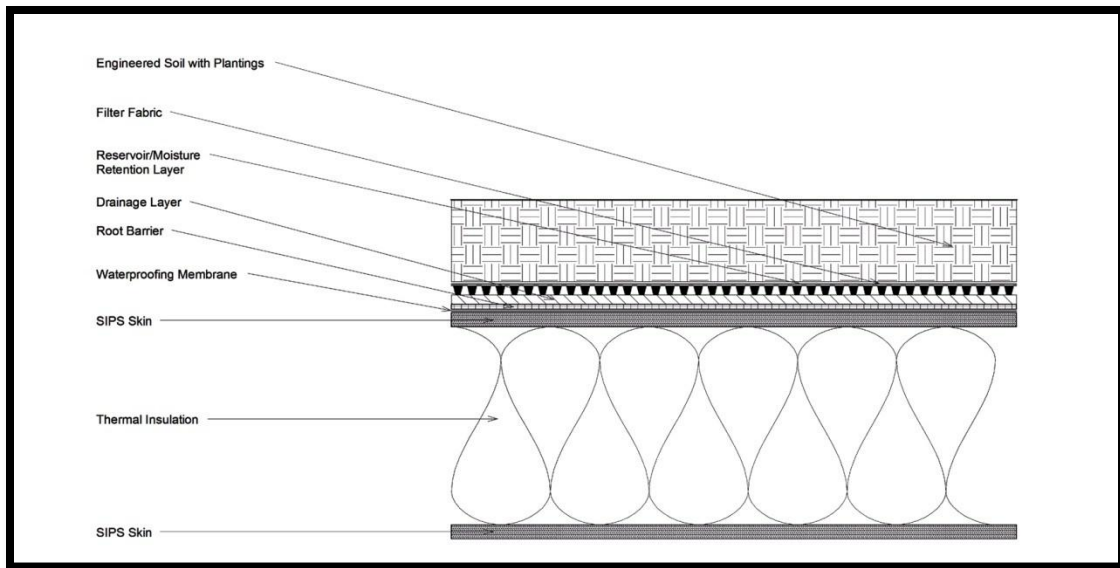

Figure 49: Extensive Green Roof Detail
Drawing by Author

The roofs of the design are a combination of extensive (not intensive which requires more substantial structure along with more maintenance) green roof and reflective roofing materials. Both surfaces reduce the heat sink contributions and the Green Roof will contribute to site water management. As an element, a Green Roof is an expensive addition to a project (see Chapter 5, Economics) and its justification must fall under the category of branding or image projection. There is probably not a more obvious statement of a projects subscription to Green or Sustainable Design than a Green Roof, but its return must be justified by intangibles such as branding rather than energy saving metrics.

Triple Glazing

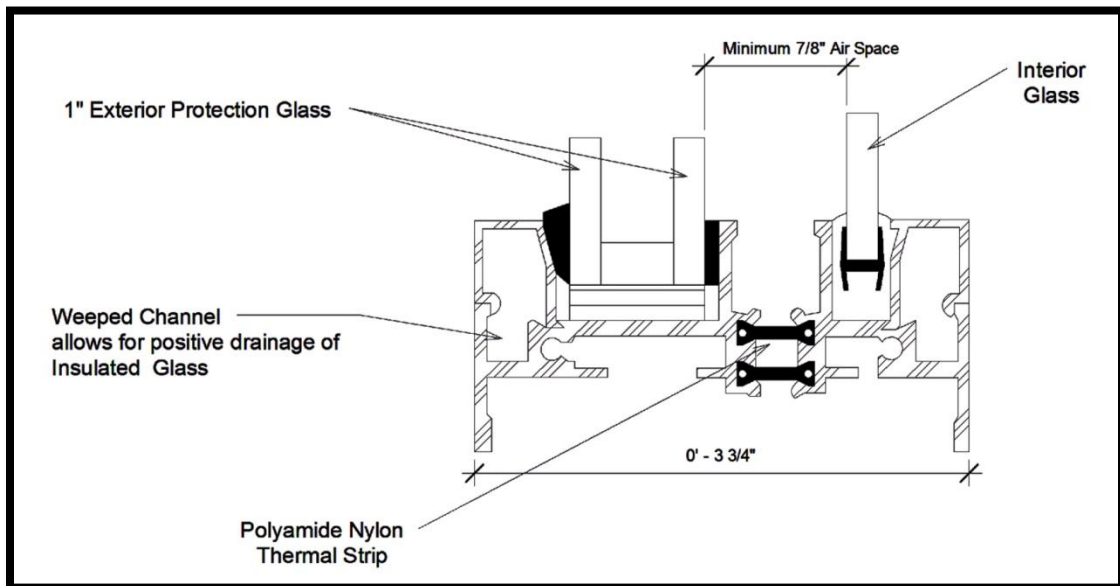

Figure 50: Triple Glazing Detail
Drawing by Author

Triple Glazing is the major element completing the envelope and it is of importance that it supports rather than subtracts from the success of the envelope. All glazing, whether awning type casement or storefront type walls have the capabilities of providing a variety of functions; i.e. natural ventilation through operability, improved interior climate control with factory installed operable shades, and acoustic buffering. The R- value of a triple glazing is R-7, which is substantial increase over the standard double gazed insulated glass unit of R-2. Although the cost of these systems is decreasing as production and volume increase, the economics of this system is problematic (see Chapter 5, Economics).

Permeable Paving

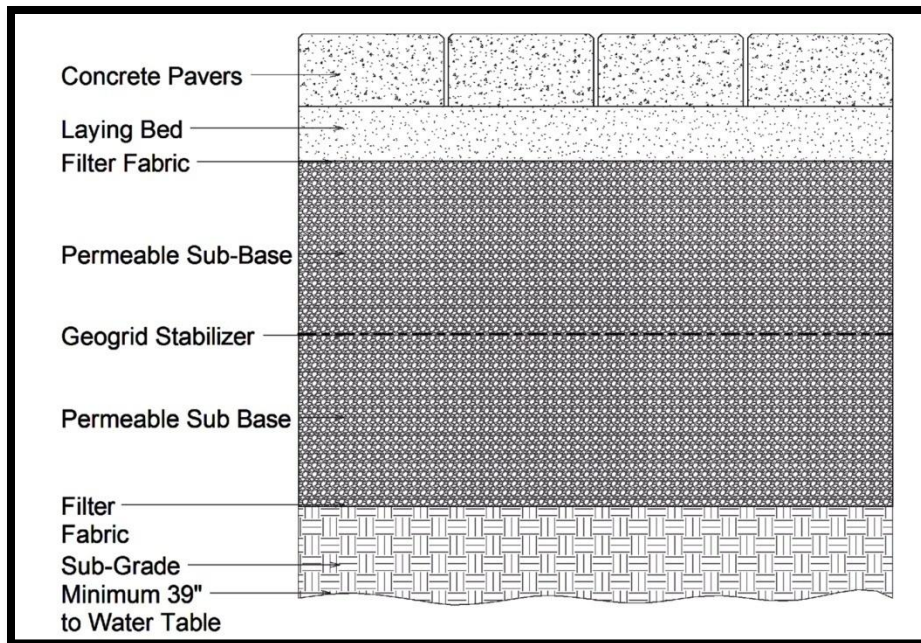

Figure51: Permeable Paving Detail
Drawing by Author

Permeable paving techniques is used on all surfaces excepting entrance aprons where because of durability issues asphalt will be used. All striping for parking will be done with color-impregnated pavers mitigating the use of traffic coatings and their inherent volatile organic compounds (voc) releases into the atmosphere. The color of the pavers is to be lighter than asphalt with a higher reflectivity coefficient reducing the heat island effect. Finally, the products strongest characteristic is that it dramatically reduces the substantial runoff that is the nature of impermeably paved expanses.

It should also be mentioned that the design calls for similar paving material, but set in mortar for all walkways underneath the designs canopies. This elevates the walkways by 6" (ADA ramps as necessary) and creates a flush threshold with the retail interiors.

Rainwater Harvesting

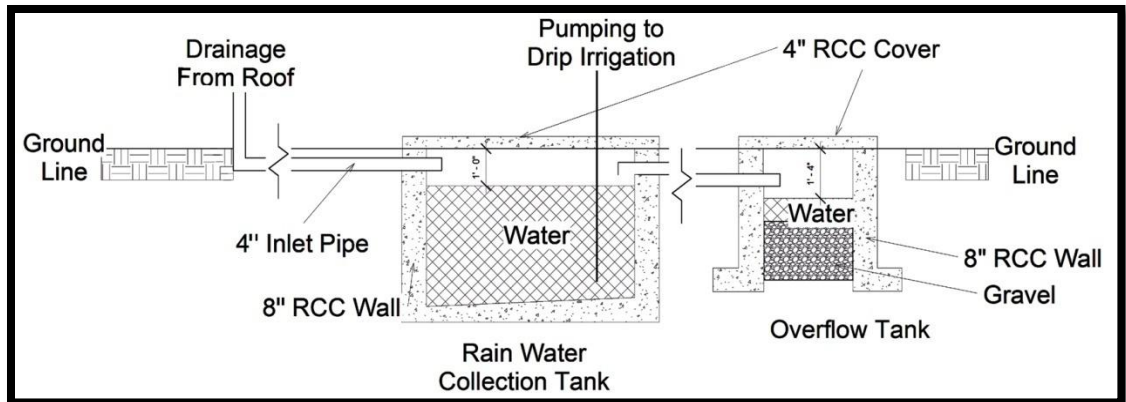

Figure 52: Rainwater Harvesting System Detail
Drawing by Author

A Rainwater Recovery System is used in conjunction with the roof gutter system. The system's function is twofold. First, it helps to manage excess storm water on the site and reduce run off. Second, it stores water in the underground cistern where the water is filtered and then distributed by a drip irrigation system to the Green Roofs and site planting during periods of dry weather and rain shortages.

Additional Systems

Daylighting strategies including clerestories, skylights, 16' storefront glazing assemblies, and reflective stainless steel ceilings are incorporated into the design and which will, perhaps surprisingly, be discussed in Chapter 5, Economics.

Other systems, assemblies, or technologies that are incorporated into the design are:

- Lighting
 - All areas not engaged with direct sales have occupancy as well as daylight sensors.
 - All areas engaged with direct sales have daylight sensors.
 - All lighting is CFL, T-5, or LED

- Electrical
 - Each unit has separate service and meter.
 - Each unit has an Electrical Dashboard, e.g. The Energy Detective to allow for tenant monitoring and live feedback of electricity usage. Note: The Energy Detective Model 5000 cost is \$240.00.
 - Each unit has a chase to access the roof and the exterior to allow for easier connectivity with future solar energy sources (Solar or PV Panels or Integrated Material Systems) when efficiency and costs or government subsidies move the systems more comfortably into the realm of economic feasibility.
 - Incorporated into each tenant lease will be the requirement of all appliances installed by the tenant to be Energy Star rated

- Plumbing
 - All toilets are dual flush.
 - All faucets are low flow except as required for food preparation systems.

- Heating
 - Each unit has a separate heating system.
 - Systems are zoned as appropriate for tenant.
 - Boilers are condensing hydronic units with hot air delivery systems and allow integration with future solar hot water as well as integration with more sophisticated Dashboard System such as Agilewave's The Resource Monitor (when they become affordable).
 - Heating system is supplemented by passive solar techniques; i.e. thermal mass of slab, positioning of the buildings on the site referencing glazed surfaces, and material colors regarding reflectivity or absorption qualities. This allows reduction of boiler sizing reducing expense.
 - Fuel source for system will be propane.
 - Each unit is required to incorporate Energy Recovering Ventilator (ERV) to further reduce fuel consumption.
 - Hot water will be on demand as part of the condensing boiler unit.
 - Space provisions are allowed for in the Mechanical Rooms to allow for addition of solar hot water storage tank should eventual incorporation of this system become a feasible economic reality.

- Cooling and Ventilation
 - Each unit has a separate system.
 - Reduction of the period of time that the air conditioning will be used especially in the "swing seasons" (spring and fall) is accomplished with the passive ventilation techniques of operable windows on all sides, operable shading devices at all east, west, and south windows, and stack ventilation techniques.

- Although the air conditioning system will still have to be sized for the extreme days of summer to maintain occupant comfort, its operating time and therefore electricity usage will be lessened.
- Whether an active ventilation system will be required is of interest. Certainly, in a residence or business with tight envelopes, they are necessary to allow for fresh air requirements to be met; but in busy retail environments of this size where the doors to the exterior are repeatedly opened (even rapid reaction sliding doors allow some air exchange between conditioned and unconditioned space) a question arises as to whether Indoor air Quality (IAQ) is inadequate. The only determination would be a measurement for each tenant after occupancy. Until more information is obtained on the subject the recommended ducting is installed in each unit so that if need arises installation would be simplified. Each tenant would be required to test; and if appropriate comply and integrate an Active Ventilation System. This would be a provision of the lease.

The Basic Module

The assimilation of form, modularity, structure, and components has resulted in a completed structure that incorporates and integrates all of the elements into one entity. The illustrations that follow represent the basic orthogonal unit of this project (see Figure 54). It is demonstrated first in drawings, then in photographs of a model.

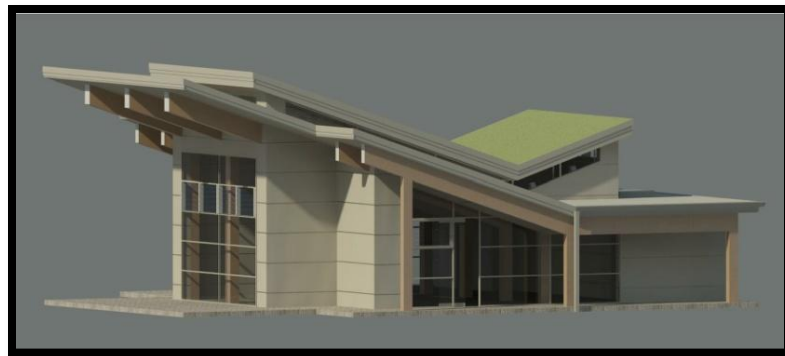

Figure 53: Basic Orthogonal Unit
Render by Author

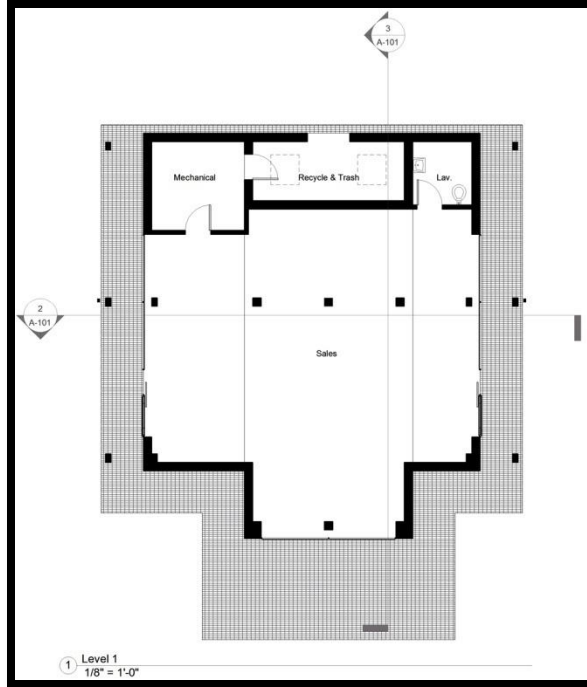

Figure 54: Level 1 Plan
Drawing by Author

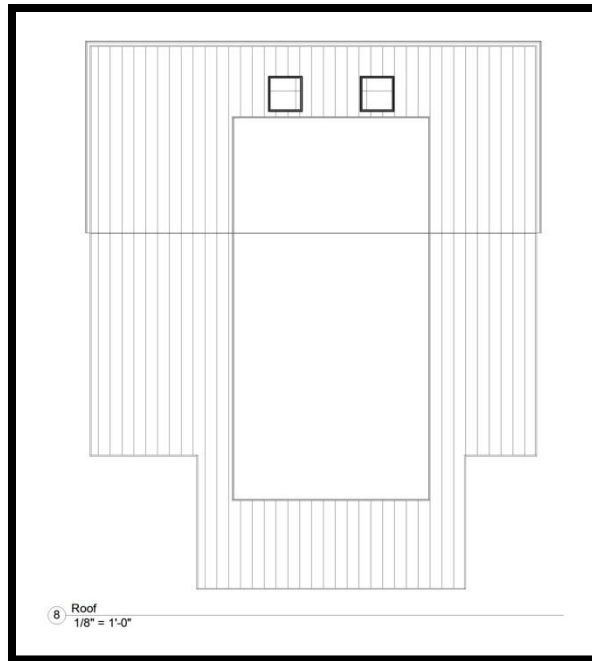

Figure 55: Roof Plan
Drawing by Author

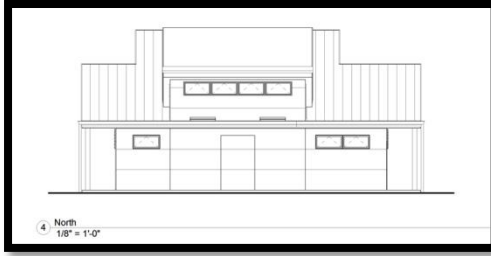

Figure 56: North Elevation
Drawing by Author

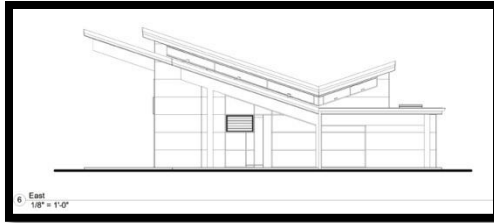

Figure 57: East Elevation
Drawing by Author



Figure 58: West Elevation
Drawing by Author

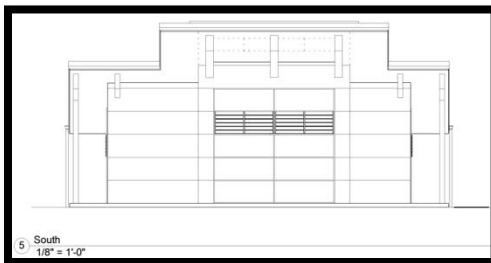

Figure 59: South Elevation
Drawing by Author

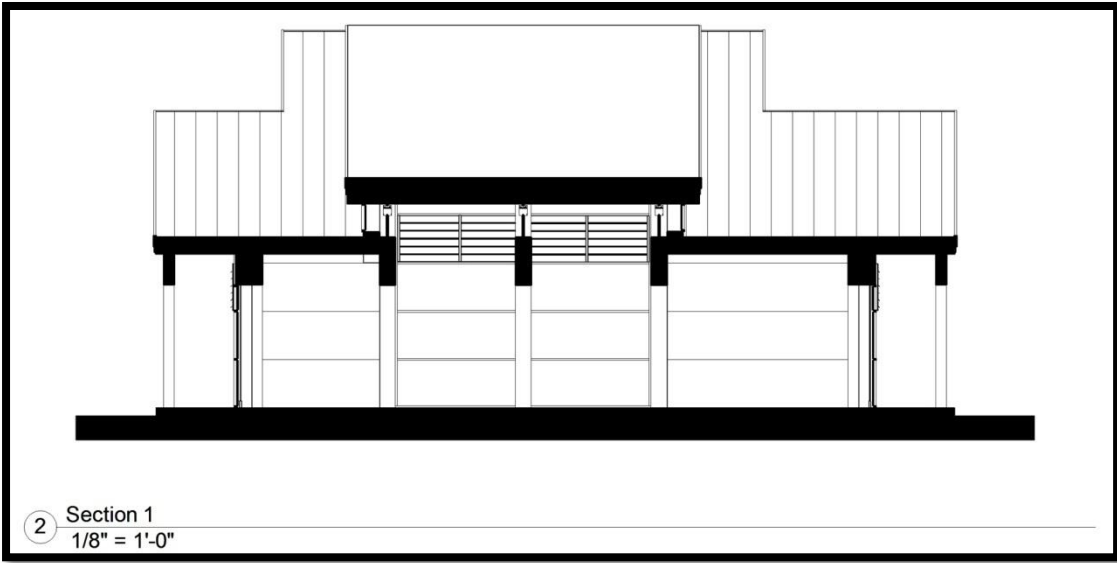

Figure 60: Section 1
Drawing by Author

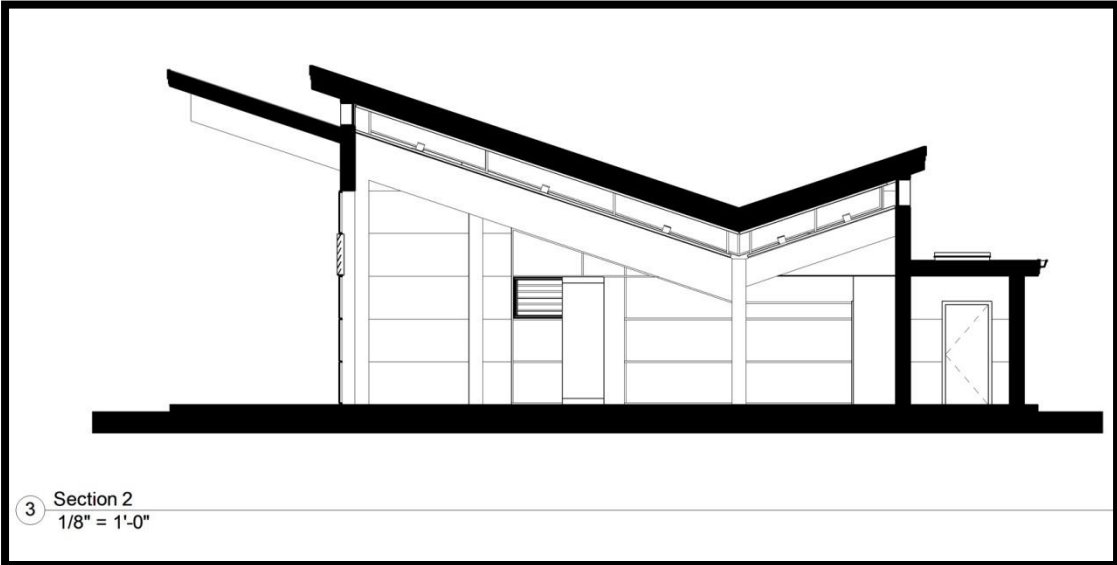

Figure 61: Section 2
Drawing by Author



Figure 62: Concept 9 Model: View 1
Model and Image by Author



Figure 63: Concept 9 Model: View 2
Model and Image by Author

CHAPTER 4

SITE

Procedure

Upon completion of designing the unit module and the development of the modularity concept, it is now possible to view the additive forms when the modularity concept is applied. Figures 64 and 65 illustrate two sample plans and Figures 66 through 68 illustrate additional configurations through renders of digital models.

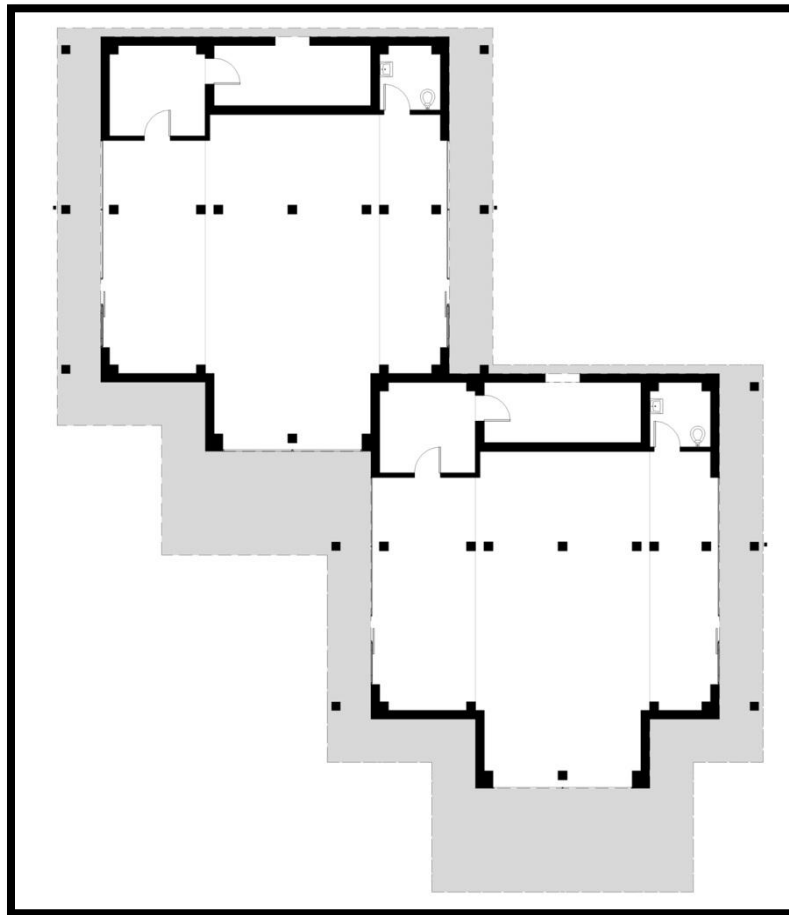

Figure 64: Double Diagonal
Drawing by Author

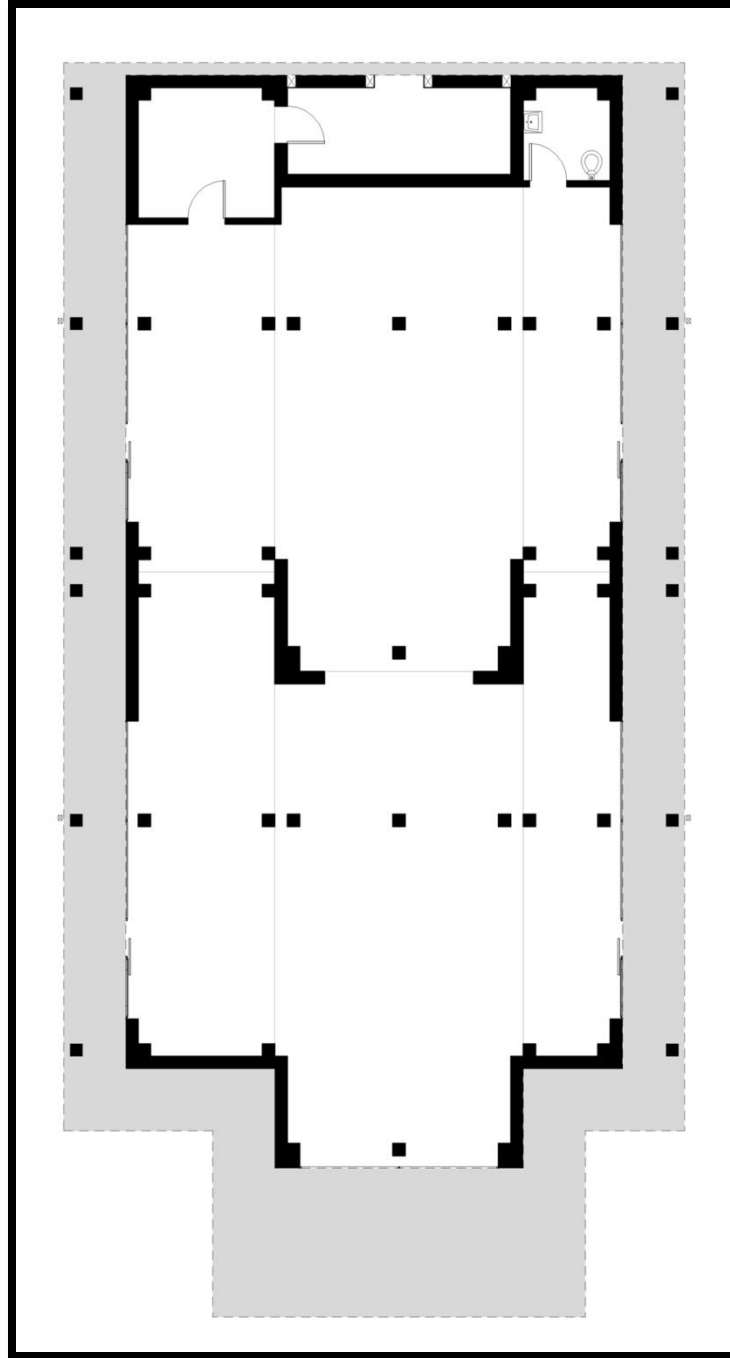

Figure 65: Double Longitudinal
Drawing by Author



Figure 66: Double Diagonal Perspective
Render by Author



Figure 67: Triple Diagonal Perspective
Render by Author



Figure 68: Triple Longitudinal Perspective
Render by Author

Now with the design form in mind it is possible to demonstrate a real world scenario utilizing this modular concept. To that end a site is selected and to an empty plan of that site all zoning regulations are applied, e.g. setbacks, buffer zones, parking space requirements, landscape requirements, and public space requirements. Additionally, all the building limitations are applied, e.g. individual building square footage maximums and total maximum built square footage to site square footage limitations.

After the site constraints are established, the assemblies are selected and constructed that best maximize the buildable square footage for the site. As was discussed in the section on modularity those decisions as to which finished assemblies to select for a site are based on site geometry constraints, desired building orientations, and the retail square footage program.

The final step is not as formulaic as the previous ones. It is now necessary to organize and design a plan that incorporates: public transportation, access to building services, snow removal, signage site lighting, public space, circulation, private exterior space, and all the other myriad of components that constitute a successfully designed project. Success is determined not only from a pragmatic perspective, but also from the

perspective of an aesthetic that must contribute in all senses to the community and still perform as expected.

Context

The site is a 2.155 acre, irregularly shaped parcel, located on a major access road, Rte. 116, in Sunderland, Mass. It has proximity to large residential apartment complexes, proximity to nearby suburban residential developments, and adjacency to public transportation (our PVRTA).

The site is currently host to three buildings of 2400 SF, 2500 SF, and 8240 SF for a total of 13,140 SF of retail. After all applicable zoning setbacks, buffer zone requirements, planting requirements, public plaza requirements, and pedestrian pathway requirements are met; these restrictions translate into the following metrics of square footages for the site:

- Gross Area of Site: 2.155 Acres (93,817 SF).
- Gross Area available for Building and Parking: 1.498 acres (65,266 SF).
- Gross Area available for Building: 1.215 acres (52,940 SF).

It is of import to recognize the positive aspects of the existing site and the buildings as they have combined to realize a successful entity for over forty years and Hornbeck's mandates must be applied. The positive attributes for the developer are:

- Significant appreciation in property value. The original cost of land and buildings of \$160,478 in 1974 has escalated to an assessed value of \$1,279,000 in 2009, almost 800%.
- The buildings and grounds, as evidenced by their conditions, have received the most minimal of maintenance, therefore controlling maintenance costs.
- Occupancy is typically 90-100% with national chains (7-11 and Dunkin Donuts) at opposite ends and long time local merchants occupying the remainder.
- Income from the property is consistent and leasing is long term.

The positive attributes for the tenant are:

- The location is on a major access road, Rte. 116.
- There is proximity to large residential apartment complexes.
- There is proximity to nearby suburban residential developments
- There is adjacency to public transportation, Pioneer Valley Transit Authority (PVRTA) Bus Stop.
- Access to the street is from the main route with substantial shoulders and turning lanes assuring ease of entrance for both cars and trucks.

The positive attributes to the consumer are:

- Convenience of location for access by car, truck, bus, or bicycle.
- There is a broad selection of mercantile types to select from:
 - Fast Food: Dunkin Donuts.
 - Local Restaurants (lunch and dinner; take out): Frontier Pizza.
 - Dance Studio: Cindy's School of Dance.
 - Gift Shop: Mt. Sugarloaf Treasures.
 - Vacant
 - Liquor Store: The Spirit Shoppe.
 - Laundromat: Sunderland Suds.
 - Local Restaurant (breakfast and lunch): Dove's Nest Restaurant.
 - Convenience Store: 7-11.

On the single level of economic profitability, this Commercial Strip Mall works extremely well. As was noted in Chapter 1, The Commercial Strip Mall is a style of building that originated in the late nineteenth century and has experienced relatively little evolution over the past one hundred plus years. The three buildings here are archetypical of the type. There inadequacies are numerous:

- They are all single story, low roofed with the three predominant roof style variations for the genre, i.e. flat with parapets, mansard, and gabled.
- This Strip Mall was built in three phases with the buildings separated by alleys wide enough for vehicles or dumpsters without any effort to connect the buildings. Circulation is driven solely by destination.
- The construction is multiples of mismatched materials i.e. brick, block, Drivit, clapboards, wood shingles, asphalt shingles, vinyl siding, and vertical metal siding—all colored independently of each other.
- The three buildings are impermeable on all sides but one, oriented solely by street, energy inefficient, and devoid of daylighting and solar strategies.
- The site is exclusive of inviting public space.
- Impermeably paved parking lots and the automobile dominate the site.
- Construction processes were traditional inefficient site built techniques.
- No daylighting strategies are employed.

- Signage both on the buildings and on the street is a smorgasbord.
- No effort is made to harvest rainwater only to control washout.
- Dumpsters are visible from all ordinal points with little or no effort at screening.
- Exterior lighting is adequate for safety, but deteriorated. Lighting ambiance is supplied by mercury vapor.
- Accesses to public transport are casual—walk across the grass.
- Landscape design is nonexistent with barriers to neighbors amounting to overgrown scrub at the site's non-street bordered perimeters.

It is twin, sibling, or cousin to the other 202,999 Commercial Strip Malls.

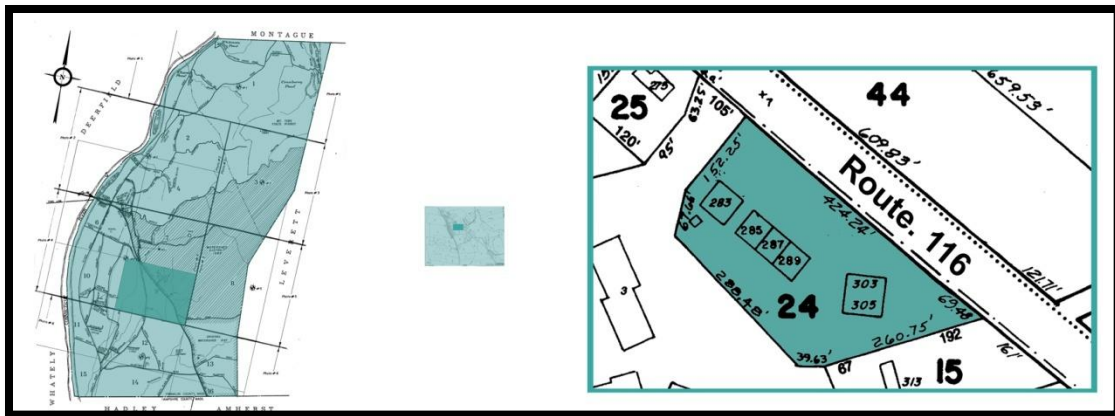
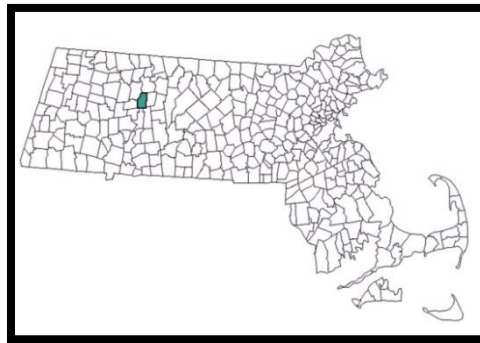

Figure 69: Amherst Road, Rte. 116. Sunderland, Massachusetts
Public Document, Town of Sunderland

Site Coordinates: Lat: 42°27'5.43"N Long: 72°33'45.66"W

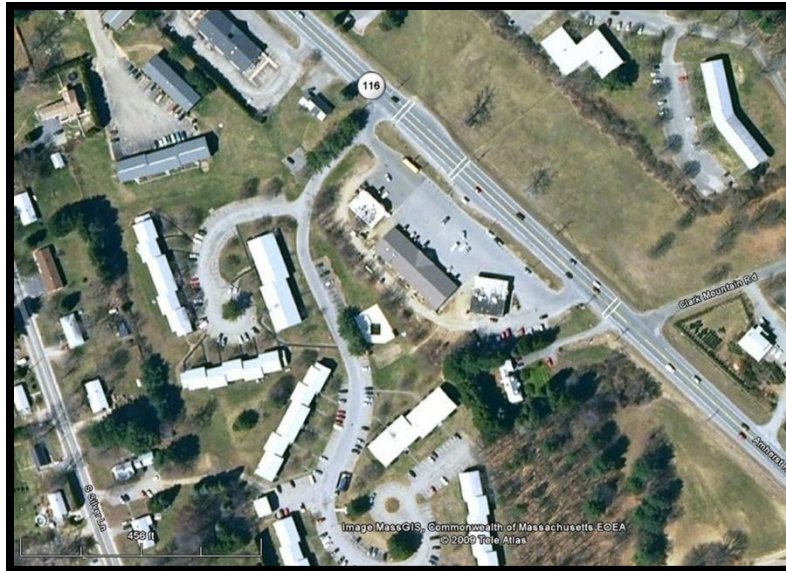

Figure 70: Satellite Image
Image: Courtesy of Google Earth™

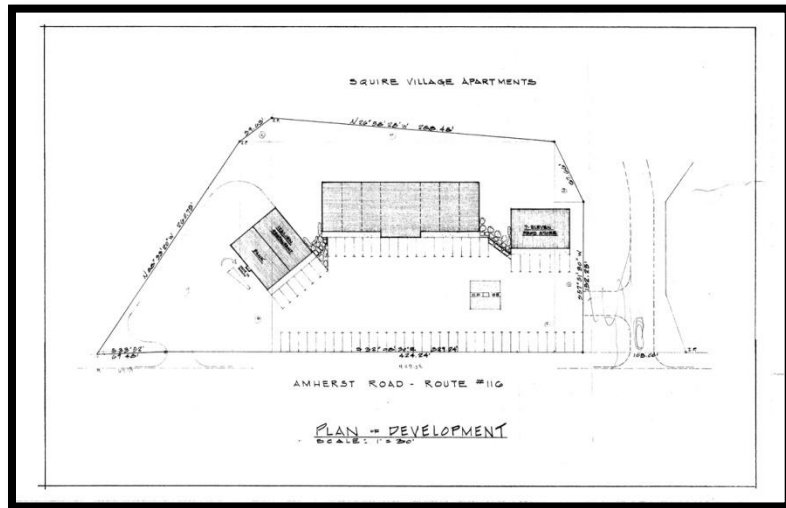

Figure 71: Original Site Plan 1974
Public Document: Town of Sunderland

Residential 1, 2, & 3 Family = Brown

Residential Apartment Complex = Light Tan

Commercial = Blue

Agricultural = Green

Undeveloped = Grey

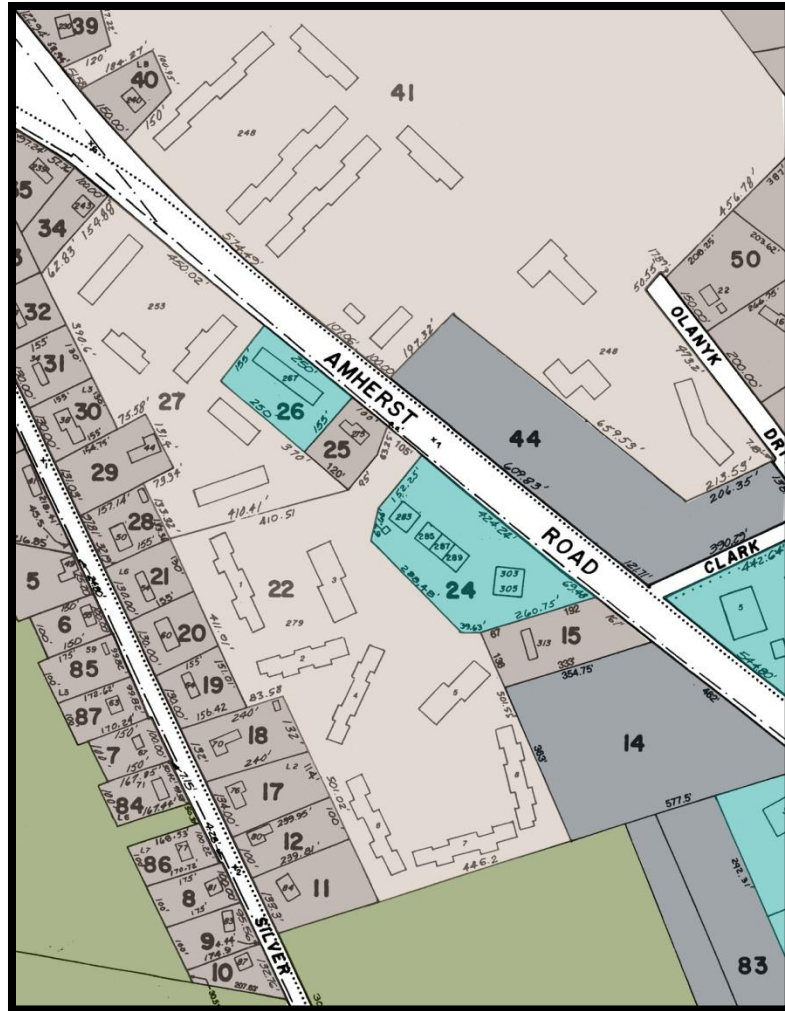

Figure 72: Context Map
Public Document, Town of Sunderland

Area Regulations

After all applicable zoning setbacks, buffer zone requirements, planting requirements, public plaza requirements, and pedestrian pathway requirements (see Appendix A) are met; the restrictions translate into the following metrics of square footages:

- Gross Area of Site: 2.155 acres (93,818 SF).
- Gross Area available for Building and Parking: 1.69 acres (73,616 SF).
- Gross Area available for Building: 1.48 acres (64,463 SF).

Building square footage maximums are capped at 65% of lot size, i.e. 60,983 SF and zoning requires one space for each 200 SF of retail space.

A final regulation that must be taken into the decision making process in the module selection is the ordinance concerning the positioning of buildings on a site:

Major dimensions of any building should be approximately parallel or perpendicular to one (1) or more nearby streets, if within one hundred (100) feet of such street.²⁶

This ordinance when viewed within the context of solar and daylighting strategies seems a trifle draconian; however, the assorted configurations of this design allow solutions to this obstacle and remove the need for a developer who is committed to orientation to incur the expense of research and presentation to a Zoning Board of Appeals in order to obtain a variance from this statute. This can be a costly and unsuccessful effort as it is precedent establishing.

Notes

²⁶ (Sunderland Zoning Bylaws 1999)

The Site Design

The design parameter to maximum building square footage remains paramount throughout the actual site design. The economic reality of this precept will be discussed in Chapter 5, Economics, but there are two other benefits besides increasing leasable space for the developer that should be acknowledged. First, the tax base for the town is increased and second, commercial sprawl is reduced.

The site design went through two principle iterations. The first had the majority of parking shunted to the perimeter with a more pedestrian dominated interior, but frontage requirements, accessible parking requirements, and trash and recycle pickup make pedestrian exclusivity a difficult objective to achieve today on small sites maximized for built square footage.

The idea of areas that exclude the automobile is a long held tenet of site design. The pleasure for the pedestrian of navigating without the concern of traffic in space scaled to an individual rather than a machine is tangible. When that space is defined with the appointments of good architectural pattern, rhythm, and grammar the experience is elevated. However, the regulations (note that they are positive not onerous regulations) that are imposed on these small sites coupled with the fact that the automobile arriving consumer demands maximum ease of access to these retail establishments preclude, at least for this designer, a completely pedestrian environment.

The final design is one creating a streetscape that brings the east tier of buildings in touch with and in reach of the pedestrian circulation on Rte 116. In this area are connecting paths from the mall to the PVRTA Bus Stop, which has been made pedestrian friendly with benches, recycle and trash containers, and shade. The zone offers private

exterior space for the merchants with protected areas for their customers to eat, drink, or relax. Tucked into the south end is a public picnic area. Marquee signage is easily read from the street and while executed with distinctive color does not intrude on the public realm with a visual cacophony. The west side of the site offers the merchants in the second tier similar accommodations of private exterior space for their customers e.g. a place for wine tastings for the liquor store or a place to wait for laundry to finish when at the laundromat.

The zone between the two tiers is the most problematic as it must supply easy access to and from Rte. 116, meet all parking requirements including accessibility, encourage access to each establishment for trash and recycle pickup along with merchandise delivery, meet landscaping regulations, allow for easy maintenance especially snow removal, and get the automobile arriving consumer close to their destination. It is difficult to exclude the automobile with these criteria. To that end, the zone is floored with permeable pavement, which in addition to its environmental qualities provides a much-softened visual texture from cracked and patched asphalt to the expanse. Single loaded parking allows access to the perimeter defining buildings and a maximum amount of landscapes islands were introduced. Bicycle racks are adjacent to all the buildings and the entire site is illuminated for safety and nighttime aesthetics.

A final note on the site design is that all the landscape plantings are dictated by zoning regulations (see Appendix A) and it is a complement to the Town of Sunderland that in 1999 they instituted these regulations (unfortunately not retroactive to earlier projects) that will significantly improve our public landscape.

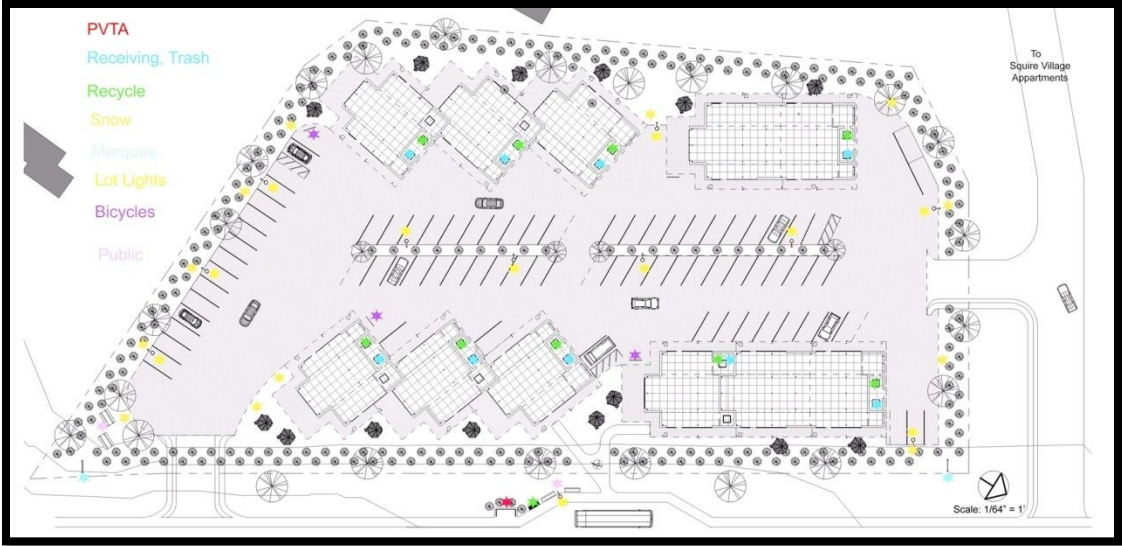

Figure 73: Site Key
 Drawing by Author



Figure 74: Site Plan
 Drawing by Author

CHAPTER 5

ECONOMICS

An important element of a design that incorporates the pragmatic as much as this design does must be Economics. Just as Hornbeck's store —

*The most commercial of commercial buildings—must be conceived, arranged, and designed to sell goods; and if it fails in this requirement it has no reason to exist.*²⁷

So a Commercial Strip Mall must be conceived to be economically feasible to construct or it will have no reason to exist.

It is necessary to introduce a caveat at this point; the numbers that follow are simplifications of complex financial data. The purpose of these numbers is not to establish definitive pricing, but is used to provide a reference point permitting a comparative discussion.

Earlier it was established that when selecting the modular assemblies to use on a site that the parameter “maximize the buildable square footage” was a mandate. The design for this site increases the leasable retail space over the existing by over 38% along with increasing built form amenities of unconditioned space and sheltering canopies (see Figures 75 and 76).

This increase in square footage is naturally reflected in direct proportion to the income production of the site as a leasing rate is based on square footage metrics. It is of paramount importance in commercial real estate that an increase in design costs be mirrored by an increase in income production.

Notes

²⁷ (Hornbeck 1962, 1)

Building	Retail	Unconditioned	Canopy	Perimeter
One.	2500	--	372	--
Two	8240	140	720	--
Three	2400	--	324	--
Totals	13,140 SF	140	1416 SF	--

Figure 75: Existing Site Square Footages
Chart by Author

Building	Retail	Unconditioned	Canopy	Perimeter
Double Long.	3200	180	1410	255
Triple Long.	4800	180	1870	336
Triple Diag. A	4512	360	2680	448
Triple Diag. B	4512	360	2680	448
Totals	16,676 SF	1440 SF	8640 SF	1487 LF

Figure 76: Site Designs Square Footages
Chart by Author

Retail square footage is increased by 4976 SF (38%) accompanied by increases in the built form amenities of unconditioned space and canopies. These additional unconditioned areas are the spaces in the rear of each unit where trash and recycle is stored in large but wheelable containers eliminating the unscreened existing dumpster areas and storage sheds. The additional canopies are shelters over walkways and over merchant's exterior private space.

The importance of increasing the leasable square footage is because in the United States the most common of leases is a Triple Net Lease. In Triple Net leasing, all costs (real estate taxes, building insurance, and maintenance) are paid by the tenant not the developer, so any reduced costs or savings after construction including energy cost savings are enjoyed by the tenant not the developer. It is only through increase in

leasable square footage amounts that a developer is able to increase income from a parcel.

Based on November 2009 National Retail Average of Triple Net leases (\$16.94/SF)²⁸. This design increases the net income of the site by \$84,000. per year. This is a serious assist in marketing this design to a developer as this figure is a dominant decision making number used to make costing choices. Our interest in this number is that it allows entrée into a discussion on the feasibility of introducing a design such as this one, laden with “green components”, because these items are not inexpensive.

The \$84,000. / yr. figure if extended over three, 5, and 15 years will result in simple returns of \$252,879., \$842,934., and \$1, 264,401. respectively. Based on R.S. Means’ data (see Appendix 3) the cost (excluding land costs, architecture fees, development costs, profit, and overhead) of traditional construction of a design with identical square footage, building height, and perimeter on this site in Sunderland is \$1,965,500.

The cost, using simple return, of introducing into that structure just three of the “green components” would not be recovered by the developer for nearly 15 years (see Figure 77). This is a return rate that has been digested in Europe, but here in the U.S. the general expectation is 3 years with 5 an absolute maximum.

Notes

²⁸ (Parady 2009)

	Initial Cost	Extended 3 years	Extended 10yrs.
Green Roofs (10,032 SF):	237,959.	79,319./yr.	23,795./yr.
Triple Glazing with Operable Shades (4000 SF):	712,280.	237,426./yr.	71,280./yr.
SIPS 9 3/8" (34,748 SF):	198,758.	66,252./yr.	19,875./yr.
Total:	1,148,997.		

Figure 77: Green Component Costs
Chart by Author

Are we in trouble with our economics? Well, the square footage increase has headed us in the right direction and the following points of influence must additionally be considered:

- The individual developer’s environmental sensibility and social conscience can always be factor.
- The marketing power of green branding or imaging exists on all levels. It exists for the developer, for the corporate tenant, and for the local tenant. The value of a “green image” through association is a commodity that might be translated into increases in lease rates. Additionally, in an economic time, such as 2010, when there is a glut of unoccupied tenant space in inventories, green and sustainable complexes can be more desirable to a prospective lessee than a traditionally constructed building resulting in a quicker arrival at full occupancy for the developer.
- Cost offsets in the form of State Tax Abatements on property tax or Federal Tax Credits or Incentives can have enormous impact on the fiscal metrics. The State of Nevada currently offers a 35% reduction in real estate taxes for 10 years on all buildings Leed Silver and above.²⁹ Germany is the largest photovoltaic market in the world because of long-term guaranteed feed in tariffs (surplus electricity was bought back at four times the cost of the grids initial billing).³⁰
- Although the prevalence of Triple Net Leases is not likely to disappear and tenant savings from reduced energy costs not being passed back to the developer in any percentage, it is quite possible that with proper metric

Notes

²⁹ (Yudelson 2009, 71)

³⁰ (2010 Global PV Industry Report 2010)

documentation of mechanical system efficiencies, thermal envelope data, and blower door tests establishing air infiltration rates that savings can be concretely demonstrated before the lease is signed and the square foot rate increased so that both lessor and lessee benefit.

- Naturally, increases in energy cost would be a great help, as the impact of any energy savings technologies escalates, in direct proportion to the increases, along with the public awareness to these relevant issues

Daylighting is a subject that, as mentioned previously, might be of some surprise to see in this Chapter on Economics, but it is a subject that is representative of a trend to come. As more and more studies that have been done in the business and academic sectors relating impact of green assemblies or systems on improving occupancy performance, satisfaction, and attendance are replicated in retail the data necessary to justify lease increases will become available.

Up until now, only studies involving daylighting have moved into the retail segment. The findings establish that an environment with good daylighting as opposed to an environment without improves sales by 5%.³¹

Daylight techniques in this design are threefold. Sixteen-foot storefront windows on three sides of all units allow deep penetration of natural light. Clerestories assisted by reflective roofs and ceilings augment the storefront windows and afford even deeper penetration into the interior. Skylights and casement window meet the requirements in the support areas. The systems are illustrated in Figures 78 & 79.

Notes

³¹ (Yudelson 2009, 120 &121)

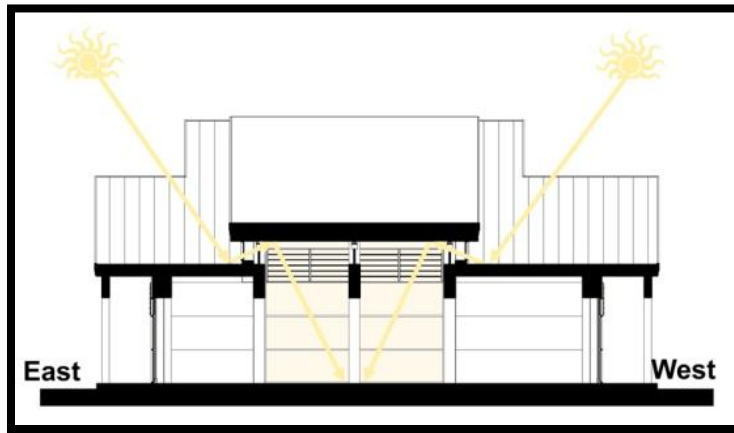

Figure 78: Daylighting View 1
Drawing by Author

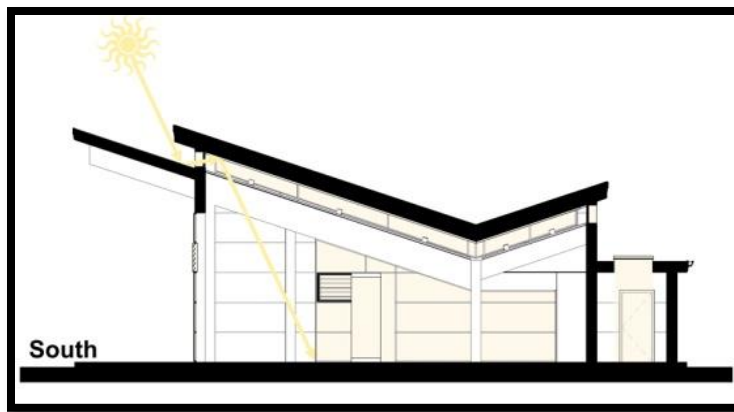

Figure 79: Daylighting View 2
Drawing by Author

Again the question, are we in trouble with our economics? Is this project and others like it economically viable? Will it become more or less viable in the future?

In addition to all of the factors discussed above there is an additional one involved in the financial decision-making as to whether to build or not and if so what to build. It is the fact that the most expensive tenant space of all is unleased space. Therefore, what one builds for retail space in a Commercial Strip Mall, as it will be around for at least 50

years if it follows the example of its predecessors, had best be something that is desirable not just at this moment, but also in the future.

The answer to the question is that now, in 2010, with rising oil prices, a progressive administration, and heightened individual climate awareness this projects and others like it have an excellent chance of becoming part of the built environment.

CHAPTER 6
DENOUEMENT

The previous five chapters have followed the American Commercial Strip Mall from specie origin through species domination. Evolution over the past one hundred plus years for this species has been at a virtual standstill. The introduction of a new design might continue the Darwinian metaphor. The new design is an engineered mutation that has allowed the positive qualities of the species to continue while eliminating the genes that produced the malignant traits in so many of the specie’s organisms. At the same time, the engineering process introduced new genes that produce traits that are beneficial to an individual organism, the collective species, and to the organism’s environment.

These last images offer a reinforcing look at the present underscoring the idea that what exists now is so lacking and a view into the future at a design possibility that developers will come to select as peak oil approaches and climate change accelerates.



Figure 80: Sunderland Site in the Present
Images by Author



Figure 81: View from PVTA toward Strip Mall
Render by Author



Figure 82: Birdseye View of Strip Mall to Southeast
Render by Author

APPENDIX A
CODES AND REGULATIONS

The following are program intents (bold type) in this project accompanied by the associated Building Codes or Zoning Regulations that specifically apply to the Sunderland site as specified by the Massachusetts Building Code and Town of Sunderland Zoning (underlining by Author) and were used as limiting parameters throughout the design process.

1. Building placement should balance solar positioning with street access.

- A. Major dimensions of any building should be approximately parallel or perpendicular to one (1) or more nearby streets, if within one hundred (100) feet of such street.
- B. Minimize obstruction of scenic views from publicly accessible locations.
- C. Scenic views, if any, visible from public ways should be preserved to the degree reasonably consistent with the given type and scale of use.

2. Screening to adjacent properties should be incorporated into design.

- A. Parking lots for eight (8) or more cars shall be screened from any residential use or district, which is abutting or separated from it only by a street. Screening shall be by a four-foot wide planting strip maintained with densely planted shrubs four (4) feet high or greater or by a fence not less than four (4) feet high and shall be landscaped as required by § 125-9F(1).
- B. Parking lots for eight (8) or more cars shall contain or be bordered within five (5) feet by at least one (1) tree per four (4) cars.
- C. For commercial uses, a landscaped buffer strip at least fifteen (15) feet wide, continuous except for approved driveways, shall be established adjacent to any public road to visually separate parking and other uses from the road. The buffer strip shall

be planted with grass, medium height shrubs a minimum of four (4) feet in height planted at least five (5) feet on center] and shade trees a minimum two-inch caliper, planted at least every fifty (50) feet along the road frontage. Artificial trees or plants may not be used to meet these requirements. At all street or driveway intersections, trees or shrubs shall be set back a sufficient distance from such intersections so that they do not present a traffic visibility hazards.

- D. A buffer zone and screening shall be required on any lot in the Commercial District where it adjoins a lot in a residential district. The buffer zone shall be at least thirty (30) feet wide, except for driveways which shall be screened as noted in § 125-7C(6). Adjacent to residential structures in residential districts, the screen shall contain plantings or a wall, fence or berm complemented with plantings. The screen shall be of sufficient density to provide at least seventy-five percent (75%) of continuous opacity at a height of not less than five (5) feet.
- E. The above screening requirement (but not the buffer zone) shall also apply to a lot in any Commercial District for a new commercial or institutional use where it adjoins an existing residence.
- F. Planting strips shall be at least nine (9) feet in width and shall respond to the needs of storing snow, locating light poles and providing safe pedestrian access.

3. Site sign should allow for visibility from both directions on Rt.116, allow for simple change of tenant list.

- A. One (1) additional sign for each firm may be attached to a marquee that is an integral part of the building or attached flat against the wall next to the entranceway, provided that the total area of such a sign does not exceed four (4) square feet in area.

B. For a business complex, a sign with the name of the complex [this portion of the sign cannot exceed twenty (20) square feet in area and five (5) feet in length], beneath which the name of each firm or business in the complex may be incorporated or attached. Such names shall be in letters not to exceed three (3) inches in width and four (4) inches in height and the total length of such name shall not exceed the width of the business complex sign.

C. All such freestanding signs:

[1] Shall be located in accordance with the minimum yard setback requirements

[2] Shall have bottom capping at least thirty (30) inches off the ground. The intervening space may be filled with open latticework or platform decorative trim.

[3] Shall not exceed fifteen (15) feet in height.

[4] Shall not block visibility in either travel direction.

D. In lieu of a freestanding sign, one (1) sign may be placed above a one-story commercial building, provided that the area of said sign does not exceed sixteen (16) square feet in area and it is not more than fifteen (15) feet above the ground.

E. No exterior sign or advertising device shall incorporate motion or be lighted by flashing or blinking lights or utilize a change in light intensity.

F. All illumination of signs or other advertising devices shall be shielded or indirect

4. Community Space in the form of exterior seating and eating locations should be interspersed throughout.

.For projects on one lot with 8,000 square feet or more of enclosed gross floor area, pedestrian plazas shall be created at a minimum rate of 5% of the gross floor area and

contain at least two of the following amenities: public art; a fountain; tables and chairs at a rate of one table per 400 square feet of plaza and one chair per 100 feet of plaza; two linear feet of bench or seating wall per 200 square feet of plaza; bike racks or lockers; or any similar structure or amenities approved by the Planning Board.

5. Public Bus Stop in front of site should be included with overall circulation.

Whenever feasible, pedestrian walkways shall be integrated into the design of the site and parking lot. Where a walkway crosses a vehicular path, the walkway shall be defined through the use of different paving materials that have a different texture or color. A sidewalk shall be included within the front yard of commercial uses to facilitate access from the street. Sidewalks shall be set back at least nine feet from the edge of the road, except that for short distances this setback may be reduced in order to connect a new sidewalk to an existing sidewalk. Sidewalks should be connected between adjacent properties to the maximum extent possible. Maximize pedestrian and vehicular safety and convenience within the site and egressing from it.

6. Exterior Lighting should respond to efficiency, safety, and enhancement of site at night.

Any outdoor lighting fixture newly installed or replaced shall be shielded so that it does not produce a strong, direct light beyond the property boundaries and the light emitted shall be white in color. No light standard shall be taller than sixteen (16) feet. Lighting fixtures shall be consistent with the historic character of the district. No uplighting of signs or buildings shall be permitted.

7. Buildings should make statement of “successful mercantile establishments” but not appear to “upscale”.

The appearance of primary wall and roof materials should match that of materials commonly found on existing buildings within the town. Domestic scale should be maintained, in the case of large structures, through massing devices such as breaks in wall and roof planes and through design of architectural features. The building should not be made, in effect, a sign through painting with bold patterns, checks or other graphics devices or use of unconventional building form. There should be some element of consistency with any buildings on abutting premises facing the same street, such as consistency in eave height, wall materials, roof pitch, or window proportions.

8. The gross square footage of the building should be maximized for the site.

Principal Uses	VR	RR	C-1	C-2
Retail store(s) - Building less than or 5,000 square feet	N	N	Y	Y
<u>Retail store(s) - Building between</u> <u>5,000 and 10,000 square feet</u>	N	N	SP	SP
Retail store(s) - Building greater than 10,000 square feet	N	N	N	N

9. Envelope thermal efficiency and air sealing should be paramount.

TABLE 1303.2 CLIMATE ZONE THERMAL DESIGN CRITERIA

Climate Zone #	12a	13a	14a
Heating Degrees (°F) Winter	9	7	-1
Cooling Degrees (°F) Dry Bulb Summer	86	87	86
Cooling Degrees (°F) Wet Bulb Summer	74	74	73
Heating Degree Days Base 65	5884	5641	6894
Heating Degree Days Base 50	2553	2399	3448
Cooling Degree Days Base 65	606	678	507
Cooling Degree Days Base 50	2743	2897	2525
Cooling Degree Hours Base 80	939	1299	409

TABLE 1304.2.11 BUILDING ENVELOPE REQUIREMENTS

Climate Zone 14a

Glazing Area Over 25% but not greater than 40% of Above Grade Wall Area

Above-Grade Wall:	Continuous Insulation (or average insulation value)*	Metal Framing (c.i. = continuous insulation)	Wood Framing
Framed or Masonry < 35 psf.	R-7	R-13 + R-3 c.i.	R-11
Masonry ≥ 35 psf.	R-5	R-11 + R-3 c.i.	R-11

Window Assemblies:	SHGC (maximum)	U-Value (maximum)
PF < 0.25	0.4	0.5
0.25 ≤ PF < 0.50	0.5	0.5
PF ≥ 0.50	0.6	0.5
Skylights - U-Value (maximum)	NA	0.8

Roof Assemblies. (either/or)	Insulation Between Framing	Continuous Insulation
All-Wood Joist/Truss	R-30	R-23
Non-wood Joist/Truss	R-30	R-24
Concrete Slab or Deck	NA	R-23
Metal Purlin with Thermal Break	NA	R-24
Metal Purlin w/o Thermal Break	NA	R-24

Floor Assemblies. (either/or)	Insulation Between Framing	Continuous Insulation
All-Wood Joist/Truss	R-25	R-18
Non-wood Joist/Truss	R-25	R-19
Concrete Slab or Deck	NA	R-19
Slab, Perimeter, and Below-Grade Wall	R-5	

* For masonry walls, average R-value shall be calculated based on the assumption of isothermal planes, using methodology in 2005 ASHRAE Fundamentals Handbook, Chapter 25.

TABLE 1304.2.12 BUILDING ENVELOPE REQUIREMENTS
Climate Zone 14a
Glazing Area Over 40% but not greater than 50% of Above Grade Wall Area

Above-Grade Wall:	Continuous Insulation (or average insulation value)*	Metal Framing (c.i. = continuous insulation)	Wood Framing
Framed or Masonry < 35 psf.	R-7	R-13 + R-3 c.i.	R-11
Masonry ≥ 35 psf.	R-5	R-11 + R-3 c.i.	R-11

Window Assemblies:	SHGC (maximum)	U-Value (maximum)	
PF < 0.25	0.4	0.4	
0.25 ≤ PF < 0.50	0.5	0.4	
PF ≥ 0.50	0.6	0.4	
Skylights - U-Value (maximum)	NA	0.8	

Roof Assemblies. (either/or)	Insulation Between Framing	Continuous Insulation	
All-Wood Joist/Truss	R-30	R-23	
Non-wood Joist/Truss	R-30	R-24	
Concrete Slab or Deck	NA	R-23	
Metal Purlin with Thermal Break	R-38	R-24	
Metal Purlin w/o Thermal Break	R-38	R-24	

Floor Assemblies. (either/or)	Insulation Between Framing	Continuous Insulation	
All-Wood Joist/Truss	R-25	R-18	
Non-wood Joist/Truss	R-25	R-19	
Concrete Slab or Deck	NA	R-19	
Slab, Perimeter, and Below-Grade Wall	R-5		

* For masonry walls, average R-value shall be calculated based on the assumption of isothermal planes, using methodology in 2005 ASHRAE Fundamentals Handbook, Chapter 25.

TABLE 1304.2.12 BUILDING ENVELOPE REQUIREMENTS
Climate Zone 14a
Glazing Area Over 40% but not greater than 50% of Above Grade Wall Area

Above-Grade Wall:	Continuous Insulation (or average insulation value)*	Metal Framing (c.i. = continuous insulation)	Wood Framing
Framed or Masonry < 35 psf.	R-7	R-13 + R-3 c.i.	R-11
Masonry ≥ 35 psf.	R-5	R-11 + R-3 c.i.	R-11

Window Assemblies:	SHGC (maximum)	U-Value (maximum)	
PF < 0.25	0.4	0.4	
0.25 ≤ PF < 0.50	0.5	0.4	
PF ≥ 0.50	0.6	0.4	
Skylights - U-Value (maximum)	NA	0.8	

Roof Assemblies. (either/or)	Insulation Between Framing	Continuous Insulation	
All-Wood Joist/Truss	R-30	R-23	
Non-wood Joist/Truss	R-30	R-24	
Concrete Slab or Deck	NA	R-23	
Metal Purlin with Thermal Break	R-38	R-24	
Metal Purlin w/o Thermal Break	R-38	R-24	

Floor Assemblies. (either/or)	Insulation Between Framing	Continuous Insulation	
All-Wood Joist/Truss	R-25	R-18	
Non-wood Joist/Truss	R-25	R-19	
Concrete Slab or Deck	NA	R-19	
Slab, Perimeter, and Below-Grade Wall	R-5		

* For masonry walls, average R-value shall be calculated based on the assumption of isothermal planes, using methodology in 2005 ASHRAE Fundamentals Handbook, Chapter 25.

TABLE 1304.2.9 BUILDING ENVELOPE REQUIREMENTS
Climate Zone 14a
Glazing Area 10% or less of Above Grade Wall Area

Above-Grade Wall:	Continuous Insulation (or average insulation value)*	Metal Framing (c.i. = continuous insulation)	Wood Framing
Framed or Masonry < 35 psf.	R-7	R-11 + R-3 c.i.	R-11
Masonry >= 35 psf.	R-5	R-11 + R-3 c.i.	R-11

Window Assemblies:	SHGC (maximum)	U-Value (maximum)
PF < 0.25	Any	0.7
0.25 <= PF < 0.50	Any	0.7
PF >= 0.50	Any	0.7
Skylights - U-Value (maximum)	NA	0.8

Roof Assemblies. (either/or)	Insulation Between Framing	Continuous Insulation
All-Wood Joist/Truss	R-19	R-17
Non-wood Joist/Truss	R-25	R-18
Concrete Slab or Deck	NA	R-17
Metal Purlin with Thermal Break	R-30	R-18
Metal Purlin w/o Thermal Break	NA	R-18

Floor Assemblies. (either/or)	Insulation Between Framing	Continuous Insulation
All-Wood Joist/Truss	R-25	R-18
Non-wood Joist/Truss	R-25	R-19
Concrete Slab or Deck	NA	R-19

Slab, Perimeter, and Below-Grade Wall R-5

* For masonry walls, average R-value shall be calculated based on the assumption of isothermal planes, using methodology in 2005 ASHRAE Fundamentals Handbook, Chapter 25.

10. Moisture Control. The design of buildings for energy conservation shall not create conditions of accelerated deterioration from moisture condensation.

A vapor retarder shall be installed on the winter warm side of walls, ceilings and floors enclosing a conditioned space. Batt/blanket insulation with a vapor retarder attached shall be attached to the winter warm sides or faces of wall studs, sole plates, top plates, lintels and headers at intervals of eight inches on center to prevent convection loops through the insulation. Where batt/blanket insulation is of a "friction fit" design and a sheet vapor retarder is employed, the vapor retarder shall be affixed to the interior face of the wall studs, sole plates, top plates, lintels and headers winter warm side in accordance with the vapor retarder manufacturer's recommendations. All other envelope building materials and finishes installed towards the cooler, exterior side of the wall shall have water vapor permeance at least ten times greater than the interior vapor retarder material.

Exceptions:

1. Materials to the exterior of a ventilated rainscreen cavity may have any permeability.
2. Envelope systems that maintain the temperature of potential condensing surfaces (typically the interface of exterior sheathing with cavity insulation) above the dewpoint temperature of the interior air.

11. Slabs on Grade.

The minimum thermal resistance (R-value) of the insulation around the perimeter of the slab floor on grade shall be R-5. The insulation shall be placed on the outside of the foundation or on the inside of a foundation wall. Insulation on the outside of the foundation wall shall extend downward from the top of the slab for a minimum of 48 in. Insulation on the inside of the foundation wall shall extend downward to at least the bottom of the slab and then horizontally for a minimum total distance of 48 in. In addition, the entire area of the slab on grade shall be insulated with a minimum of R-5 rigid insulation in the following buildings. Buildings of use group E, including daycare; buildings of use groups R-1, R-2, I-1 and I-2, and; college and university buildings of B and A use groups.

Exception. For a monolithic slab on grade floor, the insulation shall extend from the top of the slab on grade to the bottom of the footing. Continuous under-slab insulation shall be provided per 780 CMR 1304.2.8.

12. Daylighting opportunities should be fully investigated.

Skylights located in the building envelope shall be limited to 3% of the gross roof assembly area and shall have a maximum thermal transmittance (U-value) of the skylight assembly as specified in Tables 1304.2.1-12.

13. Lighting Systems should be CFL, T-5, or LED.

780 CMR 1308.0 LIGHTING SYSTEMS

1308.1 General. The lighting criteria in 780 CMR 1308.0 shall apply to lighting for the following:

1. Interior spaces of buildings;
2. Exterior building features, including façades, illuminated roofs, architectural features, entrances, exits, loading docks, and illuminated canopies; and,
3. exterior building grounds lighting provided through the *building's* electrical service.

Exceptions:

1. emergency lighting that is automatically off during normal *building* operation and is powered by battery, generator, or other alternate power source; and,
2. lighting within living units of residential buildings;
3. lighting that is specifically designated as required by a health or life safety statute, ordinance, or regulation;
4. decorative gas lighting systems.

1308.2 Lighting Control.

1308.2.1 Automatic Lighting Shutoff. Interior lighting in buildings larger than 5000 ft² shall be controlled with an automatic control device to shut off building lighting in all spaces. This *automatic control device* shall function on either:

1. a scheduled basis using a time of day operated control device that turns lighting off at specific programmed times. An independent program schedule shall be provided for areas of no more than 25,000 ft² but not more than one floor; or
2. an occupant sensor that shall turn lighting off within 30 minutes of an occupant leaving a space; or

3. an unscheduled basis by occupant intervention.

Exceptions:

1. Lighting intended for 24-hour operation shall not require an Automatic Control Device.

2. Automatic Control Devices are not required in the following spaces: corridors, hallways, stairways and lobbies, which are part of a required means of egress; restrooms; mechanical rooms, and; electrical rooms. If automatic control devices are used in the spaces listed, they shall not reduce illumination below the levels prescribed in 780 CMR 1024.0 (Means of Egress Lighting.)

1308.2.2 Space Control. Each space enclosed by ceiling-height partitions shall have at least one *control device* to independently *control* the *general lighting* within the space.

Each *control device* shall be activated either manually by an occupant or automatically by sensing an occupant.

Each control device shall.

1. *control* a maximum of 2,500 ft² area for a space 10,000 ft² or less, and a maximum of 10,000 ft² area for a space greater than 10,000 ft²,
2. be capable of overriding the shutoff *control* required in 780 CMR 1308.2.1 for no more than two hours, and
3. be readily accessible and located so the occupant can see the controlled lighting.

Exceptions:

1. Remote location shall be permitted for reasons of safety or security when the remote control device has an indicator pilot light as part of or next to the control device

and it shall be clearly labeled to identify the controlled lighting.

2. Means of egress lighting, which provides the minimum illumination, identified in 780 CMR 1308.2.1 Exception 2. shall be controlled in accordance with 780 CMR 1024.0.

1308.2.5 Exterior Lighting Control. Lighting for all exterior applications not exempted in 780 CMR 1308.1 or 1308.7 shall be controlled by a photosensor or astronomical time switch that is capable of automatically turning off the exterior lighting when sufficient daylight is available or the lighting is not required.

Exception. Lighting for covered vehicle entrances or exits from buildings or parking structures where required for safety, security or eye adaptation, enclosed refrigerator and freezer cases.

1308.6.2.1 Building Area Method of Calculating Interior Lighting Power

Allowance. The Building Area Method shall be used only in the following cases:

- (a) projects involving the entire building, or
- (b) projects involving a single, independent, and separate occupancy in a multi-occupancy building

Use the following steps to determine the interior lighting power allowance by the Building Area Method:

1. Determine the appropriate building type from Table 1308.6.2.1 and the allowed lighting power density (watts/unit area) from the building area method column. For building types not listed, selection of a reasonably equivalent type shall be permitted.
2. Determine the gross lighted floor area (square feet) of the *building*.

3. The interior lighting power allowance is the product of the lighted floor area of the building times the lighting power density.

TABLE 1308.6.2.1 LIGHTING POWER DENSITIES USING THE BUILDING AREA METHOD

Lighting Power Density	
Building Area Type ^a	(W/ft ²)
Automotive Facility	0.9
Convention Centre	1.2
Courthouse	1.2
Dining: Bar Lounge/Bar	1.3
Dining: Cafeteria/Fast Food	1.4
Dining: Family	1.6
Dormitory	1.0
Exercise Center	1.0
Gymnasium	1.1
Healthcare-clinic	1.0
Hospital	1.2
Hotel	1.0
Library	1.3
Manufacturing Facility	1.3
Motel	1.0
Motion Picture Theatre	1.2
Multi-family	0.7
Museum	1.1
Office	1.0
Parking Garage	0.3
Penitentiary	1.0
Performing Arts Theatre	1.6
Police/Fire Station	1.0
Post Office	1.1
Religious Buildings	1.3
Retail ^b	1.5
School/University	1.2
Sports Arena	1.1
Town Hall	1.1
Transportation	1.0
Warehouse	0.8
Workshop	1.4

For SI: 1 foot = 304.8mm, 1 watt per square foot = W/0.0929 m²

a. In cases where both a general building area type and a more specific building area type are listed, the more specific building area type shall apply.

b. Where lighting equipment is specified to be installed to highlight specific merchandise in addition to lighting equipment specified for general lighting and is switched or dimmed on circuits different from the circuits for general lighting, the smaller of the actual wattage of the lighting equipment installed specifically for merchandise, or 1.6W/ft² times the area of the specific display but not to exceed 50% of the floor area, or 3.9 W/ft² times the actual case or shelf area for displaying and selling jewelry, china or silver, shall be added to the interior lighting power determined in accordance with this line item.

14. Energy saving options of lightning (LED and CFL), heating (Condensing Boilers coupled with Energy Recovering Ventilation. cooling (passive ventilation coupled with correctly sized air conditioning units), and plumbing (dual flush toilets and low flow fixtures) should be employed.

Building Designs by Systems Analysis 1309.1 General. 780CMR 1309.0 establishes design criteria in terms of total energy use by a building including all of its systems. A building designed in accordance with 780CMR 1309.0 will be deemed as complying with 780CMR13.00 if the annual energy consumption is not greater than if the building were designed with enclosure elements and energy consuming systems in compliance with 780CMR 1304.0 through 1308.0.

1309.2 Analysis Procedure. The analysis of the annual energy usage of the standard and the proposed alternative building and system design shall meet the following criteria:

1. Energy Analysis. The calculation procedure used to simulate the operation of the building and its service systems through a full year operating period shall be of sufficient detail to permit the evaluation of the effect of system design, climatic factors, operational characteristics, and mechanical equipment on annual energy usage. The calculation procedure shall be based upon 8760 hours of operation of the building and its service systems and shall utilize techniques recommended in the ASHRAE Handbook, 1997 Fundamentals Volume.
2. Climatic Data. Coincident hourly data for temperatures, solar radiation, wind and Humidity of typical days in the year representing seasonal variation, in accordance with Tables 1303.1 and 1303.2.
3. Energy Sources. Identical energy sources must serve the same purpose in both the standard and the proposed alternative design. If the proposed alternative design results in an increase in consumption of one energy source and a decrease in another energy source, each energy source shall be converted to equivalent Btu units for purposes of comparing the total energy used. Consumption of electricity shall be converted at the rate of 10,000

Btu/kWh for the purpose of this comparison.

4. Nondepletable Energy Sources. Energy collected on site from nondepletable sources shall be omitted from the comparison of total energy used. Energy collected off site from nondepletable sources shall be included in the comparison of total energy used.

5. Building Operation. Building operation shall be simulated for a full calendar year.

Operating schedules shall include hourly profiles for daily operation and shall account for variations between weekdays, weekends, holidays, and any seasonal operation. Schedules shall model the time dependent variations of occupancy, illumination, receptacle loads, thermostat settings, mechanical ventilation, HVAC equipment availability, service hot water usage, and any process loads

Exception. Operating schedules shall be permitted to differ between the proposed design and the standard design to allow simulation of the impact of any automatic control provided in the proposed design beyond the minimum requirements in 780 CMR 1304.0 through 1309.0.

6. Simulated Loads. The following systems and loads shall be modeled in determining total building performance. heating systems; cooling systems; fan systems; lighting power; receptacle loads; and process loads that exceed 1.0 watts per square foot of floor area of the room or space in which the process loads are located.

Exception. Systems required for emergency power only.

7. Service Water Heating Systems. Service water heating systems that are other than shall be permitted to be omitted from the energy analysis provided all requirements of 780 CMR 1306 have been met.

APPENDIX B

COSTING SOFTWARE

The costing software used to establish dollar figures presented in Chapter 5, Economics was provided by R.S.Means CostWorks. A reiteration of the caveat presented in Chapter 5 is that the figures used are simplifications of complex financial data. The purpose of these numbers is not to establish definitive pricing, but rather to provide a reference point permitting a comparative discussion.

The initial step in the process was to use the software's capabilities of yielding a cost per square foot of building footprint based on R.S.Means proprietary material and cost assumptions that are installed in the program. The only variables that the user is able to insert are:

- Building Type
- Location
- Number of Stories
- Story Height
- Floor Area
- Perimeter
- Basement or Slab

The software then generates a list (see Figure 82) of the assemblies used in “constructing” the building, their individual costs, and the percent of the overall cost they represent. Finally, a cost per square foot of footprint estimate is given for the specific location stipulated at either open shop or union labor rates to which, if desired profit, overhead, architectural fees , and users fees can be added (they were entered as 0 in this design).

It is also possible to back out the number of square feet of a product, for instance glazing, that will be in the project by dividing the total cost of the list item by the square footage cost, available from the individual assembly costing part of the program.

Square Foot Cost Estimate Report

Estimate Name: **Site**
 LCF Designs
 Amherst Road
 Sunderland
 Massachusetts
 01375

Building Type: **Store, Convenience with Metal Sandwich Panel / Steel Frame**
 Location: **SPRINGFIELD, MA**
 Stories Count (L.F.): **1.00**
 Stories Height: **17.00**
 Floor Area (S.F.): **18,116.00**
 Labor Type: **Open Shop**
 Statement Included: **No**
 Data Release: **Year 2010 Quarter 1**
 Cost Per Square Foot: **\$108.47**
 Total Building Cost: **\$1,965,000**



Costs are derived from a building model with basic components. Scope differences and market conditions can cause costs to vary significantly. Parameters are not within the ranges recommended by RSMeans.

		% of Total	Cost Per SF	Cost
A Substructure		11.3%	12.20	\$21,000
A1010	Standard Foundations		2.04	\$37,000
	Strip footing, concrete, unreinforced, load 2.8 KLF, soil bearing capacity 3 KSF, 8" deep x 16" wide			
	spread footings, 3000 PSI concrete, load 25K, soil bearing capacity 3 KSF, 3'-0" square x 12" deep			
	spread footings, 3000 PSI concrete, load 50K, soil bearing capacity 3 KSF, 4'-0" square x 12" deep			
A1030	Slab on Grade		4.55	\$82,500
	Slab on grade, 4" thick, non industrial, reinforced			
A2010	Basement Excavation		0.52	\$9,500
	Excavate and fill, 4000 SF, 4' deep, sand, gravel, or common earth; on site storage			
A2020	Basement Walls		5.08	\$92,000
	Foundation wall, CIP, 4" wall height, direct chute, .095 CY/LF, 4.8 PLF, 8" thick			
B Shell		56.7%	55.03	\$997,000
B1010	Floor Construction		6.66	\$12,000
	Flooring, gypsum board, fire rated, 1 layer, 1/2" thick, 8" steel column, 2 hour rating, 8 PLF			
B1020	Roof Construction		8.09	\$146,500
	Floor, steel joists, beams, 1.5" x 22 ga metal deck, on columns, 30'x30' bay, 28" deep, 40 PSF superimposed load, 62			
	Floor, steel joists, beams, 1.5" x 22 ga metal deck, on columns, 30'x30' bay, 28" deep, 40 PSF superimposed load, 62			
B2010	Exterior Walls		24.95	\$452,000
	Metal siding, steel, sandwich panels, factory fabricated, 2" polystyrene, steel core, 26 ga, colored 2 sides			
	Metal siding support, 18" building height, 20 PSF wind load, 30" column spacing			
B2020	Exterior Windows		12.01	\$217,500
	Aluminum flush tube frame, thermo-break frame, 2.25" x 4.5", 5/16" opening, no intermediate horizontals			
	Glazing panel, plate glass, 1/4" thick, clear			
B2030	Exterior Doors		2.84	\$51,500
	Door, aluminum & glass, without transom, wide stile, double door, hardware, 6'-0" x 7'-0" opening			
	Door, birch, solid core, double door, hinged, 3'-0" x 7'-0" opening			
B3010	Roof Coverings		6.49	\$117,500
	Roofing, asphalt roof coat, gravel, base sheet, 3 plies 15# asphalt felt, mopped			
	Insulation, rigid, roof deck, composite with 2" EPS, 1" perlite			
	Roof edges, aluminum, duranodic, .050" thick, 6" face			
	Gutters, box, aluminum, .027" thick, 5", e-temaled finish			
	Downspout, aluminum, rectangular, 3" x 4", e-temaled, .024" thick			
C Interiors		10.4%	11.23	\$203,500
C1010	Partitions		0.66	\$12,000
	Wood partition, 5/8" fire rated gypsum board face, none base 2 x 4 @ 16" OC framing, same opposite face, 0 insul			
C1020	Interior Doors		0.80	\$14,500
	Door, single leaf, wood frame, 3'-0" x 7'-0" x 1-3/8", birch, solid core			
	Door, double leaf, kd steel frame, hollow metal, commercial quality, B label, 2 - 3'-0" x 7'-0" x 1-3/8"			
C3010	Wall Finishes		3.59	\$65,000
	2 coats paint on masonry with block filler			
	Painting, interior on plaster and drywall, brushwork, primer & 2 coats			
C3020	Floor Finishes		2.90	\$52,500
	Vinyl, composition tile, maximum			
C3030	Ceiling Finishes		3.28	\$59,000
	Acoustic ceilings, 5/8" fiberglass board, 24" x 48" tile, tee grid, suspended support			
D Services		27.3%	30.60	\$543,000
D2010	Plumbing Fixtures		2.18	\$39,500
	Water closet, vitreous china, tank type, 2 piece close coupled			
	Lavatory white, vanity top, PE on CL, 18" round			
D2020	Domestic Water Distribution		1.21	\$22,000
	Gas fired water heater, residential, 100+ F rise, 30 gal tank, 32 GPH			
D3050	Terminal & Package Units		7.18	\$130,000
	Rooftop, single zone, air conditioner, food supermarkets, 5,000 SF, 14.17 ton			
D4010	Sprinklers		3.81	\$69,000
	Wet pipe sprinkler systems, steel, light hazard, 1 floor, 5000 SF			
D5010	Electrical Service/Distribution		2.48	\$45,000
	Service installation, includes breakers, metering, 20' conduit & wire, 3 phase, 4 wire, 120/208 V, 200 A			
	Feeder installation 600 V, including RGS conduit and XHHW wire, 200 A			
	Switchgear installation, incl switchboard, panels & circuit breaker, 400 A			
D5020	Lighting and Branch Wiring		9.00	\$163,000
	Receptacles incl plate, box, conduit, wire, 2.5 per 1000 SF, 3 watts per SF			
	Miscellaneous power, 1 watt			
	Central air conditioning power, 4 watts			
	Fluorescent fixtures recess mounted in ceiling, 3 watt per SF, 60 FC, 15 fixtures @40 watt per 1000 SF			
D5030	Communications and Security		3.78	\$68,500
	Communication and alarm systems, fire detection, non-addressable, 25 detectors, includes outlets, boxes, conduit a			
D5090	Other Electrical Systems		0.36	\$6,500
	Generator sets, w/battery, charger, muffler and transfer switch, gas/gasoline operated, 3 phase, 4 wire, 277/480 V, 7			
E Equipment & Furnishings		0.0%	0.00	\$0
E1090	Other Equipment		0.00	\$0
F Special Construction		0.0%	0.00	\$0
G Building Sitework		0.0%	0.00	\$0
Sub Total		100%	\$108.47	\$1,965,000
Contractor's Overhead & Profit		0.0%	\$0.00	\$0
Architectural Fees		0.0%	\$0.00	\$0
User Fees		0.0%	\$0.00	\$0
Total Building Cost		100%	\$108.47	\$1,965,000

Figure 83: Total Construction Costs/SF of Sunderland Strip Mall

The second part of this exercise was to use the software's ability to retrieve detailed square foot costs of specific assemblies (materials and labor) based on the 2004 Master Format, using labor rates (open or union shop) in your specific location. It is then possible to take the total square footage of these assemblies extracted for the Total Square Footage Cost Estimate, and multiply that figure by the difference in the cost between traditional assembly and "green assembly". Thus, the cost of that particular "green assembly" for the entire design is arrived at.

The three particular "green assemblies" selected from the design were Green Roofs, Triple Glazing, and SIPS. The pricing for these assemblies (see Figures 83-85) coupled with the Total Square Footage Cost Estimate provide the numbers necessary to produce the discussion offered in Chapter 5, Economics.

CostWorks
RSMeans

Welcome Carl Fioechi | Quick Tour | Help | User Groups | Sign Off

Home | Construction Estimate | Square Foot Estimator | Cost Breaks | My Account | Company Admin

New Estimate | Estimate View | Report Selection

Line Number: [] | Estimate Action: [] | Search Type: []

Line Number	Description	Unit	Extended Total	Extended Total O&P	Labor Type	Notes
073363100010	Green roof systems	S.F.	\$ 0.00	\$ 0.00	Open Shop	
073363100150	Green roof systems, hoist and spread soil mixture 6 in. depth up to five stories tall roof	S.F.	\$ 1.47	\$ 2.02	Open Shop	
073363100400	Green roof systems, green roof edging treated lumber, 4" x4", excludes hoisting	L.F.	\$ 3.24	\$ 4.25	Open Shop	
073363100600	Green roof systems, planting sedum, light soil, potted, 2 per SF, 2-1/4" diameter, includes planting only	S.F.	\$ 5.29	\$ 6.18	Open Shop	
073363100630	Green roof systems, planting sedum mat, per SF, includes planting only, 4000 SF minimum	S.F.	\$ 5.90	\$ 6.59	Open Shop	
073363100640	Green roof systems, installation sedum mat system (no soil required), per SF, 4000 SF minimum	S.F.	\$ 8.68	\$ 9.05	Open Shop	
			\$ 23.78	\$ 28.09		

LCF Designs,
Amherst Road,
Sunderland,
Massachusetts , 01375
Year 2010 Quarter 1

Unit Detail Report

Green Roof

Cost Estimate Report
CostWorks
RSMeans

Prepared By:
Carl Fioechi
LCF Designs

Date: 11-Apr-10

Line Number	Description	Quantity	Unit	Total Incl. O&P	Ext. Total Incl. O&P
Division 07 Thermal And Moisture Protection					
073363100010	Green roof systems	1		\$0.00	\$0.00
073363100150	Green roof systems, hoist and spread soil mixture 6 inch depth up to five stories tall roof	1	S.F.	\$2.02	\$2.02
073363100400	Green roof systems, green roof edging treated lumber, 4" x4", excludes hoisting	1	L.F.	\$4.25	\$4.25
073363100600	Green roof systems, planting sedum, light soil, potted, 2 per SF, 2-1/4" diameter, includes planting only	1	S.F.	\$6.18	\$6.18
073363100630	Green roof systems, planting sedum mat, per SF, includes planting only, 4000 SF minimum	1	S.F.	\$6.59	\$6.59
073363100640	Green roof systems, installation sedum mat system (no soil required), per SF, 4000 SF minimum	1	S.F.	\$9.05	\$9.05
Division 07 Thermal And Moisture Protection Subtotal					\$28.09

Figure 84: Extensive Green Roof Pricing

CostWorks® Welcome Carl Fiochi | Quick Tour | Help | User Group | Sign Off

Home Construction Estimate Square Foot Estimator Cost Books My Account Company Admin

New Estimate Estimate View Report Selection

Line Number: Description: Keywords Search Reset Search Tips

Remove Insert Save Estimate Action Select from List View: Basic

Quantity	Line Number	Description	Unit	Extended Total	Extended Total O&P	Labor Type	Notes
1	084413100010	GLAZED CURTAIN WALLS, aluminum, stock, including		\$ 0.00	\$ 0.00	Open Shop	
1	084413100050	Curtain Wall, aluminum, stock, single glazed, incl. glaz	S.F.	\$ 54.31	\$ 64.31	Open Shop	
1	084413100200	Curtain Wall, aluminum, stock, incl. glazing, maximum	S.F.	\$ 178.07	\$ 200.78	Open Shop	
				\$ 232.38	\$ 265.09		

LCF Designs,
Amherst Road,
Sunderland,
Massachusetts, 01375
Year 2010 Quarter 1

Unit Detail Report

Cost Estimate Report
CostWorks®
RSMeans

Prepared By:
Carl Fiochi
LCF Designs

Date: 11-Apr-10

Triple Glaze

Line Number	Description	Quantity	Unit	Total Incl. O&P	Ext. Total Incl. O&P
084413100010	GLAZED CURTAIN WALLS, aluminum, stock, including glazing	1		\$0.00	\$0.00
084413100050	Curtain Wall, aluminum, stock, single glazed, incl. glazing, average	1	S.F.	\$64.31	\$64.31
084413100200	Curtain Wall, aluminum, stock, incl. glazing, maximum	1	S.F.	\$200.78	\$200.78
Division #8 Openings Subtotal					\$265.09

Figure 85: Triple Glazed Window Pricing

CostWorks® Welcome Carl Fiochi | Quick Tour | Help | User Group | Sign Off

Home Construction Estimate Square Foot Estimator Cost Books My Account Company Admin

New Estimate Estimate View Report Selection

Line Number: Description: Keywords Search Reset Search Tips

Remove Insert Save Estimate Action Select from List View: Basic

Quantity	Line Number	Description	Unit	Extended Total	Extended Total O&P	Labor Type
1	061210000000	Structural Insulated Panels		\$ 0.00	\$ 0.00	Open Shop
1	061210100130	Structural insulated panels, 7/16" OSB both faces, EPS	S.F.	\$ 5.72	\$ 6.95	Open Shop
				\$ 5.72	\$ 6.95	

LCF Designs,
Amherst Road,
Sunderland,
Massachusetts, 01375
Year 2010 Quarter 1

Unit Detail Report

Cost Estimate Report
CostWorks®
RSMeans

Prepared By:
Carl Fiochi
LCF Designs

Date: 11-Apr-10

SIPS

Line Number	Description	Quantity	Unit	Total Incl. O&P	Ext. Total Incl. O&P
Division 06 Wood, Plastics, And Composites					
061210000000	Structural Insulated Panels	1		\$0.00	\$0.00
061210100130	Structural insulated panels, 7/16" OSB both faces, EPS insulation, 9-3/8" thick	1	S.F.	\$6.95	\$6.95
Division 06 Wood, Plastics, And Composites Subtotal					\$6.95

Figure 86: 9" SIPS Pricing

BIBLIOGRAPHY

- 2010 Global PV Industry Report. "Fast Solar Energy Facts." *SolarBuzz*. 2010. <http://www.solarbuzz.com/FastFactsIndustry.htm> (accessed April 15, 2010).
- Alexander, H.W. "Designing a Suburban Commercial Center." *American City* 47, 1932: 67.
- Baker, Geoffrey, and Bruno Funaro. *Shopping Centers: Design and Operation*. New York: Reinhold Publishing Corp., 1951.
- Baker, Nick and Steemers.Koen. *Daylight Design of Buildings* . London: James & James, 2002.
- Beyard, Michael D., and Michael PawLukiewicz. *Ten Principles for Reinventing America:s Suburban Strips*. Washington, D.C.: Urban Land Institute, 2001.
- Bureau of Transportation Statistics. "System Mileage Within the United States." *Research and Innovative Technology Administation*. 2008. Bureau of Transportation Statistics:
http://www.bts.gov/publications/national_transportation_statistics/html/table_01_01.html (accessed November 15, 2009).
- Burr, Andrew C. "Sustainability in '09 Reflects Robust '08." *CoStar Group*. January 24, 2009.
<http://www.costar.com/News/Article.aspx?id=922656AF976298910D0A4D1B7E4E0551> (accessed October 2, 2009).
- Cherry, Edith. *Programming for Design: From Theory to Practice*. New York: John Wiley & Sons, 1999.
- Churchill, Winston. *The Dwelling Place of Light*. New York: Macmillan Company, 1917.
- Collins, George R. "The Linear City." *Architects' Yearbook V.2*, 1965: 214-217.
- Cook, John W., and Klotz, Heinrich. "Ugly is Beautiful: The Main Street School of Architecture." *Atlantic Monthly* 231, May 1973: 33-43.
- Edwards, Brian. *Green Buildings Pay, Second Edition*. London and New York: Spon Press, 2003.
- "Energy Efficiency Trends in Residential and Commercial Buildings." *Department of Energy*. October 2008.
http://apps1.eere.energy.gov/buildings/publications/pdfs/corporate/bt_stateindustry.pdf (accessed November 12, 2009).

- Farrell, James J. *One Nation Under Goods: Malls and the Seductions of American Shopping*. Washington, D.C.: Smithsonian Books, 2003.
- Frary, I.T. "The Passing of a Famous Avenue." *Architectural Record* 43, April 1918: 391-392.
- Gifford, Henry. "A Better Way to Rate Green buildings." *Northeast Sun*, Spring 2009: 19-27.
- Glasgow, Corporation Of. *Recent Shopping Developments in Europe*. Glasgow: Corporation of Glasgow, 1971.
- "Green Building Facts." *U.S.Green Building Council*. November 12, 2009.
<http://www.usgbc.org/DisplayPage.aspx?CMSPageID=1718> (accessed November 12, 2009).
- Gruen, Victor & Smith, Larry. *Shopping Towns USA: The Planning of Shopping Centers*. New York: Reinhold Publishing Corporation, 1960.
- Halliday, Sandy. *Sustainable Construction*. Boston: Elsevier, 2008.
- Headwater Resources. *Fly Ash for Concrete*. Document, South Jordan, Utah: Headwater Resources, 2005.
- Hitchcock, Henry Russell. "Traffic and Building Art." *Architectural Record* 68, June 1930: 455-460.
- Hornbeck, James S. *Stores and Shopping Centers*. New York: McGraw-Hill Book company, 1962.
- "Implementation of the Energy Performance of Buildings Directive." *Buildup.eu* . May 14, 2008.
http://www.buildup.eu/system/files/content/EPBD_BuPLa_Country_reports.pdf
(accessed November 19, 2009).
- Kats, Gregory H. *Green Building Costs and Financial Benefits*. PDF, Westwood, Ma.: Massachusetts Technology Collaborative, 2003.
- Kober, Charles. *Shopping Centers and Malls: Book 2*. New York: New York:Retail Reporting Corporation, 1992.
- Kwok, Alison G., and Walter T Grondzik. *The Greenstudio Handbook*. Boston: Elsevier, 2007.
- Kyvig, David E. *Daily Life in the United States, 1920-1939: : How Americans Lived Through the Roaring Twenties and the Great Depression*. The Greenwood Press, 2004.

Liebs, Chester H. *Main Street to Miracle Mile: American Roadside Architecture*. Boston: Little, Brown and Company, 1985.

Littlefair, P.J. *Site Layout for Daylight and Sunlight*. BRE, 1991.

Longstreth, Richard. *City Center to Regional Mall*. Cambridge, Massachusetts: MIT Press, 1997.

—. *The Drive-in, The Supermarket, and the Transformation of Commercial Space in Los Angeles, 1914-1941*. Cambridge, Massachusetts: MIT Press, 1999.

Marketing Green Buildings to Drive Competitive Advantage. Jones Lang LaSalle's Energy & Sustainability Services, 2009.

"Massachusetts Building Code: Seventh Edition." *Executive Office of Public Safety and Security (EOPSS)*. September 2008.
http://www.mass.gov/?pageID=eopsterminal&L=4&L0=Home&L1=Consumer+Protection+%26+Business+Licensing&L2=License+Type+by+Business+Area&L3=Construction+Supervisor+License&sid=Eeops&b=terminalcontent&f=dps_780cmr1&csid=Eeops (accessed November 15, 2009).

McLinden, Steve. *Making Sustainable Development Profitable*. WWW, <http://www.icsc.org/srch/sct/sct0207/index.php>: International Council of Shopping Centers, March 23, 2007.

Modular Building Institute. *Improving Construction Efficiency & Productivity with Modular Construction*. Whitepaper, Charlottesville, VA.: Modular Building Institute, 2010.

Moe, Kiel. *Integrated Design in Contemporary Architecture*. New York: Princeton Architectural Press, 2008.

Moskow, Keith. *Sustainable Facilities: Green Design, Constructions and Operations*. New York: McGraw Hill, 2008.

MPREIS. November 14, 2009.
<http://www.mpreis.com/locations/architecture/architecturedesign/index.htm> (accessed November 14, 2009).

Nye, David E. "Comparing European and American attitudes toward Energy." *Journal of International Affairs*, 1999: 129-149.

Pardy, Sasha M. "CoStar Shines a Light on the Best and Worst Retail Markets in Third Quarter ." *CoStar Group*. October 21, 2009.
<http://www.costar.com/News/Article.aspx?id=8775AB52F61F61025C55BF7F191645E2> (accessed April 15, 2010).

Riley, Robert B. "Understanding the Strip." *Architectural & Engineering News*, January 1968: 32-35.

Runci, Paul. "Renewable Energy Policy in Germany: An Overview and Assessment." *Joint Global Change Research Institute*. January 2005.
<http://www.globalchange.umd.edu/energytrends/germany/1/> (accessed December 17, 2009).

Schwanke, Dean. *Remaking the Shopping Center*. Washington, D.C.: Urban Land Institute, 1994.

Sternlieb, George, and James H. Editors Hughes. *Shopping Centers: U.S.A.* Piscatwey, New Jersey: Rutgers, the State university of New Jersey, 1981.

"Sunderland Zoning Bylaws." *Town of Sunderland*. November 29, 1999.
<http://www.townofsunderland.us/Zoning%20bylaws.htm> (accessed November 15, 2009).

The Columbia Encyclopedia. *Encyclopedia.com*. 2009.
http://www.encyclopedia.com/topic/shopping_center.aspx (accessed November 15, 2009).

Turner 2008 Green Building Market Barometer. 2008.
<http://www.turnerconstruction.com/greenbuildings/content.asp?d=6552> (accessed November 12, 2009).

U.S.Green Building Council. *LEED for Home Rating System*. Document, U.S.Green Building Council, 2010.

Underhill, Paco. *Call of the Mall*. New York: Simon & Schuster, 2004.

Waters, J.R. *Energy Conservation in Buildings*. Oxford: Blackwell Publishing, 2003.

Yorke, Douglas A.J. "Mansard Madness." *Upcountry*, September 1978.

Yudelson, Jerry. *Europe Green Building Trends*. Washington: Island Press, 2009.
—. *Green Building Revolution*. Washington: Island Press, 2008.
—. *Sustainable Retail Development*. New York: Springer, 2009.

Zacks, Stephen. "Form follows Performance." *Metropolis*, 2008.



Figure 87: Night Time
Model and Image by Author