



Model for evaluation of power consumption of vented box loudspeakers

Madsen, Filip Sommer; Thorsen, Søren; Iversen, Niels Elkjær; Knott, Arnold

Published in:
Proceedings of AES 142nd Convention

Publication date:
2017

Document Version
Peer reviewed version

[Link back to DTU Orbit](#)

Citation (APA):
Madsen, F. S., Thorsen, S., Iversen, N. E., & Knott, A. (2017). Model for evaluation of power consumption of vented box loudspeakers. In Proceedings of AES 142nd Convention Audio Engineering Society.

General rights

Copyright and moral rights for the publications made accessible in the public portal are retained by the authors and/or other copyright owners and it is a condition of accessing publications that users recognise and abide by the legal requirements associated with these rights.

- Users may download and print one copy of any publication from the public portal for the purpose of private study or research.
- You may not further distribute the material or use it for any profit-making activity or commercial gain
- You may freely distribute the URL identifying the publication in the public portal

If you believe that this document breaches copyright please contact us providing details, and we will remove access to the work immediately and investigate your claim.



Audio Engineering Society Convention Paper

Presented at the 142nd Convention
2017 May 20–23, Berlin, Germany

This paper was peer-reviewed as a complete manuscript for presentation at this convention. This paper is available in the AES E-Library (<http://www.aes.org/e-lib>) all rights reserved. Reproduction of this paper, or any portion thereof, is not permitted without direct permission from the Journal of the Audio Engineering Society.

Model for evaluation of power consumption of vented box loudspeakers

Filip Sommer Madsen¹, Søren Thorsen¹, Niels Elkjær Iversen¹, and Arnold Knott¹

¹Technical University of Denmark - DTU, Kongens Lyngby, 2800 Denmark

Correspondence should be addressed to Filip Sommer Madsen (Filip_S_Madsen@outlook.dk)

ABSTRACT

In the design of mobile sound systems an estimation of power consumption must be made in order to choose a battery of appropriate size and cost. However poor methods for power estimation tend to result in large and costly batteries. This paper aims to present a more precise method for estimating power consumption for a vented box sound system. Instead of simplifying a loudspeaker system as a purely ohmic resistance, its mechanical and acoustic parameters are used to create a state space model. Despite deviations at high frequencies, the state space model is at least twice as accurate at estimating the power consumption than simplifying the speaker as a resistor.

1 Introduction

Power consumption is an important consideration in most mobile electronic systems. This is no exception in mobile sound systems, where high efficiency is needed to play at a loud level for an extended period of time [1]. Larger batteries ensures longer play time but increases both cost, size and weight. It will therefore always be a trade-off when deciding how large batteries should be used with a given sound system. Finding an appropriate trade-off requires an estimation of the power consumption [2]. The typical approach to estimate the power consumption in sound systems however relies on two major simplifications. First of all speakers are often modelled as purely ohmic resistances [3]. In reality speakers have a frequency varying impedance caused by its mechanical nature and its acoustic surroundings. At frequencies, where the speaker has a high impedance, less current and power will be drawn from the amplifier. This leads to the other simplification which lies in the signal. Music signals consists of a

wide range of frequencies and is known to often have a large dynamic range [4], [5]. However the used signals for testing power consumption are often sinusoids [6]. Because of the frequency dependent nature of speakers, testing with single frequency signals will result in very inaccurate estimations. This paper presents a model to ensure more precise modelling of the power consumption in a sound system. The model is based on the state space representation, which allows the use of complex input signals. This is in contrast to the laplace transform, which can only evaluate sinusoidal signals. By using the state space representation the output current of the amplifier can be estimated, which allows for easy calculation of the average power. The modelled sound system consists of an amplifier driving a speaker placed in a vented box. Vented box speakers are commonly used when small size, large bass response or high efficiency is desired [7]. This is usually the case for mobile sound system, which is the reason for making model a vented box speaker. The model does not take the losses of the amplifier into account, and therefore only the

output power of the amplifier is modelled.

2 Theory

To create a model of a vented box loudspeaker as precise as possible, the fundamental principles of a loudspeaker and how its acoustic surroundings affect it must be considered.

2.1 Fundamentals of loudspeakers

The most typical loudspeaker is the moving coil loudspeaker, which is well described in literature [8], [9], [10]. It is an electro-acoustic transducer, that converts electrical energy into mechanical energy and which is then converted into acoustic energy. In other words the loudspeaker has both electrical, mechanical and acoustic parameters, which should be taken into account when trying to describe its behaviour. Conveniently both the mechanical and the acoustic nature of the speaker can be modelled as electrical circuits, which figure 1 shows.

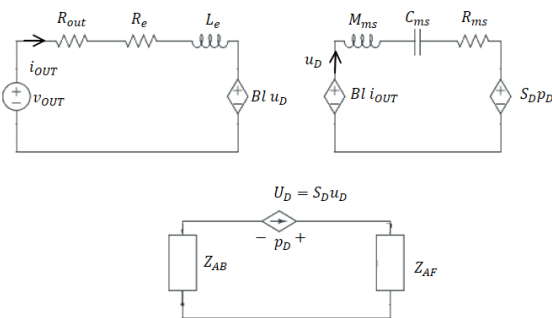

Fig. 1: Equivalent electrical circuit for a speaker

The electrical circuit for a speaker in figure 1 is simplified as being linear. However in real speakers a number of nonlinearities in e.g. the voice coil inductance exists, making the state space model more complex [11]. This is out of the scope of this paper.

The electrical parts of a speaker are coupled to the mechanical ones with the force factor, Bl . The mechanical parts are then coupled to the acoustic one with the effective area of the diaphragm, S_D .

The electrical parameters consist of the dc-resistance in the coil, R_e , along with the inductive behavior of the voice coil, L_e . The mechanical parameters consists of

the mechanical mass, M_{ms} , compliance, C_{ms} and damping, R_{ms} , in the loudspeaker. These parameters are modelled as an electric inductor, spring and resistance respectively. This forms a second order bandpass filter, which determines the resonance frequency of the speaker given by:

$$f_s = \frac{1}{2\pi\sqrt{M_{ms}C_{ms}}} \quad (1)$$

When an output voltage, v_{OUT} , is generated from an amplifier, this gives rise to an electrical current, i_{OUT} . This current creates a mechanical force, $f_D = Bl \cdot i_{OUT}$, which in turn creates a voice coil velocity, u_D . The movement of the coil is translated to the diaphragm, which creates a volume velocity, U_D . The sound pressure, p_D , generated across the diaphragm is then given as follows:

$$p_D = U_D (Z_{ab} + Z_{af}) \quad (2)$$

In the equation above Z_{ab} and Z_{af} are the acoustical impedances at the back and front of the diaphragm respectively. Loudspeakers are sometimes simplified as being mounted in an infinite baffle, where the back and front are isolated. In that case the loudspeaker can be modelled by consisting of only its electric and mechanical parameters.

2.2 State space model of loudspeaker

To create a model of the speaker system which can evaluate complex input signals a state space model can be used. The state space representation is a way to mathematically describe dynamic systems in the time domain. The model made up of coupled first-order ordinary differential equations expressed in the following form:

$$\dot{\mathbf{x}}(t) = \mathbf{F}\mathbf{x}(t) + \mathbf{G}\mathbf{u}(t) \quad (3)$$

Here $\mathbf{x}(t)$ is the state vector describing the current state of the system and $\dot{\mathbf{x}}(t)$ is its derivative. \mathbf{F} describes the system dynamics and is called the state matrix. \mathbf{G} is the input matrix describing how the input affects the state variables. A state space model of a loudspeaker has been found in [12] which has been rearranged into:

$$\mathbf{x}(t) = \begin{bmatrix} i_{OUT} \\ x_D \\ u_D \end{bmatrix} \mathbf{G} = \begin{bmatrix} -\frac{1}{L_e} \\ 0 \\ 0 \end{bmatrix} \quad (4)$$

Here x_D is the displacement in the mechanical spring.

$$\mathbf{F} = \begin{bmatrix} -\frac{R_e}{L_e} & 0 & -\frac{Bl}{L_e} \\ 0 & 0 & 1 \\ \frac{Bl}{M_{ms}} & -\frac{1}{C_{ms}M_{ms}} & -\frac{R_{ms}}{M_{ms}} \end{bmatrix} \quad (5)$$

Note that in the state space model above the acoustic impedances Z_{af} and Z_{ab} are assumed to be only acoustic masses, which are included in the mechanical mass, M_{ms} . Placing the speaker in a vented box increases the significance and complexity of the acoustic system, which will be examined next.

2.3 Effects of a vented box

Mounting a loudspeaker in a box has several advantages. It prevents the back of the speaker, which radiates 180° out of phase, from causing destructive interference at the front. This increases the bass response. However it also adds an acoustic volume, which acts as an extra mechanical spring increasing the resonance frequency of the system. If lower bass response, small size or higher efficiency is needed a vented box can be used. Figure 3 shows the electrical model of the vented box system. This adds an acoustical mass, M_{ap} , which together with the acoustic volume, V_{ab} , forms a second order band pass filter. The phase delay from the back to the front will then be $180^\circ + 180^\circ = 360^\circ$, which makes it radiate in phase with the speaker, boosting the output.

2.3.1 Impedance of a vented box

Figure 2 shows the frequency dependent impedance of a loudspeaker in a vented box. The minimum impedance is found at 0 Hz as the voice coil DC-resistance. At high frequencies the impedance is seen to rise which is due to the inductive behavior of the voice coil. In reality the voice coil also has a lossy behavior [8], which due to simplification will not be examined in this paper.

Two peaks are present. The higher one is due to the mechanical nature of the speaker. The lower one is

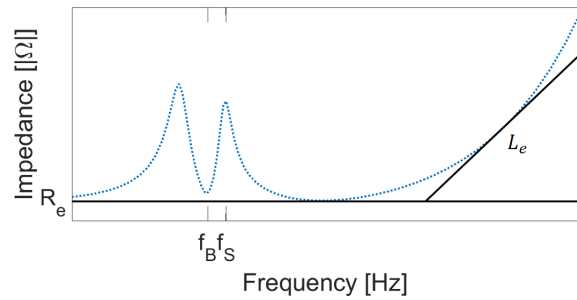

Fig. 2: Impedance of a speaker in a vented box

caused by the vent, and the null between is the resonance frequency of the vent and the acoustic volume. By ohms law it is clear that the speaker will draw the less power at these impedance peaks.

2.3.2 Electrical equivalent circuit of a vented box

The equivalent electrical for a speaker in figure 1 can be expanded to include the acoustic parameters of a vented box, which is shown in figure 3.

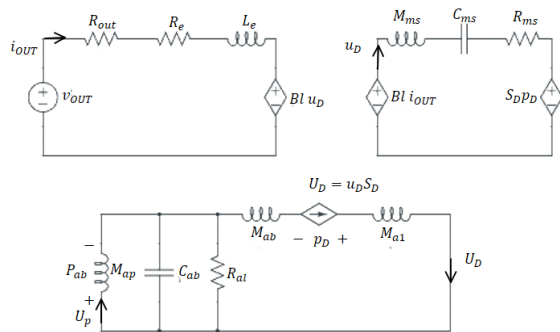

Fig. 3: Electrical equivalent circuit for a speaker in a vented box

The resistance R_{al} in figure 3 models the air-leakage through the box. M_{a1} and M_{ab} model the radiation impedance on the front and in the box respectively. This is somewhat a low frequency simplification, and a more precise modelling of radiation impedance can be implemented in future work. Doing so will cause the size of the state space model to increase significantly.

2.3.3 State space model of vented box

By placing the speaker in a vented box the state space model presented in section 2.2 is no longer valid. There-

fore a new state space model is to be made in order to describe the expanded system.

The state variables in $x(t)$ from equation 3 are found by analyzing all energy storing elements in figure 3. For capacitors the state variable will be the voltage and for inductors it will be current. The found state vector is:

$$x(t) = \begin{bmatrix} i_{OUT} \\ x_D \\ u_D \\ p_{ab} \\ U_p \end{bmatrix} \quad (6)$$

Here U_p is the volume velocity in the port. p_{ab} is the sound pressure in the acoustic volume, which is equivalent to the voltage across a capacitor. U_D , which is stored in M_{ab} and M_{a1} , is not needed to take account for because it is equal to $u_D S_D$. Now the derivative to each state variable must be expressed by the other state variables. $\frac{di_{OUT}}{dt}$ and $\frac{du_D}{dt}$ can be solved for in equation 7 and 8 respectively, which are found from using Kirchhoff's voltage law in the electric and mechanical circuit.

$$v_{OUT} = i_{OUT} R_e + L_e \frac{di_{OUT}}{dt} + B l u_D \quad (7)$$

$$B l i_{OUT} = u_D R_{ms} + M_{ms} \frac{du_D}{dt} + x_D \frac{1}{C_{ms}} + p_D S_D \quad (8)$$

The derivative of the mechanical displacement, x_D , is simply the mechanical velocity:

$$\frac{dx_D}{dt} = u_D \quad (9)$$

The derivative of the volume velocity through the port can be found from the relation between voltage change in current in an inductor. Translating acoustic pressure into voltage and volume velocity into current it can be shown that:

$$p_{ab} = M_{ap} \frac{dU_p}{dt} \quad (10)$$

Lastly the derivative of the pressure in the box can be found from using Kirchhoff's current law along

with the relation for voltage change and current in a capacitor:

$$u_D S_D - U_p - \frac{p_{ab}}{R_{al}} = C_{ab} \frac{dp_{ab}}{dt} \quad (11)$$

Solving for the derivatives of each state variable in equation 7, 8, 9, 10 and 11, the state matrix can now be found as:

$$\mathbf{F} = \begin{bmatrix} -\frac{R_e}{L_e} & 0 & -\frac{B l}{L_e} & 0 & 0 \\ 0 & 0 & \frac{1}{R_{ms}} & 0 & 0 \\ \frac{B l}{M_{tot}} & -\frac{1}{C_{ms} M_{tot}} & -\frac{1}{M_{tot}} & 0 & -\frac{S_D}{M_{tot}} \\ 0 & 0 & 0 & 0 & \frac{1}{M_{ap}} \\ 0 & 0 & \frac{S_D}{C_{ab}} & -\frac{1}{C_{ab}} & -\frac{1}{R_{al} C_{ab}} \end{bmatrix} \quad (12)$$

In the state matrix above the term M_{tot} is equal to $(M_{a1} + M_{ab}) S_D^2 + M_{ms}$.

The only state variable depending on the input, v_{OUT} , is i_{OUT} . Solving for $\frac{di_{OUT}}{dt}$ in equation 7 makes it straightforward to set up the input vector, \mathbf{G} .

$$\mathbf{G} = \begin{bmatrix} 1 \\ L_e \\ 0 \\ 0 \\ 0 \\ 0 \end{bmatrix} \quad (13)$$

2.4 Speaker model for estimation of average input power

By using the established state space model it is now possible to estimate the output current, $i_{OUT}(t)$, when exciting the speaker with an arbitrary voltage signal, $v_{OUT}(t)$. The instantaneous power is achieved by multiplying $i_{OUT}(t)$ and $v_{OUT}(t)$. The instantaneous power contains both the real and reactive parts of the power, but when evaluating power consumption, only the real power is of interest. Since the reactive power simply moves back and forth between energy storing elements, this part will approximately be reduced to zero when integrating over a long period of time. To find the average input power the one must simply divide by the period. The measured average output power can therefore be calculated as:

$$P_{out,avg} = \frac{1}{t_2 - t_1} \int_{t_1}^{t_2} i_{OUT}(t)v_{OUT}(t)dt \quad (14)$$

This model will for the future be referred to as the speaker model.

2.5 Simple resistor model

For the sake of comparison a simple model has been made to simulate the power consumption when the loudspeaker is modelled as a purely ohmic resistance. This model simply estimates the output current by:

$$i_{OUT} = \frac{v_{OUT}}{R_e} \quad (15)$$

Hereafter the average input power is again calculated using equation 14. This model will for the future be referred to as the resistor model.

3 Implementation

In this section the specific speaker and vented box used in the measurements are described. Also the test setup is explained along with the method for measuring the average output power. Furthermore it explains how the average output power is to be estimated through simulations.

3.1 Calculation of component values

The values of the components in the circuit shown in figure 3 are a mix of calculated and found. The electric and mechanic values are obtained directly from the Thiele Small parameters of the loudspeaker [13], which are shown in table 1. For higher precision these values can be measured [14]. The speaker is a small 3" low frequency driver with a free air resonance frequency of 55 Hz.

The only parameter in table 1, which is not taken directly from the datasheet, is the mechanical dampening R_{ms} . This has been estimated from:

$$R_{ms} = \frac{1}{Q_{ms}} \sqrt{\frac{M_{ms}}{C_{ms}}} \quad (16)$$

The speaker has been placed in a custom made vented box. The acoustic values have been calculated based of

Table 1: Thiele Small parameters for the loudspeaker used

Parameter	Value	Unit
R_e	3.6	Ω
L_e	0.19	mH
M_{ms}	9.98	g
C_{ms}	737.67	$\mu\text{m}/\text{N}$
R_{ms}	1.16	Kg/N
Bl	5.28	Tm
S_D	0.0027	m^2
Q_{ms}	3.17	

the dimensions of the box and the vent and using formulas from [8]. The box size, V_{ab} , is approximately 3.2 liters, which gives the following acoustic compliance of the box:

$$C_{ab} = \frac{V_{ab}}{\rho_0 c^2} = 22.48 \cdot 10^{-9} \text{m}^5/\text{N} \quad (17)$$

The acoustic mass in the port, M_{ap} , is found from the cross section area, S_p , and the length of the port, L_p by:

$$M_{ap} = \frac{\rho_0}{S_p} \left(L_p + 1.462 \sqrt{\frac{S_p}{\pi}} \right) = 261.73 \text{Ns}/\text{m}^5 \quad (18)$$

To calculate the acoustical dampening, R_{al} , coming from air leakage in the box, a value for the vented box quality factor, Q_L , must be found. Because the volume of the box is quite small, a high Q_L value of 20 is assumed [8]. This gives an acoustical dampening of:

$$R_{al} = \frac{1}{Q_L} \sqrt{\frac{M_{ap}}{C_{ab}}} = 2.17 \text{Ns}/\text{m}^5 \quad (19)$$

The radiation impedance on the front of the diaphragm, M_{a1} , is a low frequency simplification and found by:

$$M_{a1} = \frac{8\rho_0}{3\pi^2 a} = 11.1 \text{kg}/\text{m}^4 \quad (20)$$

Here a is the effective radius of the diaphragm given by:

$$a = \frac{\sqrt{S_D}}{\sqrt{\pi}} \quad (21)$$

Lastly the acoustic mass of the air in the box, M_{ab} is found by:

$$M_{ab} = \frac{B\rho_0}{\pi a} = 8.5\text{kg/m}^4 \quad (22)$$

Here the mass loading factor, B , is assumed to be 0.65 [8].

3.2 Test setup

The test setup is shown in figure 4, and consists of a power supply, a class-D amplifier and the vented box loudspeaker. Figure 5 shows the actual setup.

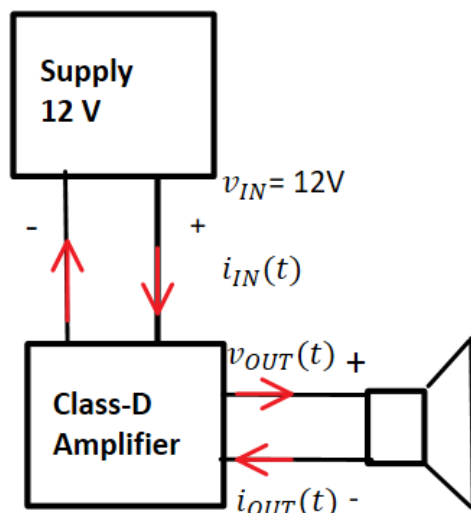

Fig. 4: Block diagram of test setup

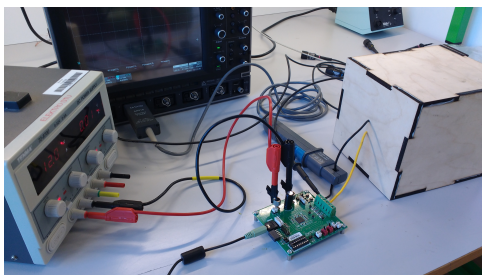

Fig. 5: Test setup

Both conduction and idle losses are present in the amplifier, but by measuring $i_{OUT}(t)$ and $v_{OUT}(t)$, these losses are not relevant for calculating the output power.

For the test setup in figure 5 the MA12040P amplifier chip from Merus Audio was used [15].

The goal of the measurement is verifying the average output power found in the simulations, defined in equation 14 can be used to predict the power consumption more accurately than the simple resistor model.

The measurements are carried out on a LeCroy WaveSurfer 104MXs-B oscilloscope by tracing the current with current probes, as well as measuring the voltage. Since the oscilloscope works by taking samples in the discrete time domain the average output power can be found by:

$$P_{out,avg} = \frac{1}{T} \sum_{n=0}^N v_{OUT}[n] \cdot i_{OUT}[n] \quad (23)$$

Where N is the number of samples used, and T is the period the measurement is taken over.

Since the audio files being played through the speaker has a sample rate of 44.1kHz, the oscilloscope needs to have a sample rate, f_s , equal to or higher than this. The specific scope used can store 1 million samples at a time. Choosing a sample rate of 50 kHz the measurement period is found to be 20 seconds, using equation 24.

$$\frac{N}{f_s} = T \quad (24)$$

If a larger time interval would be chosen, aliasing would occur at higher frequencies, and the results would come up incorrect.

4 Results

To verify the validity of the represented state space model, measurements have been made. These measurements have been compared to simulations of both the speaker and the resistor models.

4.1 Measurements with sinusoid signals

Theory predicts that the frequency varying loudspeaker impedance will cause the average input power to vary as well. However if modelled as a resistor, the average input power will be constant for all frequencies. To examine which model is most precise a number of measurements with sinusoids of 12 V peak at different frequencies has been made. Figure 6 shows the results. No measurements were made below 45 Hz, fearing that this would damage the speaker unit.

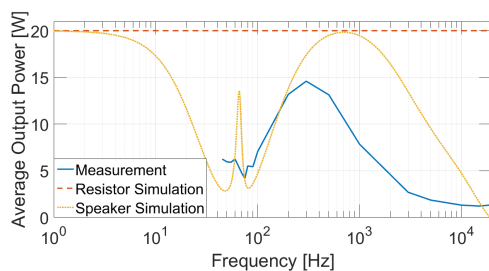

Fig. 6: Comparison between simulations and measurements at different frequencies

What is first to notice in figure 6 is that the measured average input power varies quite a lot. The simulation of the resistor model however is constant and does at all frequencies predict a larger power consumption. This is expectable since the highest current draw will occur when the loudspeaker impedance equals its dc-resistance. Especially at frequencies above 1 kHz the resistor model is very inaccurate. The loudspeaker model however generally does a better job predicting the measured average input power. Around the port and driver resonances the simulation is quite close compared to the resistor model. However the loudspeaker simulation generally predicts larger variations. Also in the range from 100 Hz to 300 Hz the two slopes seems to be offset by around 30 Hz. This could very well be because of imprecise speaker parameters from the datasheet. For instance a higher compliance or smaller mass will move the driver resonance up in frequency. However it should be stated that all formulas used to calculate the acoustical parameters are approximations, which might have lead to deviations. The largest deviation for the speaker simulation starts at above 500 Hz. This is most likely due to imprecise modelling of the self inductance in the voice coil. Predicted from the datasheet value of L_e , the voice coil impedance

should start rising above 1 kHz. However from the impedance plot of the speaker in free air in from the datasheet, the impedance starts rising above 300 Hz [13]. This corresponds very nicely with the measured result, and a much more precise speaker model above 300 Hz would be expected, if the modelling of the voice coil inductance were more precise. To examine the accuracy of the simulations further, the deviation of the measurement and the simulations has been calculated in percentage. The deviation in percent is found by:

$$\text{Deviation} = \frac{\text{Simulated result} - \text{Measured result}}{\text{Measured result}} 100\% \quad (25)$$

Using the above formula for both simulations, the deviations in figure 7 are obtained. The frequency axis is limited to go up to 500 Hz, which is because at higher frequencies large deviations occur due to the imprecise modelling of the self inductance. Also since the driver is a low frequency driver, the higher frequencies are irrelevant since a low pass filter would be used with the speaker.

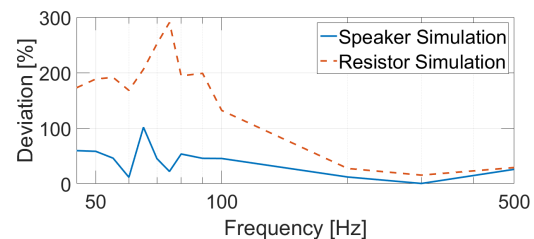

Fig. 7: Deviation between simulations and measurement at different frequencies

Figure 7 shows that the speaker model at all frequencies is more precise than the resistor model. While the resistor model goes up to maximum of 300 %, the speaker model mostly stays under 50 %. The largest deviation of the speaker model is around 65 Hz, which is close to the port resonance. This deviation is most likely due to the acoustic system being simplified, neglecting more complex acoustic phenomena and the non ideal speaker implementation. However at around 300 Hz, where the speaker draws a lot of power, the speaker model is very accurate. At 75 Hz the speaker model deviates with only 22 %, while the resistor deviates 290 %. In other words at this frequency the speaker model is more than 10 times more accurate than the resistor model. This is a big improvement, especially because of the fact, that the speaker is a low frequency driver typically operating around this frequency.

4.2 Measurements with complex signals

One of the major advantages of using the state space representation for modeling the speaker is, that complex signals can be used as inputs. It is therefore important to verify how correctly the model can predict the average input power for such signals. To do this the white and pink noise signals along with the IEC 268-5 signal have been sent through the speaker. The IEC 268-5 signal is a measuring signal based on pink noise, but with roll off at low and high frequencies [16], which gives it more characteristics of a music signal. The three signals have also been used as inputs to both the resistor model and speaker model. Table 2 shows the results of this along with the measured average input power. Due to the fact that the amplitude of the three signals varied a bit, a peak normalization has been made in the simulations. This can lead to deviations.

Table 2: Average output power for speaker and resistor simulations along with measured data

	White Noise	Pink Noise	IEC
Measured[W]	0.41	0.35	0.94
Speaker[W]	0.83	0.44	1.56
Resistor [W]	15.81	0.95	2.00

Both the simulation of the speaker and the resistor generally predicts higher power consumption than measured. However for all three measurements the simulation of the speaker is closer than it is for the simulation of the resistor. Especially for inputs of white noise the resistor does a poor job predicting the correct average input power. This has most likely something to do with the resistor simulation giving large deviations at high frequencies. As both pink noise and the IEC 268-5 signal has a roll off at high frequencies, the deviation is much smaller for these signals.

Table 3: Percentage deviations between both simulations and the measurements

	White Noise	Pink Noise	IEC
Speaker [%]	102.44	25.71	65.96
Resistor [%]	3756.09	171.43	112.76

In table 3 the percentage deviations for the same measurements are shown. Here it is even clearer to see that with simulation a resistor overall gives poor results.

This is especially true for signals containing high frequency content. The state space model for the speaker however is down to 25.71 % deviation for the pink noise signal, which is more than six times less than for the resistor model, which is at 171.43 %. For the IEC 268-5, where the resistor model performs its best with a deviation of 112.76 %, the speaker model still has an accuracy almost twice as good. Though the deviations for the speaker model could be smaller it should be kept in mind the large amount assumptions and approximation that have been made when creating the model. Apart from calculations of the acoustic parameters, this includes assuming datasheet parameters to be correct. It was also found that numerical errors would appear at above 10 kHz. This along with the poorly simulated voice coil inductance is most likely the main reason why the loudspeaker model performs better with pink noise and IEC 268-5 than white noise.

4.3 Simulation with music signals

The model was also simulated using real music, in this case, the top 50 tracks from Billboard Hot 100¹ as of 15/12/16, were loaded into the simulation with a peak amplitude of 12 V.

Table 4: Average input power for speaker and resistor simulations for music

	Billboard
Speaker [W]	1.34
Resistor [W]	2.49

This continues the trend of the resistor using more power than the real speaker, According to [6] the average audio signal has a characteristics comparatively close to that of the IEC 268-5 signal, and comparing table 2 and 4 their power consumption are fairly similar.

The results generally show that the state space model of the vented box loudspeaker is much more precise than by approximating the speaker as a resistor. At all frequencies the loudspeaker model estimates a lower power consumption than the resistor model does. In other words when estimating minimum requirements for batteries in a given sound system, one would always end out with a smaller and cheaper solution. One could argue that due to the fact that the loudspeaker

¹<http://www.billboard.com/charts/hot-100>

model at some frequencies underestimates the power consumption, a safety margin of a few watts should be added. Because the model at all three test signals overestimates the power consumption, this should not be necessary, however if a different driver with more reliable parameters, and a better implemented cabinet were to be used, this might be an issue to address.

5 Conclusion

Power consumption is generally a big concern in mobile sound systems, as it decides the size and price of batteries. When modelling a loudspeaker as a purely ohmic resistance, the result is an overestimation of power consumption. This leads to larger and more expensive batteries. In an attempt to avoid this, this paper has presented a state space model of a loudspeaker in a vented box. Measurements of the average input power for sinusoid signal with different frequencies were performed. These were compared to simulated values for the state space model of the vented box speaker, but also for a simple solution where the speaker is modelled as a purely ohmic resistance. Though both simulation types showed deviation, especially at above 500 Hz, the state space model of the loudspeaker was clearly more precise. Furthermore it is assumed that imprecise values from the loudspeaker datasheet, as well as an imperfect enclosure could be one of the major reasons for large deviations. Apart from this the loudspeaker showed deviations of less than 50% across large frequency areas, where the resistor model showed up to 300% deviations. Also a set of measurements with the more complex signal white noise, pink noise and IEC 268-5 were performed. Here both simulations showed to overestimate the power consumption in all three cases. However the loudspeaker model showed to perform significantly better than the resistor model. For pink noise the deviation for the loudspeaker model was found to be around 50%, whereas the resistor was found to deviate around 200% - 4 times worse. Lastly simulations with top 50 billboard music tracks were performed to demonstrate the capabilities of the model, being able to simulate power consumption when playing music signals. In short there is clearly a potential for using state space representation for modelling power consumption more precisely in sound systems. The speaker model performed significantly better than the resistor model in all measurements. The relatively large deviations at certain frequency ranges are expected to be reduced significantly by future optimization.

6 Acknowledgements

The authors would like to thank Ruben Bjerregaard from Soundboks, and Rien Oortgiesen from Merus Audio for supplying equipment and being helpful in answering any questions regarding this.

References

- [1] Iversen, N. E., Oortgiesen, R., Knott, A., Andersen, M. A., and Høyerby, M., "Design of efficient sound systems for low voltage battery driven applications," in *Audio Engineering Society Convention 141*, Audio Engineering Society, 2016.
- [2] Schneider, H., Jensen, L. C., Petersen, L. P., Knott, A., and Andersen, M. A., "Requirements Specification for Amplifiers and Power Supplies in Active Loudspeakers," in *Audio Engineering Society Convention 137*, Audio Engineering Society, 2014.
- [3] Iversen, N. E. and Knott, A., "Small Signal Loudspeaker Impedance Emulator," *Journal of the Audio Engineering Society*, 62(10), pp. 676–682, 2014.
- [4] Mijic, M., Masovic, D., Sumarac Pavlovic, D., and Petrovic, M., "Statistical properties of music signals," in *Audio Engineering Society Convention 126*, Audio Engineering Society, 2009.
- [5] Iversen, N. E., Schneider, H., Knott, A., and Andersen, M. A., "Efficiency Investigation of Switch-Mode Power Audio Amplifiers Driving Low Impedance Transducers," in *Audio Engineering Society Convention 139*, Audio Engineering Society, 2015.
- [6] Niels Elkjær Iversen, A. K. and Andersen, M. A. E., "Efficiency of Switch-Mode Power Audio Amplifiers - Test Signals and Measurement Techniques," 2016.
- [7] Small, R. H., "Efficiency of Direct-Radiator Loudspeaker Systems," *Journal of the Audio Engineering Society*, 19(10), pp. 862–863, 1971.
- [8] W. Marshall Leach, J., "Introduction to electroacoustics & audio amplifier design, Fourth Edition," 2010.

-
- [9] Thiele, N., “Loudspeakers in vented boxes: Part 1,” *Journal of the Audio Engineering Society*, 19(5), pp. 382–392, 1971.
- [10] Thiele, N., “Loudspeakers in vented boxes: Part 2,” *Journal of the Audio Engineering Society*, 19(6), pp. 471–483, 1971.
- [11] Klippel, W., “Loudspeaker Nonlinearities—Causes, Parameters, Symptoms,” in *Audio Engineering Society Convention 119*, Audio Engineering Society, 2005.
- [12] Brunet, P., *Nonlinear System Modeling and Identification of Loudspeakers*, Ph.D. thesis, Citeseer, 2014.
- [13] “tb-speaker,” <http://www.tb-speaker.com/products/w3-1876s>, n/a, accessed: 15-12-2016.
- [14] Chapman, P. J., “Quantifying Acoustic Measurement Tolerances and Their Importance in the Loudspeaker Supply Chain,” in *Audio Engineering Society Convention 136*, Audio Engineering Society, 2014.
- [15] “MA12040P Merus Amplifier,” <http://www.merus-audio.com/images/pdf/MA12040P.pdf>, n/a, accessed: 07-01-2017.
- [16] “jblpro,” <https://www.jblpro.com/pub/technote/spkpwfaq.pdf>, n/a, accessed: 15-12-2016.