

Small-scale chicken production

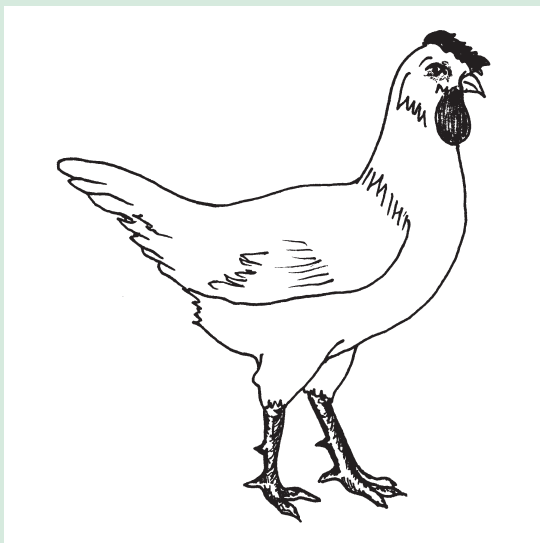
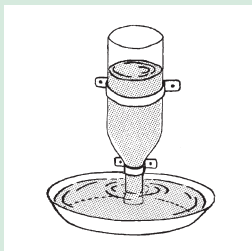
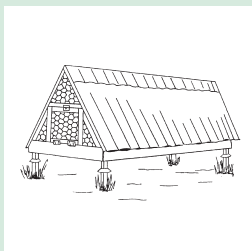

Agrodok 4

Small-scale chicken production

N. van Eekeren
A. Maas
H.W. Saatkamp
M. Verschuur

This publication is sponsored by the World's Poultry Science Association (WPSA)

© Agromisa Foundation and CTA, Wageningen, 2006

All rights reserved. No part of this book may be reproduced in any form, by print, photocopy, microfilm or any other means, without written permission from the publisher.

First edition: 1990

Fourth revised edition: 2006

Authors: N. van Eekeren, A. Maas, H.W. Saatkamp, M. Verschuur

Editors: F. W. Aghdam, J. Boland

Design: J. Boland

Translation: I. Guijt, W.J. Guijt; C. McGregor (editing)

Printed by: Digigrafi, Wageningen, The Netherlands

Revised by: G. W. Bouwman, G. de Lange and I. Puls

ISBN Agromisa: 90-8573-069-4

ISBN CTA: 978-92-9081-347-7

Foreword

This Agrodok provides a wealth of useful information on how to overcome the main constraints in small-scale poultry production and deal with threats like predation and infectious diseases. It is a practical booklet with chapters on hatching, housing, nutrition and health. I sincerely hope and believe that the knowledge, tools and experiences offered here will be a valuable resource for poultry keepers. Above all, I hope that it will inspire readers to generate new ideas through applying the ideas they find here.

Chickens deserve to be treated well – and professionally. You will see that the birds will show their gratitude by improving their performance! I wish you a healthy flock and a successful enterprise!

Dr. René P. Kwakkel

Wageningen University - Poultry Nutrition Research

This edition has been revised by Ineke Puls, Gert Wouter Bouwman and Gert de Lange of PTC⁺, Barneveld, under the guidance of Farzin Wafadar Aqhdam. Agromisa kindly acknowledges their contributions and critical comments. We also acknowledge the financial support of the World's Poultry Science Association, which made it possible to publish this Agrodok in several languages.

A number of illustrations used in this Agrodok derive from the Network for Smallholder Poultry Development ('Poultry Network'), USDA Animal and Plant Health Inspection Service (APHIS) and the Newcastle Disease Field Guide by Alders and Spradbrow (ACIAR). The nutrition tables were provided by PTC⁺ and are based on a variety of sources.

Jeroen Boland

Agromisa

Contents

1	Introduction	6
2	Chicken breeds	8
2.1	Commercial and hybrid breeds	8
2.2	Local breeds	10
2.3	Choosing a chicken breed	11
3	Housing	13
3.1	Free-range chickens	14
3.2	Small-scale housing	17
3.3	Some housing options	19
4	Housing equipment	23
4.1	Feeders	23
4.2	Drinkers	26
4.3	Perches	27
4.4	Laying nests	28
5	Nutrition	33
5.1	Water	34
5.2	Energy requirements	34
5.3	Protein requirements	36
5.4	Vitamin requirements	37
5.5	Mineral requirements	37
5.6	Other ingredients in chicken diets	39
6	Feeding methods	40
6.1	Feeding in various housing systems	40
6.2	Feed intake	41
6.3	Restriction of energy intake	44
6.4	Feed composition	45

7	Health care	49
7.1	Infectious diseases and their causes	49
7.2	Hygiene and biosecurity	53
7.3	Vaccination	56
7.4	Parasites and feather pecking	58
8	Hatching and raising chicks	60
8.1	Hatching using brooding hens	60
8.2	Artificial hatching	61
8.3	Raising the chicks	62
9	Improving local chickens	65
9.1	Cock exchange programmes	65
9.2	Culling	65
10	Products and by-products	67
11	Farm records	69
11.1	Important data	69
11.2	Cost pricing	71
	Appendix 1: Diseases and parasites	73
	Appendix 2: Nutrition tables	76
	Appendix 3: Common feedstuffs	83
	Further reading	87
	Internet sites	89
	Useful addresses	90

1 Introduction

Chickens in extensive and semi-intensive poultry production systems account for more than 75% of all poultry in the South. Owned by smallholders in rural areas, these birds provide food security and family income and play an important role in socio-cultural events.

Poultry is an important farm species in almost all countries. It is an important source of animal protein, and can be raised in situations with limited feed and housing resources. Chickens are ‘waste-converters’: they ‘convert’ a scavenged feed resource base into animal protein. They are therefore by far the most important species for generating income for rural families.

People raise chickens all around the world under widely varying circumstances. Their main objective is generally the same: maximum production for minimum costs and with minimum risks.

The two main forms of keeping small-scale chicken are small-scale subsistence farming and commercial farming. If poultry is mainly kept for home consumption of eggs and meat, costs and effort can be kept to a minimum. But for a poultry enterprise to be successful, it must have a reliable market for its products and a steady supply of reasonably priced quality feed. It is important that feed resources are locally available. See figure 1.

This Agrodok refers mainly to semi-intensive farming. It can help beginners and experienced poultry raisers to solve problems that come up. Its focus is on keeping layers. Keeping broiler poultry presents different problems and requires particular expertise. Nevertheless, some attention will be paid to keeping cocks as these have to be fattened too.



Figure 1: A chicken breeder has to reflect on many subjects

This booklet deals with housing, chicken feed, health issues, natural breeding and raising chicks and administration.

2 Chicken breeds

All over the world, more than 300 breeds of the domestic chicken species (*Gallus domesticus*) exist. We distinguish three main categories of chicken breeds: pure commercial breeds, hybrid breeds resulting from cross-breeding, and local breeds or land races.

We can roughly divide commercial breeds according to their main production aim:

- egg laying, mainly with lightweight laying breeds or *layers*
- meat production, mainly by heavyweight breeds or *broilers*
- both egg-laying and meat production by so-called *dual-purpose* breeds.

Layer, broiler and dual purpose breeds can be distinguished according to their shape. See figure 2.

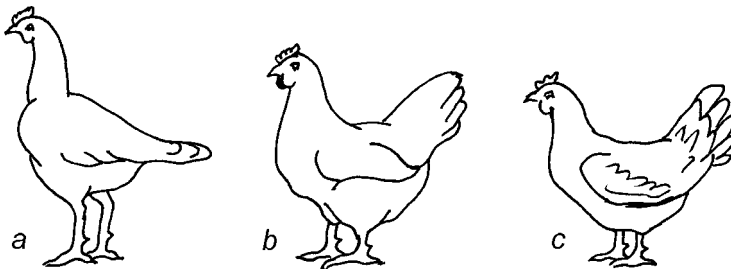

Figure 2: Typical breeds: (a) layer (b) broiler (c) dual purpose (Poultry Network)

2.1 Commercial and hybrid breeds

A wellknown lightweight layer breed is the White Leghorn (figure 3). White Leghorns are known for laying lots of white eggs. They need less feed, due to their small size. White Leghorns are therefore very efficient layers. At the end of the laying period they give relatively little meat.

Some heavier layer breeds are meatier and still lay many eggs. These are hence fit for dual-purpose production. These chickens lay brown eggs and usually have brown feathers, but this can vary per breed. We mention the brown-coloured Rhode Island Red (figure 4) and the light-brown New Hampshire (figure 5). These are kept for both meat and egg production and can hence be categorized as dual-purpose breeds. Heavier dual-purpose breeds are very suited to small-scale chicken raising in the tropics. They are usually sturdier than the light breeds.

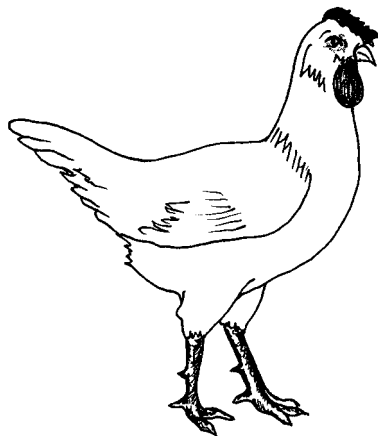

Figure 3: White Leghorn

Medium-weight and heavy chicken breeds are raised for meat production. Cocks of medium-weight chicken breeds can also be kept for slaughtering. Breeds like White Cornish and White Plymouth Rock are important meat producer breeds and hence better suited as pure broiler chickens.

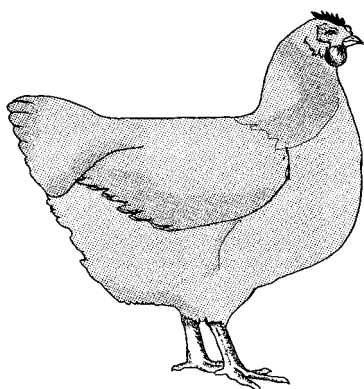

Figure 4: Rhode Island Red

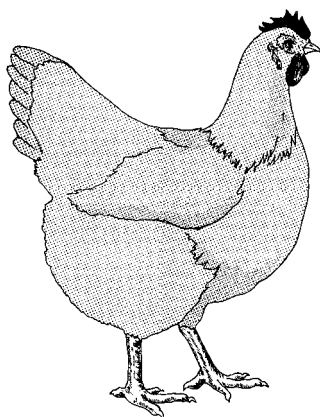

Figure 5: New Hampshire

These heavier birds have more muscle. They grow fast and can quickly reach a high slaughter weight. This requires plenty of high quality feed. It requires special skills to keep this in good supply and balance.

Hybrids or cross-breeds result from combining special lines or strains of chickens developed for this purpose with e.g. a local breed. The hybrids are more productive. In countries in the South, cross-breeding between pure breeds is also common, e.g. White Leghorn crossed with Rhode Island Red. Nowadays hybrid breeds have become very common.

2.2 Local breeds

If you want to breed your own stock of chickens, you cannot go on using the hybrid breeds, as their high productivity will go down. You can only get high production with hybrid layers if you buy chickens regularly. It is therefore advisable to use local breeds, which are often much cheaper to keep. Another advantage of local chicken breeds is that they are better adapted to local conditions and are less susceptible to diseases than the more fragile hybrids. Local breeds are usually lighter in weight and have smaller eggs than those of hybrid breeds.

Local breeds can be distinguished according to their appearance. See figure 6.

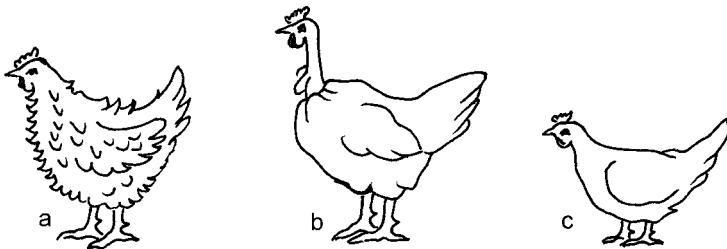

Figure 6: Local breed types: (a) frizzle feather (b) naked neck (c) dwarf (Poultry Network)

However, local chickens are far less productive in terms of egg numbers. In rural areas, local chickens lay about 50 eggs per year, while hybrids can lay 250-270 eggs a year under favourable conditions. On the other hand, local breeds make better use of waste material than hybrid chickens do, so they are more suitable for keeping around the house.

This booklet discusses various factors influencing egg production and methods for improving it, with the aim of reaching medium to high production levels.

2.3 Choosing a chicken breed

Important factors when choosing the best breed of chickens for your situation are: price, market situation, experience, farm management, local preference and availability.

The *price* will determine your choice. Modern hybrids are very expensive. They also need very good care and high quality, balanced feed to be productive. Local breeds are cheaper and better adapted to local conditions. With adequate care, they are reasonably productive. However, if you want to raise chickens on a larger scale and decide to buy balanced feed, it is better to choose the more expensive hybrids.

It is important to consider the *local market situation*. Medium-weight hybrids should only be chosen if there is a good market for eggs and meat and a steady supply of good, balanced chicken-feed. If you want to concentrate on selling eggs, consider buying lighter, white layers. In all other situations, the heavier, usually brown breeds would be a better choice. If you live far from a market and mainly want to produce for home consumption, only selling extra eggs and meat locally, you are best off with a local breed.

If you have no *experience* of raising chickens, it is best to start with a cheaper, local breed.

If *farm management* is good, you can buy the more expensive and profitable hybrids.

In some countries *local preference* favours brown eggs.

Hybrids are not always locally available, so you will be dependent on what can be obtained in your area.

3 Housing

We distinguish three forms of chicken farming:

- extensive farming
- intensive farming
- semi-intensive farming.

In this Agrodok, we mainly refer to the extensive and semi-intensive farming. Intensive farming with e.g. battery cages will not be treated.

When chickens are free to roam and scavenge, we talk about *extensive*, free-range chicken farms. The level of capital and labour investment is low. Housing is not important.

Intensive systems, developed for specialised breeds, are estimated to be in use for about 30% of the poultry population in Africa. These are mainly found in and around urban areas with good markets for eggs and chicken meat. Intensive chicken farms require more investment of both capital and labour, e.g. special poultry houses with runs or roaming space. Flock sizes in intensive production are normally in the thousands. This has been made possible by research developments in artificial incubation, nutritional requirements and disease control.

In the *semi-intensive* production system, also known as backyard production, flocks range from 50 to 200 birds. A lot of techniques and expertise developed in intensive systems can be applied in semi-intensive poultry raising systems, adapted to the adequate scale.

In both the semi-intensive and intensive production systems, housing is very important for optimal production levels. See sections 3.2 and 3.3.

3.1 Free-range chickens

In the free-range system, chickens are free to roam the farm in search of food. Eggs are laid outside in simple nests and are mainly used to maintain chicken numbers. In many cases, up to 75% of the eggs have to be hatched because the mortality rate among baby chicks is high. Few eggs remain for consumption and the chickens themselves do not give much meat.

The advantages of this system are that little labour is needed and waste food can be used efficiently. Very low costs can offset low production levels so that keeping chickens around the house can be profitable if certain improvements are made.

The free-range system is most suitable if you have a lot of space, preferably covered with grass. At night, the chickens can be kept in any kind of shelter, as long as it is roomy, airy and clean. This will minimise the loss of chickens to illness or theft. If you have enough space for the chickens to roam freely, a mobile chicken house is best. One example of this type of housing is shown in figure 7.

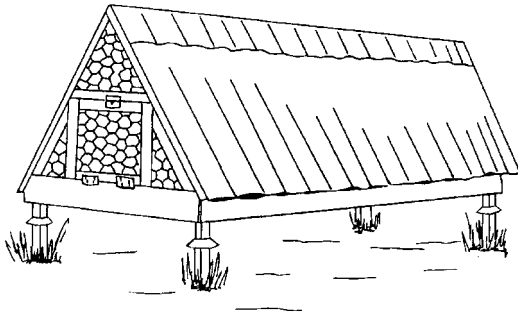

Figure 7: A simple mobile chicken house

The spread of infection by parasites in chicken faeces can be prevented by using a raised night shelter with an open floor made of chicken-wire, wooden slats or bamboo sticks 5 cm apart. This will also keep the chickens safe from predators. If you want to maximise

the number of eggs, train mature layers to use laying nests in the chicken house early in the laying period. Place the laying nests in the chicken house before the chickens start laying, and keep them in a bit longer in the morning. Remember to provide fresh drinking water.

To limit mortality among baby chicks in the free-range system, take steps to protect the mother hen and the chicks from predators, thieves and rain. Put them in a simple, separate shelter that is roomy and airy and can be closed securely. Draughts and low temperatures during the first few days are particularly dangerous for the baby chicks. Although a run is handy, it is also risky, due to possible worm infections. It is important to move the run regularly, especially in wet weather.

Fold units are very suitable mobile housing units for young chicks (figure 8 and figure 9). These cages can house 20 young hens, and contain feeders, drinkers and a perch. Obviously, you will need enough space to move the fold units around regularly.

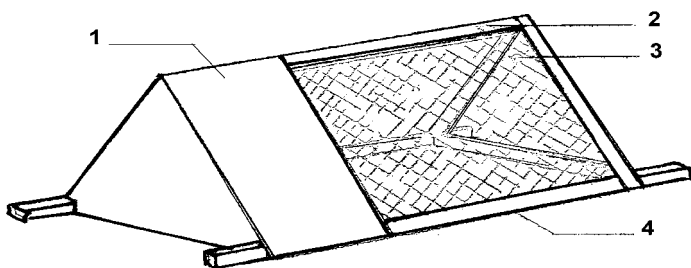

Figure 8: Fold unit for housing young chicks. 1. boarded section 2. wooden framework 3. wire mesh 4. wired floor

In areas where dogs or predators are a problem, it might be worth building a shelter well above ground level (e.g. 1.20 m high). Tin rat baffles around the supporting poles will keep out rats and other small animals (figure 10; also displayed in figure 7). The baffle must fit tightly to keep even the smallest rodent from climbing between the baffle and the pole.

Always ensure a steady supply of clean, fresh drinking water. Give your chicks extra feed, including greens which are rich in vitamins. If possible, vaccinate the chicks against the most common contagious viruses, such as Newcastle Disease. See also Chapter 7.

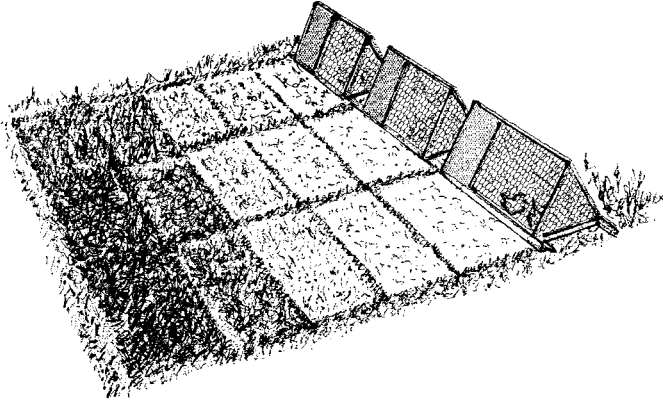

Figure 9: Systematic daily movement of fold units

Advantages of the free-range system

- Exercise in the open air keeps chickens healthy.
- Feed, even if it is not well balanced, presents few problems.
- Parasitic infections can be kept to a minimum if there is enough space.
- Little or no labour input is needed.
- The chickens help limit the amount of rubbish in a productive way.
- The direct costs of the system are low.

Disadvantages of the free-range system

- Free-range chickens are difficult to control.
- The chickens, especially young chicks, are easy prey for predators.
- Chickens may eat sown seed when looking for food.
- A large percentage of the eggs can be lost if the laying hens are not accustomed to laying nests.
- Mortality rates are usually high.

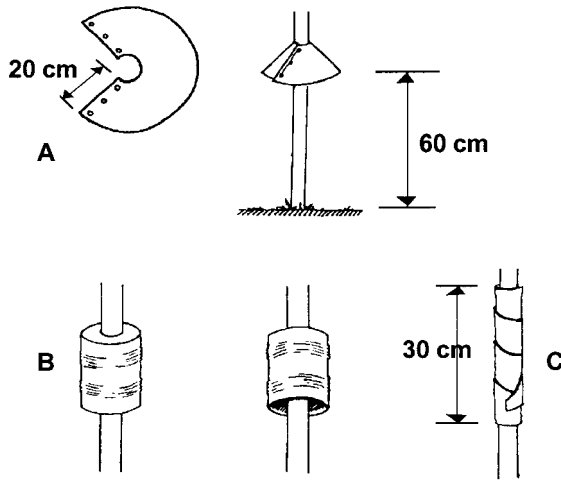

Figure 10: Examples of rat baffles. A. metal collar B. metal can upside down C. metal band around post

3.2 Small-scale housing

In both the intensive and semi-intensive production systems, housing becomes very important for improving working conditions and minimising risks. Adequate housing facilitates the feeding and egg laying and thus is a primary condition for optimal production levels.

If you decide to keep your chickens in a special poultry house, consider the following:

- You will certainly incur extra costs.
- Make sure that necessary materials are locally available.
- Should your chicken have a run? If you opt for a run, check that there is enough space to change its position regularly.
- Decide whether to continue to breed own chicken stock or to buy new stock. If you breed your own stock, you need to build more houses for separating chicks of different ages.

Optimizing climate in the house

Chickens can tolerate high temperatures but react negatively if they are too warm. Try the following as guideline when designing the poultry house.

Build the house in an east-west direction, so the chickens are less exposed to direct sunlight. Place the house where there is grass, herbs or other vegetation. Plant trees around it to keep its roof shaded. Make sure that the roof has a large overhang of 90 cm or more to limit direct sunlight and keep out the rain. Build the roof as high as possible above the floor. The chicken house will then be cooler and better ventilated.

Keep the bottom 50 cm of the side walls closed and the rest open to allow enough fresh air into the house. Close the top part of the side-walls with chicken wire or some other suitable material. A chicken house can have a corrugated metal roof, but in a sunny place, this will certainly overheat the house. In this case cover the roof with leaves or some other material. A disadvantage of this is that rodents like rats and mice can nestle in the covering. Do not keep too many chickens in the chicken house. Doing so can make the house too warm and help to spread parasitic infections. In hard-floor housing, there should be no more than 3 chickens per square meter. In houses with wire netting or slatted floors, a higher chicken density is possible.

Finally, to stimulate feeding in cooler weather, turn on a light in the house before sunrise and after sunset. This also helps to keep a steady level of egg production.

General prerequisites for a chicken house

When building a poultry house, it is not just the climate that is important. The house should also be easy to clean and to disinfect, and should therefore have a concrete floor. In permanent, closed housing, feed should always be available. A constant supply of fresh water is also essential. If the housing is to contain a large number of chickens, a separate working space in front of the house is necessary. Feed can be stored there and eggs can also be kept there temporarily. To prevent

the eggs from deteriorating, they should not be kept here longer than one week. It is best to keep the eggs in a cool place, at about 20°C. This can be done by minimising the number of windows in the storage space and only ventilating at night when the air is cooler.

3.3 Some housing options

Apart from the extensive free-range systems, there are three main types of chicken housing in extensive and semi-intensive farming:

- housing with a run
- housing with litter but without a run
- housing with slatted flooring.

In semi-intensive systems chickens are confined in a wired-in run. There is a small house attached in which chickens can be locked up at night. The owner provides most, if not all, of the feed, water and other requirements.

The main function of litter is to prevent leaching of minerals from the manure by providing organic material on which microorganisms can settle that absorb the minerals. Litter also dries the manure and gives the chicken something to scratch around in.

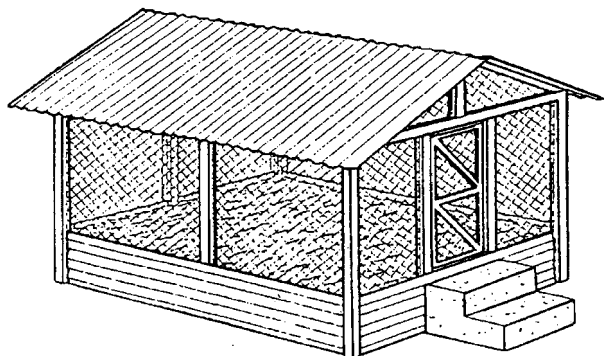

Figure 11: A deep litter house with corrugated metal and welded mesh

The number of chickens per category that you can keep is determined by the floor type: see table 1.

Table 1: Number of animals per square meter and per floor type

Floor type	Chicken category		
	broilers	layer growers 0 – 18 weeks	layers
full slats	15	9	7
2/3 slats, 1/3 litter	--	8	6
1/3 slats, 1/2 litter	--	7	5
full litter	10	6	4

Housing with a run

This type of chicken house has one or more fenced-off runs where the chickens can roam. The run is attached to the house, to which the birds have access day and night. We strongly recommend that you have more than one run so that access to the runs can be changed every two weeks. This enables grass or other vegetation to recover from the chickens' pecking and scratching, and reduces the risk of parasitic infections. Secondly, it is important that the run stays dry. The house must of course also meet the general criteria and suit the local climate.

Advantages of a limited run

- The chickens can move in the open air.
- You have more control than with free-range chickens.
- Protection against predators is better than without fencing.
- The risk of infection is smaller than with permanently closed coops.
- Housing density can be a bit higher than it can without a run.

Disadvantages of a limited run

- A limited run can get too wet and increase the risk of infection with parasites.
- It is still possible for predators to get at the chickens.

Housing with litter but without a run

Chickens stay in this type of house day and night. The floor is covered with litter to absorb the moisture of the chickens' faeces. The most

important condition for this type of housing is that the litter must remain dry. Moist litter produces too much ammonia, which damages the health of the birds. It also encourages all kinds of parasites.

To keep litter dry, use litter which absorbs moisture in its particles. Wood shavings are best but if they are not available, chopped up straw, dry leaves, wood shavings and other organic materials are also suitable. Avoid spilling water on the floor. It is best to place the drinkers on a small platform covered with slats or wire mesh. Turn the litter regularly and replace it once a week. Make sure the house is well ventilated.

Advantages of housing with litter

- There is complete control over the chickens: the feed, the eggs, etc.
- The birds are well protected against predators.

Disadvantages of housing with litter

- Litter cages are more expensive than a range or cages with a run.
- The risk of infection is higher.
- You are dependent on the amount and kind of litter that is available locally.
- You must store some litter in a dry place.

Housing with a slatted floor

In many countries with a temperate, moist climate, a large part of the floor area is covered with slats, which carry less risk of wet litter and therefore of parasitic infections. The housing density with this kind of housing can be higher, e.g. 7 birds per square meter instead of 4. The slats can be made of wood or bamboo. The space between the slats must be wide enough for the bird droppings to drop through, but they should not hamper the movement of the birds. Thin slats stay cleaner than wide slats. Slats of 1.5 cm wide and 4 cm high, laid 2.5 cm apart, give good results. These slats are generally laid in sections of 120 cm by 120 cm.

Instead of slatted floors, you can also use wire netting. This usually has a mesh of 2.5 cm by 7.5 cm, and is laid in sections of 250 cm by 200 cm. The wire should be about 3 mm thick. Perches are fixed onto the wire netting so that the birds can move comfortably and have a place to sleep at night.

To collect as much of the manure as possible under the open floors, the drinkers and feeders are best placed on the slats or wire. You can cover one third to a half of the floor with slats or wire netting. Sometimes the entire floor is covered with slats or wire but this can damage the feet of the chickens and cause loss of eggs. To make it easy to remove the manure regularly, place netting or slats at the sides of the housing.

Advantages of wire or slatted floor housing

- The chickens have less contact with their own manure, which reduces the risk of parasitic infections.
- Housing density (birds per square meter) can be increased.
- Litter costs are lower.

Disadvantages of wire or slatted floor housing

- This type of housing requires a higher investment than houses with litter.
- Cleaning the housing is more work.
- There is a higher risk that the chickens' feet will get damaged.

4 Housing equipment

All poultry housing for laying hens should have drinkers, feeders, perches and laying nests. You can also add lighting and a system to collect manure.

4.1 Feeders

Theoretically, you do not need feeders in poultry houses with runs, as the chickens find their own food. However, giving extra feed in feeders can raise production, especially at times when there is less food available outside. For all other types of housing, feeders are essential.

You will always lose a lot of feed if you scatter it on the ground. If there are only very few chickens, hand-filled feeders are the best. They can be made in different ways. Figure 12 and figure 13 show examples of rectangular wooden or bamboo feeder troughs.

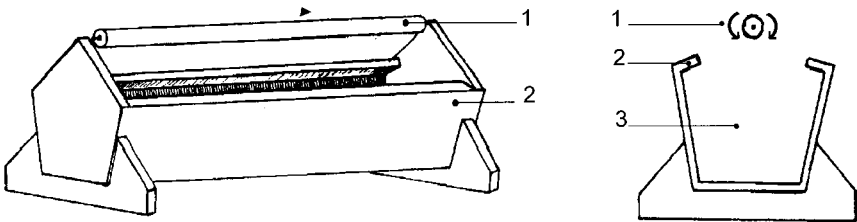

Figure 12: Through feeder on platform. 1. spinner or rotating stick
2. lip 3. trough

Some important considerations concerning feeders are the following. Make sure that there are enough feeders. With rectangular dishes or long feeders, each layer needs at least 12 cm of space along one side of a dish. See table 2.

Table 2: Space at the feeder required per bird and per feeder type

Type of feeder or dish	Chicken category		
	broiler	layer growers	layers
- long feeder	5 cm	9 cm	12 cm
- round feeder	2 cm	4 cm	5 cm

To avoid feed wastage, a feed trough should never be more than 1/3 full. Build lips around the edges of the feeders to catch spilt feed, as shown in figure 12. To reduce the amount of feed wasted, only put small amounts at a time in each feeder, and feed several times a day. This can also increase feed intake, which is often not optimal in warm climates. For this reason, it is also best not to feed at the hottest time of the day. Although chickens seem to enjoy moist feed, it is better not to give it to them in tropical climates, as it spoils quickly.

Place a rotating stick (as in figure 12) above the feeder to prevent the birds from sitting in the feeder and dirtying the feed. Spread the feeders around the poultry house, no more than 5 m apart, so that it is easy for the birds to find a dish.

In housing with wire or slatted floors, most, if not all, feeders should be placed on the wiring or slats.

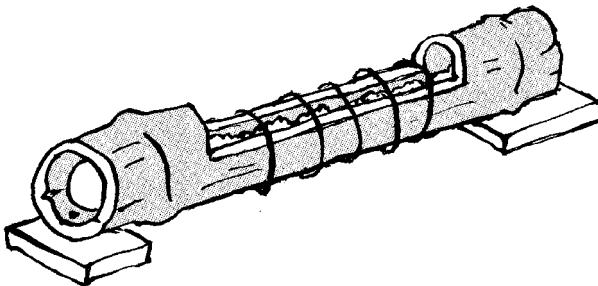

Figure 13: Bamboo feeder with wire wrap and wood brace to prevent tipping

If there are many chickens, you can install storage containers which have extra storage space so that daily feeding is no longer necessary. An example of a rectangular wooden container is shown in figure 14.

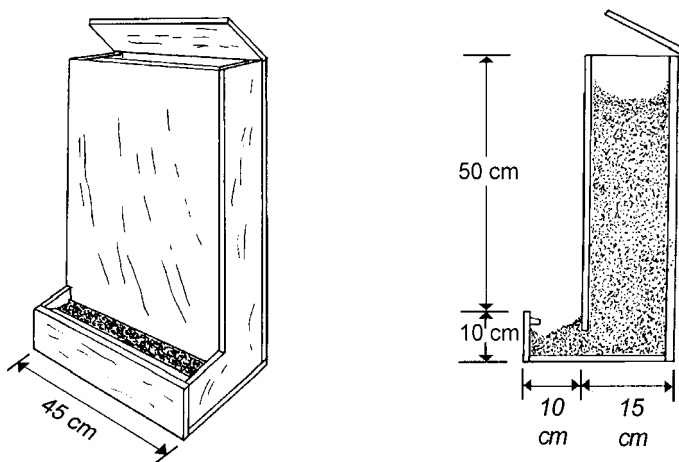

Figure 14: Rectangular wooden feeder

Hanging feeders are also sometimes used: see figure 15.

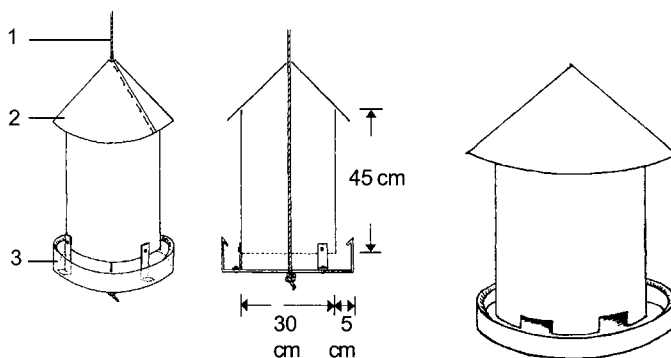

Figure 15: Hanging metal feeder. 1. hanging wire 2. sheet metal cone 3. sheet metal tray

4.2 Drinkers

In tropical areas it is *very* important to supply chickens with enough water that is cool, clean and fresh. There are a number of ways to do this. For small numbers of chickens, an upside-down bottle, as shown in figure 16, is a cheap and easy solution. You can add a strap of leather or tin to fix it to a wall or board.

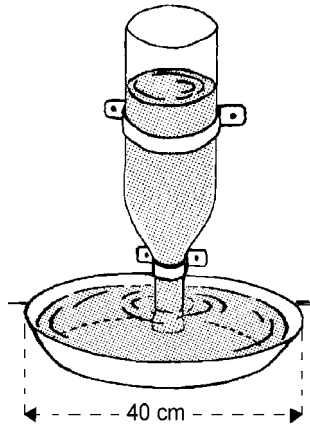

Figure 16: Water bottle put upside-down into open container

Another possibility is to buy simple round metal or plastic bowls. The advantages of a drinker with a reservoir are that water is available for longer and it is less likely to get dirty.

When installing drinkers, make sure that water is always available. The water should be clean and as cool as possible. Clean the drinkers daily. Make sure there is enough drinking space available (table 3). A metal feeder with tray of 40 cm in diameter is sufficient for 10 mature layers

Table 3: Space at the drinker needed per bird for several types of drinkers

Type of drinker	Chicken category		
	broilers	layer growers	layers
- Long drinker	2 cm	2 cm	2 cm
- Round drinker	1 cm	1 cm	1 cm

In litter cages, place the drinkers on a small platform of chicken wire to prevent spilt water from wetting the litter. If no platform is installed, the drinkers must be moved to a new spot every day. In all other types of housing, it is best to place the drinkers on wire or slats.

Drinkers need to be placed at different places in the poultry house but should not be further apart than 3 to 5 m.

4.3 Perches

Chickens like to spend the night on high perches as shown in figure 17 and in figure 37. The more nervous birds can also quickly find shelter there during the day. You will need a space under the perches to catch the bird droppings. Like this, the litter will not get so moist and it is also easier to collect it.

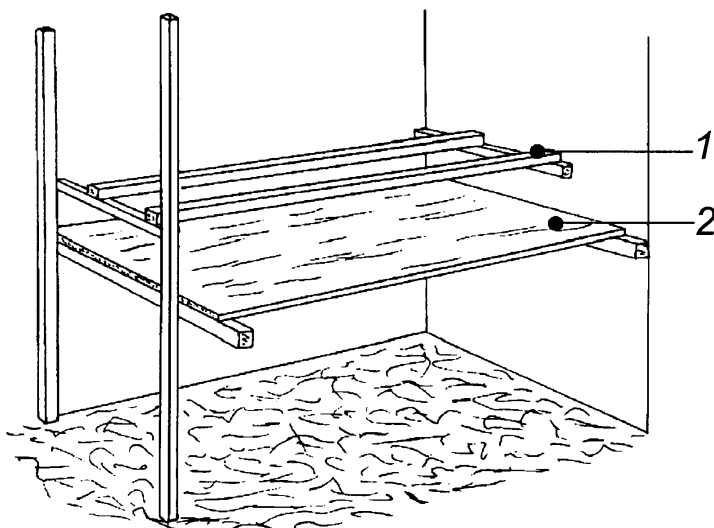

Figure 17: Perch (1) with dropping board (2)

Perches are small slats 5 cm wide and 35 cm long, usually made of wood. It is best to place them about 5-7 cm apart. Each chicken needs approximately 15 cm (or more) of sitting space, depending on its size. Although perches are indispensable in all kinds of chicken houses, they can vary in kind and in location.

In housing with litter, it is a good idea to place a wooden board under the perch to catch most of the droppings. The dropping board must be cleaned daily, and the manure removed regularly, preferably once a week. Usually this board is installed about 75 to 80 cm above the ground, with the perches placed 1m above the ground. To prevent the chickens from coming into contact with their droppings, close the gap between the board and the perch at the front.

In cages with wooden slats, perches are not necessary. However, they should be installed if the floor is made of chicken-wire, to enable the chickens to spread out evenly over the wire floor at night.

4.4 Laying nests

Hens usually prefer to lay eggs in protected nests, rather than simply on the floor of the house. There are two types of nests: individual and communal laying nests. In this section, we will discuss both communal and individual laying nests. Both types will be discussed in this section. In all poultry houses except battery cages, eggs are collected by hand.

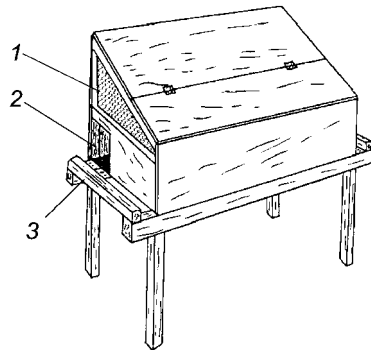

Figure 18: Communal laying nest: 1. wire netting 2. side entrance hole 3. perches

It is best to install a sloping cover over the nest box to prevent chickens from sitting on the nests and making them dirty.

Laying nests are usually placed above the ground at 0.6 to 1 m height. Place a jumping perch in front of the nests. To keep the litter in the nest, make a small retaining board of 10-15 cm height at the front of the nests. During the night close the nests with boards.

Communal laying nests

Figure 18, figure 19 and figure 20 show communal laying nests.

Communal nests which can be used by up to 10 hens at the same time are not very suitable for tropical conditions because hens may get too hot in them. It is essential to add wire netting or an open front and back to provide the necessary ventilation.

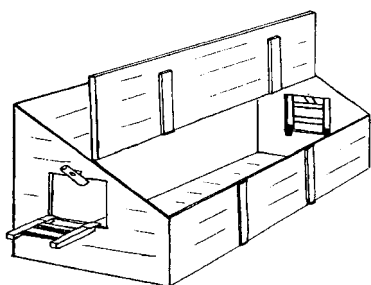
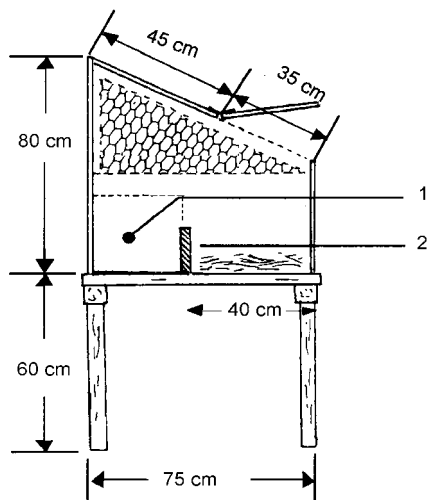

Figure 19: Communal laying nest with open board



*Figure 20: Communal laying nest
1. entrance 2. retaining board*

Individual laying nests

Individual nests can be grouped in blocks along one or more walls of the chicken house (see figure 21 and figure 22). In open housing, however, we recommend placing the nests along the width of the house, out of any draughts.

Individual nests should be about 30 cm deep, 35 cm long and 40 cm high. They can be made of wood or other locally available materials, such as bamboo or hard types of grass. They should be filled with a thick layer of litter to prevent eggs breaking.

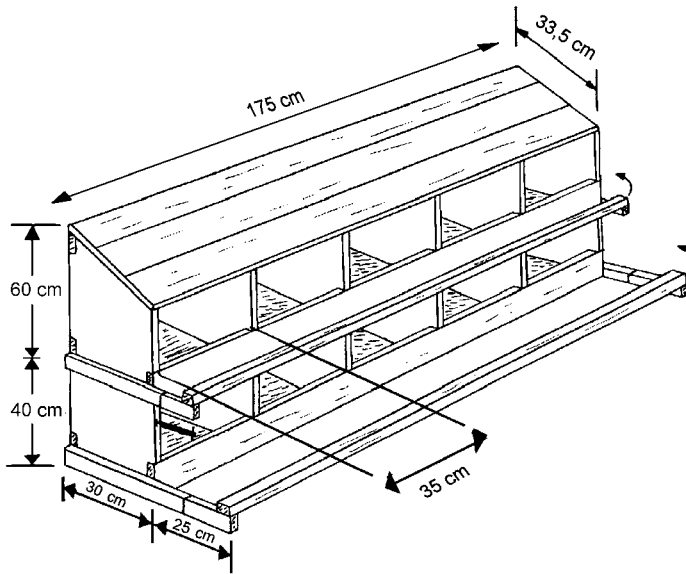

Figure 21: Grouped individual laying nests

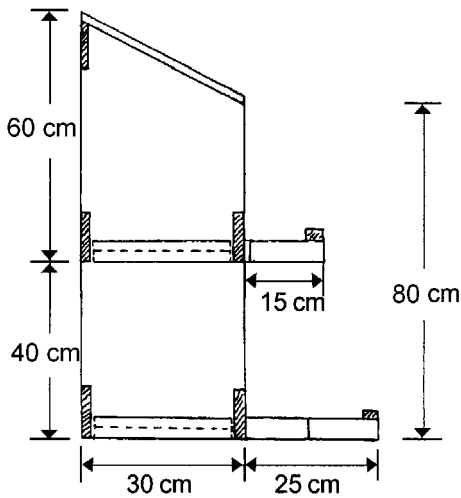

Figure 22: Cross-section of individual laying nests

Floor eggs

Floor eggs are often a big problem in litter housing and housing with slatted or wire floors. Those eggs are usually dirty and require extra work. During the first weeks of the laying period, the percentage of floor eggs will reach a maximum of 5-10%, after which it should quickly decrease to 1 or 2% at the most.

The following measures will help limit the number of floor eggs. Place at least one laying nest per five laying hens. Place the nests in time: at least 2 to 4 weeks before the laying period in the poultry houses starts. Collect the floor eggs several times a day at the beginning of the laying period to discourage hens from continuing to lay them. Try to disturb the roosting hens as little as possible in the morning. Later in the day, the eggs should be collected as often as possible to prevent them from breaking.

Keep the nests as dark and cool as possible. Maintain a thick and comfortable layer of litter in the nests. Make sure the nests can be reached easily. Remember to install jumping perches. A split bamboo support can hold a nest and thus keep brooding hens safe. This is a light and mobile laying nest which is easily replaced and is out of reach of dogs and other predators.

A roll-away nest with a sloping floor is shown in figure 23. This is a very convenient method for collecting eggs quickly. This is, however, not a suitable nest box in semi-intensive chicken keeping as it is inconvenient for chicken to stay at night.

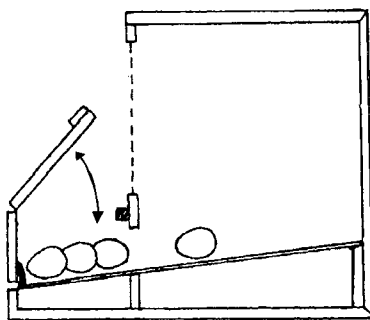

Figure 23: Cross-section of roll-away nest

Lighting

There are two ways to try to raise the production of chickens by using artificial lighting.

- If the housing is lit in the cooler hours before sunrise or after sunset, the chickens are able to eat more.
- If the day length is increased by using artificial lighting, laying hens are encouraged to lay more eggs.

Day length must not be increased until just before young chicks start laying. Otherwise, it can lead to premature laying maturity. It is best to start raising the chicks when the days are getting shorter. If you need to start the growing period when the days are getting longer, try to artificially ensure a constant day length. Just before the laying period starts, lengthen the days by one hour a week until you have 14 hours of light per day. After production rates have reached a maximum, lengthen the amount of light per day by one hour a week until there are 16 hours of light.

Once day length has been increased from 12 to 14 hours, you will need to provide artificial light after sunset to maintain the extra day length. If you do not do so, egg production will decrease. If you are raising laying hens when the days are getting longer, you do not have to provide extra light to stimulate egg production. However, the hens will probably eat more if the housing is lit during the cooler periods of the day.

Whichever kind of light you install, it must be strong enough. If you use oil lamps, there must be enough of them, and they should be located in the centre of the chicken house, and should be screened off with thin slats or wire gauze, even if they are hung up. If you have electricity, a chicken house can be lit with ordinary light bulbs. 40 Watt bulbs should be placed 3 m apart and 60 Watt bulbs about 5 m apart.

5 Nutrition

This chapter describes nutritional requirements, feeding methods and feed composition. Also water is treated as a nutrient, since it is necessary for life. The nutritional requirements of chickens are shown in figure 24 and table 4.

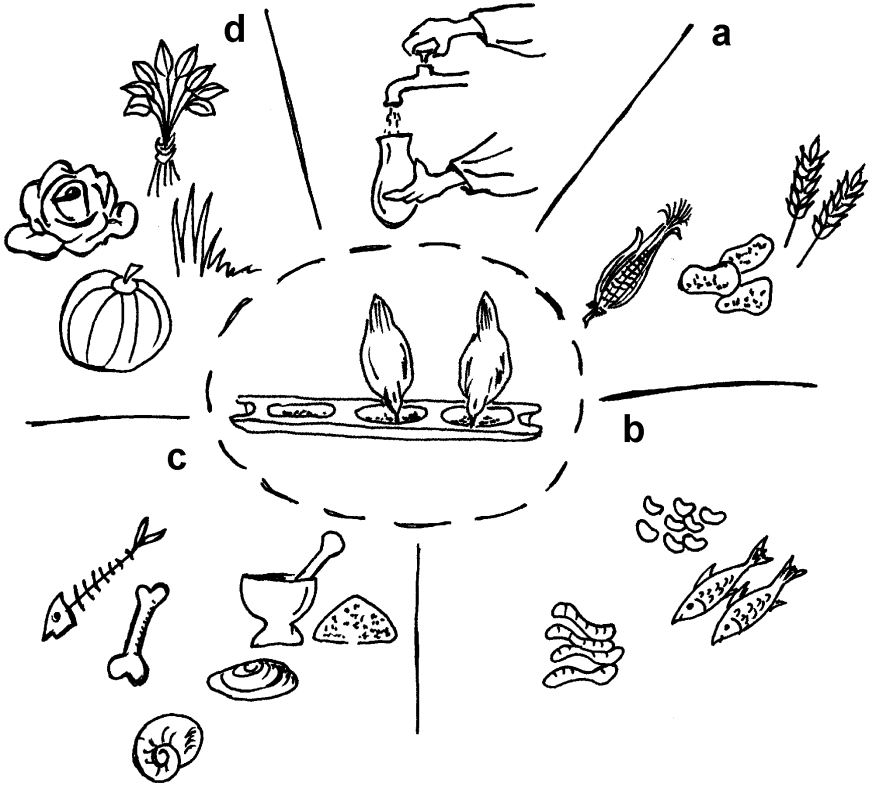

Figure 24: Feeds and nutrients (Poultry Network)

Table 4: Essential nutrients in a poultry diet

Letter in Figure 24	Nutrient category	Possible nutrient source
Top	water	rainwater, tap water, spring water
a	energy	starch from grains or tubers, fat from seeds
b	protein	(soy)beans, fish, insects
d	vitamins	fruit, green vegetables, animal products
c	minerals	bone-ash, shells, limestone

5.1 Water

The body of a bird is made up of 70% water and eggs are approximately 65% water. Poultry must have a continuous supply of clean fresh water so that nutrients can be absorbed and toxic materials removed from the body. This is especially vital for young chicks. A lack of water will reduce feed intake, seriously retarding growth and impairing egg production. This is particularly true in hot climates, where deprivation can rapidly lead to death.

Water is also essential for birds to control their body temperatures in hot weather. Birds need a lot more water at high temperatures than at low temperatures, and lack of water quickly leads to death by overheating.

It is undesirable to restrict any bird's water intake, particularly in the tropics. Even a 10% restriction in the amount of water available can reduce the growth rate and feed conversion efficiency (amount of feed needed per kg growth) of broilers. With layers, the effect is even more devastating. Short periods of deprivation can result in moulting and the cessation of egg production.

5.2 Energy requirements

The energy intake means the calories that are taken in by the chicken with its feed: see figure 25 for a schematic design. The amount of *energy contained in feedstuffs* is normally expressed in units of metabolisable energy (ME) per unit weight. The *metabolisable energy* refers

to the feed energy that is available to the bird for maintenance of vital functions and the production of meat and eggs. It is expressed in e.g. calories per gram (cal/g) or kilocalories per kg (kcal/kg). 1 kcal equals 4,2 kJ. The energy *requirement* of poultry can be expressed in terms of metabolisable energy per day (kcal/d).

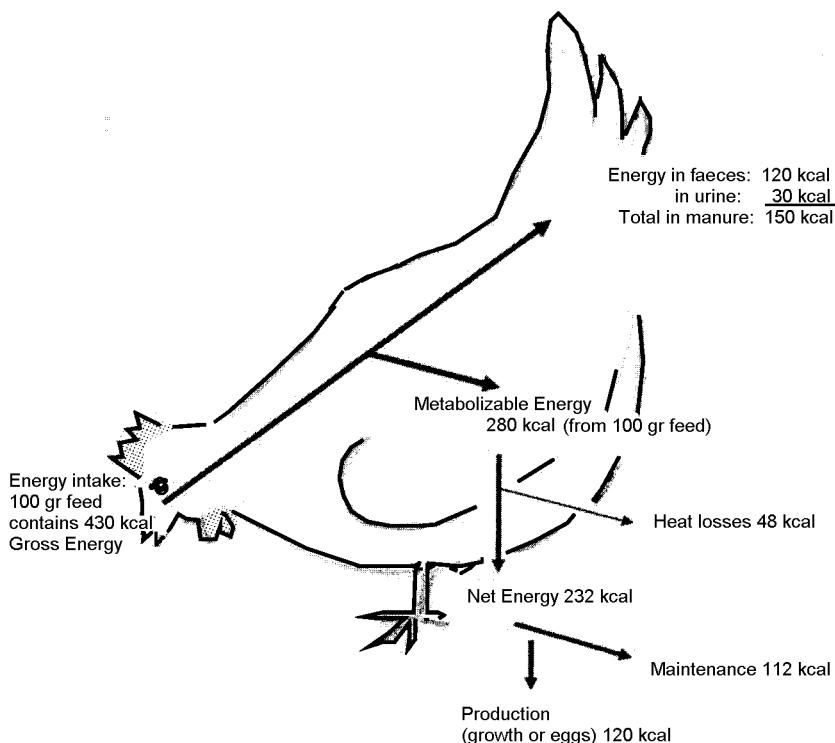

Figure 25: Example of daily energy intake, losses and utilisation by a chicken (PTC⁺)

Dietary energy comes mainly from carbohydrates but also from fat and protein. Chickens are usually given free access to food and allowed to consume as much as they wish. They usually consume just enough food to meet their nutrient requirements. This control of intake is based primarily on the amount of energy in the diet.

Birds eat to satisfy their energy requirements. Thus, increasing the concentration of energy in the diet will result in a decrease in intake, and vice versa, as long as intake is not limited by problems of bulk, texture, inaccessibility or palatability. Levels of nutrients in a diet are therefore often stated in terms of energy content. Recommended energy levels in poultry diets are about 2,800 kcal/kg for layers and about 3,000 kcal/kg for broilers (see appendix 2). When chickens reduce their intake because of heat stress, it is advisable to use more concentrated diets, so that they get enough nutrients in spite of the lower intake.

5.3 Protein requirements

Protein is made up of amino acids, and birds obtain these amino acids from their feed to build up their own proteins in the body. See table 5.

Table 5: Classification of amino acids

Essential	Difficult to classify	Non-essential
phenylalanine * methionine lysine threonine tryptophan isoleucine leucin evaline histidine arginine	tyrosine cysteine ** glycine serine proline	alanine aspartic acid glutamine
* phenylalanine be converted <u>to</u> tyrosine ** cysteine can be converted <u>to</u> methionine		

Priority always goes to maintenance, and any surplus is used for growth or egg production. High protein feed is expensive, so rations which are too high in protein are wasteful. The excess protein is broken down and used as an energy source, and the excess nitrogen is excreted as uric acid. The synthesis of protein in the body tissues requires an adequate supply of about twenty different amino acids in the proper proportions. Ten of these cannot be synthesized by the bird's metabolism and must therefore be supplied by the diet. These are

called essential amino acids, the main ones being lysine and methionine. A shortage of essential amino acids will limit production.

The quality of feed protein can be described in terms of the amino acids it supplies. However, it is useful to specify total requirements for crude protein in addition to requirements for the main essential amino acids. There should be enough crude protein to supply the required amounts of these amino acids. In most nutrient requirement tables, only the percentages of lysine and methionine are given, and these percentages should be regarded as an indication that there is enough of the other essential amino acids too.

5.4 Vitamin requirements

Vitamins play a role in the enzyme systems and natural resistance of poultry. See Appendix 2, table 17. They are only needed in very small quantities, but are vital to sustain life. Vitamin deficiency can lead to serious disorders. Natural vitamins are found in young and green plants, seeds and insects. When birds are confined in poultry houses, they are entirely dependent on the vitamins present in the compounded feed. All vitamins may be purchased in a synthetic form at a commercial price, and may be added to the mixed feed as a premix. Without extra vitamins, rations may not be balanced enough to support high productivity.

5.5 Mineral requirements

Minerals, especially calcium (Ca) and phosphorus (P), are chiefly needed for the bones. Enzyme systems are also often dependant on trace elements of certain minerals, such as iron, copper, zinc and iodine. These other essential minerals are also described in Appendix 2, table 18.

The mineral requirements of poultry are defined in terms of the separate mineral elements, although minerals are always added to diets in the form of compounds. It is useful to know the proportion of each

element in these compounds, so that the correct amount of this element can be added to the diet. See table 6.

Table 6: Percentage of the elements in mineral compounds

Compound	Chemical formula	% of element in compound
Limestone flour Calcium carbonate	CaCO ₃	40% Ca
Zinc carbonate	ZnCO ₃	52% Zn
Anhydrous iron oxide	Fe ₂ O ₃	70% Fe
Manganese sulphate	MnSO ₄	36% Mn
Copper sulphate	CuSO ₄	16% Cu

Calcium and phosphorus

Calcium and phosphorus both primarily add to the structure and maintenance of the chicken bones. The skeleton accounts for about 99% of the calcium and 80% of the phosphorus in the body. The two minerals interact with each other, both before and after their absorption from the digestive tract. An over-supply of either mineral can interfere with the utilization of the other.

During egg production, calcium needs are more than doubled. Poultry's calcium and phosphorus requirements are influenced by the amount of vitamin D in the diet, increasing as the level of vitamin D decreases and vice versa. For growing birds, the ratio of Ca : P should be between 1:1 and 2:1. However, laying birds need a ratio of up to 6:1, and they need about 4.0 g of calcium per day for eggshell formation.

Supplements like steamed bone-meal are added to chick and grower diets to provide extra calcium and phosphorus. For laying birds, the extra calcium requirement is provided by oyster-shell grit fed separately or by limestone flour added to the diet. The main criteria for determining a laying hen's requirements of calcium and phosphorus are egg production and shell thickness.

Calcium requirements should be specified in terms of amount of calcium per day rather than percentage in diets. This is particularly im-

portant in the tropics, where reduced intake due to heat may result in too little calcium being consumed each day.

5.6 Other ingredients in chicken diets

So far, we have considered the energy, amino acid, vitamin and mineral content of chicken diets. Vitamins and minerals can be added as premixes to the diets of laying hens and broilers. Other ingredients to be considered include coccidiostats as preventive medicine and antioxidants as preservative.

A prophylactic dose of a coccidiostat should be added to every broiler diet, following the manufacturer's directions. The dose can be withdrawn towards the end of the fattening period. As coccidiosis may occur in flocks treated with a coccidiostat at prophylactic levels, it is advisable to have a concentrated coccidiostat available for medicating the water at a curative level.

Commercial feed preparations may also contain an antioxidant, especially when there is additional fat in the feed mix.

6 Feeding methods

This chapter discusses consequences of the housing system for feeding choices. It helps stepwise to rationally calculate diets for various purposes and with a range of different feed ingredients.

6.1 Feeding in various housing systems

Free-range chickens

If you have scavenging chickens, you can do little to influence what they eat, but certainly trust that they will eat what they need. On the other hand chickens can only have a good diet if they can find all the nutrients they need. In many free-range situations, chickens will certainly not be able to find everything they need all year round.

During harvest time or other periods when they can get a lot of grain, chickens will usually get enough energy. However, at such times they usually get too little protein to grow and lay as well as possible. It is important that chickens then get extra protein. This can be animal protein, such as worms and snails, or protein-rich supplements such as soybean oil-cake, fish-meal, etc. In dry periods, a vitamin deficiency can quickly develop. Adding some green vegetables to the chicken's diet will provide them with some of the minerals and vitamins they need.

Housed chickens

Chickens kept in a poultry house must be provided with all the food they need by the chicken raiser. If the chickens have a limited run, they can find some of the minerals and vitamins they need themselves, as long as there is enough vegetation in the run. It must also be shifted regularly, e.g. every two weeks, to reduce the risk of infection with parasites.

For commercial production, there are different types of chicken feeds for the different age categories. In general, two kinds of feed are used

for the rearing period from 0 to 18 weeks, when the chick matures until it can start laying: a high quality starter feed for very young chicks (up to 6 weeks) and a growers feed for chickens from 6 to 18 weeks. During the laying period, only one kind of chicken feed is usually available for laying hens, but it is possible to use a pre-layer feed for some weeks. The most important ingredient is the calcium to produce good egg shells. If the feed contains less than 3% Ca, extra grit or shells must be given to the layers.

Commercial broilers can grow very fast (1.5 – 2 kg in 6 weeks), but only under good management and with special, highly concentrated broiler feed. They can be given the same feed as the growing chicks of layers, but then they grow more slowly. Generally, broilers receive ‘starter feed’ for the first 2 weeks only, and then ‘finisher feed’, which is higher in energy but a bit lower in protein. Since young broilers are very sensitive to coccidiosis, an intestinal parasite, a preventive dose of coccidiostat should be added to their feed. A few days before slaughtering, this medicine should be withdrawn from the feed, to make sure there are no residues in the broiler meat.

6.2 Feed intake

Feed can only be stored for a short time. If it is kept too long, its quality will decrease, especially the vitamin content. Be sure to buy fresh feed. If you have to store it, try to do so in a dry and, if possible, a cool place. Keep it out of reach of rats, cockroaches, etc. You should not store the feed for more than a few weeks.

It is strongly advisable to check how much feed is consumed by the chickens, as far as possible. Any deviation from the normal feed intake might indicate a change in production level and/or health status.

The voluntary feed intake is the amount of feed that a bird consumes when it has unlimited access to a diet. Monitoring of the intake is important because, if a flock consumes less than expected, production will be lower than expected too, and the birds may lack certain nutri-

ents. Also, a reduction in feed intake can be a useful warning of management errors like insufficient drinking water, or of an outbreak of disease. If the intake is above the predicted level, certain types of birds may be growing too fat, or, more likely, there might be spillage of feed or losses to rodents.

The most important factors affecting food intake are the following:

- body weight
- growth rate
- egg production
- feed quality
- environmental situation

Body weight

Heavy birds consume more food than light birds. To maintain the body and all its basic functions, the average feed requirement is 70 grams per day for a body weight of 2 kg. For every 50 grams above 2 kg, one extra gram is needed, and for every 50 grams less than 2 kg, one gram less is needed.

Growth rate

Growth rate is the rate of live weight gain. Growing birds require extra feed. For every gram of weight gain, they need roughly 1.5 grams of feed, above what they need for maintenance. Faster growth means better food conversion, especially for broilers, because it makes more of the feed available for production. At a given weight, immature birds of broiler strains have a much higher feed intake capacity than birds of an egg laying strain.

Egg production

Laying hens' intake of dietary energy is related to their egg production rate. If egg production increases, more feed is needed. Generally, for every gram of egg produced, one more gram of feed is required, above maintenance intake level. This is calculated by multiplying the laying percentage by the average egg weight.

Feed quality

The major dietary factor affecting feed intake is the concentration of energy in the diet. An increase in dietary energy results in a decrease in feed intake. The concentration of nutrients other than energy does not influence appetite, as long as it remains within the range for normal health and production.

The standard energy level for layers is 2,800 kcal per kg of feed (see appendix 2).

The intake of pelleted feed can be up to 8% more than the intake of the same feed in the form of meal. This is partly because pellets are partially cooked, and partly because they are easier to eat. In young birds, this high intake is desirable since it boosts the growth rate, but in adults it can lead to over-consumption and obesity.

Environmental situation

The main issue is how the birds are kept. In a cage, birds move much less and therefore need less energy, and this will save 5 grams of feed per bird per day.

Secondly, temperature has a big influence on feed intake. Low temperatures stimulate the feed intake, but it is more of an issue that high temperatures ($> 28^{\circ}\text{C}$) limit the voluntary feed intake. In hot climates it is hard for the birds to eat enough to maintain high production. Ventilation and cooling should help, but another solution is to offer more concentrated feed.

Light intensity and day-length have some effect on voluntary feed intake. With laying birds, this is due to the effect of day-length on egg production. Longer days stimulate egg production and therefore encourage hens to consume more feed. With chicks, light has a more direct effect upon feed intake by regulating behaviour patterns and extending activity and feed consumption. Maximum feed intake and growth rate are obtained when chicks are reared in continuous light. With broilers, however, too many hours of light (>20 hours) may in-

crease activity and therefore reduce the efficiency of feed utilization, because extra activity requires extra feed. For this reason, intermittent light schemes have been developed for intensive production systems.

6.3 Restriction of energy intake

Restricting energy intake has a different effect on pullets of egg producing strains than on those of meat producing strains.

Pullets of egg producing strains

It is not usual to restrict the food intake of growing pullets being reared for egg production. Nor is it usual to restrict their food intake during the laying period, because optimal physical development is necessary for good egg production.

Pullets of meat producing strains

Pullets of heavier stock (broiler parent stock) are not normally allowed unlimited access to feed during the growing stage. Their feed intake is restricted in order to reduce live weight gain, and in particular to limit the amount of body fat at the onset of egg production. The degree of restriction depends on the breed. Various methods of restricting feed intake can be used. These include skip-a-day feeding, low protein diets, high fibre diets and low lysine diets.

Skip-a-day feeding is probably the easiest. With this system, if birds are to be rationed to 70% of their voluntary intake, they are fed 140% of their daily intake once every two days. This technique ensures that every bird, including those low down the pecking order, is able to obtain its fair share of food. If birds are given 70% of their food intake every day, birds high up in the pecking order will achieve 100% of their desired consumption, whereas birds lower down the pecking order may consume less than 50%.

Birds of modern broiler strains must be even more severely restricted (to less than 50% of what they would naturally eat), if they are to pro-

duce enough eggs. The best advice for any farmer keeping modern broiler strains is to follow the chick supplier's advice.

6.4 Feed composition

Although poultry farmers don't decide what is put in the chicken-feed they buy, they can check that it contains all the nutrients the chickens need in the right proportions. An overview summary of the nutrient requirements is given in the tables in Appendix 2.

Food represents 60-70% of the cost of producing chicken meat or eggs. So savings on feed can help a lot to keep your production costs down. It is therefore important to use the cheapest suitable food in the correct ratio, and to know what feedstuffs are available and how they should be used.

We discussed the essential nutrient sources in Chapter 5. For purposes of diet and ration calculation, we classify feedstuffs for poultry diets into five broad classes:

- cereals or cereal by-products, mainly for starch and protein
- other energy feed like roots or oils
- protein-rich vegetable feeds
- animal proteins
- mineral supplements.

Pearson square

Chicken diets can be calculated by designing a so-called Pearson square (figure 26).

Table 7 shows the calculation of a diet for a laying hen, using 4 different feedstuffs to create a mixture containing 16.5% protein. The various feedstuffs are put into two groups: high protein and low protein. Within the group they can replace each other, so the price will decide which one will be used more. Then the averages for each group can be calculated according to the amounts of each ingredient used.

Table 7: Calculation of a diet for a layer, regarding protein

Feedstuff	Content of crude protein (%)
Maize	8
Sorghum	10
Soy bean meal	44
Fish meal	65

Suppose maize is cheaper and more plentiful than sorghum, and soy-bean meal is cheaper than fish meal. Including all 4 ingredients makes the feed more reliable, as the ingredients complement each other. 5 – 8 ingredients in a mixed feed may be optimal.

In our example, you can make a cereal mix with two parts of maize (8% crude protein) and one part of sorghum (10% crude protein) from one group, to be combined with a protein-rich mix of 3 parts of soy bean meal (44% crude protein) and one part of fish meal (65% crude protein):

Cereals - weighted mean:

* maize	2 x 8% =	16%	
* sorghum	1 x 10% =	<u>10%</u>	
<u>Weighted mean for the cereals</u>		26%	/ 3 = 8.7% protein

Protein feeds - weighted mean:

* soy bean meal	3 x 44% =	132%	
* fish meal	1 x 65% =	<u>65%</u>	
<u>Weighted mean for protein feed</u>		197 %	/ 4 = 49.3% protein

The weighted means of the cereals and the protein feeds must be put on the left-hand side of the Pearson square, in order to find which combination of the two will result in the required 16.5% of protein.

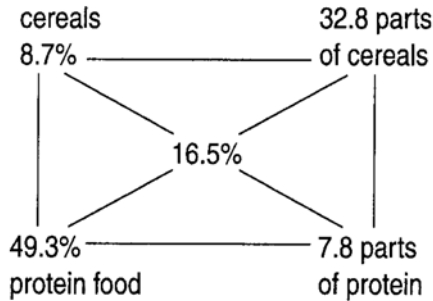

Figure 26: Pearson square

The protein level required in the complete diet is placed in the middle of the square and the percentage of protein content in each food on the two left-hand corners of the square. To work out the proportion of each foodstuff that is required, subtract the small number from the larger one diagonally across the square, as shown below.

The resulting figures on the right-hand side of the square indicate the proportion of each mixture needed to achieve a diet containing 16.5% protein. In this case, this requires a ratio of 32.8 parts of the cereal mix to 7.8 parts of the protein feeds (3 soybean meal : 1 fishmeal).

Expressed in percentages of the total mixture, the diet will be made up as follows:

$$\frac{32.8}{32.8 + 7.8} \times 100\% = 81\% \quad \text{cereals}$$

$$\frac{7.8}{32.8 + 7.8} \times 100\% = 19\% \quad \text{protein mix}$$

The cereals feed consists of sorghum and maize in the ratio 1 : 2

$$\frac{81\%}{3} = 27\% \text{ of sorghum } (\frac{1}{3}), \text{ and } 54\% \text{ of maize } (\frac{2}{3}).$$

For the protein mix, the same procedure is used to divide the 19 % in the ratio 1: 3

$$\frac{19\%}{4} = 5\% \text{ of fish meal } (\frac{1}{4}), \text{ and } 14\% \text{ of soybean meal } (\frac{3}{4}).$$

With this combination of the 4 feed ingredients, we can now calculate whether this diet will meet the other nutrient requirements as well: see table 8.

Table 8: Calculation of the nutritive value of a diet

Feedstuff	Part of this feed mixture (%)	Energy (kcal/kg)	Protein (%)	Crude fibre (%)	Calcium (%)
Maize	54	1,804	4.8	1.1	0.02
Sorghum	27	886	2.7	0.5	0.01
Soybean meal	14	350	6.2	0.9	0.04
Fish meal	5	165	3.2	0.0	0.25
Total	100	3,205	16.9	2.5	0.32

The energy content of 3,205 kcal/kg exceeds the minimum of 2,800, the protein level is good and the crude fibre does not exceed 7%. Only the percentage of calcium is far to low for layers. It should be between 2.5 and 3.5 %. You have to add some limestone and bone-meal to supply about 4.0 g calcium per day and to meet the calcium and phosphorus requirements (in a ratio of 6 :1). Alternatively, grit or broken shells can be given separately from the feed, for voluntary intake. See table 22 in Appendix 2.

The proportion of the different ingredients in the ration is more important than the quantity you supply. Poultry will not eat any more once their energy requirement has been met.

7 Health care

For good productivity and profitability, you should keep your chickens as healthy as possible. Sick chickens do not produce, and profits will be lost if you have to buy medicines or if your chickens die. Prevention is better than cure, so try to provide good housing, nutrition and health care for your chickens, and observe them daily for any abnormalities and disease symptoms. Some diseases can spread rapidly through a poultry flock so sick-looking birds should be housed separately and given extra care. Contact your veterinary or extension agent for information about common poultry diseases in your area and the availability of chicken vaccines.

7.1 Infectious diseases and their causes

Disease can occur in poultry of all ages and breeds. When birds look sick and/or behave strangely (see figure 27) there are many possible causes. A healthy chicken is active, has bright eyes and scavenges for food. Unhealthy or sick birds are often less active, with dull eyes and ruffled feathers. Sometimes you may observe abnormal breathing (coughing, swollen eyes), abnormal digestion (watery or bloody diarrhoea, dirty feathers) or locomotion disorders (paralysis/limping).

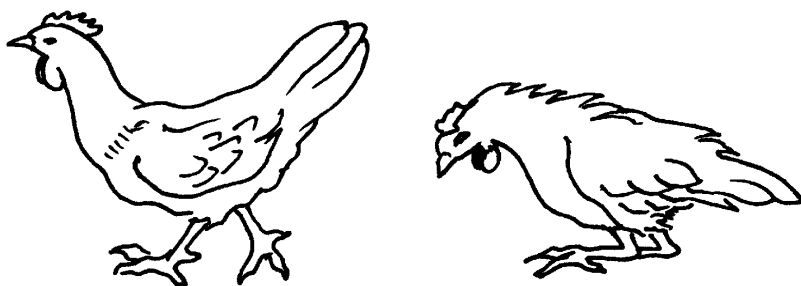

Figure 27: Healthy and unhealthy chicken (Poultry Network)

Sometimes you may notice that hens are laying fewer or abnormal eggs. Some diseases can cause high mortality rates (figure 28).

Causes

Infections are caused by germs. These microbes act as pathogens, which means that they cause disease:

- ▶ viruses causing e.g. Newcastle Disease, bird flu or avian influenza, fowl pox and Gumboro disease
- ▶ bacteria causing e.g. fowl cholera, typhoid and pullorum disease
- ▶ fungi causing e.g. Aspergillosis or brooder pneumonia.



Figure 28: Some diseases can cause high mortality rates

Of all the microbes, only a few parasites are visible to the naked eye. All other germs can only be seen with special microscopes. Fungi or moulds can produce toxic substances called mycotoxins. If birds eat feed with mycotoxins, their resistance may be lowered. Feed should therefore be stored properly to avoid fungal growth. Parasites also cause disease or growth retardation: internally (roundworms, tapeworms and coccidiosis) or externally (fleas, ticks, lice).

Diagnosis

Generally speaking, making the right diagnosis is the work of a veterinarian. Always keep in touch with a vet, if possible via a veterinary assistant or a community or village animal health worker.

We do not intend to describe diseases in this chapter. For symptoms, causes, treatment and vaccination of the most common diseases, we

refer to the table in Appendix 1: Infectious diseases. However, this is just an overview: in case of doubt about a disease among poultry, it can never replace professional diagnosis and advice by a veterinarian! We also draw your attention to the Agrodok *Poultry health* (forthcoming).

Spread of infectious diseases

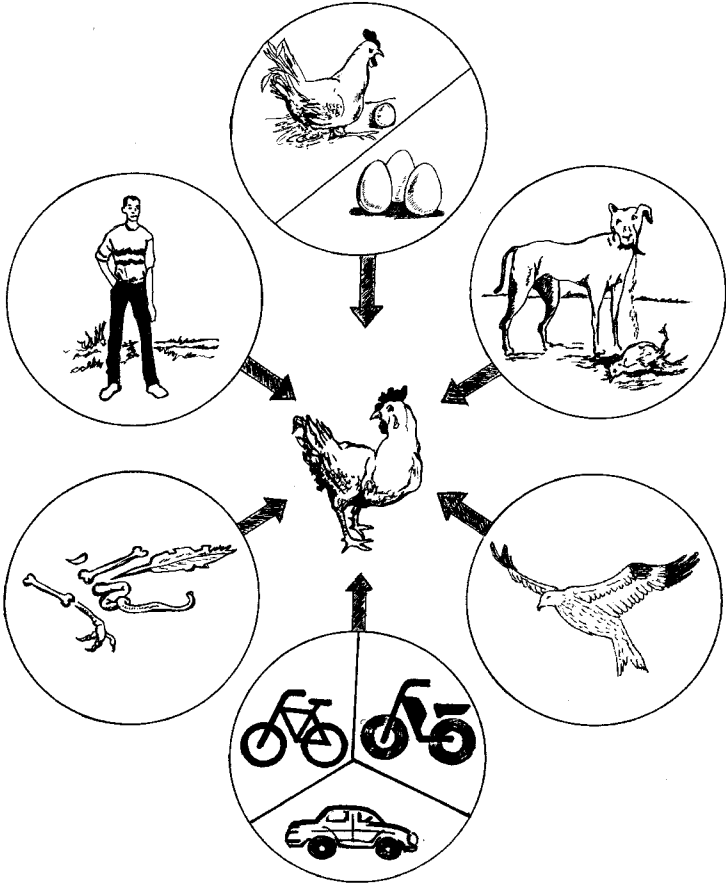

Figure 29: Ways of spreading infectious pathogens (based on ACIAR)

Pathogens can multiply rapidly in a chicken flock and be passed from bird to bird via a range of ways: see figure 29. They can pass from bird to bird via saliva, droppings or contaminated eggs. They can also be spread via humans and animals (rats, birds, flies), on boots, feed bags, equipment, bicycle- or car tyres. Some viruses can even be spread by air, on wind and dust. Other birds (ducks, geese, turkeys, guinea fowl) can carry pathogens without showing any signs of disease, and can pass them on to chickens. The most notorious case of this is avian influenza.

Older and more resistant birds can also carry pathogens and can contaminate younger and weaker ones. Live markets provide ideal opportunities for spreading many microbes.

Bringing home live birds from a market *could* turn out fatal for your poultry flock. Therefore, keep newly acquired animals separated in quarantine (see figure 30), observing their behaviour and watching out for signs of disease.

Some poultry pathogens can cause disease and death in humans as well (e.g. avian influenza, Salmonella bacteria). Take care handling live or dead birds, poultry products and droppings. Eggs, meat and blood from all poultry should be well cooked or heated to kill any germs.

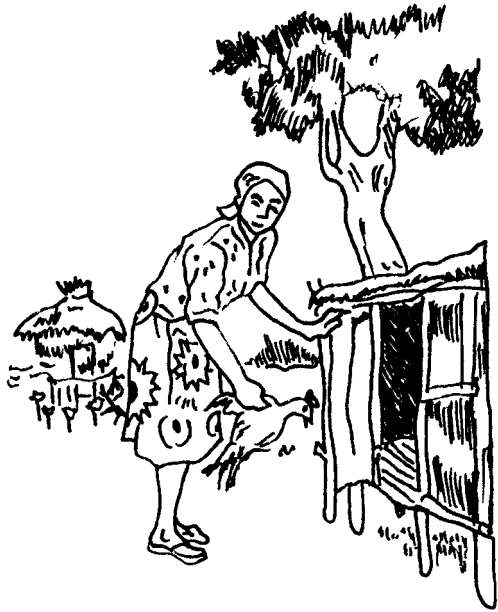

Figure 30: Keep newly acquired animals separated from your flock

Disease prevention

Diseases in chicken can often be prevented by:

- providing clean water, good food, housing and care (See Chapter 5 and 6 on how to avoid nutritional diseases and deficiencies.)
- applying hygiene and biosecurity measures (see below)
- vaccinating against viral diseases present in the area (see below)

Disease treatment

Viral diseases *cannot* be cured with any medicines. For bacterial and parasitic diseases, there are medicines such as antibiotics, coccidiostats, de-worming drugs, herbs etc. Ectoparasites can be treated by applying oil, kerosene or pesticides. The right diagnosis is important, so you can choose the right treatment. When chickens are treated with medicines, residues of the drugs can be present in meat and/or eggs for some time. Do not consume these products.

7.2 Hygiene and biosecurity

What is biosecurity? It is a way to avoid contact between animals, men and microbes. The aim of hygiene and biosecurity is to prevent infectious diseases, and mortality and financial losses caused by them. This is done by:

- reducing the number of microbes in and around chicken houses and runs by cleaning and disinfecting houses and equipment
- taking measures to keep pathogens away from farms and chicken houses and runs.

The more birds you have, the more attention you should pay to hygiene and biosecurity, as losses from infectious diseases can be very high. Note that, although most microbes can be killed with disinfectants like lime wash or *virkon*, these substances are not intended for use on animals, whether externally or internally.

See figure 31: hygiene, observation of animals, staying in touch with a veterinarian and reporting diseases are the main elements of prudent biosecurity on your farm!

How to prevent pathogens from becoming effective?

The following measures can be applied by both commercial and backyard poultry farmers.

When starting a poultry farm, keep a distance from other poultry farms or houses. Note the direction the wind normally comes from. Beware of bird markets, and always keep newly bought birds apart from your poultry flock for 2 weeks, to be sure they do not carry diseases.

Keep scavenging chickens or ducks apart from your commercial poultry flock, as they can introduce new germs. Do not allow any visitors in your chicken houses. Vets are especially dangerous! Make sure that persons entering poultry houses change their footwear.

Humans, wild birds, vermin: they all visit other places as well. Make sure your houses, feed storage and water tanks are bird-proof.

Beware of used egg trays. You may not know where they come from. Sell chickens, eggs, or old litter outside your farm or at the farm-gate.



practice backyard
biosecurity



look for signs



report sick birds

Figure 31: Biosecurity on the farm (APHIS)

Keep different species of birds apart. Keep birds of different ages apart, except for hens and their baby chicks. On a farm with birds of

different ages, always go from the younger and weaker birds to the older ones, and never from old to young.

On larger commercial farms, only keep birds of one age at one time. After each batch, clean and disinfect all the houses. This is the ‘all-in all-out principle’.

Hygiene measures in chicken houses

Keep chicken houses/shelters dry and clean; keep the area around houses clean too, as rubbish attracts rats and wild birds, and the germs they carry.

Clean drinkers and feeders regularly, making sure that drinkers do not overflow. Put overflowing drinkers on slats or bricks. Provide clean drinking water that is not from a pond, to prevent outbreaks of water-borne diseases like fowl cholera.

Do not let birds have contact with their droppings, which can be collected under slats and perches (see Chapter 4). Renew litter regularly, and never store old litter near chicken houses. Bear in mind the wind direction. Keep stocking density down, as infected animals excrete many microbes and disease can spread rapidly.

How to deal with sick and dead birds

Isolate sick birds from the flock, and kill them if they cannot be treated. Slaughter weak birds, as their disease



Figure 32: Burning dead birds (FAO)

resistance is low. Burn or bury all dead birds as soon as possible (figure 32 and figure 33).

7.3 Vaccination

As some viruses can spread by air, hygiene and biosecurity measures will often not be sufficient to prevent infection. Vaccination is therefore very important for preventing infectious diseases, especially viral diseases like Bird Flu and Newcastle Disease. Vaccines consist of weakened or killed pathogens, and should only be given to healthy birds. After vaccination, birds can develop resistance to the disease, and can be protected from it for some time. Live (weakened)



Figure 33: Burying dead birds (FAO)

vaccines can be given in many ways, such as via drinking water, beak dipping, eye drops, spray, etc. See figure 34. Such vaccines provide rapid protection, taking effect within a few days.

A disadvantage of live vaccines is that they are very temperature sensitive, so they should never be kept without refrigeration. Once dissolved, they should be used within a few hours. Live vaccines should never be mixed by poultry farmers themselves. Drinking water vaccination is less reliable than vaccination with eye drops, when all the birds get the vaccine individually.

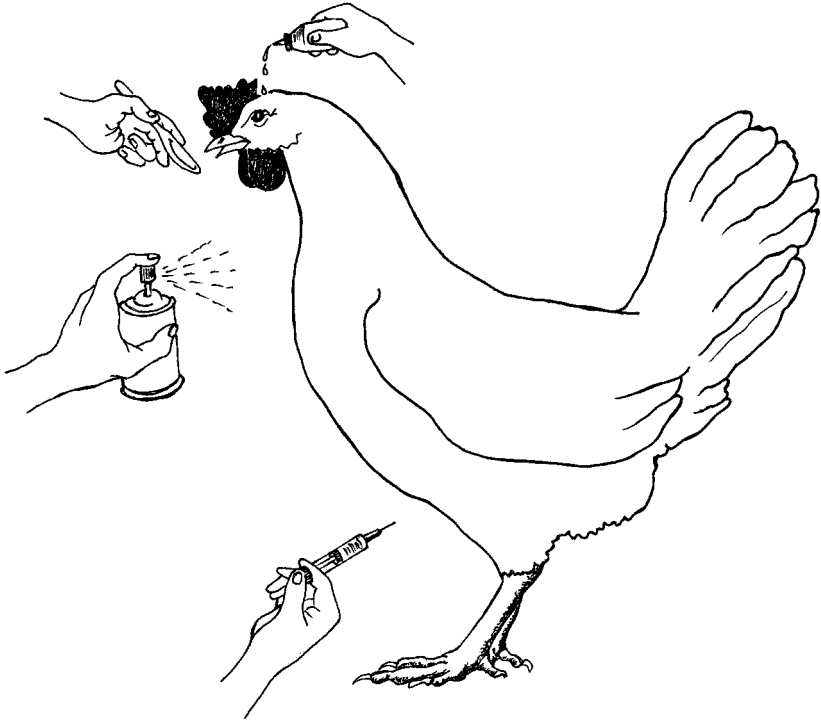

Figure 34: Several vaccine application methods

Killed, or inactivated, vaccines are generally more costly than live vaccines. They can only be given by injection, and they take several weeks to take effect. However, they offer protection for longer than for live vaccines. Killed vaccines are also less temperature sensitive and can be used for several days.

In some developing countries, thermo-stable or temperature-resistant live vaccines are available, which are good for use in rural areas. Vaccines against Newcastle Disease have been developed by ACIAR in Australia. See appendix Internet Addresses.

7.4 Parasites and feather pecking

Worms

Worms (roundworms or tapeworms) are common in family chicken and commercial chicken on litter systems. These parasites can cause poor growth, diarrhoea and low production. All chicken should be treated twice a year. This can be combined with regular Newcastle Disease vaccination.

External parasites

External parasites like fleas, lice, ticks and mites (figure 35) can cause a lot of discomfort to chicken by sucking blood and damaging the skin and feathers. Chicken can be treated with pesticides, and the sand for dust-bathing can be mixed with ashes or sulphur. Tobacco leaves in the nests also act as insect repellents. Scaly legs (crusts on legs caused by mites) can be treated by dipping them in kerosene or rubbing them with fat, oil or shea butter.

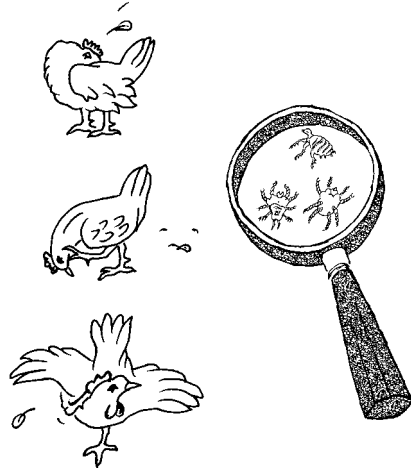

Figure 35: Scratching birds and the causing external parasites (Poultry Network)

Feather pecking and cannibalism

Feather pecking, as shown in figure 36, is abnormal behaviour. It is often seen in commercial chicken that are under stress due to mistakes in rearing, housing or management. Feather pecking is not seen among traditional poultry, whose baby chicks learn from their mothers to peck the soil for food, and not each other. Among confined poultry, however, birds can start pecking from boredom and frustration due to:

- high stocking density
- too little feeding or drinking space
- insufficient laying nests
- lack of litter or scattered grain

- lack of perches to rest on
- lack of sand to take a dust-bath.

Fleas, lice and ticks can also stimulate birds to peck. Too much light, especially in the laying nests, will lead to vent pecking and cannibalism as well. Some birds can be ‘initiators’ of feather pecking in a flock. Remove these birds before others start to imitate them. Teach young chickens to scavenge and peck the soil from the very first week, by scattering some grain on the litter. From 3-4 weeks they should learn to use perches at night and when they want to rest. Chickens resting on perches, as shown in figure 37, do not peck!

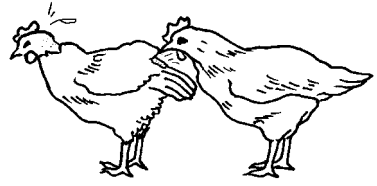

Figure 36: Feather pecking can cause cannibalism (Poultry Network)

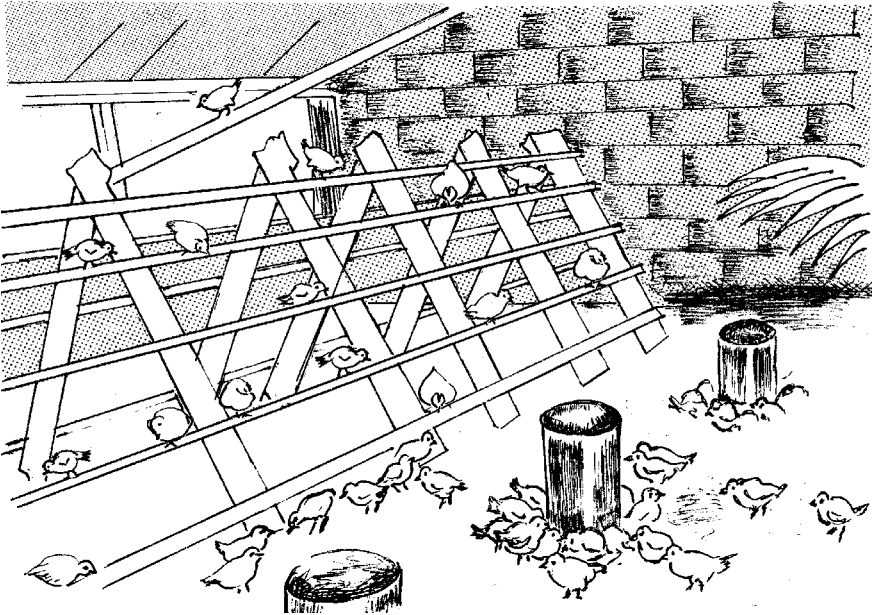

Figure 37: Sitting bars in the chicken house can prevent feather pecking

8 Hatching and raising chicks

On small subsistence farms, eggs will mainly be hatched using brooding hens. On more commercial farms, artificial hatching using a small incubator is also possible. This will depend primarily on how many chicks you wish to hatch at the same time. To make sure that a business with many chicken runs well, it is important that all the chicks hatch at the same time. This is very difficult to ensure using brooding hens because the hens do not all become broody at the same time. Buying a small incubator can then be a good idea. It may be possible to buy it together with a few other chicken breeders.

8.1 Hatching using brooding hens

One brooding hen is capable of hatching 8-10 eggs at the same time. If about 70% of the chicks hatch, this means that each brooding hen gives 6-7 chicks. However, the mortality rate among young chicks can be very high. Your experience and the extent to which you can minimise deaths among young chicks determine, therefore, how many brooding hens you will need.

Use the following criteria to choose which eggs to hatch:

- The eggs selected must, of course, be fertilised. This is rarely a problem if there is a cock present. On average, one cock is needed for every 10 hens. If a cock is not normally kept with the hens, he must be put in with the hens two weeks before the hatching period.
- Use undamaged and clean eggs which are neither too small nor too large. The best results can be expected if you choose medium sized eggs from hens which lay well.
- Collect the eggs regularly, e.g. three times a day. Let the eggs cool down as quickly as possible.
- If necessary, keep the eggs for a few days, but preferably not for more than a week. If the eggs have to be kept for a week, they must be stored at a temperature of between 14 and 16 °C. Storing hatching eggs at temperatures below 12 – 14 °C is not advisable. If the

temperature cannot be kept at the recommended level, a shorter storage period is necessary. Eggs can be kept for only three days at 20°C. Write the date of collection on the egg in pencil, to help you remember how long the egg can be stored.

If a hen shows broody behaviour for two days, she can be used for brooding. Brooding hens must be healthy and not too small. A broody hen can be recognised by:

- a characteristic broody sound
- a wrinkled comb
- an unwillingness to leave her nest
- the collecting of as many eggs as possible in her nest.

Before allowing a hen to brood, it is best to treat her with an insecticide against flies and lice. If flies and lice are a problem, the treatment should be repeated after 10 days. In the beginning, the hen will brood irregularly until she can sit on 6 to 12 eggs. It is best not to let the hen sit on selected eggs during this period. Only when she broods regularly can the eggs be replaced with specially selected eggs. Large hens can brood on 14 eggs, but a smaller, local hen brood should be given no more than 8 eggs to brood on.

Use a clean and parasite-free brooding coop. The coop should be about 35 x 35 cm, and 40 cm high. The nest consists of straw, hay or dry leaves, and is about 25 cm wide. To stimulate the brooding process, you can place the coop in a cool, dark place, or partially cover it. The brooding place must be free from other chickens and protected against dogs, rats, snakes etc. It is a good idea to add a run onto the brooding coop. Place good feed and clean, fresh water near the brooding hen.

8.2 Artificial hatching

It is possible to buy small incubators which hatch out a larger number of eggs at the same time. You can, however, also build such a device yourself using relatively simple materials. To find out how to make

such a device, please see Agrodok 34: *Hatching eggs by hens or in an incubator*. This booklet describes how to construct an incubator capable of hatching 50 eggs at the same time.

The most important requirements for artificial hatching are:

- You must be able to regulate the temperature you need. This must be about 38°C (100 F). Only a simple heat source is needed. The temperature must be kept as constant as possible.
- The relative humidity of the air must be quite high, at about 55-60%. It must be increased to about 75% after the 18th day, by placing bowls of water in the incubator. Of course you must keep the bowls filled.
- Fresh air must be circulated through the incubator regularly.
- The eggs must be turned regularly (preferably 2 or 3 times a day). To turn an egg, you must rotate it 180° about its longest axis.

With the proper care and effort you can achieve almost the same results with artificial hatching as with brooding hens. Still, it is usually better to count on a slightly lower success rate, e.g. 65-70% instead of 75-80%. The brooding period should be timed so that the chicks hatch in the dry season.

8.3 Raising the chicks

The chicks hatch after 21 days of brooding. If the eggs have been hatched by a hen, she will immediately take care of the chicks. It is a good idea to keep the hen with her chicks in a separate coop during the first few weeks. The very first thing the chicks need is fresh water, so make sure this is always available. They only start needing food after one day. If you are not able to use bought feed, you can try to make as good a feed as possible by mixing the following ingredients: broken maize or millet (with a source of protein like boiled eggs for the first few days), kitchen and slaughter wastes, and greens such as leaves, grass, etc. The greens will provide the chicks with most of the vitamins they need.

If the chicks have been hatched artificially, you must take care of them yourself from the very beginning. Place the chicks in a thoroughly cleaned space and make sure that the temperature is correct for the first few weeks. After four weeks, it is not usually necessary to give extra heating, except perhaps at night. The temperatures needed for the first weeks are given in table 9.

Table 9: Heating guidelines

Age (weeks)	Required ambient temperature (°C)
0 – 1	35 - 32
1 – 2	32 - 29
... after two weeks chicks are allowed to go outside ...	
2 – 3	29 - 26
3 – 4	26 - 23
4 – 5	23 - 20

An oil or petroleum lamp or a light bulb can be used to heat an area in a several different ways. The chicks are placed in a separate coop. A petroleum lamp is put in the coop, and is fenced off with some wire gauze to protect the chicks against too much heat. The top of the coop is also wired off to protect them against rats, dogs and cats. The best way to see if the temperature in the coop is just right for the chicks is by observing their behaviour. If it is too cold, the chicks huddle together; if it is too hot, they stay as far away from the heat source as possible. If the temperature is just right, they will use all of the available space.

Coops for chick-raising can have a floor made of chicken-wire. For the first week, the wire should be covered with newspaper or something else, which should be renewed every day. When the chicks are capable of walking on the wire, this cover is no longer necessary. In this way, the chances of parasite infection are minimised, since the chicks do not step in their own faeces.

Make sure that the chicks receive plenty of light during their first few days, so that they can find their water and food. After that, the light intensity is less important. In fact, too much light can be harmful as it can stimulate the chicks to start pecking each other.

At about four to five months, depending on their genetic potential and the environment, the first hens start to lay eggs. Modern hybrids are reaching laying maturity at a younger and younger age: 20 weeks or even earlier. As was mentioned in chapter 4, hens can be stimulated to reach laying maturity earlier by artificially lengthening the days during their growing period. However, it is not a good idea to stimulate the hens to start laying too early, so you should avoid extra lighting in this period. If you still wish to make the chickens eat more, give extra lighting in such a way that as the chickens get older the daylight period remains the same. If you have no artificial lighting, it is best to raise the chicks during the season with the shortest day. Then the hens start laying as the days get longer, which stimulates egg production.

9 Improving local chickens

Local chickens are not usually pure-bred animals, but the product of years of crossbreeding. Due to a long adaptation process, they are more resistant to high temperatures and probably also better adapted to more difficult circumstances. However, chickens in the tropics have a low body weight, which is why they lay small eggs. And their production is low: about 50 eggs per year. Many small farms must, therefore, use most of the eggs laid to maintain the chicken population.

The production of local chickens can be improved in two ways:

- replacing local cocks with cocks of more productive breeds
- culling unproductive animals.

Such measures must always be taken together with measures for improving the conditions of the poultry farm.

9.1 Cock exchange programmes

In various countries, cock exchange programmes have been successfully carried out. In such programmes, all the existing local cocks are replaced with new ones. The replacements may be cocks of an outside breed, such as the Rhode Island Red, or hybrid cocks. Pure-bred cocks can be found in some places where a cross-breeding programme is under way. Such a programme usually tries to spread the cross-bred offspring to small chicken farms. Depending on the management of the farm, the first generation of chickens after the cocks are replaced will produce more. A cock exchange programme should be repeated from time to time, e.g. every five years. During this period it is also advisable to regularly replace your cocks with those of a neighbour or someone else, in order to avoid in-breeding.

9.2 Culling

Culling is used to immediately remove unproductive hens and sick chickens from the population during the production period. This in-

creases the production efficiency because you do not waste feed on unhealthy or unproductive chickens. You can already start culling during the growing period. Several weeks before the hens start laying you can make a rough selection, removing those chickens which are too light, pale, or underdeveloped. You can get rid of them immediately, but sometimes it is worth keeping these slow developers in a separate space, to give them a chance to catch up. You can then regularly cull during the production period. The difference between good and poor layers can be seen with the help of the traits mentioned in table 10.

Table 10: Difference between good and poor chickens

Trait	Productive chicken	Unproductive chicken
General condition	lively	dull
Weight	good	usually fairly light
Wattle and comb	soft; bright red	pale and rough
Eyes	lively	dull; yellow rims
Pigment (yellow breeds)	disappears	stays longer
Cloaca	large, soft, moist	shrivelled, dry
Distance between lay bones	large (± 5 cm)	small (± 2 cm)
Distance between breast-bone and lay bones	large (± 8 cm)	small (± 4 cm)
Skin	soft, loose	thick, fat under the skin

A dull hen with a pale, rough wattle and comb can be picked out easily and examined further. Very fat, healthy-looking chickens can be selected to check the distance between their lay bones. If it is less than 2-3 cm, they will not lay eggs. Should a hen become broody when you do not want her to, this can be stopped. Place the hen in a separate coop with a floor of chicken-wire and feed her well. After a few days she will start laying again.

10 Products and by-products

Eggs

Eggs have a high nutritional value. Both the egg-white and yolk contain high quality protein (for both, this is at least 10% of their own weight). The egg-yolk has about 33% fat. Eggs also have a lot of vitamin A and D, and some vitamin B.

If you wish to sell eggs, you need a good storage place for them. Only store fresh, clean eggs with undamaged shells. The storage place for the eggs must be clean and as cool as possible, especially if the eggs must be kept for more than a week. A dark space is the most suitable for this. If the eggs have been fertilised, it is even more important to have a cool storage place. At high temperatures (e.g. above 25°C), embryo development starts to take place.

Chicken meat

Hens which have stopped laying will usually be used for feeding your family. If you want to sell the meat, it is often better to sell live chickens. There is a good market for the meat of local chicken breeds. Chicken meat is a high quality and healthy food with an average protein content of about 20% and relatively little fat (about 7%), especially under the skin.

Chicken manure

Chicken manure is very rich in nitrogen and other minerals, especially phosphorus, calcium and potassium. This is shown in table 11. It is therefore a very good fertiliser. Manure which is stored for a long time will lose part of its value as fertiliser. Keep the manure as dry as possible. This minimises the loss of minerals and problems with flies. Regularly removing the manure under a chicken house will also reduce the loss of minerals.

There are several other uses for chicken manure. It can be put into fish ponds, where some of it is eaten by the fish, although most of it is

used by the plants, which are then eaten by the fish. In many countries, dried chicken manure is fed to cattle or goats, e.g. in combination with grains and molasses. For this, the manure must not be too old, and must be dried quickly so that it keeps as many of its nutrients as possible. And gas can be made from the manure, using a biogas digester. The slurry which is then left over is still a very good fertiliser for use on the land and in fish ponds.

Table 11: The average composition of chicken manure

	Fresh manure (%)	Litter manure (%)
Dry matter	20 - 22	50
Nitrogen	1 - 1.5	1 - 2
Phosphorus (P ₂ O ₅)	1 - 2	2
Potassium (K ₂ O)	0.7	1
Calcium (CaO)	2.2	3

Slaughter waste

Slaughter waste produced on your farm is a very good feed supplement if it is ground up and dried well. The waste must be sterilised, or else there is a large chance of transmitting diseases. It is also very important that carcasses of birds which die during the production period are removed as quickly as possible. This should be done by burying or burning them as shown in figure 32 and figure 33.

11 Farm records

As your business grows larger, you are strongly advised to improve your business administration so that you record the most important production figures. You can use these data to identify the weakest points in your business, so that you can tackle those problems better. To be able to do this well, you need to have some idea of the most important data of an egg-laying business.

A reliable administration must be kept up to date daily. This takes time and money, but it is the only way to make your business run efficiently.

11.1 Important data

The most important data are:

- laying percentage and length of laying period
- egg weight
- feed consumption
- chicken losses.

Laying percentage and length of laying period

In countries where the poultry industry is well-developed, the hens start laying when they are about 20 weeks. The production of the whole chicken stock then rises quickly to a peak after another eight weeks. At that point, most of the chickens lay an egg almost every day. There are almost as many eggs to be gathered every day as there are chickens. This ratio of the number of chickens to the number of eggs gathered on one day is called the 'laying percentage'. When the peak in production is reached, e.g. when the chickens are 28 weeks, the laying percentage can be as high as 90%.

Productive poultry stock is characterised by a quick rise of production to a peak. The peak production is high and maintained for some time. It then only slowly decreases. This results in a high average laying percentage over the whole laying period.

Depending on the production level, the price of eggs and of non-productive chickens at the end of the laying period, the laying period for a well-run poultry business lasts 12-14 months. After this the chickens are sold or slaughtered. This can be shown on what is known as a production curve.

Instead of getting rid of the chickens at the end of the laying period, they can be given a rest period, when they are allowed to moult. They can then go through a second laying period, and perhaps even a third. Chickens in the tropics are said to naturally start moulting after laying for a year. This tends to happen in the season with shorter days. The moult can be stimulated by using extra artificial lighting. It is also possible to trick the chickens into moulting. Limit the first production period of the chickens to only 8-10 months. Then force them to moult by giving them less and poorer quality feed. After the moult, the production increases again and the quality of the eggshells improves too. Making use of a moult can be worthwhile if:

- the purchase price of chickens is high
- the egg price is low at the time
- the price received for old chickens is also low
- better eggshells raise the price received for eggs.

The price received for old hens which have stopped laying is usually high in the tropics. Since it is difficult and risky to get all the chickens to moult at the same time, it is probably preferable to keep layers for only one laying period.

Egg weight

In many countries eggs are sold by weight, so the weight of eggs is also of importance. The first eggs at the start of the laying period are small. The weight of the eggs increases until the end of the laying period. The egg weight partly depends on the chicken breed. It can also be influenced by the feed given and the environment, in particular the temperature. The egg weight is measured by weighing a number of eggs from time to time.

Feed consumption

Feed costs are, as a rule, the greatest expenditure of a poultry farm. It is therefore important to have a good idea of how much feed is eaten, and in particular the amount of feed needed per egg or per kg of eggs or meat. This is called the feed conversion.

On a commercial poultry farm using bought compound chicken-feed, the feed consumption per chicken per day is 100 to 120 g. This depends on the kind of chicken (light or medium weight), the feed quality and the air temperature. If you give the chickens home-made feed, consumption may be higher, especially if the feed contains a lot of crude fibre such as bran.

Chicken losses

During the laying period, chickens will regularly die. In general, a reasonably well-run poultry farm loses a total of about 6-8% of its chickens each year, or just over 0.5% per month. If you lose more than this, it is important to find out why.

11.2 Cost pricing

There are many ways of organising your administration. It is important to calculate the cost price of the eggs produced in order to avoid selling the eggs for less than it costs to produce them. Make a distinction between costs which keep coming back, and one-off costs. One example of how to organise your administration is given below.

It is also possible to exclude the labour costs. If you then subtract the total net costs (excluding labour costs) from the income provided by the eggs, you will have calculated the sum you have earned with your labour (the labour income).

See next page.

Calculation of cost price of eggs

Basic data to be specified:

1 Investment costs of buildings and equipment:

Depreciation of buildings : 5 %

Depreciation of equipment : 10 %

Maintenance of buildings : 2 %

Maintenance of equipment : 3 %

Interest: going rate divided by 2 (depreciation from 100% to 0% !)

2 Purchase costs of chicks or pullets

3 Feed consumption and feed price

4 Production

A. Direct costs

- Cost of pullets	----
- Feed costs	----
- Oil or petroleum lamp or electricity	----
- Water	----
- Health care costs (medicine, disinfection, vaccinations)	----
- Litter	----
- Interest over stock [interest % * 1/2 (pullet+feed costs)]	----
- Miscellaneous	---- +
Subtotal	-----

B. Calculated (fixed) costs

- Housing	----
- Labour	---- +
Total gross costs	-----

... subtract ... :

C. Secondary products

- Manure sold	----
- Hens sold	---- -
Total net costs	=====

Cost price calculation: Total net costs = (A + B) – C

Appendix 1: Diseases and parasites

Table 12: Infectious poultry diseases caused by viruses

Important: chickens diseased by these viruses cannot be cured! No treatment exists and therefore prevention and biosecurity are essential.

Disease name	Transmission	Symptoms	Prevention
Newcastle Disease	Bird to bird and spread by air	Respiratory problems, diarrhoea, drop in egg production, twisted necks. High mortality: 50-100%	Vaccination (minimal twice a year). Check local vaccine availability
Avian influenza (= bird flu)	Bird to bird; migratory birds; very rapid spread; some virus types can affect humans	Dull birds, respiratory problems, swollen heads. Very high mortality, up to 100%. Death without symptoms may occur.	Vaccination (if available) Culling of infected birds. Burn or bury dead birds. Do not eat sick birds! Biosecurity important. Avoid contact with wild birds
Infectious bronchitis	Bird to bird and by air	Respiratory troubles, drop in egg production, eggs with abnormal shape and shells.	Vaccination (repeated)
Fowl pox (= avian pox)	By flies and mosquito's	Scabs on comb, wattles eyes; cheesy pox in mouth	Vaccination
*) Gumboro disease (= infectious bursal disease)	Bird to bird; contaminated litter/equipment; mainly in commercial birds up to age of 8 weeks	Diarrhoea, listless chickens; high mortality	Vaccination (1 or 2 times; in first weeks)
***) Marek's disease	Mainly by air; Virus in commercial birds; infection in first days of life	Paralysis, tumours, wasting from age of 14 weeks	Vaccination on first day of life in hatchery; culling affected birds
*) Gumboro disease: the virus affects mainly commercial birds up to an age of 8 weeks			
***) Marek's disease: the virus is found in commercial birds which are infected in the first days of their life			

Table 13: Infectious poultry diseases caused by bacteria

Important: chickens infected with these bacteria can be treated with antibiotics, but they will not always be cured!

Prevention and biosecurity are therefore essential.

Disease Name	Microbial cause	Transmission	Symptoms	Prevention
Chronic respiratory disease	Mycoplasma	Bird to bird and via eggs from parent to chick	Respiratory signs, drop in egg production.	Use of Mg-free flocks. Vaccination for layers and breeders
Infectious coryza	Haemophilus	Bird to bird, dust, drinking water	Nasal discharge, swollen face and wattles,	Vaccination
Pullorum disease *)	Salmonella pullorum	Via eggs from infected breeder hens; mainly in young chicks	White diarrhoea, dull chicks just after hatching. High mortality.	Testing and culling of carrier breeder hens
Fowl typhoid **)	Salmonella gallinarum	Via droppings and equipment; mainly in adult birds	Dull chickens; diarrhoea, high mortality (60 %).	Vaccination, hygiene
Fowl cholera (Pasteurellosis)	Pasteurella	Bird to bird, contaminated water and feed	Dull birds in acute cases, blue combs and high mortality, in chronic cases swollen wattles.	Vaccination, hygiene
*) against Pullorum disease, antibiotics are rarely effective				
**) effect of antibiotics against Fowl typhoid is uncertain				

Table 14: Poultry diseases caused by parasites

Parasite name	Parasitic cause	Transmission	Symptoms	Prevention	Treatment
Coccidiosis	Eimeria parasites in digestive tract	Infected droppings and litter; via older to young birds;	Listless birds; diarrhoea can be bloody; mortality,	Clean houses and feeders dry litter low animal density	Sulfa or other anti-coccidial medicines in drinking water
Worm infections	Round worms and tapeworms	Via infected droppings	poor growth, low production	Clean house, change litter, avoid overcrowding	Anti-worm medicine twice a year.

Appendix 2: Nutrition tables

Values obtained by chemical analysis should take precedence over the average figures given in table 14 and table 15. These nutrition tables have been provided by PTC⁺ and refer to a variety of sources.

The diets are based on different ingredients. For instance, if mainly ground maize is available, diet 2 or 3 can be chosen. In diet 4, green fodder (*Barseem trif. Alexandrium*) is offered in between meals.

Table 15: Some examples of formulated rations for layers

Layers diet number	Diet 1 (%)	Diet 2 (%)	Diet 3 (%)	Diet 4 (%)
Rice bran	<u>57</u> *)	15	<u>20.5</u>	10
Broken rice	8	<u>20</u>	<u>19</u>	-
Ground yellow maize	7	<u>29.5</u>	<u>20</u>	<u>25</u>
Wheat bran	-	-	-	<u>15</u>
Ground wheat	-	-	-	<u>15</u>
Wheat	-	-	-	<u>15</u>
Ground barley	-	-	-	-
Barley	-	-	-	10
Millet	-	-	-	-
Ground soy bean cake	4	5	-	-
Ground groundnut cake	5	5	-	-
Bean	-	-	-	5
Ground sesame oil cake	-	-	<u>22</u>	5
Decorticated cotton seed meal	-	-	-	10
Coconut or copra meal	5	5	-	-
Ground dried legume leaf	3	3.5	-	-
Fish meal	7	15	-	2
Blood meal	-	-	12.5	-
Meat scraps	-	-	-	3
Shark or cod liver oil or vitamin A + D3	1	-	0.5	0.5
Dried skim milk	-	-	-	-
Bone meal	-	-	1.5	2
Ground limestone	-	2	-	0.5
Ground shells	2	-	1.5	-
Common salt	1	-	0.5	0.5
Mineral mix	-	-	2	-

*) The bulkiest ingredients in the diet are underlined

Table 16: Some examples of formulated rations for chicks

Chicks diet number	Diet 1	Diet 2 (0 – 8 weeks)	Diet 3 (8 - 12 weeks)
Rice bran	26	10	10
Broken rice	16	-	-
Yellow maize	16	20	20
Ground wheat	-	20	15
Wheat	-	10	10
Barley	-	10	20
Groundnut cake	5.4	-	-
Sesame oil cake	10.5	10	5
Decorticated cotton seed meal	-	5	10
Beans	-	10	5
Fish meal	10.5	2	2
Blood meal	2	-	-
Meat scraps	-	3	3
Milk	5.5	-	-
Gram or chickpeas	5.5	-	-
Cod liver oil	0.5	1	1
Bone meal	-	1	1
Salt	-	0.5	0.5
Limestone	-	0.5	0.5
Mineral mixture	2	-	-

Table 17: Vitamins, their functions and sources

Vitamin	Function	Source
A	appetite, digestion, prevention of <i>Xerophthalmia</i> , maintenance of mucus membranes	green grass, lucerne meal, fish meal, corn gluten, yellow corn
B1 thiamine	appetite, digestion, health of nerves, prevention of polyneuritis	green grass, lucerne meal, wheat by-products, milk by-products
B2 riboflavin	growth, hatchability, prevention of curled toe paralysis	green feeds, milk by-products, distiller's, solubles
B12 cyanocobalamin	growth, hatchability	fish meal, meat scraps, deep litter, fermentation products
Biotin	prevention of fatty liver kidney syndrome	soy bean meal, cottonseed meal
Niacin nicotinamide	growth, feathering	liver, yeast, milk
Pantothenic acid	growth, hatchability, prevention of dermatitis	green feeds, milk by-products, meat scraps
Choline	growth and bone development, egg production, perosis prevention, prevents fatty degeneration of liver	green feeds, whole grains
D3	mineral assimilation, egg production, hatchability, rickets prevention, egg shell thickness	fish oils, animal fat, yeast
K	blood clotting, anti-haemorrhagic	green feeds
E	health of reproduction organs	green feeds, whole grains

Table 18: Essential minerals, their functions and sources

Mineral	Function	Source
Salt (sodium chloride)	utilisation of protein, prevention of hypertension, egg production	common salt (0.3 - 0.5% in diet)
Manganese	bone formation, shell strength, fertility of eggs	limestone flour, manganese sulphate, manganese oxide
Iron, copper, cobalt	formation of haemoglobin	supplement, animal products
Iodine	prevention of lethargy	iodised salt
Zinc	growth, feather development, skin health	zinc carbonate, galvanised feeding containers

Table 19: Nutrient requirements of chickens of several age groups and categories

Nutrient requirements expressed as dietary concentrations in air-dry material.

Nutrient in feed	Chicks (0-8 wks)	Growers (pullets) (6-20 wks)	Layers (adult birds)	Broilers (0-6 wks)
Metabolisable energy (kcal/kg)	2800	2750	2750	3000
Crude protein %	20	16	17	21
Crude fibre %	3 - 4	3 - 7	3 - 8	2.5 - 4
Crude fat %	3 - 5	2.5 - 4	3 - 8	4 - 8
Most important amino acids:				
Lysine %	1.0	0.8	0.7	1.2
Methionine %	0.4	0.35	0.35	0.45
Minerals:				
Calcium (Ca) %	1.0	0.8	3-3.5	1.0
Phosphorous (P) %	0.9	0.7	0.9	0.9
Sodium chloride (NaCl) %	0.4	0.3	0.3	0.4
Manganese (Mn) (mg/kg)	50	50	50	60
Zinc (Zn) (mg/kg)	40	40	40	50
Vitamins:				
Choline (mg/kg)	1300	1000	1000	1500
Niacin (mg/kg)	28	25	25	30
Pantothenic acid (mg/kg)	10	10	10	12
Riboflavin (mg/kg)	4	4	4	5
Vitamin A (IU*/kg)	1320	1250	1250	1500
Vitamin D ₃ (IU*/kg)	400	250	350	400
* International units per kg feed				

Table 20: Nutrient content of cereals and grain by-products

Nutrient content	Corn and cob	Maize (white)	Maize (yellow)	Munga	Sorghum	Cane molasses
Metabol. energy (kcal/kg)	2000	3370	3340	3250	3280	1900
Crude protein (N x 6.25) %	7.6	8	9	10.5	10	3
Crude fibre %	6	2	2	2.5	2.1	1
Crude fat %	2	3.6	3.6	1.5	3.1	-
Lysine %	0.2	0.24	0.27	0.20	0.22	0.02
Methionine %	0.12	0.14	0.16	0.27	0.18	0.02
Calcium (Ca) %	0.12	0.04	0.04	0.05	0.05	0.7
Total phosphorus (P) %	0.35	0.4	0.4	0.4	0.3	0.1
Zinc (Zn) (mg/kg)	20	23	23	20	15	10
Manganese (Mn) (mg/kg)	13	5	5	5	13	42
Sodium chloride (NaCl) %	0.07	0.08	0.08	0.05	0.13	-
Choline (mg/kg)	360	440	440	440	700	850
Niacin (mg/kg)	4	16	16	16	32	33
Pantothenic acid (mg/kg)	3	3.3	3.3	3.3	9	38
Riboflavin (mg/kg)	0.6	0.7	0.7	0.5	1	3
Vitamin A (IU*/kg)	-	-	4400	-	-	-
Vitamin D ₃ (IU/kg)	-	-	-	-	-	-
* International units per kg feed						

(Table 20: continued)

Nutrient content	Hominy chop	Maize bran	Maize Germ	Wheat bran	Wheat pollard
Metabol. energy (kcal/kg)	2700	2300	3000	1710	2500
Crude protein (N x 6.25) %	9	7	13	14	16
Crude fibre %	6	13	5	12	10
Crude fat %	6.3	5.8	3	3.5	3.6
Lysine %	0.3	0.3	0.35	0.6	0.75
Methionine %	0.08	0.08	0.14	0.3	0.2
Calcium (Ca) %	0.05	0.03	0.04	0.15	0.1
Total phosphorus (P) %	0.5	0.5	0.5	1.1	1.1
Zinc (Zn) (mg/kg)	23	23	20	130	130
Manganese (Mn) (mg/kg)	7	7	13	120	110
Sodium chloride (NaCl) %	-	-	0.25	0.12	0.05
Choline (mg/kg)	440	440	1500	1000	1000
Niacin (mg/kg)	50	40	40	200	90
Pantothenic acid (mg/kg)	7	5	4	29	16
Riboflavin (mg/kg)	2	1.5	3	3	1.6
Vitamin A (IU*/kg)	5000	4500	4000	1000	1000
Vitamin D ₃ (IU/kg)	-	-	-	-	-
* International units per kg feed					

Table 21: Nutrient content of protein sources from plant and animal products

Nutrient content	Soy-beans full fat	Soy-bean oil meal	Sun-flower cake	Ground nutcake dehulled	Cotton seed cake	Cotton seed c. dehulled
Metabol. energy (kcal/kg)	3250	2500	2100	3150	1900	2100
Crude protein (N x 6.25) %	37	44	29	49.5	36	40
Crude fibre %	4	6	20	12	18	12
Crude fat %	15	2	3.4	5.6	3	5
Lysine %	2.4	2.9	1.5	2.20	1.4	1.6
Methionine %	0.51	0.6	0.8	0.43	0.43	0.52
Calcium (Ca) %	0.22	0.25	0.41	0.16	0.2	0.2
Total phosphorus (P) %	0.52	0.6	0.95	0.8	1.2	1.2
Zinc (Zn) (mg/kg)	24	28	20	35	40	40
Manganese (Mn) (mg/kg)	26	30	23	18	20	20
Sodium chloride (NaCl) %	0.29	0.34	-	0.12	0.5	0.5
Choline (mg/kg)	1730	2000	280	2000	2000	2100
Niacin (mg/kg)	17	20	250	200	40	40
Pantothenic acid (mg/kg)	23	12	38	30	10	10
Riboflavin (mg/kg)	22	26	3	5	5	5
Vitamin A (IU*/kg)	290	340	300	330	300	300
Vitamin D ₃ (IU/kg)	-	-	-	-	-	-

* International units per kg feed

(Table 21: continued)

Nutrient content	Alfalfa meal	Fish meal	Meat + Bone meal	Blood meal	Skim milk (dried)
Metabol. energy (kcal/kg)	700	3300	2900	3020	2690
Crude protein (N x 6.25) %	16	65	48	80	33
Crude fibre %	25	1	1	-	-
Crude fat %	3.8	8.5	13	0.6	1
Lysine %	1	5	3	7	2.5
Methionine %	0.15	1.8	0.5	0.9	0.8
Calcium (Ca) %	1.40	5.	12.5	0.28	1.3
Total phosphorus (P) %	0.3	2.7	5.5	0.22	1.
Zinc (Zn) (mg/kg)	35	68	100	80	25
Manganese (Mn) (mg/kg)	50	40	12	5	2
Sodium chloride (NaCl) %	0.50	2.5	1.75	1.5	1.65
Choline (mg/kg)	800	3000	1500	750	1100
Niacin (mg/kg)	25	60	40	30	11
Pantothenic acid (mg/kg)	14	8	3	1.1	3
Riboflavin (mg/kg)	13	6	305	1.5	20
Vitamin A (IU*/kg)	2000	500	200	100	260
Vitamin D ₃ (IU/kg)	-	300	60	50	60

* International units per kg feed

Table 22: Nutrient content of natural mineral supplements

Nutrient content	Bone-meal	Mono-calcium phosphate	Di-calcium phosphate	Limestone flour	Shells
Metabolisable energy (kcal/g)	1500	-	-	-	-
Crude protein % (N x 6.25)	25	-	-	-	-
Crude fibre %	-	-	-	-	-
Crude fat %	-	-	-	-	-
Calcium (Ca) %	22	16	22	37	38
Total phosphorus (P) %	9	20	18	0.04	-
Zinc (Zn) (mg/kg)	425	-	-	-	10
Manganese (Mn) (mg/kg)	30	-	700	1000	5
Salt (NaCl) %	0.8	-	-	0.1	0.2
Niacin (mg/kg)	4	-	-	-	-
Pantothenic acid (mg/kg)	2	-	-	-	-
Riboflavin (mg/kg)	0.9	-	-	-	-

Appendix 3: Common feedstuffs

Cereals

Bulrush millet (Pennisetum typhoides)

This millet has very small grains and resembles maize in composition and feeding value, but is considerably higher in protein value. It has a similar feeding value to barley and, like barley, it promotes the production of white fat, because of its low pigment content. This cereal is very prone to infection by the fungus *Claviceps purpurea* in the dry season, which can produce toxins that are dangerous to both humans and poultry.

Finger millet (Eleusine coracana)

This grain has the advantage that it will not shatter if the crop is left unharvested after the rains. It has a lower protein but slightly higher fibre content than bulrush millet. It can be used in diets for both growing and laying poultry.

Wheat (Triticum aestivum)

Wheat is mainly used for human consumption, particularly for bread making. It has a slightly lower energy content than maize. Hard wheat has an average protein content of 13-15% whereas soft wheat has a much lower average content of about 10%.

Barley (Hordeum vulgare)

Barley's protein level is 10% and its fibre content is 5%, which makes it less suitable for inclusion in diets for highly productive laying birds and broilers, especially in hot climates. It could be a useful ingredient in the diet of broiler breeders if you want to reduce food intake.

Rice (Oryza sativa)

Threshed rice has a thick fibrous husk which contains up to 20% silica, and in this form it is unpalatable to poultry. The outer casing is easily removed to produce a much more palatable product, brown rice.

This food is high in starch and low in oil and is a valuable poultry food. The rice husks are often used for litter in poultry houses.

Cereal by-products

Rice-bran

This is a by-product of milling rice. It is high in fibre and oil. The oil may cause problems of rancidity in feed during storage. It probably should not be added to poultry diets at levels above 20% of the total ration.

Maize bran

This consists of the outer coating of the maize kernel. It contains 15% fibre and is low in metabolisable energy. It is not a suitable ingredient for inclusion in the diet of high producing broilers or laying hens.

Brewer's dried grains

These are normally a by-product of barley, but those obtained from sorghum have a very similar composition. The protein content is in the region of 20% and fibre content 14%. This high fibre content means that they are of limited value for poultry.

Dried brewer's yeast

This is produced by drying waste yeast from breweries. It contains practically no fibre or oil and is a good source of phosphorous. It also contains 40-45% protein of a very high biological value. It is very rich in B vitamins.

Other energy foods

Cassava, tapioca, yucca

It is not recommended that fresh cassava be fed to poultry because of its low dry matter content and the presence of cyanogenetic glucosides. The intact tubers of cassava contain little free cyanide but any cutting or bruising releases free cyanide. If the tubers are chopped into thin slices and left in the sun to dry to a moisture content below 14%

the cyanide content is reduced (from 65%) to an acceptable level. This dried cassava can then be milled and fed to poultry. The major problem is that it has a low protein content and the wrong balance of amino acids for poultry. In West Africa certain types of cassava contain virtually no protein. This lack of protein can cause serious nutritional problems in poultry if sufficient high protein foods are not added to the diet.

Final molasses

This is the residue left once raw sugar has been extracted from clarified sugar cane juice. It contains sugars and 10-12% soluble mineral matter. It is not very suitable for feeding to poultry because it leads to diarrhoea and wet droppings, and also sticks to the feathers of poultry. However, a small amount (2-5%) mixed into a ration makes it taste better and reduces dust.

Oil seeds and by-products

Sunflower seed

The seed contains about 25% oil and so its use as a poultry food is limited. The oil content accounts for its exceptionally high metabolisable energy value.

Sunflower oil meal

After obtaining the oil from the seeds (by pressure or by extraction, which will result in oil cake or oil meal respectively), a high protein feed remains. The amount of crude fibre depends on whether the sunflower seeds are de-hulled. If they are not de-hulled, the fibre content limits its use for chickens to about 10% maximum.

Cotton seed cake

Other oil seeds, like cotton seed, can be used as good protein sources for poultry, but cotton seeds contain a chemical called 'gossypol' which will give a bluish colouring to the egg yolk. Therefore, not more than 5% of this should be included in the feed.

Linseed meal from flax

The protein in linseed meal does not effectively supplement the protein in maize or other grains, so it is not suitable as a main component of poultry rations. Linseed meal does have a fair calcium content, averaging 0.37% and is rich in phosphorous, with an average of 0.86%.

Animal protein foods

Generally, animal proteins are more digestible and have a better composition of amino acids than plant protein; with the exception of feather meal.

Feather meal

Producers of large numbers of broilers can make use of the feathers produced by preparing feather meal. This can be done by steaming the feathers and grinding the product. Feather meal is a rich source of protein, high in leucine and cysteine but deficient in lysine, tryptophan and methionine. But if it is not properly processed, feather meal could be a carrier of *Salmonella* bacteria.

Other animal proteins

Another animal protein that could be fed to poultry is blood-meal. This and all other animal protein products must be thoroughly sterilised (cooked) before being mixed into feed, to avoid spreading diseases.

Further reading

Alders, R. (2001). **Controlling Newcastle Disease in Village Chickens**. A Field Manual. ACIAR Monograph No. 82. 112 pp. ISBN 1 86320 307 9.

Alders, R. (2004). **Poultry for profit and pleasure**. Diversification booklet 3. FAO Rome ISBN 92 5 105075 9, 40 pp.

Agromisa (2003). **Chicken farming in the tropics 1: basics**. Educational material no. 32. ISBN 90-5285-006-2, 180 pp.

Agromisa (2003). **Chicken farming in the tropics 2: lecture notes**. (ed. E.H. Ketelaars) Educational material no. 33. ISBN 90-5285-060-7, 144 pp.

Appleby, M.C., B.O. Hughes and J.A. Mench (2004). **Poultry Behaviour and Welfare**. ISBN 08-5199-667-1, 288 pp.

FAO (2003). **Egg marketing. A guide for the production and sale of eggs**. FAO Agricultural services bulletin 150. Rome, Italy. ISBN 92-5-104932-7, 80 pp.

FAO (2004). **Newcastle Disease, with special emphasis on its effect on village chickens**. FAO Technology Review. Rome, Italy. ISBN 92-5-105080-5.

Gueye, E.F., (1999). **Ethnoveterinary medicine against poultry diseases in African villages**. World's Poultry Science Journal 55: 187-198.

IAEA, (2002). **Characteristics and Parameters of Family Poultry Production in Africa**. ISBN 90-5782-094-3. Vienna, Austria.

Lonsdale, C., (1992). **Straight. Raw materials for animal feed compounders and farmers.** Chalcombe publications, Marlow, UK.

Permin, A. and Hansen, J.W. (1998). **Epidemiology, diagnosis and control of poultry parasites.** FAO Animal Health Manual No. 4. ISBN 92-5-104215-2, 160 pp.

Riise, J.C., A. Permin, C.V. McAinsh and L. Frederiksen (2004) **Keeping Village Poultry. A technical manual on small-scale poultry production.** Network for Smallholder Poultry Development, Denmark (see Useful Addresses). ISBN 87-990401-0-7, 89 pp.

C.V. McAinsh and J.C. Riise, 2005. **Farmer Field Schools Facilitator's manual on small-scale village poultry production.** Network for Smallholder Poultry Development. ISBN 87-990401-2-3, 100 pp.

Sonaiya, E.B. and S.E.J. Swan (2004). **Manual - Technical guide on Small-scale Poultry Production.** FAO Animal Production and Health no. 1. ISBN 92-5-105082-1.

Also via : <http://www.fao.org/docrep/008/y5169e/y5169e00.htm>

Smith, A.J. (ed.) (rev. 2001) **Poultry.** The Tropical Agriculturalist, Macmillan London/Oxford. Co-published with CTA, Wageningen, The Netherlands. ISBN 0-333-79149-5, 242 pp.

Wethli, E. (1998). **The Southern African Chicken Book.** Juta Academic, 1998. ISBN 0-7021-4709-5, 104 pp.

Wethli, E. and H.A. Jensen (2005) **Chickens for Profit: Starting a Small Poultry Business.** ITDG Publishing, UK. ISBN 1-8533-9-59-5.

J. Wiseman (ed.) (1994). **Nutrition and Feeding of Poultry.** Nottingham University Press. ISBN 1-897676-52-2, 305 pp.

Internet sites

www.kyeemafoundation.org/irpc.php

International Rural Poultry Centre, Australia. IRPC is closely linked to ACIAR. IRPC has contacts in Ghana, Mozambique and Tanzania.

www.aciar.gov.au

Instruction manuals on chicken diseases can be downloaded from this Australian government website. Also vaccines against Newcastle Disease are available. Follow links: *our publications* > *ACIAR books online* > *animal health*.

www.fao.org/ag/againfo/subjects/en/infpd/home.html

INFPD is the International Network for Family Poultry Development of FAO.

Since 1997 INFPD produces two newsletters per year, covering all aspects of rural poultry development in the South. The Newsletter is sent electronically and is also available on-line, notably for African members, in English, French and Spanish. You can easily become a member of the INFPD and regularly receive the newsletter via:

<http://www.fao.org/ag/againfo/subjects/en/infpd/newsletters.html>

<http://www.aphis.usda.gov/vs/birdbiosecurity/>

Biosecurity for the Birds in a national campaign in the USA to promote avian health through biosecurity. Website hosted by USDA Animal and Plant Health Inspection Service (APHIS)

Useful addresses



PTC⁺ is an international training institute which focuses on all aspects of the production chain for plant and animal commodities, (agricultural) technology, (food) technology and nature protection and development. Training programmes are practice-oriented and mix theory with practical application. PTC⁺ offers 'open entry' programmes, 'tailor-made' programmes and consultancy. Programmes are offered in the Netherlands and/or at location.

It is the policy of PTC⁺ to search for partnerships and co-operation programmes with national and international institutions abroad.

PTC⁺ International Office

P.O. Box 64

3770 AB Barneveld

THE NETHERLANDS

T +31 342 406500

F +31 342 406501

E info@ptcplus.com

I www.ptcplus.com

Network for Smallholder Poultry Development

Dyrlægevej 2

DK1870 Frederiksberg

Copenhagen

DENMARK

T + 45 35 28 37 61

E poultry@kvl.dk

F + 45 35 28 37 62

I www.poultry.kvl.dk



The World's Poultry Science Association (WPSA)

Objectives of WPSA:

- To gather knowledge on all aspects of poultry science and the poultry industry and to bring this knowledge to the poultry industry, poultry scientists and other people interested in poultry.
- To bring together worldwide those concerned with all aspects of poultry science, poultry production and the many and diverse ancillary enterprises associated with the industry.
- To dedicate itself to the spread of knowledge so that education and training are ranked high amongst the interests of WPSA members.
- To promote good poultry husbandry.

What does membership of the WPSA provide?

- *World's Poultry Science Journal*, an informative bulletin also downloadable via : www.cabi-publishing.org/wpsj
- international poultry congresses, congresses and symposia of federations and branch meetings

World's Poultry Science Association - Secretariat:

Dr Ir. P.C.M. Simons

PO Box 31

7360 AA Beekbergen

T +31 55 506 3250

F +31 55 506 4858

THE NETHERLANDS

E piet.simons@wur.nl or wpsa@xs4all.nl

I <http://www.wpsa.com/>