



Strathmore
UNIVERSITY

Strathmore University
SU+ @ Strathmore
University Library

Electronic Theses and Dissertations

2017

Rapid discharge failure prediction model for solar charged lithium-ion batteries

Matthew Mutee Mutiso
Faculty of Information Technology (FIT)
Strathmore University

Follow this and additional works at <https://su-plus.strathmore.edu/handle/11071/5656>

Recommended Citation

Mutiso, M. M. (2017). *Rapid discharge failure prediction model for solar charged lithium-ion batteries*

(Thesis). Strathmore University. Retrieved from <http://su-plus.strathmore.edu/handle/11071/5656>

This Thesis - Open Access is brought to you for free and open access by DSpace @ Strathmore University. It has been accepted for inclusion in Electronic Theses and Dissertations by an authorized administrator of DSpace @ Strathmore University. For more information, please contact librarian@strathmore.edu

Rapid Discharge Failure Prediction Model for Solar Charged Lithium-Ion Batteries

Matthew Mutee Mutiso

Master of Science in Information Technology

2017

Rapid Discharge Failure Prediction Model for Solar Charged Lithium-Ion Batteries

Matthew Mutee Mutiso

084375

**Submitted in partial fulfilment of the requirements of the Degree of Master of Science in Information
Technology at Strathmore University**

Faculty of Information Technology

Strathmore University

Nairobi, Kenya

June, 2017

This thesis is available for use on the understanding that it is copyright material and that no quotation from thesis may be published without proper acknowledgement.

Declaration

I declare that this work has not been previously submitted and approved for the award of a degree by this or any other university. To the best of my knowledge the thesis contains no material previously published or written by another person except where due reference is made in the thesis itself.

© No part of this thesis may be reproduced without the permission of the author and Strathmore University.

..... [Name of Candidate]

..... [Signature]

..... [Date]

The thesis of Matthew Mutee has been reviewed and approved by the following:

Professor Ismail Ateya Lukandu, D. Sc.
Associate Professor - Faculty of Information Technology
Strathmore University

Dr. Joseph Orero (PhD)
Dean, Faculty of Information Technology
Strathmore University

Professor Ruth Kiraka
Dean, School of Graduate Studies
Strathmore University

Dedication

To Mercy and Maria; my young family, through you I have learnt what the words patience, persistence and planning really mean.

Acknowledgements

Many thanks to my Employer, M-KOPA solar for funding a part of this research. Special thanks to my mates in the masters class of 2017, we have all stood by each other to ensure no soldier is left behind. Last but not least to my supervisor Professor Ateya, he stood by me when all seemed lost. Thank you.

Abstract

Lithium-ion batteries are continually being deployed in many appliances. This is due to their high energy density and cost effectiveness. Most of these have been around for years in portable devices such as mobile phones. With the onset of smartphones, there is an ever increasing need to have batteries with superior performance. This can be viewed from the context of the need for fast charging and an ability to support a fully multitasked smartphone. Lithium-ion batteries have become the defacto battery type in many of these and similar applications due to their inherent characteristics. They have found use in not just mobile phones but also in innovative products designed to light homes as well provide for mobile phone charging in rural Africa. These products include a battery pack of Lithium-ion batteries cells charged by solar panels. There are a number of challenges facing the companies dealing with such products. There is a need to provide a superior product while at the same time ensure efficiency in the production line so as to bring down costs. All these need to be done while maintaining the elusive customer loyalty. One of the major issues faced is accelerated degradation which cannot be noticed using conventional approaches. Currently the main mode of triage for failure is visualization of graphs from data collected from the sensors attached to the batteries and observing for irregularities in the charge and discharging patterns. Existing literature talks about models used on linear data for forecasting in various fields of research. It also proposes an approach to predict battery life in batteries used on various applications such as hybrid electric vehicles. The proposed method will take advantage of predictive analytics in time series analysis to predict failure based on data from the batteries. Data from the batteries spanning 30 days was used to generate gradients of daily charging gradients. These were used as the training data with a binary class of faulty and good. We are able to train a model using the nearest neighbor algorithm to obtain over 80% accuracy with only a sample of 200 batteries data.

Table of contents

Declaration	i
Dedication	ii
Acknowledgements	iii
Abstract	iv
List of Tables	ix
List of figures	x
List of Equations	xi
Abbreviations/Acronyms	xii
Operational Definition of Terms	xiii
Chapter 1 : Introduction	1
1.1 Background of the study	1
1.2 Problem Statement	2
1.3 Research objectives	3
1.4 Research questions	4
1.5 Justification	5
1.6 Scope	5
1.7 Limitations	6
Chapter 2 : Literature Review	7
2.1 Introduction	7
2.2 Empirical Evidence Based on LiB	7
2.3 Challenges Facing LiB Production and Usage	9
2.4 Lithium-Ion Battery Operation	10
2.5 Failure Types In Li-Ion Batteries	11
2.6 Models/Frameworks For Failure Detection	13

2.7	Failure Detection In Lithium-Ion Batteries	14
2.8	Failure Prediction In Lithium-Ion Batteries	15
2.9	Conceptual Framework.....	19
Chapter 3 : Research methodology.....		21
3.1	Introduction	21
3.2	Research Design	21
3.3	Location of Study	23
3.4	Target Population and Sampling	23
3.5	Data Collection Procedures	24
3.6	Software Development Methodology.....	24
3.6.1	Systems Design.....	26
3.6.2	System Implementation.....	28
3.6.3	System Testing	28
3.6.4	System Evaluation/Validation.....	29
Chapter 4 : System Design and Architecture		30
4.1	Introduction	30
4.2	Requirements analysis	30
4.2.1	Functional requirements.....	30
4.2.2	Nonfunctional requirements.....	30
4.3	System architecture.....	31
4.4	Model Design	32
4.4.1	Use Case Diagram.....	32
4.4.2	Entity Relationship Diagram.....	34
4.4.3	Activity Diagram	35
4.4.4	System Sequence Diagram	37

4.4.5 Context Diagram.....	38
4.4.6 Level 0 DFD	39
Chapter 5 : Implementation and testing	41
5.1 Introduction	41
5.2 Implementation tools	41
5.3 Model Components.....	42
5.3.1 Data preprocessing Components.....	42
5.3.2 Step 1 linear regression.....	42
5.3.3 Step 2 Linear regression.....	43
5.4 Model Implementation	43
5.5 Model Training.....	44
5.6 Model testing	44
5.7 Acceptance testing.....	45
Chapter 6 : Discussions.....	47
6.1 Introduction	47
6.2 Model Validation.....	47
6.3 Error minimization	48
6.4 Confusion matrix	48
6.5 Model contributions to research	49
6.6 Shortcomings of the research	50
Chapter 7 : Conclusion and Recommendations	51
7.1 Conclusion	51
7.2 Recommendation	51
7.3 Suggestions for future research	52
References.....	53

APPENDIX A: Basics of Lithium-Ion Battery..... 57

APPENDIX B: Turnit in originality report..... 58

List of Tables

Table 3.2: Solid principles of object oriented programming	27
Table 5.1: Acceptance test cases and results	45
Table 6.1: Model Validation	48
Table 6.2: confusion Matrix.....	49

List of figures

Figure 2.1: The major components of lithium-ion batteries and their properties	7
Figure 2.2: Growth in Market Demand of Li-Ion Cells.....	8
Figure 2.3: Evolution of the production for Lithium-ion batteries by application	8
Figure 2.4: Cell surface temperature vs time of overcharge	12
Figure 2.5: Architecture of Echo State Network (ESN)	17
Figure 2.6: Real vs predicted values in SOC assessment	18
Figure 2.7: IoT Architecture	19
Figure 2.8: Failure prediction data flow	20
Figure 3.1: Design science research methodology	22
Figure 3.2: Spiral model of software development life cycle.....	26
Figure 4.1: System Architecture	31
Figure 4.2: Failure Prediction use case diagram.....	32
Figure 4.3: Failure Prediction Syst Entity Relationship Diagram	34
Figure 4.4: Prediction Activity Diagram	36
Figure 4.5: Manage Charging gradients System Sequence Diagram	37
Figure 4.6: Manage Tracked Batteries System Sequence Diagram.....	38
Figure 4.7: Analyze Charging Gradients System Sequence Diagram	38
Figure 4.8: Failure Prediction Model DFD Context Diagram	38
Figure 4.9: Failure Prediction Model Level 0 DFD.....	40
Figure 5.1: Battery Charging Cycle	43
Figure 5.2: Optimizing the charging curve	44

List of Equations

Equation 2.1: Naive Bayes conditional probability	20
---	----

Abbreviations/Acronyms

COB	–	Core, outlier, boundary
FDA	–	Fault detection and accommodation
GPRS	–	General packet radio services
GSM	–	Global system for mobile communication
IOT	–	Internet of things
LM	–	Levenberg-Marquardt algorithm
OC	–	Over charge
OSS	–	One-step secant backpropagation
PCA	–	Principal component analysis
SCG	–	Scaled conjugate gradient backpropagation
R&D	–	Research and development
LiB	–	Lithium-Ion Batteries
Ah	–	Ampere hours
SOH	–	State of health

Operational Definition of Terms

Thermal runaway

- Thermal runaway is loosely defines as a self-heating rate of 10C/min or grater. At this self-heating rate, it is highly unlikely that any intervention or external cooling mechanism could quench the ensuing process (Doughty & Roth, 2012).

Internet of things

- IoT refers to the networked interconnection of everyday objects, which are often equipped with ubiquitous intelligence (Vinel, Wang, Xia, & Yang, 2012).

Chapter 1 : Introduction

1.1 Background of the study

Sub-Saharan Africa has a huge potential for solar generated power. As a matter of fact, the whole of Africa has a potential for tapping into solar power generation. According to the international finance corporation, 6 of the world's sunniest countries are in Africa (International Finance Corporation, 2016). As a result of this abundant solar resource, many companies have noticed and come up with innovative business models around how to provide affordable solar power in many of these African countries. The target market is usually the people with no access to electricity: off-grid customers. This has led to almost cut throat competition and hence in order to maintain their various niches, customer service has to be exemplary. This is within the scope of offering competitive payment options, high-quality devices as well as superior after sales service.

The off-grid consumers are located at different geographical locations which also means different environmental conditions. Therefore it is important to ensure there is proper visibility of how batteries perform at various locations. Note that the solar intensity at various geographical locations is bound to be different. This ensures solutions are tailored to those specific conditions eventually improving not just the product but also the consumer loyalty. The success of an enterprise is highly linked to the loyalty of its consumers (Ma, Meng, Zhu, & Jun-Y, 2008). Further to this, consumer loyalty may be adversely affected especially when consumers are faced with failures in products and lack of after sales service (Luo, Han, Yu, & Wang, 2016). In the face stiff competition, it is paramount to keep performance at the very high and reduce the churn rate. With so many players pitching camp in East Africa with various products and services around the solar fields, brand loyalty will be an important aspect of gaining/maintaining market leadership.

The approach taken by the market leader in Kenya for the pay-as-you-go solar provider, M-KOPA has been using solar batteries fitted with GSM module. These modules allow for a means of communication between the batteries and the control center creating a massive internet of things network across all its areas of operation. At predefined intervals, the batteries will communicate via GPRS their status by sending a status notification which is usually the amount

of solar intensity in the area as detected by the panel, the charge on the battery contained in the device and the temperature as detected by the sensor placed within the battery. During normal operation, the batteries undergo a continuous cycle of charging and discharge. This operation is done within the context of different environmental conditions and customer specific unique behaviors. It has been noted that temperature is a good indicator of the performance of LiB in addition to affecting their lifetime. Research performed by (Ji, Wang, & Zhang, 2013) and (Leng, Tan, & Pecht, 2015) discuss the effects of temperature on the operation of LiB. Additionally (Belov & Yang, 2008) discuss some of the failure conditions that occur when the battery cells are overcharged. One of the major outcomes is thermal runaway which is basically a state of irreversible heating with devastating effects damaging the battery materials.

With all related historical usage data from the batteries available for some of the batteries which have failed before, coupled with an immediate business problem to keep consumer confidence high, then it forms a solid basis to try and understand how these factors correlate. Even most importantly find out how they can be used to provide early warning signals when they deviate from a known signature. The need is not simply to identify failure but to identify potential signs of failure early on before even consumers can notice a difference in the quality of the battery's daily operation. When these failures are noticed and actioned appropriately then it protects the businesses of negative brand perception from their consumers and in turn influences customer loyalty positively.

1.2 Problem Statement

In recent times, Samsung; an electronics company which has gained leadership in the smartphone market has been in the news for all the wrong reasons. 2016 saw the company receive negative media publicity for exploding batteries and washing machines. Samsung has had to recall the faulty devices for repair replacing most of them (Spence, 2016). The story of Samsung is synonymous with the stories of many companies that have gone to massive lengths spending billions so as to protect their brand perception. More importantly, it portrays some of the risks faced when rechargeable batteries fail.

The target organization sells its solar home systems which consist of a solar panel and a smart battery among other accessories to users in rural areas. Most of these users have no

alternative means of power leave for kerosene, therefore, a perfect scenario for them would be such that as long as there is sunlight, the battery charges properly and they can enjoy clean bright light at night. However, this is not the case for a considerably good number of the solar home system users. After a couple of months of usage, some of the batteries start failing unexpectedly. Based on the company's sales targets and a marketing plan highly depended on word of mouth referral it is paramount keep the existing customers happy through a superior after sales service. One of the ways this is done is through provision of warranty on accessories including the battery. The target is to ensure that potentially faulty batteries are swapped (within warranty constraints) long before the customer can complain of less than optimal performance. At the point of a complaint, there is a clear symptom where the batteries seem to charge too fast and discharge fast as well. Therefore it is in the best interest of the business to ensure that while production continually improves the quality of batteries produced, the subset of batteries likely to fail is identified as soon as they are deployed.

Environmental factors have a high impact on the performance of Lithium-ion batteries. The lifetime of a battery is greatly affected by the prevalent weather conditions. Hamilton and Pocock expound on this matter by outlining that temperature compounds the potential problems that batteries face. "The reliability and life of this type of battery technology will also decay exponentially if operated at elevated temperatures" (Hamilton & Pocock, 2006, p. 2). So considering such environment factors and patterns of usage we build a model based on machine learning techniques. This model enabled the prediction of future performance values for the batteries and as a result, enable a proactive means to predict the probability of failure over a given timeframe. This kind of insight is an important input in decisions affecting not just product development for the batteries but also consumer engagement.

1.3 Research objectives

- i. To review information around production and demand of lithium-Ion batteries.
- ii. To analyze challenges facing energy provision from lithium-Ion batteries.
- iii. To examine existing failure prediction approaches in lithium-Ion batteries.
- iv. To propose a model for use in predicting failure in solar charged lithium-Ion batteries.
- v. To test the model using data from the deployed batteries.

1.4 Research questions

- i. What type of information is available on lithium-Ion battery production and demand?
- ii. What challenges are faced in the energy provision from Lithium-Ion batteries?
- iii. What existing approaches are used for failure prediction in lithium-Ion batteries?
- iv. How can probability of failure in lithium-Ion batteries be predicted using charge patterns and battery cell temperature?
- v. How accurate is a generalized data model on historical data from deployed devices?

1.5 Justification

The outcome of this research will have profound effects by influencing customer interaction for the target organization. To begin with is the ability to provide superior customer perception with the guarantee of products that perform. This is quite important since the pay-as-you-go solar market is growing not just in Kenya but across Africa and therefore there is competition for consumers. One wrong move in terms of quality of service would easily see a customer going straight to a competitor.

Secondly, the outcome of the research will have a positive feedback loop to the battery production line on the quality of materials used and the methods used in manufacturing them. This will be quite important as it will mean the quality of batteries produced will be continually improved leading to fewer costs in replacements.

Thirdly, in a non-obvious way, the outcome of this research though focused on Li-ion battery data deals with streaming data from a general point of view. This means that the outcome is a ready solution that requires little or no configuration to handle data from a difference field where subtle variation from a known pattern needs to be detected. Therefore systems performance monitoring, financial markets, systems security, human vitals (pervasive computing) are all potential areas that can utilize the outcome of this research.

1.6 Scope

The research was performed using data from lithium ion batteries for customers of one company: M-KOPA solar. This is a financial services company that provides solar devices on a pay-as-you-go basis to off-grid customers. Once a device is registered into the system, it starts sending status data which includes location, temperature, current solar intensity as detected by the solar panel and current charge on the device's battery. Data was analyzed for individual batteries potentially grouped by geographical locations (since different locations will have varying environmental factors especially solar intensity). The analysis was limited to the point when the device was actually allocated to a customer so as to have data based on actual customer usage. The batteries which have been reported to fail for one reason or another were analyzed for failure patterns.

1.7 Limitations

The research limits the scope of research to just one company owing to the availability of data. This is greatly informed by the fact the company sponsors this research and therefore restricts research on company provided data. Time was a pertinent factor to consider and we were not be able to perform all the possible experimentation on the data. Therefore the model that worked with accuracy within a given margin of error was adopted and implemented.

The basis of this research is the various approaches to machine learning. Some of these approaches are quite expensive in terms of the computing resources they need. The funds available therefore will not allow using use of machines with large computing capabilities. As a result, this will have an impact on the speed with which we can achieve convergence with some of the machine learning approaches.

Chapter 2 : Literature Review

2.1 Introduction

Lithium-Ion batteries refer to a class of batteries where the negative electrode (anode) and positive electrode (cathode) materials serve as a host for the lithium-Ion (Li+) (Long, Kahn, Mikolajczak, & White, 2012). Lithium-Ions move from the anode to the cathode during discharge and are intercalated into (inserted into voids in the crystallographic structure of) the cathode. The ions reverse direction during charging. For the purposes of this research we will not be delving too deep into the chemistry around the composition of LiB but in subsequent sections talk about general compositions. The use of LiB has seen tremendous growth over the years due to various reasons. Some of these are based on their superior chemistry composition compared other battery chemistries such as lead acid batteries. The other one being mostly a natural change happening where most governments are attempting to cut down on greenhouse gas emissions.

2.2 Empirical Evidence Based on LiB

The selection of a specific composition for LiB would be based on factors such as application requirements, cost etc. The specific differences notwithstanding, the unique feature with these kind of batteries is the ability to provide high energy density coupled with a long life span. “lithium-ion batteries are featured by high energy density, high power density, long service life and environmental friendliness and thus have found wide application in the area of consumer electronics” (Han, Lu, Hua, & Ouyang, 2013, p. 272).

Name	LCO	LNO	NCA	NMC	LMO	LFP	LTO
Items	Lithium Cobalt Oxide	Lithium Nickel Oxide	Lithium Nickel Cobalt Aluminium Oxide	Lithium Nickel, Manganese Cobalt Oxide	Lithium Manganese Spinel	Lithium Iron Phosphate	Lithium Titanate
Cathode	LiCoO ₂	LiNiO ₂	Li(Ni _{0,85} Co _{0,1} Al _{0,05})O ₂	Li(Ni _{0,33} Mn _{0,3} Co _{0,33})O ₂	LiMn ₂ O ₄	LiFePO ₄	e.g.: LMO, NCA, ...
Anode	Graphite	Graphite	Graphite	Graphite	Graphite	Graphite	Li ₄ Ti ₅ O ₁₂
Cell voltage	3,7 - 3,9V	3,6V	3,65V	3,8 - 4,0V	4,0V	3,3V	2,3 – 2,5V
Energy density	150mAh /g	150Wh/kg	130Wh/kg	170Wh/kg	120Wh/kg	130Wh/kg	85Wh/kg
Power	+	o	+	o	+	+	++
Safety	-	o	o	o	+	++	++
Lifetime	-	o	+	o	o	+	+++
Cost	--	+	o	o	+	+	o

Figure 2.1: The major components of lithium-ion batteries and their properties (adopted from Recharge, 2013, p. 8)

Figure 2.1 provides an overview of some of the chemical compositions for Lithium family of batteries. Due to the wide applicability of the batteries, the market has been very receptive to their production and this has seen a continuous growth curve. This growth is predicted to be the trend in the foreseeable future (3 years) as shown in Figures 2.2 and 2.3.

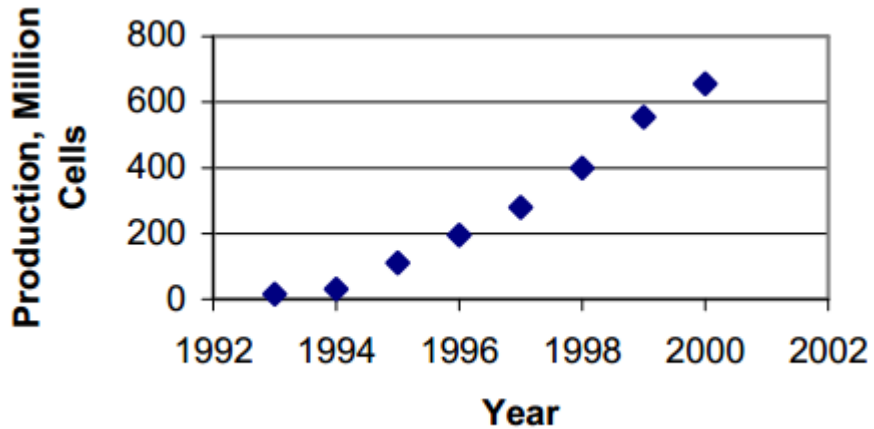

Figure 2.2: Growth in Market Demand of Li-Ion Cells (adopted from Brodd, 2013, p. 1)

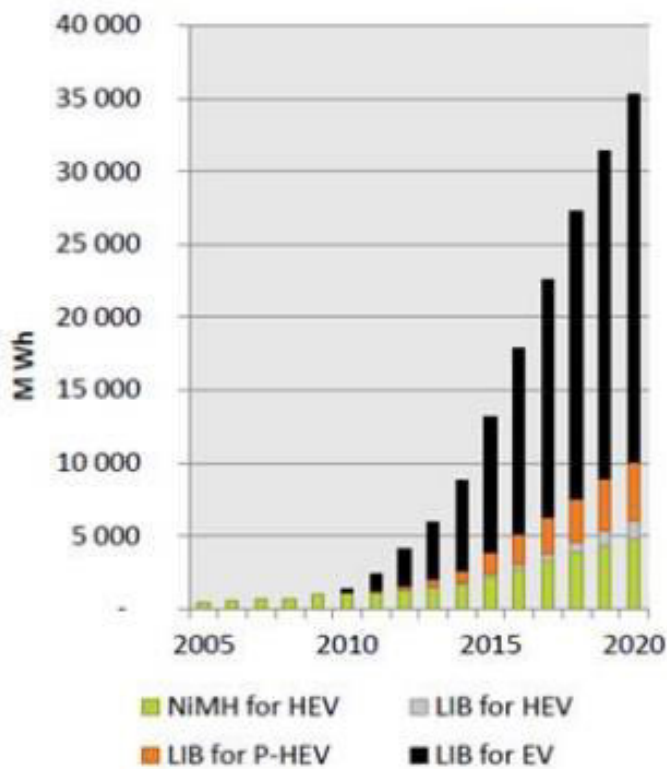

Figure 2.3: Evolution of the production for Lithium-ion batteries by application (adopted from Recharge, 2013, p. 5)

Even with this growth the components used to manufacture Lithium-Ion batteries have a room for improvement and this is continuously being done with R&D active in identifying new carbons to replace the original hard carbon anode (Brodd, 2013). “In order to make sure that the operation of Lithium-ion battery-powered devices and systems are safe, reliable and economic, it is very important to predict life and other key performances for Lithium-ion batteries” (Haodong, Hongzheng , Huanzhen , & Hui , 2015, p. 1). Therefore the features mentioned portray an opportunity at improving the performance of the batteries beyond current capacities while at the same time ensuring the durability of the devices they power. This however has to be determined via a data driven approach through the analysis of the data available from the batteries. Collection of the data means placing of sensors within the batteries and possibly a communication module hence adopting an internet of things architecture. Therefore proper design of the IOT module has to be incorporated in the overall device design so as to ensure the battery’s power is not spent up powering the communications module.

2.3 Challenges Facing LiB Production and Usage

The improvement of LiB usage is still an active area of research. This is necessitated by the fact that despite the overall advantages over other battery types, the available compositions are still not as cognizant of the current needs. The current needs are majorly a growing need for power in both developed and developing countries as well as a need to provide clean energy. As a result of this requirement we are seeing more and more integrations with power stores. The challenge with the integration is generally finding an efficient way of doing so a case in point being it leads to the power surges in the areas where grid power is low. Integration of renewable energy sources into grids at remote points, where the grid is weak may generate unacceptable voltage variations due to power fluctuations (Hamsic, Mohd, Ortjohann, & Schmelter, 2008).

When it comes to the basics of the batteries a number of factors need to be considered to ensure that battery performance is optimal. These points as pointed out by (Choi & Patil, 2006) place some specific requirements on the materials used to make the batteries. They are thin film compact and light weight, no heavy metal housing and modular, can be made in variety of design and size, excellent reliability, inherently safe, high cycle time and high energy capacity, low cost

and wide temperature range, 1% energy loss / year, a high power density and high discharge voltage, no memory effect and do not use poisonous metals, such as lead, mercury or cadmium.

All these requirements present a challenge to the successful design of battery of the battery pack. While the current energy density is still high, there is need to increase more to reduce the use of fossil fuels. The proposed research is concerned about the energy loss of these batteries over time. Increasing the energy density is still a major challenge as gasoline still outperforms LiB in terms of energy content. Research by (Tarascon, 2010, p. 3228) points out that there is a need to increase the energy density by a whopping 15% in order to match gasoline. “Knowing that the energy density of batteries has only increased by a five over the last two centuries, our chances to have a 10-fold increase next few years are very slim, with the exception of unexpected research breakthroughs” (Tarascon, 2010, p. 3228).

Lowering the cost is also a major challenge in LiB battery production and usage. At the moment Lithium the metal comes from brines which are mainly located in Chile and Bolivia. With the increased demand there is a risk a risk that in the not so distant future the Lithium could be depleted. It is also found in unlimited quantities in sea water but the extraction is expensive and much trickier than from brines (Tarascon, 2010, p. 3235). There are a whole host of other challenges that befall the design and use of LiB including safety during which have made the domain still and active area of research.

2.4 Lithium-Ion Battery Operation

The use LiB has is widespread in many industries. But what data is available on how they perform under different conditions? For the basic chemistry of Lithium-Ion batteries, see Appendix A. However some of the areas documented include how temperature affects their performance. (Leng, Tan, & Pecht, 2015) Conclude that at a higher temperature over the room temperature but under 55 degrees Celcius, there is a large charge storage capacity. This however is only a short term gain which has the demerit of increasing the degradation data of the charge storage capacity. This is caused by irreversible capacity loss accelerated by elevated temperature (Leng, Tan, & Pecht, 2015). We notice that temperature either in a mild form will cause the effects just discussed and at extreme cases lead to the phenomenon termed to as thermal runaway. This happens when the temperature exceeds a certain thresholds as caused by a range of factors such as thermal abuse (Doughty & Roth, 2012).

Low temperature also have the reverse effect of controlled high temperature as they lead to low reduced energy and power densities at low temperatures. “It is generally believed that the poor performance of Li-ion cells at low temperatures are associated with: poor electrolyte conductivity, sluggish kinetics of charge transfer, increased resistance of solid electrolyte interphase (SEI), and slow Li diffusion through the surface layers and through the bulk of active material particles” (Ji, Wang, & Zhang, 2013). For any of these temperature conditions it calls for an understanding of the underlying materials so as to recommend the optimal operating temperature.

2.5 Failure Types In Li-Ion Batteries

All batteries have a period within which performance degrades continually. As for the case of lithium-Ion batteries there are conditions which lead to this degradation happening at exponential rates. Basically leading to failure of the devices they power. There are various types of failure that a battery might undergo of course all caused by various reasons which could range from environmental to use (or abuse). Some of the failure types include thermal abuse. (Doughty & Roth, 2012, p. 38) Highlight short circuit as one of the reasons a cell within a li-ion battery will heat up causing what is referred to as Joule heating. “Over charge can also generate heat within the cell due to other oxidative chemical reactions that can trigger thermal runaway” (Doughty & Roth, 2012, p. 38).

Other failure types include physical damage which are as a result of vibration, crush, puncture and shock also charge and discharge failures. As for the case of discharge failure this is caused by charge going beyond given extremes from both the high and low ends. “The response of cells and battery packs during overcharge depends on overcharge parameters (current, maximum voltage), thermal environment, and cell materials and is a complex function of several failure mechanisms” (Doughty & Roth, 2012, p. 38). The work by Doughty and Roth highlights some of the issues that Lithium-Ion batteries may have. The part that we appreciate is that point where they bring out how the effect of overcharging and over discharging lead to battery failure. Most importantly this forms the basis of this research since they show that it is possible to detect failure from the pattern of battery charge. It is observed that most of the failures of the batteries is caused by overheating. (Belov & Yang, 2008, p. 887) Perform a test to simulate overheating.

They record the current-temperature data every 5 seconds during overcharge as shown in figure 2.4. In addition to battery charge and discharge pattern. Temperature serves as a good indicator of failure as temperature beyond a certain threshold are usually and indicator of thermal runaway.

The only concern with the use of internal temperature as measure of failure especially with machine learning methods will be the fact that the temperatures might actually be different for similar condition applied to the batteries. “Every cell in each series of experiment has a different behavior, i.e., maximum cell temperature may have some difference for each single cell because of slightly different assemblage and cell quality” (Belov & Yang, 2008, p. 887). In case of parameterized model where a global maxima has already been established then using temperature may have mixed result.

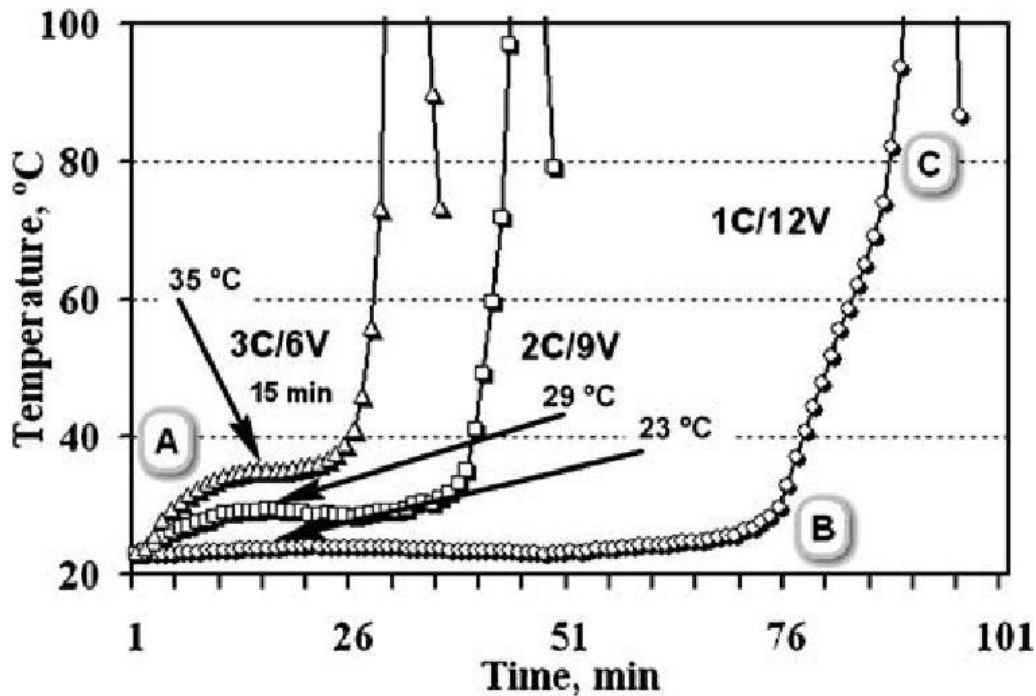

Figure 2.4: Cell surface temperature vs time of overcharge (adopted from Belov & Yang, 2008, p. 888)

Therefore since we cannot overlook the fact that the battery cells are different then we will lean towards the machine learning approaches which can find a local approximation of the hypothesis. Another approach would be to set a margin of error where we expect the temperature range to fall within. This can be compared to the margin of a linear classifier in a very basic linear support vector machine.

(Hamilton & Pocock, 2006, p. 2) Also mention thermal run away as a failure more in lead acid batteries. In their discussion they propose a battery impedance monitoring system which will help monitor the cells condition and help to avoid the sudden death fail. Monitoring system a reactive approach since action is only bound to be taken when/if an issue is detected. This can however be used in conjunction with a battery management system, as mentioned by (Hamilton & Pocock, 2006, p. 2), which can keep the charge level within constraints and prevent thermal runaway.

2.6 Models/Frameworks For Failure Detection

Detection as well as prediction of faults in multiple appliances boils down to real-time analysis of sensor data. Should a fault be detected then an appropriate action can be taken. (Apley & Shi, 1994, p. 2633) Use a generalized likelihood ratio test (GLRT) for fault detection in multiple input single output (MISO) systems. A GLRT, as opposed to a likelihood ratio test (LRT), is used because the fault magnitude is unknown and must be estimated from the data (Apley & Shi, 1994, p. 2633) . This approach starts by formalizing the detection problem by defining the statistical hypotheses to be tested. The hypotheses are then generalized using the approach given. That is instead of testing for fault that have occurred at all previous times, only fault occurring in the interval $\{t-N, t-N+1, \dots, t\}$ will be tested for where t is the current time and $N+1$ is the window length. N is selected considering computation complexity and probability of detection.

The definition of defining hypotheses then generalizing to the most general is a good approach especially if we don't have noise in the training data. This will ensure that the version space is reduced to the most general hypothesis when N is given. It however introduces a challenge when multi parameter input data contains noise and the final hypothesis has to overfit. Therefore the main challenge with this approach that would need improvement is how to accurately determine the value of N .

Kwan et al propose a software algorithm for analyzing sensor signal using principal component analysis, learning vector quantization and hidden markov models (Kwan, Zhang, Xu, & Haynes, 2003, p. 605). The PCA is said to significantly reduce the dimension of the input data. The LVQ is used to generate a sequence of codes which are used by the Markov model. The Markov model classifier is used for performing fault prognosis and diagnosis. The conceptual design of this system is quite powerful as it conforms to the separation of concerns principal of software engineering principles. It means that the classifier can be trained on data that is confirmed to relevant. This is especially important if the sensor data streaming in has high dimensionality and only few feature of each instance are needed to learn a model. The approach does not however factor in feedback from new instance during classification. In a dynamic environment where conditions vary then a machine learner should be able to tune its parameters based on new instances encountered.

In other material fault detection is referred to as Fault detection and accommodation (FDA). (Polycarpou, 1994, p. 1723) Provides a formulation for an estimated model which is a continually updated mathematical representation of the physical system. “To detect any changes in the system dynamics, the estimated model is compared to a nominal system model. Residual generation gives a measure of the deviation between the estimated and the nominal model. This measure can be expressed in terms of the system outputs, the state variables, some critical system parameters, or, more generally, a combination of the above” (Polycarpou, 1994, p. 1722).

All the sources reviewed in this section from general perspective use a parameterized approached backed by some form of machine learning technique usually linear regression. The learned classifier is used to predict the deviation from a given pattern in the data whose origin is sensors. Each of them have been identified to have a shortcoming.

2.7 Failure Detection In Lithium-Ion Batteries

Failure in Lithium-Ion batteries has been an active area of research in recent past. In the previous section the material reviewed explored some of the failure types that might occur in lithium-Ion batteries. The detection of faults especially early on before the onset of thermal runaway is paramount to the safety of the user and also cost implications since an explosion of the battery has probability of causing damage to the entire device.

Prior literature has considered a general approach to failure detection. When considering the specific subject of failure in Li-Ion batteries, (Anwar, Izadian, & Sidhu, 2015, p. 1005) model parameters for failure for both overcharge and over discharge separately. The OC failure of battery cells can be attributed to a combination of factors, such as excessive temperature, along with cell construction and design (Anwar, Izadian, & Sidhu, 2015, p. 1005). Therefore this distinction is important as it improves the accuracy of the models due to the different factors that lead to failure in both cases. In fault detection their system designed to accurately represent n signature faults. One input signal is used to activate all the models simultaneously. However each model generates an exclusive output. This approach is good as it allows for independent models which can actually be plugged in and tuned differently.

2.8 Failure Prediction In Lithium-Ion Batteries

While section 2.7 reviews the just-in-time detection of faults in a lithium-Ion battery, the basic objective of this research is to provide an ability to predict imminent faults before they happen. In battery management systems, two indices are used to indicate the current state of a battery. These are the state-of-charge (SOC), which is quantified as the percentage of charge remaining in a battery before recharging, given the current cycle. The other is state of health (SOH), which is a figure of merit indicating the remaining useful life (RUL) of a battery (Xing, Ma, Tsui, & Petch, 2012, p. 1). Therefore for manufactures, the maximum charge a battery is able to deliver is a major criterion of the health of a battery and by extension a contributing factor of the quality of service of the device the battery powers. Most devices which use rechargeable batteries have a limited lifetime. Most manufactures of these devices and batteries will hope the same lifetime or the batteries perform as they performed when the devices were new but this is not the case.

When it comes to the state of health of a battery there are various parameters which are used. The parameters include increase in cell resistance, variance of AC impedance, and decrease in capacity and power, while capacity is usually viewed as the major indicator for the battery health estimation (Xing, Ma, Tsui, & Petch, 2012, p. 2). One of the approaches of state of health evaluation is use of what is terms as physics-of-failure which uses knowledge of the product's life cycle loading, structures, material properties and failure mechanisms to estimate remaining

life. This approach of determining the state of health presents with a limitation as this research proposes the use of analytical approaches based on data from the sensors attached to the battery.

In order to provide a value proposition in fault diagnosis, a plug and play approach is needed to determine state of health. By using a data-driven approach Xing et al model a capacity curve was where the SOH is estimated through a polynomial regression. A history-based algorithm and time-window algorithm were developed for SOH estimation. The approach use recursive Bayesian filtering which is a generic approach to estimate the posterior expectation and posterior probability density function (pdt) based on observed data. Prediction and update are the two steps to process the filtering. First, the state is predicted with the probability density one-step ahead of the system model. Then, the current measurement will be used to modify the predictive result and determine the estimation of the current final state (Xing, Ma, Tsui, & Petch, 2012).

The use of a data driven approach is also applied by (Liu, Xie, & Peng, 2015). Using a data driven approach allows for the assessment and reliability estimation based only on testing data samples and monitoring parameters. Therefore the models will ignore the complex electrochemical reaction and the related principles (Liu, Xie, & Peng, 2015). While this a perfect fit to the approach this research proposes it is a limitation that we will be willing to accept based on the present constraints. Liu et al propose a probability-based integration strategy for the ensemble of sub models that exerts the strongly nonlinear prediction capability of MONESN (monotonic echo state networks) model and enables uncertainty quantification beyond the capability of basic ensemble learning algorithm.

Monotonic echo state networks are derived from recurrent neural networks (RNN). Generally a RNN can be used to approximate any dynamic system with a given precision, but training difficulty often pose limit to its application and hence Liu et all describe the variations of RNN into MOSESN.

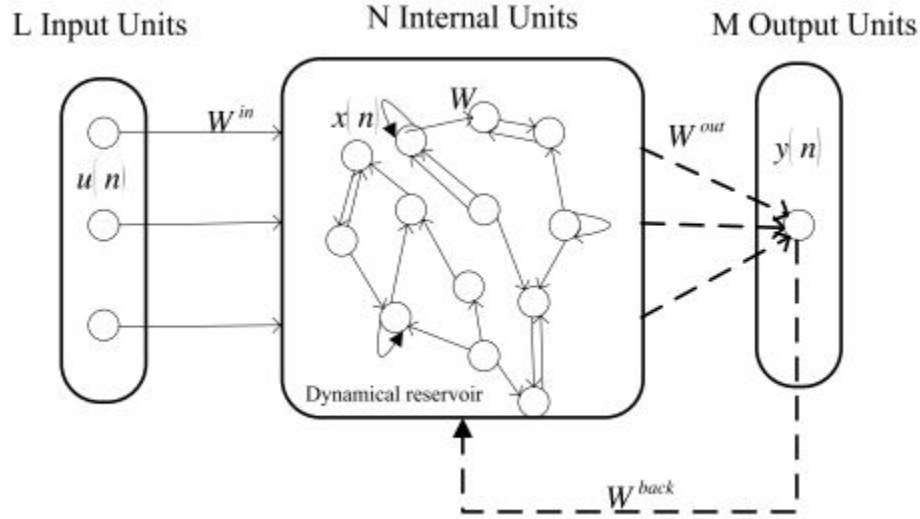

Figure 2.5: Architecture of Echo State Network (ESN) (adopted from Liu, Xie, & Peng, 2015)

A discrete ESN has an L-dimensional input unit, an N -dimensional internal processing unit, and an M -dimensional output unit. At a time instant k, the input unit, the internal processing unit, and the output unit are expressed as

$$u(k) = (u_1(k), \dots, u_L(k)), x(k) = (x_1(k), \dots, x_N(k)), y(k) = (y_1(k), \dots, y_M(k))$$

Respectively. ESN have a good memory property as it adopts the dynamic reserve that contains a large number of sparsely connected neurons. This algorithm provides the advantage of simplifying the training process and in a state of chaotic time series prediction, the prediction accuracy is 2400 times better than that of traditional RNN (Liu, Xie, & Peng, 2015).

For online appliances, trying to predict failure may not work purely by using state of charge may not work as the batteries never really charge to 100% or discharge to 0%. They are constantly in use the cycles are also continuous. A different approach to predict failure is through predicting the next sensor value. Pertinent to the proposed research is the next battery charge value based on the charging/discharging cycle. (Chunhua, Ren, Runcai, & Jianbo, 2012) Use a radial basis function neural network which has three feedforward neural networks. Input layer has three input values which are outputs from the original and redundant sensors and data fusion respectively. The hidden layer is radial basis function. Only an output value is from output layer. The weighed factor from input layer to hidden layer is supposed to be 1. The weighed factor from the hidden layer to output layer can be modified. This approach supports a human

reinforcement in the decision making where it is possible to illustrate both the expected and observed values as is the case temperature values from a sensor as shown in figure 2.6.

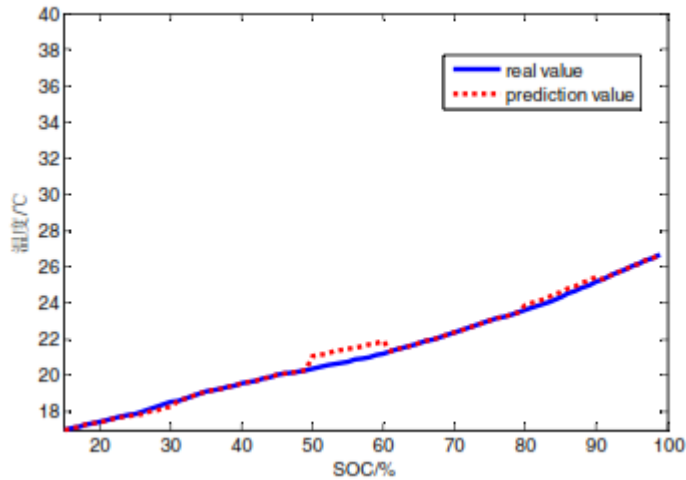

Figure 2.6: Real vs predicted values in SOC assessment (adopted from Chunhua, Ren, Runcai, & Jianbo, 2012)

When using a data driven model based on data from sensors, there is an inevitable possibility that the signals will have noise. Particle filter can be used to solve the nonlinear mechanical system fault prediction and estimation problem. The idea of particle filter is to generate a set of random sample collection in the state space based on empirical condition distribution of system state vectors. These samples are called particles. Then continuously adjust the weights and locations of the particles according to measurement. When sample size is large, this Monte Carlo description is similar to the posterior probability density function of the actual state variables. Fang et al Use this premise for prediction of failure in the batteries based on prior observances. “For the prediction of target degradation state, it is important to manage the uncertainty of future states. But on the premise of having no observation of future states, we can only make the simulation on future states through the use of the existing prior knowledge (including degradation model, observed data, etc.)” (Fang, Fan, Ma, Shi, & Dong, 2015, p. 2)

The work reviewed converges on the use of a data driven approach to approximate failure in Lithium-Ion batteries. Though they use various machine analytical models, they are all based on predicting the next value in a signal and an attempt to determine if it conforms to expected outcome. This is the general approach to be used in the proposed research as it provides a solid

ground from predicting failure based on the features of the battery data available for this research.

2.9 Conceptual Framework

The overall system architecture adopts the internet of things approach. Since this implementation is already in place and data is available what lacks is the failure prediction module. This research focused on making use of the massive data already in existence to predict failures early on before they can be discovered by a human analyst.

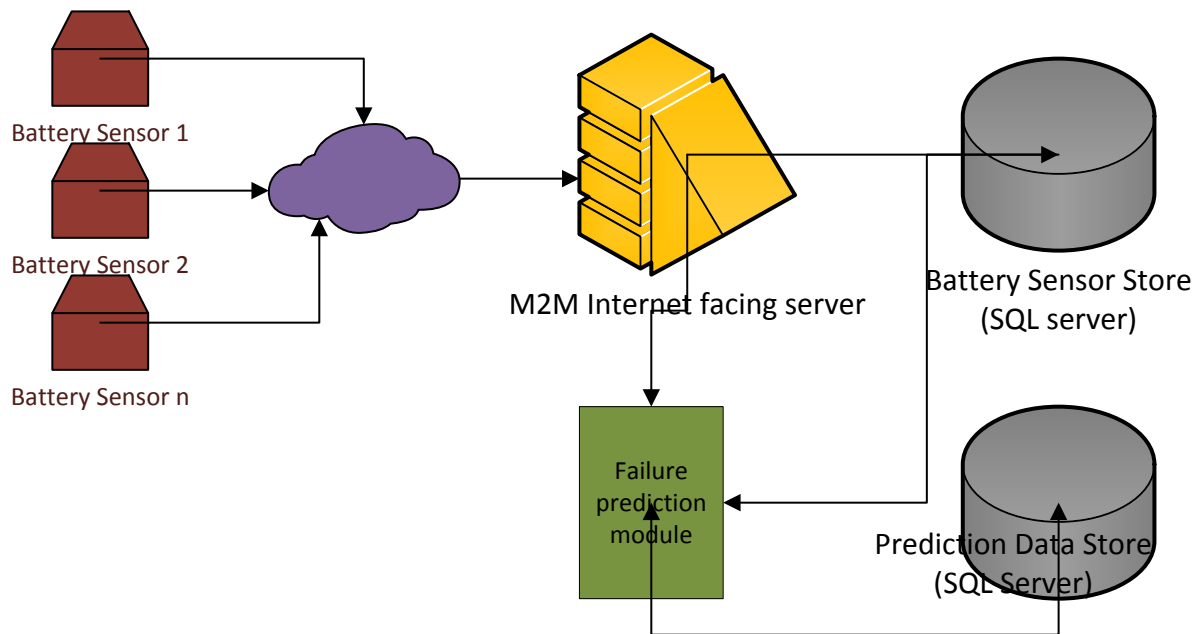

Figure 2.7: IoT Architecture

Prediction of failure was done using a time series analysis approach with a combination of linear regression and nearest neighbor for signature comparison. The diagram below outlines the flow data in an attempt to predict failure from the sensor values.

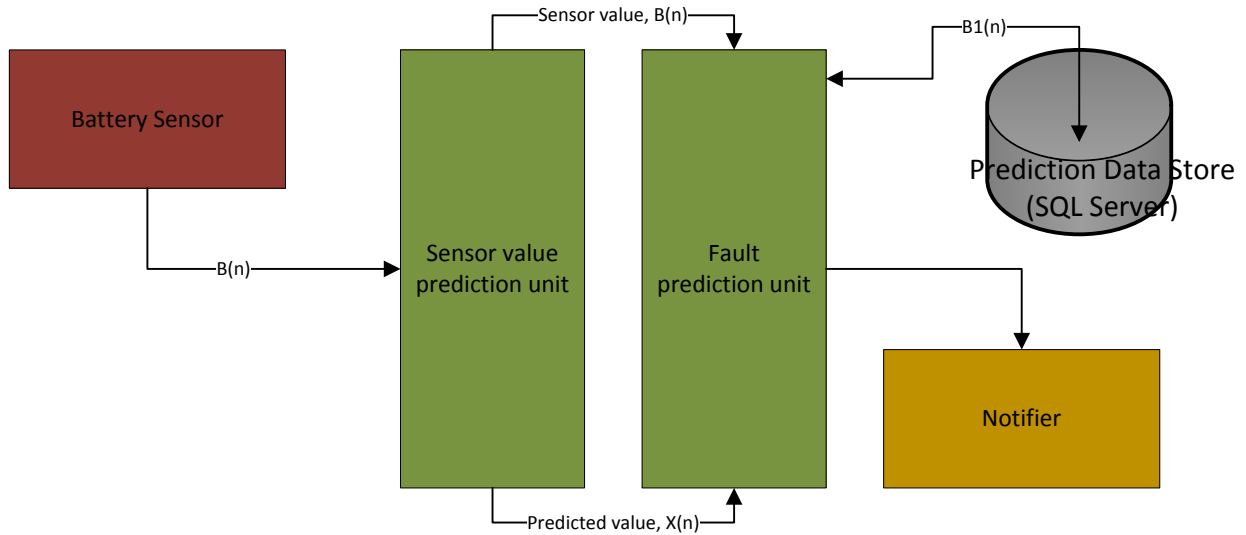

Figure 2.8: Failure prediction data flow

B(n) represents the outputs from the battery sensor and input into the sensor value prediction unit. These are the battery charge and temperature together with the corresponding timestamps they were generated. The sensor value prediction unit attempt to provide the probable values with a considerable margin of error given the current values. **X(n)** is therefore the predicted value which now together with **B(n)** will be used by the fault prediction unit. When a fault is probable, this will be raise via the “Notifier” module. Training data will be continually updated from the output of the fault prediction unit. This borrows heavily from naïve Bayes machine learning approach where a classification affects the probability of new instance falling in a given class.

Generally this will affect the probability consistent with the equation

Equation 2.1: Naive Bayes conditional probability

$$posterior = \frac{prior \times likelihood}{evidence}$$

Chapter 3 : Research methodology

3.1 Introduction

The research was structured consistent with the research objectives as outlined in section 1.3. The literature review answers questions 1-3 and so this methodology will endeavor to explain the plan that was used to guide the set of tasks that were performed in order to answer the rest of the 2 questions. Figure 2.5 shows a sample IoT architecture with intelligence part being on the backend of all “things”, that is the whole range of batteries that have been deployed. The research endeavored to carefully select the historical data as labelled from business operations data stores to obtain both training and test data. Further to this study, software engineering approaches for building resilient distributed applications with the ability to perform at scale were applied. The rationale for proposing the various approaches is discussed subsequent sections in the chapter and were adopted to ensure that the main deliverable from this research is a system which can continuously learn from incoming data and proactively inform which device batteries are likely to fail at a point in the future.

3.2 Research Design

A variant of design science research methodology (DSRM) was used to guide the stages of the research. The major objective of design science research as outlined by (Azasoo & Boateng, 2015) is to solve a problem by creating an artifact, that is new and relevant design knowledge in the context of research. (Omar, Trigunarsyah, & Wong, 2009) Reinforce this definition by expounding that the main objective of DSRM as extending the boundaries of human and organizational capabilities by creating new and innovative artifacts. Therefore design science performs the research by building and evaluating artifacts to address the management problems hence Figure 3.1 was applied with slight variations to incorporate behavioral science methodology. This variation is identified to fix the main shortcoming of the DSRM methodology where it fails to show the underlying research that will guide the development and communication of the stated artifacts.

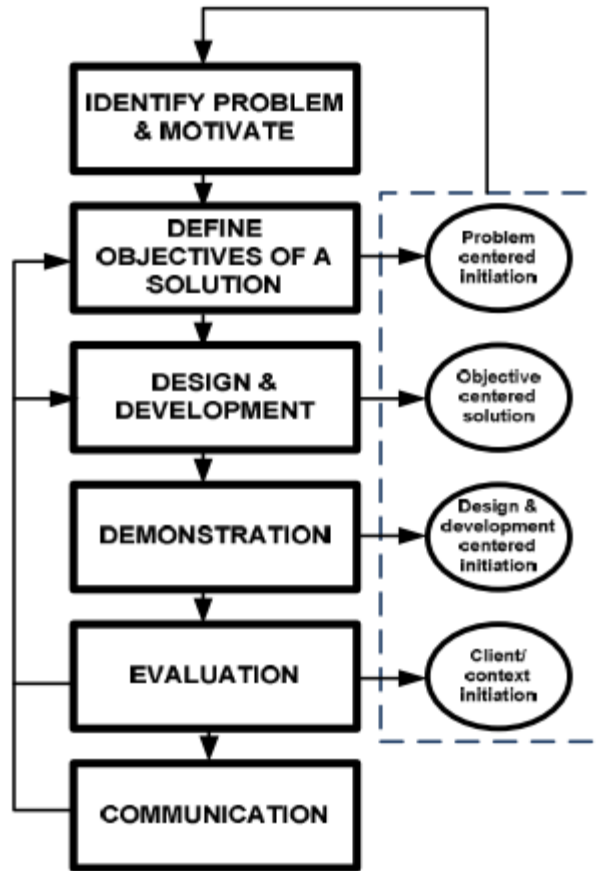

Figure 3.1: Design science research methodology (adopted from Azasoo & Boateng, 2015)

As part of the development phase of the design science research methodology the research proposes a background/daemon worker process that will be continuously be working on sensor data calculating the probability of failure for each of the given batteries. At the core is a model that generalizes the test data from previously failed batteries while at the same time ensuring that it doesn't over fit. We have also demonstrate the performance of batteries using graphs showing what current charging values are and what they ought to be on a happy path.

The test data to build the model was collected from the business operational store and the details with regard to how it was be sampled will be handled in the target population and sampling section. Based on the features in the data, a number of steps were performed to make it learning algorithm ready. (Witten & Frank, 2005) Mention some of the steps that need to be performed in order to prepare data for a machine learning task. In addition it is mentioned that

60% of a data mining project is consumed during preprocessing which will involve performing some or all of these given below.

- i. Data discretization – for continuous values like age or time of day
- ii. Data cleaning – filling in missing values, smooth noisy data, identification and removal of outliers and resolving inconsistencies.
- iii. Data integration – from multiple databases such as the IoT backend and business operational data.
- iv. Data transformation – normalization and aggregation
- v. Data reduction – provide a reduced representation in volume with similar analytic results.

3.3 Location of Study

There is a growing use of LiB batteries in various appliances especially in the field of solar powered appliances. Therefore this study has a lot potential areas in which it can find potentially useful data for analysis to achieve intended objectives. However, so as to be consisted with the scope and limitations outlined in section 1.7 and 1.8 respectively the study was conducted on historical data from batteries in devices sold by M-KOPA solar between 2013 and 2015. The historical data represents devices that are both good and those that eventually failed with rapid discharge. This provided for a large enough dataset to allow a sufficiently generalized model to use in the prediction of failure as the conditions battery production have fairly remained similar.

3.4 Target Population and Sampling

A random sample was selected from the labelled batteries that show a history of having been allocated and had batteries replaced for one reason or another. At the time of writing this research, the target company operates in 4 countries, 3 in East Africa and 1 in West Africa. The research focused on incidents reported only in Kenya and specifically those confirmed to have experienced battery failure as the devices could have failed owing to a whole range of other reasons. Therefore the triage process was thoroughly examined to ensure that only confirmed

battery failure is the primary basis of selection. With regards to sampling, random sampling approach was used.

3.5 Data Collection Procedures

The research is unique in that it is based on historical data. It is the first attempt to deal with the common problem of massive data lying in corporates databased but mostly goes unanalyzed. In a poll of 300 government workers the poll suggests an unacceptable lag time between when malicious actors infiltrate a system and when they are typically discovered, which only then sets in motion the process of trying to close the vulnerability and assess and mitigate the damage. There exists gaps with the time when incidents occur and when they actually get discovered as outline by (Corbin, 2016). This is an increasingly worrying trend as data continuously gets produced and lies in situ. Hence analytics need to catch up not just in terms of security as mentioned by Corbin but also in all spheres of the business in tandem with the overall business strategy.

Therefore the research build a model based on the historical data that was used to process sensor data in real-time and as a result critical business input from various domain experts was sought. Below are some of the data collection methods that were used.

- i. Personal interview – Was used to capture in detail the process taken to triage an issue with batteries. Provided a clear idea of techniques and approaches the domain experts have used before.
- ii. Questionnaire - With limited time and resources to exhaustively approach enough number of experts, this approach implemented via online tools was useful to support parallelism in collection of results as well automate the data analysis.

3.6 Software Development Methodology

The main artifact according to the design science methodology is a background service that continuously runs. It receives alerts from the main IoT backend system and process the messages asynchronously. That is, all data will be persisted then an independent message will be published through the asynchronous message queuing protocol which will be consumed by the

background service. However since this research deals with potentially confidential data, exclusive permission may not be granted to plug into the IoT backend while still doing the research. Therefore from the extracted data, we created python scripts which emit graphs to illustrate batteries during different stages in the charging cycles and their probability of failure in real-time.

Therefore, as a result the agile software methodology was used based on small time boxed iterations of 2 weeks to deliver potentially reviewable and operable features of the main system. Figure 3.1 shows the approach through a spiral model which allows for incremental gains from a very early stage of the research. During the first days the tasks were concentrated on machine learning tasks but as the spiral grew large the software development aspects were introduced.

Specifically, the research provides numerous prototypes which can be updated. During the early cycles of the spiral, the prototypes especially not pay heed to how well the implementation utilizes machine resources such as CPU and memory. The focus is getting the most out of the training data to get a model that works while minimizing the error rate. During the later cycles focus shifts to optimizing for performance; that is payment of the technical debt incurred. All this happens with a version of the research document being produced. The document was updated based on the feedback from the supervisor.

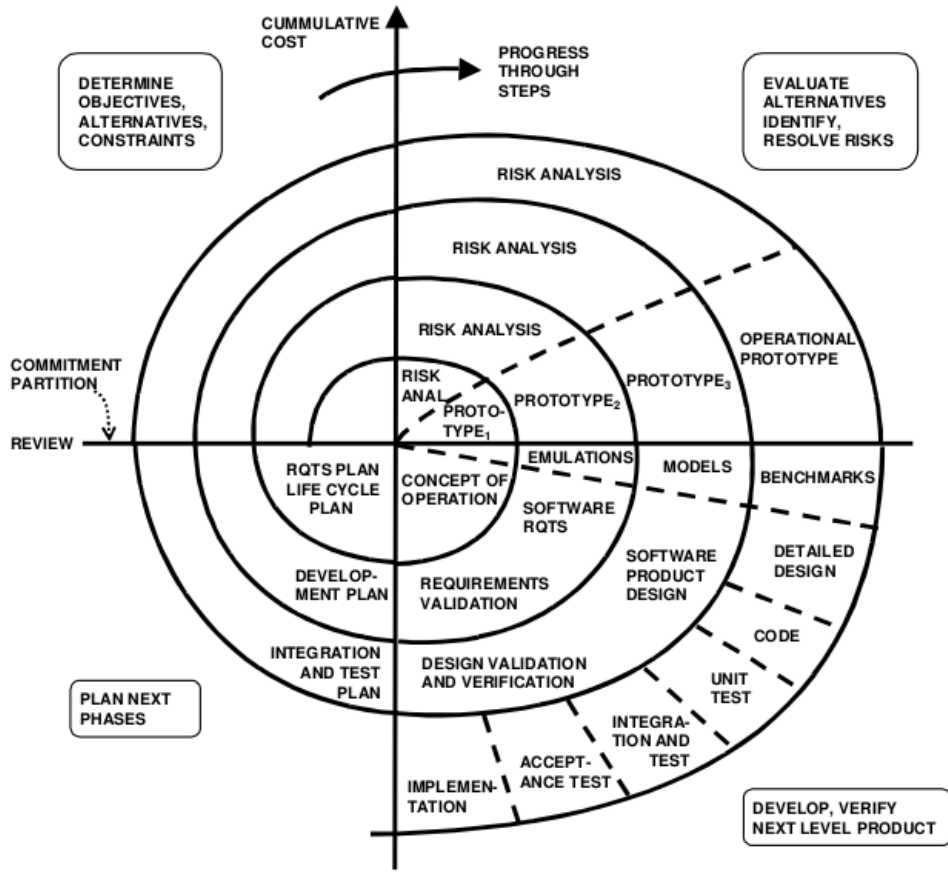

Figure 3.2: Spiral model of software development life cycle

3.6.1 Systems Design

The outcome of the research activity was to build a prototype as explained in section 3.6 (software methodology). This prototype was largely used as a proof of concept based on the data model whose confusion matrix is the critical success factor for the research. The design however assumes a fully-fledged system designed to integrate into the business as usual operations for the company who's this research is constrained to. As a result a number of software modelling tools are used in the design of that system. The design diagrams produced have major leanings into the object oriented design methodologies as a result of the robustness they give to applications designed due to the five principles acronymed SOLID. These principles were pioneered by American software engineer, author and public speaker Robert Cecil Martin. They are expounded in table 3.2.

Table 3.1: Solid principles of object oriented programming

Principle	Description
Single responsibility principle	A class should have one and only one reason to change, meaning that a class should have only one job
Open closed principle	Objects or entities should be open for extension, but closed for modification
Liskov substitution principle	Let $q(x)$ be a property provable about objects of x of type T . Then $q(y)$ should be provable for objects y of type S where S is a subtype of T
Interface segregation principle	A client should never be forced to implement an interface that it doesn't use or clients shouldn't be forced to depend on methods they do not use.
Dependency inversion principle	Entities must depend on abstractions not on concretions. It states that the high level module must not depend on the low level module, but they should depend on abstractions

The design encompasses entities as well as state transitions as a result of data in motion within the application and to/from external sources through a distributed systems approach. Those various aspects will be represented by the design diagrams outlined. Data flow diagrams reflect all of aspects of data at rest and in motion. They were used to show all these interaction by illustrating the external entities, process acting on the data, data store where the data is stored and data flow showing the movement. Use case diagrams were used to summarize the scenarios in which the prototype interacts with people, organizations and external systems. These diagrams are also pivotal in crystallizing the goals the actors need to achieve and most importantly draw the scope of the system and hence prevent scope creep in the face of time constraints. The underlying framework for this research is a pure internet of things approach and therefore multiple systems interact. System sequence diagrams expound more on each scenario of the use cases to bring out the events that external actors generate, their order and intersystem, events.

The information portrayed remain high level with the system being treated as black box. Activity diagrams were used to provide an overview of how flow control will be passed from one activity to another. This research is based on an area with massive data in motion and therefore it will be important to see how various activity work together as the data is passed along to ensure it integrity. The entity relationship diagram derived from the class diagram by showing the implementation details in the form of database tables and their relationship.

3.6.2 System Implementation

The learning of the model for predicting probability of failure was done using python. The model learned was implemented as a continuously running in the background and consuming messages off a queue. Every sensor value is passed through the model to determine how its values play out in the long run in terms of telling us about charging performance. Finally we used a python's matplotlib plotting library to visualize the trend of sensor values. This is a 2D plotting library which produces publication quality figures in a variety of hardcopy formats and interactive environments across platforms. These images act in input to the human experts who provide a second opinion given a system alert for failure.

3.6.3 System Testing

For testing we split the data using the 70% training data and 30% test data. The training data splitting approach was used with python and a 10 fold cross validation was performed. The confusion matrix is the basis of how well the model generalizes the data.

3.6.4 System Evaluation/Validation

Validation was performed to identify if the system is able to provide alerts in the event of deviation from known charge patterns. This was tested using regression methods which deliberately deviate the sensor values. After obtaining the necessary permissions, the prototype was run against selected production batteries working well. This enabled us to confirm that it reports those battery as healthy and with a low probability of future failure.

Chapter 4 : System Design and Architecture

4.1 Introduction

The blueprints for the proposed solution will be outlined in this sub section. As mentioned in section 3.6.1 the overall architecture follows an object oriented approach. Therefore analysis and design was done following the unified modelling language conventions to clearly outline the logical view of the system.

4.2 Requirements analysis

From the objectives for this research as well as business needs for failure prediction, there is a collection of both functional and non-functional requirements that need to be fulfilled.

4.2.1 Functional requirements

The model will be expected to fulfil the following functional requirements:-

- i. The application will accept data in JSON or CSV format.
- ii. The application should persist all battery charging data in relational store.
- iii. The application should be able to convert dates between different time zones.
- iv. The application should identify charging cycles from battery time series data.
- v. The application should compute charging gradients for every charging cycle.
- vi. The application should be able to clean out outliers in the charging data. E.g from the battery datasheet the maximum capacity never goes above 3300mAh.
- vii. The application should learn a linear regression model from the gradients from daily charging cycles.
- viii. The application should be able to illustrate via graphs the daily charging cycles.
- ix. The application should persist all learned models for fast prediction of future instances.

4.2.2 Nonfunctional requirements

The application has to fulfil a set of quality attributes while fulfilling the specific functional requirements. These quality attributes however need to be achieved in a cost efficient manner.

- i. Portability – The application needs to be developed in a way that it is cross platform such that it can run in all the major operating systems.
- ii. Accuracy and precision – This is a core of this model. It needs to achieve more than 80% of accuracy from the test data.
- iii. Reliability – As it deals with real-time streaming data. The mean time before failure (MTBF) will need to be kept at a minimum to achieve over 99.9% uptime.
- iv. Usability – Even though the users of this system will be fairly technical professionals, it needs to be easy to use to provide real value appropriation.
- v. Legal – The application needs to address all legal issues that may arise especially from the use of third party machine learning libraries.
- vi. Data integrity – The application needs to maintain the correctness of the data as it performs its preprocessing in preparation for machine learning tasks.

4.3 System architecture

Figure 4.1 illustrates the system architecture as will be adopted to aid device support operations officers to aid customers. It captures the flow of information from the point where battery charging data is obtained from the device communication store to the point where failure prediction is performed.

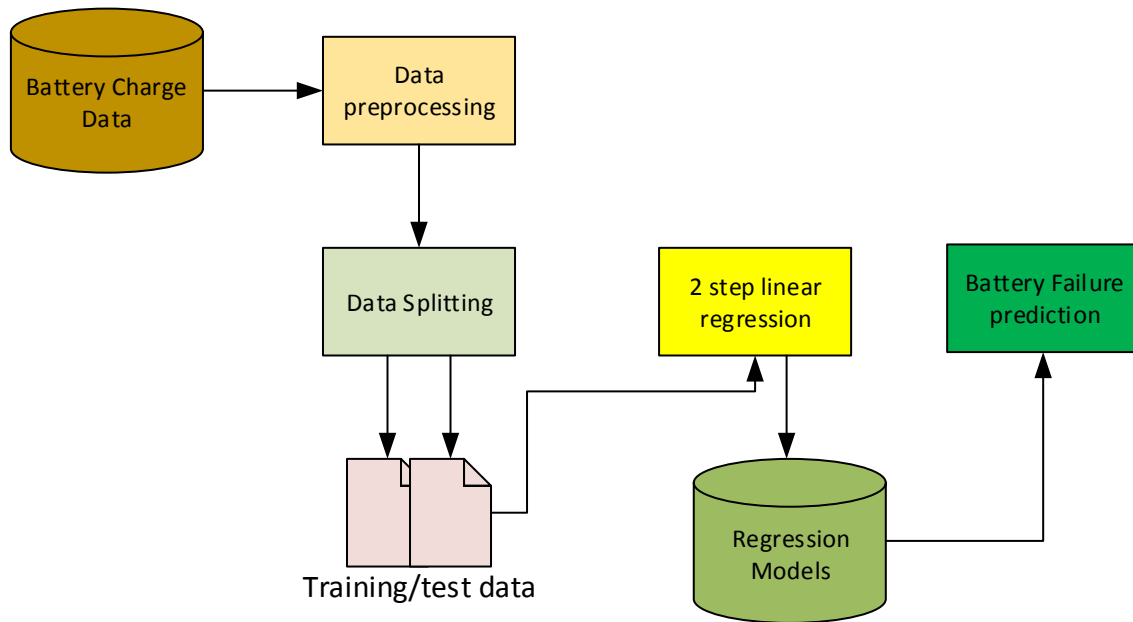

Figure 4.1: System Architecture

Data pre-processing will involve conversion of the data to values more palatable to the machine learner and researcher as well. These will included conversion of the battery charge from MAh to

Ah. It will also involve conversion of times from UTC to East African Time. The data will consist of values from good batteries and also failed batteries. A 2-step linear regression step will be performed on a predefined period, potentially after every 24 hours when all the days charging data and been received from the devices. The Regression models generated will be saved either in an appropriate file system, either a relational database or a file system. These models will act as the input for the battery failure prediction module as deviation from known patterns will be detected early on.

4.4 Model Design

4.4.1 Use Case Diagram

The system's interaction with external components and users is illustrated in figure 4.2. The major actors here are the device operations support user and the device communications system. The boundaries are the confines of scope within which the system has to perform battery failure prediction within acceptable constraints of accuracy.

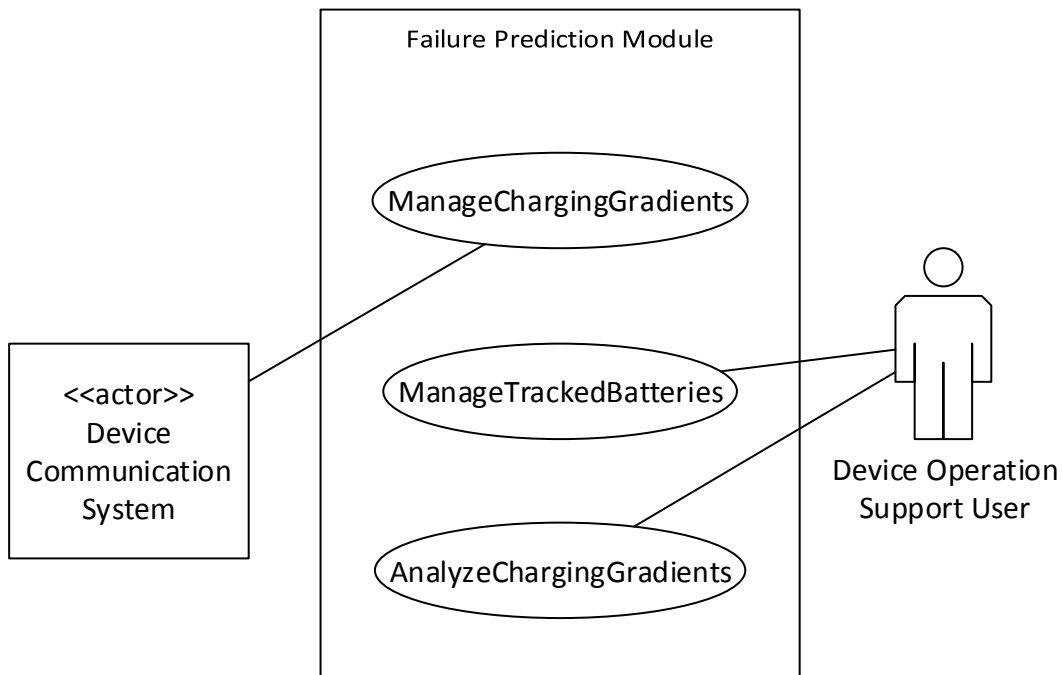

Figure 4.2: Failure Prediction use case diagram

The system therefore features three main use cases. These use cases will be described using the brief style format in a terse one paragraph of only the main scenario.

Use case description

Use Case: Manage Charging gradients

At the predefined time of day, preferably at midnight East African time, the failure prediction module will send a request for day's battery charging data from the device communication system. On receiving the data, the system will preprocess it by converting values into a format it can feed the machine learner. For each of the battery data received for the day, the system will calculate the charging gradient and persist in a store. It will then use these to compare with existing known good charging patterns to identify batteries with potential of failure.

Use Case: Manage Tracked Batteries

As new devices are continuously added to the system and others removed, the device support operations user will request a list of all existing devices. From that the use will determine which devices to add to the list of tracked devices and which to remove based on business requirements.

Use Case: Analyze Charging Gradients

A Device support operations user needs to give a report of which devices have batteries that have potential of failure in order to perform proactive swaps. The use therefore requests the list of flagged devices from the system and performs further analysis by observing the trends of the gradients against known values. This forms the decision to mark the device as actually failing that is, having the potential to fail in the future.

4.4.2 Entity Relationship Diagram

The system features 3 main entities which have been illustrated using crow foot's notation of database modelling in Figure 4.3.

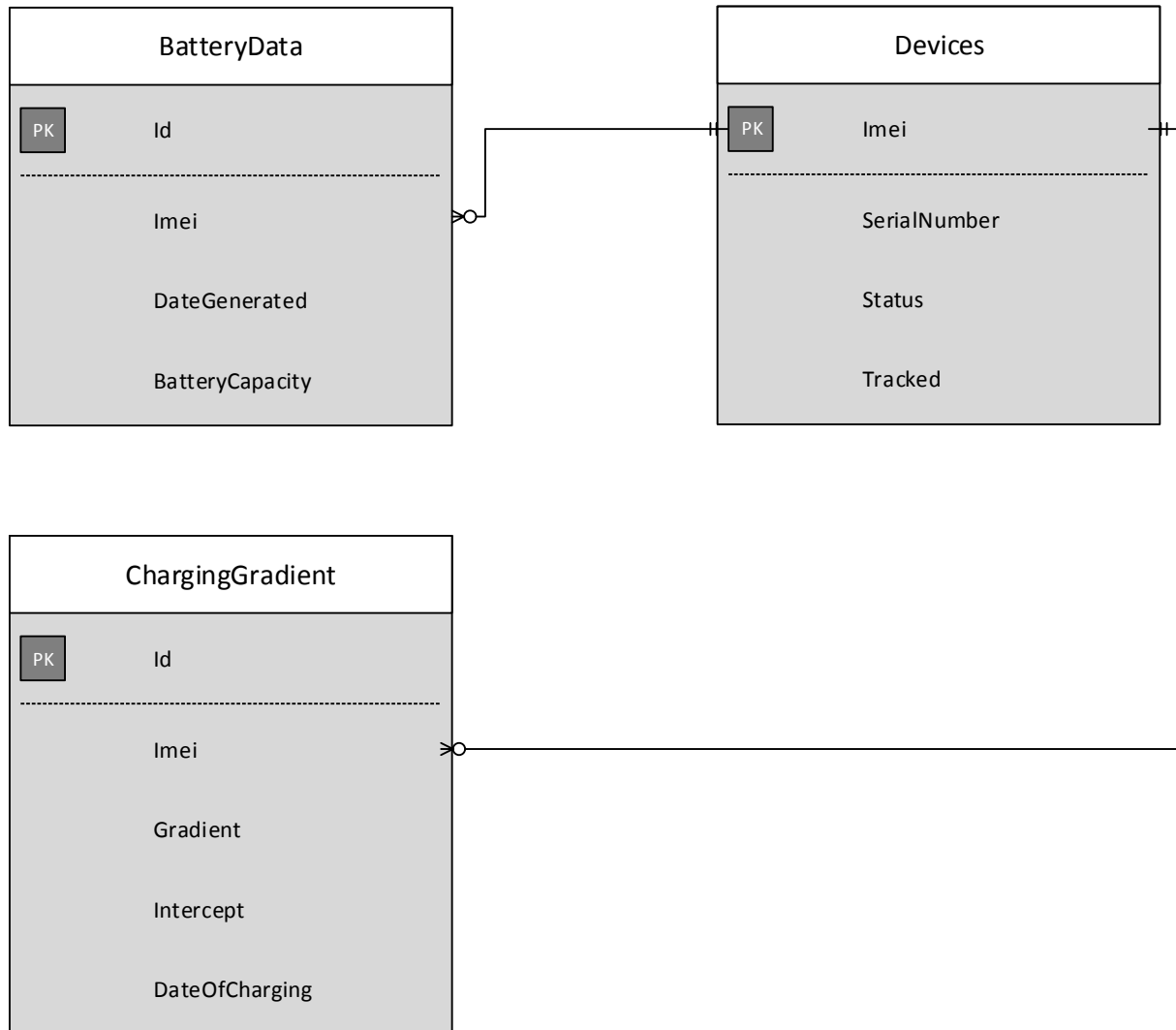

Figure 4.3: Failure Prediction System Entity Relationship Diagram

The description of these entities is as follows:-

- i. **Devices** – From an inventory management perspective, the devices give us access to the batteries as they are attached together. Therefore the lmei of the devices is the identifier of the battery. The status property represents whether a device has been marked as failing. The tracked property is Boolean for either being tracked or not.

- ii. Battery Data – This table simply holds the data that is send from the device periodically. The data is much more but of pertinence to this research are the fields given.
- iii. Charging Gradients – Whenever the charging gradients are calculated, then these gradients will be stored in this table to enable a time series comparison of the changes in the gradients.

4.4.3 Activity Diagram

In order to show the dynamic nature of the prediction system, we will complement the diagrams previous given with the activity diagram in Figure 4.4. The flow of activities reflected correspond to the architecture presented in section 4.1. The activities that the systems performs to provide an accurate prediction are as follows:-

- i. Data request – This data is pulled from the device communication store. The specific time series data points for battery capacity are provided.
- ii. Preprocessing – That date and time are in UTC and need to be converted to a more friendly timing. The capacity is converted to Ah from MAh. The date is pushed forward by 3 hours from UTC to East African Time.
- iii. A linear regression of each of the batteries charging data is performed. It is this gradient that acts as an indicator of how well the battery is charging and hence and indicator of if it might fail or not.
- iv. The gradients for the battery daily charging is persisted for further processing.
- v. Further processing involves looking at all captured gradients and determining their variation from a known good charging rate.
- vi. The outcome of this decision means that specific devices will be flagged as needing battery replacement.

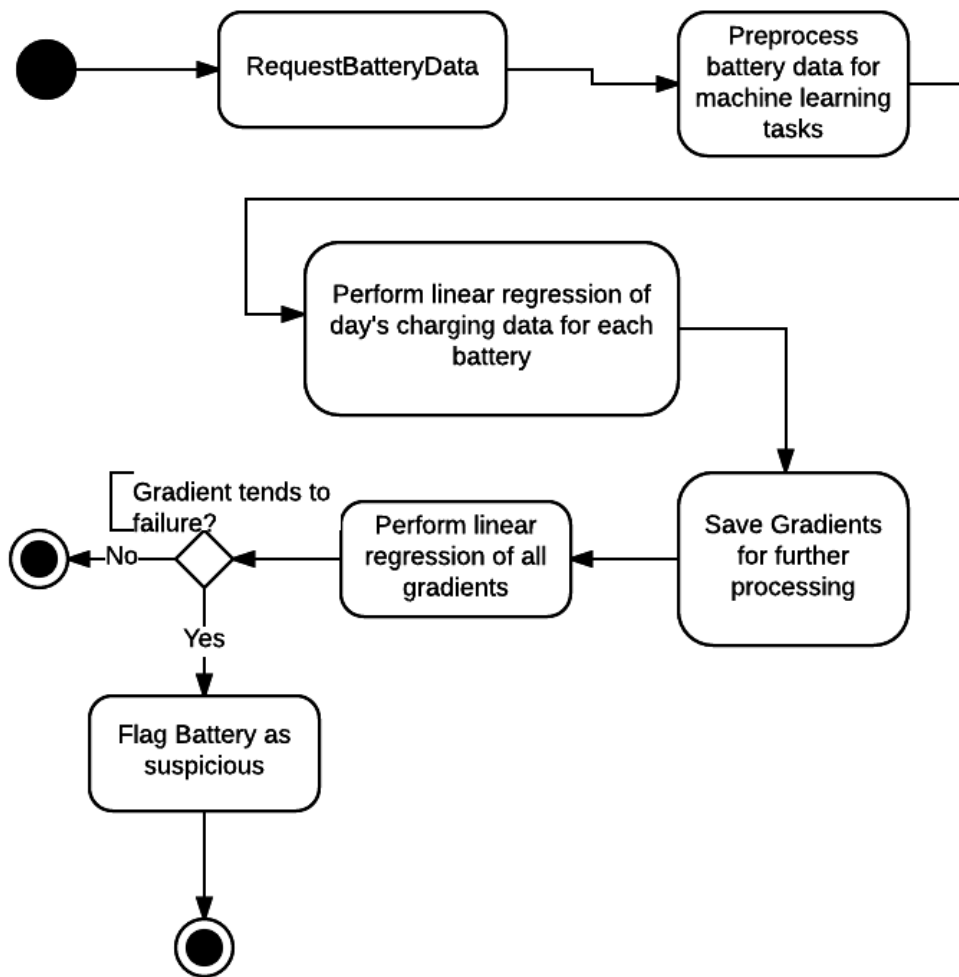

Figure 4.4: Prediction Activity Diagram

4.4.4 System Sequence Diagram

The flow of the messages between various components is provided by system sequence diagrams in Figures 4.5, 4.6 and 4.7. These diagrams are a representations of the use cases given in section 4.4.1. Figure 4.5 represents the message between the device communication systems and the failure prediction module to retrieve daily charging data for the batteries.

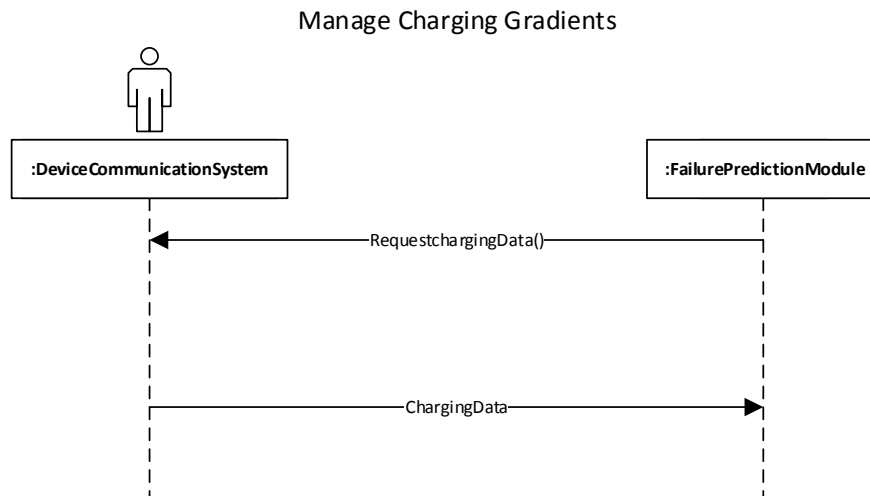

Figure 4.5: Manage Charging gradients System Sequence Diagram

Figure 4.6 represents the messages between the actor users who mark the specific devices that need to be tracked. This is particularly important so as to ensure that only the necessary devices are tracked. The case for this is the fact that devices in the warehouse will still communicate and we would want to avoid a scenario where there is overhead in the system due to such devices.

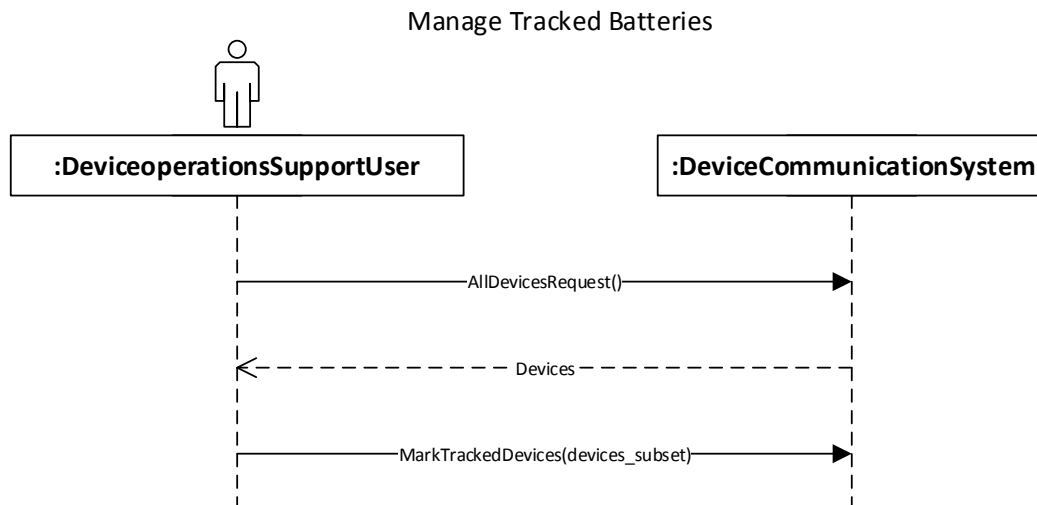

Figure 4.6: Manage Tracked Batteries System Sequence Diagram

Figure 4.7 illustrates the interaction that happens when an actor user needs to perform further triage on batteries and requests the failure prediction model.

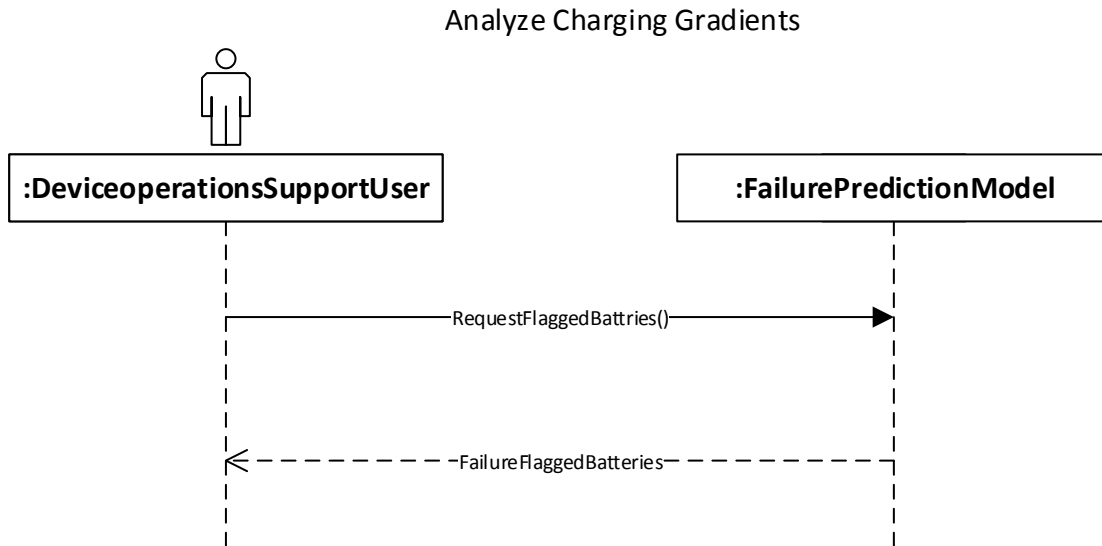

Figure 4.7: Analyze Charging Gradients System Sequence Diagram

4.4.5 Context Diagram

The context diagram in figure 4.8 represents the flow of data between the system and 2 primary entities. The device communication system will provide the battery charging data while the support user will manage tracked batteries as well as view a report of fail predicted batteries.

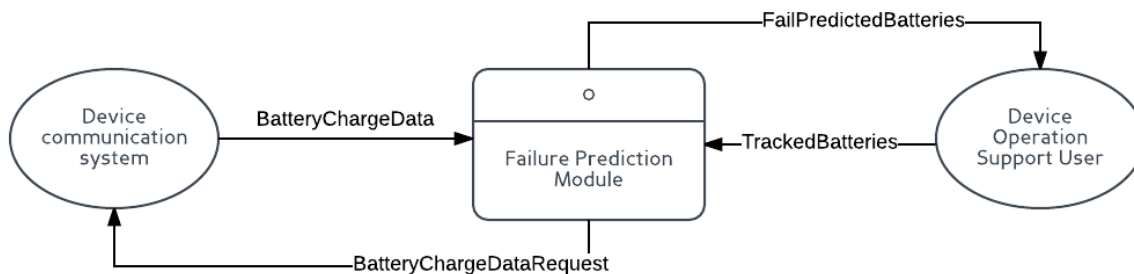

Figure 4.8: Failure Prediction Model DFD Context Diagram

4.4.6 Level 0 DFD

The level 0 context diagram in figure 4.9 expounds more on the context diagram in figure 4.8. This is through the illustration of the fragments now introducing data stores. These data stores are consistent with the various tables highlighted in the Entity relationship diagram in figure 4.3.

Chapter 5 : Implementation and testing

5.1 Introduction

The model was implemented through a series of activities from data capture to validation by use of the test data. It began with the collection of 2 sets of data which was similar in format. The first set was the battery charging data from “good devices”. The assumption was made here that a device was in a good working condition if it was still allocated to a customer. The second set of data was obtained from the Engineering team for devices which were known to have failed and diagnosis led to a clear indication that the devices had failed due to failure in battery by draining too fast. Subsequent sections will expound more on the specific tasks that were performed on this data to generate a model deemed sufficient for predictive analytics for battery failure.

5.2 Implementation tools

The model was implemented as an extension to an existing device communication system which doubles up as an inventory management system. The choice of the language of implementation; python, is based on its strong support for machine learning and especially the strong community support. The specific tools used here were as follows:-

- i. Operating environment – All development was done on a Windows 10 environment on a machine with a core I3 processor at 2.1GHZ and 6GB RAM.
- ii. Python – All machine learning related tasks were performed using python version 2.7.
- iii. Libraries – The machine learning libraries used were Tensor Flow and scikit-learn. Scikit learn was particularly useful in dealing with extremes in the input data while TensorFlow has the power of providing the raw tools to visualize learning as it happened through the tensor flow graph. Through this, it was possible to obtain the error rate from every epoch and hence plot the cost curve.
- iv. Package management – It was a challenge using the pip package manager for windows as some of the libraries were not supported at the time of doing the research. Therefore, the standalone version of Anaconda called miniconda was used. In addition, windows does not have support for TensorFlow at the time of this research and hence necessitated the use of bash on windows by installing the Linux distribution for windows.

- v. Charting – matplotlib is a python library for producing interactive graphs. It was widely used to help with visualizing the changes in charge gradient and provide a user friendly information for inference.
- vi. Development environment – All scripts were written using the basic editor; Notepad++.
- vii. Data stores – All the data was stored in a SQL server database. Some of the models where however persisted in the file system.

5.3 Model Components

5.3.1 Data preprocessing Components

The Initial step prior to performing any form of learning on the data is conversion of values as mentioned in earlier sections. These are the conversion of capacity from mAh to Ah and time to East African time by adding 3 hours. This preprocessing was performed in memory as the working computer memory was sufficiently large to hold the training and test dataset.

5.3.2 Step 1 linear regression

The very first step from the preprocessed training data set was calculation of gradients from each of the batteries from the time series data. No further processing was performed on the gradients; they were persisted to a data store as is. This was performed for both the good batteries and those which had failed. Figure 5.1 shows a time series capacity graph of a battery three day charging cycle for a good battery. From the quick inspection, it is clear that assuming constant charging voltage, the rate of charging remains fairly constant.

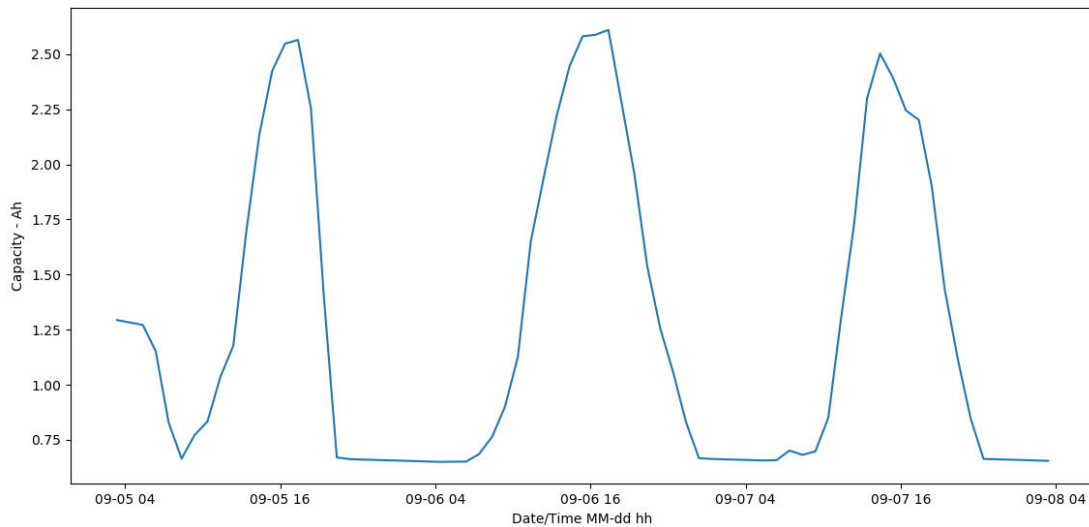

Figure 5.1: Battery Charging Cycle

5.3.3 Step 2 Linear regression

With all the individual battery charging gradients saved in a database table and clearly marked which gradients represent the good and failed batteries, the next step was to find a fit for the gradients. The general bias was that it was expected that the curve would have a small upward trend with a small error rate from a horizontal line. This would be caused by the fact that the charging rates of good batteries more or less remain fairly stable but due to natural degradation cycle by cycle, then the line would not be perfectly horizontal. The outcome of this step led to the complete training data as these first 2 steps were considered preprocessing steps.

5.4 Model Implementation

The model implementation involved using the training data produced from step 2 linear regressions. The features of the data were the slope of the charging trends, the intercept as well as a flag for showing where a battery had been faulty. The flag for faultiness represented the label. A supervised learning approach using k-nearest neighbor was used with 10 neighbors. The model was serialized and persisted into text file using python's pickle library.

During the initial regression, there was a challenge of finding the best line of fit considering all the data provided. In order to fix this, charging data was assumed to only be between 6a.m. to 6.p.m. at any given day. This was important because customers had different

behaviors of charging their phones. The other assumption was that within each given day, there is only one charging cycle.

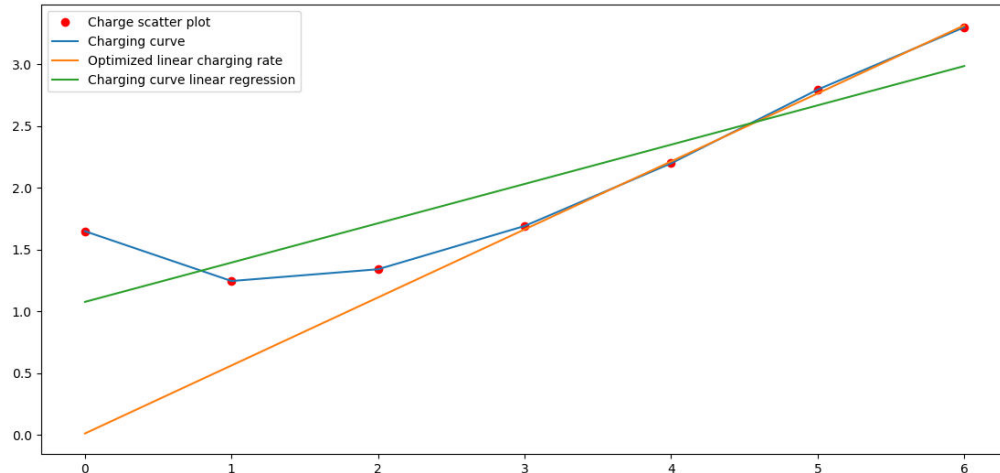

Figure 5.2: Optimizing the charging curve

Figure 5.1 shows how overfitting the data would lead to an incorrect gradient on the charging curve (see green line). The more correct line is the orange line. The plot was created by selecting only 3 data points which had the largest differentials between them. All the optimized gradients were regressed to find the general charging pattern for good devices. From the failed devices, it was determined the average error rate from the known devices.

5.5 Model Training

The training set comprised of 70% of the data set. This was pulled from both the good and faulty batteries. As discussed in sections 5.3.3 and 5.3.4 a two-step linear regression process was performed. Training was done to fit a curve to the data points by learning the slopes and intercepts. Training was repeated until the error rate could not be reduced further for 100 subsequent epochs. This approach was preferred as it allowed a relative error value.

5.6 Model testing

The test set comprised of 30% of the data set. Again this was data from both good and failed battery data. This data was used to verify the model learned as explained in section 5.5. The outcome of this process was the confusion matrix on how well the trained model generalized the data.

5.7 Acceptance testing

Acceptance testing involved ensuring that the requirements as outlined in section 4.2 were met. Table 5.1 presents the test cases around the functional requirements and comments accompanying the test outcomes. The test cases are derived from the requirements.

Table 5.1: Acceptance test cases and results

Test Case	Test Outcome	Comment
The application should persist all battery charging data in relational store.	PASS	This was done in a relational store; SQL server
The application should be able to convert dates between different time zones.	PASS	Primarily converted original data from UTC to EAT by adding 3 hours.
The application should identify charging cycles from battery time series data.	PASS	Performed the cycle computing during data preprocessing.
The application should compute charging gradients for every charging cycle.	PASS	OK
The application should be able to clean out outliers in the charging data. E.g from the battery datasheet the maximum capacity never goes above 3300mAh.	PASS	OK
The application should learn a linear regression model from the gradients from daily charging cycles.	PASS	OK

Test Case	Test Outcome	Comment
The application should be able to illustrate via graphs the daily charging cycles.	PASS	OK.
The application should persist all learned models for fast prediction of future instances.	PASS	OK

Chapter 6 : Discussions

6.1 Introduction

The failure prediction model was implemented using the battery capacity feature from the battery data. This data was captured during an hourly basis when the batteries are operational and transmitted to a backend server. The model creation therefore relied heavily on time series data for prediction of batteries with the probability of failure. This model came out on top compared to other conventional methods that were in use by the battery support technicians. The model was able to provide a high level of prediction accuracy as opposed to the technicians who could only tell when the device had already failed. At the same time the business largely depended of customers who used this batteries to call complaining that the batteries were no retaining charge. Clearly this is not a good customer experience and would be bad for business especially for a revenue model that relies on repeat buys. This proactive replacement of batteries was selected as a cost effective method as the other option that was viable was to change the batter supplier and overhaul the device assembly but the cost associated with the logistics of this change meant that simply performing a battery change on the batteries that had an issue would be a cost effective option. In addition, it was the best approach which necessitated this research as switching battery suppliers was not a guarantee that there would be a complete stop to faulty batteries.

The model developed from this research provides a prediction based on error rate reduction with exemplary accuracy. This was done by applying a 2 step linear regression algorithm on time series data from battery capacity data. The accuracy of the algorithm ensured not just efficiency in the failure prediction but also guaranteed process efficiencies in how the technicians were able to respond to queries to verify faulty batteries. The process efficiencies saw sharp decrease in the turnaround time to servicing customer requests as well as allowed performing of predictive swaps.

6.2 Model Validation

The model was validated for both accuracy and precision by performing cross validation against the test data. Out of the 60 instances(in this case batteries), 48 were correctly marked as either being good or faulty based on one month time series data. These characteristics where

flagged by the algorithm as early as in a duration of 2 weeks. This represented an accuracy of approximately 80%.

Table 6.1: Model Validation

	Value	Percentage
Correctly classified instances	48	80%
Incorrectly classified instances	12	20%
Total Test instances	60	100%

The accuracy of 80% still presents a value below desirable rates. There is a need to improve the accuracy of the algorithm and some of the suggestions of how to do that will be presented in section 6.6.

6.3 Error minimization

The accuracy of the model in this research was largely dependent on minimization of the error rate on multiple layers of machine learning. Therefore it was important to ensure that this error was optimized to the smallest value possible. The error minimization process dependent highly on removal of outliers. There were one off cases where the gradients did not match indicating that the device was charging too fast or too slow compared to immediate neighbors in adjacent charging cycles. These cases had to be removed in order to avoid overfitting the data.

6.4 Confusion matrix

The confusion matrix in Table 6.2 is used to describe the state of classification of the test instances. It is used to demonstrate the accuracy of the model on actual vs classified instances.

Table 6.2: confusion Matrix

N=60	Predicted: Faulty	Predicted: Good	
Actual: Faulty	TN=28	FP=7	35
Actual: Good	FN=5	TP=20	25
	33	27	

TN=True negative, FP=False positive, FN=False negative, TP=True positive

The green diagonal represents the correctly classified instances which amount to a total of 48 instances. These are the 80% which are classified correctly. The other 12 instances are the 20 percent incorrectly classified.

6.5 Model contributions to research

The time of this research was timely as the model produced helped in making proactive decisions. The device operations support users were tasked with performing troubleshooting on devices at a time when the customers who had bought the batteries were experiencing less than desirable performance. So this meant that the specific responsibilities changed from having to respond to queries to reporting potentially failing batteries before they actually do. This is a massive process optimization which can also be applied to many other areas and utilized as a source of competitive advantage.

6.6 Shortcomings of the research

The model from this research was developed with the following limitations:-

- i. It did not consider other battery parameters such as voltage, charging current.
- ii. If a battery had more than one charging cycle within 24 hours, only the first is selected and subsequent cycles would be ignored.
- iii. The research takes into account only the battery failure due to fast charging and discharging.

Chapter 7 : Conclusion and Recommendations

7.1 Conclusion

The objectives of this research were to look at the current operations of Lithium-Ion batteries especially the specific failure types. The research narrowed down to solar charged lithium-Ion batteries which are in use by the company this research was scoped to. The main deliverable of the research was using data from the batteries to learn a model that would be used to predict failure on the batteries. The specific failure type focused on was rapid charging and discharging. Through a combination of interviews and observation, it was found that the device operations support users were spending a lot of time performing troubleshooting to determine which devices had issues. The nature of that task was simply to perform a verification of a claim of failure. The research trained a model and a proof of concept to predict the failure from battery data with only one month worth of time series data. The model was validated against test data using a data split and was also validate to fulfil functional requirements. Due to the financial limitations surrounding this research it was not possible to validate most of the nonfunctional requirements.

Therefore, based on the outcome from the research as well as prior review of related material on the subject, it can be said that all the research objectives were met while at the same time answering all research questions. As such this research is regarded as having been concluded successfully.

7.2 Recommendation

Based on the outcomes of this research, the most important recommendation is the full implementation of the design as detailed in chapter 4. With the tested model, there will be a complete learning framework that has massive gains to the service levels as outlined in the company's service charter. As seen from the design this research is a complete plug and play system where automated reports would be generated flagging all batteries which could potentially fail.

7.3 Suggestions for future research

Below are suggestions for future research which can use this research as a stepping block for further development:-

- i. Incorporation of charging current and voltage as part of the learning feature when determining the charging rate of the batteries.
- ii. Selection of data from a longer time period as a means to improve the accuracy of the model.
- iii. Research that determines other forms of battery failure and flags not only failure due rapid charge but also other aspects such as early onsets of thermal runaway.

References

- Azasoo, J., & Boateng, K. (2015). A Retrofit Design Science Methodology for Smart Metering Design in Developing Countries. *2015 15th International Conference on Computational Science and Its Applications*, (pp. 1-7). Banff.
- Abraham, A., & Hassan, A. K. (2013). Modeling consumer loan default prediction using ensemble neural networks. *Computing, Electrical and Electronics Engineering (ICCEEE), 2013 International Conference* (pp. 719-724). Khartoum: 2013.
- Anwar, S., Izadian, A., & Sidhu, A. (2015). Adaptive Nonlinear Model-Based Fault Diagnosis of Li-Ion Batteries. *IEEE Transactions on Industrial Electronics*, 1002-1011.
- Apley, D. W., & Shi, J. (1994). A fault detection, isolation, and identification technique for complex MISO linear systems. *American Control Conference* (pp. 2633 - 2637). Baltimore, Maryland: University of Michigan.
- Barrow, D., Crone, S., & Kourentzes, N. (2010). An evaluation of neural network ensembles and model selection for time series prediction. *The 2010 international joint conference on neural networks (IJCNN)* (pp. 1-8). Barcelona: Lancaster University Management School.
- Belov, D., & Yang, M.-H. (2008). Failure mechanism of Li-ion battery at overcharge conditions. *Journal of Solid State Electrochemistry*, 885-894.
- Brodd, R. J. (2013). Comments on the History of Lithium-Ion Batteries. *The Electrochemical Society*, 1.
- Choi, J., & Patil, A. (2006). Review of issue and challenges facing rechargeable nanostructured lithium batteries. *Nanotechnology Materials and Devices Conference* (pp. 196-197). IEEE.
- Chunhua, H., Ren, H., Runcai, W., & Jianbo, Y. (2012). Fault prediction and fault-tolerant of lithium-ion batteries temperature failure for electric vehicle. *Digital Manufacturing and Automation (ICDMA), 2012 Third International Conference* (pp. 410-413). IEEE.

- Corbin, K. (2016). *Government security workers have a big data problem*. Retrieved from <http://www.cio.com/>: <http://www.cio.com/article/2915900/big-data/government-security-workers-have-a-big-data-problem.html>
- Delgado-Ballester, E., & Luis, M.-A. (2001). Brand trust in the context of consumer loyalty. *European Journal of marketing*, 1238-1258.
- Doughty, D., & Roth, P. (2012). A general discussion of Li ion battery safety. *Electrochemical Society Interface*, 37-44.
- Fang, H., Fan, H., Ma, H., Shi, H., & Dong, Y. (2015). Lithium-ion batteries life prediction method based on degenerative characters and improved particle filter. *Prognostics and Health Management (PHM), 2015 IEEE Conference* (pp. 1-10). IEEE.
- Gorka, T., Hu, C., Jain, G., & Tamirisa, P. (2014). Method for estimating capacity and predicting remaining useful life of lithium-ion battery. *Applied Energy*, 182-189.
- Hamilton, R., & Pocock, R. (2006). Batteries: Always Expected to Perform but Why Don't They? In *2006 Record of Conference Papers-IEEE Industry Applications Society 53rd Annual Petroleum and Chemical Industry Conference* (pp. 1-5). IEEE.
- Hamsic, N., Mohd, A., Ortjohann, E., & Schmelter, A. (2008). Challenges in Integrating Distributed Energy Storage. *IEEE international symposium on industrial electronics* (pp. 1627-1632). IEEE.
- Han, X., Lu, L., Hua, J., & Ouyang, M. (2013). A review on the key issues for lithium-ion battery management in electric vehicles. *Journal of power sources*, 272-288.
- Haodong, M., Hongzheng, F., Huanzhen, F., & Hui, S. (2015). Lithium-ion Batteries Life Prediction Method based on Degenerative Characters and Improved Particle. *Prognostics and Health Management (PHM)* (pp. 1-10). Austin, TX: Beijing Aerospace Measure & Control Corp (AMC). Ltd.
- International Finance corporation. (2016, 10 7). *Scaling solar*. Retrieved from <http://www.ifc.org>
- Ji, Y., Wang, C., & Zhang, Y. (2013). Li-ion cell operation at low temperatures. *Journal of The Electrochemical Society*, 636-649.

- Kwan, C., Zhang, X., Xu, R., & Haynes, L. (2003). A novel approach to fault diagnostics and prognostics. *IEEE International Conference* (pp. 604 - 609). Taipei, Taiwan: IEEE .
- Leng, F., Tan, C., & Pecht, M. (2015). Effect of Temperature on the Aging rate of Li Ion Battery Operating above Room Temperature. *Scientific reports*, 1-12.
- Liu, D., Xie, W., & Peng, Y. (2015). An integrated probabilistic approach to lithium-ion battery remaining useful life estimation. *IEEE Transactions on Instrumentation and Measurement* (pp. 660-670). IEEE.
- Long, R., Kahn, M., Mikolajczak, C., & White, K. (2012). *Lithium-ion batteries hazard and use assessment*. Springer Science & Business Media.
- Luo, H., Han, X., Yu, Y., & Wang, S. (2016). An empirical study on the effect of consumer complaints handling on consumer loyalty. *Service Systems and Service Management (ICSSSM)* (pp. 1-6). IEEE.
- Ma, H.-M., Meng, C.-C., Zhu, K., & Jun-Y. (2008). An empirical research of consumer loyalty model in B2C electronic commerce. *Wireless Communications, Networking and Mobile Computing, 2008. WiCOM'08. 4th International Conference* (pp. 1-6). IEEE.
- Omar, M., Trigunaryah, B., & Wong, J. (2009). A Design Science Approach for Consultant Selection Decision Support System. *2009 Fourth International Conference on Cooperation and Promotion of Information Resources in Science and Technology*, (pp. 90-94). Beijing.
- Polycarpou, M. M. (1994). An on-line approximation approach to fault diagnosis and accommodation. *American Control Conference* (pp. 1722-1726). Baltimore, Maryland: University of Cincinnati.
- Recharge. (2013). *Safety of lithium-ion batteries* . Belgium: Recharge.
- Spence, E. (2016, 11 19). *Samsung Galaxy Note 7 Has Left The United States*. Retrieved from Forbes: <http://www.forbes.com/sites/ewanspence/2016/11/07/samsung-galaxy-note-7-recall-success/>

- Tarascon, J. M. (2010). Key challenges in future Li-battery research. *Philosophical Transactions of the Royal Society of London: Mathematical, Physical and Engineering Sciences*, 3227-3241.
- Vinel, A., Wang, L., Xia, F., & Yang, L. (2012). Internet of things. *International Journal of Communication Systems*, 1101.
- Wang, X. (2012). A new model for measuring the accuracies of majority voting ensembles. *The 2012 International Joint Conference on Neural Networks* (pp. 1-7). Nampa: Northwest Nazarene University .
- Witten, I., & Frank, E. (2005). *Data Mining: Practical machine learning tools and techniques*. Morgan Kaufmann.
- Xing, Y., Ma, E., Tsui, K., & Petch, M. (2012). A case study on battery life prediction using particle filtering. *Prognostics and System Health Management (PHM)* (pp. 1-6). IEEE.

APPENDIX A: Basics of Lithium-Ion Battery

Most consumer battery packs available assume various form factors but with a standard approach of a negative electrode made from carbon/graphite coated onto a copper current collector, a metal oxide positive electrode coated onto an aluminum current collector, a polymeric separator, and an electrolyte composed of a lithium salt in an organic solvent (Long, Kahn, Mikolajczak, & White, 2012). A battery pack usually consists of multiple cells connected wither in series or in parallel. When the cells are connected in parallel this increases the pack's capacity and when in series voltage. For example a pack marked as 12 volts, 13.2Ah, could potentially mean that it contains 3 cells each with a voltage of 4 volts and capacity of 13.2 Ah. If connected in series then we expect to have 4 volts and (13.2×3) 39.6 Ah i.e increased capacity. These configurations will form an important basis as we examine the ever so growing popularity of the LiB family for commercial and domestic use.

APPENDIX B: Turnit in originality report

Matthew Mutiso | Failure prediction model for solar charged lithium-Ion batteries ?

ged lithium-Ion batteries

D

Degree of Master of Science in Information
University

Match Overview ×

18%

1	Submitted to Strathmor... <small>Student Paper</small>	1%	>
2	Fang, Hongzheng, Huan... <small>Publication</small>	1%	>
3	Xing, Yinjiao, Eden W. M... <small>Publication</small>	1%	>
4	Liu, Datong, Wei Xie, Ha... <small>Publication</small>	1%	>
5	wiki.dpi.inpe.br <small>Internet Source</small>	1%	>
6	D.W. Apley, Jainjun Shi. ... <small>Publication</small>	1%	>
7	www.electrochem.org <small>Internet Source</small>	1%	>