

From INSTITUTE OF ENVIRONMENTAL MEDICINE

Karolinska Institutet, Stockholm, Sweden

EXPERIMENTAL STUDIES ON ACUTE HEALTH EFFECTS OF ACROLEIN AND OTHER ALDEHYDES

Aishwarya Mishra Dwivedi



**Karolinska
Institutet**

Stockholm 2017

All previously published papers were reproduced with permission from the publisher.

Published by Karolinska Institutet.

Printed by Eprint AB 2017

© Aishwarya Mishra Dwivedi, 2017

ISBN 978-91-7676-873-0

Experimental studies on acute health effects of acrolein and other aldehydes

THESIS FOR DOCTORAL DEGREE (Ph.D.)

By

Aishwarya Mishra Dwivedi

Principal Supervisor:

Associate professor Lena Ernstgård
Karolinska Institutet
Institute of Environmental Medicine
Work Environmental Toxicology

Co-supervisor(s):

Professor Gunnar Johanson
Karolinska Institutet
Institute of Environmental Medicine
Work Environmental Toxicology

Associate Professor Lena Palmberg
Karolinska Institutet
Institute of Environmental Toxicology
Work Environmental Toxicology

Associate Professor Johnny C. Lorentzen
Karolinska Institutet
Institute of Environmental Toxicology
Center for Occupational and Environmental Medicine

Opponent:

Professor George D Leikauf
University of Pittsburgh
Public Health
Environmental and Occupational Health

Examination Board:

Docent, Adj Professor Anna-Carin Olin
Gothenburg University
Institute of Medicine
Department of Public health and Community

Professor Anna Rask-Andersen
Uppsala University
Department of Medical Sciences
Occupational and Environmental Medicine

Professor Per Gustavsson
Karolinska Institutet
Institute of Environmental Medicine
Occupational Medicine



This thesis is dedicated to the memory of my loving Nana Ji & Papa Ji

ABSTRACT

Aldehydes are reactive and ubiquitous in indoor as well as outdoors and can give rise to significant health problems in humans, e.g. irritation of the eyes and toxic effects on the upper respiratory tract. This thesis focuses on the irritating and inflammatory properties of three commonly occurring aldehydes; acrolein, crotonaldehyde and hexanal.

Male and female volunteers were exposed in a controlled environment at six occasions for 2 hours to clean air only, 15 ppm ethyl acetate (EA) only and 0.05 ppm and 0.1 ppm acrolein with and without EA (Paper I). No significant exposure-related adverse effects (pulmonary function, nasal swelling, and inflammatory markers, coagulation markers, cell differentials, breathing frequency, symptom ratings except eye irritation) were found. The ratings of eye irritation were slightly but significantly increased during exposure to 0.1 ppm acrolein alone as well as combined with EA. Blinking frequency was only increased at 0.1 ppm acrolein alone.

Employing a novel olfactometer developed in-house, we determined odor (OT) and lateralization (LT) thresholds in naïve subjects (Paper II). The median OTs was similar to or lower than previously reported: 17 ppb (acrolein), 0.8 ppb (crotonaldehyde) and 97 ppb (hexanal).

We compared pulmonary pro-inflammatory and oxidative stress responses in seven inbred strains of mice after 11 weeks of whole body exposure to 1 ppm acrolein with filtered air as the control (Paper III). The responses varied widely between strains, and were in general agreement with that expected from previously reported survival times in the same mouse strains after acute exposure to 10 ppm acrolein.

The inflammatory and toxic effects of acrolein (0-0.5 ppm), crotonaldehyde (0-5 ppm) and hexanal (0-50 ppm) were further studied in a newly developed exposure system allowing for airborne exposure of differentiated human pulmonary bronchial epithelial cells (PBEC) co-cultured with fibroblasts at an air- liquid interface (Paper IV). The release of inflammatory markers and the corresponding mRNA expressions increased. These effects were not observed with exposure of PBECs under submerged conditions.

The findings herein provide new insights in the acute effects of environmentally realistic exposure-concentrations of acrolein, crotonaldehyde and hexanal. The results may prove helpful in future risk assessment and risk management efforts, such as setting health-based occupational exposure limits.

LIST OF SCIENTIFIC PAPERS

- I. **Aishwarya M. Dwivedi**, Gunnar Johanson, Johnny C. Lorentzen, Lena Palmberg, Bengt Sjögren and Lena Ernstgård; Acute effects of acrolein in human volunteers during controlled exposure. *Inhalation Toxicology*, 2015; 27 (14); 810-821.
- II. Lena Ernstgård, **Aishwarya M. Dwivedi**, Johan N. Lundström and Gunnar Johanson; Measures of odor and lateralization threshold of acrolein, crotonaldehyde and hexanal using a novel vapor delivery technique. *PLoS One*, 2017 26; 12 (9): e0185479.
- III. Swapna Upadhyay, **Aishwarya M. Dwivedi**, Lena Ernstgård, Lena Palmberg, Lung Chi Chen, Karen Galdanes, Terry Gordon and Gunnar Johanson; Variation of inflammatory and oxidative stress responses among inbred mouse strain following sub-chronic inhalation exposure to acrolein. Manuscript.
- IV. **Aishwarya M. Dwivedi**, Swapna Upadhyay, Gunnar Johanson, Lena Ernstgård and Lena Palmberg; Inflammatory effects of acrolein, crotonaldehyde and hexanal vapors on human bronchial epithelial cells cultured at air-liquid interface. *Toxicology in Vitro*, 2017; (46) 219-228.

TABLE OF CONTENTS

List of abbreviations	9
1 Introduction	10
1.1 Aldehydes	10
1.1.1 Acrolein	12
1.1.2 Crotonaldehyde	14
1.1.3 Hexanal	16
1.2 Test systems	18
1.2.1 Human exposure by inhalation	18
1.2.2 Thresholds for odor and lateralization	18
1.2.3 Mice exposure by inhalation	19
1.2.4 <i>In-vitro</i> test system	20
2 Aims	22
3 Materials and Methods	23
3.1 Human volunteers	23
3.2 Exposure of humans via inhalation (Paper I)	23
3.2.1 The exposure chamber	23
3.2.2 Rating of symptoms	24
3.2.3 The frequencies of blinking and breathing	25
3.2.4 Pulmonary function	26
3.2.5 Nasal swelling	26
3.2.6 Markers of inflammation and coagulation in blood and induced sputum	27
3.3 Thresholds for odor and lateralization (Paper II)	27
3.3.1 The olfactometer	27
3.3.2 Confirmation of the odor threshold using amber bottles	28
3.4 Exposure of mice to acrolein (Paper III)	28
3.4.1 Mice exposure	28
3.4.2 Bronchoalveolar lavage	29
3.4.3 Preparation of lung homogenate	30
3.5 RNA/cDNA synthesis	30
3.6 Markers analyzed with the real-time polymerase chain reaction	31
3.7 Exposure of the airway mucosa model (Paper IV)	31
3.7.1 Primary bronchial epithelial cells	31
3.7.2 Culturing human lung fibroblasts	31
3.7.3 The chamber for exposure of cells	33
3.7.4 Exposure at air-liquid interface	33
3.7.5 Submerged exposure	33
3.7.6 Cell viability	33
3.7.7 Enzyme-linked immunosorbent assay	34
4 Results and discussions	35
4.1 Exposure of humans via inhalation	35
4.1.1 The pilot study	35

4.1.2	The main study	36
4.2	Thresholds for odor and lateralization	39
4.2.1	Validation of our olfactometer.....	39
4.2.2	Odor thresholds	39
4.2.3	Lateralization thresholds	41
4.3	Exposure of mice to acrolein.....	42
4.3.1	Branchoalveolar lavage.....	42
4.3.2	Markers of inflammatory and oxidative stress markers.....	42
4.3.3	Markers of tissue injury/repair.....	44
4.4	Exposure of the airway mucosa model	46
4.4.1	Cell viability	46
4.4.2	Changes in the levels of IL-8 and MMP-9	46
4.4.3	Changes in m-RNA levels	47
5	Concluding remarks	49
6	Future perspectives.....	50
7	Acknowledgments	51
8	References	54

LIST OF ABBREVIATIONS

VAS	Visual Analogue Scale
ALI	Air-Liquid Interface
EMG	Electromyography
CGRP	Calcitonin Gene Regulated Peptide
Sub P	Substance P
EPA	Environmental Protection Agency
ACGIH	American Conference of Government Industrial Hygienists
PM 2.5	Particulate Matter 2.5
DALY	Disability Adjusted Life Year
COPD	Chronic Obstructive Pulmonary Disease
ROS	Reactive Oxygen Species
NOAEL	No Observed Adverse Effect Level
LOAEL	Lowest Observed Adverse Effect Level
BAL	Branchoalveolar lavage
IARC	International Agency for Research on Cancer
HBEC	Human Bronchial Epithelial Cell
GO	Gene Ontology
OT	Odor Threshold
TRP	Transient Receptor Potential
TRPA1	Transient Receptor Potential Ankyrin 1
PBEC	Primary Bronchial Epithelial Cell
MCA	Minimum Cross Sectional Area
PEF	Peak Expiratory Flow
MRC-5	Medical Research Council cell strain-5
ELISA	Enzyme-Linked Immunosorbent Assay
IL-6	Interleukin-6
CRP	C-Reactive Protein
SAA	Serum Amyloid A
IL-8	Interleukin-8
CC-16	Club Cell

1 INTRODUCTION

1.1 ALDEHYDES

Aldehydes are a large class of electrophilic carbonyl compounds containing functional –CHO group to which humans are ubiquitously exposed [1]. In spite of the fact that such exposure poses a significant risk to health, the mechanisms underlying aldehyde toxicity remain poorly understood, at least in part because of the structural diversity of these compounds and their wide range of biological targets [2]. In addition to occurring naturally, aldehydes are derived from anthropogenic sources and even produced endogenously.

This family of chemicals can be divided into four major sub-classes on the basis of the presence of corresponding structure that incorporates additional functional moieties (Table 1).

Table 1: Classification, examples and uses of aldehydes

Classification of aldehyde	Examples of aldehydes	Industrial uses
Aliphatic aldehydes	Formaldehyde, Acetaldehyde and Hexanal	Monomer for polymer (resins), component of disinfectant, germicide, perfume, dyes
Aromatic aldehydes	Benzaldehyde and Vanillin	Chemical synthesis of components of dyes, perfumes and flavoring agents.
Unsaturated aldehydes	Acrolein, Crotonaldehyde	Chemical synthesis of, eg. methionine, sorbic acid and also used as algicide and herbicide.
α -Oxoaldehydes	Glyoxal, Glycolaldehyde, Glyoxylic acid	Leather tanning, cross linking of starch and for water treatment

Aldehydes can be detoxified in two ways:

1. Oxidation by aldehyde dehydrogenase to produce corresponding carboxylic acids.
2. Conjugation with sulfhydryl groups, especially in glutathione (GSH), which decreases glutathione levels and leads to oxidative stress or results in an suppression of aldehyde dehydrogenase.

In this thesis, the health effects of the aldehydes (acrolein, crotonaldehyde and hexanal) have been examined employing different experimental models. Chemical structures are presented below (Figure 1)

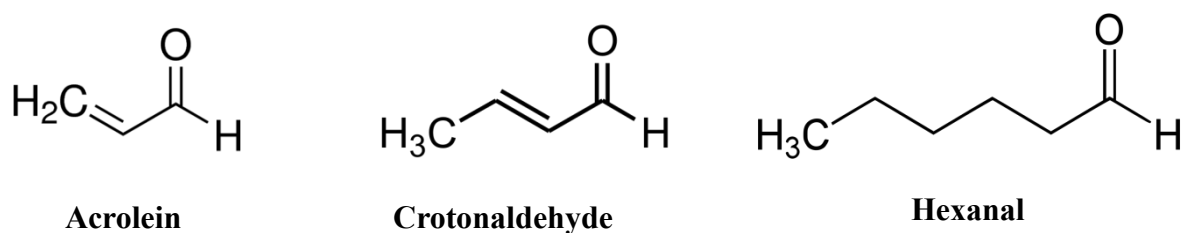

Figure 1: Chemical structures of aldehydes

1.1.1 Acrolein

1.1.1.1 Occurrences and levels of exposure

Acrolein (2-propenal), a reactive α , β unsaturated aldehyde is produced upon combustion of wood, plastic, gasoline, diesel fuel or paraffin wax, as well as in connection with smoking and cooking [3-6] (Figure 2). This compound is also produced to a lesser extent through biological process in higher organisms, and by human and microbial activities [7].

Acrolein is considered to pose one of the greatest non-cancerous health risks of all hazardous air pollutants [8]. Extensive increases in the incidences of chronic lung diseases, including childhood asthma, chronic bronchitis, and chronic obstructive pulmonary disease (COPD), during the past 15 years have led to considerable focus on the quality of indoor air [9, 10]. Especially, since inhabitation of the United States and Europe spends approximately 90% of their time indoors. While there is abundant data on common pollutants such as formaldehyde and carbon monoxide, very little is presently known about the indoor sources, levels, and fate of acrolein and other aldehydes. Indoor levels of acrolein have been found consistently to be higher (0-29 $\mu\text{g}/\text{m}^3$) than outdoors [11, 12]

The levels of acrolein in kitchen air vary in connection with the heating of oils and fats, having been reported to be in Norwegian restaurant kitchens approximately 0.004 ppm (0.0-0.013 ppm) [13] and 0.03- 0.26 ppm in Finnish restaurants [14]. In addition, levels of acrolein were approximately 0.004 ppm in connection with food processing; 0.008 ppm in bakeries [14] and more than 44 ppm during fires [15] have been reported. Firefighters have been exposed to concentrations as high as 3 ppm [16].

Little is presently known about the acute health effects of acrolein on human. A limited early investigation from the 1970's revealed that exposure to approximately 0.17 ppm for, few minutes to causes mild eye irritation, which becomes even more pronounced at 0.26 ppm [17]. Among 1192 substances in indoor air, particulate matter (PM 2.5), acrolein and formaldehyde have been listed as exerting the greatest cumulative impact on health in the United States, Whereas, the overall non-cancer impact of acrolein is estimated to result in 47 DALYs (Disability Adjusted Life Years) per 1000 residents annually [5]. Similarly, in Japan among 93 substances in indoor air, formaldehyde and acrolein were considered to be associated with the highest risk [18]. However, such calculations are highly uncertain, since very few measurements of air levels are available and extrapolating from high to low dose is problematic. Elevated levels of metabolites derived from acrolein and crotonaldehyde have

been detected in non-smoking Asian women who regularly cook wok and a direct relationship between frequency of wok cooking and exposure to airborne aldehydes has been proposed [19].

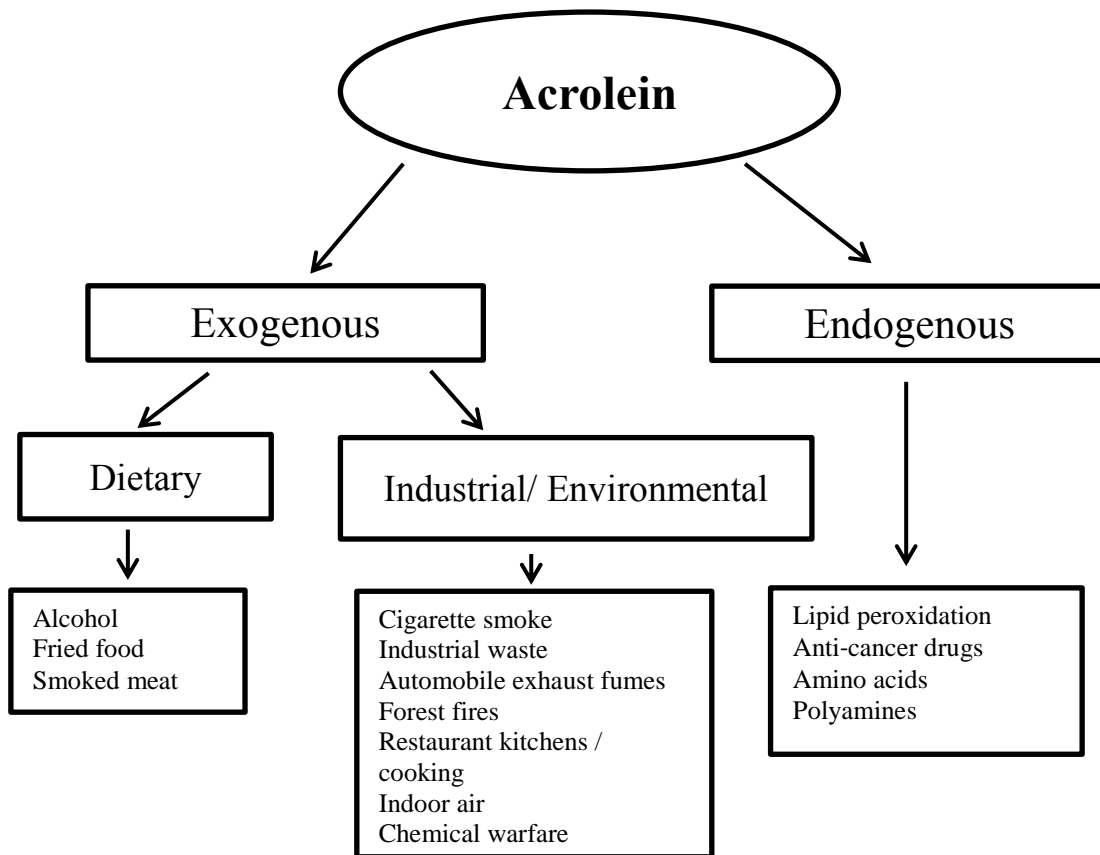

Figure 2: Exposure sources of acrolein

1.1.1.2 Health effects of acrolein

Acrolein is a risk factor for many diseases occurring throughout the body, including chronic pulmonary disease, airway neurogenic inflammation, neurodegenerative disorders, cardiovascular disease, diabetes mellitus, neurohepato and nephrotoxicity (Figure 3). Because of its simple structure and volatility, acrolein quickly crosses the plasma membrane of cells and causes a variety of adverse intracellular effects, including mitochondrial and death receptor pathways for apoptosis and necrosis [20-22]. Furthermore, oxidative stress is induced by acrolein [23-26], by binding to DNA and proteins. Such processes can lead to, mitochondrial disruption, membrane damage, endoplasmic reticulum stress and immune dysfunction (Figure 3, [27]).

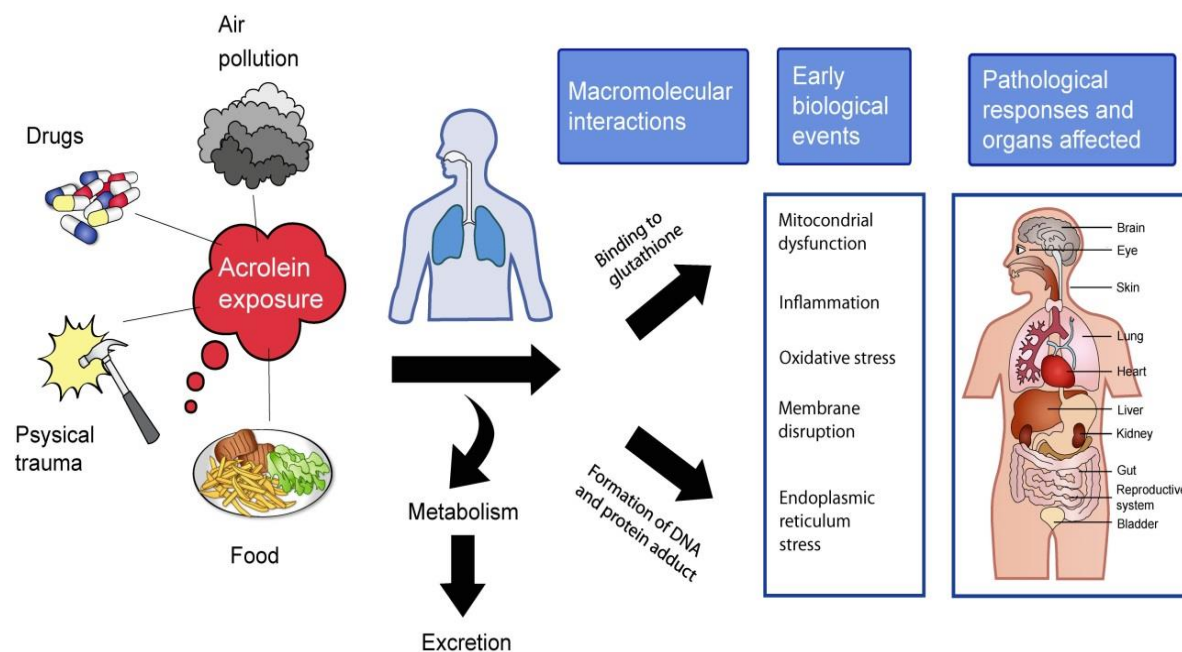

Figure 3: Mechanisms of underlying acrolein toxicity

As a strong electrophile, acrolein has great affinity for nucleophiles. A few such nucleophile groups are the sulfhydryl group of cysteine, imidazole group of histidine and amino group of lysine. The most significant interactions between acrolein and cellular molecules involve proteins and tri-peptides such as glutathione, which is required for the maintenance of redox homeostasis [28]. Acrolein undergoes nucleophilic Michael addition to form adducts or Schiff base cross-links [29, 30], with susceptible amino acid residues that play important enzyme catalysis, redox signaling, production of reactive oxygen species (ROS) and cellular buffering. Thus, adduction by acrolein may significantly alter in protein functions and disrupt the intracellular thiol redox equilibrium.

Furthermore, acrolein binds to DNA to form cyclic adducts and crosslinks [31-36]. In particular, this aldehyde reacts rapidly with deoxyguanosine (dG) to produce two exocyclic DNA adducts, α - and γ -hydroxy-1, N²-propano-2'-deoxyguanosine (α -HOPdG and γ -HOPdG). If not repaired quickly, such DNA adducts may lead to mutations. Suggesting may contribute to the process of carcinogenesis [34] or other diseases [27].

1.1.2 Crotonaldehyde

1.1.2.1 Occurrence and levels of exposure

Although chemically similar to the acrolein, crotonaldehyde is less toxic, but still considered to be an important environmental and industrial pollutant [37]. Environmentally,

crotonaldehyde is produced by combustion of fossil fuel, tobacco and wood, as well as heating of cooking oil. This aldehyde is an odorous constituent in aircraft emission, has been detected at high levels in cigarette smoke (10-228 µg/cigarette [38, 39] and smoke from wood fires (6-116 mg/kg wood [40]). Industrially, crotonaldehyde is primarily used in manufacture of chemicals such as butanol and sorbic acid, which constitute one of major sources of human occupational exposure. Moreover, crotonaldehyde is present naturally in small amounts in many food items, the air in pine and deciduous forests in Europe and gases emitted by volcanoes [39]. Since it binds to guanine residues in DNA and also modulates certain immunological functions, the Environment Protection Agency (EPA) has classified this aldehyde as a possible carcinogen. Crotonaldehyde is highly irritating to the eyes, nose, mucous membranes, upper respiratory tract and skins of humans and other animals [41-43].

1.1.2.2 Health effects of crotonaldehyde

In rodents crotonaldehyde causes gastric, respiratory and hepatic toxicity. As well as being involved in hepatocarcinogenesis [44]. On the basis of the hepatocellular carcinomas and hepatic neoplastic nodules it evokes in male rats, crotonaldehyde has been classified as a Group 3 carcinogen by the International Agency for Research on Cancer (IARC). However, data on its potential human carcinogenicity are lacking. The potential carcinogenicity of crotonaldehyde is supported by its genotoxicity *in vitro* and it is also a suspected metabolite of N-nitrosopyrrolidine, a probable human carcinogen [45].

Crotonaldehyde is a highly selective respiratory toxic and that may lead to chronic pulmonary diseases by altering a variety of cell signaling cascades, including those involved in inflammatory responses. Little has been known about the possible induction of oxidative stress by this compound. There is some evidence that with its electrophilic olefin and carbonyl groups, crotonaldehyde is highly active towards cellular nucleophiles generation, e.g., DNA and protein adducts [46, 47]. Other studies show that α , β -unsaturated aldehydes can inhibit cytokine gene expression by alkylating NFkappaB1 [48, 49] but, there is presently little information concerning alteration of gene expression by crotonaldehyde. As an aldehyde, this compound can be detoxified by hydrogenation or oxidation.

The few investigations of global transcriptional responses to exposure to crotonaldehyde reported to date have been performed on THP-1 cells (Human monocyte leukemia cell line), human bronchial epithelial cells (HBECs) and alveolar macrophages. In the case of HBECs, the genes whose expression is altered code for protein involved in oxidative stress, caspase-dependent apoptosis and cytokine signaling [50, 51]. Crotonaldehyde induces apoptosis,

immunosuppression and release of IL-8 in alveolar macrophages [52, 53]. Lee and colleagues (2011) reported that in human umbilical vein endothelial cells crotonaldehyde induces HO-1 expression, an adaptive response to oxidative stress and mediated by the PKC- β -p38MAPK-nrf2-HO-1 pathway [54]. Recently, crotonaldehyde has also been found to mediate anti-apoptotic effects in human endothelial cells by upregulating heat shock protein 72 (hsp 72) [55]. Nonetheless, the mechanism underlying the adverse effects of this aldehyde on respiratory health, remain to be elucidated.

1.1.3 Hexanal

1.1.3.1 Occurrences and exposure levels

Hexanal a colorless liquid that smells like green grass is present naturally in many fruits and vegetables. This alkyl aldehyde is also found in human biofluids (milk, blood, Saliva) [56] and is a major indoor air pollutant [57]. In addition, this compound is present in volatile organic mixtures used as flavoring additives in cigarettes, fragrances and the food industry, moreover, is emitted in large amount from stored wood pellets and fiber boards of medium density [58]. It is also used in the synthesis of plasticizers, rubber chemicals, dyes, synthetic resins and insecticides. Hexanal is generated through oxidative cleavage of ω -6 unsaturated fatty acids, such as linoleic or arachidonic acid [56].

Hexanal can initiate mutagenesis and carcinogenesis, regulate growth and signaling; and mildly irritating to the eyes and nose [58]. As a breakdown product of the oxidation of linoleic acid this aldehyde arises in connection with lipid peroxidation and alteration in flavor of food. The "cardboard-like" flavor of hexanal is frequently associated with spoiling dehydrated milk products and this compound has been proposed as a potential marker of milk quality [59].

1.1.3.2 Health effects of hexanal

Hexanal may exerts adverse health effects on humans. When 12 healthy human volunteers were exposed to 0, 2, and 10 ppm of hexanal for 2 hours in a controlled chamber, ratings of blinking frequency were significantly increased at the highest dose [58]. No changes on pulmonary function and nasal swelling were observed except for a non-significant tendency towards nasal obstruction at 10 ppm. Nor were there any clear effects on the plasma inflammatory markers (C-reactive protein (CRP) and interleukin-6 (IL-6)). These

investigators concluded that, two hours of exposure to 10 ppm of hexanal results in mild irritation, with no such impact at 2 ppm [58].

Moreover, 0.1% hexanal depresses the motility of human spermatozoa but without ever causing complete immobility [60]. In addition, low molecular weight aldehydes, including hexanal, may interfere with cholesterol transport and gap junctional intercellular communication in human smooth muscle cells [61].

Exposure to a concentrated vapor of hexanal (2000 ppm) for 1 hour or 4 hours results in mortality in rats and is cytotoxic towards the hepatocytes of these animals [62]. Rats consuming diets containing hexanal for three weeks exhibited attenuated serum cholesterol and triglycerides levels. In addition, hexanal stimulates dopamine release, but does not inhibit dopamine uptake in the brain striatum of rats and alters length of time during which virgin females display maternal crouching. In one study on mice hexanal influenced maternal behavior and led to neonatal death [63]. Hexanal is also mutagenic towards mammalian cells, producing single-strand DNA breaks or lesions which are converted to such breaks by alkali [64].

The mechanisms underlying of hexanal toxicity is poorly defined. When Fisher 344 rats were exposed by inhalation exposure to 0, 600, 1000, and 1500 ppm of hexanal vapors for 4 hours/day, 5 days/week for 4 weeks and alterations in the expression of 56 genes in were revealed by microarray based genome wide expression analysis [65]. Of these 56 genes, 11 demonstrated dose-dependent changes and the expression of 10 was downregulated and the other upregulated at least 1.5-fold ($p < 0.05$). Cho and coworkers found by comparative analysis of toxicogenomic databases (CTD) analysis that five of these 11 genes (CCL12, DDIT4, KLF2, CEBPD, and ADH6) are linked to diverse categories of disease such as cancer, respiratory tract disease, and immunological diseases all known to be caused by volatile organic compounds (VOCs). Gene ontology (GO) analysis and mi-RNA and m-RNA interaction analysis of A549 (human alveolar cells) led to the conclusion that the key biological process affected by exposure to hexanal are involved in neurological processes, development of the immune system, cell activation and cell-cell signaling [66]. Accordingly, dose dependent alterations in gene expression can help to predict hexanal induced pulmonary toxicity and carry out relative risk assessments.

1.2 TEST SYSTEMS

1.2.1 Human exposure by inhalation

The general population is exposed to aldehydes by inhalation, ingestion, and dermal contact with food and other items. Aldehydes are common indoor and outdoor pollutants, so that exposure via inhalation route is common. On the basis of our previous experience of performing human exposure studies on different solvents [58, 67-70], we have exposed humans to vapors of acrolein by inhalation in an exposure chamber (Figure 4, page 24). After such exposure to vapors of solvents or clean air (as a control exposure), acute effects on human healthy volunteers could be assessed. One major advantage of this type of exposure is that individuals serve as their own controls, so that even small effects can be detected. These inhalation exposure studies may provide information concerning threshold levels (NOAEL, no observed adverse effect level and LOAEL, lowest observed adverse effect level) for acute irritation and inflammation of solvents and thus improve the scientific basis for setting exposure limits in our own country as well as within the entire European Union.

1.2.2 Thresholds for odor and lateralization

Sensory irritation is a general term, including both the irritation of eyes and the upper airways. The sensory irritants acrolein and crotonaldehyde excite peripheral nerves to induce pain and respiratory irritation [71] and such neuronal activation is immediate. Stinging pain and lachrymation in the eyes results from activation of the trigeminal nerve ending in the cornea by these aldehydes. Whereas, stimulation of trigeminal nerve endings in the nose, as well as vagal laryngeal sensory nerve endings triggers upper airway irritation, pain, sneezing, coughing and nasal discharge [72]. On the other hand, hexanal, is an indoor air irritant but not a strong odorous irritant [73], is very unlikely to produce sensory irritation at the levels present in indoor air.

Most aldehydes have very strong odor, which limits risk evaluation based on the quality or intensity of odor. Indeed, detection of odor correlates poorly with toxicology and the relationship between odor and irritation is unclear with many substances eliciting odor at very low concentrations and irritation at very high concentrations. The odor threshold (OT), i.e., the lowest concentration of a compound which can be perceived by the human sense of smell, has proven to be difficult to determine for individuals with normal olfaction. The OT of a chemical depends on its shape, polarity, partial charges and molecular mass.

Odor interferes with the measurements of irritation, presumably because of ambiguity regarding the point at which an odor itself becomes an irritation and the sensation takes on an irritation character via stimulation of the trigeminal nerve. The lateralization threshold (LT) is the concentration at which individual can discriminate which nostril is being exposed, which requires sensory stimulation of the trigeminal nerve.

1.2.2.1 Involvement of the TRPA1 in toxicological injury

Transient receptor potential (TRP) ion channels located in the plasma membrane and membrane of intracellular organelles, participate in maintaining the homeostasis of intracellular Ca^{2+} [74, 75]. The 28 known TRP channels are grouped into seven subfamilies: TRPC, TRPV, TRPM, TRPP, TRPML, TRPA, and TRPN) and each sub-family includes one or more members [76].

Transient receptor potential ankyrin 1 (TRPA1), a cation channel is expressed in TRPV1-positive neurons of all sensory ganglions (trigeminal, vagal and dorsal root), a target for environmental irritants such as acrolein, crotonaldehyde, tobacco smoke, mustard gas and diesel exhaust fumes. For instance, these receptors are the neuronal target for isothiocyanate and thiosulfinate compounds, which are present in mustard oil and wasabi. Acrolein activates both human and rodent TRPA1 [72] and crotonaldehyde also acts as an environmental agonist of this receptor [77].

As described earlier, acrolein and crotonaldehyde both are strong electrophiles and as such they bind to the cysteine residue of TRPA1, thereby opening of cation channel and allowing calcium to enter which leads to neuronal activation and secretion of substance P (SubP) and calcitonin gene regulated peptide (CGRP). This sequential process aggravates both local and coordinated inflammatory responses, including elevated blood flow, vascular permeability and sensation of pain [77]. SubP and CGRP are responsible for these highly localized effects of TRPA1. Thus α , β -unsaturated aldehydes stimulate TRPA1 mediated inflammation, which may contribute to cardiopulmonary toxicity [78]. Oxidative stress, a hallmark of most acute and chronic inflammation of the airways, also excites sensory nerve fibers in the airways, resulting in respiratory depression [72, 77]

1.2.3 Mice exposure by inhalation

Animal models are frequently used as an alternative to investigate the mechanisms and progression of chronic lung diseases in humans. It is very unlikely that a single animal model will provide information regarding morphological and functional features of diseases.

However, laboratory animals (guinea pig, rat and mouse) are employed to describe underlying mechanism for lung diseases. Mouse is the most widely used species, mainly because of the availability of transgenic animals. We employed seven inbred mice strains to better understand their susceptibility and pulmonary oxidative stress, pro-inflammation and tissue injury caused by sub-chronic exposure to acrolein (Paper IV). The selection criteria are based on their availability and frequent use in respiratory research.

1.2.4 *In-vitro* test system

Researches are attempting to adhere to the 3R principals of reduction, refinement and replacement of animal experimentation and thus feasible alternatives are being developed. Submerged monocultures of transformed and immortalized cell lines have provided important tools not only for unraveling mechanisms of toxicity, but also for characterizing thousands of pharmaceutical compounds over the past decades. Despite this extensive usefulness, more sophisticated models that mimic the physiological situation more closely and include two or more cellular lineages of epithelial and immune cells, are desirable [79].

Fibroblasts play an important role in epithelial cell function, contributing to the spatial distribution required for long-term maintenance of mucociliary phenotype [80]. In recent years, several approaches to optimal inclusion of fibroblasts in 3D airway models have been proposed [81]. Indeed, Pezzulo and colleagues (2011) have shown that fibroblasts are required for the differentiation of epithelial cells and by embedding different immune components to dual or triple co-cultures pseudo-tissues like structures can be achieved [82]. This approach has been employed to characterize mechanism of immune defense and elucidate paracrine signaling by cytokines on the epithelium [83].

The cell types available for modelling the human respiratory system include primary cells from humans or animals and submerged immortalized cell lines (BESE-2b, 16-HBE, A549). Unfortunately, the extensive recent findings from submerged cultures are not directly applicable to humans, because in such submerged systems cells fail to differentiate. To recreate the pseudostratified epithelium *in vivo*, primary bronchial epithelial cells (PBECs) have been cultured at air-liquid interface (ALI) [82, 84] an arrangement recapitulates the conditions present in the human airway and promotes mucociliary differentiation.

To mimic the *in vivo* situation, PBECs are seeded on either collagen based or permeable inserts. Routinely, these cells are allowed to grow submerged until they become confluent, and then the media is removed from underneath to grow the cells at air-liquid interface (ALI)

until they fully differentiated [85]. Such models of airway mucosa contribute towards a unique opportunity to reduce and refine animal experimentation, while providing relevant insights on particle, gaseous inhalation toxicity and the integrity of the airway epithelium.

2 AIMS

The overall aim of the current project was to investigate the acute adverse effects, with primary focus on irritation and inflammation of acrolein and other aldehydes present in indoor environments.

Our specific aims were:

- To estimate the threshold levels for acute irritation of acrolein in human volunteers exposed via inhalation. (Paper I)
- To obtain insight into the thresholds for odor and irritation by acrolein, cotoanaldehyde and hexanal in human volunteers employing a novel olfactometer. (Paper II)
- To charecterize the sub-chronic pulmonary toxicity in induced in seven inbred strains by acrolein. (Paper III)
- To assess the inflammatory responses and cytotoxicity of a sophisticated mucosa model including PBECs exposed to vapors of acrolein, cotoanaldehyde and hexanal, and to compare the levels of m-RNA encoding inflammatory markers at an air-liquid and cells from submerged culture. (Paper IV)

3 MATERIALS AND METHODS

This section summarizes several novel methods and experimental models employed here to examine the acute health effects of acrolein, crotonaldehyde and hexanal, with more detailed descriptions in the accompanying papers and manuscript. Two studies were performed on human healthy volunteers, one on inbred mice exposed to acrolein, and the fourth with PBECs from humans.

3.1 HUMAN VOLUNTEERS

Subjects were recruited by advertisement at Karolinska Institutet, Stockholm University, the Royal Institute of Technology, and on a web page designed for recruitment of research volunteers. The inclusion criteria were; an age between 20-50 years, good health, non-smoker and non-pregnant. Prior to exposure a medical examination of each participant and a pregnancy test on all of the women were performed. The volunteers were informed about the design of the studies, possible hazards, and their right to immediately and unconditionally withdraw from the study. Both of these studies (Papers I & II) were performed in accordance with the Helsinki declaration and pre-approved by the Regional Ethical Review Board in Stockholm. To ensure that the subjects had a normal sense of smell, they underwent an anosmia screening test based on the Sniffing Sticks, before participating in the study on odor and irritation thresholds.

3.2 EXPOSURE OF HUMANS VIA INHALATION (PAPER I)

3.2.1 The exposure chamber

Volunteers were exposed in a 20-m³ dynamic chamber of glass and inert material with monitoring of the temperature, relative humidity and levels of carbon dioxide (Figure 6). Vapors were generated by injecting liquid acrolein (0.1 %) and ethyl acetate (EA) (used to mask the odor of acrolein in the main study) into the inlet air with a high pressure chromatography piston pump and subsequent dispersion through the chamber ceiling. To assess the odor and irritation of acrolein and set an exposure limits for main study a pilot study was performed. In the pilot study, the volunteers were exposed to increasing concentrations of acrolein (0.02, 0.04, 0.07, 0.1, 0.2 and 0.3 ppm) for 10 minutes.



Figure 4: The human exposure chamber

3.2.2 Rating of symptoms

The symptoms related to the eyes, nose throat, smell and CNS listed below were rated on visual analog scales (VAS) as follows:

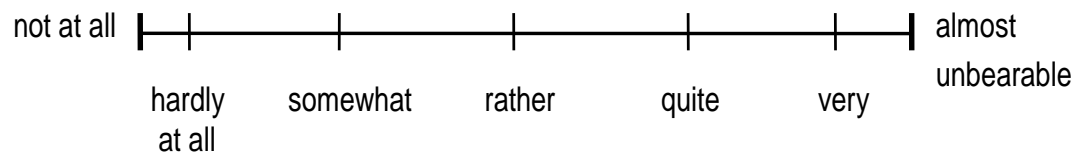

1. Discomfort in the eyes: burning or irritation
2. Discomfort in the nose: burning, irritation, or runny nose
3. Discomfort in the throat or airways
4. Breathing difficulty
5. Smell
6. Headache
7. Fatigue
8. Nausea
9. Dizziness
10. Feeling of intoxication

3.2.3 The frequencies of blinking and breathing

As a measure of eye irritation, blinking frequency of the left eye was monitored by electromyography (EMG) via three skin electrodes, two on the M. orbicularis oculi and a reference electrode on the cheek bone (Figure 5). Breathing frequency was measured by respiratory inductive plethysmography employing a flexible belt mounted around the volunteer's chest (Figure 5).

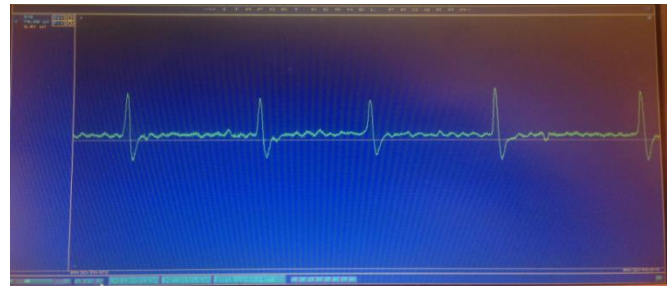

Blinking Frequency

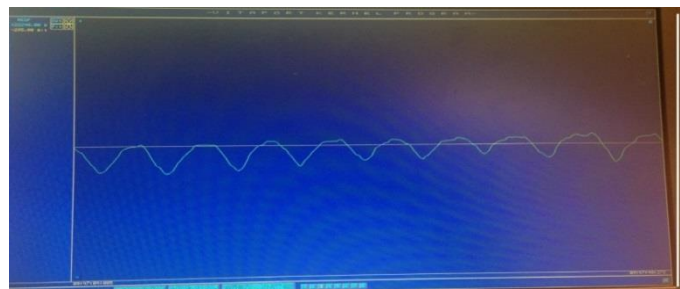

Breathing Frequency

Figure 5: (Left) Volunteer equipped with EMG electrodes for recording of blinking frequency, an inductive flexible chest belt for recording of breathing frequency and a data logger (black box). (Right) Recordings of the blinking and breathing frequencies

3.2.4 Pulmonary function

Pulmonary function tests were performed with a spirometer and accompanying computer software. The parameters measured included vital capacity (VC), forced vital capacity (FVC), forced expiratory volume in 1 s (FEV1), peak expiratory flow (PEF) and forced expiratory flow at 5%, 50%, and 75% of FVC (FEF25, FEF50, FEF75) (Figure 6).

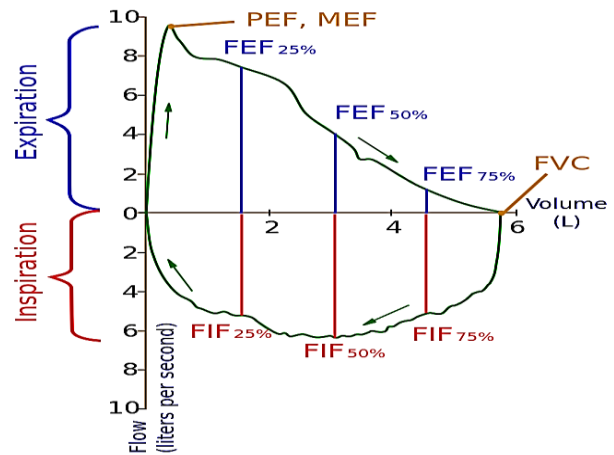
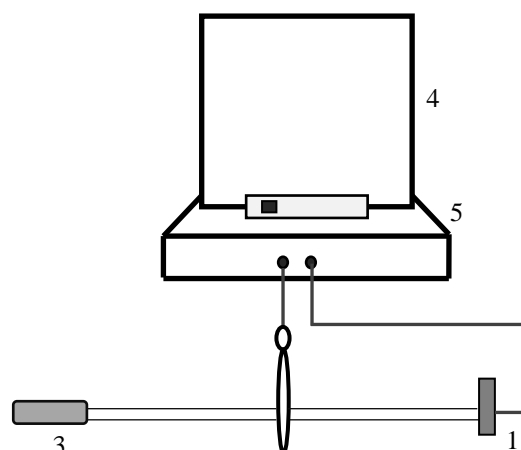
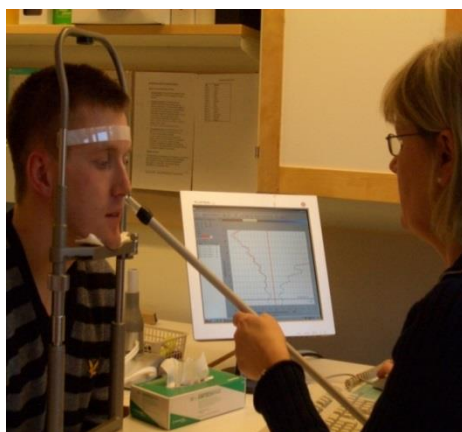

Figure 6: Spirometry measurements

3.2.5 Nasal swelling

To assess the effect of acrolein on nasal swelling, the minimal cross-sectional area (MCA) and volume of the nose were measured by acoustic rhinometry at two distances (0 to 22 mm and 23 to 54 mm) from the opening of the nose (Figure 7). This approach evaluates nasal obstruction by analysing reflections of a sound pulse introduced into the nostrils.



- 1 Sound generator
- 2 Sound tube
- 3 Nose piece
- 4 Computer
- 5 Amplifier

Figure 7: Measurement by acoustic rhinometry

The blocking index (BI), a measure of the nasal airway resistance, was also calculated as the difference between the PEF values for the mouth and nose, divided by the mouth PEF value [86].

3.2.6 Markers of inflammation and coagulation in blood and induced sputum

The levels of interleukin-6 (IL-6), C-reactive protein (CRP), serum amyloid A (SAA), fibrinogen, factor VIII, von-Willebrand factor (vWF) and club cell (CC16) in blood were analyzed. Sputum was induced only with case of control and high-level exposure to acrolein, was examined with the respect to the cells present and with measurement of IL-6 and IL-8 levels. For a more detailed description of these methods please see Paper I.

3.3 THRESHOLDS FOR ODOR AND LATERALIZATION (PAPER II)

3.3.1 The olfactometer

The thresholds of aldehydes for odor and irritation were determined with a novel, inexpensive olfactometer consisting of syringes attached to pumps, each connected to a Tedlar bag containing a specific concentration of the test chemical in air (Figure 8). To determine the threshold for the detection of odor, a small amount of air (with or without aldehyde) was pumped into the nose piece and the volunteers were asked to decide whether he/she was inhaling aldehyde vapor or clean air. To determine the lateralization threshold clean air was pumped into one nostril and aldehyde vapor into the other, starting at the odor threshold. The volunteer then decided in which nostril the aldehyde was present. To determine the concentration range to be employed, a pilot study involving a wide range of concentrations was performed and the range that included most of the volunteers tested were selected for use the main study. Further description of the olfactometer, as well as of how the vapors were generated and tested is presented in Paper II.

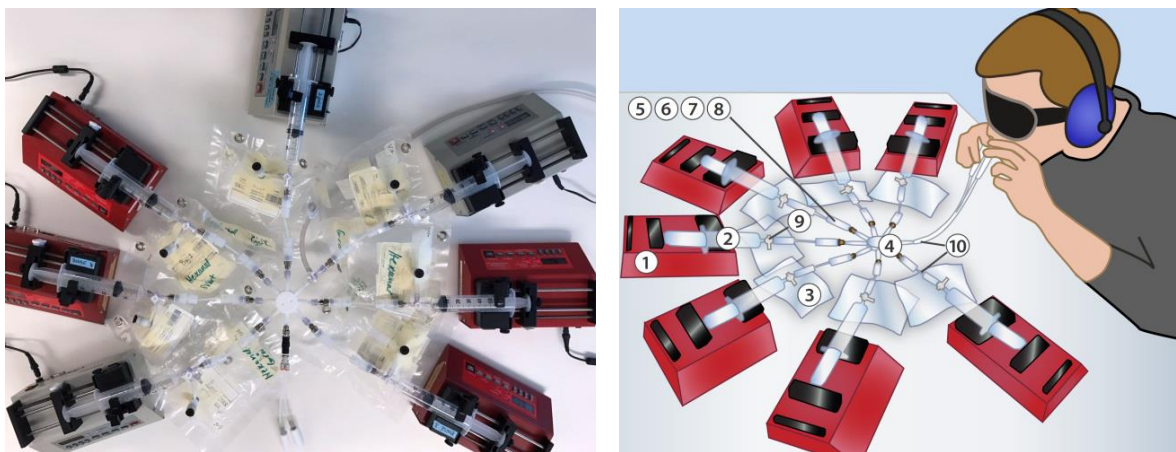

Figure 8: The olfactometer

(Components of olfactometer are: 1=Syringe pump, 2=Syringes, 3=Teddlar bags, 4=Multiport connector, 5=Adapter, 6=Luer, 7=Female Luer, 8=Adapter pipe, 9=Stopcock, 10=Teflon tubes). Adapted from Paper II, with permission from publisher.

3.3.2 Confirmation of the odor threshold using amber bottles

To confirm, the findings of our novel olfactometer developed in-hose, the odor threshold for hexanal was also determined using amber bottles. Ten of the previous volunteers sniffed air from a bottle (60 ml) containing 10 ml of diluted hexanal with the same concentrations as in the case of olfactometer, as confirmed by GC analysis of the three highest concentrations, starting with lowest concentrations. For further details please see the Method and Material section of Paper II.

3.4 EXPOSURE OF MICE TO ACROLEIN (PAPER III)

The sub-chronic pulmonary toxicity induced by acrolein in seven female inbred mice strains 129S1/SvImJ, A/J, BALB/cByJ, C3H/HeJ, C57BL/6J, DBA/2J and FVB/NJ mice (age: 12-14 weeks) was examined. These mice were obtained from the Jackson Laboratory (Bar Harbor, ME, USA) and housed under specific pathogen-free conditions at the animal facility of the New York University Medical School (New York, NY, USA), with food and water provided *ad libitum*. This study was approved by the Institutional Ethical Board (reference no. 100684).

3.4.1 Mice exposure

Mice (one group 5 for each strain) were subjected to whole-body exposure to filtered air with and without acrolein in 1.3-m³ stainless steel inhalation chambers for 6 hours per day, 4 to 5

days per week for a total of 11 weeks. Acrolein gas was generated by passing charcoal and HEPA-filtered air over acrolein in a glass flask and the chamber concentration target of 1 ppm with a Miran 1A. The actual chamber concentration was 1.03 ± 0.03 ppm (mean \pm SD). To obtain tissue for mRNA and protein analysis the diaphragm was punctured, the chest cavity opened and the lungs excised, frozen in liquid nitrogen, and stored (-80° C).

3.4.2 Bronchoalveolar lavage

Bronchoalveolar lavage (BAL) was performed immediately after exposure by cannulating the trachea and infusing the lungs two times with 1.2 ml of Dulbecco's phosphate buffered saline (PBS) without calcium and magnesium. Analysis of BAL cell differentials and BAL total protein content was performed. A detailed description is presented in Material and Method section of Paper III.

3.4.3 Preparation of lung homogenate

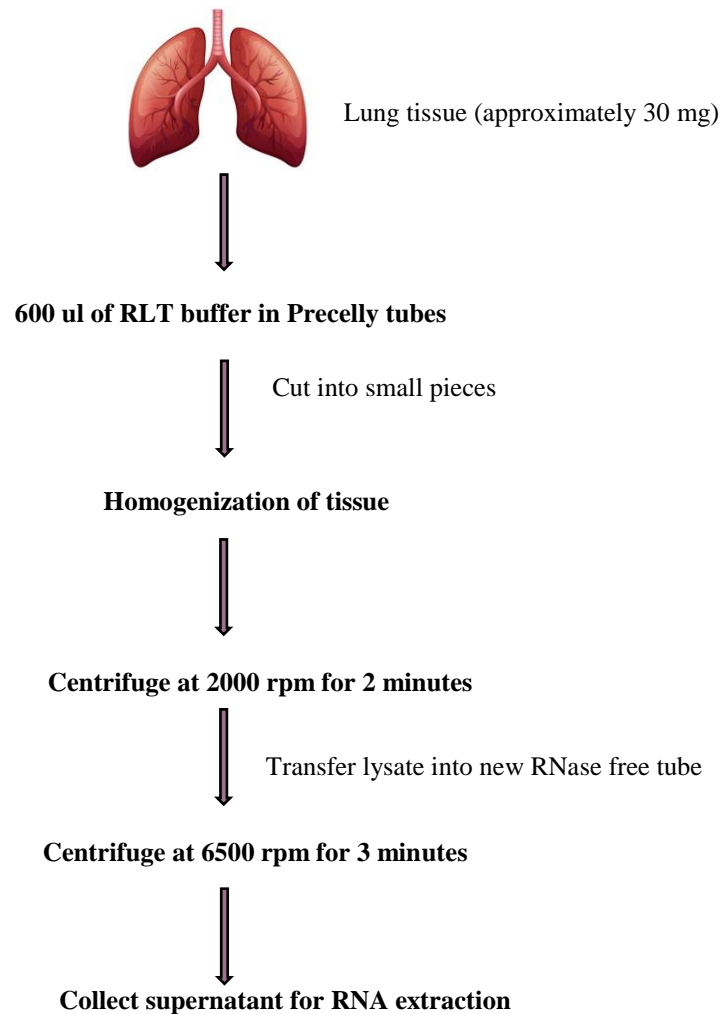

Figure 9: Preparation of lung homogenate for extraction of RNA

3.5 RNA/CDNA SYNTHESIS

RNA was extracted from the lysed airway mucosa model (Paper IV) and mouse lung samples were extracted in accordance with the manufacturer's instruction using total RNA isolation and reverse transcription and qRT-PCR performed by using RNeasy Mini Kit (Quiagen). The High Capacity RNA-to-cDNA kit (Applied Biosystems) was utilized for reverse transcription and the concentration of mRNA were subsequently assessed by spectrophotometrically (260/280 nm ratio, NanoDrop 1000, Thermo Scientific).

3.6 MARKERS ANALYZED WITH THE REAL-TIME POLYMERASE CHAIN REACTION

The primers used for gene amplification are specified in Table 1 (Material and Method sections of Papers III and IV). *β-Actin* was used as a housekeeping gene for normalization of the relative levels of mRNA. In the lungs of the inbred strains of mice the levels of mRNA encoding the pro-inflammatory markers *Nfkb*, *Tnfa*, *Il6*, *Il17b*, *Cxcl1*, *Mip2* the markers of oxidative stress *Gp1*, *Gpx3*, *Sod3*, *Ho1* and markers of tissue injury/repair *Mmp9/Timp1* were analyzed.

In addition, levels of mRNA encoding the pro-inflammatory markers IL8, MMP9, NFKB, TNFA, IL6 and the markers of oxidative stress HMOX1 were determined in the PBEC-ALI and PBEC-Submerged.

3.7 EXPOSURE OF THE AIRWAY MUCOSA MODEL (PAPER IV)

3.7.1 Primary bronchial epithelial cells

PBEC, obtained from Karolinska Hospital in connection with lobectomy, were isolated and cultured according to Strandberg and colleagues (2007) with certain modifications [87]. This study received ethical approval from Karolinska Hospital (KI forskningsetikkommitte Nord, Dnr.99-357).

3.7.2 Culturing human lung fibroblasts

Medical Research Council cell strain-5 (MRC-5, lung fibroblasts) cells, originally derived from a 14-week male fetus, were obtained from American Type Cell Culture (passage 27 was used), cultured submerged in a Petri dish and placed upside down on inserts to construct the mucosa model (Figure 10 B).

A. Timeline

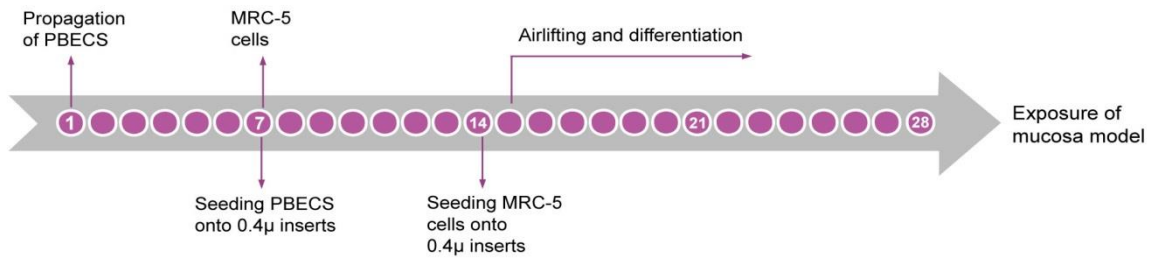

B. Procedure

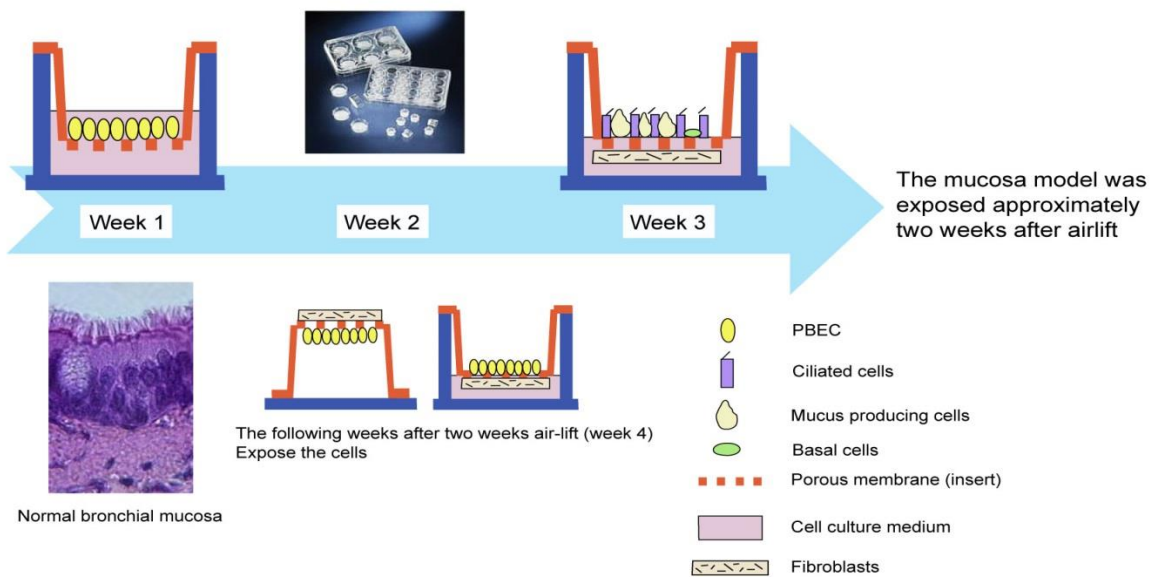

C. Exposure system, adapted from Paper IV with permission from publisher.

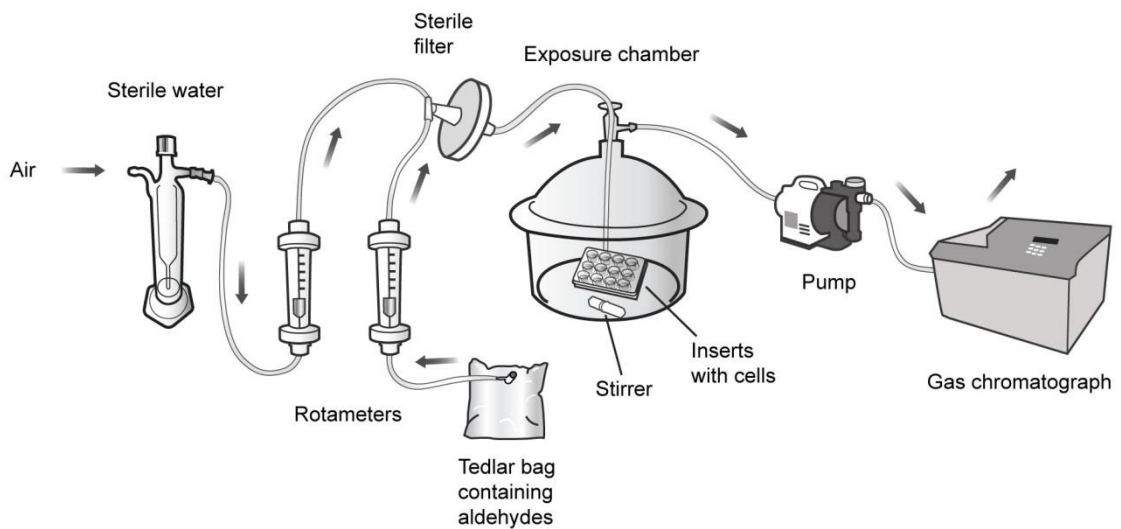

Figure 10: The airway mucosa model and exposure system

3.7.3 The chamber for exposure of cells

The mucosa models were exposed to aldehyde vapors (generated in a 10-liter Tedlar bag) in a small exposure chamber of glass (Figure 10 C). The bag was attached to the exposure chamber and the aldehyde vapor was pumped through at a flow rate of 0.4 liter/minute. To ensure even distribution, a magnetic stirrer was placed at the bottom of the chamber. A sterile filter was attached to the inlet tube. The humidity in the exposure chamber was maintained at 45-50% by a humidifier connected to the inlet air.

The mucosa models were introduced into this chamber immediately prior to exposure. The outlet of the chamber was connected to a gas chromatograph for analysis of the actual concentration in the chamber air (Figure 10) five times during the 30-minutes exposure. For further details please refer to Paper IV.

3.7.4 Exposure at air-liquid interface

PBECs from three donors were exposed in triplicate to aldehyde vapors for 30-minutes, followed by incubation in the absence of aldehyde up to 24 hours. Control exposure to clean air without aldehyde was carried out (in an identical manner). Both the basal medium (BM) and apical medium (AM) were collected 8 and 24 hours post-exposure for analysis of IL-8 and MMP-9 levels by enzyme-linked immunosorbent assay (ELISA). On the basis of these findings gene expression was performed at 6 hours post exposure with the real time polymerase chain reaction (qRT-PCR). For a full description, please see Paper IV.

3.7.5 Submerged exposure

PBEC were grown on 24 well plates in keratinocytes serum free medium (KSFM) and at sub-confluence, exposed to acrolein, crotonaldehyde and hexanal for 30 minutes. Subsequently, the culture medium was replaced with new medium incubation continued up to 24 hours and gene expressions, IL-8 and MMP-9 release were determined with the qRT-PCR and ELISA, respectively.

3.7.6 Cell viability

The viability of the PBECs was tested at 8 and 24 hours after exposure by staining with Trypan blue 200 μ l of 0.4% in PBS for 1 minute, followed by washing with PBS, and evaluating of dye exclusion under a bright-field microscopy.

3.7.7 Enzyme-linked immunosorbent assay

IL-8 and MMP-9 were assayed with the Human CXCL/IL-8 duo set and Human MMP-9 duo Set (R&D Systems, Minneapolis, MN), respectively, in accordance with the manufacture's protocol. The limits of detections (LOD) were 31.2 and 15.6 pg/ml for IL-8 and MMP-9, respectively.

4 RESULTS AND DISCUSSIONS

In the following section, the results and discussions from the studies carried out in this thesis are presented.

4.1 EXPOSURE OF HUMANS VIA INHALATION

As a first step, a pilot study was performed to identify appropriate exposure levels for the main study.

4.1.1 The pilot study

The rating of smell increased immediately when the volunteers entered in the exposure chamber, even at a level of 0.02 ppm (median rating of 13 mm, Figure 11), a concentration lower than the 0.03 ppm reported previously (Sinkuvene 1970, cited in [88]) and higher than the 0.0036 ppm employed by Nagata (2003) [89]. Nagata's subjects were trained, which might explain their ten-fold greater smell sensitivity compared to naïve volunteers [89].

Since it was possible that, our volunteers detected odor while entering the chamber, simply because they were expected to smell acrolein, we compared the ratings of smell in the pilot and for the clean air the main study (3 minutes) and found that the median rating of odor in the pilot study was twice as high as compare to main study. Thus, we concluded that volunteers actually did perceive the odor of acrolein at 0.02 ppm. Increasing this level had no effect on their smell ratings, since humans adapt quickly to smell.

With respect to that the dose-effect relationship of irritation, i.e. a significant increase in throat irritation ($p= 0.006$) for the 50th percentile (median) and a tendency towards enhanced eye irritation ($p= 0.066$) for the 75th percentile (Figure 1 B and C; Paper I) were revealed by logistic quantile regression. This analysis also indicated a dose-effect relationship up to 0.3 ppm in the pilot study, in agreement with Weber-Tschopp and coworkers (1977) [17], who also observed throat irritation at 0.3 ppm. No other clear effects could be detected on other ratings.

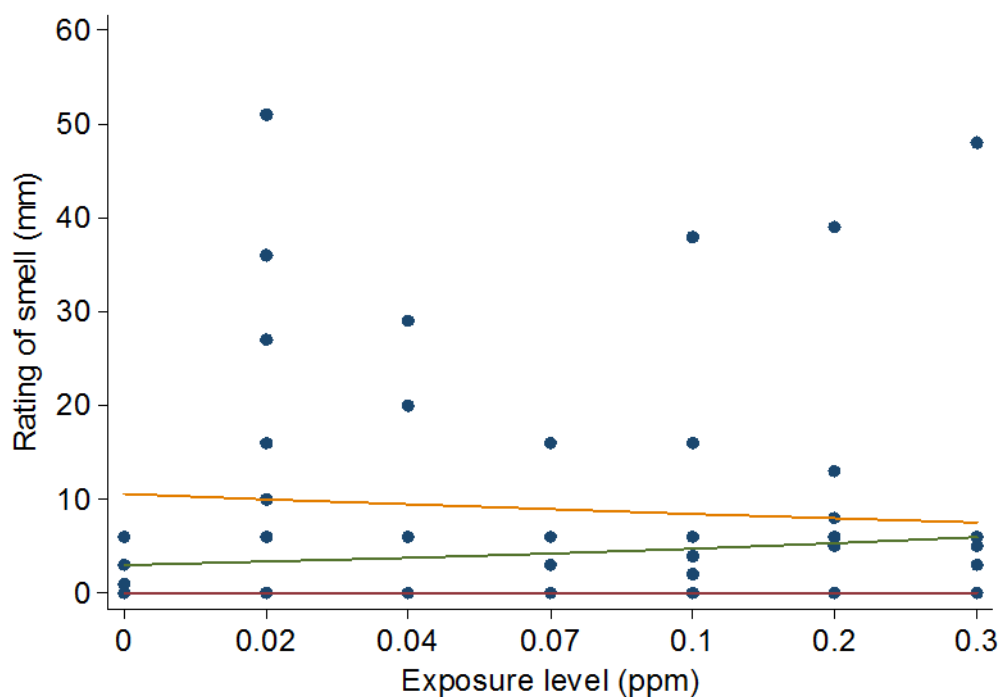

Figure 11: The relationship between rating of smell and the level of exposure. The curves represent the 25th, 50th (median), and 75th percentile and each dots represent individual ratings. Adapted from Paper I, with permission from publisher.

4.1.2 The main study

4.1.2.1 Ratings of symptoms

The rating of eye irritation increased slightly, but significantly during exposure to acrolein in a dose-dependent manner ($p < 0.001$, Friedman test), with a median value of 8 mm (slightly more than “hardly at all”) after 118 minutes at 0.01 ppm, with no influence of EA. This finding of eye irritation as a critical effect of acrolein exposure is in line with the observations of Weber- Tschopp and colleagues (1977), in connection with three scenarios for exposure to acrolein in which irritation was rated on the basis of questionnaire, frequency of blinking and respiration rate [17]. Three other studies that also document eye irritations following exposure to acrolein are limited by their use of much higher concentrations for shorter periods [90-92].

Development of sensory irritation is a complicated process with time that depends on the nature of test compound and such irritation may disappear with time or even re-appear after a short period. However, within a given time frame (several minutes and longer) sensory irritation is more heavily dependent on the concentration than the duration of exposure [93]. Although our experiment which suggests that the rating of eye irritation after 3 minutes was

only marginally higher than pre-exposure ratings, these ratings continued to rise with the time, especially during the first hour of exposure to acrolein. Accordingly, Weber-Tschopp and colleagues (1977) reported an elevation in eye irritation during the first 20–30 minutes of exposure to 0.3 ppm acrolein, after which a plateau was reached [17].

Rating of nasal irritation were low and statistically insignificant under all conditions of exposure except for 0.1 ppm acrolein in combination with EA. Nasal irritation has been reported by previously only at very high concentrations [17].

Ratings of smell increased immediately after the volunteers entered the chamber and more so upon exposure to EA than acrolein exposure, as expected, Lang and coworkers (2008) have proposed that the profound odor of EA influences rating of irritation, since, no significant effects were found upon co-exposure to 15 ppm EA [94]. Thus, sensory perception of irritation may be hindered by strong odor [95].

In our investigations, ratings of throat irritation, fatigue and other CNS symptoms were unaffected by exposure to acrolein and/or EA. The only gender differences observed were that women gave higher ratings after 60 minutes of exposure to 0.05 ppm acrolein, as well as the day after exposure to 0.1 ppm acrolein in combination with EA.

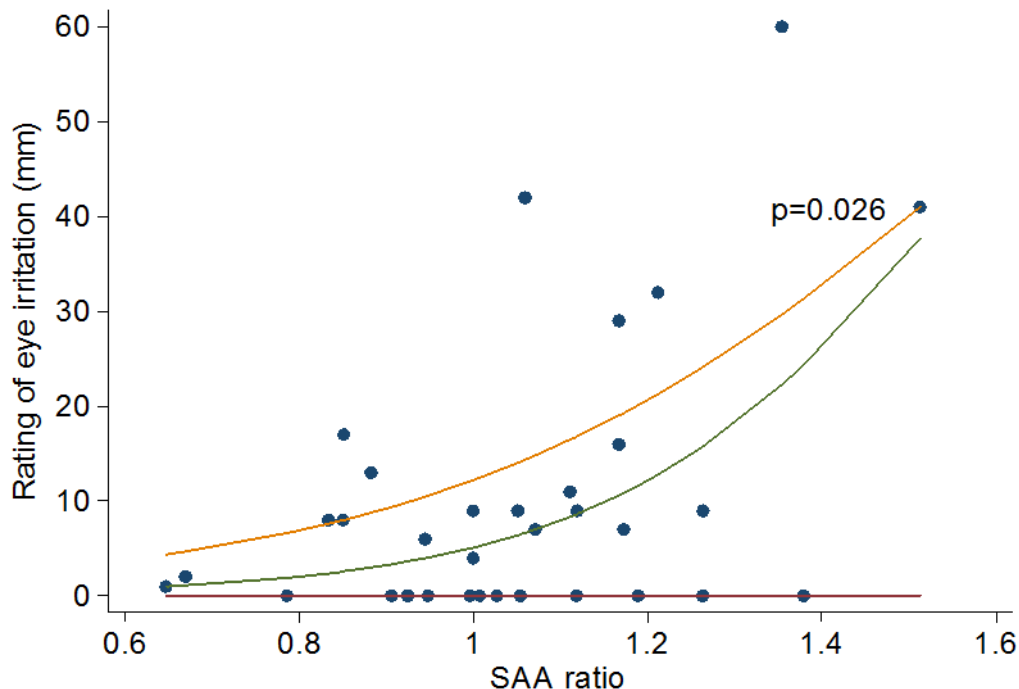

Figure 12: The relationship between rating of eye irritation and the serum amyloid A (SAA) ratio (after/before exposure). The dots represent individual ratings. The curves represent the

25th, 50th (median), and 75th percentile. Adapted from Paper I, with permission of the publisher.

The only significant correlation between any of the ratings and the levels of inflammatory markers in blood involved ratings of eye irritation and the SAA ratio (Figure 12). Analysis by logistic quantile regression revealed that the most sensitive subjects (i.e., those who rated highest) exhibited a significant association (75th percentile, $p = 0.026$) with a higher ratio of SAA following exposure to acrolein (Figure 12), perhaps due to up-regulation. Conklin and coworkers (2011) have also shown that acrolein up-regulates SAA in mice [96], which is a consequence of TRPA1 mediated inflammatory responses to environmental irritants such as acrolein and mustard gas [72]. The different subtypes of TRPA1 (3–4 haplotypes) [97] might thus help explain the variation in the ratings by our volunteers.

4.1.2.2 Effects on the eyes, airways, and nose

The frequency of blinking, as which was recorded by electromyography, was slightly higher during the final 20 minutes of exposure to 0.1 ppm acrolein compare than during to the first 20 minutes of exposure ($p = 0.049$, ANOVA), an effect not observed with any of the other conditions of exposure (Table 2, Paper 1). A significantly elevated blinking frequency during exposure to acrolein has also been reported by Weber-Tschopp and co-workers (1977), albeit at a higher level (0.26 ppm) [17]. Our volunteers were about 24 years old and young people are less sensitive to irritants than the elderly because of their more robust formation of a film tears. There were no exposure-related effects on the breathing frequency, pulmonary function and nasal parameters and no gender differences with the exception of higher FEV1/VC and FEV1/FVC ratios for women, irrespective of exposure, and higher VOL1 and MCA1 values for the men.

4.1.2.3 Markers of inflammation and coagulation in the blood and sputum

The levels of markers of inflammation and coagulation in the blood (IL-6, CRP, SAA, fibrinogen, factor VIII, vWF and CC-16) were not influenced by exposure to acrolein (IL-6 was tested only at 0 and 0.1 ppm) nor were the cell count, differential cell count, levels of IL-6 and IL-8 in the induced sputum (Supplement material to Paper I, Table 6). There were no gender differences with respect to any of the markers measured.

Previously the sputum of smokers has been shown to contain elevated number of inflammatory cells. Moreover, the level of IL-8, a chemoattractant for neutrophils, is increased in both the upper and lower airways of smokers [98]. The level of IL-6, a pro-

inflammatory cytokine is also enhanced in the airways in response to an inflammatory stimulus. Since acrolein is highly water soluble we could have chosen to measure these biomarkers in nasal lavage fluid or exhaled breath air condensate (EBC) instead.

In conclusion, this investigation demonstrated minor subjective eye irritation at short-term exposure to 0.1 ppm acrolein. These findings are inconsistent with those of Weber-Tschopp and colleagues (1977), who observed a significant increase in eye irritation at a level of 0.09 ppm [17].

4.2 THRESHOLDS FOR ODOR AND LATERALIZATION

There is considerable discrepancy concerning how to present odor and, consequently, a wide range of detection thresholds for odor and lateralization have been reported. Odors are either presented to subjects in amber bottles or employing expensive and technically challenging olfactometers.

4.2.1 Validation of our olfactometer

To deliver an accurate vapor concentration we developed a novel, yet simple olfactometer that responds rapidly and reliably to a shift in valve position (Figure 8). The findings upon exposure to vapors of acrolein, crotonaldehyde and hexanal confirmed that this olfactometer provides reliable values for thresholds for odor and lateralization. The air at the tip of the nose, 90% of the target concentration was attained within 15 seconds (Figure 8). The presentation timing which is dependent on the rate of air flow is less than 1 minute. This time can be shortened even more by accelerating the air flow, but this might drying out the respiratory lining, thereby triggering pain sensation and preventing precise measurements [99, 100].

Kobal and colleagues (1991) have also proposed that for odorous irritants, like aldehydes the interval between stimuli should be longer. The results of the amber bottle test here validate that our presentation method was reliable, i.e., the order of odor thresholds for all ten volunteers were the same order as with both procedures.[101].

4.2.2 Odor thresholds

The OT data for each volunteer are presented in Figure 13. The median OT for acrolein was 17 ppb, with range of 2.7–88.5 ppb (Figure 13). This median value is higher than the 3 ppb by Nagata (2003) [89] but lower than the 160 ppb found by Amoore and Haluta (1983) [101].

Unfortunately, only two of our 18 volunteers could smell acrolein even at the highest concentrations tested.

Eleven of 20 volunteers detected the odor of crotonaldehyde at the lowest concentration tested (i.e., 0.8 ppb) (Figure 13), whereas, two volunteers did not detect any odor even at the highest concentration (92.5 ppb). Thus our OT value for crotonaldehyde (0.8 ppb) was lower than the previously described values of 120 ppb by Amoore and Haluta (1983) [101] and 23 ppb by Nagata (2003) [89].

The median OT for hexanal was 97 ppb (11.7–3911 ppb) (Figure 13), which is higher than the previously published values of 25 ppb [73], and 11 ppb [102]. Again, two subjects could not detect any odor even at the highest concentration of hexanal tested. Nagata (2003) used trained subjects, whereas ours were naïve volunteers and we found considerable intra-individual variability in the ability to perceive odors [89].

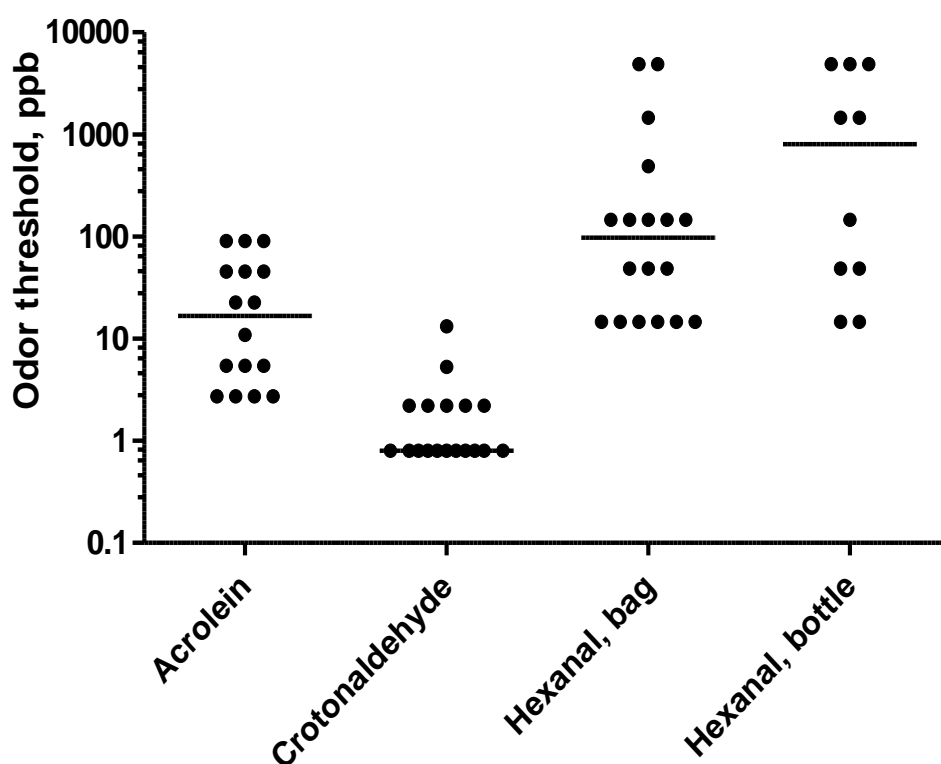

Figure 13: The odor thresholds for three aldehydes. Each dot represents the threshold in one individual. The horizontal lines represent medians. Adapted from Paper II, with permission from publisher.

4.2.3 Lateralization thresholds

The individual findings on LT are presented in Figure 14. Although we tested higher concentrations as high as 2940 ppb, LT for acrolein could be established only for one of the 20 volunteers, who had a value of 10.7 ppb. Published data regarding the irritation threshold for acrolein are scarce. In the previous described pilot study where 8 healthy volunteers were subjected to whole-body exposure to seven levels acrolein for 10 minutes up to 300 ppb, one subject rated marked nasal irritation at 40 ppb, while the other seven experienced little or no irritation at any level. Moreover, no nasal irritation was obtained in the main study with exposure at 0, 50 and 100 ppb for 2 hours. At the same time, there was large inter-individual variability in sensitivity to acrolein.

Several reports indicate irritation by acrolein is mediated by the TRPA1. For instance, TRPA1-deficient mice are insensitive to sensory irritation caused by acrolein and other electrophilic substances [77]. The underlying mechanism is presently being elucidated. Some scientists propose that acrolein covalently modifies the TRPA1 protein in a manner that opens the cation channel, thereby initiating neuronal depolarization and calcium ion influx into sensory nerve endings [103]. In our study, the combination of short exposure time with low concentrations of acrolein may explain why a LT was obtained for only one volunteer.

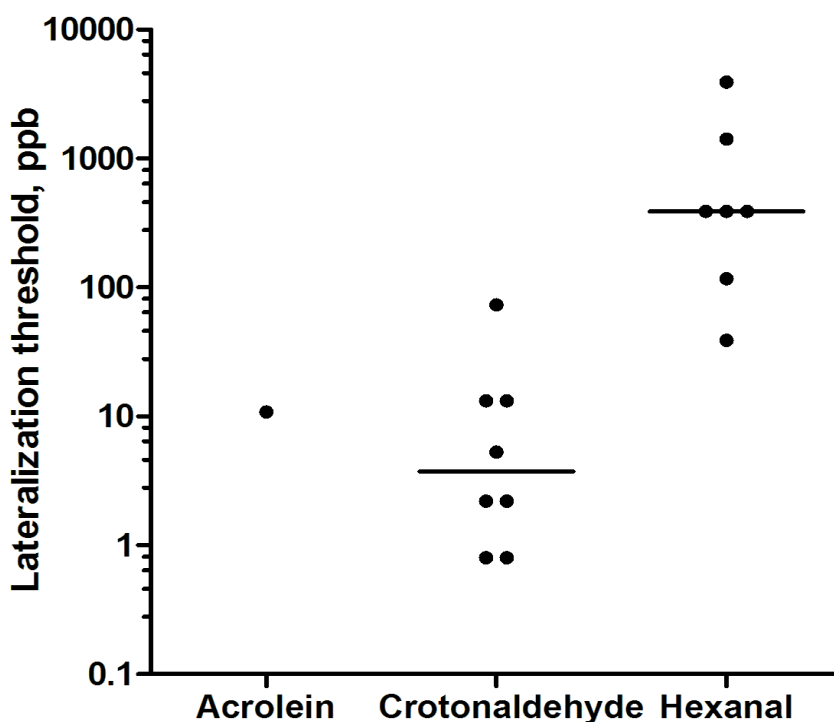

Figure 14: Lateralization threshold for three aldehydes. Each dot represents the threshold in one individual. The horizontal lines represent median. Adapted from Paper II, with permission.

The median LT for crotonaldehyde, observed in 8 volunteers was 3 ppb, a value much lower than the 170 ppb threshold for mucous membrane irritation of 170 ppb reported by Trofimov (1962) [104].

Hexanal LTs were reported by 6 of our 20 volunteers, with a median value of 390 ppb, which corresponds well with the LT of 281 ppb for sensory irritation (also based on ratings) reported by Li Zheng (2010) [73]. With our previous whole-body inhalation exposures to hexanal (0, 2000 and 10000 ppb for 2 hours), ratings of nasal irritation increased at 2000 ppb, starting at 60 minutes. Taking into consideration the differences in route of exposure (nose only versus whole body), exposure duration (5 seconds versus 2 hours) and endpoint measurement (categorical versus magnitude) between these two studies, the findings agree reasonably well. Therefore, we propose individual variation in trigeminal intranasal sensitivity is more pronounced for aldehydes than for other irritants.

4.3 EXPOSURE OF MICE TO ACROLEIN

Variation in individual susceptibility to acute lung injury induced by acrolein particularly at high levels is well known. The survival time of 40 inbred strains of mice differed more than two-folds after exposure to 10 ppm acrolein, BALB/cByJ mice (17 h) and 129X1/SvJ mice (>40h), strongly indicating a genetic predisposition [105]. In that investigation the inbred strains of mice selected for our study of response to sub-chronic exposure to acrolein (1 ppm) exhibited the following survival times: BALB/cByJ (17h); C57BL/6J (22h); 129S1/SvImJ (25h), DBA/2J (27h), C3H/HeJ (29h), A/J (30h), and FVB/NJ (33h).

4.3.1 Bronchoalveolar lavage

Total numbers of cells in BAL and protein content were not altered in any of the strains after exposure. These finding justify our use of low dose and sub-chronic exposure. Kashara and coworkers (2008), made similar observations, with no recruitment of inflammatory cells following exposure of C57BL/6J mice to sub-toxic concentrations of acrolein (5 ppm, 6 hours/day for up to 3 days), which were considered to be representative of indoor exposures [106].

4.3.2 Markers of inflammatory and oxidative stress markers

Several mediators play crucial roles in chronic inflammatory processes and apparently determining the nature of the response by the selectively recruiting and activating

inflammatory cells and regulating how long these cells remain within the lungs. Increased (2.5-3.5 fold) pulmonary levels of *Il17b* mRNA in the exposed BALB/cByJ, C57BL/6J and 129S1/Svm mice was detected in our study (Figure 15). These three strains employed the most sensitive to acute lung injury induced by acrolein by Leikauf and colleagues, 2011 [105]. IL-17b has been associated with enhanced recruitment of neutrophils in mice models of asthma [107]. Although, we could not detect any change in total cell number in BAL fluid, the elevated levels of *Il17b* mRNA may be associated with susceptibility to lung damage by acrolein.

Oxidative stress, including exposure to products of lipid peroxidation and/or depletion of reduced glutathione, causes rapid ubiquitination and phosphorylation with subsequent degradation of the I κ B complex, a critical step of *Nfkb1* activation. Brennan and colleagues (1995) found that oxidative stress promotes the activation and translocation of *Nfkb1* to the nucleus, although, activation of *Nfkb1* in association with oxidative stress is highly cell specific [108]. The elevation in pulmonary levels of mRNA encoding *Nfkb1*, as well as *Sod3*, *Gpx1* and 3 in the mice to exposed acrolein strongly supports the presence of oxidative stress. Several investigations both *in vivo* and *in vitro* have also demonstrated that both reactive oxygen species and *Tnfa* promote activation of *Nfkb1* as well as of *Il6* and *Cxcl2/Mip2* [109-111].

The elevated pulmonary levels of *Nfkb1* lung transcripts in BALB/cByJ, C57BL/6J and 129S1/SvImJ mice exposed to acrolein may result in a substantial pro-inflammatory reaction. *Nfkb1* signaling is a key determinant of airway hyper-responsiveness to inhaled agents [112]. Indeed, activation of the *Nfkb1* pathway is sufficient to induce acute lung injury and also exerts considerable impact on other central biological processes, including host defenses [113].

Of the numerous reports on the regulation of inflammatory responses to environmental stress via the *Nfkb1* pathway, several have focused on immune cells. However, Cheng and co-workers (2007) demonstrated that *Nfkb1* signaling in non-immune cells is also a critical determinant of pulmonary responses to harmful stimuli. Human studies also support the role of *Nfkb1* dependent mediators in inducing lung injury, although the cell that generate these mediators are not yet well defined. Many researchers [112, 113], have reported that activation of *Nfkb1* in airway epithelial cells of mice enhances expression of several cytokines and chemokines including *IL6*, granulocyte colony stimulating factor (*G-csf*), granulocyte macrophage colony stimulating factor (*Gm-csf*), *Cxcl2/Mip-2*, *Cxcl1* (aka keratinocyte-derived chemokine/Kc), *Il17* etc.

The findings described above are comparable with our present observation that sub-chronic exposure to acrolein results in induction of *Nfkb1* as well as *Nfkb* dependent mediators (*Il6*, *Cxcl1*) that may be involved in causing lung injury in susceptible mice strains over time (Figure 15).

4.3.3 Markers of tissue injury/repair

Activation of *Mmp9*, the predominant matrix metalloproteinase of the airway epithelium, can be promoted by acrolein, at concentration similar to those present in the sputum of patients with chronic bronchitis patients [114]. An imbalance of anti-proteinases and proteinases, in particular *Mmps* and *Timps*, is an important aspect of the pathogenesis of chronic lung diseases [114, 115]. Expression of *Mmp9* is also regulated by numerous stimulatory factors, including several pro-inflammatory cytokines and endogenous inhibitors, such as *Timps* [116-118]. Unaltered *Timp1* and 2 appear to be involved in the activation of *Mmp9* mediated overproduction of mucus [114]. Therefore, our current finding that acrolein elevates the level of *Mmp9* and unaltered *Timp1* transcript expression in mice is indicative of susceptibility. On the basis of the scoring matrix discussed above, involving oxidative stress, along with markers of inflammation and tissue injury, we propose that the susceptibility of the mice strains tested (in descending order) to pulmonary toxicity as a consequence of sub-chronic exposure to acrolein is as follows: C57BL/6J, 129S1/SvImJ, BALB/cByJ, C3H/HeJ, A/J, DBA/2J and FVB/NJ.

In conclusion, in seven inbred strains of mice commonly used in respiratory research sub-chronic exposure to a low dose (1 ppm) of acrolein does not lead to acute lung injury. Nevertheless, several significant and selective changes in the levels of markers of oxidative stress, pro-inflammation and tissue injury can apparently discriminate between sensitive and resistant strains. This finding provide further evidence that acrolein is involved in the impairment of innate immune responses that may predispose to chronic lung diseases. Clearly, chronic exposure studies with these mice strains might help to unravel the mechanisms underlying acrolein-mediated lung toxicity.

Filter air (Control)
 1 ppm acrolein

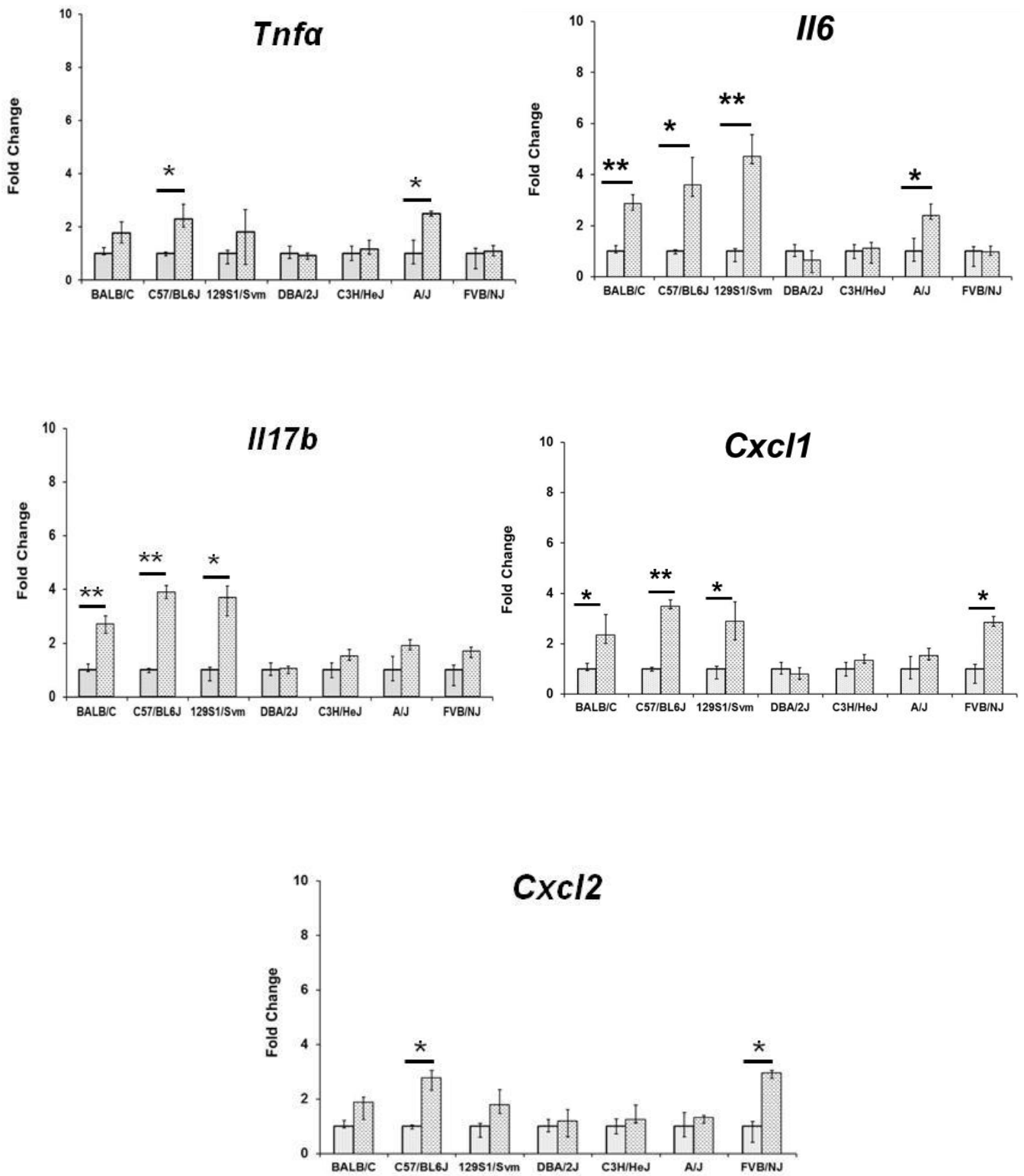

Figure 15: Lung transcript analysis of pro-inflammatory markers in seven mouse strains exposed to filter air or acrolein (1 ppm, 6 hours/day and 4-5 days/week for 11 weeks)

4.4 EXPOSURE OF THE AIRWAY MUCOSA MODEL

Here, we examined the inflammatory responses and cytotoxicity of aldehydes employing the airway mucosa model and under submerged conditions. In addition, we established that exposure to α , β -unsaturated aldehydes enhance oxidative stress and inflammation as indicated by changes at both protein and mRNA levels in PBEC-ALI. In contrast, submerged exposures to acrolein and crotonaldehyde significantly reduce the IL-8 secretion along with the expression of *IL8* and *NFKB*. The effects of hexanal were less pronounced effects but there was still elevated secretion of IL-8 upon exposure at ALI and increased expression of *TNFA* under submerged conditions.

4.4.1 Cell viability

Cell viability (as assessed by exclusion of trypan blue) was reduced only at the two highest concentrations of acrolein and crotonaldehyde tested. These α , β -unsaturated aldehydes bind to glutathione, cause oxidative stress and may lead to cell death via either apoptosis or necrosis. Others have also reported that at high doses both acrolein and crotonaldehyde decrease the viability of primary cells or cell lines [119, 120]. No change in viability was observed at any concentration of hexanal, which is known to be less potent than these two other aldehydes.

4.4.2 Changes in the levels of IL-8 and MMP-9

4.4.2.1 PBEC-ALI model

With this model release of IL-8 in the basal medium was unaltered following 8 or 24 hours after exposure to acrolein, with crotonaldehyde the dose-effect relationship was inverted U-shaped with highest levels of IL-8 in the basal medium after exposure to the two intermediate concentrations, both at 8 (1 and 2 ppm) and 24 hours (1 and 2 ppm). In comparison to clean air exposure, the level of this cytokine was significantly elevated following 8 hours of exposure to hexanal at all concentrations tested. In the apical medium release of IL-8 was attenuated after exposure to 0.2 ppm acrolein at 24 hours and 1 ppm crotonaldehyde at 8 hours.

It is well established that aldehydes cause inflammation and promote the generation of reactive oxygen species both *in vivo* and *in vitro* [20, 121-124] including on higher doses, under submerged conditions and in cell lines [124-127]. However, little quantitative information concerning gaseous exposure at an ALI is presently available. The basal/apical

release of IL-8 by the PBEC-ALI model observed here was in agreement with the findings by Mio and colleagues (1997), who found that acrolein elevates IL-8 release in human bronchial epithelial cells in a concentration-dependent manner, with a peak response at 10 μ M (0.56 mg/L) acrolein in the medium [126].

Here, exposure of PBEC-submerged to 0.1 and 0.2 mg/L acrolein significantly attenuated secretion of IL-8 and MMP-9 at both concentrations and time points (6 and 24 hours), while crotonaldehyde reduced the level of IL-8 following 6 (1 mg/L) and at 24 hours (2 mg/L) of exposure, as compared to sham. The level of MMP-9 was not affected by crotonaldehyde or hexanal under the submerged conditions. The present findings are consistent with previous indications that acrolein and crotonaldehyde can act either in an immunosuppressive [124, 125] or pro-inflammatory manner depending on the cell type and concentrations [27, 122, 123, 128]. We found lowered levels of both IL-8/*IL8* mRNA and protein after submerged exposure to acrolein. The inflammatory response is characterized by coordinate activation of various signaling pathways that regulates expression of both pro- and anti-inflammatory mediators.

The level of MMP-9 in apical medium was significantly increased after 8 and 24 hours to exposure to 2 and 5 ppm of crotonaldehyde, 20 and 50 ppm hexanal, respectively. Furthermore, this level was higher in the apical than the basal medium following 8 and 24 hours of exposure to all concentrations of acrolein, hexanal and crotonaldehyde tested (with the exception of 5 ppm crotonaldehyde), despite the difference in collection time (15 minutes apical medium vs 8 hours/24 hours basal medium).

MMP-9 is a type IV collagenase involved in remodeling and aldehydes may promote its epithelial secretion by causing damage that requires remodeling of extracellular matrix (ECM), probably to achieve rapid re-epithelialization [116]. Atkinson and colleagues (2003) also attributed a substantial modulating effect on other enzymes and cytokines to MMP-9. Therefore, the significant rise in apical levels of MMP-9 in our ALI models could reflect a first line of defense that triggers and potentiates subsequent cascades, including recruitment and stimulation of the innate immune system [116]. In this context, MMP-9 is known to evoke a ten-fold increase in the IL-8 induced chemotaxis of neutrophils [129].

4.4.3 Changes in m-RNA levels

The levels of mRNA encoding *HMOX1*, a marker of oxidative stress and *TNFA*, an inflammatory marker were significantly upregulated after 6 hours exposure to 0.1 and 0.2

ppm acrolein. Exposure to 2 ppm crotonaldehyde elevated the levels of *HMOX1*, *TNFA* and *NFKB* mRNA, while the levels of *MMP9* mRNA were significantly increased by exposure to 1 ppm crotonaldehyde after 6 hours.

Human bronchial epithelial cells was exposed to 5–20 μ M (0.3–1.1 mg/L) acrolein for 12 hours under submerged conditions have been reported to have significantly elevated levels of *HMOX1* mRNA [130]. In contrast, to our exposure of submerged PBECs to 0.1 mg/L acrolein resulted in significant down-regulation of *HMOX1*. Previously, exposure of submerged human adenocarcinoma lung cells (A549) to 100 μ M acrolein (5.6 mg/L) for 1 hour was found to down-regulate 478 genes and up-regulate of 139 others, including *HMOX1* [131]. These discrepancies in the *HMOX1* response may reflect the use of different dose (50 fold higher concentration), cell types (primary cells versus cell lines), and duration of exposure, as well as post exposure incubation. Moghe and co-workers have also proposed that the levels of exposure (acrolein) can explain much of such discrepancies between different studies [27].

We observed significant down-regulation of *NFKB* along with an elevated of *HMOX1* mRNA following submerged exposure to 1 mg/L crotonaldehyde, which agrees with findings by Liu and colleagues (2010) at higher levels exposure (40 μ M, (2.8 mg/L)) [51]. Moreover, Liu and colleagues, 2010 [50] also observed up-regulation of *HMOX1*. As confirmed by sequencing of the human *HMOX1* promoter, *HMOX1* induction involves of multiple signaling cascades regulated by oxidants and electrophiles (such as acrolein and crotonaldehyde), which supports our findings of up-regulation of *HMOX1* after exposure at ALI.

However, we found that 20 mg/L hexanal significantly up-regulated *TNFA*, a key mediator of inflammatory responses under submerged conditions. TNF-A is a key molecule which is responsible for of the inflammatory change. Although, not well studied as an aldehyde hexanal may cause oxidative stress and affect a variety of biological processes. In support of this suggestion, transcriptome analysis of human alveolar cells (A549) exposed to hexanal revealed changes in gene expression associated specifically with pulmonary effects [66, 132].

To summarize, the responses of the airway mucosa model to aldehydes are similar to *in vivo* responses, whereas, responses under submerged conditions are not. Thus our novel PBEC-ALI system with exposure *via* air provides a useful model for studying the inflammatory and other adverse effects of inhaled agents.

5 CONCLUDING REMARKS

We have performed exposure studies with different experimental models which ranges from human subjects to animal models and to advanced cell models based on primary human cells. The aim of this thesis was to characterize irritation and inflammation caused by exposure to aldehydes, with the main focus on acrolein. Our human exposure study showed, that the most prominent effect was eye irritation, but there was tendency towards throat irritation and as well as a positive association between ratings of eye irritations and the level of SAA in blood suggesting up-regulation of this marker in the most sensitive subjects only. The threshold of irritation by the aldehydes tested was low. In mice exposure to acrolein exert the most pronounced impact on the most sensitive strains, up-regulating the markers of pro-inflammation and oxidative stress in the three most sensitive strains. Furthermore, exposure of the airway mucosa model to acrolein and crotonaldehyde vapors cultured at an air-liquid interface resulted in up-regulation of inflammatory markers, in line with *in vivo* findings. These effects were limited, probably because the exposure levels were low and comparable to realistic exposure in the indoor and outdoor environments. Altogether, our findings indicate that low levels of vapors of aldehydes may cause irritation and inflammation, at least in the more susceptible individuals.

6 FUTURE PERSPECTIVES

Acrolein may exert toxic effects on the entire respiratory tract, from the nasal epithelium to the alveolar spaces. Development of an airway mucosa model including nasal epithelium and alveolar sacs by further refinement of our model would be of considerable value. This research strategy might involve developing a lung-on-a-chip or whole body-on-a-chip with tools that could be coupled to realistic delivery of puffs of cigarette smoke.

Although acrolein has been thoroughly studied, individual differences in susceptibility to its acute pulmonary toxicity still need to be explored. Crotonaldehyde has effects similar to those of acrolein, but is less well studied and investigation on primary cells could provide deeper insight into its toxic effects. Hexanal is the least well-characterized of the three tested aldehydes and requires more focus.

Increasing incidences of chronic lung diseases such as asthma and COPD have been closely linked to rising air pollution in cities worldwide. As ubiquitous presence of aldehyde pollutants and potent airway irritants (acrolein, crotonaldehyde and hexanal) are all of interest and may indeed have synergistic interactions that could be looked with our airway mucosa model. Since these aldehydes may have synergies, their combinatory toxicity might be higher than the one observed individually.

Our novel olfactometer allows better control of timing of presentation and vapor concentration and there was a tendency towards lower OT and LT values. However, we could not determine any irritation threshold for acrolein. Additional evaluation of the reliability and validity of this olfactometer is required.

7 ACKNOWLEDGMENTS

This thesis could not have been possible without the participation and support of many people, whom I would like to thank now.

First and foremost, I would like to express my sincere gratitude to **Dr. Lena Ernstgård** for being my main supervisor. Many thanks for giving me the opportunity to pursue my PhD, working with you and for staying beside me whenever I needed. I have enjoyed all aspects of our research and discussions together.

I am highly indebted to my co-supervisor **Prof. Gunnar Johanson** for introducing me to the field of work environment toxicology and for helping me to improve my writing. I have learnt a lot during these years and would be happy to learn more from you.

I have also very much appreciated working with my co-supervisor **Dr. Lena Palmberg**, who has also taught me many new techniques. I cherish your very positive attitude towards research and life.

It has been a pleasure to discuss research problems with my co-supervisor **Dr. Johnny C Lorentzen** I would like to thank you for sharing your knowledge.

I also want to thank my mentor **Dr. Ann-Sophie Merrit**, who was always present whenever I needed her.

I am grateful to all the volunteers. Their participation made these studies possible.

I also thank all the co-authors and persons who help me in the laboratory and while writing papers/manuscripts, Prof. Terry Gorden and his colleagues, Dr. Britt-Marie Sundblad, Lena Possne, Dr. Swapna Upadhyay, Dr. Bengt Sjögren for your enthusiasm about research.

I would also like to thank Ann-Katrin Sjöden for helping with nice illustrations.

I would express my deepest gratitude to Prof. KVS Hari for bringing us to Stockholm and to Prof. Peter Händel for your support.

Prof. Joe D Pierre for his valuable editing of this thesis.

I would also like to thank both my present and past office room-mates for encouraging me during these years; Dr. Kristin Stamy, Dr. Stephanie Anja Juran, Kristin Larsson, Cecillia Wallin, Ophélie Brn, Tania Thimraj, Achilleas Pexaras and other master students. With a special thanks to, Tshepo Moto and Estella Garessus for our lunch outings to Indian Street

Food, discussions and my thesis reading. Among my many fellow colleagues, I would like to express gratitude to Dr. Joakim Ringblom for all the IMM parties and discussions, Dr. Mia Johansson, Dr. Ulrika Carlander and Dr. Linda Schenk for your positive attitude, lunch walks and fun activities during SOT. It was a pleasure to have you all around, Dr. Emma Wincent, Dr. Carolina Vogs, Dr. Mattias Öberg, Dr. Elin Törnqvist, Dr. Afshin M. Bardbori, Dr. Johanna Bengtsson and Dr. Linda Bergander. Thanks to Dr. Koustav Ganguly for creating a stress-free environment. It was nice to have many nice people in the same corridor Prof Agneta Rannug, Brigit Postol, Annika Calgeborn, Lina Graner, Dr. Anders Iregren, Dr. Marie Nyman, Dr. Johan Montellius, Dr. Anna Karin Mörk, Dr. Anna Karin Alexandrie, Birgitta Lindell, Dr. Jill Järnberg, Dr. Matias Rauma, Dr. Martin Fransson, Dr. Tao Liu, Dr. Mark André, Siraz Shaik and Dr. Jenny.

Thanks to the airway research group for being amazing colleagues both at work tox and at Retzius, Jie Ji, Anna hedlin, Dr. Bettina Levänen, Dr. Karlhans Che for all the fun moments in the laboratory and working together on the airway mucosa model. I would also like to thank Dr. Anneli Julander, Jolinde Kettelarij, Dr. Klara Midander, Prof. Carola Lidén, Christine S Anto, Dr. Sandra Gracia, Dr. Maria Lagrelius, Dr. Melissa Kovach and Prof. Anders Lindén, Mizanur Rahman, Divya Thiagarajan, Auriba Raza and all the colleagues at IMM for all your positivity and help during these years.

Last but not the least, I wish to thank all my friends for being there in good and bad times. Maneesh, Deepika, Pooja, Pradeep, Ritu, Pankaj, Vibhor, Vidhu, Rakesh, Rajni, Nonah, Sunil, Nibha, Rahul, Dr. Hansa and Dr. Jayant, Seema, Asim, Dr. Apurba, Anurupa, Rajat, Divya, Avneesh, Deepa, Dr. Dave, Dr. Preethi, Dr. Saikat, Sutapa, Arun, Hans, Ann-sofi, Anders, Dr. Sanjeev, Sharda, Dr. Rahul and Dr. Rohit for all your positivity and expected / unexpected weekend plans. Thank also to my friend Dr. Akanksha for all our fun trips and fun during these years. All the amazing kids around always gave me reasons to smile, Anirudh, Annika, Adi, Uday, Archisman, Arnav, Tanishka, Kashvi, Ravya, Choti Annika, Krishna, Harsh, Risha, Ritam, Ishan, Aditi, Ayra, Riyona, Ishana, Srishti and Swati.

I would like thank all my friends and mentors from CDRI (Dr. Bechan Sharma, Dr. AK Balapure, Dr. Ramesh, Dr. RK Singh, Dr. SK Rath and Dr Sharad) and Advinus (Dr. Rajesh, Dr. Santhosh, Pradeep, Raghu, Suman, Rangnath, Yuvraj, Mohan babu, Ganesha, Dr. Bhoite, Dr. KS Rao, Dr. RS Rao, Dr. Ravi K and Ravi C) for your support. I cannot finish without thanking my old friends Vindu, Pooja, Shiwani, Jasmeet, Nitu, Prashant and Abdul for your

friendship. I know that no matter how far apart we are, you will always be there if I need you.

I would like to thank some friends who are family to me: DS Tiwari, Rajesh, US Tiwari, Dr. KP Dwivedi, Rajendra Dwivedi, Aunties (Usha, Rajeshwari, Asha) and Shweta.

Finally, I wish to express my gratitude to my parents, grand-parents, in-laws, brothers (Rishi, Anadi, Shivam), sister in-laws (Veena, Saundram, Kaushiki, Shikha and Lili), brother in-laws Sanjeev and Sujit, my nephews (Manas, Gannu, Ayush, Suyash and Shreyas) and nieces (Anusha, Areyehi and Aru), uncles (Mithilesh, Satyasheel, RS Mishra, HS Mishra, RS Mishra II, Arvind, Devendra, GS Mishra, Vipin and Suresh) and aunties (Anamma, Krishna, Usha, Madhurima, Bharti, Manju, Gayatri, Javitri, Arti and Rama). Thanks to all cousins Yogesh, Renu, Meenu, Bhawana, Abhijeet, Akanksha, Ruby, Ankit, Sudipti, Aditi, Supriya, Achut, Mridual, Shrish, Alok, Juhi, Vaibhav, Ananya, Garima, Ansh and all the other family members for your endless encouragement support.

My special thanks to my husband Dr. Satyam for your patience, love, care and support during these years. I love you!

This list could become much longer, but let me just say that, I am grateful to each and every one of you who has supported me during these years and before.

8 REFERENCES

1. O'Brien, P.J., A.G. Siraki, and N. Shangari, *Aldehyde sources, metabolism, molecular toxicity mechanisms, and possible effects on human health*. Crit Rev Toxicol, 2005. **35**(7): p. 609-62.
2. LoPachin, R.M. and T. Gavin, *Molecular mechanisms of aldehyde toxicity: a chemical perspective*. Chemical Research in Toxicology, 2014. **27**(7): p. 1081-91.
3. Beauchamp, R.O., et al., *A Critical-Review of the Literature on Acrolein Toxicity*. Crc Critical Reviews in Toxicology, 1985. **14**(4): p. 309-380.
4. Ghilarducci, D.P. and R.S. Tjeerdema, *Fate and effects of acrolein*. Rev Environ Contam Toxicol, 1995. **144**: p. 95-146.
5. Logue, J.M., et al., *Spatial variation in ambient air toxics concentrations and health risks between industrial-influenced, urban, and rural sites*. J Air Waste Manag Assoc, 2010. **60**(3): p. 271-86.
6. Bein, K. and G.D. Leikauf, *Acrolein - a pulmonary hazard*. Mol Nutr Food Res, 2011. **55**(9): p. 1342-60.
7. Faroon, O., et al., *Acrolein health effects*. Toxicol Ind Health, 2008. **24**(7): p. 447-90.
8. Environment Protection Agency, U.S.E.P.A., *Acrolein*. 2015.
9. Golden, R. and S. Holm, *Indoor Air Quality and Asthma: Has Unrecognized Exposure to Acrolein Confounded Results of Previous Studies? Dose-Response*, 2017. **15**(1).
10. Bentayeb, M., et al., *Indoor air quality, ventilation and respiratory health in elderly residents Living in nursing homes in Europe*. European Respiratory Journal, 2015. **45**(5): p. 1228-1238.
11. MAK Commission, *Acrolein*. 2006.
12. American Conference of Governmental Industrial Hygienists, ACGIH, *ACROLEIN*. 1992.
13. Svendsen, K., et al., *Exposure to cooking fumes in restaurant kitchens in Norway*. Ann Occup Hyg, 2002. **46**(4): p. 395-400.
14. Vainiotalo, S. and K. Matveinen, *Cooking Fumes as a Hygienic Problem in the Food and Catering Industries*. American Industrial Hygiene Association Journal, 1993. **54**(7): p. 376-382.
15. Faroon, O., et al., *Acrolein environmental levels and potential for human exposure*. Toxicol Ind Health, 2008. **24**(8): p. 543-64.
16. Bengtsson L and A. A-B, *Brandmännens arbetsmiljö. Kemiska hälsorisker och förslag till åtgärder. IVL rapport. Räddningsverket 1993; R49-101/93*. 1993.
17. Weber-Tschopp, A., et al., *[Experimentally induced irritating effects of acrolein on men (author's transl)]*. Int Arch Occup Environ Health, 1977. **40**(2): p. 117-30.
18. Azuma, K., I. Uchiyama, and K. Ikeda, *The risk screening for indoor air pollution chemicals in Japan*. Risk Anal, 2007. **27**(6): p. 1623-38.

19. Hecht, S.S., et al., *Elevated levels of mercapturic acids of acrolein and crotonaldehyde in the urine of Chinese women in Singapore who regularly cook at home*. Plos One, 2015. **10**(3): p. e0120023.
20. Kehrer, J.P. and S.S. Biswal, *The molecular effects of acrolein*. Toxicological Sciences, 2000. **57**(1): p. 6-15.
21. Tanel, A. and D.A. Averill-Bates, *The aldehyde acrolein induces apoptosis via activation of the mitochondrial pathway*. Biochim Biophys Acta, 2005. **1743**(3): p. 255-67.
22. Tanel, A. and D.A. Averill-Bates, *Activation of the death receptor pathway of apoptosis by the aldehyde acrolein*. Free Radic Biol Med, 2007. **42**(6): p. 798-810.
23. Li, L., et al., *Acrolein-induced cell death in human alveolar macrophages*. Toxicol Appl Pharmacol, 1997. **145**(2): p. 331-9.
24. Uchida, K., *Current status of acrolein as a lipid peroxidation product*. Trends Cardiovasc Med, 1999. **9**(5): p. 109-13.
25. Jia, L., et al., *Acrolein, a toxicant in cigarette smoke, causes oxidative damage and mitochondrial dysfunction in RPE cells: protection by (R)-alpha-lipoic acid*. Invest Ophthalmol Vis Sci, 2007. **48**(1): p. 339-48.
26. Uchida, K., et al., *Protein-bound acrolein: potential markers for oxidative stress*. Proc Natl Acad Sci U S A, 1998. **95**(9): p. 4882-7.
27. Moghe, A., et al., *Molecular Mechanisms of Acrolein Toxicity: Relevance to Human Disease*. Toxicological Sciences, 2015. **143**(2): p. 242-255.
28. Yeager, R.P., et al., *Proposed Mode of Action for Acrolein Respiratory Toxicity Associated with Inhaled Tobacco Smoke*. Toxicological Sciences, 2016. **151**(2): p. 347-64.
29. Zarkovic, N., et al., *Pathophysiological relevance of aldehydic protein modifications*. J Proteomics, 2013. **92**: p. 239-47.
30. Pizzimenti, S., et al., *Interaction of aldehydes derived from lipid peroxidation and membrane proteins*. Front Physiol, 2013. **4**: p. 242.
31. Kawai, Y., et al., *Formation of acrolein-derived 2'-deoxyadenosine adduct in an iron-induced carcinogenesis model*. J Biol Chem, 2003. **278**(50): p. 50346-54.
32. Chung, F.L., R. Young, and S.S. Hecht, *Formation of cyclic 1,N2-propanodeoxyguanosine adducts in DNA upon reaction with acrolein or crotonaldehyde*. Cancer Res, 1984. **44**(3): p. 990-5.
33. Minetti, C.A., et al., *Impact of alpha-hydroxy-propanodeoxyguanine adducts on DNA duplex energetics: opposite base modulation and implications for mutagenicity and genotoxicity*. Biopolymers, 2010. **93**(4): p. 370-82.
34. Tang, M.S., et al., *Acrolein induced DNA damage, mutagenicity and effect on DNA repair*. Mol Nutr Food Res, 2011. **55**(9): p. 1291-300.
35. Kozekov, I.D., et al., *DNA interchain cross-links formed by acrolein and crotonaldehyde*. J Am Chem Soc, 2003. **125**(1): p. 50-61.
36. Burcham, P.C., et al., *Intermolecular protein cross-linking during acrolein toxicity: efficacy of carbonyl scavengers as inhibitors of heat shock protein-90 cross-linking in A549 cells*. Chemical Research in Toxicology, 2007. **20**(11): p. 1629-37.

37. Czerny, C., E. Eder, and T.M. Runger, *Genotoxicity and mutagenicity of the alpha, beta-unsaturated carbonyl compound crotonaldehyde (butenal) on a plasmid shuttle vector*. *Mutat Res*, 1998. **407**(2): p. 125-34.
38. Kuwata, K., M. Uebori, and Y. Yamasaki, *Determination of Aliphatic and Aromatic-Aldehydes in Polluted Airs as Their 2,4-Dinitrophenylhydrazones by High-Performance Liquid-Chromatography*. *Journal of Chromatographic Science*, 1979. **17**(5): p. 264-268.
39. IARC, *Crotonaldehyde IARC Monographs on the Evaluation of Carcinogenic Risks to Humans, International Agency for Research on Cancer (1995) pp. 373–391*. 1995.
40. Lipari, F. and S.J. Swarin, *Determination of Formaldehyde and Other Aldehydes in Automobile Exhaust with an Improved 2,4-Dinitrophenylhydrazine Method*. *Journal of Chromatography*, 1982. **247**(2): p. 297-306.
41. Coenraads, P.J., E. Bleumink, and J.P. Nater, *Susceptibility to primary irritants: age dependence and relation to contact allergic reactions*. *Contact Dermatitis*, 1975. **1**(6): p. 377-81.
42. Steinhagen, W.H. and C.S. Barrow, *Sensory irritation structure-activity study of inhaled aldehydes in B6C3F1 and Swiss-Webster mice*. *Toxicol Appl Pharmacol*, 1984. **72**(3): p. 495-503.
43. Babiuk, C., W.H. Steinhagen, and C.S. Barrow, *Sensory irritation response to inhaled aldehydes after formaldehyde pretreatment*. *Toxicol Appl Pharmacol*, 1985. **79**(1): p. 143-9.
44. Chung, F.L., T. Tanaka, and S.S. Hecht, *Induction of liver tumors in F344 rats by crotonaldehyde*. *Cancer Res*, 1986. **46**(3): p. 1285-9.
45. Wang, M.Y., F.L. Chung, and S.S. Hecht, *Identification of crotonaldehyde as a hepatic microsomal metabolite formed by alpha-hydroxylation of the carcinogen N-nitrosopyrrolidine*. *Chemical Research in Toxicology*, 1988. **1**(1): p. 28-31.
46. Minko, I.G., et al., *Chemistry and biology of DNA containing 1,N(2)-deoxyguanosine adducts of the alpha,beta-unsaturated aldehydes acrolein, crotonaldehyde, and 4-hydroxynonenal*. *Chemical Research in Toxicology*, 2009. **22**(5): p. 759-78.
47. Ichihashi, K., et al., *Endogenous formation of protein adducts with carcinogenic aldehydes: implications for oxidative stress*. *J Biol Chem*, 2001. **276**(26): p. 23903-13.
48. Lambert, C., et al., *Acrolein inhibits cytokine gene expression by alkylating cysteine and arginine residues in the NF-kappaB1 DNA binding domain*. *J Biol Chem*, 2007. **282**(27): p. 19666-75.
49. Lambert, C., et al., *Acrolein in cigarette smoke inhibits T-cell responses*. *J Allergy Clin Immunol*, 2005. **116**(4): p. 916-22.
50. Liu, X.Y., et al., *Crotonaldehyde induces oxidative stress and caspase-dependent apoptosis in human bronchial epithelial cells*. *Toxicol Lett*, 2010. **195**(1): p. 90-8.
51. Liu, X.Y., et al., *Gene expression profile and cytotoxicity of human bronchial epithelial cells exposed to crotonaldehyde*. *Toxicol Lett*, 2010. **197**(2): p. 113-22.
52. Yang, B.C., et al., *Crotonaldehyde induces apoptosis in alveolar macrophages through intracellular calcium, mitochondria and p53 signaling pathways*. *J Toxicol Sci*, 2013. **38**(2): p. 225-35.

53. Yang, B.C., et al., *Crotonaldehyde induces apoptosis and immunosuppression in alveolar macrophages*. *Toxicol In Vitro*, 2013. **27**(1): p. 128-37.
54. Lee, S.E., et al., *Induction of heme oxygenase-1 inhibits cell death in crotonaldehyde-stimulated HepG2 cells via the PKC-delta-p38-Nrf2 pathway*. *Plos One*, 2012. **7**(7): p. e41676.
55. Ryu, D.S., et al., *Crotonaldehyde induces heat shock protein 72 expression that mediates anti-apoptotic effects in human endothelial cells*. *Toxicol Lett*, 2013. **223**(2): p. 116-23.
56. HMDB. *Hexanal* 2011; Human Metabolome Database]. Available from: <http://www.hmdb.ca/metabolites/HMDB0005994>.
57. Villanueva, F., et al., *Levels and sources of volatile organic compounds including carbonyls in indoor air of homes of Puertollano, the most industrialized city in central Iberian Peninsula. Estimation of health risk*. *Int J Hyg Environ Health*, 2015. **218**(6): p. 522-34.
58. Ernstgard, L., et al., *Acute effects of exposure to hexanal vapors in humans*. *J Occup Environ Med*, 2006. **48**(6): p. 573-80.
59. Chavez-Servin, J.L., A.I. Castellote, and M.C. Lopez-Sabater, *Volatile compounds and fatty acid profiles in commercial milk-based infant formulae by static headspace gas chromatography: Evolution after opening the packet*. *Food Chemistry*, 2008. **107**(1): p. 558-569.
60. Chow, P.Y., et al., *Evaluation of ten potential organic spermicides*. *Int J Fertil*, 1980. **25**(4): p. 281-6.
61. De Haan, L.H., et al., *Effect of lipids and aldehydes on gap-junctional intercellular communication between human smooth muscle cells*. *Carcinogenesis*, 1994. **15**(2): p. 253-6.
62. Bingham, E.C., B; Powell, C.H, *Patty's Toxicology Volume 1-9 5th edition*. 2001.
63. Hamaguchi-Hamada, K., et al., *Exposure to hexanal odor influences maternal behavior and induces neonatal death in Fyn tyrosine kinase-deficient mice*. *Neurosci Res*, 2004. **48**(3): p. 259-67.
64. Brambilla, G., et al., *Mutagenicity in V79 Chinese hamster cells of n-alkanals produced by lipid peroxidation*. *Mutagenesis*, 1989. **4**(4): p. 277-9.
65. Cho, Y., et al., *Toxicogenomic analysis of the pulmonary toxic effects of hexanal in F344 rat*. *Environ Toxicol*, 2017. **32**(2): p. 382-396.
66. Cho, Y., et al., *Analysis of Dose-Response to Hexanal-Induced Gene Expression in A549 Human Alveolar Cells*. *Biochip Journal*, 2014. **8**(2): p. 75-82.
67. Ernstgard, L., et al., *Acute effects of exposure to vapours of acetic acid in humans*. *Toxicol Lett*, 2006. **165**(1): p. 22-30.
68. Ernstgard, L., et al., *Acute effects of exposure to vapours of dioxane in humans*. *Hum Exp Toxicol*, 2006. **25**(12): p. 723-9.
69. Ernstgard, L., et al., *Acute effects of exposure to vapours of standard and deodorized white spirits in humans. 2. Irritation and inflammation*. *J Appl Toxicol*, 2009. **29**(3): p. 263-74.

70. Ernstgard, L., B. Lind, and G. Johanson, *Acute effects of exposure to vapours of standard and deaeromatized white spirits in humans. 1. Dose-finding study.* J Appl Toxicol, 2009. **29**(3): p. 255-62.
71. Benemei, S., et al., *TRPA1 and other TRP channels in migraine.* J Headache Pain, 2013. **14**: p. 71.
72. Bautista, D.M., et al., *TRPA1 mediates the inflammatory actions of environmental irritants and proalgesic agents.* Cell, 2006. **124**(6): p. 1269-82.
73. Zheng, L., *Intensity of odor and sensory irritation as a function of hexanal concentration and interpresentation intervals: an exploratory study.* Percept Mot Skills, 2010. **111**(1): p. 210-28.
74. Fleig, A. and R. Penner, *Emerging roles of TRPM channels.* Novartis Found Symp, 2004. **258**: p. 248-58; discussion 258-66.
75. Ambudkar, I.S., *Trafficking of TRP channels: determinants of channel function.* Handb Exp Pharmacol, 2007(179): p. 541-57.
76. Montell, C., L. Birnbaumer, and V. Flockerzi, *The TRP channels, a remarkably functional family.* Cell, 2002. **108**(5): p. 595-8.
77. Andre, E., et al., *Cigarette smoke-induced neurogenic inflammation is mediated by alpha,beta-unsaturated aldehydes and the TRPA1 receptor in rodents.* J Clin Invest, 2008. **118**(7): p. 2574-82.
78. Conklin, D.J., *Acute cardiopulmonary toxicity of inhaled aldehydes: role of TRPA1.* Ann N Y Acad Sci, 2016. **1374**(1): p. 59-67.
79. Gray, T.E., et al., *Mucociliary differentiation of serially passaged normal human tracheobronchial epithelial cells.* Am J Respir Cell Mol Biol, 1996. **14**(1): p. 104-12.
80. Marrazzo, P., et al., *3D Reconstruction of the Human Airway Mucosa In Vitro as an Experimental Model to Study NTHi Infections.* Plos One, 2016. **11**(4): p. e0153985.
81. Liu, X.Q., et al., *Interactions among Lung Cancer Cells, Fibroblasts, and Macrophages in 3D Co-Cultures and the Impact on MMP-1 and VEGF Expression.* Plos One, 2016. **11**(5): p. e0156268.
82. Pezzulo, A.A., et al., *The air-liquid interface and use of primary cell cultures are important to recapitulate the transcriptional profile of in vivo airway epithelia.* Am J Physiol Lung Cell Mol Physiol, 2011. **300**(1): p. L25-31.
83. Perdue, M.H. and D.M. McKay, *Integrative immunophysiology in the intestinal mucosa.* Am J Physiol, 1994. **267**(2 Pt 1): p. G151-65.
84. Azzopardi, D., et al., *Evaluation of an air-liquid interface cell culture model for studies on the inflammatory and cytotoxic responses to tobacco smoke aerosols.* Toxicol In Vitro, 2015. **29**(7): p. 1720-8.
85. Ji, J., et al., *Development of Combining of Human Bronchial Mucosa Models with XposeALI(R) for Exposure of Air Pollution Nanoparticles.* Plos One, 2017. **12**(1): p. e0170428.
86. Taylor, G., A.R. Macneil, and D.L. Freed, *Assessing degree of nasal patency by measuring peak expiratory flow rate through the nose.* J Allergy Clin Immunol, 1973. **52**(4): p. 193-8.

87. Strandberg, K., L. Palmberg, and K. Larsson, *Effect of formoterol and salmeterol on IL-6 and IL-8 release in airway epithelial cells*. *Respir Med*, 2007. **101**(6): p. 1132-9.
88. CICAD, *Concise International Chemical Assessment Document (Acrolein)*. Geneva: World Health Organization. 43 p. 2002.
89. Nagata, Y., *Measurement of odor threshold by triangle odor bag method*. *International Symposium on Odor Measurement. Asian Network on Odor Measurement and Control*. Japan Association on Odor Environment; Tokyo, Japan; 118–127., 2003.
90. Sim, V.M. and R.E. Pattle, *Effect of possible smog irritants on human subjects*. *J Am Med Assoc*, 1957. **165**(15): p. 1908-13.
91. Esterbauer, H., R.J. Schaur, and H. Zollner, *Chemistry and biochemistry of 4-hydroxynonenal, malonaldehyde and related aldehydes*. *Free Radic Biol Med*, 1991. **11**(1): p. 81-128.
92. Alarie, Y., *Irritating properties of airborne materials to the upper respiratory tract*. *Arch Environ Health*, 1966. **13**(4): p. 433-49.
93. Shusterman, D., E. Matovinovic, and A. Salmon, *Does Haber's law apply to human sensory irritation?* *Inhal Toxicol*, 2006. **18**(7): p. 457-71.
94. Lang, I., T. Bruckner, and G. Triebig, *Formaldehyde and chemosensory irritation in humans: a controlled human exposure study*. *Regul Toxicol Pharmacol*, 2008. **50**(1): p. 23-36.
95. Doty, R.L., et al., *Assessment of upper respiratory tract and ocular irritative effects of volatile chemicals in humans*. *Crit Rev Toxicol*, 2004. **34**(2): p. 85-142.
96. Conklin, D.J., et al., *Acrolein-induced dyslipidemia and acute-phase response are independent of HMG-CoA reductase*. *Mol Nutr Food Res*, 2011. **55**(9): p. 1411-22.
97. Kim, H., et al., *Genetic predictors for acute experimental cold and heat pain sensitivity in humans*. *J Med Genet*, 2006. **43**(8): p. e40.
98. Tanino, M., et al., *Increased levels of interleukin-8 in BAL fluid from smokers susceptible to pulmonary emphysema*. *Thorax*, 2002. **57**(5): p. 405-11.
99. Kobal, G. and T. Hummel, *Olfactory evoked potential in human*, in *Smell and taste in health and disease.*, R.L.D. T.V. Getchell, L.M. Bartoshuk, J.B. Snow, Editor. 1983, Raven Press: New York. p. 255-275.
100. Lotsch, J., et al., *Trigeminal chemosensitivity: Differences in relation to the time of the day*. *Chem Senses*, 1998. **23**(6): p. 755-9.
101. Amoores, J.E. and E. Hautala, *Odor as an aid to chemical safety: odor thresholds compared with threshold limit values and volatilities for 214 industrial chemicals in air and water dilution*. *J Appl Toxicol*, 1983. **3**(6): p. 272-90.
102. Hall, G. and J. Andersson, *Volatile fat oxidation products: 1. Determination of odour thresholds and odour intensity functions by dynamic olfactometry*. *Lebensmittel Wissenschaft und Technologie (now:LWT-Food Science and Technology)*, 1983. **16**: p. 354-361.
103. Achanta, S. and S.E. Jordt, *TRPA1: Acrolein meets its target*. *Toxicol Appl Pharmacol*, 2017. **324**: p. 45-50.

104. Trofimov, L.V., [*Comparative toxic action of crotonaldehyde and butyraldehyde*]. Gig Tr Prof Zabol, 1962. **6**: p. 34-40.
105. Leikauf, G.D., et al., *Haplotype association mapping of acute lung injury in mice implicates activin a receptor, type 1*. Am J Respir Crit Care Med, 2011. **183**(11): p. 1499-509.
106. Kasahara, D.I., et al., *Acrolein inhalation suppresses lipopolysaccharide-induced inflammatory cytokine production but does not affect acute airways neutrophilia*. J Immunol, 2008. **181**(1): p. 736-45.
107. Kawaguchi, M., et al., *Role of interleukin-17F in asthma*. Inflamm Allergy Drug Targets, 2009. **8**(5): p. 383-9.
108. Brennan, J.A., et al., *Association between cigarette smoking and mutation of the p53 gene in squamous-cell carcinoma of the head and neck*. N Engl J Med, 1995. **332**(11): p. 712-7.
109. Rahman, I., *Oxidative stress and gene transcription in asthma and chronic obstructive pulmonary disease: antioxidant therapeutic targets*. Curr Drug Targets Inflamm Allergy, 2002. **1**(3): p. 291-315.
110. Rahman, I., J. Marwick, and P. Kirkham, *Redox modulation of chromatin remodeling: impact on histone acetylation and deacetylation, NF-kappaB and pro-inflammatory gene expression*. Biochem Pharmacol, 2004. **68**(6): p. 1255-67.
111. Vanden Berghe, W., et al., *The nuclear factor-kappaB engages CBP/p300 and histone acetyltransferase activity for transcriptional activation of the interleukin-6 gene promoter*. J Biol Chem, 1999. **274**(45): p. 32091-8.
112. Sheller, J.R., et al., *Nuclear factor kappa B induction in airway epithelium increases lung inflammation in allergen-challenged mice*. Exp Lung Res, 2009. **35**(10): p. 883-95.
113. Cheng, D.S., et al., *Airway epithelium controls lung inflammation and injury through the NF-kappa B pathway*. J Immunol, 2007. **178**(10): p. 6504-13.
114. Deshmukh, H.S., et al., *Acrolein-activated matrix metalloproteinase 9 contributes to persistent mucin production*. Am J Respir Cell Mol Biol, 2008. **38**(4): p. 446-54.
115. Shapiro, S.D. and E.P. Ingenito, *The pathogenesis of chronic obstructive pulmonary disease: advances in the past 100 years*. Am J Respir Cell Mol Biol, 2005. **32**(5): p. 367-72.
116. Atkinson, J.J. and R.M. Senior, *Matrix metalloproteinase-9 in lung remodeling*. Am J Respir Cell Mol Biol, 2003. **28**(1): p. 12-24.
117. Fabunmi, R.P., et al., *Divergent regulation by growth factors and cytokines of 95 kDa and 72 kDa gelatinases and tissue inhibitors or metalloproteinases-1, -2, and -3 in rabbit aortic smooth muscle cells*. Biochem J, 1996. **315** (Pt 1): p. 335-42.
118. Murphy, A.N., E.J. Unsworth, and W.G. Stetler-Stevenson, *Tissue inhibitor of metalloproteinases-2 inhibits bFGF-induced human microvascular endothelial cell proliferation*. J Cell Physiol, 1993. **157**(2): p. 351-8.
119. Nardini, M., et al., *Acrolein-induced cytotoxicity in cultured human bronchial epithelial cells. Modulation by alpha-tocopherol and ascorbic acid*. Toxicology, 2002. **170**(3): p. 173-85.

120. Wang, L., et al., *Crotonaldehyde induces autophagy-mediated cytotoxicity in human bronchial epithelial cells via PI3K, AMPK and MAPK pathways*. Environ Pollut, 2017. **228**: p. 287-296.
121. Andel I. van, S.A., Schenk E., Rambali B., W.G.v.d. Wolterink G., L.A.G.J.M. van, and V.W. Aerts, J.G.C. van Amsterdam, **RIVM Report Adverse health effects of cigarette smoke: aldehydes; Crotonaldehyde, butyraldehyde, hexanal, and malonaldehyde**. 2006, Laboratory for Toxicology, Pathology and Genetics (TOX): Amsterdam.
122. Moretto, N., et al., *alpha,beta-Unsaturated aldehydes contained in cigarette smoke elicit IL-8 release in pulmonary cells through mitogen-activated protein kinases*. Am J Physiol Lung Cell Mol Physiol, 2009. **296**(5): p. L839-48.
123. Moretto, N., et al., *Cigarette smoke and its component acrolein augment IL-8/CXCL8 mRNA stability via p38 MAPK/MK2 signaling in human pulmonary cells*. Am J Physiol Lung Cell Mol Physiol, 2012. **303**(10): p. L929-38.
124. Valacchi, G., et al., *Inhibition of NFkappaB activation and IL-8 expression in human bronchial epithelial cells by acrolein*. Antioxid Redox Signal, 2005. **7**(1-2): p. 25-31.
125. Horton, N.D., et al., *Acrolein causes inhibitor kappaB-independent decreases in nuclear factor kappaB activation in human lung adenocarcinoma (A549) cells*. J Biol Chem, 1999. **274**(14): p. 9200-6.
126. Mio, T., et al., *Cigarette smoke induces interleukin-8 release from human bronchial epithelial cells*. Am J Respir Crit Care Med, 1997. **155**(5): p. 1770-6.
127. Yang, B.C., et al., *Crotonaldehyde-exposed macrophages induce IL-8 release from airway epithelial cells through NF-kappaB and AP-1 pathways*. Toxicol Lett, 2013. **219**(1): p. 26-34.
128. Facchinetti, F., et al., *Alpha,beta-unsaturated aldehydes in cigarette smoke release inflammatory mediators from human macrophages*. Am J Respir Cell Mol Biol, 2007. **37**(5): p. 617-23.
129. Van den Steen, P.E., et al., *Neutrophil gelatinase B potentiates interleukin-8 tenfold by aminoterminal processing, whereas it degrades CTAP-III, PF-4, and GRO-alpha and leaves RANTES and MCP-2 intact*. Blood, 2000. **96**(8): p. 2673-81.
130. Zhang, H. and H.J. Forman, *Acrolein induces heme oxygenase-1 through PKC-delta and PI3K in human bronchial epithelial cells*. Am J Respir Cell Mol Biol, 2008. **38**(4): p. 483-90.
131. Thompson, C.A. and P.C. Burcham, *Genome-wide transcriptional responses to acrolein*. Chem Res Toxicol, 2008. **21**(12): p. 2245-56.
132. Song, M.-K., et al., *Transcriptome Profile Analysis of Saturated Aliphatic Aldehydes Reveals Carbon Number-Specific Molecules Involved in Pulmonary Toxicity*. Chemical Research in Toxicology, 2014. **27**(8): p. 1362-1370.