

MULTI SOURCE HANDPHONE CHARGING SYSTEM FOR COMMUNICATION DURING EMERGENCIES

AFFAM AZUKA

UNIVERSITI SAINS MALAYSIA

2017

**MULTI SOURCE HANDPHONE CHARGING SYSTEM FOR
COMMUNICATION DURING EMERGENCIES**

By

AFFAM AZUKA

**A Dissertation submitted for partial fulfillment of the requirement
for the degree of Master of Science
(Electronic Systems Design Engineering)**

August 2017

ACKNOWLEDGEMENTS

I thank God Almighty for His gift of life and infinite mercy. All glory and supplication be to Him only.

This project would not see the light of day without the support of my supervisor, Assoc. Prof. Dr. Rosmiwati Mohd Mokhtar. My appreciation goes to her for the invaluable advice, direction, and provision in the course of executing this assignment.

I wish to thank the staff of the respective laboratories and workshops that contributed by giving me unfettered access to the facilities and equipment especially Mr. Shahidan of the Mechatronic workshop who was very helpful in the mechanical modifications and fabrication. I cannot forget to extend my appreciation to Mr. Kamarulzaman Bin Abu Bakar of the PCB laboratory and Puan Roziana Bt. Mat Said of the electronics laboratory, for their support during the production and testing period.

I want to use this opportunity to appreciate the moral and financial contribution of my family to this project and entire study. My father and mother, who always called to enquire on my progress and encourage me, my siblings, Ikenna, Eziafa, Ekene, Augustine and Ifeoma and their spouses who were always there to support financially and my nephews and nieces who provided the much-needed occasional laughter.

Finally, my appreciation goes to my friends and course mates especially Chang Pengleng and Top Sokunphal for the kind words and suggestions. Thank you.

TABLE OF CONTENTS

	Page
Acknowledgements	ii
Table of Contents	iii
List of Tables	vii
List of Figures	viii
List of Abbreviations	x
Abstrak	xi
Abstract	xii
Chapter 1 – Introduction	1
1.1 Back ground	1
1.1 Problem Statement	2
1.3 Research Objectives	4
1.4 Project Scope	4
1.5 Thesis Outline	4
Chapter 2 – Literature Review	6
2.1 Introduction	6
2.2. Human Energy.....	7
2.3 Electric Dynamo.....	10

2.3.1	Hub Dynamo	12
2.3.2	Bottle Dynamo	13
2.3.3	Permanent Magnet Motor	13
2.3.4	Input Movements for Power Production.....	14
2.3.5	Acceleration Mechanisms	17
2.4	Piezoelectric Energy.....	18
2.5	Solar Energy Harvesting	20
2.5.1	Photovoltaic Cell Operation.....	21
2.5.2	Solar Cell Technologies	25
2.6	Battery Storage	27
2.6.1	Lead Acid Battery	29
2.6.2	Nickel Based Batteries	30
2.6.3	Lithium Ion battery	30
2.6.4	Lithium Based Battery Charging	32
2.6.5	Constant Current Constant Voltage	32
2.6.6	Pulse Charging	33
2.7	Thermoelectric Energy.....	34
2.8	Summary	35
Chapter 3 – Methodology		37
3.1	Introduction	37

3.2	Project Implementation	37
3.2.1	Power Sources.....	39
3.2.2	Solar Cell Selection.....	40
3.2.3	Battery Input Selection.....	42
3.2.4	Press Input Analysis.....	43
3.2.5	Hand Crank Selection	45
3.3	Electrical and Electronic Circuitry	47
3.3.1	Input Stage Multiple Source Switching	48
3.3.2	DC-DC Regulation.....	49
3.3.3	Battery Charger	51
3.3.4	Output Stage and Implementation	54
3.4	Final System Design.....	55
3.5	PCB Manufacture and Packaging	57
3.6	Performance Evaluation	59
3.6.1	Electronic Circuit Output Tests.....	60
3.6.2	Mechanical Performance Evaluation	61
3.6.3	Phone Charging Performance Evaluation.....	62
3.6.4	Portability and Availability Tests	63
3.7	Chapter Summary.....	65
	Chapter 4 – Results and Discussion	66

4.1	Introduction	66
4.2	Circuit Performance	66
4.3	Mechanical Test Result	68
4.4	System Test Results	71
4.5	Phone Battery Charging Results	76
4.5.1	Dynamo Charging Time	76
4.5.2	Solar Panel Performance	77
4.5.3	Battery Storage Performance	79
4.6	System Availability Results	81
4.7	Torchlight Performance	82
4.8	Chapter Summary	83
Chapter 5 – Conclusion		85
5.1	Conclusion	85
5.2	Future Works	86
REFERENCES		88
APPENDICES		97

LIST OF TABLES

Table 2.1: Classifications of Human Power Mahesh et al. (2016)	9
Table 2.2: Comparison of input movements for power production (Kuipers, 2003)	15
Table 2.3: A comparison of different types of solar cells (Sharma et al., 2015)	26
Table 2.4: Comparison of related works.	36
Table 3.1: Targeted Output Values	39
Table 3.2: Power sources considerations	40
Table 3.3: Comparison of Solar Cell Types (Sharma et al., 2015)	41
Table 3.3: Voltage Output for Single Solar Cell.....	42
Table 3.4: Properties of Considered Dynamos	47
Table 3.5: Input voltage ranges.....	48
Table 3.6: Calculated component values against actual values used	54
Table 4-2 Mechanical Test Results	68
Table 4-3 System specifications	72
Table 4.4: Availability of Power Sources	81
Table 4.5: Torchlight performance	83

LIST OF FIGURES

Figure 2.1: Human power extraction process (Mahesh et al. 2016)	7
Figure 2.2: Power from body driven sources Starner & Paradiso (2004).....	8
Figure 2.3: Simplified dynamo setup (Sandhu et al., 2011)	11
Figure 2.4: Hub Dynamo (Niguchi et al., 2017)	12
Figure 2.5: Bottle Dynamo mounted aside a bicycle wheel (Waliullah et al., 2014)	13
Figure 2.6: Rotation Concept (Kuipers, 2003).....	16
Figure 2.7: Gears (Gunawan et al., 2013).....	17
Figure 2.8: Piezoelectric disc (Pandey et al., 2014).....	19
Figure 2.9: Semiconductor p-n junction cell with load (Sharma et al., 2015)	21
Figure 2.10: Equivalent circuit of PV cell (Ma et al., 2016)	22
Figure 2.11: I-V Characteristics of PV Cell (Li et al., 2011).....	23
Figure 2.12: Phone charging from solar panels (Ali, 2010)	24
Figure 2.13: Trends in PV cell technology development (Sharma et al., 2015).....	25
Figure 2.14: Battery structure (Nelson & Bolin, 1995)	28
Figure 2.15: Classification of Lithium batteries (Stan et al., 2014b).....	31
Figure 2.16: Constant Current Constant Voltage Charging (Keil & Jossen, 2016).....	33
Figure 2.17: Transient behavior of the pulse charging scheme (Tar & Fayed, 2016)	34
Figure 3.1: Flowchart for Project Implementation	38
Figure 3.2: Commercial squeeze flashlight before and after disassembly.....	43
Figure 3.3: Simulated waveform of press input method	45
Figure 3.4 Hand crank generators tested.....	46

Figure 3.5: 3-way slide switch connection for input stage	49
Figure 3.6: DC-DC converter circuit using LT1300.....	51
Figure 3.7: Battery charger circuit using LT1512	52
Figure 3.8: Output stage connection	55
Figure 3.9: Final system block design	55
Figure 3.10: Final Electronic Circuit	56
Figure 3.11: PCB outline	57
Figure 3.12: Case dimensions	58
Figure 3.13: Front view dimensions	58
Figure 3.14: Rear view dimensions	59
Figure 3.15: Electronic circuit test set up	60
Figure 4.1: Input-output voltage relationship of the electronic circuit	67
Figure 4.2: Dynamo input and output waveforms	71
Figure 4.3: Side view with torchlight turned on	72
Figure 4.4: Rear view of case.....	73
Figure 4.5: Front view of case	73
Figure 4.6: Internal outline of device.....	74
Figure 4.7: Solar panel input to device	74
Figure 4.8 Dynamo performance at 90 rpm.....	76
Figure 4.9: Solar panel performance result	78
Figure 4.10: Battery storage performance result.....	79
Figure 4.11: Comparison of phone charging time results	80

LIST OF ABBREVIATIONS

ABS	Acrylonitrile Butadiene Styrene
AC	Alternating Current
CCCV	Constant Current Constant Voltage
DC	Direct Current
EMF	Electromotive Force
GPS	Global Positioning System
LED	Light Emitting Diode
MPPT	Maximum Power Point Tracking
NiCd	Nickel-cadmium
NiMH	Nickel-metal Hydride
PCB	Printed Circuit Board
PV	Photovoltaic
PVDF	Polyvinylidene difluoride
PZT	Perovskite Zirconate Titanate / Lead Zirconate Titanate
RF	Radio Frequency
rpm	revolutions per minute
SEPIC	Single Ended Primary Inductor Converter
SoC	State-of-charge
USB	Universal Serial Bus

Sistem Pengecasan Telefon Bimbit Pelbagai Sumber bagi Komunikasi semasa Kecemasan

ABSTRAK

Situasi kecemasan boleh berlaku disebabkan berlakunya bencana alam atau apabila seseorang secara tiba-tiba tersesat di lokasi pedalaman. Dalam keadaan seperti ini, komunikasi memerlukan peranti mudah alih yang dapat berfungsi untuk menghubungi servis bantuan menyelamatkan. Namun begitu, dalam kebanyakan kes sumber elektrik akan terputus. Kebiasaannya, sumber tenaga alternatif berupaya memberikan kuasa kepada telefon mudah alih. Walau bagaimanapun sumber tenaga alternatif ini adakalanya terbatas yang menjejaskan ketersediaanya. Kajian ini bermatlamat untuk mengumpulkan beberapa sumber alternatif kepada satu unit yang boleh memberikan keupayaan kepada telefon mudah alih dengan penekanan diberikan kepada kecekapan sumber dinamo elektrik berengkol tangan. Tiga sumber kuasa digunakan iaitu kuasa manusia melalui dinamo elektrik, panel solar dan sepasang bateri boleh cas semula. Ujian dan analisa awal dilakukan dalam memilih dan memasang perkakasan. Sistem yang lengkap mempunyai suis manual bagi sumber tenaga tersebut iaitu regulasi dc-dc, susun atur elektronik pengecas bateri dan lampu suluh untuk pencahayaan. Kecekapan lebih baik sebanyak 87.5% dicapai bagi dinamo dengan sistem berupaya menghantar secara purata 400 mW semasa operasi. Purata 21 minit berlalu sebelum cas minima dihantar kepada telepon asas. Tempoh mengecas bagi telefon pintar sehingga ke aras yang ditentukan adalah masing-masing sebanyak 108 minit, 86 minit dan 72 minit bagi sumber solar, dinamo dan bateri. Unit yang dibangunkan ini berguna kepada manusia untuk dijadikan suatu alat yang boleh diharap dalam memberikan kuasa kepada telefon mudah alih bagi membolehkan mesej bantuan kecemasan dihantar.

Multi Source Handphone Charging System for Communication during Emergencies

ABSTRACT

Emergency situations may arise due to natural disaster occurrences or when chance takes one to a remote location. In settings like this, communication requires that mobile devices are powered on in the expectation of access to relief and rescue services. However, in many cases the electricity supply will be broke down. Usually, alternative energy sources provide the needed power to mobile phones in such circumstances. These alternative energy sources exhibit peculiar limitations that affect availability. This work was aimed at merging various alternative sources into a unit that will provide potential to a mobile phone with an emphasis on enhancing the efficiency of a hand-cranked electric dynamo source. Three power sources are employed which are active human power in the electric dynamo, solar panels and a pair of rechargeable batteries. Preliminary tests and analysis were conducted for hardware selection and assembly. The completed system contains a manual switch for the energy sources, a dc-dc regulation, battery charging electronic layout and a torchlight for illumination. An improved efficiency of 87.5% was achieved for the dynamo with the system able to deliver an average 0.4 W during operation. An average of 21 minutes elapsed before a minimum charge was delivered to a basic phone. The charging times for a smartphone to a determined level was found to be 108 minutes, 86 minutes and 72 minutes for the solar source, dynamo source and battery source, respectively. The developed unit is useful to people to keep it as a tool that they can rely on to power up their mobile phone in order to send emergency rescue message.

CHAPTER 1

INTRODUCTION

1.1 Background

During and after natural disasters, emergency rescue services may not perform optimally. In the case of a flood or landslide, rescuers may have to ascertain the safety level before proceeding to the disaster zone. Also, in many cases when there is no way to identify the exact location of victims, the decision as to where to concentrate a search and rescue operation is arbitrary. The survival of stranded victims at any point depends on the time they can be evacuated.

Power outages frequently occur during these floods and landslides. Such power outages could be due to either damage to power generation and transmission infrastructure or the activation of an emergency shutdown safety procedure. Such emergency shutdown could help in reducing fatalities caused by electric shock. In the absence of electricity from the grid, stranded victims may be required to power on or charge a mobile phone in order to indicate their positions by communicating with the rescue team.

Furthermore, in the tourism industry, there exist a large number of clients who aspire to embark on guided trips to remote regions of the country and the world.

Communication between tour guides and the tourists is paramount for safety purposes. For example, guided tours to mountains make use of satellite phones in communication between several camps and groups of tourists to facilitate supplies.

Another example is that of hikers and students who go on trips to remote places. They might need access to a power supply for mobile phones and global positioning system (GPS), and other low power devices.

In the situations highlighted above, it can be argued that the availability of conventional grid power is either greatly diminished or non-existent. The use of gasoline generators can only last for as long as the fuel supply is available. Also, the sizes of these gasoline generators defeat the idea of portability and “clean” energy. As such, the need for a portable alternative power source arises for such emergency situations to recharge or power up low dc power devices for communication purposes.

1.1 Problem Statement

In emergency scenarios as described previously, a low power dc supply, sufficient to charge or sustain a mobile phone is desired to be readily available, portable, efficient and reliable. Several attempts have been made to develop products which utilize alternative energy sources to combat the aforementioned challenges. Unfortunately, their suitability leaves much to be desired.

The primary shortcoming of many designs and products is that of a single input source. The single input source designs of Kale & Muhtaroglu (2010), Li *et al.* (2010), alongside commercial products like the Baylis phone chargers and Nokia DC-14 bicycle chargers (Wyche & Murphy, 2013), do not satisfy the need for redundancy.

Renewable energy has been exploited in solar chargers developed for the consumer market like the freeplay range of solar chargers and designs by Ali (2010), Brito-rojas *et al.* (2014) and Milanezi *et al.* (2014). This energy source is known to be limited by its availability at all times especially in the night and in poor lighting conditions. The little voltage generated by passive energy harvesting techniques by Zhao & You (2014), Snehalika & Bhasker (2016) makes use of vibrating piezoelectric cells. This is in the range of μV and cannot satisfy power requirements for average communication devices, which are in the range of 4.8 V to 5.2 V (Malla *et al.*, 2016).

The multiple input source attempts by Waliullah *et al.* (2014), Lande & Tupkar (2012), and Gunawan *et al.* (2014) exhibit the flaw of portability manifested by these designs. There is also the abnormal dependence of output on a single source amongst the input sources in the work by Ambrosio *et al.* (2015). This instigates a system failure whenever the availability of the primary input source is jeopardized.

The highlighted problems of redundancy, portability, availability and optimal output can be mitigated by the development of a suitably adapted mobile phone charger which will be the main research investigation in this study.

1.3 Research Objectives

The objectives of this research are;

1. To design and build a potential charging tool by using multiple input sources.
2. To enhance the system performance for greater usability and applicability.
This usability relates to portability, weight and the level of ease during use.
The applicability refers to the relevance of the unit under different scenarios.
3. To test the performance of the proposed design.

1.4 Project Scope

This work focuses on the development of the mechanical, electronic and packaging layout in a bid to achieve potential charging of the mobile phone in the absence of electricity from the grid. The energy was harnessed from a combination of the hand crank, solar and battery input sources with a common electronic circuit and its usability was determined.

1.5 Thesis Outline

The remainder of this thesis goes as follows. Four alternative energy sources are presented in Chapter 2. They are human energy using the electric dynamo, piezo generator, renewable energy using solar panels and thermoelectricity. Applicability of

these sources is highlighted. Contemporary works are reviewed along with battery storage chemistries and charging profiles concentrated on lithium batteries.

Chapter 3 presents the initial experiments and design considerations that are expedient to the development of the system. It begins with product requirement identification and goes on to determine appropriate tests and hardware selection, electronic layout design software and packaging options. The hardware implementation will be done accompanied by a second round of tests to ascertain the redundancy, portability, availability and output.

Chapter 4 publishes, discusses and analyses the prior and subsequent results detailing applicability and usability. A mechanical comparison will be made with a commercial Denuxon model Y2405 hand crank emergency charger.

Chapter 5 gives the conclusion and recommendations for further work based on the results obtained.

CHAPTER 2

LITERATURE REVIEW

2.1 Introduction

The availability of power for mobile phone charging in emergency situations depends on a plurality of factors. The primary source of power for charging mobile phones is the electrical grid using phone chargers which accompany the phones at point of sale. These chargers convert alternating current to the rated dc voltage using the appropriate circuitry. In absence of power from the electrical grid or hiking trips, most alternative substitutes for phone charging exist which explore energy harvesting techniques.

Mitcheson (2015) defined energy harvesting as the process where ambient energy is converted into electrical form and utilized by a system that is localized to the conversion setup. The ambient energy may be either of light, heat or movement. The usage of the harnessed energy by the same system differentiates the energy harvester from a renewable energy generation system.

This chapter provides a discussion on several alternative power generation methods applicable for mobile phone charging in the absence of grid power. It also

discusses previous works in between as they relate to the respective technologies. It concludes with a summary while highlighting the limitations of existing designs.

2.2. Human Energy

Starner & Paradiso (2004) investigated the magnitude of energy stored in the human body. They estimated that the energy in the human body can be calculated by leveraging on the energy in one gram of fat. A gram of fat contains 9000 calories. Converting calories to Joules,

$$\begin{aligned} 1 \text{ calorie} &= 4.184 \text{ J} \\ \therefore 9000 \text{ calories} &= 9000 \times 4.184 \\ &= 37656 \text{ J} \end{aligned} \tag{2.1}$$

For a 60 kg human, taking an average of fat in the body at 20%, the energy stored will be,

$$\begin{aligned} \frac{20}{100} \times (60 \text{ kg})(1000 \text{ g})(37656 \text{ J}) \\ = 451 \text{ MJ} \end{aligned}$$

The process of extracting human power is shown in Figure 2.1 below.

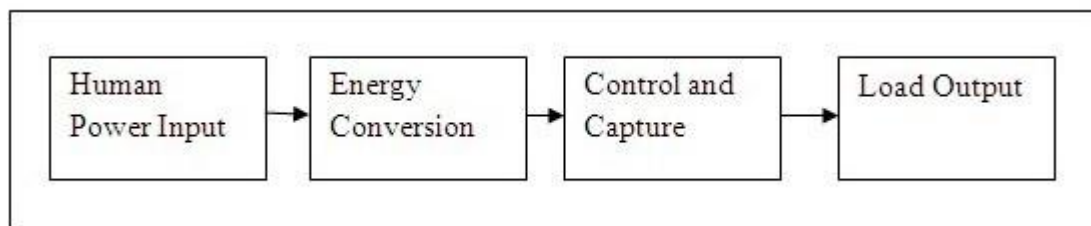

Figure 2.1: Human power extraction process (Mahesh *et al.* 2016)

Mahesh *et al.* (2016) did a classification of human power based on human effort into two groups. These are active and passive power. The human energy harnessing is said to be active when there is a conscious deliberate human effort at generating energy and has an advantage of being renewable and readily available. A downside is an accompanying fatigue and repetitiveness that results when using such devices (Robion *et al.*, 2007). Passive harnessing implies exploitation of involuntary human activities in generating energy. Scavenged energy from natural movements of the body like breathing, walking, and heat, has been discovered to be very weak in tens of milliwatts (Starner & Paradiso, 2004).

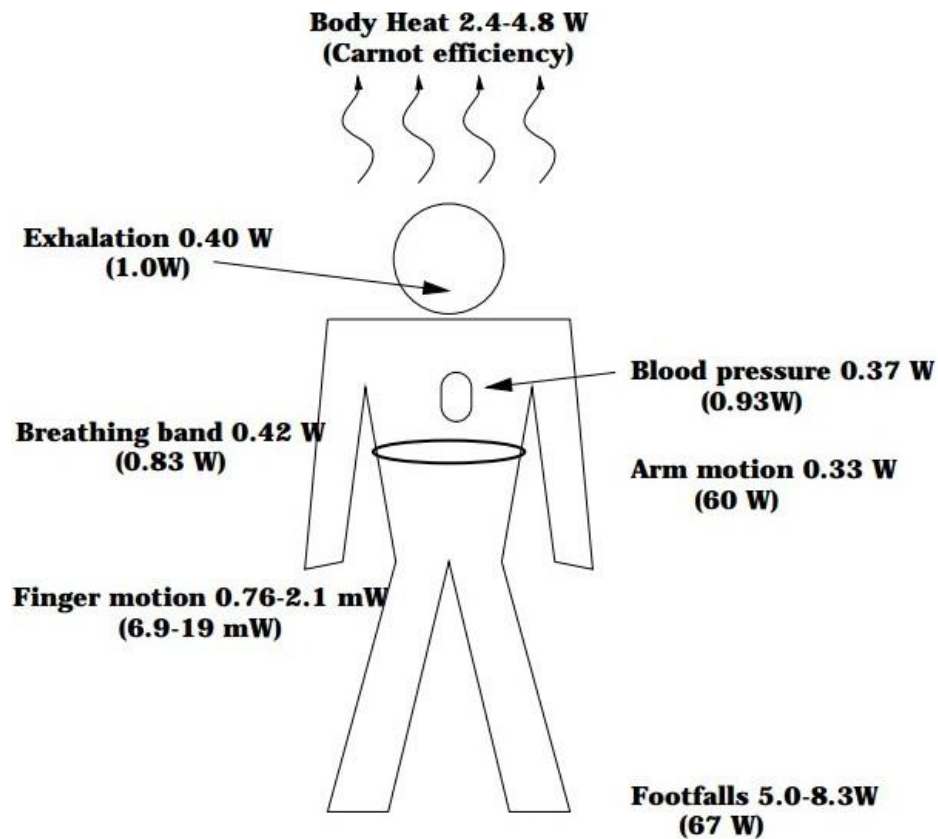

Figure 2.2: Power from body driven sources Starner & Paradiso (2004)

Figure 2.2 depicts the amount of energy harnessed from active and passive energy harnessing methods. It is seen that the passive energy from exhalation, blood pressure, and the breathing band produce the lowest energy. Thus, passive energy harvesting is rarely applicable in portable devices that require that marginal power.

Table 2.1 highlights further classifications of human power as done by Mahesh *et al.* (2016) and can help identify the ideal properties of an emergency mobile phone charger and any other designs.

Table 2.1: Classifications of Human Power Mahesh *et al.* (2016)

Broad Classification		Mobility		Output		Type of Output	
Mechanical	Electrical	Portable	Fixed or Stationary	Low or micro-power	High or macro power	Battery backed human power generator	Direct human power generators
Human mechanical effort is converted to an equivalent mechanical work	Human power is directly converted to electricity	They are low power generators	Hand cranked or pedal driven	Portable for bio-medical handheld devices	Produce 24V-120V. Hand or pedal driven electro-magnetic converters	Battery included between the output and generator to ensure steady output	Directly supply output power without an intermediate battery. Gearing and flywheel mechanism may be incorporated

2.3 Electric Dynamo

The use of the electric dynamo for electricity generation can be traced back as far as the mid-1800s. This implies that dynamos were the first electrical generators capable of delivering power for industry. Many electric power conversion devices were based, on the dynamo.

A commutator can be used with a dynamo to achieve the production of direct current. The dynamo uses rotating coils of wire and magnetic fields to convert mechanical rotation into a pulsing direct electric current through Faraday's law of electromagnetic induction which states that if an object or material that conducts electricity passes through a magnetic field, then an electric current will begin to flow through that material (Lande, 2012).

A dynamo machine consists of a stationary structure, called the stator, which provides a constant magnetic field, and a set of rotating windings called the armature which turns within that field. The motion of the wire within the magnetic field causes the field to push on the electrons in the metal, creating an electric current in the wire. Despite the fact that the invention of the alternator along with the ease of alternating current (AC) to direct current (DC) conversion has seemingly relegated the application of the dynamo to the background, they find relevance in emergency low DC power setups.

In the simplified dynamo setup in Figure 2.3, the permanent magnet rotates at an angular velocity, ω , within the solenoid. If the dynamo is attached to a bicycle, it would have the same angular velocity as that of the bicycle wheel. This rotation of the magnet will generate an alternating current output due to the sinusoidal varying electromotive force (e.m.f) (Sandhu *et al.* 2011).

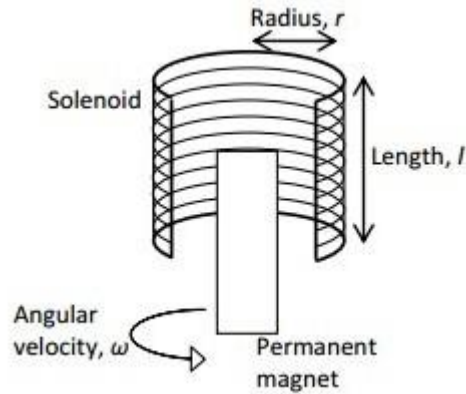

Figure 2.3: Simplified dynamo setup (Sandhu *et al.*, 2011)

Sandhu *et al.* (2011) established the feasibility of charging a mobile phone using a typical dynamo attached to a typical adult bicycle wheel. The minimum speed was estimated at 1 mph to generate sufficient power to charge a mobile phone.

Most recent applications of the dynamo are found in bicycles as replicated in Suhalka *et al.* (2014), Kale & Muhtaroglu (2010), and the Nokia DC-14 bicycle charger. These generate direct current required to power mobile phones, laptop computers or charge a battery. The dynamo is attached to the either the front or rear wheel depending on the type and orientation of the dynamo. The rotation speed of the wheel determines the power generated thus a buck- boost converter may be required to attain steady output as required. An alternator replaces the dynamo in Khan *et al.* (2015) and Ullah *et al.*

(2015). With the advantage of alternating current being generated, additional hardware is required to convert to appropriate output for mobile phone charging.

Modifications aimed at achieving a measure of redundancy in the above single source bicycle dynamo chargers have been made by Lande (2012), Amritanand *et al.* (2016) and Waliullah *et al.* (2014) with the incorporation of solar panels as a second energy source in addition to the bicycle dynamo input. The absence of portability in all discussed systems, pose as a limitation in emergencies.

2.3.1 Hub Dynamo

The hub dynamo is a small electrical generator in that its output is alternating current. It is heavy and large in size but has a more stable output at a minimum speed of rotation with less noise (Niguchi *et al.*, 2017; Ukaji *et al.*, 2014). The rotor and stator have an equal number of pole pairs and claw poles with the yoke having a winding by a single coil as depicted in Figure 2.4. It is usually fitted with the wheel hence installation requires some skilled personnel.

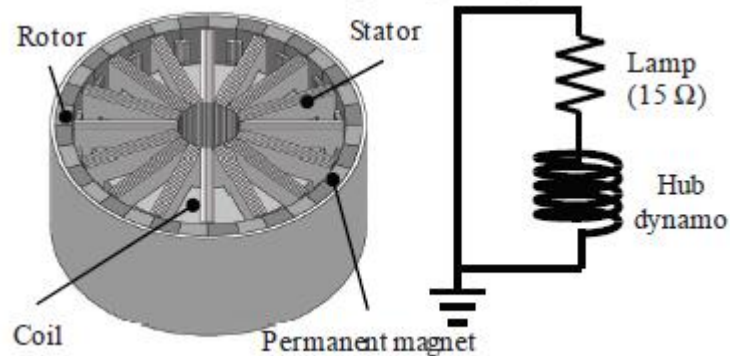

Figure 2.4: Hub Dynamo (Niguchi *et al.*, 2017)

2.3.2 Bottle Dynamo

The bottle dynamo (Waliullah *et al.*, 2014), on the other hand, is lighter and cheaper than the hub dynamo. Also, referred to as the “sidewall” dynamo, it is named after its bottle-like shape. The output is usually direct current and there is a relatively easy installation by the side of the bicycle wheels. Typical power ratings are 12 V 6 W and 6 V 3 W (Kongsiriwattana & Gardner-Stephen, 2016). A bottle dynamo mounted aside a wheel is shown in Figure 2.5. Electrical energy is generated by the use of friction contact between the tire and a friction roller on the dynamo. Occurrences of slips under rainy conditions occasionally result in poor performance.



Figure 2.5: Bottle Dynamo mounted aside a bicycle wheel (Waliullah *et al.*, 2014)

2.3.3 Permanent Magnet Motor

Permanent magnet dc motors have been used as an electric dynamo in numerous studies and commercial products. A drastic reduction in product size and increased portability is achieved with the use of a permanent magnet dc motor as a dynamo. A

motor can be used backward to achieve the same output as the electric dynamo by reversing the input to it. Typically, the input of a motor is voltage and current to produce torque and rotation. Inverting this input to output by applying torque and rotational velocity will give voltage and current as output thus emulating the dynamo. This implies that the electrical generator and electrical motor can be modeled by the same equations (Kuipers, 2003).

2.3.4 Input Movements for Power Production

Kuipers (2003) work explored the active power harvesting input movements for the development of a human powered mp3 player. The six input movements namely turning, twisting, swinging, pushing and bending, shaking and pulling were identified and compared as shown in Table 2.2. These active power methods generate more power than passive methods (Kuipers, 2003). As can be seen, the continuity and spontaneity of output give the advantage to the turning handle method. This is commonly called hand cranking. The least suitable is the swinging method. This is largely due to the hazard associated with the method.

Table 2.2: Comparison of input movements for power production (Kuipers, 2003)

Movement	Type	Power	Space	Mass	Environment
Twisting	Rotational; discontinuous	12.6 W	Small	Light	No nuisance in surrounding space; not instantly clear something is powered.
Turning handle	Rotational; continuous	21 W	Small	Light	No nuisance in surrounding space; clear something is powered.
Shaking	Translational; continuous	0.4 W	Medium	Medium	Noise and motion in surrounding space; not clear something is powered.
Pulling	Translational; discontinuous	23 W	Medium	Light	Motion into surrounding space; clear that something is powered.
Swinging of mass	Rotational; continuous	25 W	Medium to large	Heavy	Hazardous for surrounding space; not instantly clear something is powered
Pushing and bending	Translational; discontinuous	20 W	Small	Light to medium	No nuisance in surrounding space; not instantly clear something is powered.
Squeezing/pressing	Translational; discontinuous	6 W	Small	Light	Noise and motion in surrounding space; not clear something is powered.

The actual test models compared turning a handle and pulling. Turning a handle is the same as rotation. The turning handle method was recommended due to its reliability of 82% compared to the 75% reliability of the pulling method (Kuipers,

2003). Figure 2.6 shows the mechanism of active power input movement by rotation. The gear system can be seen to function as a means to increase the dynamo's rotational speed.

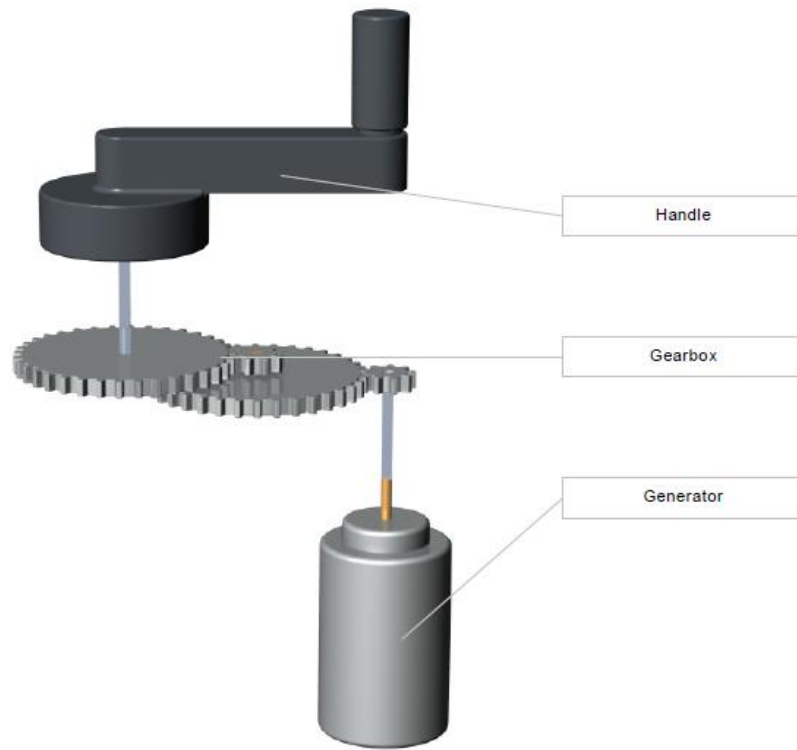

Figure 2.6: Rotation Concept (Kuipers, 2003)

The squeeze/press method is applied in few commercial products. The Nissho Aladdin power charger employs this method (Starner & Paradiso, 2004). There has not been much research into the functionality and applicability of this method.

2.3.5 Acceleration Mechanisms

Pedal powered dynamos as employed in bicycles are able to effortlessly achieve the minimum output required to charge a mobile phone. Unfortunately, the quest for portable designs implies that permanent magnet dc motors or generators have to be used as a substitute to bigger dynamos. The ability of human power alone to achieve the required minimum rotation speed is limited. Applying gear mechanisms help achieve a minimum speed of rotation. The gear mechanism comprises of two or more gears with unequal sizes. The gear ratio and position of the gears determine the rotation speed achieved. The gear ratio can be determined by either of the number of teeth on the gear or the diameter as shown in Figure 2.7.

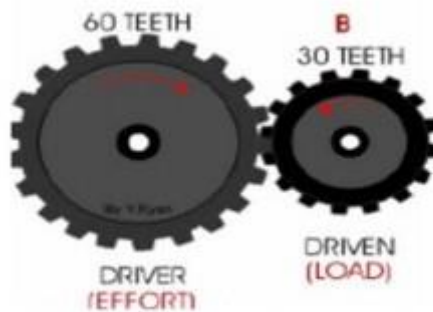

Figure 2.7: Gears (Gunawan *et al.*, 2013)

The gear ratio can be calculated by

$$GR = \frac{n_{out}}{n_{in}} = \frac{d_{out}}{d_{in}} \quad (2.2)$$

where GR is the gear ratio,

n is the number of teeth,

d is the diameter of the gear.

For the gears shown in Figure 2.7, the driven speed increases by the ratio relationship between it and the driver.

Gearing mechanisms can be designed to function in all the input movements for human power production depending on the design. It is mostly used due to the ease of design. Other more complicated mechanisms are the spring coil mechanism, rack-pinion mechanism and the roller mechanism (Vishnoi & Agrawal, 2014).

2.4 Piezoelectric Energy

In piezoelectric energy harvesting, the primary hardware for generating energy is the piezo generator. It comprises of a number of layers of piezoelectric materials (Snehalika & Bhasker, 2016). Piezoelectric materials have the ability to produce an electrical charge in event of mechanical deformity. Inversely, these materials also suffer physical deformity in the presence of an electric field.

Harnessing piezoelectricity is closely linked to human power. This is evident in the fact that Xie & Cai (2015), along with the majority of researchers have concentrated on walking shoes to harness energy. Similarly, Pandey *et al.* (2014) claimed to have developed a mobile phone charger that helps to attain full charge after less than three hours of walking. Figure 2.8 shows a piezoelectric disc. (Ambrosio *et al.*, 2011)

investigates the suitability of both the series and parallel connections of the PZT (perovskite zirconate titanate) cantilever in powering very low power electronics.



Figure 2.8: Piezoelectric disc (Pandey *et al.*, 2014)

Jansen (2011) comparison of the output power from several studies concludes that output of piezoelectric systems is in the milliwatt ranges, and thus is insufficient to charge a mobile phone. A second attempt by Ambrosio *et al.* (2015) designed a multiple source system with a combination of solar, piezoelectric and RF (Radio Frequency) energy harvesting inputs. The power output of the solar panel compensates for the meager values of the other input sources, and thereby giving sufficient power to charge a mobile phone. The failure of the solar input will result in total system failure.

The most recent effort by Snehalika & Bhasker (2016) succeeded in fully charging a super capacitor after 10 minutes using PVDF (polyvinylidene difluoride) material as against lithium niobate and PZT. This point to the fact that even with the high conversion efficiency of the piezoelectric element, the cost and size capable of

generating enough power to charge a battery is humongous (Takahasi *et al.*, 2006). This limitation is overcome in Ahmed Jamal *et al.* (2014) who claimed to use a voltage quadrupling circuit to harness energy from several sound sources for battery charging.

2.5 Solar Energy Harvesting

Solar energy as an alternative energy source has matured over time. The merits of this renewable energy source as a form of “clean energy” alongside abundance, has inspired continuous work on improving output parameters (Soh & Tiew, 2014). The energy from the sun is free to all and sundry and the nuclear fusion reaction that produces it leaves no toxic by-products. The expense incurred in harnessing solar energy is on hardware like solar cells and other associated equipment. This is in contrast to power production using fossil fuels that involve big expensive pumping machines alongside the noise pollution (Sharma *et al.* 2015).

There are few limitations to this energy source. The sun is not available at night. Besides, the energy output from the sun is not always constant. This can be caused by changing weather conditions. For example, the sun’s radiation during winter is less intense compared to that during summer (Kongsiriwattana & Gardner-Stephen, 2016).

2.5.1 Photovoltaic Cell Operation

The solar harvesting exploits the effects of incident light on the photovoltaic (PV) cell which is then converted into electricity (Ali, 2010). The PV cell is fundamentally a p-n junction having no applied voltage. The conversion of light energy to electrical energy is a flow of photons. This is similar to the flow of electrons and known as the photoelectric effect. The minority carriers generated by the light are collected at the p-n junction. Here, the excited electrons move to the n-region in the same way as the holes move to the p-region. The holes thus become majority carriers (Soh & Tiew, 2014). Figure 2.9 illustrates the effect of the absorbed light. The charge carriers which are the holes (p-type) and electrons (n-type) separate and move to their respective electrodes thereby establishing a potential difference across the p-n junction.

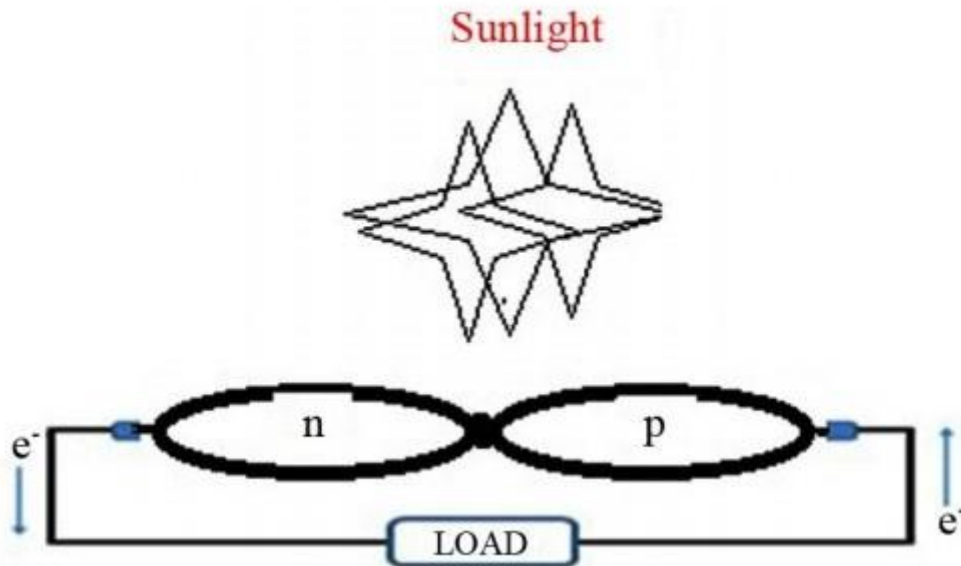

Figure 2.9: Semiconductor p-n junction cell with load (Sharma *et al.*, 2015)

It can be seen from the equivalent circuit of the PV cell in Figure 2.10 that the solar cell consists of a current source with a reverse diode D , shunt resistance R_{sh} , and series resistance R_s . V is the output voltage. The series and shunt resistances, R_s and R_{sh} represent actual internal resistance losses (Ma *et al.*, 2016).

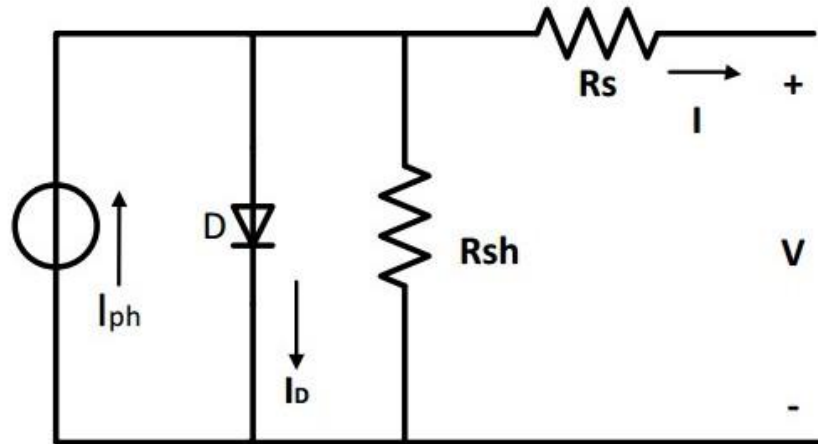

Figure 2.10: Equivalent circuit of PV cell (Ma *et al.*, 2016)

The current generated by the current source (I) is proportional to the incident light. In a no-load condition, the generated current flows through the diode with negligible losses. The current is stable at this point. A connected load will draw current away from the diode. The current drawn depends on the load current and a continuous increase in load current will result in the diode being insufficiently biased. Thus, the previously stable voltage across the diode diminishes. The resultant I-V characteristics of the photovoltaic cell are illustrated in Figure 2.11 can cause power loss while in service.

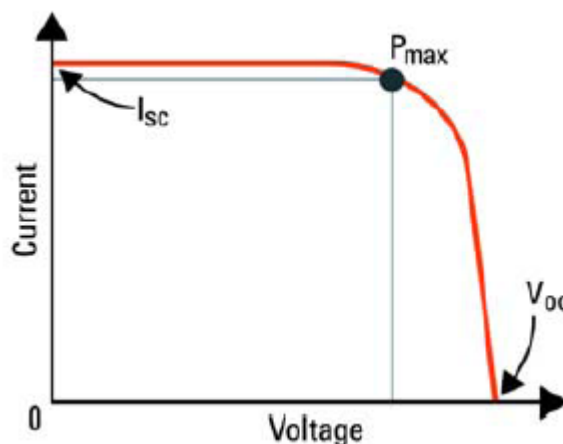

Figure 2.11: I-V Characteristics of PV Cell (Li *et al.*, 2011)

Many solar energy applications in high power electric grid generation, implement maximum power point tracking (MPPT) to curtail this characteristic and increase their efficiency. The MPPT is not necessary for low power applications like mobile phone charging. For example, Al-Mamun *et al.* (2013) ignored the MPPT in the development of a system capable of delivering 13.16 W per hour. A lead battery serving as the storage device from the solar panel was connected to an inverter circuit to generate alternating current output.

Brito-Rojas *et al.* (2014) presented a cost-effective prototype of a smartphone battery charger. The battery control algorithm uses a PIC microcontroller in charging a 9.6 V lead acid battery. The battery, in turn, can be used to simultaneously charge a minimum of 4 phones and other mobile devices. A similar arrangement for a single phone was developed in Ali (2010) where three solar panels are paralleled to charge NiCd batteries which in turn provide power to the phone as illustrated in Figure 2.12.

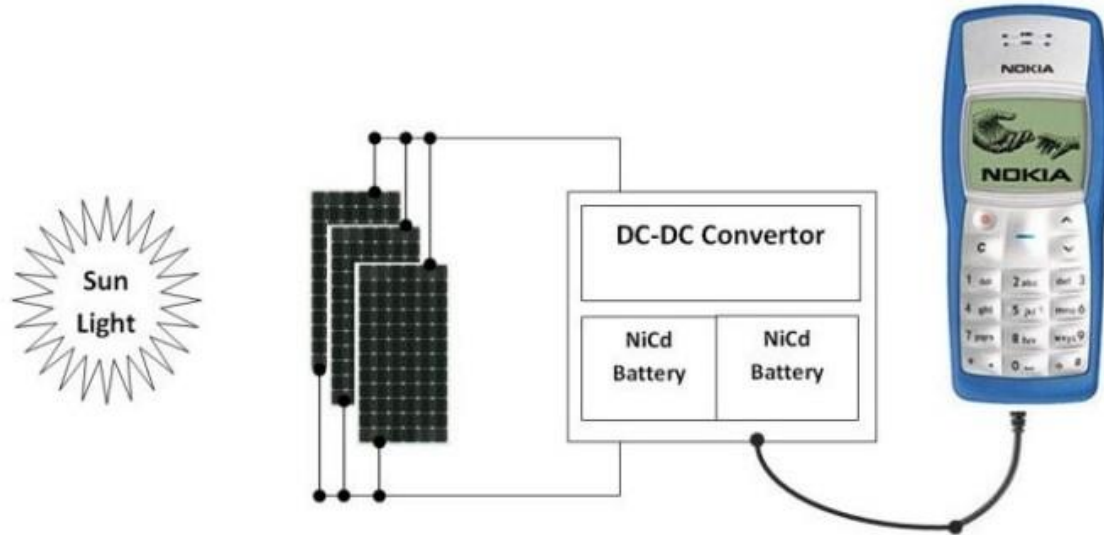

Figure 2.12: Phone charging from solar panels (Ali, 2010)

It can be noticed that batteries are used as a means to curtail the effect of the abnormal I-V characteristic of the photovoltaic cell. This is employed in many applications to provide stable output irrespective of the load current. Akin (2012) added a constant voltage MPPT to this strategy in the development of a solar USB (Universal Serial Bus) battery charger which boasts of having a 92.6% efficiency. The system makes use of a voltage and current controller in keeping the input to a boost converter tied to 3 V.

The capability to charge a cell phone with a solar panel in poor indoor lighting conditions is investigated in Milanezi *et al.* (2014) and Li *et al.* (2011). The former makes use of amorphous silicon material with an 8 W LED lamp placed 13 cm away to generate 2.8 V. An addition of a boost converter succeeds in achieving a 5 V output. The latter failed to generate sufficient power for the specified purpose under normal