

Transient behaviour of induction motors in island conditions due to interruptions in the ship's electrical power supply

Bachelor's dissertation



Facultat de Nàutica de Barcelona
Universitat Politècnica de Catalunya

Student:

Harmanpreet Singh Rattan

Director:

Dr. Pau Casals Torrens

Bachelor's degree in Marine Technologies

Barcelona, 19th of October of 2017

Summary

The focus present dissertation was a problem that occurs in industrial installations and ships. The said installations experience overvoltage in case of power cut. This problem is a result of installing capacitive compensation parallel to motors. This dissertation studied this problem with two different electric motors widely used in big installations.

The motors were tested in laboratory in different operational conditions; with different connections (D and WYE), with different loads and without load and with and without capacitive compensation. The capacitor bank, source of capacitive compensation, was also connected in D and WYE during the tests.

The overvoltage was observed with capacitive compensation only when the capacitor bank was connected in D and the motors were connected in WYE. The mechanical load on the shaft has determined the peak value of the transient voltage and the duration of the waveform.

The laboratory testing circuits, in which the overvoltage was observed, were recreated in Matlab to validate the results obtained in real-world. The simulation results were very similar to their real-world counterparts in 3 of the 4 cases.

In conclusion, the overvoltage has manifested when the voltage received by the capacitor bank was superior than the motor's. The load has also played an important role in determining the peak value of transient of waveform.

Table of contents

1	Introduction.....	8
2	Mathematical model.....	10
2.1	Physical aspects	10
2.1.1	Working principle of a motor	11
2.2	Equivalent circuit	11
2.2.1	Approximant equivalent circuits.....	13
2.3	Characterization of induction motor	14
2.3.1	Blocked rotor test.....	16
2.3.2	No-load test	17
3	Laboratory Testing	24
3.1	Testing installation.....	25
3.1.1	Electric circuit	30
3.2	Formula-based analysis.....	34
3.2.1	Dynamic analysis	35
4	Test's results.....	36
4.1	Results' analysis.....	46
5	Matlab simulation	47
5.1	Simulation results	51
5.1.1	Simulation results' analysis.....	53
6	Conclusion	56
7	Bibliography	57

Table of figures

Figure 1: Motor's parts.....	10
Figure 2: Exact equivalent circuit	12
Figure 3: Exact equivalent circuit with load resistance	13
Figure 4: Approximant equivalent circuit without load	14
Figure 5: Approximant equivalent circuit with load	14
Figure 6: Squirrel cage induction motor.....	15
Figure 7: Wound rotor induction motor.....	15
Figure 8: (Right) D connection and (Left) WYE connection	15
Figure 9: Testing circuit (Source: Máquinas eléctricas: Pau Casals Torrens [1])	16
Figure 10: The V_o^2 - P_o graph of motor no. 1.....	18
Figure 11: The V_o^2 - P_o graph of motor no. 2.....	19
Figure 12: Simulation of exact equivalent circuit in no-load condition (motor no. 1)	21
Figure 13: Simulation of exact equivalent circuit in blocked rotor condition (motor no. 1) ...	21
Figure 14: Simulation of exact equivalent circuit in no-load condition (motor no. 2)	21
Figure 15: Simulation of exact equivalent circuit in blocked rotor condition (motor no. 2) ...	22
Figure 16: Power triangle	24
Figure 17: The contactor	26
Figure 18: The capacitor bank	26
Figure 19: The tachometer (On far right), the mechanical brake (On far left) and the ammeter (Behind the tachometer).....	26
Figure 20: The analyser	27
Figure 21: Datawatch Pro's main window.....	27
Figure 22: The analyser mounted in the protective case	28
Figure 23: Connection diagram of the analyser	28
Figure 24: Circuit implementation of the analyser.....	29
Figure 25: The Oscilloscope.....	29
Figure 26: The motor connected in D.....	30
Figure 27: The motor connected in WYE.....	30
Figure 28: Motor and capacitor connected in WYE.....	30
Figure 29: Motor connected in WYE and capacitor bank in D.....	30
Figure 30: Motor connected in D and capacitor bank in WYE.....	31
Figure 31: Motor and capacitor connected in D	31
Figure 32: Phase-neutral connection of the capacitor and the motor	31
Figure 33: Asynchronous Machine (SI units)	47
Figure 34: Asynchronous machine's parameters window.....	48
Figure 35: Three-phase programmable voltage source	49
Figure 36: Three-phase load.....	49
Figure 37: Three-phase breaker	49
Figure 38: Three-phase V-I measurement.....	50
Figure 39: Voltage measurement	50
Figure 40: Scope	50
Figure 41: Step	50
Figure 42: Gain	50
Figure 43: Ground	51
Figure 44: Powergui	51
Figure 45: Simulation circuit.....	51
Figure 46: Test no. 5 - Simulation result.....	52
Figure 47: Test no. 5 - Lab test result	52

Figure 48: Test no. 7 - Simulation result.....	52
Figure 49: Test no. 7- Lab test result	52
Figure 50: Test no. 30 - Simulation result.....	52
Figure 51: Test no. 30 - Lab test result	52
Figure 52: Test no. 32 - Simulation result.....	53
Figure 53: Test no. 32 - Lab test result	53
Figure 54: Test no. 34 - Simulation result.....	53
Figure 55: Test no. 34 - Lab test result	53
Figure 56: Transient three-phase voltage waveform	54
Figure 57: Transient waveform of the three-phase current.....	55
Figure 58: Transient waveform of the RMS.....	55

Table of tables

Table 1: Rated values of motors.....	14
Table 2: No-load test results	18
Table 3: Mechanical losses of motors	19
Table 4: No-load and blocked rotor tests' results	20
Table 5: Motors' parameters.....	20
Table 6: Simulated no-load and blocked rotor test.....	23
Table 7: Simulated value of impedances.....	23
Table 8: Different test conditions.....	33
Table 9: Table of equivalent impedances.....	34
Table 10: Table of results of laboratory tests.....	45
Table 11: Relation between power and inertia (Source: Máquinas eléctricas. Jesús Fraile Mora [2]).....	48
Table 12: Values of mutual induction and inertia of simulated motors.....	48
Table 13: Simulation's waveforms	53
Table 14: Comparison of simulation results and test results	54

1 Introduction

The invention of alternative current motor revolutionized the world. It is efficient and requires minimal maintenance. Nowadays, these motors can be spotted at any industry. The main reason of that is its scalability. They can be as big as or as small as its task requires it to be. Another reason for its popularity is its versatility. By making small modifications in its design, the optimal operational point can be changed. In other words, it is relatively easy to tweak its optimal power, speed and torque output.

The most well-known and popular motor in industrial environment is the three-phase induction motor. The principal behind the induction motor, also known as alternative current motor, functioning is the same as the generator of the alternative current, i.e., electromagnetic induction. Since the working principle of these two machines is the one and same, theoretically, the induction motor can operate as the generator and supply current to devices connected on same network. And it does that, for a very little duration, every time the power supply is shut down.

In normal operational conditions this phenomenon is not harmful. Because the current that the motor produces can be considered non-existent compared to what is being supplied to other equipment by the network. The problem begins when there is a power cut and the motor's operation is interrupted. Now the current that is being produced by the motor is reaching to the other electrical devices that are connected on the same network or grid as the motor.

The magnitude and frequency of the current and voltage are anything but nominal. The electronic equipment that is highly sensible to small variations of the current are in a great danger under these circumstances. The worst case scenario is when the motors have capacitive compensation because it can produce overvoltage.

The overvoltage derived from capacitive compensation can corrupt the data, damage the internal components or even cause burn in the whole equipment. This phenomenon takes place on ships and in industrial installations. That's why throughout this dissertation there will be no distinction between ship and industrial network.

So the objective of this dissertation is to analyse this transient behaviour of the motor when there is a power cut and it has capacitive compensation. Different steps to achieve that goal are listed below:

- The transient behaviour will be studied on two different types motors that are widely used in the industry.

- It will be studied in different operational conditions for each motor.
- It will be studied that how the load connected to the motor can affect the current produced by it and how the absence of load contributes to this phenomenon.
- It will be studied while the capacitor bank is connected parallel to the motor.

Later on, the results gathered during the lab experiments will be compared with the simulated results on Matlab. The outcomes from the real-world experimentation and computer simulation should be very similar if not the same.

2 Mathematical model

2.1 Physical aspects

Before looking into a model that represents an electric motor it is pertinent to discuss about different parts of motor and how they interact with each other. That's why this part is dedicated to the main parts of the motor and their function.

A three phase induction motor, or any electric motor for that matter, consists of two major parts: a stator and a rotor. The rotor is not attached to the stator in any way; there is a small separation distance between the two known as air gap. The rotary movement is the result of interaction of magnetic fields created by the windings of the rotor and stator.

The stator consists of frame, core and winding. The stator frame is an enclosure and the outermost part of the induction motor. It houses the junction box where cables are connected that provide electric current to the motor. It acts as a protection from any external damage that might occur. It provides mechanical strength to the internal components.

The stator core's main purpose is to serve as housing for the stator windings. The magnetic flux flows through the core and to reduce the eddy currents the core is made laminated. It has various equidistant peripheral slots parallel to its central axis.

The rotor is the part of the induction motor that is responsible for the rotary movement. It has a shaft that connects to the mechanical load and in the middle is located a laminated structure of cylindrical form that houses slots for the winding. This winding can be of two type:

- i. Conventional three phase winding made of copper wire
- ii. Squirrel cage winding.

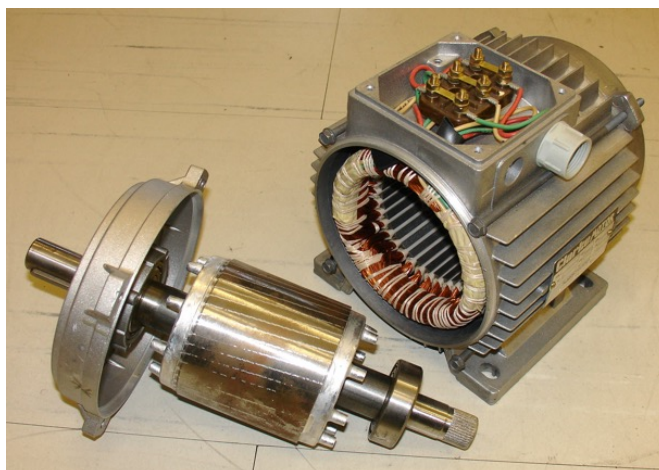

Figure 1: Motor's parts

The squirrel cage winding consists of aluminium or copper bars that are inserted in the slots previously mentioned. At the extremes of the cylinder these bars are welded to the rings made of same material as the bars. This way the rings and the bars form a close circuit.

The induction motors are named depending on their rotor configuration. The ones with squirrel cage windings are known as squirrel cage induction motor. The ones with conventional windings are known as wound motors. The latter is also known as slip ring motors due to the fact that it has slip rings mounted on its shaft that are used to add resistance to the rotor. By doing this, the torque-speed curvature can be changed to obtain desired starting torque.

2.1.1 Working principle of a motor

The current enters through the junction box in the stator windings. When it starts circulating through the stator windings it creates a rotary magnetic field. Due to electromagnetism, this magnetic field induces current in rotor windings, i.e., the electrons in the rotor windings start moving in a particular direction.

The current that now circulates through the rotor windings also creates a rotary magnetic field. The two rotary magnetic fields interact with each other. The result of this interaction is the rotatory motion of the rotor.

2.2 Equivalent circuit

In order to analyse and study machine's behaviour it is necessary to represent its functionality in a comprehensive way. This representation must englobe every key aspect of the machine; every important component must be included in the representation. It has to be sufficient to understand that how the machine works, what are its parameters and how these parameters interconnect with each other to make the machine functional.

In induction motors, this representation is achieved by Steinmetz equivalent circuit. This equivalent circuit features all the essential components required for the analysis of induction motors. That's why, it is featured in almost every book that talks about induction motors.

Although the induction motor is a three-phase machine, the equivalent circuit is a single-phase representation for the sake of simplicity. For that reason, when using this representation one must procure to use phase voltage since the connection is phase-neutral.

The circuit that is shown below is known as exact equivalent circuit. Obviously, the actual motor components are not connected in this manner. However, it does give an idea that how these pieces interact and depend on each other. The main purpose of this circuit is to determine that how much current passes through each winding which will ultimately be used to calculate the power output.

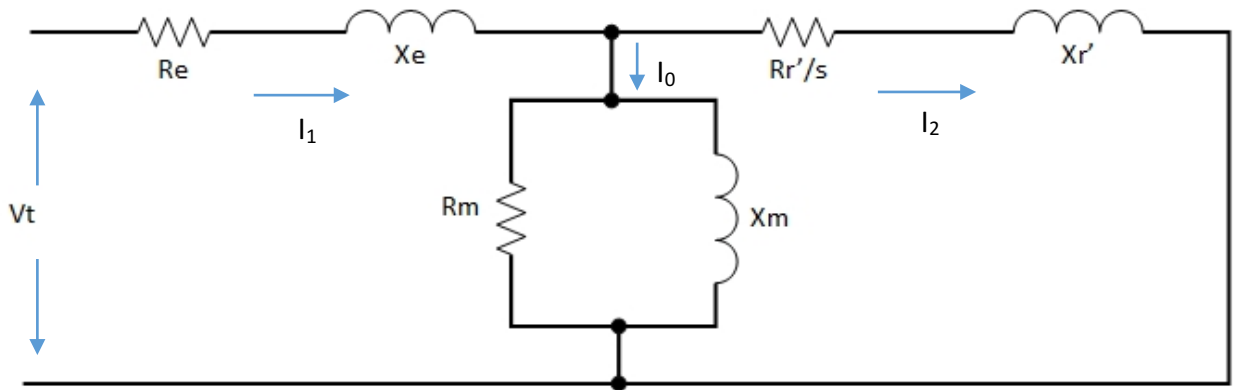

Figure 2: Exact equivalent circuit

Where:

R_e = Stator resistance (Ω)

X_e = Stator leakage reactance(Ω)

R_r'/s = Rotor resistance referred to stator(Ω)

X_r' = Rotor leakage reactance referred to stator(Ω)

R_m = Core losses resistance(Ω)

X_m = Magnetizing reactance(Ω)

The current that enters through stator (I_1) is divided into two currents, one that flows through rotor (I_2') and another one that flows through magnetizing branch (I_0). The amount of current that passes through the two fractions depends directly on the rotational speed and torque output. These two parameters decide the value of slip (s) that is illustrated in the circuit. So, the rotor resistance depends on the speed and the torque output of the motor.

The magnetizing branch is not a physical component of the induction motor. Rather it represents the impedance that is imposed by the core of the stator. The current that flows through this branch is the one responsible for creating the rotating magnetic field that induces current in the rotor.

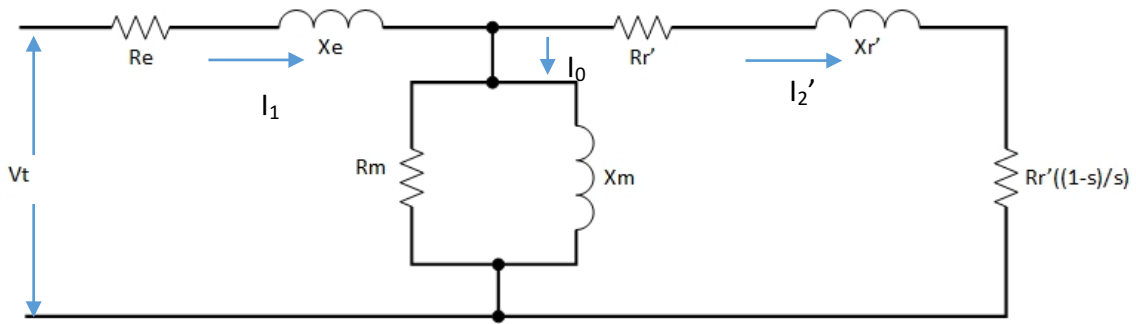

Figure 3: Exact equivalent circuit with load resistance

In order to make the calculations easier the rotor resistance is divided into two elements.

$$Rr' + Rr' \left(\frac{1-s}{s} \right) = Rr' + Rr' \left(\frac{1}{s} - 1 \right) = Rr'/s \quad (2.1)$$

$Rr' \left(\frac{1-s}{s} \right)$ = Resistance that represents mechanical load on the induction motor.

With this distinction it is very easy to calculate the developed power by the motor as illustrated in the formula below.

$$P_i = 3 \cdot (I_2')^2 \cdot [Rr' \left(\frac{1-s}{s} \right)] \quad (2.2)$$

By subtracting the mechanical losses of the motor from the developed power the total output power is obtained.

$$P_0 = P_i - P_m \quad (2.3)$$

The difference between two currents, I_0 and I_2' , value is rather big in different operational states. Therefore, an approximate equivalent circuit is used in which either current is considered negligible depending on operational state.

There are two main states under which an induction motor can operate, i.e., under load or no load. The distinction between these two operational states is important because the presence or absence of load determines the path that current takes after node of magnetizing branch.

2.2.1 Approximant equivalent circuits

When there is no load at the rotor a small fraction of current passes through rotor, enough to produce sufficient torque to overcome friction and winding losses associated with rotation. So it can be considered negligible. Under this condition the majority of current is used to produce reactive power that generates the magnetic field, i.e., $I_1 \approx I_0$.

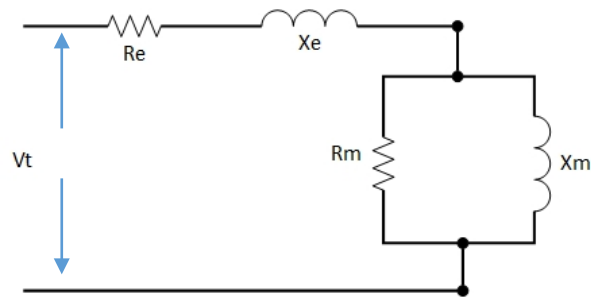

Figure 4: Approximant equivalent circuit without load

The R_m in the magnetizing branch represents the resistance of air in air gap. It is usually very high. For that reason, many times it is omitted from the circuits all together because very little amount of current passes through there. It makes the calculations easier.

When the motor is rotating something i.e. there is a load connected, it needs torque and consequently power to rotate that load. Under load, the majority of current passes through the rotor and the magnetizing branch's current can be neglected, i.e., $I_1 \approx I_2'$. This current is used to calculate the power output of the induction motor. This mechanical power depends highly on the value of slip.

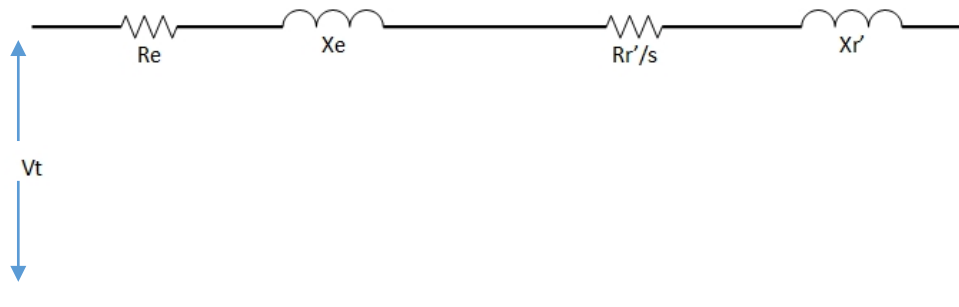

Figure 5: Approximant equivalent circuit with load

2.3 Characterization of induction motor

For the purpose of this dissertation, parameters of two different induction motors are determined. One is a squirrel cage induction motor and another one is a wound rotor motor. The very first step towards the characterization is to collect the rated values of the motor. It is easily done by extracting information from the nameplate that is attached motor housing.

	Motor no. 1	Motor no. 2
Motor type	Squirrel cage induction moto	Wound rotor induction motor
Rated voltage	220/380 V	220/380 V
Rated current	4.8/2.8 A	2.5/1.4 A
Nominal power	1000 W	600 W
Rated speed	1420 rpm	1500 rpm
Frequency	50 Hz	50 Hz
Power factor	-	0.8

Table 1: Rated values of motors

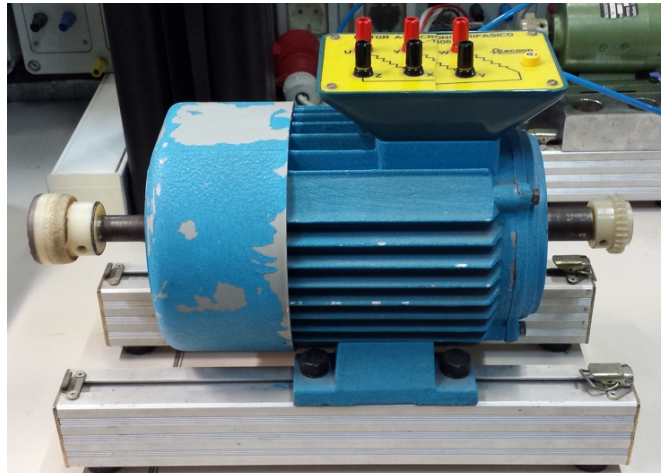

Figure 6: Squirrel cage induction motor

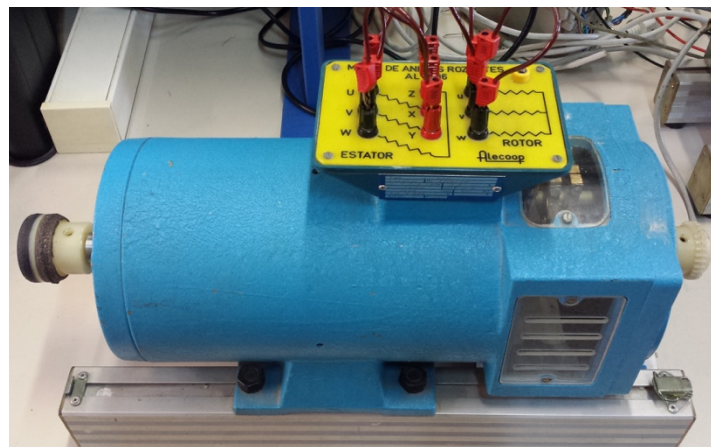

Figure 7: Wound rotor induction motor

As it can be seen, there are two rated voltages and currents for each motor. That is why because three phase machines allow two different types of connection, WYE and D (delta). The type of connection depends on the nominal voltage of the network. If the voltage is the same as the motor's, then the connection must be in D. If the voltage is 3 square root times the nominal voltage of motor, then the connection must be done in WYE.

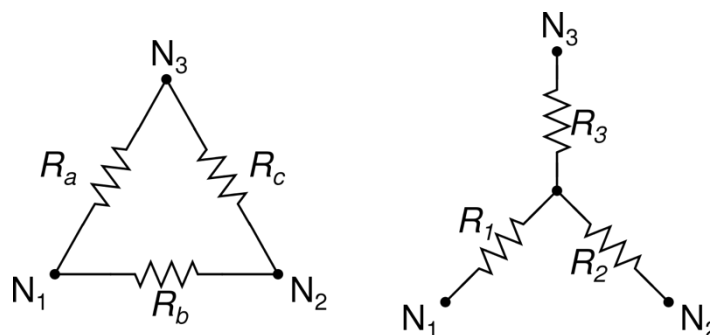

Figure 8: (Right) D connection and (Left) WYE connection

The approach taken in determining these motors' parameters is the most traditional one. It consists of doing two tests on subject motors, namely, no-load test and locked-rotor test, and measuring the following parameter:

- Active power (W)
- Voltage (V)
- Current (A)
- Reactive power (VAr)
- Apparent power (VA)
- Power factor

With this data collected from the both tests above mentioned resistances and leakage reactance are calculated. Various formulas and assumptions are employed in the process of calculation.

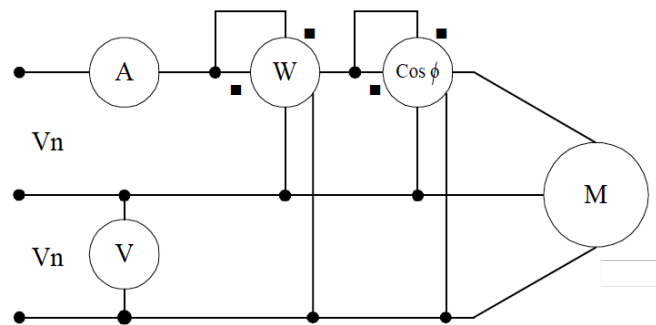

Figure 9: Testing circuit (Source: Máquinas eléctricas: Pau Casals Torrens [1])

Both tests are done at a room temperature of 24 °C. Before commencing the tests, the stator resistance of both motors is measured with an Ohmmeter. To measure the parameters above mentioned, following circuit is implemented:

2.3.1 Blocked rotor test.

As the name suggests, during this test the rotor is blocked, i.e., there is no rotatory movement. When there is no rotation the value of slip (s) is 1. Once the rotor is secured, with the help of variable voltage source small voltage increments are applied. The voltage supply must be stopped when the current reaches its rated value. This reading is named as I_{RB} .

Apart from the current following data is collected:

V_{RB} : The value of this voltage is well below the rated one. Since the voltage is small and the resistance of the magnetizing branch is big, the intensity does not flow through there.

P_{RB} : It is the electric power consumed by the motor. It represents the copper losses, due to Joule heating, in the stator and the rotor.

$f_{p_{RB}}$: It has relatively high value.

Once all the data is collected following formulas are to calculate the impedances:

$$Z_{RB} = \frac{V_{RB}}{I_{RB}} \quad (2.4)$$

$$Z_{RB} = R_{RB} + jX_{RB} \quad (2.5)$$

$$R_{RB} = \frac{P_{RB}}{3 \cdot I_{RB}^2} \quad (2.6)$$

$$R_{RB} = R_e + R_{r'} \Rightarrow R_{r'} = R_{RB} - R_e \quad (2.7)$$

$$X_{RB} = X_e + X_{r'} \quad (2.8)$$

There is no easy way to obtain the X_e and $X_{r'}$. For the motors less than 5.5 kW, following relation between reactances is acceptable [2].

$$X_e = X_{r'} = X_{RB}/2 \quad (2.9)$$

2.3.2 No-load test

As the name suggests, this test is performed without coupling any load to the motor shaft. And again, voltage (V_0), intensity (I_0), power (P_0) and f_p are measured using the same equipment. These readings are used to estimate the power losses in the motor, namely, mechanical, core and copper losses. The power (P_0) that is consumed by the motor is divided as following:

$$P_0 = P_m + P_H + P_{cu} \quad (2.10)$$

$$P_{cu} = 3 \cdot R_e \cdot I_0^2 \quad (2.11)$$

P_H : Core losses pertaining to the magnetizing branch

P_m : Mechanical losses

P_{cu} : Copper losses

This test is performed with various voltages. Each voltage delivers different power. With different values of voltage and power $V_0^2 - P_0$ graph can be traced. With the help of this graph the value of power can be determined when the voltage is 0. With the voltage being

0, core losses are also 0 since there is no current flowing through the magnetizing branch. So that value of power represents the mechanical losses.

Motor no. 1		Motor no. 2	
V_0 (V)	P_0 (W)	V_0 (V)	P_0 (W)
101,7	42,4	100	70,2
125	52,1	125	83,05
150	66,7	150	92,45
175,4	76,7	175	100,73
200,4	96,5	200	109,1
219	143,4	230	128
225,2	157,4	-	-

Table 2: No-load test results

Following the values listed in the table above, the values of P_m of both motors can be determined. The variation in voltages applied to both motors is due to the fact that the voltage of the grid is never constant.

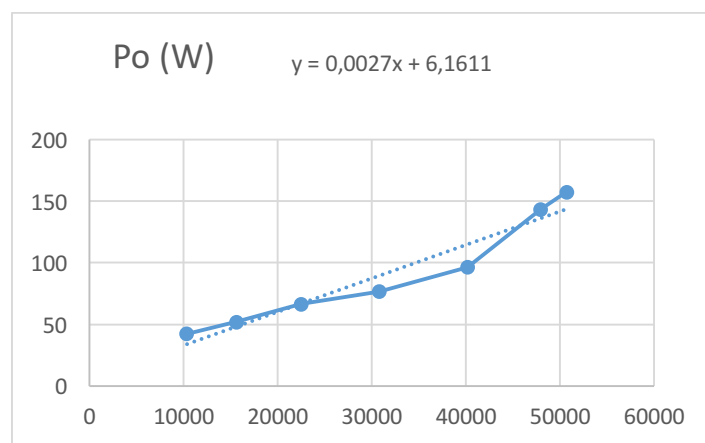
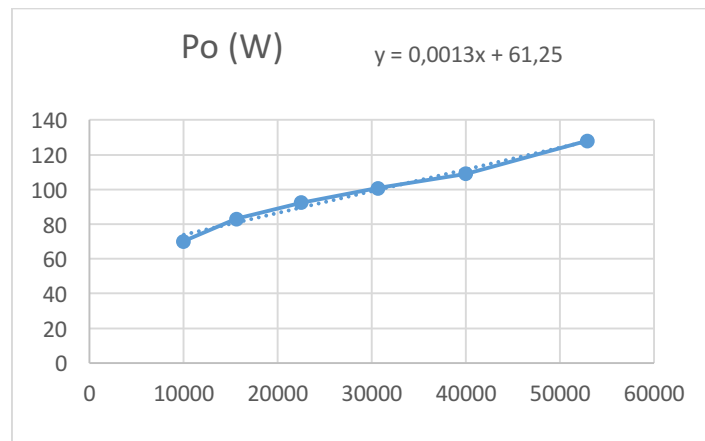

Figure 10: The V_0^2 - P_0 graph of motor no. 1

When the axis of abscissas is formed by square number and the axis of ordinates is formed by numbers that are not squared the graph is rectilinear. That's why, in the graph above, a trend line has been used to describe the relation between P_0 and V_0 . This trend line passes close to the real points.

The same strategy has been employed in the graph below. Both trend lines have their correspondent equations. To calculate the mechanical losses, the x is substituted with 0.

Figure 11: The Vo²-Po graph of motor no. 2

	Motor no. 1	Motor no. 2
P_m (W)	6	61

Table 3: Mechanical losses of motors

In the above table, the approximate value of mechanical losses is listed. Because of the small variation of speed in no-load and full-load conditions the P_m can be considered constant in every operational condition. There is only one parameter left to determine and that is X_m. To calculate the X_m of magnetizing branch following formulas are employed:

$$Z_0 = \frac{V_0}{I_0} \quad (2.12)$$

$$Z_0 = R_0 + jX_0 \quad (2.13)$$

$$X_0 = X_e + X_m \Rightarrow X_m = X_0 - X_e \quad (2.14)$$

The readings obtained from the test performed on the motors are display in the tables below.

No-load test		
	Motor no. 1	Motor no. 2
V₀ (V)	219	230
I₀ (A)	2.65	1.926
P₀ (W)	143.1	128
Q₀ (VAr)	994.7	756.4
S₀ (VA)	1005	767
fp	0.14	0.17

Blocked rotor test		
V_{RB} (V)	116.8	45.4
I_{RB} (A)	4.81	2.5
P_{RB} (W)	870	146.4
Q_{RB} (VAr)	430	131.3
S_{RB} (VA)	960	196.6
fp_{RB}	0.9	0.74

Table 4: No-load and blocked rotor tests' results

After applying the formulas mentioned earlier following values of impedances are obtained:

	Motor no. 1	Motor no. 2
Re (measured)	9.5	6.68
Z_{RB}	12.6 + j6.1	7.76 + j7.05
Z₀	6.7 + j47.45	11.72 + j67.94
Rr'	3.1/s	1.08/s
Xe = Xr'	j3.05	j3.525
Xm	j44.4	J64.42
Ze	9.5 + j3.05	6.68 + j3.525
Zr'	3.1/s + j3.05	1.08/s + j3.525

Table 5: Motors' parameters

At first, there seems to be no problem with the values of impedances of motor no. 1. But a close examination shows some contradiction in the values. For example, the copper losses in the no-load test are, at minimum:

$$P_{CU} = 3 \cdot 9.5 \cdot 2.65^2 = 200.14 \text{ W} \quad (2.15)$$

This value clearly surpasses the P_0 obtained during the tests. The P_0 must be, at least, equal to the core losses. The impedance calculated in no-load condition represents the sum of resistance and reactances of the stator and the magnetizing branch.

The measured resistance of the stator and the calculated one do not match with each other in both cases. Partly the working temperature is to blame. The temperature of the windings is subject to change with the temperature.

In order to validate these results and obtain the true value of every parameter, a Matlab simulation is employed. This simulation contains an exact equivalent circuit. The simulated circuit has a lot of blocks for measuring the signals.

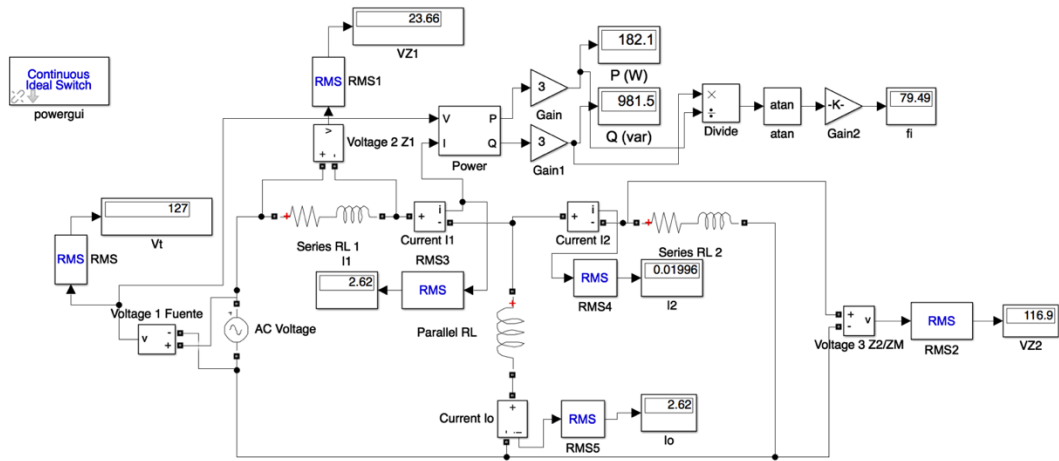

Figure 12: Simulation of exact equivalent circuit in no-load condition (motor no. 1)

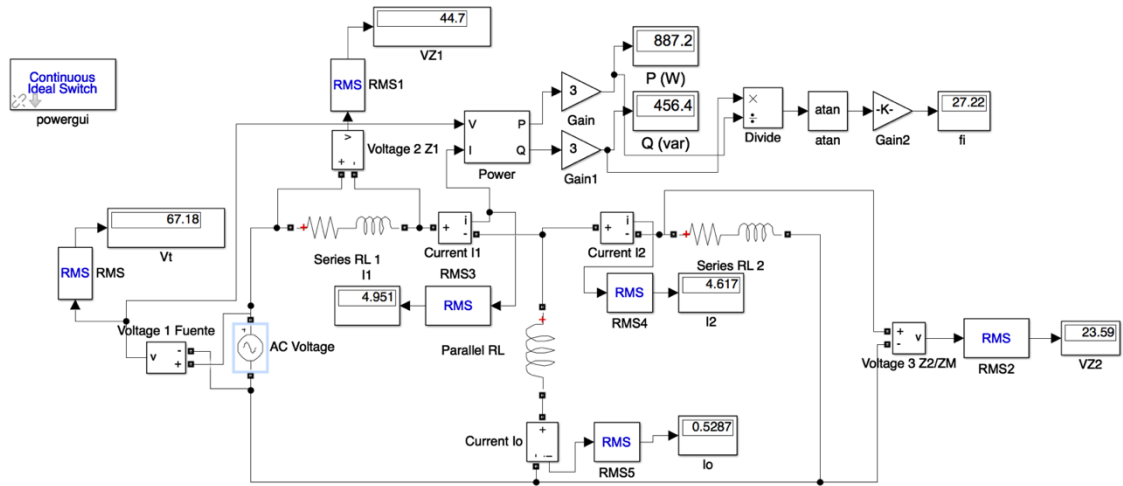

Figure 13: Simulation of exact equivalent circuit in blocked rotor condition (motor no. 1)

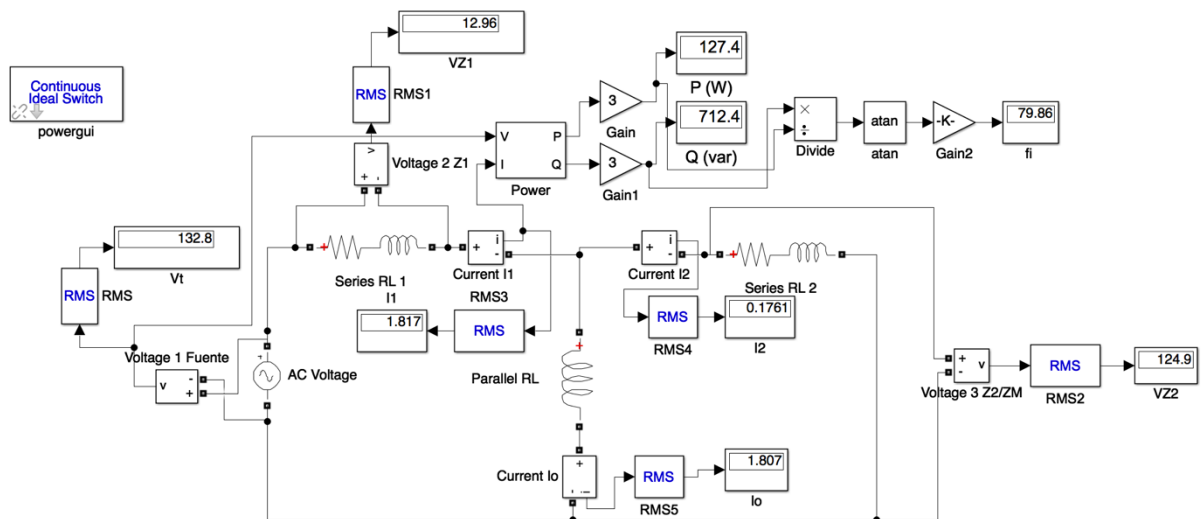

Figure 14: Simulation of exact equivalent circuit in no-load condition (motor no. 2)

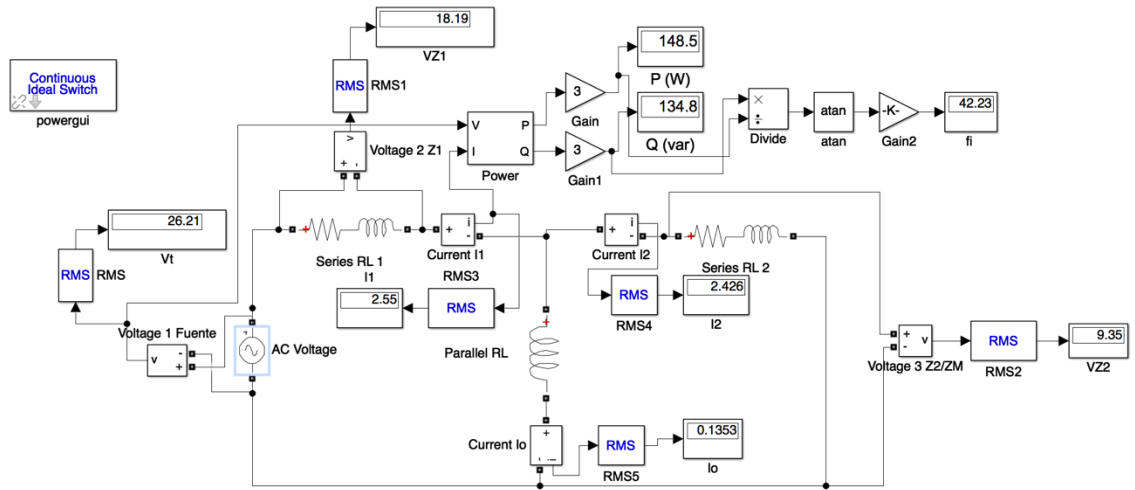

Figure 15: Simulation of exact equivalent circuit in blocked rotor condition (motor no. 2)

The no-load and the blocked rotor test will be simulated in this circuit with the corresponding voltages. For the no-load test the slip (s) will be close to 0 and for the blocked rotor test its value will be 1. The source voltage will be same as measured during tests.

As mentioned before, the resistances are unreliable with the varying temperature. But this is not the case for reactances. That’s why, the starting point of these simulations will be the R_m and leaked reactances of stator and rotor. These values will remain almost the same during the simulations.

At starting, the value of the resistance will be close to the one measured. From there, small changes will be made in the values of resistances until the readings are coherent. The consumed current should be very close to one measured.

After numerous tries following values are obtained. The simulated values are very close to their real-world counterpart.

No-load test				
	Motor no. 1		Motor no. 2	
	Measured	Simulated	Measured	Simulated
V_0 (V)	219	219	230	230
I_0 (A)	2.65	2.62	1.926	1.817
P_0 (W)	143.1	182.1	128	127.4
Q_0 (VAr)	994.7	981.5	756.4	712.4
S_0 (VA)	1005	998.25	767	723.7
fp	0.14	0.18	0.17	0.176

Blocked rotor test				
V_{RB} (V)	116.8	116.8	45.4	45.4
I_{RB} (A)	4.81	4.95	2.5	2.55
P_{RB} (W)	870	887.2	146.4	148.5
Q_{RB} (VAr)	430	456.4	131.3	134.8
S_{RB} (VA)	960	997.7	196.6	200.56
fp_{RB}	0.9	0.889	0.74	0.74

Table 6: Simulated no-load and blocked rotor test

	Motor no. 1		Motor no. 2	
	Calculated	Simulated	Calculated	Simulated
Re	9.5	8.5	6.68	6.2
Z_{RB}	$12.6 + j6.1$	$12.6 + j6.1$	$7.76 + j7.05$	$7.76 + j7.05$
Z_0	$6.7 + j47.45$	$8.73 + j47.68$	$11.72 + j67.94$	$12.86 + j71.94$
Rr'	3.1/s	4.1/s	1.08/s	1.56/s
$Xe = Xr'$	j3.05	3.05	j3.525	3.525
Xm	j44.4	J44.6	J64.42	J69.11
Ze	$9.5 + j3.05$	$8.5 + j3.05$	$6.68 + j3.525$	$6.2 + j3.525$
Zr'	$3.1/s + j3.05$	$4.1/s + j3.05$	$1.08/s + j3.525$	$1.56/s + j3.525$

Table 7: Simulated value of impedances

Now the values are in tune with each other with small variations. The only exception is the Re that does not match with resistance of Z_0 . Everything else, fits right in place.

These obtained values of impedances will be later used in the Matlab simulation to validate the results obtained in the tests. More specifically, they must be introduced in the block of motor so that it can simulate the motor's behaviour.

3 Laboratory Testing

As outlined in the introduction, in this part, the transient behaviour of the motors will be observed when there is a power cut. As mentioned before, the subject of these tests are two three-phase electric motors, namely, squirrel motor and wound rotor motor that will be tested in different operational conditions.

These tests are carried out in laboratory conditions. So there are some factors that are very different from what one can find in factories. For example, the room temperature is not excessively hot, there are no EMI (electromagnetic interference) sources nearby, there is no abrupt voltage changes in the network (due to high energy consumption elements connecting and disconnecting) and there are no external vibrations.

Said that, there are factors that can be controlled in the laboratory facility. Those factors are given below.

- 1) The operational conditions of motors can vary from one day to another, specially the load. So to simulate those conditions the tests will be done with different load. It is achieved by connecting a mechanical brake with variable resistant torque to the motor. The torque that applies this brake can be controlled from a dedicated switchboard.
- 2) Other than the load that varies, there is also two different type of connections possible, WYE and D. Most of the times, the nominal voltage of any given grid is fixed since every security element and other elements are installed for one particular nominal voltage. So, the connection of the motor remains the same as long as the motor operates in the same network.

In the laboratory, the nominal voltage is around 230 V. Sometimes, it's close to 225 V and other times it may exceed its nominal value, even though, it cannot be considered overvoltage. The subject motors operate, nominally, at 220 V. But the available voltage can be considered valid to perform the tests since a variation of up to 10% is admitted.

Now as discussed earlier, it is crystal clear that the connection in the junction box must be in D. However, for the sake of experimentation, there will be some testing done with WYE connection. The reason for that is to observe that how the outcome voltage will be when the motor is powered with a voltage lower than its nominal.

- 3) When people talk about power or electric power they refer to watts (W) or kilowatts

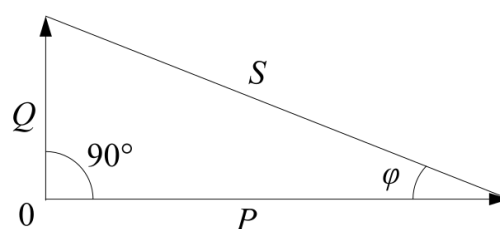

(kW) which is the there are two other

Figure 16: Power triangle

active power. But powers that are

consumed by a machine. These are reactive power (Q) and apparent power (S) with units VAR and VA respectively. The relation between three is shown below.

$$P = V \cdot I \cdot \cos\phi \quad (3.1)$$

$$Q = V \cdot I \cdot \sin\phi \quad (3.2)$$

$$S = V \cdot I \quad (3.3)$$

$$S = \sqrt{(P^2 + Q^2)} \quad (3.4)$$

ϕ = The power factor.

The active power is the responsible for creating the output power. However, the power consumed by the machine is the apparent power. The reactive power, in the case of motors, is inductive and it is used for creating the magnetic field. The power factor shows the relation between S and P , the smaller the angle smaller is the difference between both powers.

The bigger is reactive power bigger is the apparent power, even though, the active power remains the same. Which translates into bigger electric bill. That's why the capacitor banks are used to minimize the reactive power. It is achieved by injecting capacitive reactive power, which has an opposite direction than the inductive one, into the installation.

Very often, industrial installations have capacitor banks to minimize the reactive power consumption. Since, motors consume inductive reactive power, the capacitor banks lower the overall installation reactive power by contributing the capacitive reactive power. These can also be connected in WYE or D as per demand.

Considering all of the above, there are several possible combinations that will result in different operational conditions. That's why, tests will be done with different load conditions, i.e., no load, with mechanical brake coupled with the motor and with mechanical brake performing the torque of 2 N.m. in the opposite direction of the motion of motor.

Addition to that, the effects of capacitive compensation on the voltage generation will be observed. For that, test will be done when the capacitors are in WYE connection and D connection. And, as mentioned earlier, there will be experimentation with both types of possible connections.

3.1 Testing installation

The laboratory tests are carried out using following equipment:

- The motors
- Electric Cables – For these tests, electric wires with cross section area of 1.5 mm² are employed. This section is more than enough because the current that passes through them is small.
- A contactor - throughout the tests many power interruptions will be made. Disconnecting the wires directly from switchboard is very risky. This practice can lead

to serious injuries or death due to electrocution. To avoid this danger, a contactor will be employed. It is a switch that closes when it is connected 24 V (DC) current. With this amount of current there is no danger of electrocution.

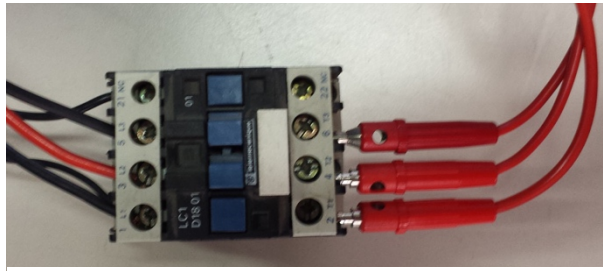

Figure 17: The contactor

- A capacitor bank – It constitutes of three capacitors of $10\ \mu\text{F}$. These can be connected in WYE or D configuration.

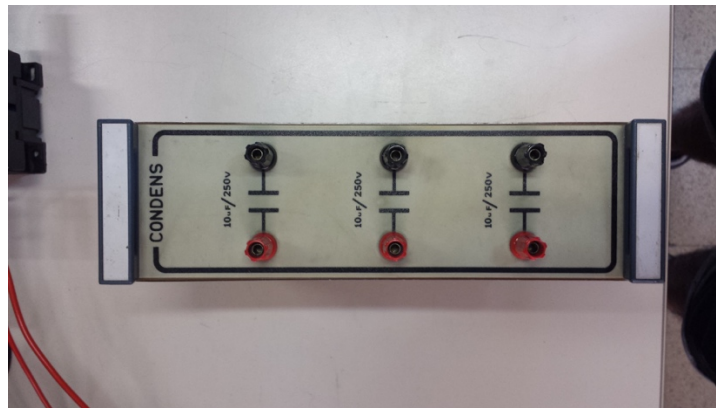

Figure 18: The capacitor bank

- An adjustable mechanical brake – This device is used to produce counter-torque.
- A tachometer – This device measures the revolutions per minute (rpm) of the motor. It connects on the opposite of the mechanical brake.
- An ammeter – This device is used to measure the amps (A). It will be connected in series with one of the phase of the motor. It is very simple and reliable element to monitor the current.

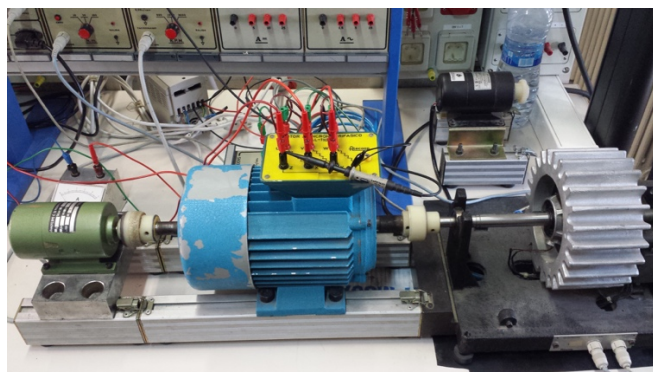

Figure 19: The tachometer (On far right), the mechanical brake (On far left) and the ammeter (Behind the tachometer)

The figure 19 represents the typical setup during the tests. When there is no need for load, the mechanical brake is simply detached from the motor. The ammeter is always connected to one of the phases. The probe of oscilloscope connects in one of the terminals of junction box.

- An analyser - This device is used to analyse an array of parameters of domestic or industrial grid. It can be employed in three-phase or single-phase network. It is also equipped with ports that can control relays and alarms if necessary. The power source of this device is one the phases.

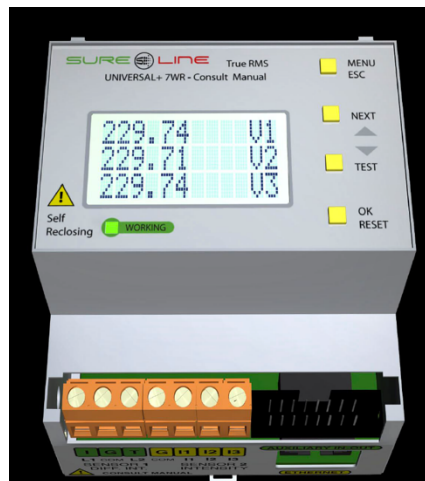

Figure 20: The analyser

The measurements are displayed on a small display mounted on the device. The most common ones are voltage and current. The analyser has many more functions and to take advantage of its full capabilities it is connected to a computer or a laptop.

The connection is via Ethernet. The readings and much more is visualized using a specialized software. This software is made by the same company as the analyser and is called Datawatch Pro. Once the software is installed, the analyser is simply connected to the computer using RJ45 cable and is configured as per instructions.

Every reading taken by the analyser can be visualized on a computer in a form of numerical values or graphs in real time. Further to these readings, the device also measures the power consumption. Every reading and measurement is stored locally on the computer which can be consulted on any later date.

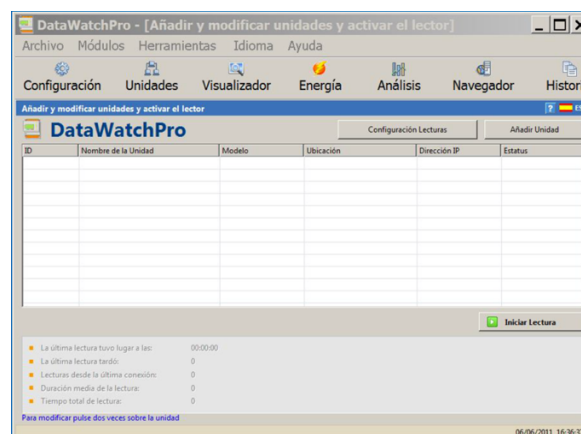

Figure 21: Datawatch Pro's main window

The analyser also measures harmonics present in the electric current. Not only that, it separates them according to their type. All in all, it is a great device to monitor the parameters and quality of electric current.



Figure 22: The analyser mounted in the protective case

The analyser is mounted in a plastic box in order to protect it from any physical abuse. It is connected between the grid and the machine, in this case a motor. The wires from both sides are connected in the terminal strip adjacent to the protective case.

As it can be seen, there are four points to connect the wires and one of them is for neutral wire. Inside the box there are three Rogowski coils responsible for measuring the current of every phase. The delicate wire connections of these coils are another reason to use a protective case.

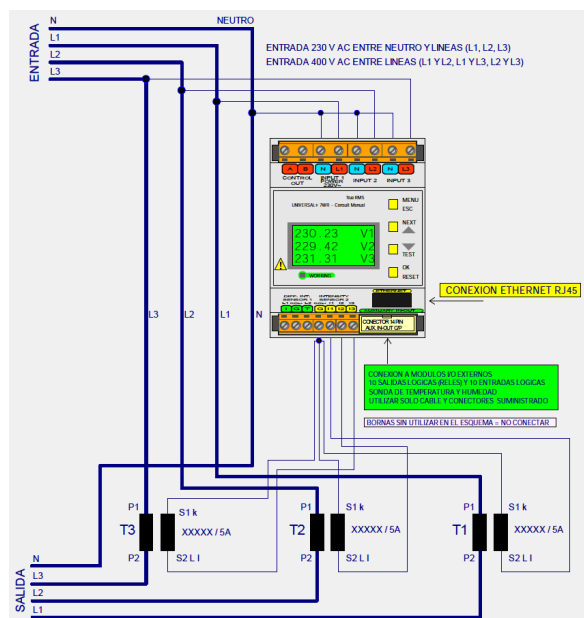

Figure 23: Connection diagram of the analyser

In this particular case, between the analyser and the motor there is a contactor as shown in the figure 24 . The analyser turns on automatically when connected to the network. Before commencing with any operation, the button of start reading is clicked on the first page.

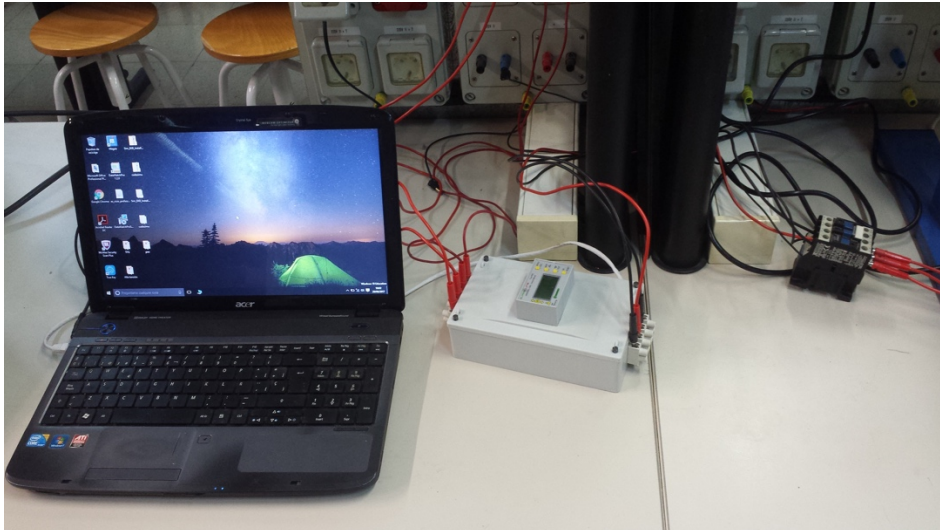

Figure 24: Circuit implementation of the analyser

After commencing with testing, there was a very apparent problem. The device was not registering the high current consumption, around 5 times the rated current, at the moment of starting. This phenomenon is very characteristic of the induction motors.

Furthermore, it was not registering or reading any transient waveform of the voltage after power shut down. The value of the voltage dropped to 0 after stopping the supply of electricity. This condition was consistent in every test performed with the analyser.

After inspection of every setting in the software, it was found that it was reading or taking samples every second (s). That was the smallest possible sample time available. That is why, the mentioned phenomena did not appear on screen because they happened in a matter of milliseconds (ms).

For the reason mentioned above, it is impossible to perceive the transient voltage using the analyser. To visualize and capture the transient waveform an oscilloscope will be used.

- An oscilloscope – This apparatus will be used to observe the transient waveform of the voltage.



Figure 25: The Oscilloscope

3.1.1 Electric circuit

As it has been explained before, the capacitor bank and the motor will be connected with each other electrically in different forms. There are various possible configurations because sometimes the capacitors will not be connected and other times they will be connected in the WYE or D connection. All the six possible combinations are listed below.

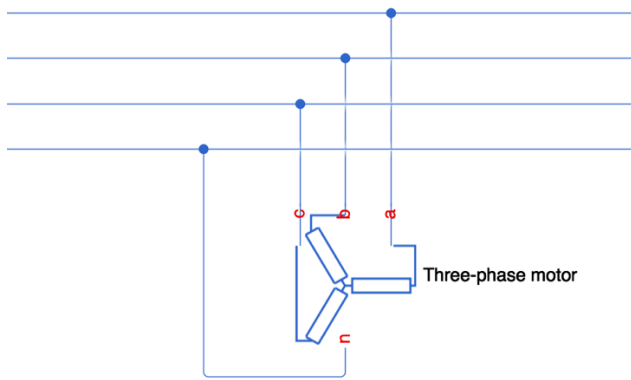

Figure 27: The motor connected in WYE

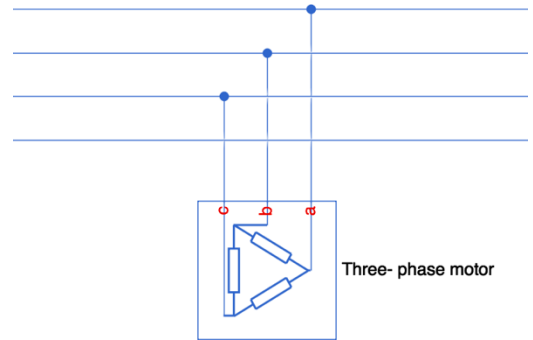

Figure 26: The motor connected in D

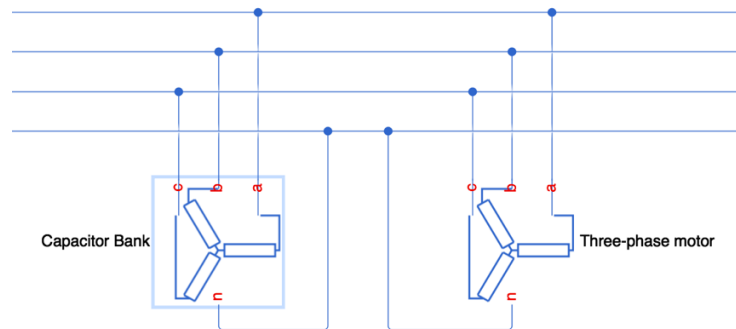

Figure 28: Motor and capacitor connected in WYE

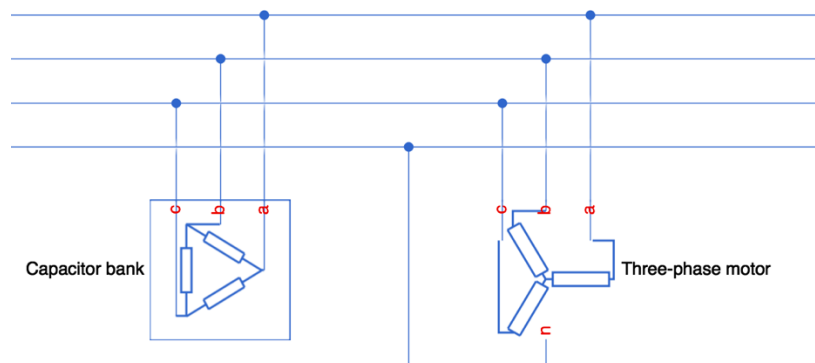

Figure 29: Motor connected in WYE and capacitor bank in D

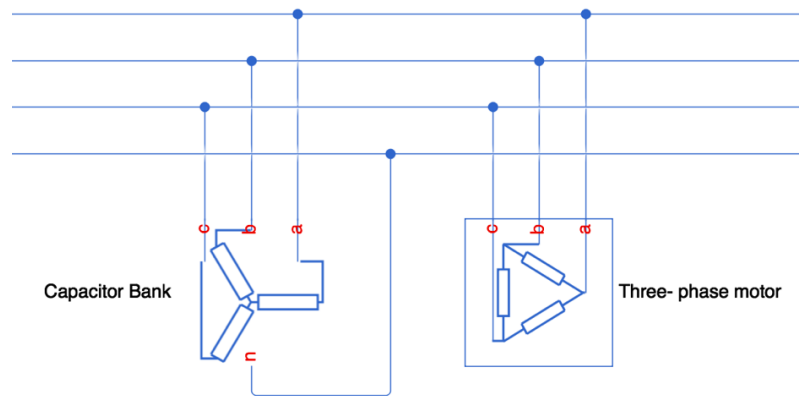

Figure 30: Motor connected in D and capacitor bank in WYE

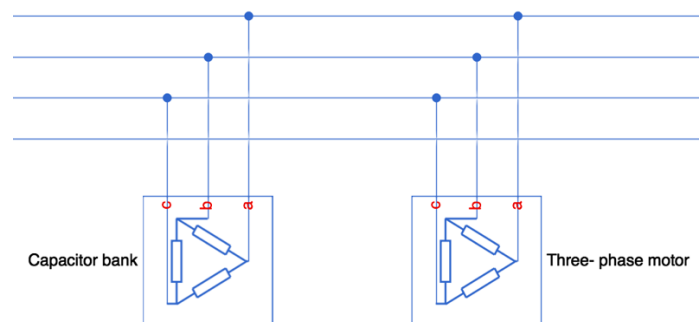

Figure 31: Motor and capacitor connected in D

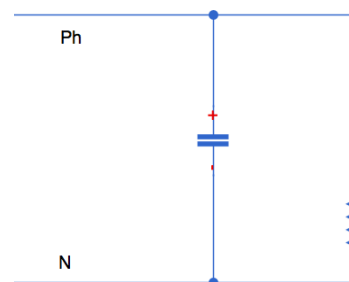

Figure 32: Phase-neutral connection of the capacitor and the motor

All these combinations offer different equivalent impedance that is perceived by the electric grid. The first step towards finding the equivalent impedance circuit is to know the impedance of motor during every operation. There are various points to keep in mind:

- The rotor resistance varies with the load (Rr'/s). Slip can be calculated by knowing the speed in every case and synchronous speed of the motor (n_s).

$$s = \frac{ns - nr}{ns} \quad (3.5)$$

- When there is no load connected, following the approximant equivalent circuit, Z_e and X_m are summed up to calculate the impedance of the motor.
- When there is a load connected, following the approximant equivalent circuit, Z_e and Zr' are summed up to calculate the impedance of the motor.

- If the capacitor bank is not connected to the grid, then the equivalent impedance will belong to one of the cases mentioned above.
- If the capacitor bank is connected in WYE, then impedances of the motor and the capacitor bank are summed as in any other parallel RLC circuit.

$$Z_t = \frac{Z_m * Z_c}{Z_m + Z_c} \quad (3.6)$$

If not, then the impedance of capacitor bank in D must be converted into its equivalent impedance in WYE using the following formula.

$$Z_{D-Y} = \frac{Z_c^2}{3 * Z_c} \quad (3.7)$$

Once the conversion is completed, the equivalent impedance is calculated according to the formula 3.6.

The impedance has two parts, one real and one imaginary. If the imaginary part is bigger than 0 then the circuit is inductive. If the imaginary part is smaller than 0 then the circuit is capacitive. Theoretically speaking, the more capacitive is circuit, the larger its impact would be on the transient voltage.

Addition to the different combinations mentioned above, the mechanical brake is also connected to the motor in some cases. In total, 34 test are carried out with different combinations of capacitor bank, motor and mechanical brake. These combinations are listed below with their correspondent test number.

Test no.	Motor	MC	CB	Brake (N.m)
1	1	WYE	No	No
2	1	WYE	No	0
3	1	WYE	No	2
4	1	WYE	WYE	No
5	1	WYE	D	No
6	1	WYE	WYE	0
7	1	WYE	D	0
8	1	WYE	WYE	2
9	1	WYE	D	2
10	1	D	WYE	No
11	1	D	D	No
12	1	D	WYE	0
13	1	D	D	0
14	1	D	WYE	2
15	1	D	D	2
16	1	D	D	4,2
17	2	D	No	No
18	2	D	No	0
19	2	D	No	2
20	2	D	WYE	No

21	2	D	D	No
22	2	D	WYE	0
23	2	D	D	0
24	2	D	WYE	2
25	2	D	D	2
26	2	WYE	No	No
27	2	WYE	No	0
28	2	WYE	No	2
29	2	WYE	WYE	No
30	2	WYE	D	No
31	2	WYE	WYE	0
32	2	WYE	D	0
33	2	WYE	WYE	2
34	2	WYE	D	2

Table 8: Different test conditions

MC: It stands for motor connection which can be in WYE or D.

CB: It stands for capacitor bank which can be connected or not to the motor. It can be connected in D or WYE.

Brake: If it says No then the mechanical brake is not connected to the motor. If the value is 0 then it is connected to the motor but it is not performing any counter-torque. If the value is greater than 0 then it represents the counter-torque it is producing on the motor.

The equivalent impedance has been calculated for every test done in the laboratory. The list of these impedances can be found below. For the calculation of these equivalent impedances, the factors above mentioned are taken into consideration.

Test no.	Equivalent impedance
1	8,5+47,65i
2	90,5+6,1i
3	22,17+6,1i
4	11,74+55,67i
5	27,43+82,51i
6	86,78-18,93i
7	56,01-44,21i
8	50,19-1,74i
9	44,76-15,68i
10	11,74+55,67i
11	27,43+82,50i
12	116,09-42,68i
13	56,01-44,21i
14	86,78-18,93i
15	44,76-15,68i
16	15,21-29,01i
17	6,2+72,635i
18	45,2+7,05i

19	21,8+7,05i
20	10,40+93,85i
21	60,25+219,11i
22	46,29+0,49i
23	42,92-12,032i
24	25,89+5,14i
25	26,89+0,78i
26	6,2+72,635i
27	22,91+7,05i
28	12,88+7,05i
29	10,40+93,85i
30	60,25+219,11i
31	15,86+6,43i
32	24,96+1,78i
33	13,45+6,651i
34	13,96+5,81i

Table 9: Table of equivalent impedances

These impedances will be cross checked with the cases in which overvoltage is produced. This way, it can be proved if the equivalent impedance has any impact on the transient voltage or not.

3.2 Formula-based analysis

A circuit in which a capacitor, an inductor and a resistance is connected to each other is known as a second order system. It is named like this because it has two energy storing device, i.e., the capacitor and the inductor. It is also known as RLC circuit. Essentially, the RLC circuit is the same as the capacitor and the motor connected in parallel in phase-neutral configuration as illustrated in Figure 25.

When the power is cut off from this circuit, it produces transient voltage in similar fashion as the induction motors. This phenomenon is dubbed as transient response of second order system. This transient response can be studied with formulas. Theoretically, the same method can be employed to study the transient waveform produced by the motor.

$$v_c(t) = 2 * |A_1| * e^{-\alpha t} * \cos(\omega_d t + \angle A_1), \quad t > 0 \quad (3.8)$$

The formula 3.8 describes the waveform produced by the RLC circuit. The negative exponent ensures that the end value is 0. The speed with which this equation equates to 0 depends on α and t . The bigger is α the faster it equates to 0. The parameters of this formula for a parallel RLC circuit are the following:

$$\alpha = \frac{R}{2L} \quad (3.9)$$

$$\omega_0^2 = \frac{1}{LC} \quad (3.10)$$

$$\omega_d = \sqrt{\alpha^2 + \omega_0^2} \quad (3.11)$$

$$p_1, p_2 = -\alpha \pm w_d i \quad (3.12)$$

The R, L and C are, respectively, resistance, inductance of inductor and capacitance of capacitor. The value of A1, which is a complex number, is obtained by solving the following matrix operation.

$$\begin{bmatrix} 1 & 1 \\ p_1 & p_2 \end{bmatrix} \times \begin{bmatrix} A_1 \\ A_2 \end{bmatrix} = \begin{bmatrix} y(0^+) \\ y'(0^+) \end{bmatrix} \quad (3.13)$$

$$y(0^+) = v_c(0^+) = v_c(0^-) = V \quad (3.14)$$

$$y'(0^+) = v_c'(0^+) = 0 \quad (3.15)$$

A2 is complex conjugate of A1. It means that the magnitude of real part and imaginary part of A2 is same but the value of complex component of A2 is opposite in sign. The V is the voltage of the grid to which the circuit is connected.

This formula-based analysis can be used to validate the results of real-world tests. However, in the case of induction motors, the phenomenon of overvoltage occurs at $t = 0$. This formula is useful when the time is greater than 0. Also the product of A1 and 2 is equal to the voltage supplied by the grid. So, the maximum value obtained from this formula will never exceed the value of network's voltage.

3.2.1 Dynamic analysis

The next step in formula-based analysis of motor is to analyse its behaviour during acceleration and deceleration. Since the transient voltage is produced during the deceleration. This analysis commences with the following formula:

$$T - T_r = J \frac{d\omega}{dt} \quad (3.16)$$

Where:

T: Electromagnetic torque of motor (Nm)

T_r : Counter-torque of the load (Nm)

J: Inertia (kg.m^2)

ω : Rotational speed of motor (rad/s)

After the process of integration of the given equation, following equation is obtained:

$$\tau_{mec} = \frac{J\omega}{T_{max}} \quad (3.17)$$

This equation gives the electro-mechanic time constant, also called tau, that determines the time that a rotor with J inertia take to accelerate to the synchronous speed (ω) under the influence of the maximum torque (T_{max})

4 Test's results

Following everything explained up until now 34 test are performed. The results of these tests are catalogued in the table below. The parameters obtained from the tests are motor's speed, consumed current, peak value of transient waveform and the duration of the said waveform. The image of transient voltage waveform produced in every test can be found on the far right of the table.



The transient waveform is observed and analysed on the oscilloscope. The parameters such as peak value of transient waveform and its duration are measured directly on the oscilloscope.

The apparatus does not have the ability to tell if there is any overvoltage. However, it is relatively easy to visually tell the presence of an overvoltage.

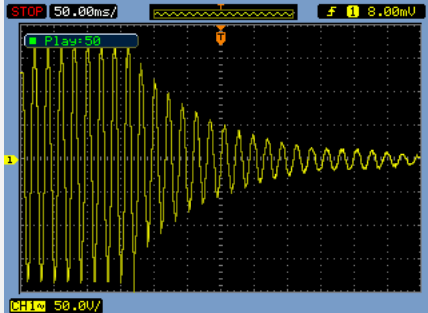
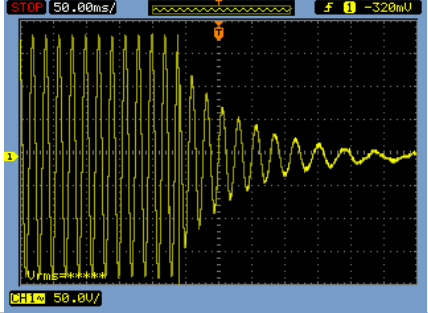
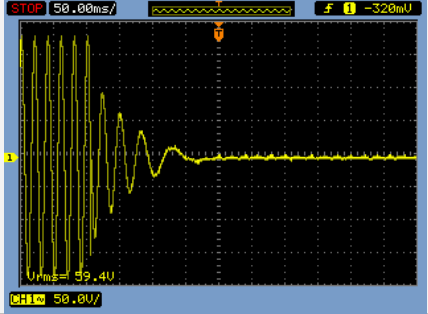
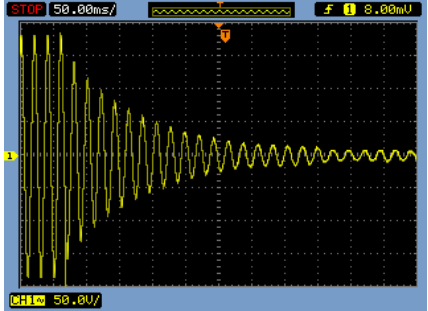
The peak value of the transient waveform is compared with the peak value of voltage that is being supplied by the grid. If the value of latter is higher then there is no overvoltage. For the sake of this comparison, the peak value of grid's voltage is also listed in the table.

Test no.	Motor	V_p (V)	RPM	I (A)	V_m (V)	t (ms)	Overvoltage	Transient waveform
1	1	179,65	1450	0,66	124	482	No	
2	1	179,65	1425	1,53	122	334	No	
3	1	179,65	1050	3,85	90	158	No	
4	1	179,65	1450	0,3	172	940	No	

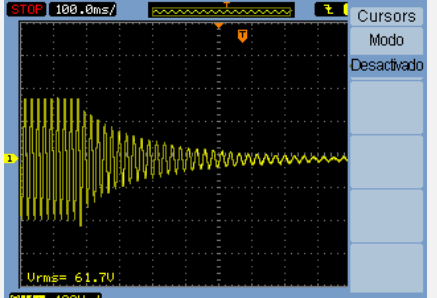
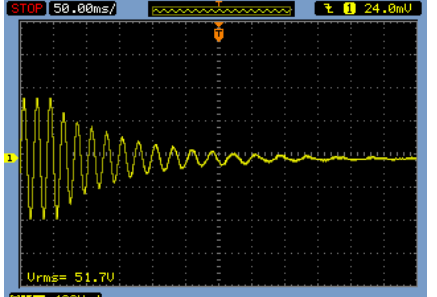

5	1	179,65	1450	0,63	228	1060	Yes	
6	1	179,65	1425	0,5	148	434	No	
7	1	179,65	1425	0,7	200	432	Yes	
8	1	179,65	1350	1,25	144	216	No	

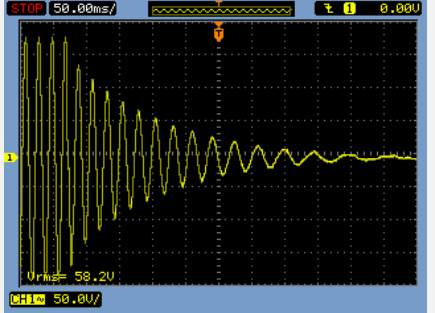
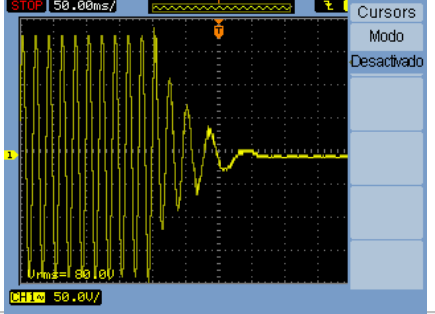
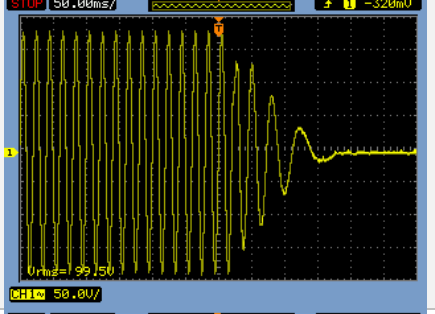
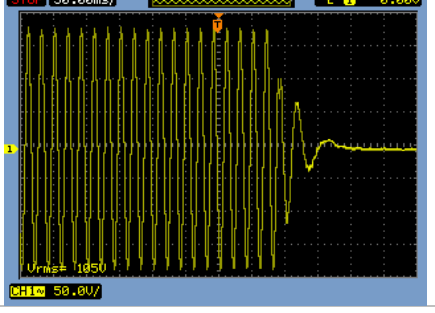
9	1	179,65	1350	1,35	148	170	No	
10	1	311,17	1450	2,6	148	519	No	
11	1	311,17	1450	1,7	140	990	No	
12	1	311,17	1450	2,5	136	474	No	

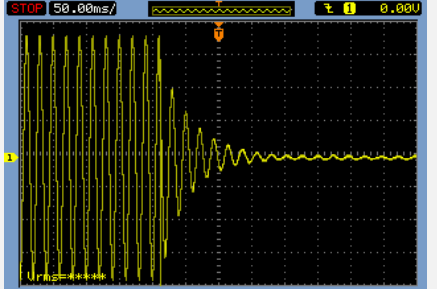
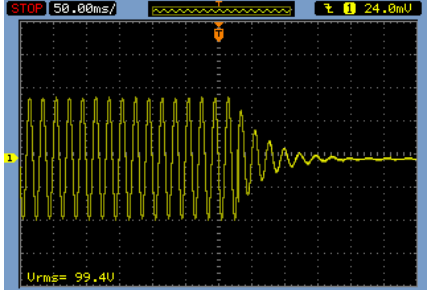
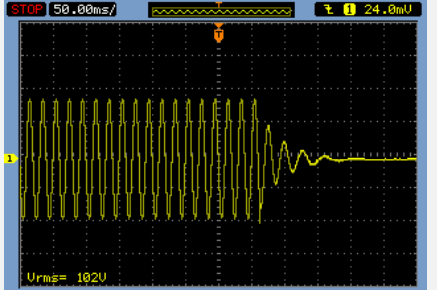
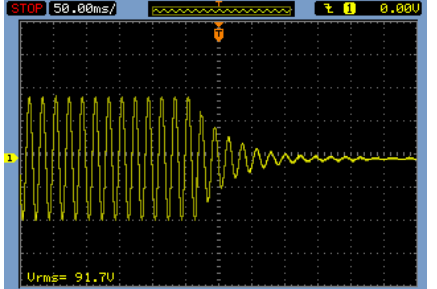
13	1	311,17	1425	1,7	140	508	No	
14	1	311,17	1425	2,82	176	162	No	
15	1	311,17	1350	2,2	134	252	No	
16	1	311,17	1400	3,5	94	112	No	

17	2	311,17	1450	2	150	180	No	
18	2	311,17	1440	2,2	144	164	No	
19	2	311,17	1350	2,5	148	144	No	
20	2	311,17	1450	1,65	128	200	No	

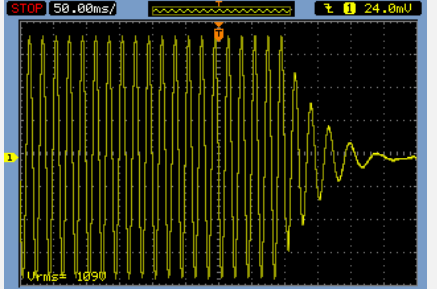
21	2	311,17	1450	0,85	164	400	No	
22	2	311,17	1440	1,65	180	216	No	
23	2	311,17	1440	0,9	156	286	No	
24	2	311,17	1375	2,2	168	134	No	

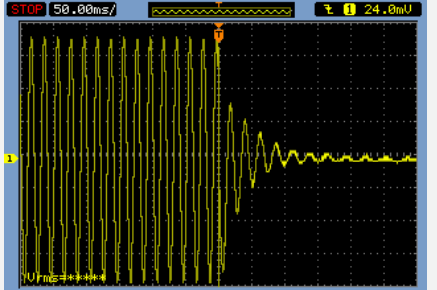
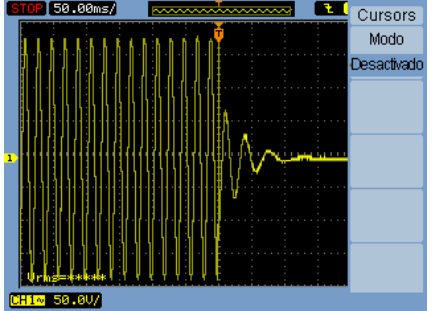
25	2	311,17	1375	1,55	138	190	No	
26	2	179,65	1440	0,6	144	300	No	
27	2	179,65	1360	0,75	168	150	No	
28	2	179,65	1150	1,6	68	138	No	

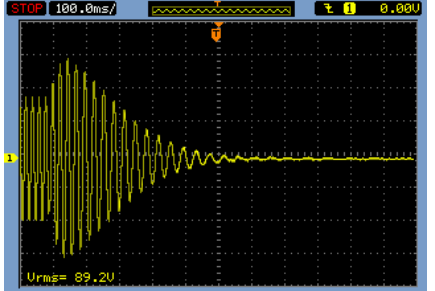
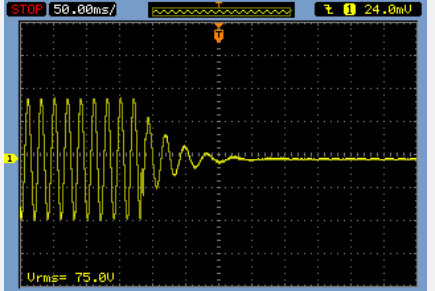
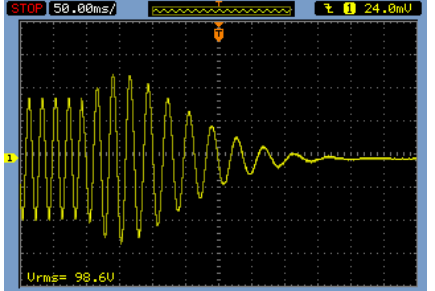
29	2	179,65	1440	0,3	158	552	No	
30	2	179,65	1440	0,7	296	600	Yes	
31	2	179,65	1240	1,2	112	175	No	
32	2	179,65	1360	0,82	248	434	Yes	

33	2	179,65	1150	1,4	132	156	No	
34	2	179,65	1120	1,55	208	158	Yes	

Table 10: Table of results of laboratory tests

Motor: It tells the number of the motor being tested.

Vp: It is the peak value of voltage. It represents the highest value of the sinusoidal waveform of the voltage. It is smaller in WYE connection.

RPM: It represents the speed of the motor in every case.

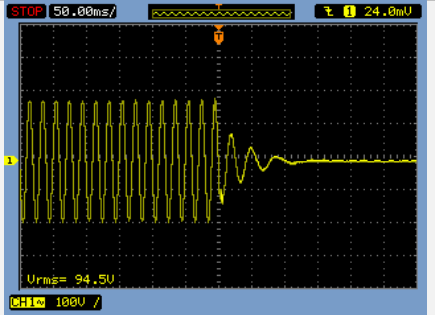
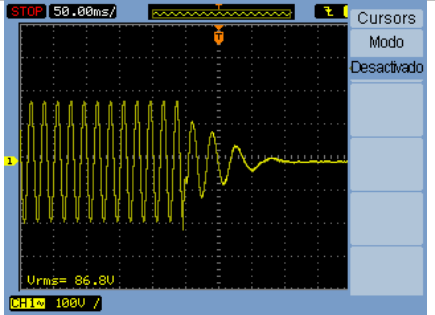
I: It represents the current consumed by the motor.

Vm: It represents the peak value of the voltage produced by the motor after shutting down the power.

t: It represents the duration of the voltage waveform produced by the motors.

Overvoltage: If it says No then there is no overvoltage produced. If it says Yes then there has been an overvoltage.

4.1 Results' analysis

The overvoltage is observed in five different cases, two for motor 1 and three for motor 2. In every case, the capacitor bank is connected parallel to the motor. And in every case, the capacitor bank is connected in D and the motor is connected in WYE.

In the motor no. 1, the overvoltage is produced when it is not connected to any load and it is connected to the mechanical brake. In the latter case, there was no counter-torque performed on the motor. Apart from the overvoltage, the capacitor bank also contributes in extending the transient time regardless of its type of connection.

Even if there is no overvoltage, the V_m is greater in the cases where CB is connected compared to those in which there is no capacitive compensation. The effects of CB are mitigated when the mechanical brake is connected

In the motor no. 2, the overvoltage is produced in three different instances, in no-load condition, when it is connected to the MB without any counter-torque and when it is connected to the MB with the counter-torque of 2 N.m.

When the motors are connected in D connection, the resulting V_m is usually higher when the CB is connected in WYE configuration. And when the motors are in WYE connection the V_m is always higher when the CB is in D connection.

The load connected to the motor always mitigates the transient voltage. Both in its peak value and the transient time. If there is counter-torque the effects of load are aggravated. But there seems to be some exceptions in this trend.

As for equivalent impedance, there seems to be no relation between the value of impedance and the voltage produced. The test no. 7 is the only capacitive circuit in which the overvoltage is observed. In the rest of the cases, the circuits are inductive.

In conclusion, the motors do produce an overvoltage when they are connected to a capacitor bank. For that to happen, the CB must be connected to the higher voltage than the motor. Even if there is no overvoltage, the capacitive compensation leads to higher V_m than the cases without any CB connected.

5 Matlab simulation

As outlined in the introduction, the data collected from tests is validated using the simulation of the phenomenon. For the simulation, Matlab is used. The circuit used in the laboratory testing is reproduced in this software.

It has an extensive library of elements to choose from. Every device, machine and apparatus used in the laboratory is available in Matlab in the form of blocks. These blocks have several parameters that one must know in order to make it functional in the desirable way.

Once the blocks have been updated with the correct information, they must be interconnected with each other in the right way. The simulation would not work if any essential information is not introduced; it would give an error.

The simulation circuits for both the motors are same. The only things that change are the parameters. Now, following the introduction, the cases that present overvoltage will be simulated. The waveforms of voltage of the simulation will be compared to the ones obtained during the tests.

The blocks that are used in the simulations are listed below.

- The asynchronous machine (SI units): This block represents the three-phase motor. It can be used as squirrel cage motor or wound rotor motor. It has three inputs to connect the wires. It also has an input to introduce the counter-torque (T_m) which is not used. Because, if the counter-torque is established, it keeps rotating the motor even if there is a power cut.

It has one output port which can be configured to show a variety of parameters. For the sake of the testing, the rotor speed is selected because the data of motor's speed is available from the laboratory test.

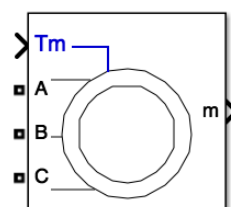

Figure 33: Asynchronous Machine (SI units)

As for the parameters, basic motor information is introduced, such as nominal power, rated voltage and frequency. The motor's resistances are also introduced in the parameters section. Since the rotor resistance referred to the stator (R_r'/s) depends on speed it is adjusted with every change in the speed.

Another than resistances, leaked reactances are also added in the form of induction (H). The load that is dragged by the motor is controlled by friction factor. Actually, the

friction factor directly affects the speed, the higher the friction factor the lower the speed. Since the load affects the speed, by controlling the speed the effect of load on the motor is simulated.

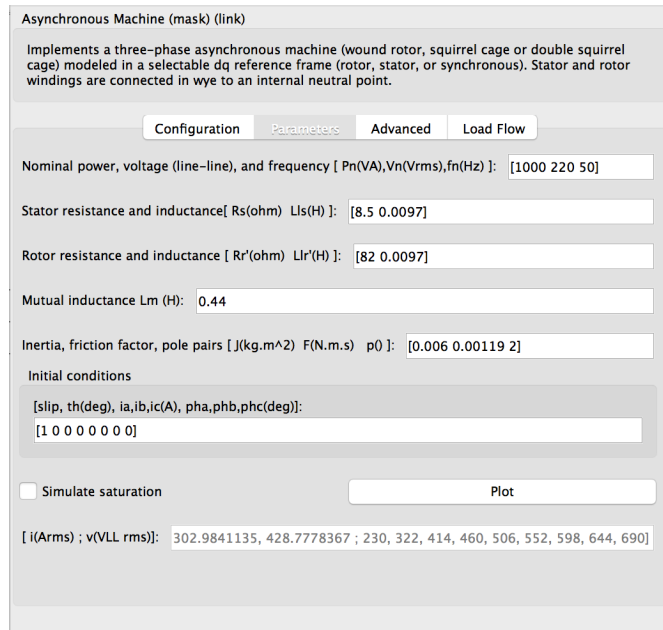

Figure 34: Asynchronous machine's parameters window

Other parameters, such as, mutual induction and inertia cannot be found in the technical specifications nor can be calculated. According to the Jesús Fraile Mora in his book Máquinas eléctricas [2], the value of the inertia can be between 0.0015 and 0.0035 J (kg.m²). Below is a table containing the values of inertia for different powers.

kW	J (kg.m ²)
0.55	0.0015
0.75	0.0018
1.1	0.0025
1.5	0.0035

Table 11: Relation between power and inertia (Source: Máquinas eléctricas. Jesús Fraile Mora [2])

The values presented in the table serve as guidance. As for the mutual induction, it is a matter of trial and error. So, in order to get the desirable results, many combinations of mutual induction and inertia are tried. Once the result match with, or comes close to, one of the results obtained in the tests, the two parameters are determined. The selected values of these two parameters are listed below.

	Squirrel cage motor	Wound rotor motor
Mutual induction (H)	0.46	0.5
Inertia (J (kg.m ²))	0.003	0.003

Table 12: Values of mutual induction and inertia of simulated motors

Now for simulating different cases on the same motor the only things that require alteration are the friction factor and the rotor resistance. The rest of the parameters remain unchanged.

The only limitation of this block of motor is that it is preconfigured to run with WYE connection. But, this restriction does not affect the simulations in any way because every overvoltage case in tests was with motor in WYE connection.

- Three-phase programmable voltage source: Without this block the simulation would not work. The two parameters that must be added to this block are line to line voltage and the frequency that are 220 V and 50 Hz.

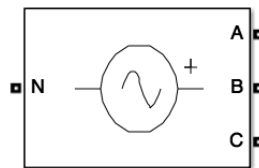

Figure 35: Three-phase programmable voltage source

- Three-phase load: This block represents the capacitor bank. The type of connection must be selected; in this case, it is delta (D) connection. And the power produced by the capacitors must be introduced.

$$Q_C = 3 \cdot (V_L^2) \cdot 2 \cdot \pi \cdot 50 \cdot C \quad (4.1)$$

By applying this formula, the capacitive reactive power of the capacitors is calculated. Since the C is 10 μ F, the Q_C is 456.16 VAR.

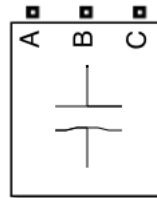

Figure 36: Three-phase load

- Three-phase breaker: This block is used to interrupt the power supply to the motor. It is equivalent of the contactor employed in the testing. It cuts off the power supply after 3 seconds.

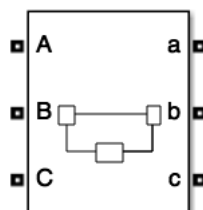

Figure 37: Three-phase breaker

- Three-phase V-I measurement: This block has an output ports that shows the voltage and current of every single phase.

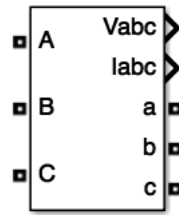

Figure 38: Three-phase V-I measurement

- Voltage reader: This block is used to measure the voltage of a single phase. The reading of this block is used for the comparisons of the waveforms.



Figure 39: Voltage measurement

- Scopes: These blocks illustrate the measurements of the blocks they are connected to.

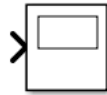

Figure 40: Scope

- Step: This block is used to introduce a constant value in any block. It is connected to the input port of the counter-torque (T_m) with value 0. If the T_m is left unconnected the simulation would not work.



Figure 41: Step

- Gain: This block is used to multiply the signal with the established number. The output signal of the motor gives the speed in rad/s. The step block is used to convert rad/s into rpm.

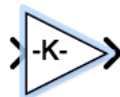

Figure 42: Gain

- Ground: This block is used to ground any electric circuit. It is an essential element in power grids that can save lives in the case of short circuits.



Figure 43: Ground

- Powergui: The majority of the above mentioned blocks fall under the category of Simscape Power System Specialized Technology models. When the blocks from this category are used, the powergui block must be included in the simulation.

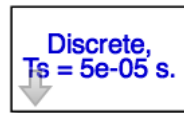

Figure 44: Powergui

The final circuit after connecting all the blocks looks as following.

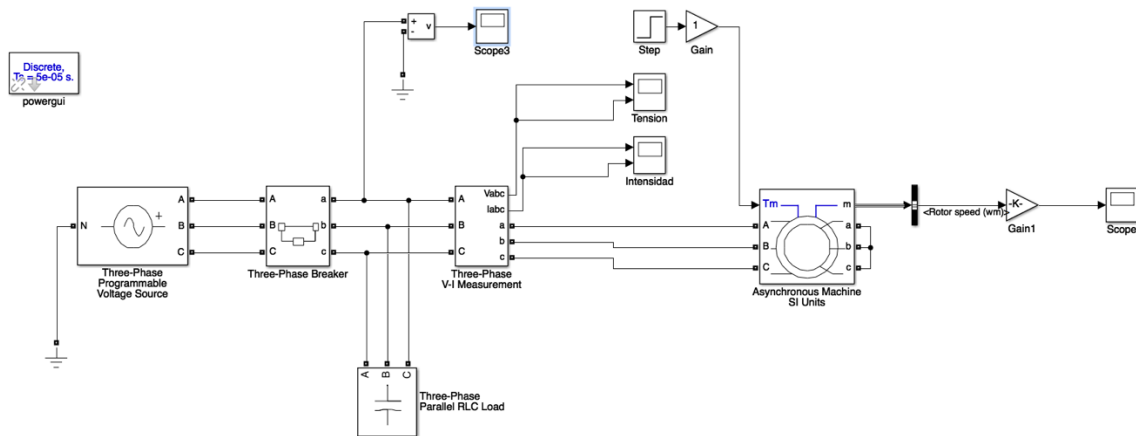
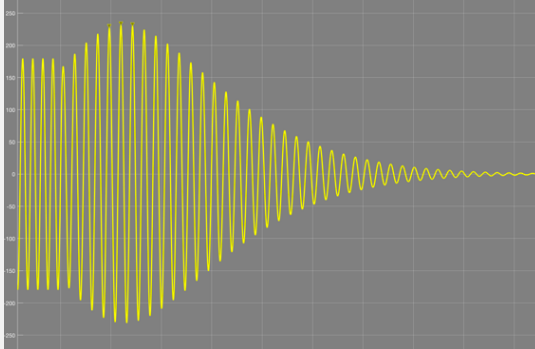
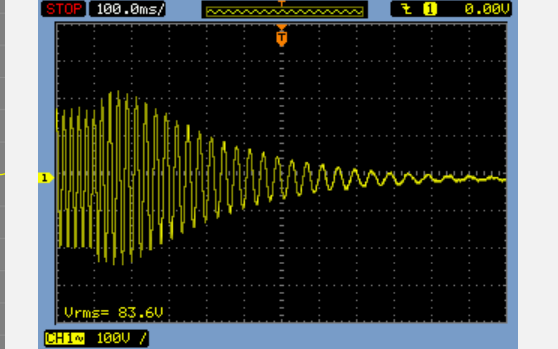
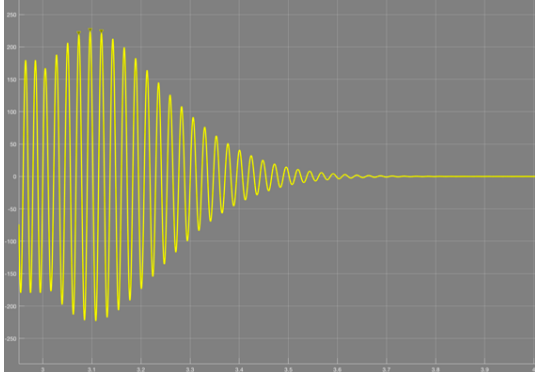
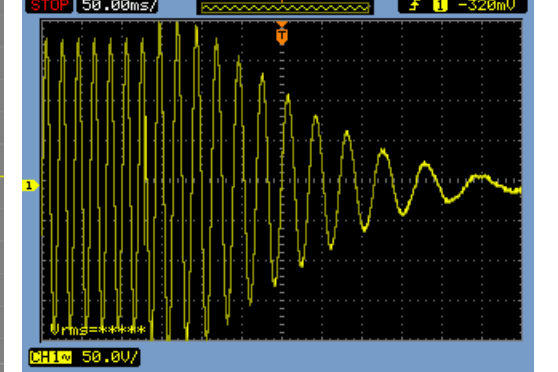
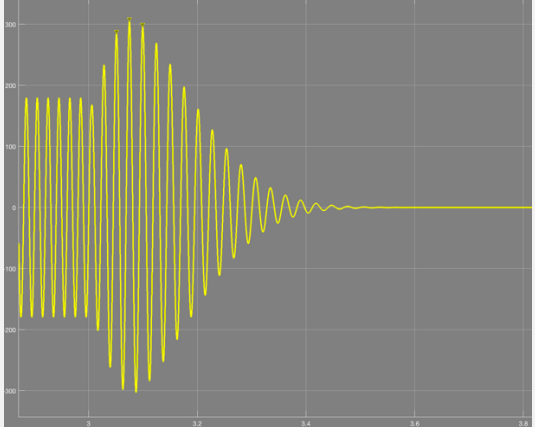
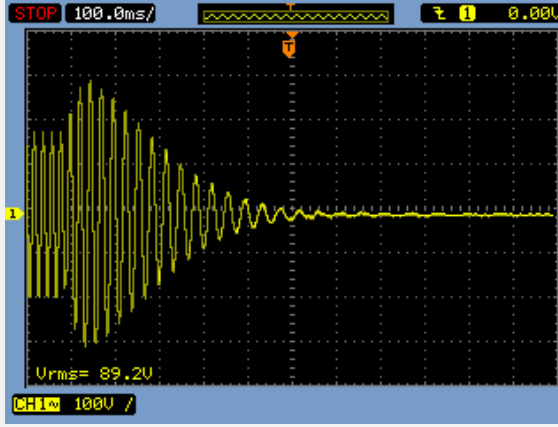

Figure 45: Simulation circuit

5.1 Simulation results

As mentioned earlier, five different simulations are executed, two for motor no.1 (squirrel cage motor) and three for motor no.2 (wound rotor motor). In order to do a visual comparison between the results from testing and simulation, the measurements from two are placed down side by side in the following table. Alongside two measurements, the corresponding test no. can be found.

Test no.	Simulation result	Test result
5	 <p data-bbox="355 633 750 656">Figure 46: Test no. 5 - Simulation result</p>	 <p data-bbox="933 633 1300 656">Figure 47: Test no. 5 - Lab test result</p>
7	 <p data-bbox="355 1115 750 1137">Figure 48: Test no. 7 - Simulation result</p>	 <p data-bbox="933 1115 1300 1137">Figure 49: Test no. 7 - Lab test result</p>
30	 <p data-bbox="355 1641 750 1664">Figure 50: Test no. 30 - Simulation result</p>	 <p data-bbox="933 1641 1300 1664">Figure 51: Test no. 30 - Lab test result</p>

32	 <p>Figure 52: Test no. 32 - Simulation result</p>	 <p>Figure 53: Test no. 32 - Lab test result</p>
34	 <p>Figure 54: Test no. 34 - Simulation result</p>	 <p>Figure 55: Test no. 34 - Lab test result</p>

Table 13: Simulation's waveforms

5.1.1 Simulation results' analysis

The first two readings, i.e., test no. 5 and 7, belong to motor no.1. And the other three readings, i.e., tests no. 30, 32 and 34 belong to the motor no. 2. As it can be observed, the simulation results are very close to the ones of laboratory testing. The comparisons of the measurements can be found below.

Test no.		Test	Simulation
5	Vp (V)	228	227
	t (ms)	1060	800
	I (A)	0.63	1.2
7	Vp (V)	200	218
	t (ms)	432	500
	I (A)	0.7	1.2
30	Vp (V)	296	295
	t (ms)	600	550
	I (A)	0.7	1.1
32	Vp (V)	248	160
	t (ms)	500	300
	I (A)	0.82	1.4

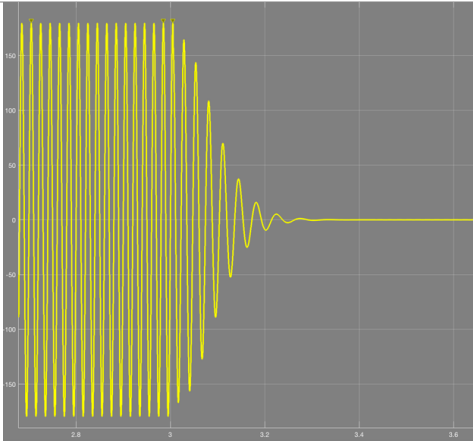
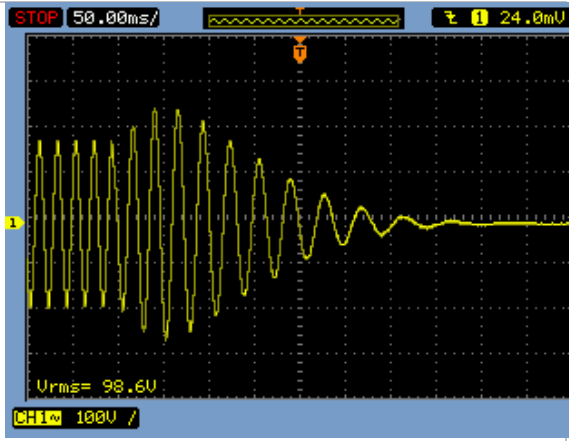
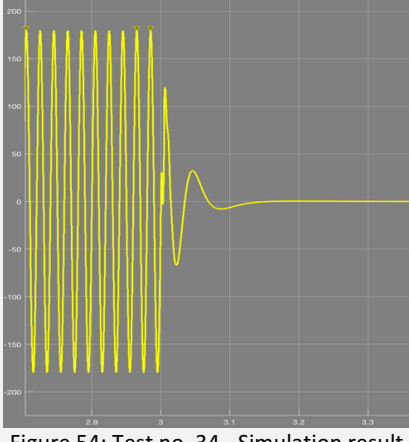
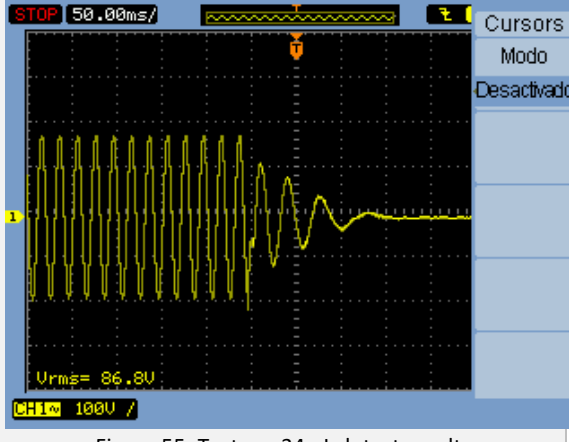
34	V _p (V)	208	120
	t (ms)	160	130
	I (A)	1.55	5.85

Table 14: Comparison of simulation results and test results

The simulated transient voltage shown in the above images is single-phase. It has been implemented this way to ensure an easy comparison between two kind of waveforms. The three-phase waveform has appearance as in figure 56.

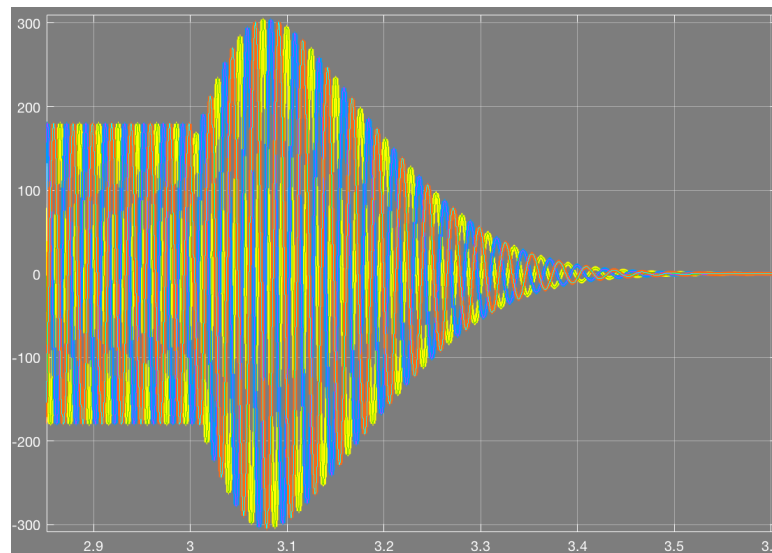

Figure 56: Transient three-phase voltage waveform

The first three simulations are very close to their real-world counterpart. The peak value of the transient voltage is very similar to the ones obtained in the tests. The shape of the simulation waveforms has a similar resemblance to ones of the oscilloscope. With exception of the second case, the time of transient waveform always falls short.

The second simulation has a greater peak value than the real-world testing. The transient waveform time is also longer in the simulation. However, the waveform looks very much like the waveform of the tests.

In the fourth simulation, there is no overvoltage whereas there is clearly an overvoltage in the laboratory tests. Even in the transient time there is a big difference of 200 ms. Even the form of the waveform is different. It is safe to say that the simulated waveform is mitigated in every aspect.

In the fifth case, during the test, the overvoltage seems to be the result of change in operational condition. Many factors contribute to the momentarily overvoltage. One of these factors is an abrupt interruption of the electricity in a critical moment. It is safe to say that this overvoltage was not produce by the capacitive compensation.

Even though, the second peak of transient waveform has approximately the same value as the one observed in tests. It is around 100 V. And the transient waveform time is also close to its real-world counterpart.

The current consumed in the simulation is always superior than its real-world counterpart. There is no pattern that could describe this augmentation in every current. In the case no. 34, the value of simulated current is exceptionally higher.

The current is also affected by the overvoltage. The magnitude of current is augmented in the same fashion as of voltage, resulting in an overcurrent. The waveform of this transient current is as same as the waveform of the transient voltage. The duration of the waveform is also the same as the voltage's duration.

For instance, in figure 56, it can be seen the three-phase transient waveform correspondent to test no. 7. The form of this transient waveform is same as the transient voltage waveform.

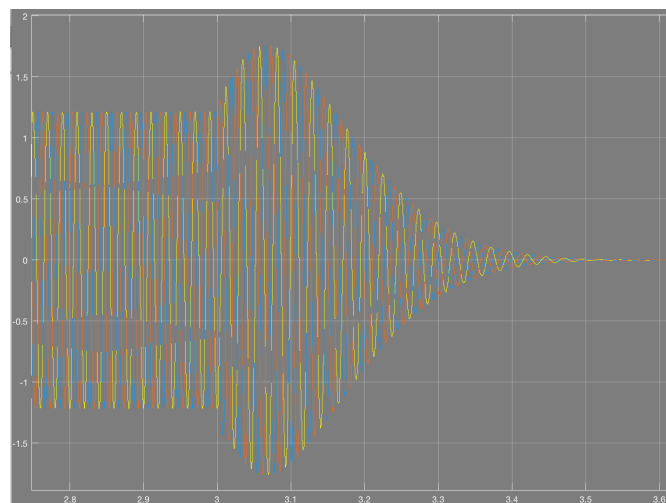

Figure 57: Transient waveform of the three-phase current

When someone talks about voltage of 220 V, he or she refers to the rated voltage which is the RMS value of voltage. In the figure 58, the RMS value of the transient voltage can be seen. Before turning the power off the RMS value of voltage was constant. After interrupting the power supply, the RMS value started to behave like a waveform. The reasons behind this pattern are probably the changes in the peak value and frequency.

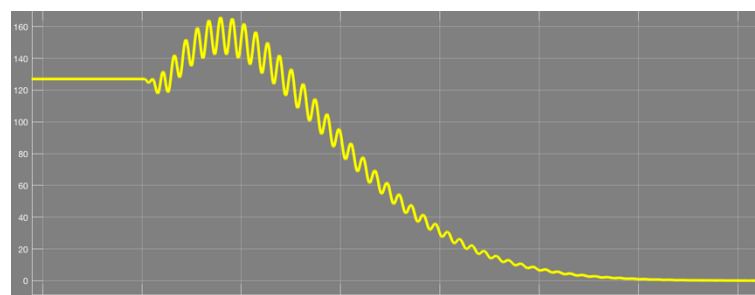

Figure 58: Transient waveform of the RMS

The intensification and mitigation of the waveforms in the simulation in respect to real-world testing can be a product of many unforeseen factors and reasons. The most important thing to emphasize here is the fact that even simulated circuits experience overvoltage and under the same condition as the real circuits.

Having said that, it can be confirmed that the measurements observed in the laboratory tests are valid.

6 Conclusion

After many hours of laboratory testing and simulation, it is clear that the capacitive compensation in the motors causes overvoltage under certain conditions. Without capacitive compensation there was no overvoltage produced in either motors.

Apart from the effect of load, the voltage received by the motor and the capacitor bank influenced greatly on the voltage production. The overvoltage manifested when the motor received voltage lower than the rated voltage and the capacitor bank received the voltage that is has been designed for.

The Matlab software has allowed the validation of the data collected in the laboratory. The simulation results were very similar to their real-world counterparts. Without this powerful tool it would have been very difficult to know if the lab results were actually true or just some coincidences.

The objectives outlined in the introduction have been met. The overvoltage produced by the motor was observed and how it can be affected by the load connected to the motor's shaft. It was also observed that how the voltage received by motor and capacitor banks can change the voltage production.

This dissertation has served the purpose of outlining a problem that exists in the ships and industrial installations. More work is needed in this field in order to collect more data. The next dissertation in this field should also experiment with more powerful induction motors. The collected data may help the companies to come up with a solution to counter attack this phenomenon.

7 Bibliography

1. Casals Torrens, Pau; Bosch Tous, Ricard. Máquinas eléctricas: Aplicaciones de ingeniería eléctrica a instalaciones navales y marinas. Prácticas. 1st ed. Barcelona: UPC, 2005. ISBN 84-8301-813-6
2. Fraile Mora, Jesús. Máquinas Eléctricas. 2nd ed. Barcelona: Servicio de publicaciones. Colegio de Ingenieros de Camino, Canales y Puertos, 1993. ISBN 84-7493-143-6
3. Carlson, A. Bruce. Circuitos. 1st ed. Australia: Thomson Learning, 2001. ISBN 970-686-033-9
4. Glendinning, Eric H. English in electrical Engineering and Electronics. 13th ed. Oxford: Oxford University Press, 1992. ISBN 0 19 437517 X
5. Hayt, William H.; Kemmerly, Jack E.; Durbin, Steven M. Engineering Circuit Analysis. 8th ed. New York: McGraw-Hill, 2012. ISBN 978-0-07-131706-1
6. Corrales Martín, Juan. Cálculo Industrial de Máquinas Eléctricas: Tomo I. Barcelona: U.P.B., 1976. ISBN 84-600-6752-1
7. Slemon, G.R.; Straughen, A. Electric Machines. 2nd ed. Reading- UK: Addison-Wesley Publishing Company, 1980. ISBN 0-201-07730-2