

MSc in Photonics

Universitat Politècnica de Catalunya (UPC)
Universitat Autònoma de Barcelona (UAB)
Universitat de Barcelona (UB)
Institut de Ciències Fotòniques (ICFO)



PHOTONICSBCN

<http://www.photonicsbcn.eu>

Master in Photonics**MASTER THESIS WORK****INVESTIGATION OF THE LIGHT
PROPAGATION IN THE HUMAN FOREARM****Irene Vázquez Martín**

Supervised by Oliver Fugger and Christian Zoller
(ILM)
and Crina Cojocaru
(UPC)

Presented on date 8th September 2017

Registered at

ETSETB Escola Tècnica Superior
d'Enginyeria de Telecomunicació de Barcelona

Investigation of the light propagation in the human forearm

Irene Vázquez Martín

Head Material and Tissue Optics group, Institut für Lasertechnologien in der Medizin und Meßtechnik (ILM), Helmholtzstraße 12, 89081 Ulm, Germany.

E-mail: irene.vazquezma@gmail.com

Abstract. In the present study it is investigated the applicability of spectrally resolved reflectance at a certain distance from the incident beam to determine the optical coefficients of multi-layered tissues. The main motivation of this investigation is to achieve the simplest multi-layered model as possible which describes, within a given tolerance range, the light propagation in human forearm and its optical properties. For getting to this end it is investigated which assumptions within the model are acceptable. We found out that the thickness of the first layer in a two-layered model is a parameter suitable to be fixed, as it does not have a large negative influence on the fitting-results, and that it is expected to obtain better results with an absolute fit than with a relative one. Furthermore, this investigation was complemented with experimental spectrally resolved reflectance measurements performed on tissue-simulating phantoms of known optical properties and on human forearms by using optical fibers at different distances to deliver and detect reflected light by means of a CCD camera.

Keywords: Tissue optics, reflectance, Refractive Transfer Equation, optical properties.

1. Introduction

Understanding light propagation in biological tissue (such as skin, fat or muscle) is essential for effective and safe medical applications [1][2][3][4], as diagnosis and therapies. Currently, great efforts are made for determining the optical properties of biological tissue. The aim of obtaining these properties is to set the ability to describe the propagation of light in a multi-layered tissue. The biological tissue is an optically turbid medium, which means that it can both absorb and scatter light. It can be described by the transport theory with four optical coefficients [5][6]: the scattering coefficient μ_s , the absorption coefficient μ_a , the asymmetry factor g which is applied to the Henyey-Greenstein scattering phase function [7] and the refractive index n .

The model to describe light propagation in human tissue most used in almost all applications assumes homogeneous tissue [5][8]. In the case of studying the human forearm it is suitable to assume a layered tissue structure, in which each layer can be described as a homogenous medium. The incident light may travel through different tissues (it is assumed skin, fat and muscle) before it is reflected and hence a multi-layered model adapts to the investigation of the spectrally resolved reflectance in this kind of biological tissue.

Using the radiative transport equation it is possible to find solutions for a semi-infinite and homogeneous turbid medium in both frequency and time domains. This equation can be used for determining the aforesaid optical coefficients. This can be done, for instance, in an iterative way by using the radiative transport model to fit the theory, with the optical properties as free parameters, to the measured data.

In the present study it is investigated the applicability of spectrally resolved reflectance at a certain distance from the incident beam to determine the optical coefficients of multi-layered tissues. For this aim, it can be extended the analytical solution of the aforesaid radiative transport equation to

a multi-layered tissue-model. A different option could be to extend the Monte Carlo simulations, which is a numerical solution of the transport theory for semi-infinite and homogeneous turbid medium, to a multi-layered tissue-model.

The principal aim of this investigation is to achieve the simplest multi-layered model as possible which describes, within a given tolerance range, the light propagation in human forearm and its optical properties. For getting to this end it is important to find which assumptions within the model are acceptable. This means, for instance, get to know which optical parameters have the most impact in the model and which ones can be assumed to be constant with a certain value without a great negative influence in the investigation. More specifically, during this project it has been studied aspects such as the influence of wrong assumed optical properties for determining the remaining ones or the influence of the initial values of the fitting routine on the fitting result.

As well experimental spectrally and spatially resolved, relative and absolute, reflectance measurements have been done on tissue-simulating phantoms of known optical properties and on human forearms by using optical fibers at different distances to deliver and detect reflected light by means of a CCD camera.

2. Theory

The propagation of light in biological tissue can be described by the transport theory. Depending on the propagation distances that we want to investigate it is suitable to use different approximations of the transport theory for photons. There are three different scales: the diffusion theory, the radiative transfer equation and the Maxwell equations. The Maxwell equations is the most exact approximation for describing the photons propagation and it is suitable for describing very short distances, as micro-scale. The radiative transfer equation works in a meso-scale and it is the suitable theory for our study, as we are working with a few millimetres distances. And the diffusion theory is the roughest approximation, it works in a macro-scale and it describes wrong the photons' propagation for short distances, up to a few millimetres.

In this section it is described the model of the transport theory that it is used to determine the absorption and scattering coefficients from the spectrally resolved measurements of diffuse reflectance.

The transport theory can be solved numerically by using the Monte Carlo simulations or analytically by the radiative transfer equation (RTE). Usually it is necessary to introduce approximations into the RTE for obtaining analytical solutions. These include, but are not limited to, the delta-Eddington approximation, the Fokker-Planck approximation, the Boltzmann-Fokker-Planck approximation, the generalized Fokker-Planck approximation, the Fokker-Planck-Eddington approximation and the generalized Fokker-Planck-Eddington approximation [9]. Recently, an analytical solution of the RTE was found by André Liemert [10] for the specific case of two dimensional layered medium to calculate the spatially resolved reflectance in the steady-state (CW) domain. This analytical solution is used in this project as a model to describe the light propagation in the human forearm and to perform related theoretical investigations. For determining the spectrally resolved reflectance of one specific distance with respect to the incident beam, the reflectance at the aforesaid distance must be calculated for a wavelength dependent set of optical properties ($\mu_a(\lambda)$, $\mu_s'(\lambda)$) in the wavelength range of interest. We are obtaining in this way the spectrally resolved reflectance.

3. Materials and Methods

3.1. Experimental set-up

The experimental set-up of the spatially and spectrally resolved reflectance measurements is shown in Fig. 1.

This measurement technique was already theoretically developed by Wilson, Farrell and Patterson [11]. The illumination in our set-up of the phantom or of the biological tissue and the collection of the reflected light is performed by a set of 14 optical fibers. All these fibers are joined by a measuring head and positioned at distances, with respect to the illumination fiber, of 1, 2, 3, 4, 6, 8, 10, 12, 14, 16, 19, 22 and 25 mm. The light from a halogen lamp is coupled into the illumination

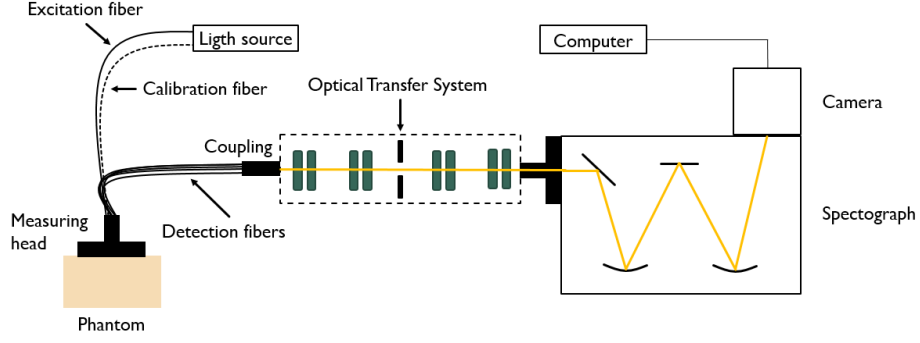

Figure 1. Experimental set-up for the measurement of spatially and spectrally resolved reflectance.

fiber of the measuring head. After detecting the reflected light by the detection fibers, the light is directed to an optical transfer system, in which several optical density fibers are located. This system prevents the CCD camera to get saturated and enlarges the dynamic range. Afterwards, the light is routed to the entrance slit position of an imaging spectrograph. The 150 lines/mm grating in the spectrograph allows to cover a wavelength range from 504.24 to 991.43 nm which can reach a spectral resolution of 1 nm, minimum resolution needed during this project. Finally the light collected by the detection fibers arrives to a CCD camera and appears as an image at the computer, which can be analysed by a specific program. The system measures all the desired wavelengths and all the distances at a time. The aforesaid program allows to get the mean intensity of a desired number of measurements as a function of the distance (spatially resolved reflectance) and as a function of the wavelength (spectrally resolved reflectance).

3.2. Fitting Routine

The data processing and analysis of the data files are performed using Matlab software. The absorption and scattering coefficients can be determined by fitting the solution of the radiative transfer equation [12] for the reflectance to the measurements, as shown in Fig. 2. The absorption and scattering coefficients can be described as in (1) and (2).

$$\mu_a = c_{fat} \cdot \mu_{fat} + c_{water} \cdot \mu_{water} + c_{oxyh.} \cdot \mu_{oxyh.} + c_{deoxyh.} \cdot \mu_{deoxyh.} + c_{mel.} \cdot \mu_{mel.} \quad (1)$$

$$\mu'_s = a \cdot \left(\frac{\lambda (nm)}{633} \right)^b \quad (2)$$

The absorption coefficient of each layer can be described as the linear combination of the absorption spectrum of each main absorber, which exists in the medium, multiplied by its concentration at the corresponding layer. And the scattering coefficient of each layer can be described with the power law, in which a and b are the scattering parameters of the corresponding layer.

In the fitting routine a trust-region-reflective algorithm is used. By varying the concentration of the main absorbers and the parameters a and b of (2), forward calculations with different sets of μ_a and μ'_s are compared with the measurements. By calculating the least square error the optical properties or the concentrations of the main absorbers can be determined.

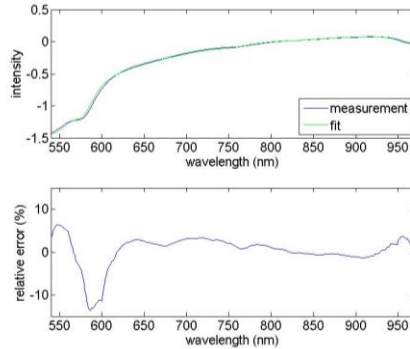

Figure 2. Spectrally resolved reflectance calculated by an analytical solution of the RTE for a two-layered system and relative fitted to an in-vivo human forearm measurement. The relative error represents the relative difference between the forward calculation and the measurement. The analyzed distance is 4 mm.

It was necessary as well to introduce another fitting parameter, which we called “factor”. This factor is related to the existence of certain constant discrepancies between the theoretical calculations and experimental measurements. This “factor” is necessary for fitting experimental measurements. We will refer as relative fits to the ones in which this factor is a free parameter and absolute fits to the ones in which it is constant.

Hence, the fitting routine software is able to determine the absorption and scattering coefficients of each layer by determining first the concentrations of the absorbers and the scattering parameters of the corresponding layer. The information that has to be necessarily provided to the software is: the mean cosine value g , the refractive index n , the Gaussian beam radius of the incident beam r_w , the evaluated detecting distance d , the wavelength region and step size, the thickness of the different layers (L for the first layer when considering a two-layered system) and, finally, which parameters are going to be fixed (and their value) and which ones are going to be fitted during the routine.

Unless stated otherwise we will consider $g = 0.85$, $n = 1.4$ and $L = 1 \text{ mm}$.

4. Results

4.1. Theoretical considerations

In this section we first present some theoretical results evaluating the influence of applying *wrong pre-knowledge* of the scenario, i.e. assuming wrong values for the fixed parameters on the fitting routine results. Being able to assume the value of a specific parameter with a certain error without introducing a large negative influence into our fitting-results, would simplify importantly our multi-layered model representing the measuring scenario.

This is followed by a second theoretical study in which the *influence of the initial values* given to the fitting routine software is evaluated.

After these studies efforts will be made to apply the acquired knowledge to different *in vivo* measurements on human forearm or on different skin-imitating phantoms. All the theoretical investigations have been done for a distance of 4 mm with respect to the source and the wavelength region [500, 1000] nm.

Wrongly fixed parameters investigation in semi-infinite system

Fig. 3 shows the results obtained in a slab system when the scattering parameters a and b are assumed with a 10 % of error. The results are compared with the known absorber’s concentrations of the forward theoretical calculation that is being used as a measurement to be fitted with our model. The concentrations of the main absorbers should represent for our knowledge normal concentrations in humans.

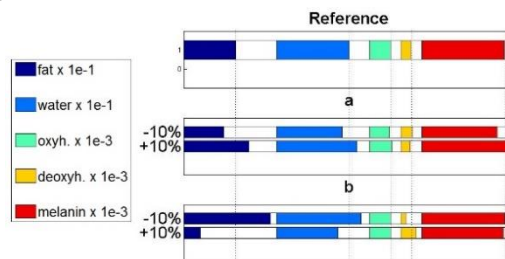

Figure 3. Reference absorbers’ concentrations at the upper subplot (fat concentration 0.5, water concentration 0.7, oxyhaemoglobin concentration 0.002, deoxyhaemoglobin concentration 0.001 and melanin concentration 0.008) and, at the two lower ones, the concentrations obtained by relative fitting a beforehand known forward calculation which represents the spectrally resolved reflectance of a semi-infinite biological tissue. The scattering parameters are constants during the fit and they are fixed with a +10 % or -10 % of error with respect to their real values. The evaluated distance is 4 mm and the thickness of the first layer is 1 mm.

The main conclusion that can be extracted from this graph is that fat concentration is very difficult to fit when introducing an error in any of both scattering parameters. In a general overview, the remaining parameters are not that highly influenced. Comparing the positive and negative errors it is important to conclude that it does not matter if we over or underestimate the parameter values, as the achieved error is approximately the same.

Wrongly fixed parameters investigation in two-layered system

The same procedure is followed now for a two-layered system and the results are shown in Fig. 4. In this case is studied the influence of a wrongly assumed first layer's thickness on the resulting concentrations and the influence of the scattering parameters of both layers on the concentrations of the absorbers of the second layer. The influence on the first layer can be obtained from the slab investigation.

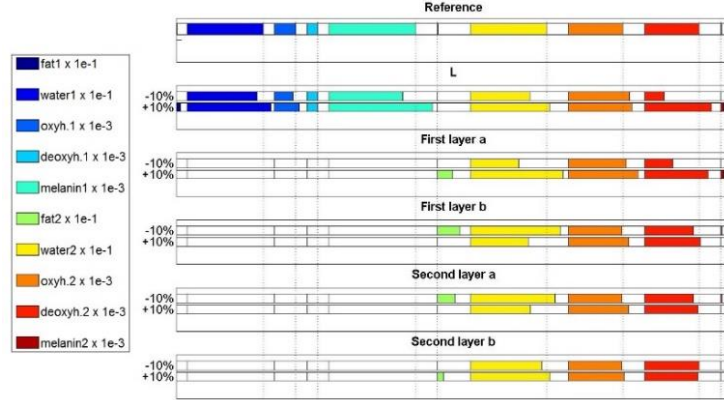

Figure 4. Absorbers' concentrations obtained in the same conditions as in the Fig. 3 but considering in this case a two-layered system and with different reference values (First layer: fat concentration 0, water concentration 0.7, oxyhaemoglobin concentration 0.002, deoxyhaemoglobin concentration 0.001 and melanin concentration 0.008; Second layer: fat concentration 0, water concentration 0.7, oxyhaemoglobin concentration 0.005, deoxyhaemoglobin concentration 0.005 and melanin concentration 0). It is evaluated as well the influence of the first layer's thickness when it is wrongly fixed.

We can conclude from this investigation that the wrong assumption of the first layer's thickness introduces an error not bigger than 15 % if it is overestimated. The results are more negatively influenced by the scattering parameters of the first layer. Then, it is more suitable to wrongly fix the scattering parameters of the second layer than of the first one. In general it is better to overestimate the value of a and underestimate b (less negative).

Initial parameters relative investigation in semi-infinite and two-layered systems

To investigate the influence of the initial parameters of the fitting routine on the final results we introduce a certain percentage of error on the initial values with respect to the known real values of the forward calculation. This is introduced parameter by parameter while the remaining ones are set with the right value. All the parameters are relative fitted during the routine.

The results for a relative fit of a slab and two-layered systems are shown in Fig. 5.

From the investigation of the slab system it can be conclude that both scattering parameters and the melanin concentration affect importantly the fit. The error of a and of the melanin concentration goes up to 50 % and the one of b up to 25 %. The blood concentrations affect more negatively to the fit as the corresponding initial values get further from the real values; but if the initial assumption is not too far from the real value, the fit is nearly not affected by these variables. And the "factor" and the water and fat concentrations nearly do not affect negatively the fit. During this investigation we could realize that the first scattering parameter or the melanin concentration or the "factor" approximately changes in the same way the fit; this pose a difficulty for the fitting routine software for determining which solution is the correct one. So probably, an absolute fit will fix to a certain extent this problem.

From the two-layered system investigation it can be extracted that all the parameters are similarly affected as in the slab system. The only big and important difference is that, when the error is introduced into the initial values of the second layer, just the parameters of the second layer are affected; the fitting error of the first layer's parameters is not bigger than 20 % for a few cases but in general not bigger than 10 %. Probably, fixing some well-known absorbers' concentrations, as the fat concentration is known to be zero in skin and muscle layers or the melanin concentration that it is known to be zero in fat and muscle layers, will improve the fitting results.

In general it seems to be better to overestimate the scattering parameters and underestimate the melanin concentration.

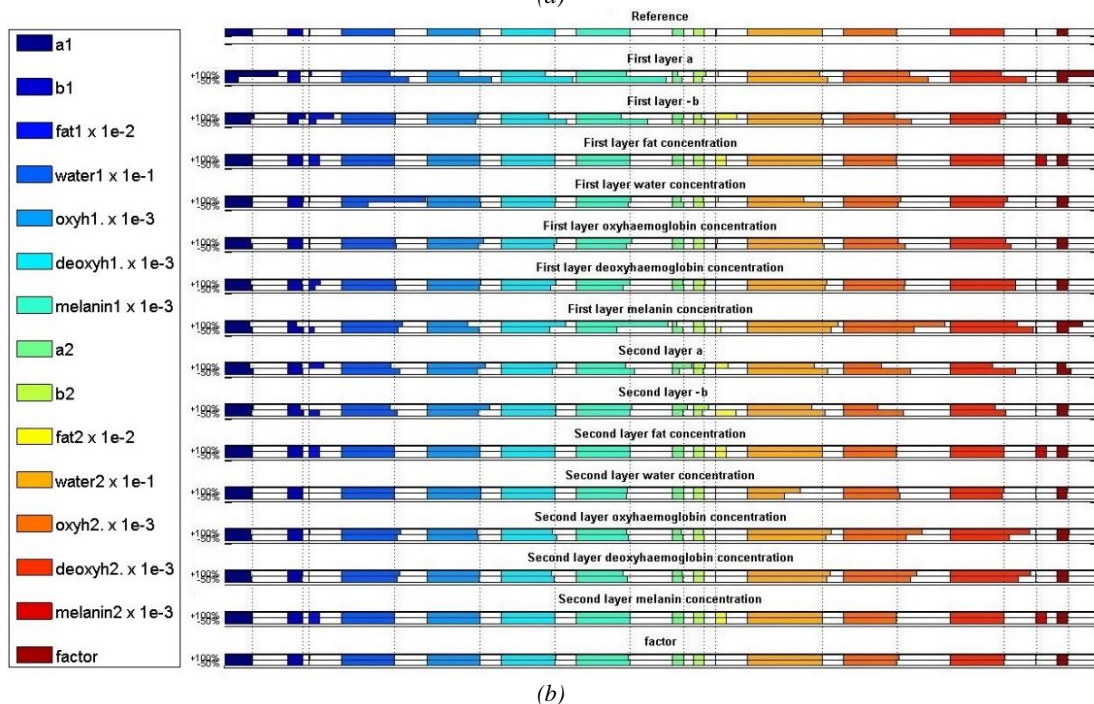
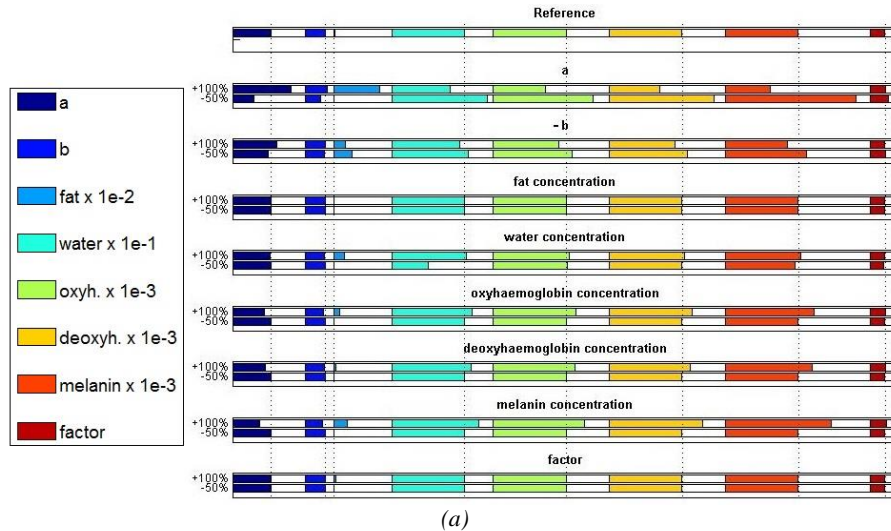

Figure 5. Optical properties obtained by relative fitting a beforehand known forward calculation which represents the spectrally resolved reflectance of a (a) semi-infinite or (b) two-layered biological tissue. The first layer's thickness is a constant at the two-layered system and it is set to 1 mm. All the optical parameters are fitting variables. It is evaluated how it influences the results to apply a -50 % or +100 % of error at all the initial values, one by one, with respect to their real values. The reference values are shown in the upper subplot of both plots (First subplot: a 2.68, b 1.39, fat concentration 0, water concentration 0.5, oxyhaemoglobin concentration 0.005, deoxyhaemoglobin concentration 0.005, melanin concentration 0.005 and factor 1. Second subplot, first layer: a 2.68, b 1.39, fat concentration 0, water concentration 0.5, oxyhaemoglobin concentration 0.005, deoxyhaemoglobin concentration 0.005 and melanin concentration 0.005; second layer: a 1.045, b 0.926, fat concentration 0, water concentration 0.7, oxyhaemoglobin concentration 0.005, deoxyhaemoglobin concentration 0.005 and melanin concentration 0; factor 1).

Initial parameters absolute investigation in semi-infinite and two-layered systems

The same procedure but for an absolute fit of slab and two-layered systems are shown in Fig. 6. During this investigation, except the initial values of a which introduce errors that nearly reach a 40 %, the remaining parameters do not even go so far to introduce errors of 10 %. Focusing now in the scattering parameter a , it can be conclude that the introduced errors are lower than the ones of the relative fit; not reaching a 10 % of error when this scattering parameter is not assumed too wrong. As expected, removing the "factor", the a parameter and the melanin concentration are better fitted. In a general overview, the improvement with the absolute fit with respect to the relative fit is significant.

For the case of a two-layered system, the most remarkable change is obtained at the scattering parameter a and at the melanin concentration, as it was expected. However, this improvement is not as big as the one obtained at the slab system. As said before, this improvement may increase by fixing some certain concentrations which are known beforehand.

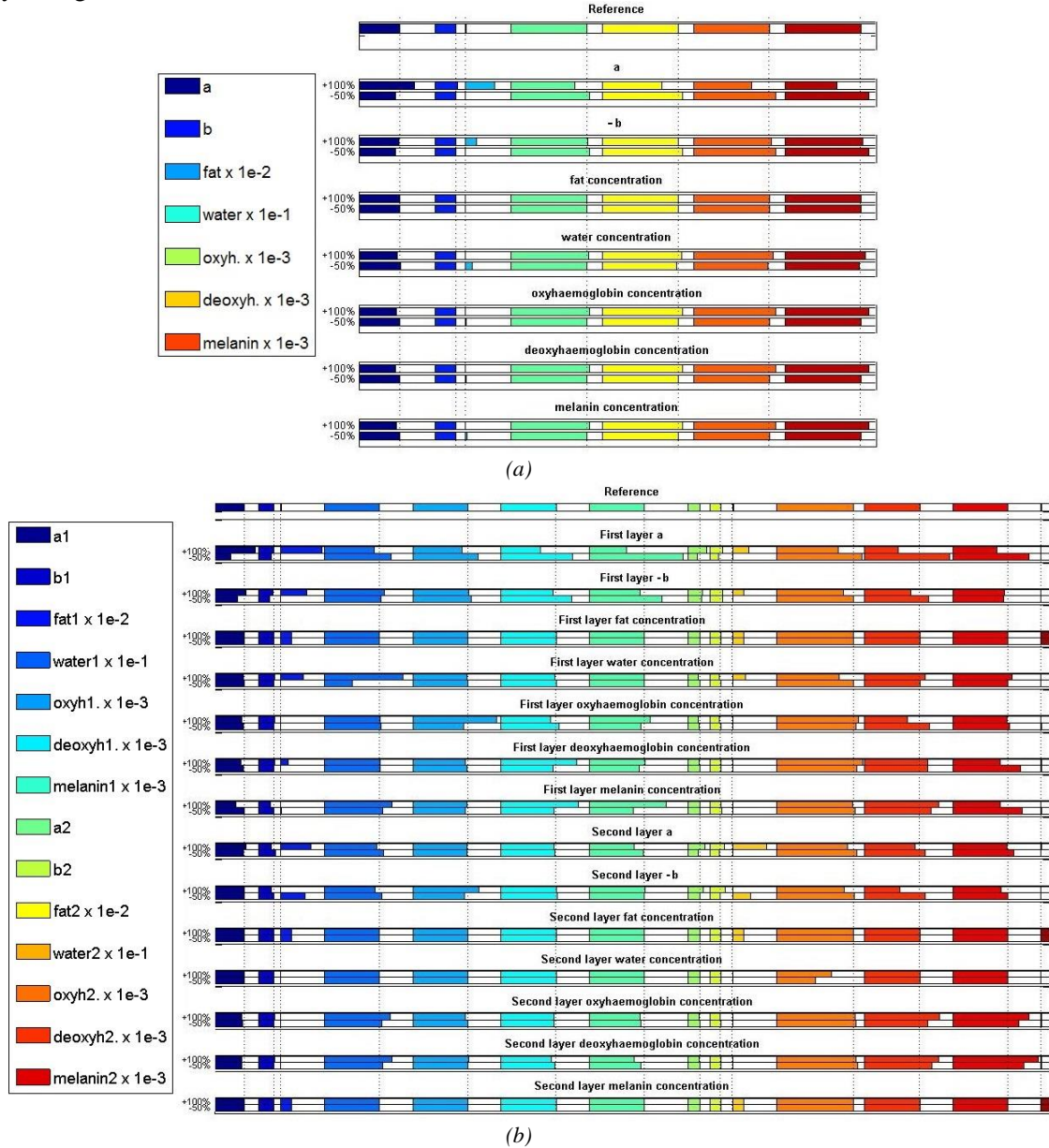

Figure 6. Optical properties obtained by absolute fitting a forward calculation which represents the spectrally resolved reflectance of a (a) semi-infinite or (b) two-layered biological tissue, in the same conditions as in the Fig. 5.

Initial parameters absolute investigation in two-layered system with fixed concentrations

The results of the absolute fit of a two-layered system when some certain concentrations are fixed to a previously known value are shown in Fig. 7.

At this investigation it was fixed the concentration of fat to zero at both layers and the melanin concentration to zero at the second layer. The most remarkable improvement achieved is at the water, oxygenated blood and deoxygenated blood concentrations fit.

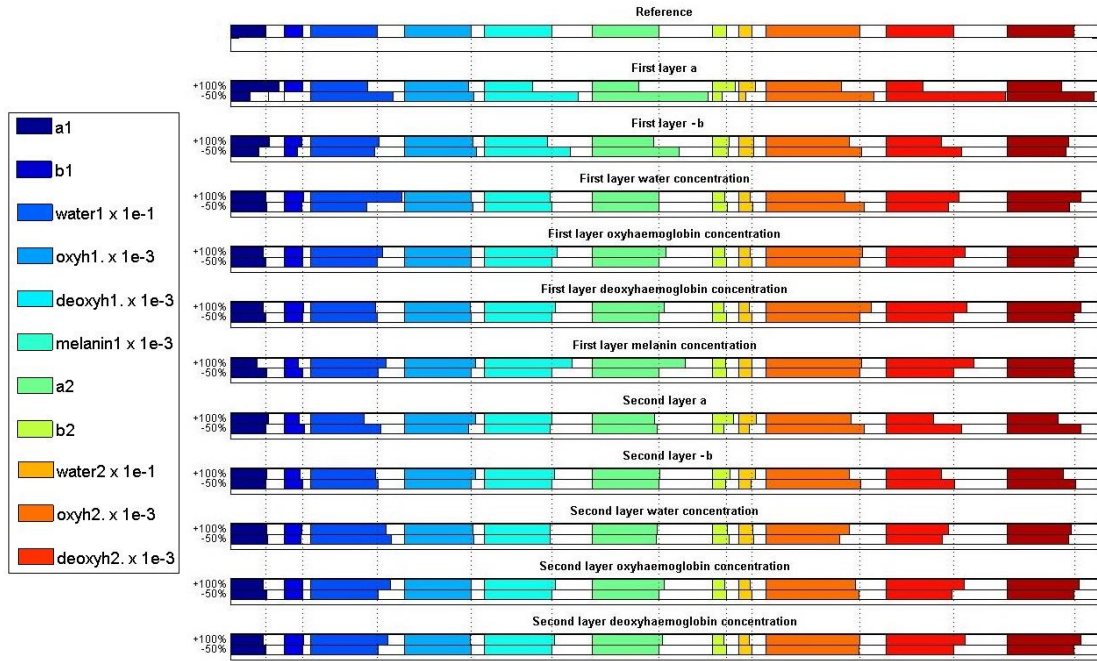

Figure 7. Optical properties obtained by absolute fitting a forward calculation which represents the spectrally resolved reflectance of a two-layered biological tissue, in the same conditions as in the Fig. 5 but fixing the fat concentration of both layers and the melanin concentration of the second layer to zero.

The outcome of this theoretical investigation then is that first layer's thickness can be fixed without influencing the investigation too negatively, if it is overestimated, and that, if it is necessary to fix the scattering parameters, it is more suitable to overestimate a and underestimate b . Furthermore, from the initial values investigation we can expect to obtain better results by doing an absolute than a relative fit, for both slab and two-layered systems.

4.2. *In vivo* measurements

Experimental investigations can be done at this point by applying the outcome of the theoretical investigations as preliminary knowledge for fitting *in vivo* measurements. The following investigation shows how fixing with wrong values the scattering parameters of both layers on a two-layered system and how different initial values affect the final result of the fitting routine as well in experimental investigations.

For this investigation, the tested subject was chosen by searching a spectrum in which the characteristic fat peak is invaluable. In this way we can negligible the fat concentration in any layer and assume to be studying a two-layered real system, being then the layered-system compound by skin and muscle. The evaluated distance is 4 mm. The results of this investigation are shown in Fig. 8 and Table 1.

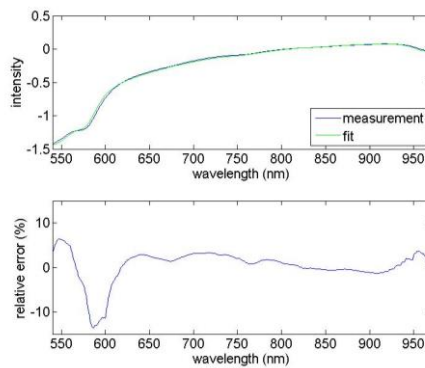

Figure 8. Spectrally resolved reflectance calculated by an analytical solution of the RTE for a two-layered system and relative fitted to an *in-vivo* human forearm measurement. The relative error represents the relative difference between the forward calculation and the measurement. The analyzed distance is 4 mm. The scattering parameters are fixed with values obtained from the literature [3] for skin and muscle. The fat concentration of both layers and the melanin concentration of the second layer are fixed to zero, as this is known to be fulfilled for skin and muscle.

Table 1. Optical properties obtained at the conditions commented at Fig. 8.

a	b	fat	water	oxyh.	deoxyh.	melanin	factor
First layer							889
4.0 (fixed)	-1.722 (fixed)	0 (fixed)	0.333	$4.8 \cdot 10^{-4}$	$3.6 \cdot 10^{-6}$	0.003	
Second layer							
1.045 (fixed)	-0.926 (fixed)	0 (fixed)	0.452	0.001	0.003	0 (fixed)	

The wavelength region that was chosen for the fit is from 540 to 970 nm. The scattering parameters were chosen from the literature [3], specifically for skin and muscle. The high absorption of blood and melanin in the blue region combined with the lower efficiency of the CCD camera at the ends of the considered spectrum (from 500 to 1000 nm) made us take the decision of removing this two regions from the fit. When testing a fit in the whole wavelength region between 500 and 1000 nm the highest relative error was found approximately between 500 and 540 nm and in the NIR from 950 to 1000 nm.

In a general overview, after searching at literature, it is expected to obtain bigger concentrations of the absorbers. However, all the concentrations have the expected order of magnitude, except the blood concentrations of the first layer, which are expected to be higher, and the rate between the oxygenated and deoxygenated blood of the second layer, as the concentration of oxygenated blood is expected to be the highest. Maybe this needed rise could be reached by changing to an absolute fit. Furthermore, the fixed scattering parameters could not be the right ones and we have already seen that the results are highly influenced by the scattering parameters of the first layer when are wrongly assumed.

The results of fitting the same measurement in the same conditions, but just changing the initial values, the results shown in Tables 2 and 3.

Table 2. Optical properties obtained from a spectrally resolved reflectance calculated by an analytical solution of the RTE for a two-layered system and relative fitted to an in-vivo human forearm measurement and the respective fitting relative error plot. The fat concentration of both layers and the melanin concentration of the second layer are fixed to zero, as this is known to be fulfilled for skin and muscle.

a	b	fat	water	oxyh.	deoxyh.	melanin	factor
First layer							998
2.360	-0.160	0 (fixed)	0.046	$5.3 \cdot 10^{-12}$	$1.1 \cdot 10^{-6}$	0.005	
Second layer							
1.408	-0.873	0 (fixed)	0.425	0.006	0.003	0 (fixed)	

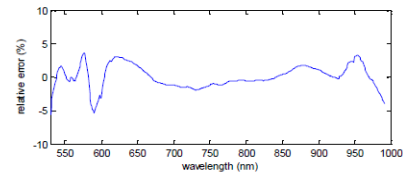
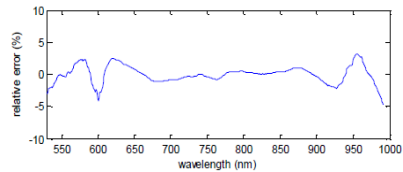

Table 3. Optical properties obtained at the same conditions as in the case showed in Table 2 but starting the fitting routine with different initial values and the respective fitting relative error plot.

a	b	fat	water	oxyh.	deoxyh.	melanin	factor
First layer							907
2.911	-0.329	0 (fixed)	0.094	$7.9 \cdot 10^{-10}$	$6.2 \cdot 10^{-4}$	0.003	
Second layer							
5.615	-1.166	0 (fixed)	0.331	0.006	$2.5 \cdot 10^{-7}$	0 (fixed)	



As expected, the initial values influence the results of the fitting routine. The biggest change is found in the scattering parameters. This goes along with the conclusions obtained from the theoretical investigation, where the scattering parameters were importantly influenced by the initial values of any parameter.

A possible way of improving the fitting results could be to separate the routine into two steps: fit the first part of the spectrum, up to 700 nm, evaluating a shorter distance and fit the second part of the spectrum, from 700 nm, evaluating a longer distance. It is known that we can obtain more information about blood and melanin at shorter distances, where the light has travelled a short path and just the high absorption of these two tissue components is influencing the final result of the reflectance. Furthermore, for longer distances we will obtain a higher amount of information

about fat and water concentrations because their weak absorption needs longer distances to make any change in the final reflectance.

Following the aforesaid procedure the results shown in Fig. 9 and in Table 4 are obtained.

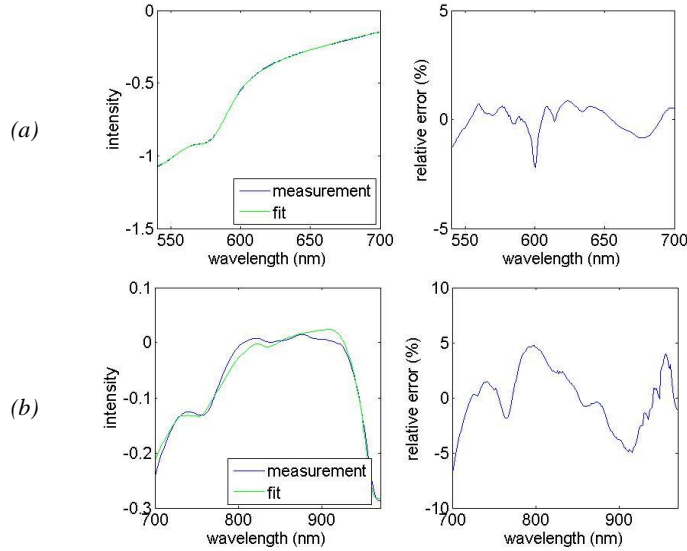

Figure 9. Spectrally resolved reflectance calculated at the same conditions as in Fig. 8 but dividing the fitting routine into two steps: (a) fit the first part of the spectrum, up to 700 nm, evaluating a shorter distance (3 mm) and (b) fit the second part of the spectrum, from 700 nm, evaluating a longer distance (10 mm).

Table 4. Optical properties obtained at the conditions commented at Fig. 9.

$\lambda = [540, 700] \text{ nm}$							
a	b	fat	water	oxyh.	deoxyh.	melanin	factor
First layer							
4.0 (fixed)	-1.722 (fixed)	0 (fixed)	0.500	$1.3 \cdot 10^{-4}$	$1.8 \cdot 10^{-5}$	0.002	429
Second layer							
1.045 (fixed)	-0.926 (fixed)	0 (fixed)	0.700	0.004	0.004	0 (fixed)	
$\lambda = [700, 970] \text{ nm}$							
a	b	fat	water	oxyh.	deoxyh.	melanin	factor
First layer							
4.0 (fixed)	-1.722 (fixed)	0 (fixed)	0.284	0.004	$5.5 \cdot 10^{-5}$	0.003	777
Second layer							
1.045 (fixed)	-0.926 (fixed)	0 (fixed)	0.442	0.001	0.001	0 (fixed)	

The results have not notably changed with respect to the fit shown in Table 1. But if we calculate the percentage of oxygenation of blood in the different layers the values are more plausible. Anyway, this should be investigated more in detail as it provides promising fitting results and since in this way the different characteristic peaks of the absorbers are highlighted, what should help the fitting routine to obtain their concentrations.

It is expected, taking as a reference the theoretical investigation's results, that absolute fits will give better results than the relative ones. We have supposed so far that the "factor" has no wavelength dependence, which can be a wrong assumption. For investigating this issue some phantom measurements have been done. Fitting these measurements, which optical properties are well known, it is possible to obtain the real "factor" of our experimental set-up as a function of the wavelength. In this way we are able to use this "factor" to do absolute fits instead of relative fits.

The results shown in the Fig. 10 represent the "factor" obtained with the phantom HP3 at distance 4 mm.

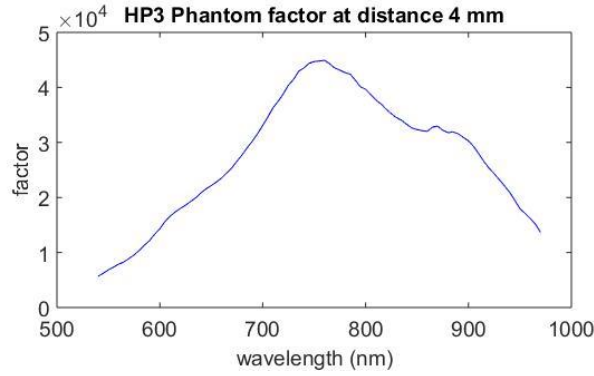

Figure 10. "Factor" between a relative and an absolute fit obtained from a tissue-type phantom at distance 4 mm.

One way to check if this “factor” works right when using it in an absolute fit could be to use it for fitting the remaining tissue-type phantoms, HP1, HP2 and HP4. These phantoms have the same absorption spectrum but a progressive increase of the scattering coefficient, being the HP1 the one with lower scattering values and HP4 the one with higher. The “factor”, and the fitting routine, would be working properly if the resulting optical parameters of the fits are similar to the real ones of the corresponding phantom. This investigation is shown in Table 5 and Fig. 11. They show the expected values and the obtained results from the absolute fit of HP1, HP2 and HP4 measurements using the “factor” obtained with HP3.

Table 5. Absolute fit the HP phantoms by using the "factor" obtained from the phantom HP3.

HP1				HP2				HP4			
a	b	concent.	factor	a	b	concent.	factor	a	b	concent.	factor
<i>Real values</i>				<i>Real values</i>				<i>Real values</i>			
0.461	-1.131	1	1	0.773	-1.083	1	1	1.452	-1.183	1	1
<i>Fitting results</i>				<i>Fitting results</i>				<i>Fitting results</i>			
0.682	-1.846	1.000	1.075	0.900	-1.676	0.962	1.018	1.496	-1.331	0.995	0.896
<i>Relative error (%)</i>				<i>Relative error (%)</i>				<i>Relative error (%)</i>			
48	39	0	7.5	16	55	3.8	1.8	3	13	0.5	10

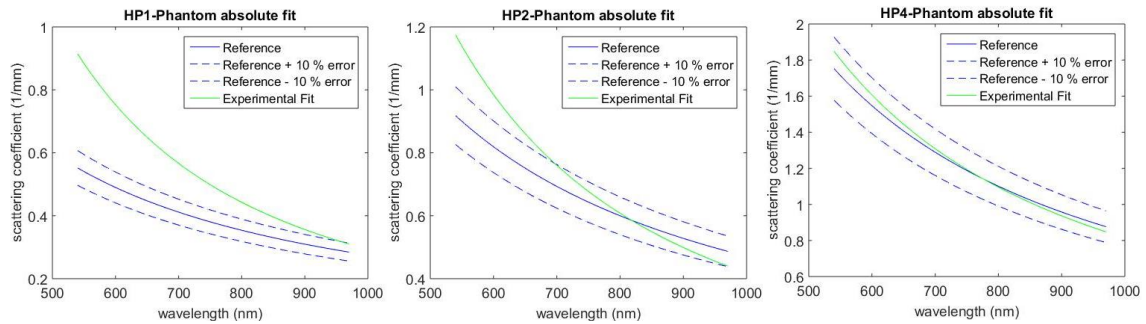

Figure 11. Scattering coefficient obtained by an absolute fit of the Phantoms HP1, HP2 and HP4 by using the "factor" obtained from the phantoms HP3 and the corresponding comparison with their real values and a 10 % of error of these real values.

Comparing these fitting results with the real values it can be seen that, as the scattering coefficient is more different to the one of the phantom which was used for obtaining the absolute “factor”, the worst fitting-results are obtained. The concentration of the absorber in the phantom must be 1 and the “factor”, as this is an absolute fit, must be 1 as well. This is fulfilled in all cases with a very low relative error.

In principle, as there are no fixed parameters and the used initial values are the real values, it was expected to obtain a perfect fit of the phantoms. One possible reason for these errors could be that there are more than one possible solutions for the same spectrum. Another possibility could be the existence of a systematic error in the set-up. In case this would be the reason, before continuing with *in-vivo* measurements’ fits this systematic error has to be fixed; but this is a promising way of obtaining better results. And a third option could be that the distance is not long enough for separating the information obtained from μ_a and from μ_s' , if μ_s' is low.

5. Conclusions

We tried to find which assumptions can be made in a multi-layered model to describe, within a given tolerance, the light propagation in human forearm and its optical properties, in order to achieve the simplest multi-layered model.

After investigating the influence of wrong assumed optical properties for determining the remaining ones or the influence of the initial values of the fitting routine on the result we can get some important conclusions out of these investigations. We can conclude from the first investigation that the thickness of the first layer can be fixed, being more suitable to overestimate it; and that it is more convenient to fix the scattering parameters of the second layer than the ones of the first one if necessary, being more suitable to overestimate a and underestimate b . And from the second investigation we can establish that it is expected to obtain in general better results by doing an absolute than a relative fit, for both slab and two-layered systems.

As well experimental spectrally and spatially resolved, relative and absolute, reflectance measurements have been performed. The results were not as expected after consulting some literature. Probably blood's concentration needs shorter wavelengths to be evaluated, as their characteristic peaks appear between 500 and 600 nm. As this is a conflicting wavelength region, it is needed to find a compromise. Furthermore, water's concentration may need longer wavelengths to be better fitted, as its characteristic peak appears between 900 and 1000 nm approximately. As a conclusion then, changing the considered wavelength region to [530, 1000] nm, for instance, may help the fitting routine to obtain better results. As well, better fitting results and more plausible values can be reached if the fitting routine is divided into 2 steps: fitting first the blood and melanin concentrations using a wavelength range from 500 to 700 nm and secondly the fat and water concentrations using a wavelength range from 700 to 1000 nm. Another important conclusion is that, if the scattering parameters are fixed, it is important to be well-known, as they can importantly influence the fit. And finally, a promising further investigation is to absolute fit real measurements using the HP phantoms' factor, since theoretically is expected to improve significantly the results.

6. Acknowledgements

I am indebted to my advisors, Oliver Fugger and Christian Zoller, for their help and encouragement throughout the learning process of this master thesis. Furthermore I would like to thank Prof. Dr. Kienle for introducing me to the topic as well for the support on the way. Also, I like to thank all the group members who have supported me throughout the entire process and helped me at any time I needed them.

7. References

- [1] Kienle A., Lilge L., Patterson M.S., Hibst R., Steiner R. and Wilson B.C. 1996 Spatially resolved absolute diffuse reflectance measurements for noninvasive determination of the optical scattering and absorption coefficients of biological tissue *Applied Optics* **35** (13) 2304-2314
- [2] Farrell T.J., Patterson M.S. and Wilson B. 1992 A diffusion theory model of spatially resolved, steady-state diffuse reflectance for the noninvasive determination of tissue optical properties in vivo *Med. Phys.* **19**(4) 879-888
- [3] Jacques S.L. 2013 Optical properties of biological tissues: a review *Phys. Med. Bio.* **58** R37-R61
- [4] van Veen R.L.P., Sterenborg H.J.C.M., Pifferi A., Torricelli A., Chiloidze E. and Cubeddu R. 2005 Determination of visible near-IR absorption coefficients of mammalian fat using time- and spatially resolved diffuse reflectance and transmission spectroscopy *Journal of Biomedical Optics* **10**(5)
- [5] Kienle A., Lilge L., Patterson M.S., Wilson B.C., Hibst R. and Steiner R. 1995 Investigation of multi-layered tissue with in-vivo reflectance measurements *SPIE* **2326** 212-221
- [6] Cuccia D.J., Bevilacqua F., Durkin A.J., Ayers F.R. and Tromberg B.J. 2009 Quantitation and mapping of tissue optical properties using modulated imaging *Journal of Biomedical Optics* **14**(2)
- [7] Toublanc D. 1996 Heny-Greenstein and Mie phase functions in Monte Carlo radiative transfer computations *Applied Optics* **35** 3270-3274
- [8] Kienle A., Patterson M.S., Dögnitz N., Bays R., Wagnières G. and van der Berg H. 1998 Noninvasive determination of the optical properties of two-layered turbid media *Applied Optics* **37**(4) 779-789
- [9] Sheng Q. 2013 Some approximations to the Radiative Transfer Equation and their applications *Theses and Dissertations University of Iowa*

- [10] Liemert A. and Kienle A. 2012 Analytical approach for solving the radiative transfer equation in two-dimensional layered media *Preprint submitted to Journal of Quantitative Spectroscopy*
- [11] Wilson B.C., Farrell T.J. and Patterson M.S. 1990 An optical fiber-based diffuse reflectance spectrometer for non-invasive investigation of photodynamic sensitizers in vivo *SPIE* **10306** 219-232
- [12] Krauter P., Reitzle K., Geiger S. and Kienle A. 2017 Determination of three optical properties from subdiffusive spatially resolved reflectance calculations *Journal of Biomedical Optics* **22(7)**