

<https://helda.helsinki.fi>

Use of VEGF-D gene to prevent restenosis

Alitalo, Kari Kustaa

US Patent and Trademark Office
2013-06-04

Alitalo , K K , Ylä-Herttua , S , Hiltunen , M , Jeltsch , M M & Achen , M G Jun. 04 2013 ,
Use of VEGF-D gene to prevent restenosis , Patent No. US 8,455,453 B2 . <
<http://patft1.uspto.gov/netacgi/nph-Parser?patentnumber=8455453> >

<http://hdl.handle.net/10138/224719>

unspecified

Downloaded from Helda, University of Helsinki institutional repository.

This is an electronic reprint of the original article.

This reprint may differ from the original in pagination and typographic detail.

Please cite the original version.



(12) **United States Patent**
Alitalo et al.

(10) **Patent No.:** **US 8,455,453 B2**
(45) **Date of Patent:** **Jun. 4, 2013**

(54) **USE OF VEGF-D GENE TO PREVENT RESTENOSIS**

(75) Inventors: **Kari Alitalo**, Espoo (FI); **Seppo Ylä-Herttua**, Kuopio (FI); **Mikko O. Hiltunen**, Kuopio (FI); **Markku M. Jeltsch**, Helsinki (FI); **Marc G. Achen**, North Melbourne (AU)

(73) Assignee: **Vegenics Pty Ltd**, Toorak, Victoria (AU)

(*) Notice: Subject to any disclaimer, the term of this patent is extended or adjusted under 35 U.S.C. 154(b) by 1738 days.

(21) Appl. No.: **11/064,769**

(22) Filed: **Feb. 24, 2005**

(65) **Prior Publication Data**

US 2005/0256075 A1 Nov. 17, 2005

Related U.S. Application Data

(63) Continuation of application No. 09/427,657, filed on Oct. 26, 1999, now Pat. No. 6,958,147.

(60) Provisional application No. 60/105,587, filed on Oct. 26, 1998.

(51) **Int. Cl.**

A61K 48/00 (2006.01)
C12N 15/00 (2006.01)
C12N 15/09 (2006.01)
C12N 15/11 (2006.01)

(52) **U.S. Cl.**

USPC **514/44**; 435/455; 435/69.1; 536/23.1; 536/23.2

(58) **Field of Classification Search**

None
See application file for complete search history.

(56) **References Cited**

U.S. PATENT DOCUMENTS

5,087,244 A 2/1992 Wolinsky et al.
5,631,237 A 5/1997 Dzau et al.
5,652,225 A 7/1997 Isner
5,653,689 A 8/1997 Buelna et al.
5,674,192 A 10/1997 Sahatjian et al.
5,679,400 A 10/1997 Tuch
5,697,967 A 12/1997 Dinh et al.
5,700,286 A 12/1997 Tartaglia et al.
5,707,385 A 1/1998 Williams
5,713,860 A 2/1998 Kaplan et al.
5,749,848 A 5/1998 Jang et al.
5,776,184 A 7/1998 Tuch
5,776,755 A 7/1998 Alitalo et al.
5,779,729 A 7/1998 Severini et al.
5,785,965 A 7/1998 Pratt et al.
5,792,453 A 8/1998 Hammond et al.
5,795,898 A 8/1998 Brown et al.
5,799,384 A 9/1998 Schwartz et al.
5,800,507 A 9/1998 Schwartz
5,824,048 A 10/1998 Tuch
5,830,879 A 11/1998 Isner
5,924,048 A 7/1999 McCormack et al.
5,932,540 A 8/1999 Hu et al.

5,935,820 A 8/1999 Hu et al.
5,994,300 A 11/1999 Bayne et al.
6,040,157 A 3/2000 Hu et al.
6,121,246 A 9/2000 Isner
6,235,713 B1 * 5/2001 Achen et al. 514/12
6,338,709 B1 * 1/2002 Geoffrion et al. 600/3
6,583,276 B1 * 6/2003 Neufeld et al. 536/23.5
6,828,426 B1 * 12/2004 Hirata et al. 530/399

FOREIGN PATENT DOCUMENTS

WO WO-9524473 9/1995
WO WO-9624473 8/1996
WO WO-9639515 12/1996
WO WO-9705250 2/1997
WO WO-9709427 3/1997
WO WO-9717359 5/1997
WO WO-9717442 5/1997
WO WO-9807832 2/1998
WO WO-9819712 5/1998
WO WO-9820027 5/1998
WO WO-9824811 6/1998
WO WO-9833917 8/1998
WO WO-9849300 11/1998
WO WO-9907844 2/1999

OTHER PUBLICATIONS

Raper, Surgery, 137(5):487-492, 2005.*
Kimmelman, BMJ, 220:79-82, 2003.*
Juengst, BMJ, 326:1410-1411, 2003.*
Wolf, Nat. Biotechnol. 20:768-769, 2002.*
Rosenberg et al, Science 287:1751, 2000.*
Donsante et al, Science, 317:477, 2007.*
Couzin et al, Science 307:1028, 2005.*
Touchette, Nat. Med. 2(1):7-8, 1996.*
Rutanan et al, Gene Therapy 12:980-987,2005.*
Thomas et al, Progress and Problems With the Use of Viral Vectors for Gene Therapy, Nature, 346 I May 2003, vol. 4, pp. 346-358.*
Russell, S. J., Replicating Vectors for Gene Therapy of Cancer: Risks, Limitations and Prospects, European J Cancer, 1994, vol. 30A (8), pp. 1165-1171.*
Check, E, Cancer fears cast doubts on future of gene therapy, Nature,2003, Vo1421, p. 678.*
Guo et al, Protein tolerance to random amino acid change, PNAS, 2004, vol. 101 (25), pp. 9205-9210.*
Lesk et al, Prediction of Protein Function from Protein Sequence and Structure, p. 27 and 28, downloaded Sep. 16, 2007.*
Murat Kasap, Phylogenetic Analysis of Vascular Endothelial Growth Factor Diversity, Turk J Biol 29 (2005) 217-227.*
Leppanen et al, Structural determinants of vascular endothelial growth factor-D receptor binding and specificity, Blood, Feb. 3, 2011 _vol. 117, No. 5, 1507-1515.*
Enholm, et al., "Vascular endothelial growth factor C, a growth factor for lymphatic endothelial cells," Trends in Cardiovascular Med. 8:292 297 (1998).
Enholm, et al., "Comparison of VEGF, VEGF B, VEGF C and Ang 1 mRNA regulation by serum, growth factors, oncoproteins and hypoxia," Oncogene 14:2475 2483 (1997).
Feldman, et al., "Perspectives of arterial gene therapy for the prevention of restenosis," Cardiovascular Research 32:194 207 (1996).

(Continued)

Primary Examiner — Maria Marvich
(74) *Attorney, Agent, or Firm* — Marshall, Gerstein & Borun LLP

(57) **ABSTRACT**

The present invention provides materials and methods for preventing stenosis or restenosis of a blood vessel using Vascular Endothelial Growth Factor C (VEGF-C) and/or Vascular Endothelial Growth Factor D (VEGF-D) genes or proteins.

OTHER PUBLICATIONS

- Ferrara, et al., "Clinical applications of angiogenic growth factors and their inhibitors," *Nature Med* 5:1359 64 (Dec. 1999).
GenBank Accession No. AJ000185 *Homo sapiens* mRNA for vascular endothelial growth factor D.
GenBank Accession No. AF014827 *Rattus norvegicus* vascular endothelial growth factor D (VEGF D) mRNA, complete cds.
GenBank Accession No. MMU73620 *Mus musculus* VEGF C mRNA, complete cds.
GenBank Accession No. CCY15837 *Coturnix coturnix* mRNA for vascular endothelial growth factor C.
GenBank Accession No. D89628 *Mus musculus* mRNA for vascular endothelial growth factor D, complete cds.
GenBank Accession No. X94216 *H. sapiens* mRNA for VEGF C protein.
Gnatenko, et al., "Characterization of recombinant adeno associated virus 2 as a vehicle for gene delivery and expression into vascular cells," *J. Investig. Med.* 45:87 89 (1997).
Grosskreutz, et al., "Vascular endothelial growth factor induced migration of vascular smooth muscle cells in vitro," *Microvasc. Res.* 58(2):128 136 (1999).
Hu, et al., "A novel regulatory function of proteolytically cleaved VEGF 2 for vascular endothelial and smooth muscle cells," *FASEB J.* 11:498 504 (1997).
International Search Report for PCT/US99/24054.
Isner, et al., "Arterial gene therapy for therapeutic angiogenesis in patients with peripheral artery disease," *Circulation* 91:2687 2692 (1995).
Isner, et al., "Arterial gene therapy for restenosis," *Human Gene Therapy* 7:989 1011 (May 1996).
Jeltsch, et al., "Hyperplasia of lymphatic vessels in VEGF C transgenic mice," *Science* 276:1423 1425 (1997).
Joukov, et al., "Vascular endothelial growth factors VEGF B and VEGF C," *J. Cell Physiol* 173:211 215 (1997).
Joukov, et al., "Proteolytic processing regulates receptor specificity and activity of VEGF C," *EMBO J.* 16(13):3898 3911 (1997).
Joukov, et al., "A recombinant mutant vascular endothelial growth factor C that has lost vascular endothelial growth factor receptor 2 binding, activation, and vascular permeability activities," *J. Biol. Chem.* 273(12):6599 6602 (Mar. 1998).
Joukov, et al., "A novel vascular endothelial growth factor, VEGF C, is a ligand for the Flt4 (VEGFR 3) and KDR (VEGFR 2) receptor tyrosine kinases," *EMBO J.* 15:290 298 (1996).
Jussila, et al., "Lymphatic endothelium and Kaposi's sarcoma spindle cells detected by antibodies against the vascular endothelial growth factor receptor 3," *Cancer Res.* 58(8):1599 604 (1998).
Kagan, et al., "Mediators of restenosis," *Surgical Clinics of North America* 78:481 500 (Jun. 1998).
Kim, et al., "Minimal requirements for lentivirus vector based on human immunodeficiency virus type 1," *J. Virol.* 72(1):811 816 (Jan. 1998).
Kingsman et al., "A new generation of gene therapy vectors," *Scrip Magazine* 43 46 (Oct. 1998).
Ark Therapeutics Group PLC—Research Update, Ark's VEGF D gene-based medicine to commence Phase I/IIa development in refractory angina, Aug. 26, 2009.
Ark Therapeutics Group PLC—Trinam Phase III Study Enrolls First Patient, Trinam® Phase III Study Enrolls First Patient, May 21, 2009.
Ark Therapeutics Group PLC—Trinam Phase III trial to commence, Ark completes potency test qualification enabling Trinam® Phase III trial to commence, Jan. 8, 2009.
Ark Therapeutics Ltd., Adenovirus Vascular Endothelial Growth Factor (VEGF) Therapy in Vascular Access—Novel Trinam Against Control Evidence (AdV-Vantage), <<http://clinicaltrials.gov/ct2/show/record/NCT00895479>> Sep. 15, 2009.
Bell et al., Human epidermal growth factor precursor: cDNA sequence, expression in vitro and gene organization. *Nucl. Acids Res.* 14(21): 8427-46 (1986).
Bhardwaj et al., VEGF-A, VEGF-D and VEGF-D(DeltaNDeltaC) induced intimal hyperplasia in carotid arteries. *Eur. J. Clin. Invest.* 35(11): 669-76 (2005).
Chicago Tribune, May 10, 2002, Section 3, p. 4.
Corson et al., Fibrillin binds calcium and is coded by cDNAs that reveal a multidomain structure and alternatively spliced exons at the 5' end. *Genomics*, 17: 476-84 (1993).
Dangas et al., Restenosis: Repeat Narrowing of a Coronary Artery: Prevention and Treatment. *Circulation*, 105: 2586-7 (2002).
Kaipainen et al., Expression of the fms-like tyrosine kinase 4 gene becomes restricted to lymphatic endothelium during development. *Proc. Natl. Acad. Sci. USA.* 92: 3566-70 (1995).
Kingsley, The TGF-beta superfamily: Newmembers, new receptors, and new genetic tests of function in different organisms. *Genes & Development*, 8(2): 133-46 (1994).
Lawson, New Directions in Dialysis Access: Genes, Cells, Wraps . . . Stents, Struts, PTFE and Plastic presentation notes.
Losordo et al., Phase 1/2 placebo-controlled, double-blind, dose-escalating trial of myocardial vascular endothelial growth factor 2 gene transfer by catheter delivery in patient with chronic myocardial ischemia. *Circulation*, 105: 2012-8 (2002).
Massague, The transforming growth factor-beta family. *Annu. Rev. Cell. Biol.* 6: 597-641 (1990).
Parfyonova et al., Plasminogen activators in vascular remodeling and angiogenesis. *Biochemistry (Moscow)*, 67(1): 119-34 (2002).
Rissanen et al., Current status of cardiovascular gene therapy. *Molec. Ther.* 15(7): 1233-47 (2007).
Rissanen et al., VEGF-D is the strongest angiogenic and lymphangiogenic effector among VEGFs delivered into skeleton muscle via adenoviruses. *Circ. Res.* 92: 1098-106 (2003).
Rutanan et al., Adenoviral catheter-mediated intramyocardial gene transfer using the mature form of vascular endothelial growth factor-D induces transmural angiogenesis in porcine heart. *Circulation*, 209: 1029-35 (2004).
Saaristo et al., Vascular endothelial growth factor-C gene therapy restores lymphatic flow across incision wounds. *FASEB J. Sep.* 10, 2004.
Vale et al., Randomized, single-blind, placebo-controlled pilot study of catheter-based myocardial gene transfer for therapeutic angiogenesis using left ventricular electromechanical mapping in patients with chronic myocardial ischemia. *Circulation*, 103: 2138-43 (2001).
Anderson, Human gene therapy. *Nature*, 392: 25-30 (1998).
Crystal, Transfer of genes to humans: Early lessons and obstacles to success. *Science*, 270: 404-10 (1995).
Deonarain et al., Ligand-targeted receptor-mediated vectors for gene delivery. *Exp. Opin. Ther. Patents*, 8(1): 53-69 (1998).
Eck et al., Gene-based therapy. Goodman & Gilman's The Pharmacological Basis of Therapeutics, 9th Edition, McGraw Hill: 77-101 (1996).
Friedmann, Principles for human gene therapy studies. *Science*, 287(5461): 2163-5 (2000).
Hiltunen et al., Intravascular adenovirus-mediate VEGF-C gene transfer reduces neointima formation in balloon-denuded rabbit aorta. *Circulation*, 102: 2262-8 (2000).
Miller et al., Targeted vectors for gene therapy. *FASEB*, 9: 190-9 (1995).
Ngo, Computational complexity protein structure prediction and the Levinthal paradox in the protein folding problem and tertiary structure prediction. Merz et al., (Eds.), Birkhauser Boston: Boston, MA, pp. 433 and 492-495 (1994).
Rosenberg et al., Gene Therapist, Heal Thyself. *Science*. 287: 1751 (2000).
Rudinger Characteristics of amino acids as components of a peptide hormone sequence in Peptide Hormones, Parsons (Ed.), University Park Press: Baltimore, MD, pp. 1-7 (1976).
Touchette et al., Gene therapy: Not ready for prim time. *Nat. Med.* 2(1): 7-8 (1996).
Turunen et al., Gene therapy for angiogenesis, restenosis, and related diseases. *Exp. Gerontol.* 43(4): 567-74 (1999).
Verma et al., Gene therapy-promises, problems and prospects. *Nature*, 389: 239-42 (1997).
Verma, Gene therapy: Beyond 2000. *Mol. Ther.* 1: 493 (2000).
Witzenbichler et al., Vascular endothelial growth factor-C (VEGF-C/VEGF-2) promotes angiogenesis in the setting of tissue ischemia. *Am. J. Pathol.* 153(2): 381-94 (1998).

- Achen, M.G. et al., "Vascular endothelial growth factor D (VEGF D) is a ligand for the tyrosine kinases VEGF receptor 2 (Flk1) and VEGF receptor 3 (Flt4)," *Proc. Natl. Acad. Sci. USA* 95(2):548 553 (Jan. 1998).
- Alitalo et al., "Vascular Endothelial Growth Factors B and C and Receptors Involved in Angiogenesis," German American Academic Council Foundation (GAAC)/ Stiftung Deutsch Amerikanisches Akademisches Konzil (DAAK), 2nd Symposium on Current Problems in Molecular Medicine: The Role of Cytokines in Human Disease, Nov. 17 20, 1996, Ringberg Castle, Germany, p. 1 (Abstract).
- Asahara, et al., "Accelerated restitution of endothelial integrity and endothelium dependent function after phVEGF165 gene transfer," *Circulation* 94:3291 3302 (1996).
- Asahara, et al., "Local delivery of vascular endothelial growth factor accelerates reendothelialization and attenuates intimal hyperplasia in balloon injured rat carotid artery," *Circulation* 91:2793 2801 (1995).
- Barr, et al., "Efficient catheter mediated gene transfer into the heart using replication defective adenovirus," *Gene Ther.* 1:51 58 (1994).
- Boshart, et al., "A very strong enhancer is located upstream of an immediate early gene of human cytomegalovirus," *Cell* 41:521 530 (Jun. 1985).
- Callow, et al., "Vascular permeability factor accelerates endothelial regrowth following balloon angioplasty," *Growth Factors* 10:223 228 (1994).
- Camenzind et al., "Use of Locally Delivered Conventional Drug Therapies," *Semin Intervent Cardiol* 1:67 76 (1996).
- Cao, et al., "Vascular endothelial growth factor C induces angiogenesis in vivo," *Proc. Natl. Acad. Sci.* 95:14389 14394 (1998).
- Cerek, et al., "Growth factors in pathogenesis of coronary arterial restenosis," *Am. J. Cardiol.* 68:24C 33C (Nov. 1991).
- Chang, et al., "Gene therapy for vascular proliferative disorders," *Semin. Intervent. Cardiol.* 1:185 193 (1996).
- Darius, et al., "Lokale Medikamentengabe und Gentherapie," *Herz* 22:347 54 (1997).
- Davis, et al., "Direct gene transfer into skeletal muscle in vivo: factors affecting efficiency of transfer and stability of expression," *Hum. Gene Ther.* 4:151 9 (1993).
- Debbas, et al., "Stenting within a stent: Treatment, for repeat in stent restenosis in a venous graft," *American Heart Journal* 133:460 468 (Apr. 1997).
- De Meyer, et al., "Mechanisms of neointima formation lessons from experimental models," *Vasc. Med.* 2:179 189 (1997).
- DeYoung, et al., "Gene therapy for restenosis: Are we ready?," *Circ. Res.* 82:306 313 (1998).
- Dignam, et al., "Balbiani ring 3 in *Chironomus tentans* encodes a 185 kDa secretory protein which is synthesized throughout the fourth larval instar," *Gene* 88:133 140 (1990).
- Korhonen, et al., "Endothelial specific gene expression directed by the tie gene promoter in vivo," *Blood* 86(5):1828 1835 (Sep. 1995).
- Kukk, et al., "VEGF C receptor binding and pattern of expression with VEGFR 3 suggests a role in lymphatic vascular development," *Development* 122:3829 3839 (1996).
- Laitinen, et al., "VEGF gene transfer reduces intimal thickening via increased production of nitric oxide in carotid arteries," *Hum. Gene Ther* 8:1737 1744 (Oct. 1997).
- Laitinen, et al., "Adenovirus mediated gene transfer to lower limb artery of patients with chronic critical leg ischemia," *Hum. Gene Ther.* 9:1481 1486 (Jul. 1998).
- Laitinen, et al., "Adventitial gene transfer to arterial wall," *Pharmacol Res* 37:251 254 (1998).
- Lambert, et al., "Local drug delivery catheters: functional comparison of porous and microporous designs," *Coron. Artery Dis.* 4:469 475 (1993).
- Lee, et al., "Vascular endothelial growth factor related protein: A ligand and specific activator of the tyrosine kinase receptor Flt4," *Proc. Natl. Acad. Sci. USA* 93:1988 1992 (1996).
- Lehner, et al., "Comparative sequence analysis of human cytomegalovirus strains," *J. Clin. Microbiol.* 29:2494 2502 (Nov. 1991).
- Libby, "Gene therapy of restenosis: Promise and Perils," *Circ. Res.* 82:404 406 (1998).
- Lincoff, et al., "Local drug delivery for the prevention of restenosis: Fact, Fancy, and Future," *Circulation* 90:2070 2084 (1994).
- Lymboussaki, et al., "Expression of the vascular endothelial growth factor C receptor VEGFR 3 in lymphatic endothelium of the skin and in vascular tumors," *Am J. Path* 153:395 403 (Aug. 1998).
- Marchiò, et al., "Vascular endothelial growth factor C stimulates the migration and proliferation of *Kaposi's sarcoma* cells," *J. Biol. Chem.* 274:27617 27622 (Sep. 1999).
- Mazur, et al., "Coronary restenosis and gene therapy," *Texas Heart Institute Journal* 21:104 111 (1994).
- Morishita, et al., "Contribution of a vascular modulator, hepatocyte growth factor (HGF), to the pathogenesis of cardiovascular disease," *J. Atherosclerosis and Thrombosis* 4(3):128 134 (1998).
- Mulligan, "The basic science of gene therapy," *Science* 260:926 932 (May 1993).
- Narins, et al., "A call for provisional stenting: The balloon in back," *Circulation* 97:1298 1305 (1998).
- Oh, et al., "VEGF and VEGF C: Specific induction of angiogenesis and lymphangiogenesis in the differentiated avian chorioallantoic membrane," *Dev. Biol.* 188:96 109 (1997).
- Ohno, et al., "Gene therapy for vascular smooth muscle cell proliferation after arterial injury," *Science* 265:781 784 (Aug. 1994).
- Paavonen et al., "Chromosomal Localization and Regulation of Human Vascular Endothelial Growth Factors B and C (VEGF B and VEGF C)," IX International Vascular Biology Meeting, Seattle, Washington, Sep. 4-8, 1996, p. 76 (Abstract 299).
- Paavonen et al., "Novel Human Vascular Endothelial Growth Factor Genes VEGF B and VEGF C Localize to Chromosomes 11q13 and 4q34, Respectively," *Circulation* 93(6):1079 1082 (Mar. 15, 1996).
- Paulsson, et al., "The Balbiani ring 3 gene in *Chironomus tentans* has diverged repetitive structure split by many introns," *J. Mol. Biol.* 211:331 349 (1990).
- Pepper, et al., "Vascular endothelial growth factor (VEGF) C synergizes with basic fibroblast growth factor and VEGF in the induction of angiogenesis in vitro and alters endothelial cell extracellular proteolytic activity," *J. Cell Physiol.* 177:439 452 (1998).
- Quantin, et al., "Adenovirus as an expression vector in muscle cells in vivo," *Proc. Natl. Acad. Sci. USA* 89:2581 2584 (Apr. 1992).
- Riessen, et al., "Arterial gene transfer using pure DNA applied directly to a hydrogel coated angioplasty balloon," *Human Gene Therapy* 4:749 758 (1993).
- Riessen, et al., "Prospects for site specific delivery of pharmacologic and molecular therapies," *J. Am. Coll. Cardiol.* 23:1234 1244 (Apr. 1994).
- Rosenfeld, et al., "In vivo transfer of the human cystic fibrosis transmembrane conductance regulator gene to the airway epithelium," *Cell* 68:143 155 (Jan. 1992).
- Salven, et al., "Vascular endothelial growth factors VEGF B and VEGF C are expressed in human tumors," *Am. J. Pathol.* 153:103 108 (1998).
- Sambrook et al., *Molecular Cloning: A Laboratory Manual*, 2nd ed., Cold Spring Harbor Laboratory Press, § 9.47 9.51 (1989).
- Schwartz, "The vessel wall reaction in restenosis," *Semin Intervent Cardiol* 2:83 88 (1997).
- Serruys, et al., "Heparin coated Palmaz Schatz stents in human coronary arteries," *Circulation* 93:412 422 (1996).
- Shih, et al., "Focal accumulation of an apolipoprotein B based synthetic oligopeptide in the healing rabbit arterial wall," *Proc Natl. Acad. Sci. USA* 87:1436 1440 (Feb. 1990).
- Steg, et al., "Arterial gene transfer to the rabbit endothelial and smooth muscle cells using percutaneous delivery of an adenoviral vector," *Circulation* 90:1648 1656 (1994).
- Steg, et al., "Reduction of restenosis after angioplasty in a atheromatous rabbit model by suicide gene therapy," *Circulation* 96:408 411 (1997).
- Stratford Perricaudet, et al., "Widespread long term gene transfer to mouse skeletal muscles and heart," *J. Clin. Invest.* 90:626 630 (Aug. 1992).
- Turunen, et al., "Efficient adventitial gene delivery to rabbit carotid artery with cationic polymer plasmic complexes," *Gene Therapy* 6:6 11 (1999).

Van Belle, et al., "Passivation of metallic stents after arterial gene transfer of phVEGF165 inhibits thrombus formation and intimal thickening," *J. Am. Coll. Cardiol.* 29:1371 1379 (May 1997).

Valtola, et al., "VEGFR 3 and its ligand VEGF C are associated with angiogenesis in breast cancer," *Am. J. Pathol.* 154:1381 1390 (May 1999).

Wang, et al., "Signal transduction in human hematopoietic cells by vascular endothelial growth factor related protein, a novel ligand for the FLT4 receptor," *Blood* 90(9):3507 15 (1997).

Wartiovaara, et al., "Peripheral blood platelets express VEGF C and VEGF which are released during platelet activation," *Thromb. Haemost.* 80:171 175 (1998).

Wilensky, et al., "Methods and devices for local drug delivery in coronary and peripheral arteries," *Trends Cardiovasc. Med.* 3:163 170 (1993).

Willard, et al., "Genetic modification of the vessel wall," *Circulation* 89:2190 2197 (1994).

Witzenbichler, et al., "Bioactivity of vascular endothelial growth factor 2 (=VEGF C) in vitro and in vivo following intraarterial administration of recombinant protein or intravascular gene transfer in a rabbit ischemic hindlimb model," *Eur Heart J.* 18:suppl. p. 5 (1997).

Wolinsky, et al., "Use of a perforated balloon catheter to deliver concentrated heparin into the wall of the normal canine artery," *J. Am. Coll. Cardiol.* 15:475 481 (Feb. 1990).

Ylä Herttuala, et al., "Biochemical composition of coronary arteries in Finnish children," *Arteriosclerosis* 6:230 236 (Mar./Apr. 1986).

Ylä Herttuala, "Gene therapy for cardiovascular diseases," *Ann Med* 28:89 93 (1996).

Ylä Herttuala, "Vascular gene transfer," *Curr Opin Lipidol* 8:72 76 (1997).

* cited by examiner

FIG. 1

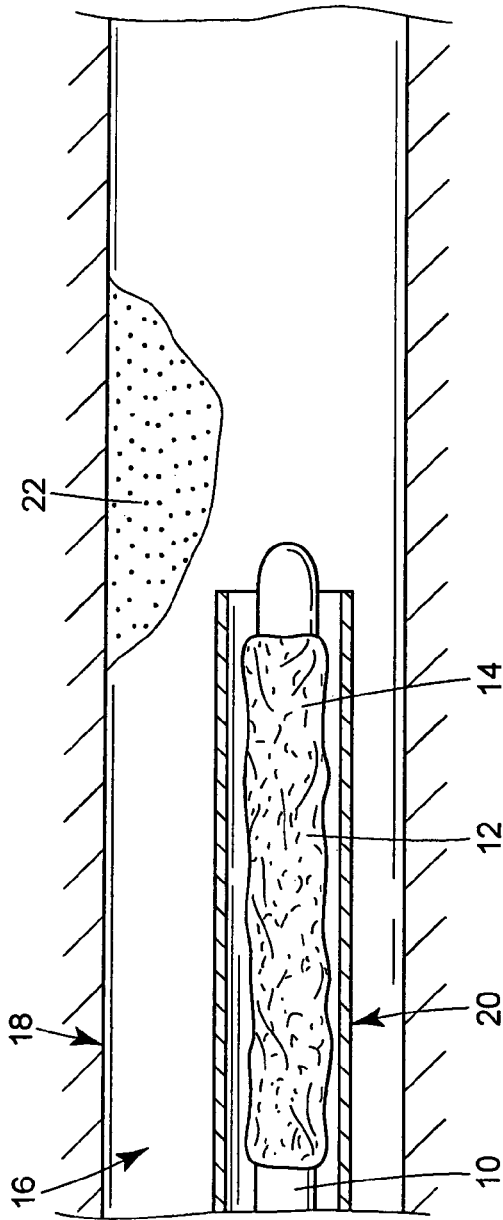

FIG. 4B

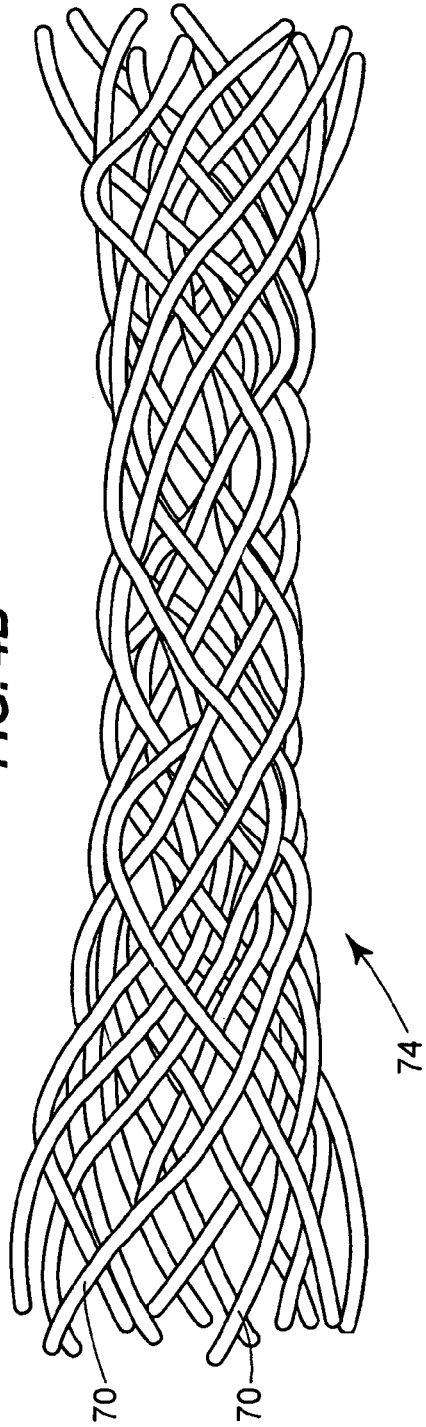

FIG. 2A

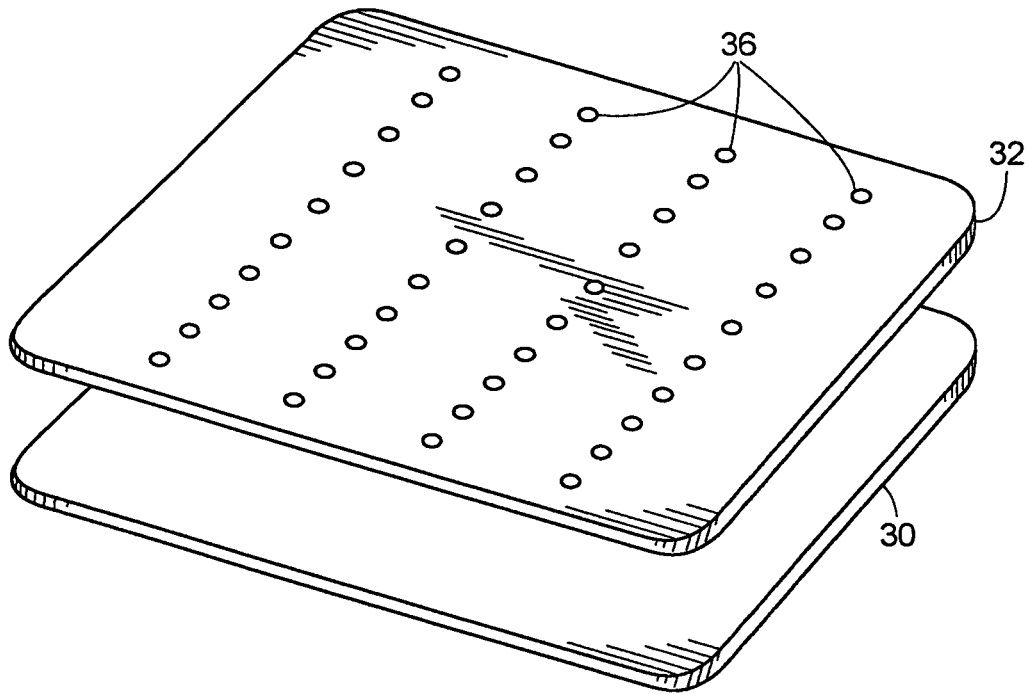

FIG. 2B

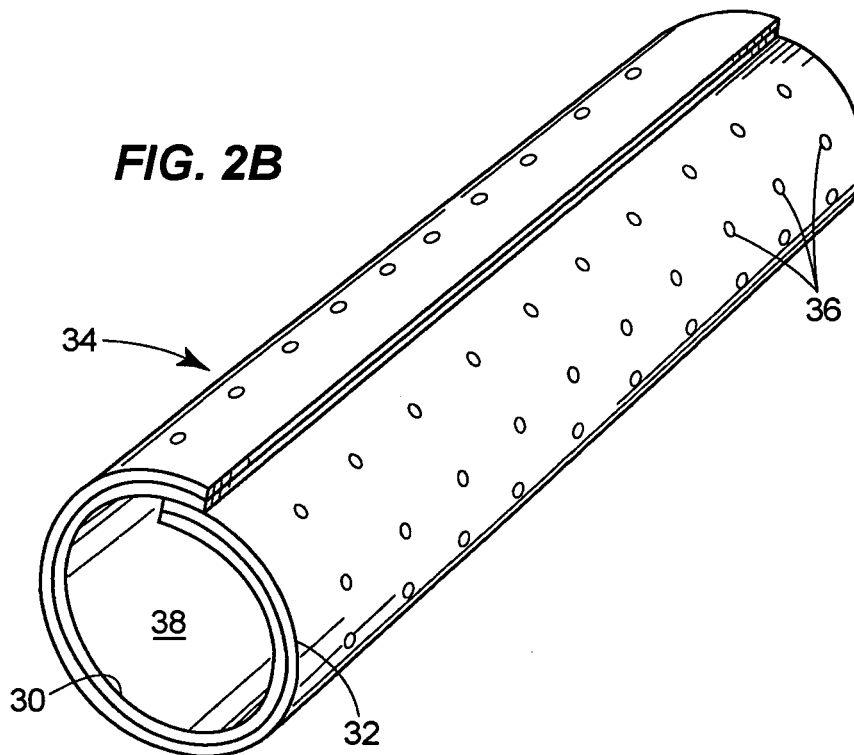

FIG. 3A

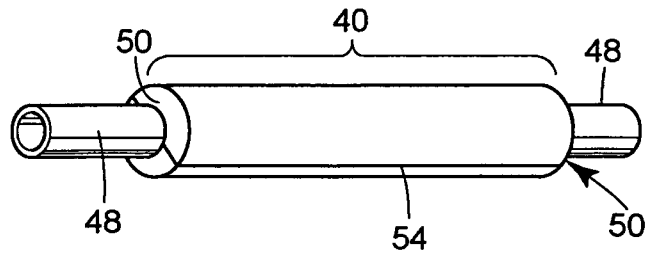

FIG. 3B

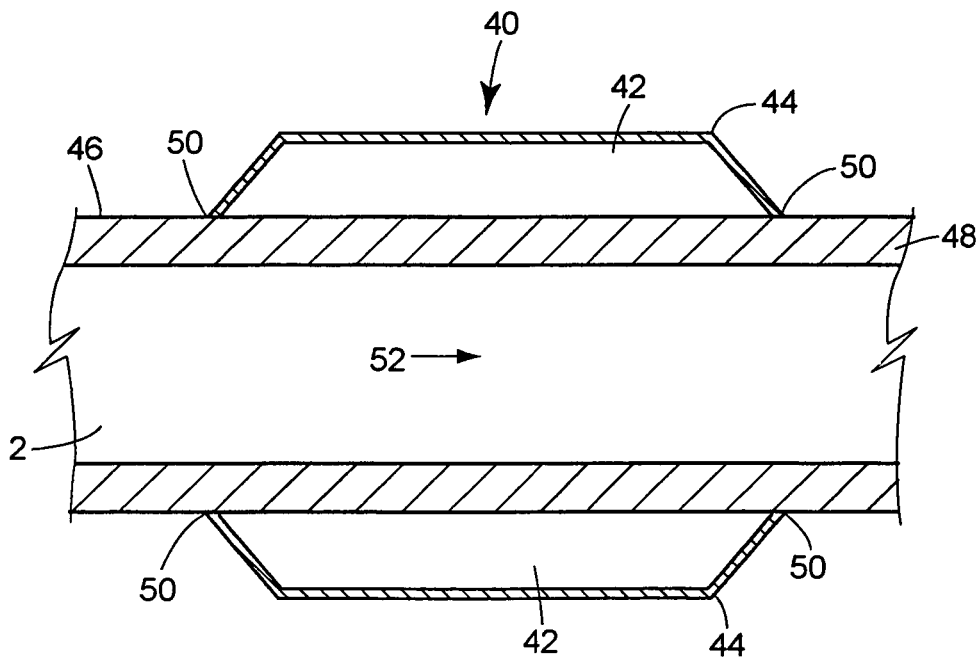
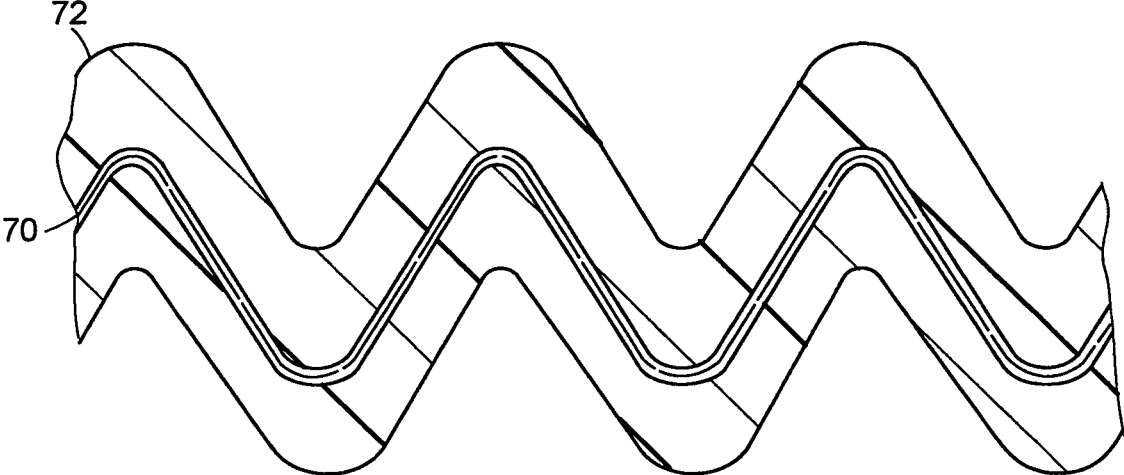

FIG. 4A



1

USE OF VEGF-D GENE TO PREVENT RESTENOSIS

This application is a continuation of U.S. patent application Ser. No. 09/427,657, filed Oct. 26, 1999, now U.S. Pat. No. 6,958,147, which claims the priority benefit of U.S. Provisional Application No. 60/105,587, filed Oct. 26, 1998. All priority applications are incorporated herein by reference.

FIELD OF THE INVENTION

The present invention provides materials and methods to prevent stenosis and restenosis of blood vessels, and relates generally to the field of cardiovascular medicine.

BACKGROUND OF THE INVENTION

Coronary artery disease constitutes a major cause of morbidity and mortality throughout the world, especially in the United States and Europe. Percutaneous transluminal coronary angioplasty (e.g., balloon angioplasty, with or without intracoronary stenting) is now a common and successful therapy for such disease, performed hundreds of thousands of times per year in the United States alone. However, restenosis occurs in as many as one-third to one-half of such revascularization procedures, usually within six months of the angioplasty procedure. The economic cost of restenosis has been estimated at \$2 billion annually in the United States alone. [Feldman et al., *Cardiovascular Research*, 32: 194-207 (1996), incorporated herein by reference.] Autopsy and atherectomy studies have identified intimal hyperplasia as the major histologic component of restenotic lesions. [Cerek et al., *Am. J. Cardiol.*, 68: 24C-33C (1991).]

Restenosis also remains a clinical concern in angioplasty that is performed in peripheral blood vessels. Likewise, stenosis is a clinical concern following transplantation of blood vessels (e.g., grafted veins and grafted artificial vessels) for cardiac bypass therapy or for treatment of peripheral ischemia or intermittent claudication, for example (e.g., above-knee femoro-popliteal arterial bypass grafts).

Mazur et al., *Texas Heart Institute Journal*, 21: 104-111 (1994) state that restenosis is primarily a response of the artery to the injury caused by percutaneous coronary angioplasty, which disrupts the intimal layer of endothelial cells and underlying smooth muscle cells of the media. The authors state that multiple growth factors secreted by platelets, endothelial cells, macrophages, and smooth muscle cells are mechanistically involved in the restenosis process, and that proliferation of smooth muscle cells constitutes a critical pathogenetic feature. According to the authors, this smooth muscle cell proliferation has proven refractory to mechanical and pharmacologic therapy. More recently, others have called into question whether smooth muscle cell proliferation is of penultimate importance in restenosis. See Libby, *Circ. Res.*, 82: 404-406 (1998).

Narins et al., *Circulation*, 97: 1298-1305 (1998) review the use of intracoronary stents and their benefits and limitations in preventing restenosis. Debbas et al., *American Heart Journal*, 133: 460-468 (1997) discuss stenting within a stent to treat in-stent restenosis.

Chang & Leiden, *Semin. Intervent. Cardiol.*, 1: 185-193 (1996), incorporated herein by reference, review somatic gene therapy approaches to treat restenosis. Chang and Leiden teach that replication-deficient adenoviruses comprise a promising and safe vector system for gene therapy directed toward prevention of restenosis, because such viruses can efficiently infect a wide variety of cell types,

2

including vascular smooth muscle cells; such viruses can be produced at high titers (e.g., 10^{10} - 10^{12} plaque forming units per milliliter); such viruses can accommodate a transgene insert of, e.g., 7-9 kilobases (kb) in size; such viruses can be delivered percutaneously through standard catheters; and such viruses do not integrate into the host genome. Both Chang & Leiden and Feldman et al., supra, also review cytotoxic and cytostatic gene therapy approaches, designed to kill or arrest proliferating vascular smooth muscle cells thought to be responsible for neointimal formations that characterize restenosis.

Riessen & Isner, *J. Am. Coll. Cardiol.*, 23:1234-1244 (1994), incorporated by reference, review devices for intravascular drug delivery and vectors for intravascular gene therapy.

Cerek et al., *Am. J. Cardiol.*, 68: 24C-33C (1991) suggest prevention of restenosis by inhibiting growth-factor-mediated healing of arterial injury. Potential roles of platelet-derived growth factor (PDGF), thrombospondin, insulin-like growth factor 1 (IGF-1), fibroblast growth factors (FGF's), transforming growth factor alpha (TGF- α) and beta (TGF- β), epidermal growth factor (EGF) are discussed.

Isner & Asahara, International Patent Publication No. WO 98/19712, incorporated herein by reference, suggest treating injured blood vessels and accelerating reendothelialization following angioplasty by isolating a patient's endothelial progenitor cells and re-administering such cells to the patient. The authors suggest that the effectiveness of using an angiogenesis-promoting growth factor, such as vascular endothelial growth factor (VEGF) or basic fibroblast growth factor (bFGF), may be limited by the lack of endothelial cells on which the VEGF or bFGF will exert its effect.

Martin et al., International Patent Publication No. WO 98/20027 suggest the use of VEGF gene or protein to treat or prevent stenosis or restenosis of a blood vessel. The authors suggest that any beneficial effect of VEGF arises from a different mechanism of action than the mechanism underlying an activity of VEGF related to stimulating re-endothelialization in cases where the endothelium has been damaged.

Callow et al., *Growth Factors*, 10: 223-228 (1994) state that intravenous injection of vascular permeability factor (a.k.a. VEGF) into rabbits that had been subjected to balloon angioplasty-induced endothelial denudation resulted in increased regeneration of endothelium compared to a control. The authors also stated that basic fibroblast growth factor (bFGF) is effective at promoting re-endothelialization, but that such re-endothelialization is accompanied by increases in neointimal lesion size.

Asahara et al., *Circulation*, 94: 3291-3302 (Dec. 15, 1996) state that local, percutaneous catheter delivery of a CMV-human-VEGF₁₆₅ transgene achieved accelerated re-endothelialization in balloon-injured rabbits, and resulted in diminished intimal thickening. In a report by a related group of authors, Van Belle et al., *J. Am. Coll. Cardiol.*, 29:1371-1379 (May, 1997) state that stent endothelialization was accelerated by delivery of a CMV-human-VEGF₁₆₅ transgene and was accompanied by attenuation of intimal thickening.

Morishita et al., *J. Atherosclerosis and Thrombosis*, 4(3): 128-134 (1998) state that hepatocyte growth factor (HGF) has a mitogenic activity on human endothelial cells more potent than VEGF, and hypothesized that HGF gene therapy may have potential therapeutic value for the treatment of cardiovascular diseases such as restenosis after angioplasty. Morishita et al. also state that there is little knowledge about growth factors that stimulate only endothelial cells, but not vascular smooth muscle cells.

DeYoung & Dichek, *Circ. Res.*, 82: 306-313 (1998) state that VEGF gene delivery does not currently appear destined for application to human coronary restenosis, and that two independent studies suggest that VEGF delivery may actually worsen arterial intimal hyperplasia.

Brown et al., U.S. Pat. No. 5,795,898, suggest using an inhibitor of PDGF, FGF, EGF, or VEGF signaling to suppress accelerated atherogenesis involved in restenosis of coronary vessels or other arterial vessels following angioplasty.

The foregoing discussion demonstrates that a long-felt need continues to exist for improvements to angioplasty materials and/or methods, and/or for adjunct therapies, to reduce instances of restenosis.

SUMMARY OF THE INVENTION

The present invention addresses long-felt needs in the field of medicine by providing materials and methods for the prevention of stenosis or restenosis in mammalian blood vessels.

For example, the invention provides a method of treating a mammalian subject to prevent stenosis or restenosis of a blood vessel, comprising the step of administering to a mammalian subject in need of treatment to prevent stenosis or restenosis of a blood vessel a composition comprising a polynucleotide, the polynucleotide comprising a nucleotide sequence that encodes a vascular endothelial growth factor C (VEGF-C) polypeptide. In a preferred embodiment, the subject is a human subject.

While it is contemplated that the VEGF-C polynucleotide could be administered purely as a prophylactic treatment to prevent stenosis, it is contemplated in a preferred embodiment that the polynucleotide be administered shortly before, and/or concurrently with, and/or shortly after a percutaneous transluminal coronary angioplasty procedure, for the purpose of preventing restenosis of the subject vessel. In another preferred embodiment, the polynucleotide is administered before, during, and/or shortly after a bypass procedure (e.g., a coronary bypass procedure), to prevent stenosis or restenosis in or near the transplanted (grafted) vessel, especially stenosis at the location of the graft itself. In yet another embodiment, the polynucleotide is administered before, during, or after a vascular transplantation in the vascular periphery that has been performed to treat peripheral ischemia or intermittent claudication. By prevention of stenosis or restenosis is meant prophylactic treatment to reduce the amount/severity of, and/or substantially eliminate, the stenosis or restenosis that frequently occurs in such surgical procedures. The polynucleotide is included in the composition in an amount and in a form effective to promote expression of a VEGF-C polypeptide in a blood vessel of the mammalian subject, thereby preventing stenosis or restenosis of the blood vessel.

In a preferred embodiment, the mammalian subject is a human subject. For example, the subject is a person suffering from coronary artery disease that has been identified by a cardiologist as a candidate who could benefit from a therapeutic balloon angioplasty (with or without insertion of an intravascular stent) procedure or from a coronary bypass procedure. Practice of methods of the invention in other mammalian subjects, especially mammals that are conventionally used as models for demonstrating therapeutic efficacy in humans (e.g., primate, porcine, canine, or rabbit animals), also is contemplated.

For the practice of methods of the invention, the term "VEGF-C polypeptide" is intended to include any polypeptide that has a VEGF-C or VEGF-C analog amino acid sequence (as defined elsewhere herein in greater detail) and

that possesses in vivo restenosis-reducing effects of human VEGF-C, which effects are demonstrated herein by way of example in a rabbit model. The term "VEGF-C polynucleotide" is intended to include any polynucleotide (e.g., DNA or RNA, single- or double-stranded) comprising a nucleotide sequence that encodes a VEGF-C polypeptide. Due to the well-known degeneracy of the genetic code, there exist multiple VEGF-C polynucleotide sequences that encode any selected VEGF-C polypeptide.

For treatment of humans, VEGF-C polypeptides with an amino acid sequence of a human VEGF-C are highly preferred, and polynucleotides comprising a nucleotide sequence of a human VEGF-C cDNA are highly preferred. By "human VEGF-C" is meant a polypeptide corresponding to a naturally occurring protein (prepro-protein, partially-processed protein, or fully-processed mature protein) encoded by any allele of the human VEGF-C gene, or a polypeptide comprising a biologically active fragment of a naturally-occurring mature protein. By way of example, a human VEGF-C comprises a continuous portion of the amino acid sequence set forth in SEQ ID NO: 2 sufficient to permit the polypeptide to bind and stimulate VEGFR-2 and/or VEGFR-3 phosphorylation in cells that express such receptors. A polypeptide comprising amino acids 131-211 of SEQ ID NO: 2 is specifically contemplated. For example, polypeptides having an amino acid sequence comprising a continuous portion of SEQ ID NO: 2, the continuous portion having, as its amino terminus, an amino acid selected from the group consisting of positions 30-131 of SEQ ID NO: 2, and having, as its carboxyl terminus, an amino acid selected from the group consisting of positions 211-419 of SEQ ID NO: 2 are contemplated. As explained elsewhere herein in greater detail, VEGF-C biological activities, especially those mediated through VEGFR-2, increase upon processing of both an amino-terminal and carboxyl-terminal pro-peptide. Thus, an amino terminus selected from the group consisting of positions 102-131 of SEQ ID NO: 2 is preferred, and an amino terminus selected from the group consisting of positions 103-113 of SEQ ID NO: 2 is highly preferred. Likewise, a carboxyl terminus selected from the group consisting of positions 211-227 of SEQ ID NO: 2 is preferred. As stated above, the term "human VEGF-C" also is intended to encompass polypeptides encoded by allelic variants of the human VEGF-C characterized by the sequences set forth in SEQ ID NOS: 1 & 2.

Moreover, since the therapeutic VEGF-C is to be administered as recombinant VEGF-C or indirectly via somatic gene therapy, it is within the skill in the art to make and use analogs of human VEGF-C (and polynucleotides that encode such analogs) wherein one or more amino acids have been added, deleted, or replaced with other amino acids, especially with conservative replacements, and wherein the anti-restenosis biological activity has been retained. Analogs that retain anti-restenosis VEGF-C biological activity are contemplated as VEGF-C polypeptides for use in the present invention. In a preferred embodiment, analogs having 1, 2, 3, 4, 5, 6, 7, 8, 9, 10, 11, 12, 25 13, 14, 15, 16, 17, 18, 19, 20, 21, 22, 23, 24, or 25 such modifications and that retain anti-restenosis VEGF-C biological activity are contemplated as VEGF-C polypeptides for use in the present invention. Polynucleotides encoding such analogs are generated using conventional PCR, site-directed mutagenesis, and chemical synthesis techniques.

Also contemplated as VEGF-C polypeptides are non-human mammalian or avian VEGF-C polypeptides and polynucleotides. By "mammalian VEGF-C" is meant a polypeptide corresponding to a naturally occurring protein (prepro-protein, partially-processed protein, or fully-processed

mature protein) encoded by any allele of a VEGF-C gene of any mammal, or a polypeptide comprising a biologically active fragment of a mature protein. The term "mammalian VEGF-C polypeptide" is intended to include analogs of mammalian VEGF-C's that possess the in vivo restenosis-reducing effects of the mammalian VEGF-C. The fact that gene therapy using a transgene encoding human VEGF-C is effective to prevent restenosis in a rabbit model is evidence of the inter-species therapeutic efficacy of VEGF-C proteins.

Irrespective of which VEGF-C polypeptide is chosen, the VEGF-C polynucleotide preferably comprises a nucleotide sequence encoding a secretory signal peptide fused in-frame with the VEGF-C polypeptide sequence. The secretory signal peptide directs secretion of the VEGF-C polypeptide by the cells that express the polynucleotide, and is cleaved by the cell from the secreted VEGF-C polypeptide. For example, the VEGF-C polynucleotide could encode the complete prepro-VEGF-C sequence set forth in SEQ ID NO: 2; or could encode the VEGF-C signal peptide fused in-frame to a sequence encoding a fully-processed VEGF-C (e.g., amino acids 103-227 of SEQ ID NO: 2) or VEGF-C analog. Moreover, there is no requirement that the signal peptide be derived from VEGF-C. The signal peptide sequence can be that of another secreted protein, or can be a completely synthetic signal sequence effective to direct secretion in cells of the mammalian subject.

In one embodiment, the VEGF-C polynucleotide of the invention comprises a nucleotide sequence that will hybridize to a polynucleotide that is complementary to the human VEGF cDNA sequence specified in SEQ ID NO: 1 under the following exemplary stringent hybridization conditions: hybridization at 42° C. in 50% formamide, 5X SSC, 20 mM Na—PO₄, pH 6.8; and washing in 1X SSC at 55° C. for 30 minutes; and wherein the nucleotide sequence encodes a polypeptide that binds and stimulates human VEGFR-2 and/or VEGFR-3. It is understood that variation in these exemplary conditions occur based on the length and GC nucleotide content of the sequences to be hybridized. Formulas standard in the art are appropriate for determining appropriate hybridization conditions. See Sambrook et al., *Molecular Cloning: A Laboratory Manual* (Second ed., Cold Spring Harbor Laboratory Press, 1989) §§ 9.47-9.51.

In preferred embodiments, the VEGF-C polynucleotide further comprises additional sequences to facilitate the VEGF-C gene therapy. In one embodiment, a "naked" VEGF-C transgene (i.e., a transgene without a viral, liposomal, or other vector to facilitate transfection) is employed for gene therapy. In this embodiment, the VEGF-C polynucleotide preferably comprises a suitable promoter and/or enhancer sequence (e.g., cytomegalovirus promoter/enhancer [Lehner et al., *J. Clin. Microbiol.*, 29:2494-2502 (1991); Boshart et al., *Cell*, 41:521-530 (1985)]; Rous sarcoma virus promoter [Davis et al., *Hum. Gene Ther.*, 4:151 (1993)]; Tie promoter [Korhonen et al., *Blood*, 86(5): 1828-1835 (1995)]; or simian virus 40 promoter) for expression in the target mammalian cells, the promoter being operatively linked upstream (i.e., 5') of the VEGF-C coding sequence. The VEGF-C polynucleotide also preferably further includes a suitable polyadenylation sequence (e.g., the SV40 or human growth hormone gene polyadenylation sequence) operably linked downstream (i.e., 3') of the VEGF-C coding sequence. The polynucleotide may further optionally comprise sequences whose only intended function is to facilitate large-scale production of the vector, e.g., in bacteria, such as a bacterial origin of replication and a sequence encoding a selectable marker. However, in a preferred embodiment, such extraneous sequences are at least partially cleaved off prior to

administration to humans according to methods of the invention. One can manufacture and administer such polynucleotides to achieve successful gene therapy using procedures that have been described in the literature for other transgenes. See, e.g., Isner et al., *Circulation*, 91: 2687-2692 (1995); and Isner et al., *Human Gene Therapy*, 7: 989-1011 (1996); incorporated herein by reference in the entirety.

Any suitable vector may be used to introduce the VEGF-C transgene into the host. Exemplary vectors that have been described in the literature include replication-deficient retroviral vectors, including but not limited to lentivirus vectors [Kim et al., *J. Virol.*, 72(1): 811-816 (1998); Kingsman & Johnson, *Scrip Magazine*, October, 1998, pp. 43-46.]; adeno-associated viral vectors [Gnatenko et al., *J. Invest. Med.*, 45: 87-98 (1997)]; adenoviral vectors [See, e.g., U.S. Pat. No. 5,792,453; Quantin et al., *Proc. Natl. Acad. Sci. USA*, 89: 2581-2584 (1992); Stratford-Perricadet et al., *J. Clin. Invest.*, 90: 626-630 (1992); and Rosenfeld et al., *Cell*, 68: 143-155 (1992)]; Lipofectin-mediated gene transfer (BRL); liposomal vectors [See, e.g., U.S. Pat. No. 5,631,237 (Liposomes comprising Sendai virus proteins)]; and combinations thereof. All of the foregoing documents are incorporated herein by reference in the entirety. Replication-deficient adenoviral vectors constitute a preferred embodiment.

In embodiments employing a viral vector, preferred polynucleotides still include a suitable promoter and polyadenylation sequence as described above. Moreover, it will be readily apparent that, in these embodiments, the polynucleotide further includes vector polynucleotide sequences (e.g., adenoviral polynucleotide sequences) operably connected to the sequence encoding a VEGF-C polypeptide.

Thus, in one embodiment the composition to be administered comprises a vector, wherein the vector comprises the VEGF-C polynucleotide. In a preferred embodiment, the vector is an adenovirus vector. In a highly preferred embodiment, the adenovirus vector is replication-deficient, i.e., it cannot replicate in the mammalian subject due to deletion of essential viral-replication sequences from the adenoviral genome. For example, the inventors contemplate a method wherein the vector comprises a replication-deficient adenovirus, the adenovirus comprising the VEGF-C polynucleotide operably connected to a promoter and flanked on either end by adenoviral polynucleotide sequences.

The composition to be administered according to methods of the invention preferably comprises (in addition to the polynucleotide or vector) a pharmaceutically-acceptable carrier solution such as water, saline, phosphate-buffered saline, glucose, or other carriers conventionally used to deliver therapeutics intravascularly. Multi-gene therapy is also contemplated, in which case the composition optionally comprises both the VEGF-C polynucleotide/vector and another polynucleotide/vector selected to prevent restenosis. Exemplary candidate genes/vectors for co-transfection with VEGF-C transgenes are described in the literature cited above, including genes encoding cytotoxic factors, cytostatic factors, endothelial growth factors, and smooth muscle cell growth/migration inhibitors. As described in greater detail below, a VEGF-D transgene is a preferred candidate for co-administration with the VEGF-C transgene. Co-administration of a VEGF transgene also is specifically contemplated.

The "administering" that is performed according to the present method may be performed using any medically-accepted means for introducing a therapeutic directly or indirectly into the vasculature of a mammalian subject, including but not limited to injections; oral ingestion; intranasal or topical administration; and the like. In a preferred embodiment, administration of the composition comprising the

VEGF-C polynucleotide is performed intravascularly, such as by intravenous, intra-arterial, or intracoronary arterial injection.

In a highly preferred embodiment, the composition is administered locally, e.g., to the site of angioplasty or bypass. For example, the administering comprises a catheter-mediated transfer of the transgene-containing composition into a blood vessel of the mammalian subject, especially into a coronary artery of the mammalian subject. Exemplary materials and methods for local delivery are reviewed in Lincoff et al., *Circulation*, 90: 2070-2084 (1994); and Wilensky et al., *Trends Cardiovasc. Med.*, 3:163-170 (1993), both incorporated herein by reference. For example, the composition is administered using infusion-perfusion balloon catheters (preferably microporous balloon catheters) such as those that have been described in the literature for intracoronary drug infusions. See, e.g., U.S. Pat. No. 5,713,860 (Intravascular Catheter with Infusion Array); U.S. Pat. No. 5,087,244; U.S. Pat. No. 5,653,689; and Wolinsky et al., *J. Am. Coll. Cardiol.*, 15: 475-481 (1990) (Wolinsky Infusion Catheter); and Lambert et al., *Coron. Artery Dis.*, 4: 469-475 (1993), all of which are incorporated herein by reference in their entirety. Use of such catheters for site-directed somatic cell gene therapy is described, e.g., in Mazur et al., *Texas Heart Institute Journal*, 21: 104-111 (1994), incorporated herein by reference. In an embodiment where the VEGF-C transgene is administered in an adenovirus vector, the vector is preferably administered in a pharmaceutically acceptable carrier at a titer of 10^7 - 10^{13} viral particles, and more preferably at a titer of 10^9 - 10^{11} viral particles. The adenoviral vector composition preferably is infused over a period of 15 seconds to 30 minutes, more preferably 1 to 10 minutes.

For example, in patients with angina pectoris due to a single or multiple lesions in coronary arteries and for whom PTCA is prescribed on the basis of primary coronary angiogram findings, an exemplary protocol involves performing PTCA through a 7 F guiding catheter according to standard clinical practice using the femoral approach. If an optimal result is not achieved with PTCA alone, then an endovascular stent also is implanted. (A nonoptimal result is defined as residual stenosis of >30% of the luminal diameter according to a visual estimate, and B or C type dissection.) Arterial gene transfer at the site of balloon dilatation is performed with a replication-deficient adenoviral VEGF-C vector immediately after the angioplasty, but before stent implantation, using an infusion-perfusion balloon catheter. The size of the catheter will be selected to match the diameter of the artery as measured from the angiogram, varying, e.g., from 3.0 to 3.5 F in diameter. The balloon is inflated to the optimal pressure and gene transfer is performed during a 10 minute infusion at the rate of 0.5 ml/min with virus titer of 1.15×10^{10} .

In another embodiment, intravascular administration with a gel-coated catheter is contemplated, as has been described in the literature to introduce other transgenes. See, e.g., U.S. Pat. No. 5,674,192 (Catheter coated with tenaciously-adhered swellable hydrogel polymer); Riessen et al., *Human Gene Therapy*, 4: 749-758 (1993); and Steg et al., *Circulation*, 96: 408-411 (1997) and 90: 1648-1656 (1994); all incorporated herein by reference. Briefly, DNA in solution (e.g., the VEGF-C polynucleotide) is applied one or more times ex vivo to the surface of an inflated angioplasty catheter balloon coated with a hydrogel polymer (e.g., Slider with Hydroplus, Mansfield Boston Scientific Corp., Watertown, Mass.). The Hydroplus coating is a hydrophilic polyacrylic acid polymer that is cross-linked to the balloon to form a high molecular weight hydrogel tightly adhered to the balloon. The DNA covered hydrogel is permitted to dry before deflating the

balloon. Re-inflation of the balloon intravascularly, during an angioplasty procedure, causes the transfer of the DNA to the vessel wall.

In yet another embodiment, an expandable elastic membrane or similar structure mounted to or integral with a balloon angioplasty catheter or stent is employed to deliver the VEGF-C transgene. See, e.g., U.S. Pat. Nos. 5,707,385, 5,697,967, 5,700,286, 5,800,507, and 5,776,184, all incorporated by reference herein.

In another variation, the composition containing the VEGF-C transgene is administered extravascularly, e.g., using a device to surround or encapsulate a portion of vessel. See, e.g., International Patent Publication WO 98/20027, incorporated herein by reference, describing a collar that is placed around the outside of an artery (e.g., during a bypass procedure) to deliver a transgene to the arterial wall via a plasmid or liposome vector.

In still another variation, endothelial cells or endothelial progenitor cells are transfected ex vivo with the VEGF-C transgene, and the transfected cells as administered to the mammalian subject. Exemplary procedures for seeding a vascular graft with genetically modified endothelial cells are described in U.S. Pat. No. 5,785,965, incorporated herein by reference.

If the mammalian subject is receiving a vascular graft, the VEGF-C transgene-containing composition may be directly applied to the isolated vessel segment prior to its being grafted in vivo.

In another aspect, the invention provides a method of treating a mammalian subject to prevent stenosis or restenosis of a blood vessel, comprising the step of administering to a mammalian subject in need of treatment to prevent stenosis or restenosis of a blood vessel a composition comprising a VEGF-C polypeptide, in an amount effective to prevent stenosis or restenosis of the blood vessel. In a preferred embodiment, the administering comprises implanting an intravascular stent in the mammalian subject, where the stent is coated or impregnated with the composition. Exemplary materials for constructing a drug-coated or drug-impregnated stent are described in literature cited above and reviewed in Lincoff et al., *Circulation*, 90: 2070-2084 (1994). In another preferred embodiment, the composition comprises microparticles composed of biodegradable polymers such as PGLA, non-degradable polymers, or biological polymers (e.g., starch) which particles encapsulate or are impregnated by the VEGF-C polypeptide. Such particles are delivered to the intravascular wall using, e.g., an infusion angioplasty catheter. Other techniques for achieving locally sustained drug delivery are reviewed in Wilensky et al., *Trends Cardiovasc. Med.*, 3:163-170 (1993), incorporated herein by reference.

Administration via one or more intravenous injections subsequent to the angioplasty or bypass procedure also is contemplated. Localization of the VEGF-C polypeptides to the site of the procedure occurs due to expression of VEGF-C receptors on proliferating endothelial cells. Localization is further facilitated by recombinantly expressing the VEGF-C as a fusion polypeptide (e.g., fused to an apolipoprotein B-100 oligopeptide as described in Shih et al., *Proc. Nat'l. Acad. Sci. USA*, 87:1436-1440 (1990)). Co-administration of VEGF-C polynucleotides and VEGF-C polypeptides also is contemplated.

In yet another embodiment, the invention provides the use of a VEGF-C polynucleotide or VEGF-C polypeptide for the manufacture of a medicament for the treatment or prevention of stenosis or restenosis of a blood vessel.

In still another embodiment, the invention provides a method of treating a mammalian subject to prevent stenosis or

restenosis of a blood vessel, comprising the step of administering to a mammalian subject in need of treatment to prevent stenosis or restenosis of a blood vessel a composition comprising a polynucleotide, the polynucleotide comprising a nucleotide sequence that encodes a vascular endothelial growth factor D (VEGF-D) polypeptide. Such methods are practiced essentially as described herein with respect to VEGF-C-encoding polynucleotides, except that polynucleotides encoding VEGF-D are employed. A detailed description of the human VEGF-D gene and protein are provided in Achen, et al., *Proc. Nat'l Acad. Sci. U.S.A.*, 95(2): 548-553 (1998); International Patent Publication No. WO 98/07832, published Feb. 26, 1998; and in Genbank Accession No. AJ000185, all incorporated herein by reference. A cDNA and deduced amino acid sequence for prepro-VEGF-D is set forth herein in SEQ ID NOS: 3 and 4. Of course, due to the well-known degeneracy of the genetic code, there exist multiple VEGF-D encoding polynucleotide sequences, any of which may be employed according to the methods taught herein.

As described herein in detail with respect to VEGF-C, the use of polynucleotides that encode VEGF-D fragments, VEGF-D analogs, VEGF-D allelic and interspecies variants, and the like which possess in vivo anti-restenosis effects of human VEGF-D are all contemplated as being encompassed by the present invention.

In yet another embodiment, the invention provides a method of treating a mammalian subject to prevent stenosis or restenosis of a blood vessel, comprising the step of administering to a mammalian subject in need of treatment to prevent stenosis or restenosis of a blood vessel a composition comprising a VEGF-D polypeptide, in an amount effective to prevent stenosis or restenosis of the blood vessel. Such methods are practiced essentially as described herein with respect to VEGF-C polypeptides.

In a related aspect, the invention provides materials and devices for practice of the above-described methods.

For example, the polynucleotides, polypeptides, vectors, compositions, and the like that are described for use in methods of the invention are themselves intended as aspects of the invention.

Likewise, the invention also provides surgical devices that are used to treat circulatory disorders, such as intravascular (endovascular) stents, balloon catheters, infusion-perfusion catheters, extravascular collars, elastomeric membranes, and the like, which have been improved by coating with, impregnating with, adhering to, or encapsulating within the device a composition comprising a VEGF-C polynucleotide, a VEGF-C polypeptide, a VEGF-D polynucleotide, and/or a VEGF-D polypeptide.

For example, in one embodiment, the invention provides an endovascular stent characterized by an improvement wherein the stent is coated or impregnated with a composition, the comprising at least one anti-restenosis agent selected from the group consisting of VEGF-C polynucleotides, VEGF-C polypeptides, VEGF-D polynucleotides, and VEGF-D polypeptides. Exemplary stents that may be improved in this manner are described and depicted in U.S. Pat. Nos. 5,800,507 and 5,697,967 (Medtronic, Inc., describing an intraluminal stent comprising fibrin and an elutable drug capable of providing a treatment of restenosis); U.S. Pat. No. 5,776,184 (Medtronic, Inc., describing a stent with a porous coating comprising a polymer and a therapeutic substance in a solid or solid/solution with the polymer); U.S. Pat. No. 5,799,384 (Medtronic, Inc., describing a flexible, cylindrical, metal stent having a biocompatible polymeric surface to contact a body lumen); U.S. Pat. Nos. 5,824,048 and 5,679,400; and U.S. Pat. No. 5,779,729; all of which are specifically incor-

porated herein by reference in the entirety. Implantation of such stents during conventional angioplasty techniques will result in less restenosis than implantation of conventional stents. In this sense, the biocompatibility of the stent is improved.

In another embodiment, the invention provides an extravascular collar for delivery of a therapeutic agent to a blood vessel, characterized by an improvement wherein the collar is coated with or impregnated with or encapsulates a composition, the comprising at least one anti-restenosis agent selected from the group consisting of VEGF-C polynucleotides, VEGF-C polypeptides, VEGF-D polynucleotides, and VEGF-D polypeptides. An exemplary collar to be improved in this manner is described and depicted in International Patent Publication WO 98/20027 (Eurogene, Ltd., collar comprising a body adapted to provide a seal around a vessel and to define a reservoir for holding an anti-restenosis pharmaceutical formulation), incorporated herein by reference.

In yet another embodiment, the invention provides a polymer film for wrapping a stent, characterized by an improvement wherein the film is coated with or impregnated with a composition, the comprising at least one anti-restenosis agent selected from the group consisting of VEGF-C polynucleotides, VEGF-C polypeptides, VEGF-D polynucleotides, and VEGF-D polypeptides. An exemplary film to be improved in this manner is described and depicted in U.S. Pat. Nos. 5,700,286 and 5,707,385 (Advanced Cardiovascular Systems, Inc., sheaths of bioabsorbable polymeric material coated or impregnated with a restenosis-preventing therapeutic agent and attachable to an endovascular stent).

Similarly, the invention includes kits which comprise compounds or compositions of the invention packaged in a manner which facilitates their use to practice methods of the invention. In a simplest embodiment, such a kit includes a compound or composition described herein as useful for practice of the invention (e.g., VEGF-C or VEGF-D polynucleotides or polypeptides), packaged in a container such as a sealed bottle or vessel, with a label affixed to the container or included in the package that describes use of the compound or composition to practice the method of the invention. Preferably, the compound or composition is packaged in a unit dosage form. In another embodiment, a kit of the invention includes both a VEGF-C or VEGF-D polynucleotide or polypeptide composition packaged together with a physical device useful for implementing methods of the invention, such as a stent, a catheter, an extravascular collar, a polymer film, or the like. In another embodiment, a kit of the invention includes both a VEGF-C or VEGF-D polynucleotide or polypeptide composition packaged together with a hydrogel polymer, or microparticle polymers, or other carriers described herein as useful for delivery of the VEGF-C/VEGF-D to the patient.

Additional features and variations of the invention will be apparent to those skilled in the art from the entirety of this application, and all such features are intended as aspects of the invention.

Likewise, features of the invention described herein can be re-combined into additional embodiments that also are intended as aspects of the invention, irrespective of whether the combination of features is specifically mentioned above as an aspect or embodiment of the invention. Also, only such limitations which are described herein as critical to the invention should be viewed as such; variations of the invention lacking limitations which have not been described herein as critical are intended as aspects of the invention.

In addition to the foregoing, the invention includes, as an additional aspect, all embodiments of the invention narrower

in scope in any way than the variations specifically mentioned above. Although the applicant(s) invented the full scope of the claims appended hereto, the claims appended hereto are not intended to encompass within their scope the prior art work of others. Therefore, in the event that statutory prior art within the scope of a claim is brought to the attention of the applicants by a Patent Office or other entity or individual, the applicant(s) reserve the right to exercise amendment rights under applicable patent laws to redefine the subject matter of such a claim to specifically exclude such statutory prior art or obvious variations of statutory prior art from the scope of such a claim. Variations of the invention defined by such amended claims also are intended as aspects of the invention.

BRIEF DESCRIPTION OF THE DRAWING

FIG. 1 depicts a cross-section of a blood vessel into which a drug delivery balloon catheter including a protective sheath has been inserted, the protective sheath serving to cover the balloon during insertion and positioning.

FIG. 2A depicts a perspective view of an expandable membrane having two layers that are spaced apart, prior to joining edges of the layers to each other.

FIG. 2B depicts a perspective view of the membrane of FIG. 2A that has been rolled into a tube and had opposite edges adjoined.

FIGS. 3A and 3B depict, in perspective (3A) and longitudinal cross-section (3B), schematic views of an extravascular collar surrounding a portion of a blood vessel.

FIG. 4A depicts in cross-section a wire coated with a polymer or gel that can include (e.g., be impregnated with) a therapeutic composition.

FIG. 4B depicts a perspective view of an intravascular stent formed from the wire of FIG. 4A.

DETAILED DESCRIPTION OF THE INVENTION

The present invention is based on the discovery that when a gene encoding human Vascular Endothelial Growth Factor C (VEGF-C) is administered to a mammal that has suffered a vascular trauma, such as the trauma that can occur during conventional balloon angioplasty procedures, restenosis of the injured vessel is reduced or eliminated. An in vivo controlled experiment demonstrating the efficacy of a VEGF-C transgene to prevent restenosis is described in detail in Example 1. Example 2 provides a side-by-side comparative study demonstrating that the anti-restenosis effects of VEGF-C appear superior to the anti-restenosis effects of VEGF administered in a comparable manner.

The growth factor named Vascular Endothelial Growth Factor C (VEGF-C), as well as native human, non-human mammalian, and avian polynucleotide sequences encoding VEGF-C, and VEGF-C variants and analogs, have been described in detail in International Patent Application Number PCT/US98/01973, filed Feb. 2, 1998 and published on 6 Aug. 1998 as International Publication Number WO 98/33917; in Joukov et al., *J. Biol. Chem.*, 273(12): 6599-6602 (1998); and in Joukov et al., *EMBO J.*, 16(13): 3898-3911 (1997), all of which are incorporated herein by reference in the entirety. As explained therein in detail, human VEGF-C is initially produced in human cells as a prepro-VEGF-C polypeptide of 419 amino acids. A cDNA and deduced amino acid sequence for human prepro-VEGF-C are set forth in SEQ ID NOs: 1 and 2, respectively, and a cDNA encoding human VEGF-C has been deposited with the American Type Culture Collection (ATCC), 10801 University Blvd., Manassas, Va. 20110-2209 (USA), pursuant to the

provisions of the Budapest Treaty (Deposit date of 24 Jul. 1995 and ATCC Accession Number 97231). VEGF-C sequences from other species also have been reported. See Genbank Accession Nos. MMU73620 (*Mus musculus*); and CCY15837 (*Coturnix coturnix*) for example, incorporated herein by reference.

The prepro-VEGF-C polypeptide is processed in multiple stages to produce a mature and most active VEGF-C polypeptide of about 21-23 kD (as assessed by SDS-PAGE under reducing conditions). Such processing includes cleavage of a signal peptide (SEQ ID NO: 2, residues 1-31); cleavage of a carboxyl-terminal peptide (corresponding approximately to amino acids 228-419 of SEQ ID NO: 2 and having a pattern of spaced cysteine residues reminiscent of a Balbiani ring 3 protein (BR3P) sequence [Dignam et al., *Gene*, 88:133-40 (1990); Paulsson et al., *J. Mol. Biol.*, 211:331-49 (1990)]) to produce a partially-processed form of about 29 kD; and cleavage (apparently extracellularly) of an amino-terminal peptide (corresponding approximately to amino acids 32-103 of SEQ ID NO: 2) to produce a fully-processed mature form of about 21-23 kD. Experimental evidence demonstrates that partially-processed forms of VEGF-C (e.g., the 29 kD form) are able to bind the Flt4 (VEGFR-3) receptor, whereas high affinity binding to VEGFR-2 occurs only with the fully processed forms of VEGF-C. It appears that VEGF-C polypeptides naturally associate as non-disulfide linked dimers.

Moreover, it has been demonstrated that amino acids 103-227 of SEQ ID NO: 2 are not all critical for maintaining VEGF-C functions. A polypeptide consisting of amino acids 113-213 (and lacking residues 103-112 and 214-227) of SEQ ID NO: 2 retains the ability to bind and stimulate VEGF-C receptors, and it is expected that a polypeptide spanning from about residue 131 to about residue 211 will retain VEGF-C biological activity. The cysteine residue at position 156 has been shown to be important for VEGFR-2 binding ability. However, VEGF-C ΔC_{156} polypeptides (i.e., analogs that lack this cysteine due to deletion or substitution) remain potent activators of VEGFR-3. If the anti-restenosis effects of VEGF-C are mediated through VEGFR-3, then use of VEGF-C ΔC_{156} polypeptides (and polynucleotides encoding them) is expected to provide anti-restenosis efficacy while minimizing VEGFR-2-mediated side-effects. The cysteine at position 165 of SEQ ID NO: 2 is essential for binding either receptor, whereas analogs lacking the cysteines at positions 83 or 137 compete with native VEGF-C for binding with both receptors and stimulate both receptors.

An alignment of human VEGF-C with VEGF-C from other species (performed using any generally accepted alignment algorithm) suggests additional residues wherein modifications can be introduced (e.g., insertions, substitutions, and/or deletions) without destroying VEGF-C biological activity. Any position at which aligned VEGF-C polypeptides of two or more species have different amino acids, especially different amino acids with side chains of different chemical character, is a likely position susceptible to modification without concomitant elimination of function. An exemplary alignment of human, murine, and quail VEGF-C is set forth in FIG. 5 of PCT/US98/01973.

Apart from the foregoing considerations, it will be understood that innumerable conservative amino acid substitutions can be performed to a wildtype VEGF-C sequence which are likely to result in a polypeptide that retains VEGF-C biological activities, especially if the number of such substitutions is small. By "conservative amino acid substitution" is meant substitution of an amino acid with an amino acid having a side chain of a similar chemical character. Similar amino acids for making conservative substitutions include those having an

acidic side chain (glutamic acid, aspartic acid); a basic side chain (arginine, lysine, histidine); a polar amide side chain (glutamine, asparagine); a hydrophobic, aliphatic side chain (leucine, isoleucine, valine, alanine, glycine); an aromatic side chain (phenylalanine, tryptophan, tyrosine); a small side chain (glycine, alanine, serine, threonine, methionine); or an aliphatic hydroxyl side chain (serine, threonine). Addition or deletion of one or a few internal amino acids without destroying VEGF-C biological activities also is contemplated.

Without intending to be limited to a particular theory, the mechanism behind the efficacy of VEGF-C in preventing restenosis is believed to relate to the ability of VEGF-C to stimulate re-endothelialization of the injured vessel (and/or of the intravascular stent) without significant concomitant stimulation of smooth muscle proliferation in the vessel. VEGF-C also may inhibit smooth muscle cell proliferation. Accordingly, candidate VEGF-C analog polypeptides can be rapidly screened first for their ability to bind and stimulate autophosphorylation of known VEGF-C receptors (VEGFR-2 and VEGFR-3). Polypeptides that stimulate one or both known receptors are rapidly re-screened in vitro for their mitogenic and/or chemotactic activity against cultured capillary or arterial endothelial cells (e.g., as described in WO 98/33917). Polypeptides with mitogenic and/or chemotactic activity are then screened in vivo as described herein for the ability to prevent restenosis. In this way, variants (analogs) of naturally occurring VEGF-C proteins are rapidly screened to determine whether or not the variants have the requisite biological activity to constitute "VEGF-C polypeptides" for use in the present invention.

The growth factor named Vascular Endothelial Growth Factor D (VEGF-D), as well as human sequences encoding VEGF-D, and VEGF-D variants and analogs, have been described in detail in International Patent Application Number PCT/US97/14696, filed 21 Aug. 1997 and published on 26 Feb. 1998 as International Publication Number WO 98/07832; and in Achen, et al., *Proc. Nat'l Acad. Sci. U.S.A.*, 95(2): 548-553 (1998), both incorporated herein by reference in the entirety. As explained therein in detail, human VEGF-D is initially produced in human cells as a prepro-VEGF-D polypeptide of 354 amino acids. A cDNA and deduced amino acid sequence for human prepro-VEGF-D are set forth in SEQ ID NOS: 3 and 4, respectively. VEGF-D sequences from other species also have been reported. See Genbank Accession Nos. D89628 (*Mus musculus*); and AF014827 (*Rattus norvegicus*), for example, incorporated herein by reference.

The prepro-VEGF-D polypeptide has a putative signal peptide of 21 amino acids and is apparently proteolytically processed in a manner analogous to the processing of prepro-VEGF-C. A "recombinantly matured" VEGF-D lacking residues 1-92 and 202-354 of SEQ ID NO: 4 retains the ability to activate receptors VEGFR-2 and VEGFR-3, and appears to associate as non-covalently linked dimers. Thus, preferred VEGF-D polynucleotides include those polynucleotides that comprise a nucleotide sequence encoding amino acids 93-201 of SEQ ID NO: 4. The guidance provided above for introducing function-preserving modifications into VEGF-C polypeptides is also suitable for introducing function-preserving modifications into VEGF-D polypeptides.

A therapeutic or prophylactic treatment of restenosis provided by the present invention involves administering to a mammalian subjection such as a human a composition comprising a VEGF-C or VEGF-D polynucleotide or polypeptide or combination thereof (sometimes generically referred to herein as a "VEGF-C or VEGF-D therapeutic agent").

The "administering" may be performed using any medically-accepted means for introducing a therapeutic directly or

indirectly into the vasculature of a mammalian subject, including but not limited to injections; oral ingestion; intranasal or topical administration; and the like. In a preferred embodiment, administration of the composition comprising the VEGF-C or VEGF-D polynucleotide or polypeptide composition is performed intravascularly, such as by intravenous, intra-arterial, or intracoronary arterial injection.

In a highly preferred embodiment, the composition is administered locally, e.g., to the site of angioplasty or bypass. For example, the administering comprises a catheter-mediated transfer of the therapeutic composition into a blood vessel of the mammalian subject, especially into a coronary artery of the mammalian subject. Exemplary materials and methods for local delivery are reviewed in Lincoff et al., *Circulation*, 90: 2070-2084 (1994); and Wilensky et al., *Trends Cardiovasc. Med.*, 3:163-170 (1993), both incorporated herein by reference. For example, the composition is administered using infusion-perfusion balloon catheters (preferably microporous balloon catheters) such as those that have been described in the literature for intracoronary drug infusions. See, e.g., U.S. Pat. No. 5,713,860 (Intravascular Catheter with Infusion Array); U.S. Pat. No. 5,087,244; U.S. Pat. No. 5,653,689; and Wolinsky et al., *J. Am. Coll. Cardiol.*, 15: 475-481 (1990) (Wolinsky Infusion Catheter); and Lambert et al., *Coron. Artery Dis.*, 4: 469-475 (1993), all of which are incorporated herein by reference in their entirety. Use of such catheters for site-directed somatic cell gene therapy is described, e.g., in Mazur et al., *Texas Heart Institute Journal*, 21: 104-111 (1994), incorporated herein by reference.

For example, in patients with angina pectoris due to a single or multiple lesions in coronary arteries and for whom PTCA is prescribed on the basis of primary coronary angiogram findings, an exemplary protocol involves performing PTCA through a 7 F guiding catheter according to standard clinical practice using the femoral approach. If an optimal result is not achieved with PTCA alone, then an endovascular stent also is implanted. (A nonoptimal result is defined as residual stenosis of >30% of the luminal diameter according to a visual estimate, and B or C type dissection.) Arterial gene transfer at the site of balloon dilatation is performed immediately after the angioplasty, but before stent implantation, using an infusion-perfusion balloon catheter. The size of the catheter will be selected to match the diameter of the artery as measured from the angiogram, varying, e.g., from 3.0 to 3.5 F in diameter. The balloon is inflated to the optimal pressure and gene transfer is performed during a 10 minute infusion at the rate of 0.5 ml/min with virus titer of 1.15×10^{10} .

In another embodiment, intravascular administration with a gel-coated catheter is contemplated, as has been described in the literature to introduce other transgenes. See, e.g., U.S. Pat. No. 5,674,192 (Catheter coated with tenaciously-adhered swellable hydrogel polymer); Riessen et al., *Human Gene Therapy*, 4: 749-758 (1993); and Steg et al., *Circulation*, 96: 408-411 (1997) and 90: 1648-1656 (1994); all incorporated herein by reference. As shown in FIG. 1, a catheter 10 is provided to which an inflatable balloon 12 is attached at a distal end. The balloon includes a swellable hydrogel polymer coating 14 capable of absorbing a solution comprising a therapeutic VEGF-C or VEGF-D therapeutic agent. Briefly, DNA in solution (e.g., the VEGF-C or VEGF-D polynucleotide) is applied one or more times ex vivo to the surface of an inflated angioplasty catheter balloon coated with a hydrogel polymer (e.g., Slider with Hydroplus, Mansfield Boston Scientific Corp., Watertown, Mass.). The Hydroplus coating is a hydrophilic polyacrylic acid polymer that is cross-linked to the balloon to form a high molecular weight hydrogel tightly

adhered to the balloon. The DNA covered hydrogel is permitted to dry before deflating the balloon. Re-inflation of the balloon intravascularly, during an angioplasty procedure, causes the transfer of the DNA to the vessel wall. Thus, referring again to FIG. 1, the catheter with attached, coated balloon is inserted into the lumen 16 of a blood vessel 18 while covered by a protective sheath 20 to minimize exposure of the coated balloon to the blood prior to placement at the site of an occlusion 22. When the instrument has been positioned at the treatment region, the protective sheath is drawn back or the catheter is moved forward to expose the balloon, which is inflated to compress the balloon (and thus the coating) into the vessel wall, causing transfer of the VEGF-C or VEGF-D therapeutic agent to the tissue, in a manner analogous to squeezing liquid from a compressed sponge or transferring wet paint to a surface by contact.

In yet another embodiment, an expandable elastic membrane, film, or similar structure, mounted to or integral with a balloon angioplasty catheter or stent, is employed to deliver the VEGF-C or VEGF-D therapeutic agent. See, e.g., U.S. Pat. Nos. 5,707,385, 5,697,967, 5,700,286, 5,800,507, and 5,776,184, all incorporated by reference herein. As shown in FIGS. 2A-2B, a single layer 30 or multi-layer 30, 32 sheet of elastic membrane material (FIG. 2A) is formed into a tubular structure 34 (FIG. 2B), e.g., by bringing together and adhering opposite edges of the sheet(s), e.g., in an overlapping or an abutting relationship. In this manner the elastomeric material may be wrapped around a catheter balloon or stent. A therapeutic VEGF-C or VEGF-D composition is combined with the membrane using any suitable means, including injection molding, coating, diffusion, and absorption techniques. In the multilayer embodiment depicted in the Figures, the edges of the two layers may be joined to form a fluid-tight seal. In a preferred embodiment, one layer of material is first processed by stretching the material and introducing a plurality of microscopic holes or slits 36. After the layers have been joined together, the sheet can be stretched and injected with the therapeutic VEGF-C/D composition through one of the holes or slits to fill the cavity that exists between the layers. The sheet is then relaxed, causing the holes to close and sealing the therapeutic composition between the layers until such time as the sheet is again stretched. This occurs, for example, at the time that an endovascular stent or balloon covered by the sheet is expanded within the lumen of a stenosed blood vessel. The expanding stent or balloon presses radially outward against the inner surface 38 of the tubular sheet covering, thus stretching the sheet, opening the holes, and delivering the therapeutic agent to the walls of the vessel.

In another variation, the composition containing the VEGF-C or VEGF-D therapeutic is administered extravascularly, e.g., using a device to surround or encapsulate a portion of vessel. See, e.g., International Patent Publication WO 98/20027, incorporated herein by reference, describing a collar that is placed around the outside of an artery (e.g., during a bypass procedure) to deliver a transgene to the arterial wall via a plasmid or liposome vector. As shown in FIGS. 3A and 3B, an extravascular collar 40 including a void space 42 defined by a wall 44 formed, e.g., of a biodegradable or biocompatible material. The collar touches the outer wall 46 of a blood vessel 48 at the collar's outer extremities 50. Blood 52 flows through the lumen of the blood vessel. A longitudinal slit 54 in the flexible collar permits the collar to be deformed and placed around the vessel and then sealed using a conventional tissue glue, such as a thrombin glue.

In still another variation, endothelial cells or endothelial progenitor cells are transfected *ex vivo* with the VEGF-C or VEGF-D transgene, and the transfected cells as administered

to the mammalian subject. Exemplary procedures for seeding a vascular graft with genetically modified endothelial cells are described in U.S. Pat. No. 5,785,965, incorporated herein by reference.

If the mammalian subject is receiving a vascular graft, the VEGF-C or VEGF-D therapeutic composition may be directly applied to the isolated vessel segment prior to its being grafted *in vivo*.

In another preferred embodiment, the administering comprises implanting an intravascular stent in the mammalian subject, where the stent is coated or impregnated with the therapeutic VEGF-C/D gene/protein composition. Exemplary materials for constructing a drug-coated or drug-impregnated stent are described in literature cited above and reviewed in Lincoff et al., *Circulation*, 90: 2070-2084 (1994). As shown in FIGS. 4A and 4B, a metal or polymeric wire 70 for forming a stent is coated with a composition 72 such as a porous biocompatible polymer or gel that is impregnated with (or can be dipped in or otherwise easily coated immediately prior to use with) a VEGF-C or VEGF-D therapeutic composition. The wire is coiled, woven, or otherwise formed into a stent 74 suitable for implantation into the lumen of a vessel using conventional materials and techniques, such as intravascular angioplasty catheterization. Exemplary stents that may be improved in this manner are described and depicted in U.S. Pat. Nos. 5,800,507 and 5,697,967 (Medtronic, Inc., describing an intraluminal stent comprising fibrin and an elutable drug capable of providing a treatment of restenosis); U.S. Pat. No. 5,776,184 (Medtronic, Inc., describing a stent with a porous coating comprising a polymer and a therapeutic substance in a solid or solid/solution with the polymer); U.S. Pat. No. 5,799,384 (Medtronic, Inc., describing a flexible, cylindrical, metal stent having a biocompatible polymeric surface to contact a body lumen); U.S. Pat. Nos. 5,824,048 and 5,679,400; and U.S. Pat. No. 5,779,729; all of which are specifically incorporated herein by reference in the entirety. Implantation of such stents during conventional angioplasty techniques will result in less restenosis than implantation of conventional stents. In this sense, the biocompatibility of the stent is improved.

In another preferred embodiment, the composition comprises microparticles composed of biodegradable polymers such as PGLA, non-degradable polymers, or biological polymers (e.g., starch) which particles encapsulate or are impregnated by the VEGF-C or VEGF-C polypeptide/polynucleotide. Such particles are delivered to the intravascular wall using, e.g., an infusion angioplasty catheter. Other techniques for achieving locally sustained drug delivery are reviewed in Wilensky et al., *Trends Cardiovasc. Med.*, 3:163-170 (1993), incorporated herein by reference.

Administration via one or more intravenous injections subsequent to the angioplasty or bypass procedure also is contemplated. Localization of the VEGF-C or VEGF-D polypeptides to the site of the procedure occurs due to expression of VEGF-C/D receptors on proliferating endothelial cells. Localization is further facilitated by recombinantly expressing the VEGF-C or VEGF-D as a fusion polypeptide (e.g., fused to an apolipoprotein B-100 oligopeptide as described in Shih et al., *Proc. Nat'l. Acad. Sci. USA*, 87:1436-1440 (1990)).

The pharmaceutical efficacy of VEGF-C polynucleotides, VEGF-C polypeptides, VEGF-D polynucleotides, and VEGF-D polypeptides to prevent stenosis or restenosis of a blood vessel is demonstrated *in vivo*, e.g., using procedures such as those described in the following examples, some of which are prophetic. The examples assist in further describing the invention, but are not intended in any way to limit the scope of the invention.

Use of Adenovirus-Mediated VEGF-C Gene Transfer to Prevent Restenosis

The following experiments, performed *in vivo* in a rabbit restenosis model, demonstrate the efficacy of adenovirus-mediated intravascular VEGF-C gene transfer for the prevention of post-angioplasty restenosis.

A. Materials and Methods

1. Adenoviral Constructs.

An adenovirus plasmid containing a cDNA encoding the complete human prepro-VEGF-C open reading frame operably linked to a cytomegalovirus (CMV) promoter and human growth hormone polyadenylation signal sequence was constructed as follows. A DNA fragment comprising a CMV promoter sequence was prepared by digesting the pcDNA3.1+ vector (Invitrogen) with Sal I and filling-in the 5' overhangs with the Klenow enzyme. The CMV promoter (nucleotides 5431-911) was excised from the vector with Hind III and isolated. A full-length human VEGF-C cDNA containing the 1997 bp sequence specified in SEQ ID NO: 1 (as well as less than 50 bases of additional non-coding and polylinker sequence) was excised from a VEGF-C pREP7 expression vector [described in WO 98/33917] with Hind III and Xho I and isolated. A human growth hormone polyadenylation signal (~860 bp) was excised from an α MHC vector with Sal I and BamHI. The CMV promoter, VEGF-C cDNA, and hGH polyadenylation signal fragments were simultaneously ligated into a BamHI and EcoRV-digested pCRII vector. The ligated CMV promoter and VEGF-C cDNA is shown in SEQ ID NO: 17. The resulting construct was opened with BglIII and partially-digested with BamHI. The full transcriptional unit was ligated into BglIII-opened pAdBgIII vector. This construct [designated pAdBgIII VEGF-C] was then used to create recombinant adenovirus containing the CMV-VEGF-C-hGH transcriptional unit, using standard homologous recombination techniques. [Barr et al., *Gene Ther.*, 1: 51-58 (1994).] Replication-deficient E1-E3 deleted adenoviruses were produced in 293 cells and concentrated by ultracentrifugation using techniques known in the literature. [See, e.g., Barr et al. (1994).] A control plasmid comprising the lacZ gene operably linked to the same promoter was also used. [Laitinen M. et al., *Hum. Gene Ther.*, 9: 1481-1486 (1998).] The lacZ adenovirus had a nuclear targeted signal, to direct the β -galactosidase expression to the nucleus. Replication-deficient E1-E3 deleted adenoviruses were produced in 293 cells and concentrated by ultracentrifugation (Barr et al., 1994). The adenoviral preparations were analyzed for the absence of helper viruses and bacteriological contaminants.

2. Animal Model.

New Zealand White rabbits were employed for the gene transfer study. A first group of rabbits was fed a 0.25% cholesterol diet for two weeks, then subjected to balloon denudation of the aorta, then subjected three days later to the adenovirus-mediated gene transfer. A second group of rabbits was only subjected to the gene transfer. Animals were sacrificed 2 or 4 weeks after the gene transfer. The number of experimental (VEGF-C) and control (lacZ) animals in both study groups was 6.

In the first group of rabbits, the whole aorta, beginning from the tip of the arch, was denuded using a 4.0 F arterial embolectomy catheter (Sorin Biomedical, Irvine, Calif.). The catheter was introduced via the right iliac artery up to the aortic arch and inflated, and the aorta was denuded twice.

3. Gene Transfer.

The gene transfer was performed using a 3.0 F channel balloon local drug delivery catheter (Boston Scientific Corp., Maple Grove, Mass.). Using fluoroscopic control, the balloon catheter was positioned caudal to the left renal artery, in a segment free of side branches, via a 5 F percutaneous introducer sheath (Arrow International, Reading, Pa.) in the right carotid artery and inflated to 6 ATM with a mixture of contrast media and saline. The anatomical location of the balloon catheter was determined by measuring its distance from the aortic orifice of the left renal artery. Virus titer of 1.15×10^{10} plaque forming units (pfu) was administered to each animal in a final volume of 2 ml (0.9% NaCl), and the gene transfer was performed at 6 ATM pressure for 10 minutes (0.2 ml/min). In the second study group the animals had only gene transfer and they were sacrificed 2 weeks after the gene transfer. The number of animals in each study group (0.9% NaCl only; lacZ gene transfer; and VEGF-C gene transfer) was 3. All studies were approved by Experimental Animal Committee of the University of Kuopio in Finland.

4. Histology.

Three hours before sacrifice, the animals were injected intravenously with 50 mg of BrdU dissolved in 40% ethanol. After the sacrifice, the aortic segment where the gene transfer had been performed was removed, flushed gently with saline, and divided into five equal segments. The proximal segment was snap frozen in liquid nitrogen and stored at -70° C. The next segment was immersion-fixed in 4% paraformaldehyde/15% sucrose (pH 7.4) for 4 hours, rinsed in 15% sucrose (pH 7.4) overnight, and embedded in paraffin. The medial segment was immersion-fixed in 4% paraformaldehyde/phosphate buffered saline (PBS) (pH 7.4) for 10 minutes, rinsed 2 hours in PBS, embedded in OCT compound (Miles), and stored at -70° C. The fourth segment was immersion-fixed in 70% ethanol overnight and embedded in paraffin. The distal segment was directly stained for β -galactosidase activity in X-GAL staining solution at $+37^\circ$ C. for 16 hours, immersion-fixed in 4% paraformaldehyde/15% sucrose (pH 7.4) for 4 hours, rinsed in 15% sucrose overnight, and embedded in paraffin. Paraffin sections were used for immunocytochemical detection of smooth muscle cells (SMC), macrophages, and endothelium. Gene transfer efficiency was evaluated using X-GAL staining of OCT-embedded tissues. BrdU-positive cells were detected according to manufacturer's instructions. Morphometry was performed using haematoxylin-eosin stained paraffin sections using image analysis software. Measurements were taken independently by two observers from multiple sections, without knowledge of the origin of the sections. Intima/media (I/M) ratio was used as a parameter for intimal thickening.

B. Results.

Histological analysis of the balloon-denuded mice revealed that the lacZ-transfected control group had an I/M ratio of 0.61 two weeks after the gene transfer, which represented a statistically significant difference ($p < 0.05$) from the VEGF-C-transfected groups (I/M ratio of 0.40). The tendency that VEGF-C group had a smaller I/M ratio persisted at 4 weeks time point after the gene transfer.

In the second group of rabbits that were subjected only to gene transfer to the vessel wall (without endothelial denudation), the I/M ratio in the lacZ group was 0.3, compared to 0.15 for the VEGF-C group. This difference, too, represented a statistically significant ($p < 0.05$) inhibition in neointima formation in VEGF-C group.

The BrdU labeling will permit analysis of smooth muscle cell proliferation in VEGF-C-transfected versus control (lacZ) animals. SMC proliferation is expected to be reduced in the VEGF-C-transfected population.

The foregoing data demonstrate that VEGF-C gene transfer significantly reduced intimal thickening at two weeks time point after aortic denudation and after vessel wall damage caused by the gene transfer catheter without balloon denudation. These data indicate a therapeutic utility for VEGF-C gene transfer for the prevention of post-angioplasty restenosis.

EXAMPLE 2

Comparative Example Demonstrating that Anti-Restenosis Effects of VEGF-C Appear Superior to Those of VEGF

The following experiments demonstrate the efficacy of adenovirus-mediated intravascular VEGF and VEGF-C gene transfer for the prevention of post-angioplasty restenosis, and demonstrates that VEGF-C appeared to provide a superior therapeutic efficacy compared to VEGF.

A. Materials and Methods

1. Adenoviral Constructs.

VEGF (murine VEGF-A₁₆₄; SEQ ID NO: 18) adenovirus was constructed using the same promoter as the VEGF-C construct, and following similar procedure as described in Example 1. The VEGF-A₁₆₄ adenoviral construct was produced in 293T cells and concentrated essentially as described in Example 1, and analyzed to be free of helper virus, lipopolysaccharides, and bacterial contaminants.

2. Animal Model.

Sixty three New Zealand White rabbits were divided into two major groups, the first having 0.25% cholesterol diet for two weeks and balloon denudation of the aorta before gene transfer, and the second group having only the gene transfer. Gene transfer was performed in the first group of rabbits three days after denudation, and the animals were sacrificed 2 or 4 weeks after the gene transfer. Number of rabbits in each study group (lacZ, VEGF, and VEGF-C) at both time points was 6. In the second study group, the rabbits had only the gene transfer, without cholesterol diet or balloon denudation, and were sacrificed 2 or 4 weeks after the gene transfer. The number of rabbits in each study group (0.9% saline, lacZ, VEGF, and VEGF-C) was 3.

3. Gene Transfer.

Gene transfer was performed according to the procedure described in Example 1.

4. Histology

Histology was performed essentially as described in Example 1 with the following modifications: SMC were detected using HHF35 (DAKO, 1:50 dilution), macrophages were detected using RAM-11 (DAKO, 1:50 dilution), endothelium was detected using CD31 (DAKO, 1:50 dilution), and T cells were detected using MCA 805 (DAKO, 1:100 dilution). Controls for immunostainings included incubations with class- and species matched immunoglobulins and incubations where primary antibodies were omitted. Morphometry and image analysis were performed using Image-Pro Plus™ software and an Olympus AX70 microscope (Olympus Optical, Japan). Statistical analyses were performed using the ANOVA and modified t-test. $P < 0.05$ was considered statistically significant.

B. Results

Histological analysis of the balloon-denuded rabbit aorta shows intimal thickening and SMC proliferation. Two weeks after gene transfer, the lacZ control group had the highest I/M ratio (0.57 ± 0.04) whereas VEGF-C (0.38 ± 0.02) and VEGF (0.49 ± 0.17) groups showed decreased intimal thickening. The difference in I/M ratios between lacZ and VEGF-C

groups was significant ($P < 0.05$), whereas those between lacZ and VEGF groups were not statistically significant, at the two-week time point. The tendency that both VEGF and VEGF-C groups had smaller I/M ratios persisted at the four week time point when the I/M ratio was 0.73 ± 0.16 , 0.44 ± 0.14 , and 0.63 ± 0.21 for the lacZ, VEGF-C, and VEGF groups, respectively. Hematoxylin-eosin and immunostainings of the transfected arteries indicate that intimal thickening in all arteries was composed predominantly of SMC.

Use of adenoviral vectors can lead to immunological and inflammatory responses, partly because high titer adenovirus induces expression of NF- κ B and activates a CTL response. However, no signs of inflammation nor foam cell accumulation were detected as judged by macrophage and T-cell immunostainings. In addition, human clinical gene therapy grade viruses were used together with short exposure times in the transfected arteries, which may also help explain the absence of severe inflammatory reactions in this study.

The percentage of proliferating cells was analyzed using BrdU labeling. No significant differences were seen, although the VEGF-C group tended to have a lower proliferation rate, consistent with the observation that VEGF-C transduced arteries had smaller I/M ratios at both time points. Two weeks after balloon denudation, the percentage of proliferating cells was 1.8 ± 0.4 , 2.2 ± 0.7 , and 1.2 ± 0.0 for the lacZ, VEGF, and VEGF-C groups, respectively, and after four weeks, the percentage of proliferating cells was 0.3 ± 0.1 , 1.2 ± 0.5 , and 0.3 ± 0.1 for the lacZ, VEGF, and VEGF-C groups, respectively. Endothelial regrowth was analyzed by measuring the length of intact endothelium from histological sections. No significant differences were found between the study groups.

The potential of adenovirus to cause damage to the vessel wall and neointima formation was tested by performing high-titer adenovirus gene transfer to intact abdominal aorta of rabbits without balloon-denudation. Control rabbits were treated in the same way with 0.9% saline. The positioning of the gene transfer catheter caused some internal elastic lamina damage and moderate induction of neointima formation after the procedure. At the two-week time point, the I/M ratio in the lacZ group was 0.24 ± 0.06 , in the control group 0.28 ± 0.05 , in the VEGF-C group 0.18 ± 0.07 , and in the VEGF group 0.15 ± 0.03 . At the four-week time point the lacZ group had an I/M ratio of 0.22 ± 0.13 , the VEGF-C group 0.13 ± 0.03 , and the VEGF group 0.23 ± 0.11 .

This study shows a beneficial therapeutic effect of intravascular adenovirus-mediated VEGF-C gene transfer on the vessel wall after balloon injury, and also compares VEGF-C and VEGF adenovirus-mediated gene transfer for the prevention of neointima formation. Although different receptor binding profiles of VEGF-C and VEGF might have led to different biological effects in the vessel wall, both VEGFs reduced intimal thickening two weeks after gene transfer. Thus, both VEGFs are potential candidates for vascular gene therapy of ischemic atherosclerotic diseases. However, according to this experiment, VEGF-C appears to prevent restenosis more effectively than VEGF in this model system. The superior ability of VEGF-C to prevent restenosis, as compared to VEGF, could be due to expression or activity of VEGFR-3 which is a receptor for VEGF-C and VEGF-D, but not for VEGF. Alternatively, the apparent superiority may be attributable to a restenosis-promoting effect of VEGF mediated through VEGFR-1 or due to differential ligand effects (VEGF-C versus VEGF) mediated thru the common receptor VEGFR-2, which is reportedly expressed in vascular smooth muscle cells. [See Grosskreutz et al., *Microvasc. Res.*, 58(2): 128-136 (September, 1999).

21

EXAMPLE 3

Expression of Transfected VEGFs in the Aortic Wall

Using the aortic segments from the same experimental animals described in Example 2, mRNA expression of lacZ, VEGF-C and VEGF (murine VEGF-A₁₆₄) was analyzed in aortic tissue after gene transfer. Total RNA was extracted from transfected aortic segments using Trizol Reagent (Gibco-BRL), and 2 µg of RNA was used for cDNA synthesis. Primers for lacZ, VEGF-C and VEGF were designed to distinguish between endogenous and transduced genes by selecting the 5' primers from the CMV promoter and the 3' primers from the coding regions.

For lacZ amplification, primers were: 5' primer 5'-TTG-GAGGCCTAGGCTTTTGC-3' (SEQ ID NO: 5) and 3' primer 5'-ATACTGTCGTCGTCCTCA-3' (SEQ ID NO: 6). The first PCR cycle was an initial incubation at 96° C. for 4 minutes followed by 80° C. for 3 minutes during which the DNA polymerase was added. This was followed by 30 cycles, each consisting of 94° C. for 45 seconds, 58° C. for 45 seconds, and 72° C. for 50 seconds, followed by a final extension of 72° C. for 5 minutes. 5 µl of the first PCR product was used for the second PCR with 5' primer 5'-GGTAGAA-GACCCCAAGGACTTT-3'(SEQ ID NO: 7) and 3' primer 5'-CGCCATTCGCCATTTCAG-3' (SEQ ID NO: 8). The first PCR cycle was an initial incubation at 96° C. for 3 minutes followed by 80° C. for 3 minutes followed by 32 cycles, each consisting of 94° C. for 60 seconds, 58° C. for 15 seconds, and 72° C. for 90 seconds, followed by a final extension of 72° C. for 5 minutes.

For VEGF-C amplification, primers were: 5' primer 5'-CT-GCTTACTGGCTTATCG-3' (SEQ ID NO: 9) and 3' primer 5'-CCTGTTCTCTGTTATGTTGC-3' (SEQ ID NO: 10). The first PCR-cycle was an initial incubation at 96° C. for 4 minutes followed by 80° C. for 3 minutes during which the DNA polymerase was added. This was followed by 39 cycles each consisting of 94° C. for 30 seconds, 56° C. for 40 seconds, and 72° C. for 90 seconds, followed by a final extension of 72° C. for 5 minutes. 5 µl of the first PCR product was used for the second PCR with 5' primer 5'-TCTC-CAAAAAGCTACACCG-3' (SEQ ID NO: 11) and 3' primer 5'-CAAGTGCATGGTGGGAAGG-3' (SEQ ID NO: 12). The first PCR cycle was an initial incubation at 96° C. for 3 minutes followed by 80° C. for 3 minutes followed by 39 cycles each consisting of 94° C. for 60 seconds, 57° C. for 30 seconds, and 72° C. for 90 seconds, followed by a final extension of 72° C. for 5 minutes.

For VEGF amplification, primers were: 5' primer 5'-TC-GATCCATGAACCTTCTGC-3' (SEQ ID NO: 13) and 3' primer 5'-TTCGTTAACTCAAGCTGCC-3' (SEQ ID NO: 14). The first PCR cycle was an initial incubation at 96° C. for 4 minutes followed by 80° C. for 3 minutes, followed by 39 cycles each consisting of 94° C. for 30 seconds, 53° C. for 40 seconds, and 72° C. for 90 seconds, followed by a final extension of 72° C. for 5 minutes. 5 µl of the first PCR product was used for the second PCR with 5' primer 5'-GACCCTG-GCTTTACTGCTG-3' (SEQ ID NO: 15) and 3' primer 5'-GGAACATTACAGTCTGCG-3' (SEQ ID NO: 16). The first PCR cycle was an initial incubation at 96° C. for 3 minutes followed by 80° C. for 3 minutes followed by 39 cycles each consisting of 94° C. for 60 seconds, 54° C. for 30 seconds, and 72° C. for 90 seconds, followed by a final extension of 72° C. for 5 minutes.

The mRNA of lacZ, VEGF-C and VEGF was detected in aortic wall tissue up to four weeks after gene transfer.

22

EXAMPLE 4

Expression of VEGF Receptors in the Aortic Wall

Using the experimental animals described in Example 2, VEGFR-1, VEGFR-2, and VEGFR-3 expression in aortic tissue was analyzed by immunostainings and in situ hybridization. Immunohistochemistry was performed using clone sc-316 (Santa Cruz Biotechnology, 1:50 dilution) to detect VEGFR-1, clone sc-6251 (Santa Cruz Biotechnology, 1:500 dilution) to detect VEGFR-2, and clone sc-637 (Santa Cruz Biotechnology, 1:300 dilution) to detect VEGFR-3. Controls for immunostainings included incubations with class- and species matched immunoglobulins and incubations where primary antibodies were omitted. In situ hybridization of VEGF receptor mRNAs was carried out using ³³P-UTP labeled riboprobes. Expression of all receptors was localized to endothelium. VEGFR-2 was also expressed in neointimal SMCs.

EXAMPLE 5

Use of Naked VEGF-C Transgene Therapy to Prevent Restenosis

The procedures described in Example 1 or 2 are repeated, with the following modifications. Instead of using an adenovirus vector for delivery of the VEGF-C transgene, a mammalian expression vector is constructed for direct gene transfer (of naked plasmid DNA). The VEGF-C coding sequence is operably linked to a suitable promoter, such as the CMV promoter, and preferably linked to a suitable polyadenylation sequence, such as the human growth hormone polyadenylation sequence. Exemplary VEGF-C vectors can be modeled from vectors that have been described in the literature to perform vector-free gene transfer for other growth factors, by substituting a VEGF-C coding sequence for a VEGF coding sequence. [See, e.g., Isner et al., *Circulation*, 91: 2687-2692 (1995); and Isner et al., *Human Gene Therapy*, 7: 989-1011 (1996), incorporated herein by reference.] vector. A similar construct comprising a lacZ gene is used as a control.

A Hydrogel-coated balloon catheter (Boston Scientific) is used to deliver the VEGF-C transgene essentially as described in Asahara et al., *Circulation*, 94: 3291-3302 (Dec. 15, 1996), incorporated herein by reference. Briefly, an angioplasty balloon is prepared ex vivo by advancing the deflated balloon completely through a teflon protective sheath (Boston Scientific). The balloon is inflated and a conventional pipette is used to apply the transgene construct (e.g., 50-5000 µg transgene DNA in a saline solution) to the Hydrogel polymer coating the external surface of the inflated balloon. After the transgene solution has dried, the balloon is deflated, withdrawn into the protective sheath, and re-inflated to minimize blood flow across the balloon surface until the balloon is properly positioned in the target artery.

Intima/media (I/M) ratio is again used as a parameter for intimal thickening. Reduced I/M ratio in animals treated with the VEGF-C transgene-coated balloon catheter is considered indicative of therapeutic efficacy. As described in Example 2,

23

comparison of the therapeutic efficacy of VEGF-C gene transfer with other therapies, such as VEGF gene transfer, can be conducted in parallel.

EXAMPLE 6

Use of VEGF-C Gene Therapy to Prevent Restenosis Following Angioplasty with Stent

The procedures described in the preceding examples are repeated with the modification that initial balloon angioplasty is accompanied by implantation of a coronary stent using conventional procedures. The VEGF-C transgene is delivered concurrently or immediately before or after stent implantation essentially as described in the preceding examples. Increased quantities (e.g., two-fold to ten-fold) of the transgene (compared to angioplasty without stent) and increased transfection time may be desirable, as described in Van Belle et al., *J. Am. Coll. Cardiol.*, 29:1371-1379 (May, 1997), incorporated by reference herein. Decreased neointimal thickening and/or decreased thrombotic occlusion in the VEGF-C gene-treated animals versus control animals treated with a marker gene is considered evidence of the efficacy of the VEGF-C gene therapy.

EXAMPLE 7

Use of an Extravascular Collar to Reduce Vascular Stenosis

An inert silicone collar such as described in International Patent Publication No. WO 98/20027 is surgically implanted around the carotid arteries of New Zealand White Rabbits. The collar acts as an irritation agent that will induce intimal thickening, and contains a reservoir suitable for local delivery of a VEGF-C transgene or protein pharmaceutical formulation. Gene transfer, using the VEGF-C adenovirus construct or control construct described in Example 1 is initiated five days later by injecting 10^8 - 10^{11} pfu into the collar. Animals are sacrificed 14 or 28 days later and histological examinations are performed as described in Example 1. Intima/media thickness ratio [Yla-Herttuala et al., *Arteriosclerosis*, 6: 230-236 (1986)] is used as an indicia of stenosis. Reduced I/M ratio in the VEGF-C-transfected rabbits, as compared to the lacZ control rabbits, indicates therapeutic efficacy of VEGF-C gene transfer for preventing arterial stenosis.

24

EXAMPLE 8

Use of VEGF-C Polypeptides to Reduce or Prevent Restenosis

The procedures described in Example 1 are repeated except, instead of treating the test animals with an adenovirus containing a VEGF-C transgene or lacZ control, the animals are treated with a composition comprising a VEGF-C polypeptide in a pharmaceutically acceptable carrier (e.g., isotonic saline with serum albumin), or with carrier solution alone as a control. Test animals receive either 10, 100, 250, 500, 1000, or 5000 μ g of a VEGF-C polypeptide via intra-arterial infusion, e.g., as described in Example 1. A second group of animals additionally receive an injection of the VEGF-C polypeptide 7 days later. The animals are sacrificed and histological examination performed as described in Example 1. Reduced I/M ratio in the VEGF-C-treated animals versus control animals provides evidence of the therapeutic efficacy of VEGF-C polypeptide treatment. Repetition of the experiment using various sustained-release VEGF-C formulations and materials as described above is expected to further enhance the therapeutic efficacy of the VEGF-C polypeptide. Moreover, a treatment regimen comprising the simultaneous administration of VEGF-C protein (to provide immediate therapy to the target vessel) with a VEGF-C transgene (to provide sustained therapy for several days or weeks) is specifically contemplated as a variation of the invention.

EXAMPLE 9

Anti-Stenosis/Anti-Restenosis Activity of VEGF-D

The procedures described in the preceding examples are repeated using a composition comprising a VEGF-D polynucleotide or VEGF-D polypeptide in lieu of the VEGF-C polynucleotide/polypeptide, to demonstrate the ability of VEGF-D to prevent stenosis or restenosis of a blood vessel.

While the present invention has been described in terms of specific embodiments, it is understood that variations and modifications will occur to those in the art, all of which are intended as aspects of the present invention. Accordingly, only such limitations as appear in the claims should be placed on the invention.

SEQUENCE LISTING

<160> NUMBER OF SEQ ID NOS: 18

<210> SEQ ID NO 1

<211> LENGTH: 1997

<212> TYPE: DNA

<213> ORGANISM: Homo sapiens

<220> FEATURE:

<221> NAME/KEY: CDS

<222> LOCATION: (352)..(1608)

<400> SEQUENCE: 1

cccgccccgc ctctccaaaa agctacaccg acgcggaccg cggcggcgctc etccctcgcc 60

ctcgcttca ctcgccccgc ccgaatgccc ggagctegga tctccggtt cctgtgagcc 120

ttttacctga caccgcgcc ctttccccgg cactggctgg gagggcgccc tgcaaagtgt 180

ggaacgcgga gcccccgaac cgctccccgc gcctccggct cgcacagggg gggtcgccgg 240

-continued

gaggagcccg ggggagaggg accagagagg gcccgcggcc tcgcaggggc gcccgcgccc	300
ccaccctgc ccccgcagc ggaccggctc cccaccccc gtccttccac c atg cac Met His 1	357
ttg ctg ggc ttc ttc tct gtg gcg tgt tct ctg ctc gcc gct gcg ctg Leu Leu Gly Phe Phe Ser Val Ala Cys Ser Leu Leu Ala Ala Ala Leu 5 10 15	405
ctc ccg ggt cct cgc gag gcg ccc gcc gcc gcc gcc gcc ttc gag tcc Leu Pro Gly Pro Arg Glu Ala Pro Ala Ala Ala Ala Ala Phe Glu Ser 20 25 30	453
gga ctc gac ctc tcg gac gcg gag ccc gac gcg ggc gag gcc acg gct Gly Leu Asp Leu Ser Asp Ala Glu Pro Asp Ala Gly Glu Ala Thr Ala 35 40 45 50	501
tat gca agc aaa gat ctg gag gag cag tta cgg tct gtg tcc agt gta Tyr Ala Ser Lys Thr Leu Glu Glu Gln Leu Arg Ser Val Ser Ser Val 55 60 65	549
gat gaa ctc atg act gta ctc tac cca gaa tat tgg aaa atg tac aag Asp Glu Leu Met Thr Val Leu Tyr Pro Glu Tyr Trp Lys Met Tyr Lys 70 75 80	597
tgt cag cta agg aaa gga ggc tgg caa cat aac aga gaa cag gcc aac Cys Gln Leu Arg Lys Gly Gly Trp Gln His Asn Arg Glu Gln Ala Asn 85 90 95	645
ctc aac tca agg aca gaa gag act ata aaa ttt gct gca gca cat tat Leu Asn Ser Arg Thr Glu Glu Thr Ile Lys Phe Ala Ala Ala His Tyr 100 105 110	693
aat aca gag atc ttg aaa agt att gat aat gag tgg aga aag act caa Asn Thr Glu Ile Leu Lys Ser Ile Asp Asn Glu Trp Arg Lys Thr Gln 115 120 125 130	741
tgc atg cca cgg gag gtg tgt ata gat gtg ggg aag gag ttt gga gtc Cys Met Pro Arg Glu Val Cys Ile Asp Val Gly Lys Glu Phe Gly Val 135 140 145	789
gcg aca aac acc ttc ttt aaa cct cca tgt gtg tcc gtc tac aga tgt Ala Thr Asn Thr Phe Phe Lys Pro Pro Cys Val Ser Val Tyr Arg Cys 150 155 160	837
ggg ggt tgc tgc aat agt gag ggg ctg cag tgc atg aac acc agc acg Gly Gly Cys Cys Asn Ser Glu Gly Leu Gln Cys Met Asn Thr Ser Thr 165 170 175	885
agc tac ctc agc aag acg tta ttt gaa att aca gtg cct ctc tct caa Ser Tyr Leu Ser Lys Thr Leu Phe Glu Ile Thr Val Pro Leu Ser Gln 180 185 190	933
ggc ccc aaa cca gta aca atc agt ttt gcc aat cac act tcc tgc cga Gly Pro Lys Pro Val Thr Ile Ser Phe Ala Asn His Thr Ser Cys Arg 195 200 205 210	981
tgc atg tct aaa ctg gat gtt tac aga caa gtt cat tcc att att aga Cys Met Ser Lys Leu Asp Val Tyr Arg Gln Val His Ser Ile Ile Arg 215 220 225	1029
cgt tcc ctg cca gca aca cta cca cag tgt cag gca gcg aac aag acc Arg Ser Leu Pro Ala Thr Leu Pro Gln Cys Gln Ala Ala Asn Lys Thr 230 235 240	1077
tgc ccc acc aat tac atg tgg aat aat cac atc tgc aga tgc ctg gct Cys Pro Thr Asn Tyr Met Trp Asn Asn His Ile Cys Arg Cys Leu Ala 245 250 255	1125
cag gaa gat ttt atg ttt tcc tcg gat gct gga gat gac tca aca gat Gln Glu Asp Phe Met Phe Ser Ser Asp Ala Gly Asp Asp Ser Thr Asp 260 265 270	1173
gga ttc cat gac atc tgt gga cca aac aag gag ctg gat gaa gag acc Gly Phe His Asp Ile Cys Gly Pro Asn Lys Glu Leu Asp Glu Glu Thr 275 280 285 290	1221
tgt cag tgt gtc tgc aga gcg ggg ctt cgg cct gcc agc tgt gga ccc	1269

-continued

Cys	Gln	Cys	Val	Cys	Arg	Ala	Gly	Leu	Arg	Pro	Ala	Ser	Cys	Gly	Pro	
				295					300					305		
cac	aaa	gaa	cta	gac	aga	aac	tca	tgc	cag	tgt	gtc	tgt	aaa	aac	aaa	1317
His	Lys	Glu	Leu	Asp	Arg	Asn	Ser	Cys	Gln	Cys	Val	Cys	Lys	Asn	Lys	
			310					315					320			
ctc	ttc	ccc	agc	caa	tgt	ggg	gcc	aac	cga	gaa	ttt	gat	gaa	aac	aca	1365
Leu	Phe	Pro	Ser	Gln	Cys	Gly	Ala	Asn	Arg	Glu	Phe	Asp	Glu	Asn	Thr	
			325				330					335				
tgc	cag	tgt	gta	tgt	aaa	aga	acc	tgc	ccc	aga	aat	caa	ccc	cta	aat	1413
Cys	Gln	Cys	Val	Cys	Lys	Arg	Thr	Cys	Pro	Arg	Asn	Gln	Pro	Leu	Asn	
		340				345					350					
cct	gga	aaa	tgt	gcc	tgt	gaa	tgt	aca	gaa	agt	cca	cag	aaa	tgc	ttg	1461
Pro	Gly	Lys	Cys	Ala	Cys	Glu	Cys	Thr	Glu	Ser	Pro	Gln	Lys	Cys	Leu	
	355				360					365					370	
tta	aaa	gga	aag	aag	ttc	cac	cac	caa	aca	tgc	agc	tgt	tac	aga	cgg	1509
Leu	Lys	Gly	Lys	Lys	Phe	His	His	Gln	Thr	Cys	Ser	Cys	Tyr	Arg	Arg	
				375					380					385		
cca	tgt	acg	aac	cgc	cag	aag	gct	tgt	gag	cca	gga	ttt	tca	tat	agt	1557
Pro	Cys	Thr	Asn	Arg	Gln	Lys	Ala	Cys	Glu	Pro	Gly	Phe	Ser	Tyr	Ser	
			390					395					400			
gaa	gaa	gtg	tgt	cgt	tgt	gtc	cct	tca	tat	tgg	aaa	aga	cca	caa	atg	1605
Glu	Glu	Val	Cys	Arg	Cys	Val	Pro	Ser	Tyr	Trp	Lys	Arg	Pro	Gln	Met	
		405				410						415				
agc	taagattgta	ctgttttcca	gttcatcgat	tttctattat	ggaaaactgt											1658
Ser																
gttgccacag	tagaactgtc	tgtgaacaga	gagacccttg	tgggtccatg	ctaacaaga											1718
caaaagtctg	tctttcctga	accatgtgga	taactttaca	gaaatggact	ggagctcatc											1778
tgcaaaaggc	ctcttgtaaa	gactggtttt	ctgccaatga	ccaacagcc	aagattttcc											1838
tcttgtgatt	tctttaaag	aatgactata	taatttattt	ccactaaaa	tattgtttct											1898
gcattcattt	ttagatgaac	aacaattggt	aaaactcact	gtgatcaata	tttttatatc											1958
atgcaaaaata	tgtttaaagt	aaaatgaaaa	ttgtattat													1997

<210> SEQ ID NO 2

<211> LENGTH: 419

<212> TYPE: PRT

<213> ORGANISM: Homo sapiens

<400> SEQUENCE: 2

Met	His	Leu	Leu	Gly	Phe	Phe	Ser	Val	Ala	Cys	Ser	Leu	Leu	Ala	Ala	
1				5					10					15		
Ala	Leu	Leu	Pro	Gly	Pro	Arg	Glu	Ala	Pro	Ala	Ala	Ala	Ala	Ala	Phe	
			20					25						30		
Glu	Ser	Gly	Leu	Asp	Leu	Ser	Asp	Ala	Glu	Pro	Asp	Ala	Gly	Glu	Ala	
		35					40					45				
Thr	Ala	Tyr	Ala	Ser	Lys	Asp	Leu	Glu	Glu	Gln	Leu	Arg	Ser	Val	Ser	
		50				55						60				
Ser	Val	Asp	Glu	Leu	Met	Thr	Val	Leu	Tyr	Pro	Glu	Tyr	Trp	Lys	Met	
		65			70					75				80		
Tyr	Lys	Cys	Gln	Leu	Arg	Lys	Gly	Gly	Trp	Gln	His	Asn	Arg	Glu	Gln	
			85						90					95		
Ala	Asn	Leu	Asn	Ser	Arg	Thr	Glu	Glu	Thr	Ile	Lys	Phe	Ala	Ala	Ala	
		100						105					110			
His	Tyr	Asn	Thr	Glu	Ile	Leu	Lys	Ser	Ile	Asp	Asn	Glu	Trp	Arg	Lys	
		115					120					125				
Thr	Gln	Cys	Met	Pro	Arg	Glu	Val	Cys	Ile	Asp	Val	Gly	Lys	Glu	Phe	
	130					135						140				

-continued

Gly Val Ala Thr Asn Thr Phe Phe Lys Pro Pro Cys Val Ser Val Tyr
 145 150 155 160
 Arg Cys Gly Gly Cys Cys Asn Ser Glu Gly Leu Gln Cys Met Asn Thr
 165 170 175
 Ser Thr Ser Tyr Leu Ser Lys Thr Leu Phe Glu Ile Thr Val Pro Leu
 180 185 190
 Ser Gln Gly Pro Lys Pro Val Thr Ile Ser Phe Ala Asn His Thr Ser
 195 200 205
 Cys Arg Cys Met Ser Lys Leu Asp Val Tyr Arg Gln Val His Ser Ile
 210 215 220
 Ile Arg Arg Ser Leu Pro Ala Thr Leu Pro Gln Cys Gln Ala Ala Asn
 225 230 235 240
 Lys Thr Cys Pro Thr Asn Tyr Met Trp Asn Asn His Ile Cys Arg Cys
 245 250 255
 Leu Ala Gln Glu Asp Phe Met Phe Ser Ser Asp Ala Gly Asp Asp Ser
 260 265 270
 Thr Asp Gly Phe His Asp Ile Cys Gly Pro Asn Lys Glu Leu Asp Glu
 275 280 285
 Glu Thr Cys Gln Cys Val Cys Arg Ala Gly Leu Arg Pro Ala Ser Cys
 290 295 300
 Gly Pro His Lys Glu Leu Asp Arg Asn Ser Cys Gln Cys Val Cys Lys
 305 310 315 320
 Asn Lys Leu Phe Pro Ser Gln Cys Gly Ala Asn Arg Glu Phe Asp Glu
 325 330 335
 Asn Thr Cys Gln Cys Val Cys Lys Arg Thr Cys Pro Arg Asn Gln Pro
 340 345 350
 Leu Asn Pro Gly Lys Cys Ala Cys Glu Cys Thr Glu Ser Pro Gln Lys
 355 360 365
 Cys Leu Leu Lys Gly Lys Lys Phe His His Gln Thr Cys Ser Cys Tyr
 370 375 380
 Arg Arg Pro Cys Thr Asn Arg Gln Lys Ala Cys Glu Pro Gly Phe Ser
 385 390 395 400
 Tyr Ser Glu Glu Val Cys Arg Cys Val Pro Ser Tyr Trp Lys Arg Pro
 405 410 415
 Gln Met Ser

<210> SEQ ID NO 3
 <211> LENGTH: 2029
 <212> TYPE: DNA
 <213> ORGANISM: Homo sapiens
 <220> FEATURE:
 <221> NAME/KEY: CDS
 <222> LOCATION: (411)..(1475)

<400> SEQUENCE: 3

gttgggttcc agctttctgt agctgtaagc attggtggcc acaccacctc cttacaaagc 60
 aactagaacc tgcggcatac attggagaga tttttttaat tttctggaca tgaagtaaat 120
 ttagagtgct ttctaatttc aggtagaaga catgtccacc ttctgattat ttttgagaa 180
 cattttgatt tttttcatct ctctctcccc acccctaaga ttgtgcaaaa aaagcgtacc 240
 ttgcctaatt gaaataatct cattggattt tgatcagaac tgattatttg gttttctgtg 300
 tgaagttttg aggtttcaaa ctttccttct ggagaatgcc ttttgaaaca attttctcta 360
 gctgcctgat gtcaactgct tagtaatcag tggatattga aatattcaaa atg tac 416
 Met Tyr

-continued

aga gag tgg gta gtg gtg aat gtt ttc atg atg ttg tac gtc cag ctg Arg Glu Trp Val Val Val Asn Val Phe Met Met Leu Tyr Val Gln Leu 5 10 15	464
gtg cag ggc tcc agt aat gaa cat gga cca gtg aag cga tca tct cag Val Gln Gly Ser Ser Asn Glu His Gly Pro Val Lys Arg Ser Ser Gln 20 25 30	512
tcc aca ttg gaa cga tct gaa cag cag atc agg gct gct tct agt ttg Ser Thr Leu Glu Arg Ser Glu Gln Gln Ile Arg Ala Ala Ser Ser Leu 35 40 45 50	560
gag gaa cta ctt cga att act cac tct gag gac tgg aag ctg tgg aga Glu Glu Leu Leu Arg Ile Thr His Ser Glu Asp Trp Lys Leu Trp Arg 55 60 65	608
tgc agg ctg agg ctc aaa agt ttt acc agt atg gac tct cgc tca gca Cys Arg Leu Arg Leu Lys Ser Phe Thr Ser Met Asp Ser Arg Ser Ala 70 75 80	656
tcc cat cgg tcc act agg ttt gcg gca act ttc tat gac att gaa aca Ser His Arg Ser Thr Arg Phe Ala Ala Thr Phe Tyr Asp Ile Glu Thr 85 90 95	704
cta aaa gtt ata gat gaa gaa tgg caa aga act cag tgc agc cct aga Leu Lys Val Ile Asp Glu Glu Trp Gln Arg Thr Gln Cys Ser Pro Arg 100 105 110	752
gaa acg tgc gtg gag gtg gcc agt gag ctg ggg aag agt acc aac aca Glu Thr Cys Val Glu Val Ala Ser Glu Leu Gly Lys Ser Thr Asn Thr 115 120 125 130	800
ttc ttc aag ccc cct tgt gtg aac gtg ttc cga tgt ggt ggc tgt tgc Phe Phe Lys Pro Pro Cys Val Asn Val Phe Arg Cys Gly Gly Cys Cys 135 140 145	848
aat gaa gag agc ctt atc tgt atg aac acc agc acc tgc tac att tcc Asn Glu Glu Ser Leu Ile Cys Met Asn Thr Ser Thr Ser Tyr Ile Ser 150 155 160	896
aaa cag ctc ttt gag ata tca gtg cct ttg aca tca gta cct gaa tta Lys Gln Leu Phe Glu Ile Ser Val Pro Leu Thr Ser Val Pro Glu Leu 165 170 175	944
gtg cct gtt aaa gtt gcc aat cat aca ggt tgt aag tgc ttg cca aca Val Pro Val Lys Val Ala Asn His Thr Gly Cys Lys Cys Leu Pro Thr 180 185 190	992
gcc ccc cgc cat cca tac tca att atc aga aga tcc atc cag atc cct Ala Pro Arg His Pro Tyr Ser Ile Ile Arg Arg Ser Ile Gln Ile Pro 195 200 205 210	1040
gaa gaa gat cgc tgt tcc cat tcc aag aaa ctc tgt cct att gac atg Glu Glu Asp Arg Cys Ser His Ser Lys Lys Leu Cys Pro Ile Asp Met 215 220 225	1088
cta tgg gat agc aac aaa tgt aaa tgt gtt ttg cag gag gaa aat cca Leu Trp Asp Ser Asn Lys Cys Lys Cys Val Leu Gln Glu Glu Asn Pro 230 235 240	1136
ctt gct gga aca gaa gac cac tct cat ctc cag gaa cca gct ctc tgt Leu Ala Gly Thr Glu Asp His Ser His Leu Gln Glu Pro Ala Leu Cys 245 250 255	1184
ggg cca cac atg atg ttt gac gaa gat cgt tgc gag tgt gtc tgt aaa Gly Pro His Met Met Phe Asp Glu Asp Arg Cys Glu Cys Val Cys Lys 260 265 270	1232
aca cca tgt ccc aaa gat cta atc cag cac ccc aaa aac tgc agt tgc Thr Pro Cys Pro Lys Asp Leu Ile Gln His Pro Lys Asn Cys Ser Cys 275 280 285 290	1280
ttt gag tgc aaa gaa agt ctg gag acc tgc tgc cag aag cac aag cta Phe Glu Cys Lys Glu Ser Leu Glu Thr Cys Cys Gln Lys His Lys Leu 295 300 305	1328
ttt cac cca gac acc tgc agc tgt gag gac aga tgc ccc ttt cat acc Phe His Pro Asp Thr Cys Ser Cys Glu Asp Arg Cys Pro Phe His Thr 310 315 320	1376

-continued

```

aga cca tgt gca agt ggc aaa aca gca tgt gca aag cat tgc cgc ttt 1424
Arg Pro Cys Ala Ser Gly Lys Thr Ala Cys Ala Lys His Cys Arg Phe
      325                330                335

cca aag gag aaa agg gct gcc cag ggg ccc cac agc cga aag aat cct 1472
Pro Lys Glu Lys Arg Ala Ala Gln Gly Pro His Ser Arg Lys Asn Pro
      340                345                350

tga ttcagcgttc caagttcccc atccctgtca tttttaacag catgctgctt 1525

tgccaagttg ctgtcactgt ttttttccca ggtgttaaaa aaaaaatcca ttttacacag 1585

caccacagtg aatccagacc aaccttccat tcacaccagc taaggagtcc ctggttcatt 1645

gatggatgtc ttctagctgc agatgcctct gcgcaccaag gaatggagag gaggggaccc 1705

atgtaatcct tttgtttagt tttgtttttg ttttttggtg aatgagaaaag gtgtgctggt 1765

catggaatgg caggtgtcat atgactgatt actcagagca gatgaggaaa actgtagtct 1825

ctgagtcctt tgctaatcgc aactcttctg aattattctg attctttttt atgcagaatt 1885

tgattcgtat gatcagtaact gactttctga ttaactgtcca gcttatagtc ttccagttta 1945

atgaactacc atctgatggt tcatatttaa gtgtatttaa agaaaataaa caccattatt 2005

caagccaaaa aaaaaaaaaa aaaa 2029

```

<210> SEQ ID NO 4

<211> LENGTH: 354

<212> TYPE: PRT

<213> ORGANISM: Homo sapiens

<400> SEQUENCE: 4

```

Met Tyr Arg Glu Trp Val Val Val Asn Val Phe Met Met Leu Tyr Val
  1          5          10          15

Gln Leu Val Gln Gly Ser Ser Asn Glu His Gly Pro Val Lys Arg Ser
      20          25          30

Ser Gln Ser Thr Leu Glu Arg Ser Glu Gln Gln Ile Arg Ala Ala Ser
      35          40          45

Ser Leu Glu Glu Leu Leu Arg Ile Thr His Ser Glu Asp Trp Lys Leu
      50          55          60

Trp Arg Cys Arg Leu Arg Leu Lys Ser Phe Thr Ser Met Asp Ser Arg
      65          70          75          80

Ser Ala Ser His Arg Ser Thr Arg Phe Ala Ala Thr Phe Tyr Asp Ile
      85          90          95

Glu Thr Leu Lys Val Ile Asp Glu Glu Trp Gln Arg Thr Gln Cys Ser
      100          105          110

Pro Arg Glu Thr Cys Val Glu Val Ala Ser Glu Leu Gly Lys Ser Thr
      115          120          125

Asn Thr Phe Phe Lys Pro Pro Cys Val Asn Val Phe Arg Cys Gly Gly
      130          135          140

Cys Cys Asn Glu Glu Ser Leu Ile Cys Met Asn Thr Ser Thr Ser Tyr
      145          150          155          160

Ile Ser Lys Gln Leu Phe Glu Ile Ser Val Pro Leu Thr Ser Val Pro
      165          170          175

Glu Leu Val Pro Val Lys Val Ala Asn His Thr Gly Cys Lys Cys Leu
      180          185          190

Pro Thr Ala Pro Arg His Pro Tyr Ser Ile Ile Arg Arg Ser Ile Gln
      195          200          205

Ile Pro Glu Glu Asp Arg Cys Ser His Ser Lys Lys Leu Cys Pro Ile
      210          215          220

Asp Met Leu Trp Asp Ser Asn Lys Cys Lys Cys Val Leu Gln Glu Glu

```

-continued

225	230	235	240
Asn Pro Leu Ala Gly Thr Glu Asp His Ser His Leu Gln Glu Pro Ala	245	250	255
Leu Cys Gly Pro His Met Met Phe Asp Glu Asp Arg Cys Glu Cys Val	260	265	270
Cys Lys Thr Pro Cys Pro Lys Asp Leu Ile Gln His Pro Lys Asn Cys	275	280	285
Ser Cys Phe Glu Cys Lys Glu Ser Leu Glu Thr Cys Cys Gln Lys His	290	295	300
Lys Leu Phe His Pro Asp Thr Cys Ser Cys Glu Asp Arg Cys Pro Phe	305	310	315
His Thr Arg Pro Cys Ala Ser Gly Lys Thr Ala Cys Ala Lys His Cys	325	330	335
Arg Phe Pro Lys Glu Lys Arg Ala Ala Gln Gly Pro His Ser Arg Lys	340	345	350

Asn Pro

<210> SEQ ID NO 5
 <211> LENGTH: 20
 <212> TYPE: DNA
 <213> ORGANISM: Artificial Sequence
 <220> FEATURE:
 <223> OTHER INFORMATION: Description of Artificial Sequence: primer

<400> SEQUENCE: 5

ttggaggcct aggettttgc 20

<210> SEQ ID NO 6
 <211> LENGTH: 20
 <212> TYPE: DNA
 <213> ORGANISM: Artificial Sequence
 <220> FEATURE:
 <223> OTHER INFORMATION: Description of Artificial Sequence: primer

<400> SEQUENCE: 6

atactgtcgt cgtcccctca 20

<210> SEQ ID NO 7
 <211> LENGTH: 22
 <212> TYPE: DNA
 <213> ORGANISM: Artificial Sequence
 <220> FEATURE:
 <223> OTHER INFORMATION: Description of Artificial Sequence: primer

<400> SEQUENCE: 7

ggtagaagac cccaaggact tt 22

<210> SEQ ID NO 8
 <211> LENGTH: 17
 <212> TYPE: DNA
 <213> ORGANISM: Artificial Sequence
 <220> FEATURE:
 <223> OTHER INFORMATION: Description of Artificial Sequence: primer

<400> SEQUENCE: 8

cgccattcgc cattcag 17

<210> SEQ ID NO 9
 <211> LENGTH: 18
 <212> TYPE: DNA
 <213> ORGANISM: Artificial Sequence
 <220> FEATURE:
 <223> OTHER INFORMATION: Description of Artificial Sequence: primer

-continued

<400> SEQUENCE: 9
ctgcttactg gcttateg 18

<210> SEQ ID NO 10
<211> LENGTH: 20
<212> TYPE: DNA
<213> ORGANISM: Artificial Sequence
<220> FEATURE:
<223> OTHER INFORMATION: Description of Artificial Sequence: primer

<400> SEQUENCE: 10
cctgttctct gttatgttgc 20

<210> SEQ ID NO 11
<211> LENGTH: 19
<212> TYPE: DNA
<213> ORGANISM: Artificial Sequence
<220> FEATURE:
<223> OTHER INFORMATION: Description of Artificial Sequence: primer

<400> SEQUENCE: 11
tctccaaaaa gctacaccg 19

<210> SEQ ID NO 12
<211> LENGTH: 18
<212> TYPE: DNA
<213> ORGANISM: Artificial Sequence
<220> FEATURE:
<223> OTHER INFORMATION: Description of Artificial Sequence: primer

<400> SEQUENCE: 12
caagtgcacg gtggaagg 18

<210> SEQ ID NO 13
<211> LENGTH: 20
<212> TYPE: DNA
<213> ORGANISM: Artificial Sequence
<220> FEATURE:
<223> OTHER INFORMATION: Description of Artificial Sequence: primer

<400> SEQUENCE: 13
tcgatccatg aactttctgc 20

<210> SEQ ID NO 14
<211> LENGTH: 20
<212> TYPE: DNA
<213> ORGANISM: Artificial Sequence
<220> FEATURE:
<223> OTHER INFORMATION: Description of Artificial Sequence: primer

<400> SEQUENCE: 14
ttcgtttaac tcaagctgcc 20

<210> SEQ ID NO 15
<211> LENGTH: 19
<212> TYPE: DNA
<213> ORGANISM: Artificial Sequence
<220> FEATURE:
<223> OTHER INFORMATION: Description of Artificial Sequence: primer

<400> SEQUENCE: 15
gaccctggct ttactgctg 19

<210> SEQ ID NO 16
<211> LENGTH: 20

-continued

<212> TYPE: DNA
 <213> ORGANISM: Artificial Sequence
 <220> FEATURE:
 <223> OTHER INFORMATION: Description of Artificial Sequence: primer

 <400> SEQUENCE: 16

 ggaacattta cacgtctgcg 20

 <210> SEQ ID NO 17
 <211> LENGTH: 2679
 <212> TYPE: DNA
 <213> ORGANISM: Artificial Sequence
 <220> FEATURE:
 <223> OTHER INFORMATION: Description of Artificial Sequence: chimeric
 sequence in which CMV promoter sequence is ligated
 to Homo sapien VEGF-C sequence

 <400> SEQUENCE: 17

 cgttgacatt gattattgac tagttattaa tagtaatcaa ttacggggtc attagttcat 60
 agcccatata tggagttccg cgttacataa cttacggtaa atggcccgc tggctgaccg 120
 cccaacgacc cccgccatt gacgtcaata atgacgatg ttcccatagt aacgccaata 180
 gggactttcc attgacgtca atgggtggac tatttacggg aaactgcca cttggcagta 240
 catcaagtgt atcatatgcc aagtacgcc cctattgacg tcaatgacgg taaatggccc 300
 gcttggcatt atgcccagta catgacctta tgggactttc ctacttggca gtacatctac 360
 gtattagtea tcgctattac catgggtgat cggttttggc agtacatcaa tgggcgtgga 420
 tagcggtttg actcacgggg atttccaagt ctccaccca ttgacgtcaa tgggagtttg 480
 ttttggcacc aaaatcaacg ggactttcca aaatgtcgta acaactccgc cccattgacg 540
 caaatggcgc gtaggcgtgt acgggtggag gtctatataa gcagagctct ctggctaact 600
 agagaaccca ctgcttactg gcttatcgaa attaatacga ctcaactatg ggagacccaa 660
 gctggctagc gtttaaaact aacccgcccc gcctctcaa aaagctacac cgacgcggac 720
 cgcgccggcg tcctccctcg cctcgcctc acctcgcggg ctccgaatgc ggggagctcg 780
 gatgtccggt ttctctgtgag gcttttacct gacacccgcc gcctttcccc ggcactggct 840
 gggagggcgc cctgcaaagt tgggaacgcg gagccccgga cccgctcccc ccgctcccg 900
 ctgccccagg gggggtcgcc gggaggagcc cgggggagag ggaccaggag gggcccgcg 960
 cctcgcaggg gcgcccgcgc cccccccct gcccccgcca gcggaccggg ccccccccc 1020
 cggctcctcc accatgcaact tgctgggctt cttctctgtg gcgtgttctc tgctcgcgc 1080
 tgcgctgctc ccgggtctc gcgaggcgc ccgcccgcgc gccgccttcg agtccggact 1140
 cgacctctcg gacccggagc ccgacgcggg cgaggccacg gcttatgcaa gcaaagatct 1200
 ggaggagcag ttacggctctg tgtccagtgt agatgaactc atgactgtac tctaccaga 1260
 atattgaaa atgtacaagt gtcagctaag gaaaggaggc tggcaacata acagagaaca 1320
 ggccaacctc aactcaagga cagaagagac tataaaattt gctgcagcac attataatac 1380
 agagatcttg aaaagtattg ataatgagtg gagaagact caatgcatgc cacgggaggt 1440
 gtgtatagat gtggggaagg agtttggagt cgcgacaaac accttcttta aacctccatg 1500
 tgtgtccgtc tacagatgtg ggggttctg caatagttag gggctgcagt gcatgaacac 1560
 cagcacgagc tacctcagca agacgttatt tgaaattaca gtgcctctct ctcaaggccc 1620
 caaacagta acaatcagtt ttgccaatca cacttctgc cgatgcatgt ctaaactgga 1680
 tgtttacaga caagttcatt ccattattag acgttccctg ccagcaacac taccacagtg 1740
 tcaggcagcg aacaagacct gccccacaa ttacatgtgg aataatcaca tctgcagatg 1800

-continued

cctggctcag gaagatttta tgttttctc ggatgctgga gatgactcaa cagatggatt	1860
ccatgacatc tgtggaccaa acaaggagct ggatgaagag acctgtcagt gtgtctgcag	1920
agcggggctt cggcctgcc gctgtggacc ccacaaagaa ctagacagaa actcatgcc	1980
gtgtgtctgt aaaaacaaac tcttccccag ccaatgtggg gccaacccag aatttgatga	2040
aaacacatgc cagtgtgtat gtaaaagaac ctgcccaga aatcaacccc taaatcctgg	2100
aaaatgtgcc tgtgaatgta cagaaagtcc acagaaatgc ttgttaaaag gaaagaagtt	2160
ccaccaccaa acatgcagct gttacagacg gccatgtacg aaccgccaga aggcttgtga	2220
gccaggattt tcatatagtg aagaagtgtg tcggtgtgtc ccttcatatt ggaaaagacc	2280
acaaatgagc taagattgta ctgttttcca gttcatcgat tttctattat ggaaaactgt	2340
gttgccacag tagaactgtc tgtgaacaga gagacccttg tgggtccatg ctaacaaaga	2400
caaaagtctg tctttctga accatgtgga taactttaca gaaatggact ggagctcatc	2460
tgcaaaaggc ctcttgtaaa gactggttt ctgccaatga ccaaacagcc aagattttcc	2520
tcttgtgatt tctttaaag aatgactata taatttattt ccaactaaaa tattgtttct	2580
gcattcattt ttatagcaac acaattgggt aaaactcact gtgatcaata tttttatc	2640
atgcaaaata tgtttaaata aaaatgaaaa ttgtattat	2679

<210> SEQ ID NO 18

<211> LENGTH: 2240

<212> TYPE: DNA

<213> ORGANISM: Mus musculus

<400> SEQUENCE: 18

tgtttagaag atgaaccgta agcctaggct agaactgagg gagcctacta ctcccaccct	60
tccgaggggt ggcggcagga ctgggcagct ggcctaccta cctttctgaa tgetagggta	120
ggtttgaatc accatgcog cctggcccgc ttctgcccc attggcacc tggcttcagt	180
tccctggcaa catctctgtg tgtgtgtgtg tgtgtgagag agagagatca ggaggaacaa	240
gggcctctgt ctgccagca gttgtctctc cttcagggct ctgccagact acacagtgca	300
tacgtggggt tccacagtc gtctcactcc ccgccactga ctaactccag aactccacc	360
ccgttctcag tgccacaaat ttggtgccaa attctctcca gagaagcctc tctggaaact	420
tcccagagga tcccattcac cccagggccc tagctcctga tgactgcaga tcagacaagg	480
gctcagataa gcatactccc cccccccgt aacccctcc ccacataaa acctacagtt	540
atgcttccga ggtcaaacac gcaactttt ggggtgtgtg gtatgtcaga aacacgcaat	600
tatttgggag ctcaaaagtct gccgcactca agaatcatct ctcaccccct ttccaagacc	660
cgtgccattt gagcaagagt tgggtgtgtc ataatgtagt cactaggggg cgctcggcca	720
tcacggggag atcgtaaact gggcgagccg agtctgcgtg agggaggacg cgtgtttcaa	780
tgtgagtgcg tgcattgtgt gtgtgtgtgt gtagtgtgtg tgtgaggtgg gggagaaagc	840
caggggtcac tctagttgtc cctatcctca tacgttctctg ccagctctcc gccttccaac	900
ccctactttc tcctatatcc tgggaaaggg aattgtctta gacctgtcc gcatataacc	960
tcaactctct gtctcccctg attcccaata ctctgggatt cccagtgtgt tctgagccc	1020
atttgaaggg gtgcacagat aattttgagg ccgtggaccc tggtaagggg tttagctttc	1080
catttcgcgg tagtggccta ggggctcccc gaaaggcggg gcctggctcc accagaccgt	1140
ccccggggcg ggtctgggag gggcttgggg gtggagctag atttctctt tttcttccac	1200
cgctgttaac ggtgagaagc gcagaggett ggggcagccg agctgcagcg agcgcggcgc	1260

-continued

actgggggag agctgagcgg cggcagcggg gctctgtcgc gagacgcagc gacaaggcag	1320
actatcagcg gactcaccag cccgggagtc tgtgctctgg gatttgatat tcaaacctct	1380
taattttttt ttcttaaact gtattgtttt acgctttaat ttatttttgc ttctatttc	1440
cctcttaaat cgtgccaaac gtttgaggag gttggttctt cactccctca aatcaacttcg	1500
gattgtggaa atcagcagac gaaagaggta tcaagagctc cagagagaag tcaaggaaga	1560
gagagagaga cggtcagag agagcgcgct ggcgagcga cagagagagg gacaggggca	1620
aagttgactt gaccttgctt ttgggggtga ccgccagagc gcggcgtgac ctcccccttc	1680
gatcttgcac cggaccagtc gcgctgacgg acagacagac agacaccgcc cccagcccca	1740
gcgccacct cctcgccggc gggctgccga cggtgagcgc ggcggcgagc cgagaaaccg	1800
aagcccgccg ccggaggcgg gtggaggggg tcggggctcg cgggattgca cggaaacttt	1860
tcgtccaact tctgggctct tctcgctccg tagtagccgt ggtctgcgcc gcaggagaca	1920
aaccgatccg gagctgggag aaggctagct cggccctgga gaggcggggg cccgagaaga	1980
gaggggagga aggaagagga gagggggcca cagtgggcgc tcggctctca ggagccgagc	2040
tcatggacgg gtgaggcggc cgtgtgcgca gacagtgtc cagccgcgcg cgcgccccag	2100
gccccggccc gggcctcggg tcacagaagg agaggagccc gccaaaggcg gcaagagagc	2160
gggctgcctc gcagtcggga gccggagaga gggagcgcga gccgcccggg ccccgagcgg	2220
cctccgaaac catgaacttt	2240

What is claimed is:

1. A method of treating a mammalian subject in need of treatment to inhibit stenosis or restenosis of a blood vessel, comprising the step of:

administering directly to the blood vessel a composition comprising a polynucleotide, the polynucleotide comprising a nucleotide sequence that encodes a polypeptide operatively linked to a promoter for expression of the polypeptide in cells of the blood vessel,

wherein the encoded polypeptide comprises an amino acid sequence selected from the group consisting of:

(a) the amino acid sequence of SEQ ID NO: 4; and

(b) a fragment of (a) wherein the fragment comprises amino acids 93-201 of SEQ ID NO: 4 and binds to and stimulates phosphorylation of VEGFR-2 or VEGFR-3, and

wherein said polypeptide expressed by the cells of the blood vessel inhibits stenosis or restenosis of said blood vessel.

2. The method of claim 1 wherein the polypeptide encoded by said polynucleotide comprises the fragment of SEQ ID NO: 4, said fragment comprising amino acids 93-201 of SEQ ID NO: 4.

3. The method of claim 1 or 2 wherein said mammalian subject is a human.

4. The method of claim 1 or 2 wherein said polynucleotide further comprises a nucleotide sequence encoding a secretory signal peptide, and wherein the sequence encoding the secretory signal peptide is operably linked to the promoter and connected in-frame with the sequence that encodes the polypeptide.

5. The method of claim 4 wherein said encoded polypeptide lacks amino acids 1 to 92 of SEQ ID NO: 4 and lacks amino acids 202 to 354 of SEQ ID NO: 4.

6. The method of claim 4 wherein the signal sequence is a heterologous signal sequence.

7. The method of claim 1 or 2 wherein the composition comprises a gene therapy vector comprising said polynucleotide, wherein the gene therapy vector is selected from the group consisting of a replication-deficient adenovirus, an adeno-associated virus, an adenovirus, a lipofectin-mediated gene transfer vector, a liposome, and a naked DNA plasmid.

8. The method of claim 7, wherein the composition is administered by a procedure or a device selected from the group consisting of a catheter mediated gene transfer, a balloon catheter, a coated catheter, a coated stent, and an extravascular collar.

9. The method of claim 7, wherein the vector comprises the replication deficient adenovirus administered at a titer of 10^7 - 10^{13} viral particles.

10. The method of claim 7 wherein the vector comprises the replication deficient adenovirus, and wherein the composition comprises the adenovirus administered at a titer of 10^9 - 10^{11} viral particles.

11. The method according to any one of claims 1 and 2, wherein the mammalian subject is a human subject in need of a surgery involving the blood vessel.

12. The method according to any one of claims 1 and 2 wherein the mammalian subject is a human subject and the polynucleotide is administered prophylactically to the blood vessel shortly before, and/or concurrently with and/or shortly after an angioplasty procedure or a procedure to perform a vascular graft.

13. The method according to claim 12, wherein the polynucleotide is administered with a device employed in the angioplasty selected from the group consisting of a catheter, a stent, an expandable elastic membrane, and combinations thereof.

45

14. The method according to claim 12, wherein the polynucleotide is administered with a device used in a vascular graft procedure.

15. The method according to claim 14, wherein the device is an extravascular collar.

16. The method of claim 1, wherein the encoded polypeptide comprises the amino acid sequence of SEQ ID NO: 4.

17. The method of claim 1 polypeptide comprises the amino acid sequence of SEQ ID NO: 4.

18. The method of claim 1 wherein the composition comprises a gene therapy vector, said gene therapy vector comprising said polynucleotide.

19. The method of claim 18 wherein the gene therapy vector comprises a replication deficient adenovirus, said adenovirus comprising the polynucleotide operably linked to the promoter and flanked by adenoviral polynucleotide sequences.

20. The method of any one of claim 17, or 18 wherein said mammalian subject is a human.

21. A method of treating a mammalian subject in need of treatment to inhibit restenosis of a blood vessel, comprising: identifying a mammalian subject with the blood vessel wherein the vessel has been treated for stenosis or will be treated for the stenosis; and directly administering to the mammalian subject at the site of the blood vessel a composition comprising a polynucleotide operatively linked to a promoter for expression of a polypeptide encoded by the polynucleotide to promote expression of the polypeptide in cells of the blood vessel,

wherein the encoded polypeptide comprises an amino acid sequence selected from the group consisting of:

- (a) the amino acid sequence of SEQ ID NO: 4; and
- (b) a fragment of (a) wherein the fragment comprises amino acids 93-201 of SEQ ID

NO: 4 and binds to and stimulates phosphorylation of VEGFR-2 or VEGFR-3, and

wherein the polypeptide expressed by the cells of the blood vessel inhibits restenosis of said blood vessel.

22. The method of claim 21 wherein the composition comprises a gene therapy vector comprising said polynucleotide, wherein the gene therapy vector is selected from the group consisting of a replication-deficient adenovirus, an adeno-associated virus, an adenovirus, a lipofectin-mediated gene transfer vector, a liposome, and a naked DNA plasmid.

23. The method of claim 21 wherein the administering is performed via a device selected from the group consisting of an intravascular stent; an intravascular catheter; a combination of an intravascular stent and catheter; an extravascular collar; and an elastomeric membrane adapted to cover a surface of an intravascular stent or catheter.

24. A method of treating a mammalian subject to inhibit stenosis or restenosis of a blood vessel graft, comprising:

administering to the mammalian subject at the site of the blood vessel graft a composition comprising a polynucleotide encoding a polypeptide operatively linked to a promoter for expression of the polypeptide encoded by the polynucleotide to promote expression of the polypeptide in blood vessel cells,

wherein the encoded polypeptide comprises an amino acid sequence selected from the group consisting of:

- (a) the amino acid sequence of SEQ ID NO: 4; and
- (b) a fragment of (a) wherein the fragment comprises amino acids 93-201 of SEQ ID NO: 4 and binds to and stimulates phosphorylation of VEGFR-2 or VEGFR-3, and

46

wherein expression of said polynucleotide in said blood vessel cells inhibits stenosis of said blood vessel graft.

25. The method according to claim 24, wherein the composition comprises a gene therapy vector comprising said polynucleotide, wherein the gene therapy vector is selected from the group consisting of a replication-deficient adenovirus, an adeno-associated virus, an adenovirus, a lipofectin-mediated gene transfer vector, a liposome, and a naked DNA plasmid.

26. The method of any one of claim 21, or 24, wherein the polypeptide encoded by said polynucleotide comprises the fragment of SEQ ID NO: 4, said fragment comprising amino acids 93-201 of SEQ ID NO: 4.

27. The method according to claim 26, wherein the mammalian subject is a human.

28. The method of any one of claim 21, or 24, wherein the composition is administered by a procedure or device selected from the group consisting of catheter mediated gene transfer, balloon catheter, coated catheter, coated stent, and extravascular collar.

29. An improvement in a medical device designed to contact a surface of a blood vessel in the course of surgery to inhibit stenosis or restenosis of the blood vessel, said improvement comprising integrating into the device a composition effective to prevent stenosis or restenosis, said composition comprising a polynucleotide operatively linked to a promoter for expression of a polypeptide encoded by the polynucleotide in cells of blood vessels,

wherein the device is selected from the group consisting of an intravascular stent; an intravascular catheter; a combination of an intravascular stent and catheter; an extravascular collar; and an elastomeric membrane adapted to cover a surface of an intravascular stent or catheter; and

wherein the encoded polypeptide comprises an amino acid sequence selected from the group consisting of:

- (a) the amino acid sequence of SEQ ID NO: 4; and
- (b) a fragment of (a) wherein the fragment comprises amino acids 93-201 of SEQ ID NO: 4 and binds to and stimulates phosphorylation of VEGFR-2 or VEGFR-3.

30. An improvement in a medical device designed to contact a surface of a blood vessel in the course of surgery to inhibit stenosis or restenosis of the blood vessel, said improvement comprising integrating into the device a composition effective to inhibit stenosis or restenosis, said composition comprising a polynucleotide operatively linked to a promoter for expression of a polypeptide encoded by the polynucleotide in cells of blood vessels,

wherein the device is selected from the group consisting of an intravascular stent; an intravascular catheter; a combination of an intravascular stent and catheter; an extravascular collar; and an elastomeric membrane adapted to cover a surface of an intravascular stent or catheter; and

wherein the polynucleotide comprises a nucleotide sequence that encodes a polypeptide that comprises amino acids 93 to 201 of SEQ ID NO: 4 and that binds and stimulates at least one receptor selected from the group consisting of human VEGFR-2 and VEGFR-3.

31. The improvement of claim 29 or 30 wherein the composition comprises a gene therapy vector comprising said polynucleotide, wherein the gene therapy vector is selected from the group consisting of a replication-deficient adenovirus, an adeno-associated virus, an adenovirus, a lipofectin-mediated gene transfer vector, a liposome, and a naked DNA plasmid.

47

32. The improvement of claim 29 or 30, wherein the device is selected from the group consisting of the intravascular stent, the intravascular catheter, and the combination thereof.

33. The improvement of claim 29 or 30, wherein the device comprises the extravascular collar.

34. The improvement of claim 29 or 30, wherein the device comprises the elastomeric membrane adapted to cover a surface of an intravascular stent or catheter.

35. A medical device comprising an endovascular stent having an outer surface for contacting a surface of a blood vessel, and a composition on said outer surface, said composition comprising a polynucleotide operatively linked to a promoter for expression of a polypeptide encoded by the polynucleotide in cells of blood vessels,

wherein the encoded polypeptide comprises an amino acid sequence selected from the group consisting of:

- (a) the amino acid sequence of SEQ ID NO: 4; and
- (b) a fragment of (a) wherein the fragment comprises amino acids 93-201 of SEQ ID NO: 4 and binds to and stimulates phosphorylation of VEGFR-2 or VEGFR-3.

36. A medical device comprising a catheter having an outer surface for contacting a surface of a blood vessel, and a composition on said outer surface, said composition comprising a polynucleotide operatively linked to a promoter for expression of a polypeptide encoded by the polynucleotide in cells of blood vessels,

wherein the encoded polypeptide comprises an amino acid sequence selected from the group consisting of:

- (a) the amino acid sequence of SEQ ID NO: 4; and
- (b) a fragment of (a) wherein the fragment comprises amino acids 93-201 of SEQ ID NO: 4 and binds to and stimulates phosphorylation of VEGFR-2 or VEGFR-3.

37. A medical device comprising a balloon catheter having a void for holding a composition for delivery to the interior of a blood vessel, and a composition contained in the void, the composition comprising a polynucleotide operatively linked to a promoter for expression of a polypeptide encoded by the polynucleotide in cells of blood vessels,

wherein the encoded polypeptide comprises an amino acid sequence selected from the group consisting of:

- (a) the amino acid sequence of SEQ ID NO: 4; and
- (b) a fragment of (a) wherein the fragment comprises amino acids 93-201 of SEQ ID NO: 4 and binds to and stimulates phosphorylation of VEGFR-2 or VEGFR-3.

38. The medical device of any one of claims 35-37 wherein the composition comprises a gene therapy vector comprising

48

said polynucleotide, wherein the gene therapy vector is selected from the group consisting of a replication-deficient adenovirus, an adeno-associated virus, an adenovirus, a lipofectin-mediated gene transfer vector, a liposome, and a naked DNA plasmid.

39. A medical device comprising an extravascular collar comprising a composition for delivery to a blood vessel, the composition comprising a polynucleotide operatively linked to a promoter for expression of a polypeptide encoded by the polynucleotide in cells of the blood vessel,

wherein the encoded polypeptide comprises an amino acid sequence selected from the group consisting of:

- (a) the amino acid sequence of SEQ ID NO: 4; and
- (b) a fragment of (a) wherein the fragment comprises amino acids 93-201 of SEQ ID NO: 4 and binds to and stimulates phosphorylation of VEGFR-2 or VEGFR-3.

40. The device of claim 39 wherein the extravascular collar is coated with, impregnated with or encapsulates the composition.

41. The device of claim 39 comprising a body adapted to provide a seal around the blood vessel and to define a reservoir for holding the composition.

42. The device of claim 39 wherein the composition comprises a gene therapy vector comprising said polynucleotide, wherein the gene therapy vector is selected from the group consisting of a replication-deficient adenovirus, an adeno-associated virus, an adenovirus, a lipofectin-mediated gene transfer vector, a liposome, and a naked DNA plasmid.

43. The device of claim 39 wherein said encoded polypeptide lacks amino acids 1 to 92 of SEQ ID NO: 4 and lacks amino acids 202 to 354 of SEQ ID NO: 4.

44. The device of claim 39, wherein the polynucleotide comprises a nucleotide sequence that encodes the polypeptide comprising the fragment of SEQ ID NO: 4 that comprises amino acids 93-201 of SEQ ID NO: 4 and further encodes a secretory signal peptide, wherein the sequence of the secretory signal peptide is a heterologous sequence, and wherein the polynucleotide sequence encoding the secretory signal peptide is operably linked to the promoter and is connected in-frame with the sequence that encodes the polypeptide.

45. The device or the improvement of any one of claim 29, 35, 36, 37, or 39, wherein the polypeptide comprises the fragment of SEQ ID NO: 4, wherein the fragment comprises amino acids 93-201 of SEQ ID NO: 4.

46. The device or the improvement of any one of claims 29, 35, 36, 37 or 39, wherein the VEGF-D polypeptide comprises amino acids 1-354 of SEQ ID NO: 4.

* * * * *