

7-1987

# Reliability and Throughput Analysis of a Concatenated Coding System

Robert H. DENG

*Singapore Management University*, robertdeng@smu.edu.sg

Daniel J. COSTELLO

*University of Notre Dame*

**DOI:** <https://doi.org/10.1109/TCOM.1987.1096850>

Follow this and additional works at: [https://ink.library.smu.edu.sg/sis\\_research](https://ink.library.smu.edu.sg/sis_research)



Part of the [Information Security Commons](#)

---

## Citation

DENG, Robert H. and COSTELLO, Daniel J.. Reliability and Throughput Analysis of a Concatenated Coding System. (1987). *IEEE Transactions on Communications*. 35, (7), 698-705. Research Collection School Of Information Systems.

**Available at:** [https://ink.library.smu.edu.sg/sis\\_research/144](https://ink.library.smu.edu.sg/sis_research/144)

This Journal Article is brought to you for free and open access by the School of Information Systems at Institutional Knowledge at Singapore Management University. It has been accepted for inclusion in Research Collection School Of Information Systems by an authorized administrator of Institutional Knowledge at Singapore Management University. For more information, please email [libIR@smu.edu.sg](mailto:libIR@smu.edu.sg).

# Reliability and Throughput Analysis of a Concatenated Coding Scheme

ROBERT H. DENG, MEMBER, IEEE, AND DANIEL J. COSTELLO, JR., FELLOW, IEEE

**Abstract**—In this paper, the performance of a concatenated coding scheme for error control in ARQ systems is analyzed for both random-error and burst-error channels. In particular, the probability of undetected error and the system throughput are calculated. In this scheme, the inner code is used for both error correction and error detection, and the outer code is used for error detection only. Interleaving/deinterleaving of the outer code is assumed. A retransmission is requested if either the inner code or the outer code detects the presence of errors. Various coding examples are considered. The results show that concatenated coding can provide extremely high system reliability (i.e., low probability of undetected error) and high system throughput.

## I. INTRODUCTION

IN a companion paper [1], the probability of undetected error in a specific concatenated coding scheme on a memoryless binary symmetric channel (MBSC) was calculated. Two linear block codes, denoted by  $C_f$  and  $C_b$ , are used in the concatenated code. The inner code  $C_f$ , called the *frame code*, is an  $(n, k)$  systematic binary block code with minimum distance  $d_f$ . The frame code is designed to correct  $t$  or fewer errors and to simultaneously detect  $\lambda$  ( $\lambda > t$ ) or fewer errors where  $t + \lambda + 1 \leq d_f$  [2]. The outer code is an  $(n_b, k_b)$  binary block code with

$$n_b = mk \quad (1)$$

where  $m$ , a positive integer, is the number of frames. The outer code is designed for error detection only.

No interleaving/deinterleaving within the concatenated coding scheme was assumed in [1]. In this paper, we modify the coding scheme of [1] by assuming interleaving/deinterleaving within an outer code word. In addition, we extend the analysis to include burst-error channels.

The encoding of the concatenated code is achieved in two stages (see Fig. 1). A message of  $k_b$  bits is first encoded into a code word of  $n_b$  bits in the outer code  $C_b$ . Then this code word is interleaved to depth  $m$ . After interleaving, the  $n_b$ -bit block is divided into  $m$   $k$ -bit words for encoding by the frame code  $C_f$ . Each  $n$ -bit code word is called a frame. The two-dimensional block format is depicted in Fig. 2.

Decoding consists of error correction and error detection on each frame and error detection on the  $m$  decoded  $k$ -bit segments. When a frame is received, it is first decoded based on the frame code  $C_f$ . The  $n-k$  parity bits are then removed from the decoded frame. If there are  $t$  or fewer transmission errors in a received frame, the errors will be corrected, and the decoded segment is error free. If there are more than  $t$  errors in the received frame, the errors will be either detected or

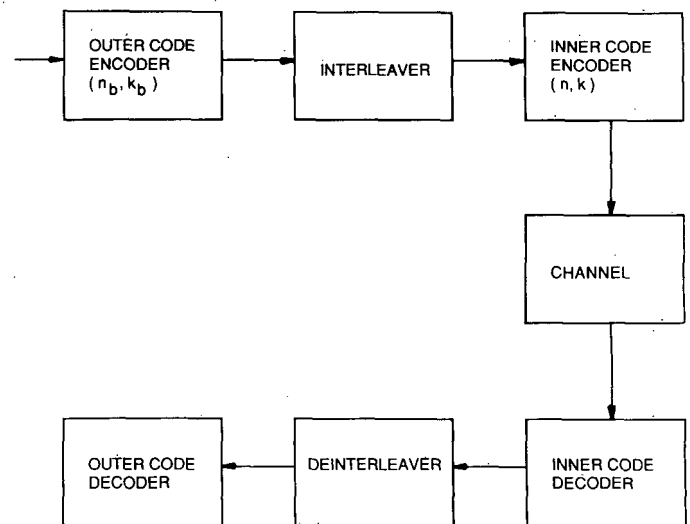

Fig. 1. A concatenated coding system.

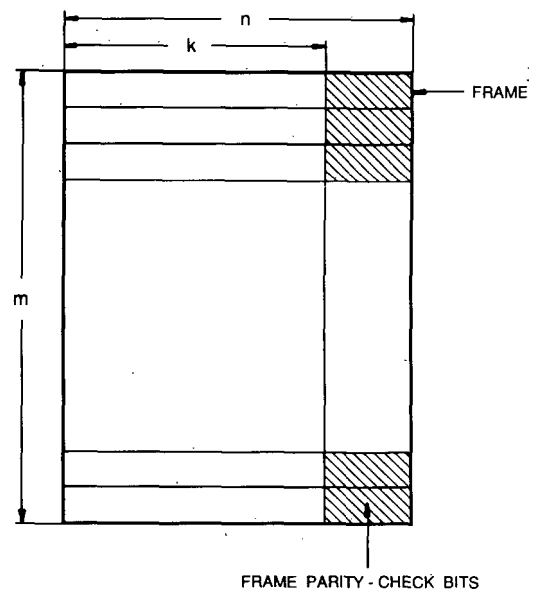

Fig. 2. Block format of a concatenated code word.

undetected. If the errors are detected, the decoder stops decoding immediately and requests a retransmission of the entire block. On the other hand, if the errors in a frame are undetected, the decoded segments are stored in a buffer, and the decoder begins to decode the next frame. After the  $m$  frames of a block have been decoded, the  $m$   $k$ -bit decoded segments are then deinterleaved. Error detection is then performed on these deinterleaved segments based on the outer code  $C_b$ . If no errors are detected, the  $m$  decoded segments are assumed to be error free and are accepted by the receiver. If

Paper approved by the Editor for Digital Communications of the IEEE Communications Society. Manuscript received December 4, 1985; revised January 15, 1987. This research was supported in part by NASA under Grant NAG5-557 and in part by the National Science Foundation under Grant ECS84-14608. This paper was presented at the Allerton Conference on Communication, Control, and Computing, Monticello, IL, October 1984.

The authors are with the Department of Electrical and Computer Engineering, University of Notre Dame, Notre Dame, IN 46556.

IEEE Log Number 8715027.

the presence of errors is detected, the  $m$  decoded segments are discarded, and the receiver requests a retransmission of the entire block.

The error control scheme described above is actually a combination of forward error correction (FEC) and automatic repeat request (ARQ). In this paper, we analyze the performance of this error control scheme. Specifically, the system reliability and throughput are calculated. The system reliability is measured in terms of the probability of undetected error after decoding.

First, by assuming the inner channel to be an MBSC with a bit error rate (BER)  $\epsilon$ , we look at the outer channel created by the combination of the interleaver, the frame code, and the inner channel. Then we develop precise expressions for both the probability of undetected error and the system throughput. Various coding examples are considered, and one case studied in [1] is included for comparison. Our results indicate that concatenated coding can provide high throughputs and extremely low undetected error probabilities at moderate values of  $\epsilon$ , and for the example considered in [1], the probability of undetected error is slightly lower with interleaving than without interleaving. In addition, interleaving randomizes the errors made by the inner decoder and simplifies the performance analysis compared to the analysis without interleaving, which requires a detailed knowledge of the algebraic structure of both the inner code and the outer code. This allows us to easily compare the performance of several different coding examples.

Finally, the analysis is extended to a Gilbert-type burst-error channel [3]–[5]. The burst-error channel contains two states. Each state represents an MBSC with BER  $\epsilon_j$ ,  $j = 1, 2$ , and  $\epsilon_2 \gg \epsilon_1$ . The probabilities of undetected error on burst-error channels degrade slightly compared to those on MBSC's with the same average BER, while the system throughputs remain almost the same for moderate values of average BER. Therefore, the proposed coding scheme is quite robust for a variety of channels.

## II. SYSTEM PERFORMANCE ON AN MBSC

### A. The Outer Channel Model

Let  $P_c^{(f)}(\epsilon)$  denote the probability of correct decoding for the inner frame code. Suppose that a bounded-distance decoding algorithm is employed. Bounded-distance decoding corrects all received  $n$ -bit frames with  $t$  or fewer errors. When an  $n$ -bit frame with more than  $t$  errors is detected, no attempt is made to correct the errors. Since there are  $\binom{n}{i}$  distinct ways in which  $i$  errors may occur among  $n$  bits,

$$P_c^{(f)}(\epsilon) = \sum_{j=0}^t \binom{n}{j} \epsilon^j (1-\epsilon)^{n-j} \quad (2)$$

for bounded-distance decoding.

For a code word  $\mathbf{v}$  in the frame code  $C_f$ , let  $w(\mathbf{v})$  denote the Hamming weight of  $\mathbf{v}$ . If a decoded frame contains an undetectable error pattern, this error pattern must be a nonzero code word in  $C_f$ . Let  $\mathbf{e}_o$  be an undetectable error pattern after decoding. The probability  $P_f(w, \epsilon)$  that a decoded frame contains a specific nonzero error pattern  $\mathbf{e}_o$  of weight  $w$  after decoding is given by [1], [6]–[8]:

$$P_f(w, \epsilon) = \sum_{i=0}^t \sum_{j=0}^{\min(t-i, n-w)} \binom{w}{i} \binom{n-w}{j} \epsilon^{w-i+j} (1-\epsilon)^{n-w+i-j} \quad (3)$$

where  $w = w(\mathbf{e}_o)$  and  $\epsilon$  is the BER of the inner channel. If  $\epsilon \ll (1/n)$ , then

$$P_f(w, \epsilon) \approx \binom{w}{t} \epsilon^{w-t} (1-\epsilon)^{n-w+t}. \quad (4)$$

Let  $P_{ud}^{(f)}(\epsilon)$  denote the probability of undetected error for the frame code. Let  $\{A_w^{(f)}, d_f \leq w \leq n\}$  be the weight distribution of  $C_f$ . It follows from (3) and (4) that

$$P_{ud}^{(f)}(\epsilon) = \sum_{w=d_f}^n A_w^{(f)} P_f(w, \epsilon) \quad (5)$$

and

$$P_{ud}^{(f)}(\epsilon) \approx A_{d_f}^{(f)} P_f(d_f, \epsilon) \approx A_{d_f}^{(f)} \binom{d_f}{t} \epsilon^{d_f-t} (1-\epsilon)^{n-d_f+t}, \quad \text{for } \epsilon \ll \frac{1}{n}. \quad (6)$$

Now consider any one of the  $m$  frames. If the decoded frame contains undetected errors, the BER  $\epsilon_a$  after decoding is given by

$$\epsilon_a = \frac{1}{n} \sum_{w=d_f}^n w A_w^{(f)} P_f(w, \epsilon). \quad (7)$$

For  $\epsilon \ll (1/n)$ ,

$$\epsilon_a \approx \frac{1}{n} d_f A_{d_f}^{(f)} P_f(d_f, \epsilon) \quad (8)$$

is a good approximation to  $\epsilon_a$ . Let  $E$  be defined as the event that a frame contains undetected errors. Let  $\epsilon_{a/E}$  denote the BER embedded in a decoded frame conditioned on the occurrence of event  $E$ . It follows from (7) that

$$\epsilon_{a/E} = \epsilon_a / \Pr\{E\} = \epsilon_a / P_{ud}^{(f)}(\epsilon). \quad (9)$$

For  $\epsilon \ll (1/n)$ , substituting (6) and (8) into (9) yields

$$\epsilon_{a/E} \approx \frac{(1/n) d_f A_{d_f}^{(f)} P_f(d_f, \epsilon)}{A_{d_f}^{(f)} P_f(d_f, \epsilon)} = \frac{d_f}{n}. \quad (10)$$

Now define  $S$  to be a random variable such that when  $h$  of the  $m$  frames contain undetected errors, and the remaining  $m-h$  frames are decoded correctly,  $S = h$ ,  $h = 0, 1, 2, \dots, m$ . It follows from (2) and (5) that

$$\Pr\{S = h\} = \binom{m}{h} [P_{ud}^{(f)}(\epsilon)]^h [P_c^{(f)}(\epsilon)]^{m-h}. \quad (11)$$

Note that (11) is not a binomial distribution because  $P_{ud}^{(f)}(\epsilon) + P_c^{(f)}(\epsilon) < 1$ , i.e., some received frames with more than  $t$  errors are detected by the frame code.

After the deinterleaving of the  $m$  decoded segments (with the  $n-k$  parity bits removed from each frame), the BER embedded in the  $n_b$ -bit block, conditioned on  $S = h$ , is given by

$$\epsilon_o(h) = \epsilon_{a/E} \cdot \frac{h}{m}, \quad h = 0, 1, 2, \dots, m. \quad (12)$$

We call the channel specified by (11) and (12) the outer channel, and it is depicted in Fig. 3.<sup>1</sup> Note that  $\epsilon_o(0) = 0$ . This outer channel can be viewed as a block interference (BI) channel, as described in [9].  $\Delta_h$ ,  $h = 0, 1, 2, \dots, m$ , is called the  $h$ th component channel of the BI channel. Each block of  $n_b$  bits ( $n_b$  is the length of the outer code) is transmitted over one of the  $m+1$  component channels. The random variable  $S$

<sup>1</sup> We assume that the frame code has a large number of minimum-weight code words. This implies that after deinterleaving each position in the outer code contains an error with the same probability, so that each component channel can be viewed as a BSC.

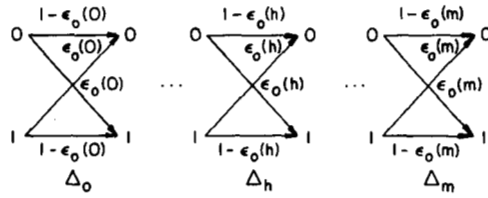

Fig. 3. The outer channel resulting from decoding the inner code on an MBSC.

determines which component channel is used to transmit a given  $n_b$ -bit block.

### B. The Probability of Undetected Error and the System Throughput

Let  $\{A_i^{(b)}, d_b \leq i \leq n_b\}$  be the weight distribution of the outer code where  $d_b$  is the minimum distance of  $C_b$ . Let  $P_{ud}^{(b)}(\epsilon)$  be the probability of undetected error for the outer code  $C_b$ . If the  $n_b$ -bit block is transmitted over the  $h$ th component channel  $\Delta_h$  of the outer channel, it follows from (12) that

$$P_{ud}^{(b)}(\epsilon_o(h)) = \sum_{i=d_b}^{n_b} A_i^{(b)}(\epsilon_o(h))^i (1 - \epsilon_o(h))^{n_b-i}. \quad (13)$$

Let  $P_{ud}(\epsilon)$  be the average probability of undetected error of the concatenated code. From (11) and (13), we obtain

$$\begin{aligned} P_{ud}(\epsilon) &= \sum_{h=0}^m P_r\{S=h\} P_{ud}^{(b)}(\epsilon_o(h)) \\ &= \sum_{h=1}^m \left\{ \binom{m}{h} [P_{ud}^{(f)}(\epsilon)]^h [P_c^{(f)}(\epsilon)]^{m-h} \right. \\ &\quad \left. \cdot \sum_{i=d_b}^{n_b} A_i^{(b)}(\epsilon_o(h))^i (1 - \epsilon_o(h))^{n_b-i} \right\} \end{aligned} \quad (14)$$

where  $P_c^{(f)}(\epsilon)$  and  $P_{ud}^{(f)}(\epsilon)$  are given by (2) and (5), respectively.

The system throughput is defined as the ratio of the average number of information bits successfully accepted by the receiver per unit time to the total number of bits that can be transmitted per unit time [2]. It is determined by the retransmission strategy, which may be one of the three basic types: stop and wait, go back  $N$ , or selective repeat. All three basic ARQ schemes achieve the same reliability; however, they have different throughputs. Suppose that *selective-repeat* ARQ is used as the retransmission strategy. The specific manner in which the receiver signals to the transmitter for a retransmission will not be considered. It will be assumed, however, that this backward signal is error free and that repeat retransmissions of a block are possible. Then the throughput of the concatenated coding system is [2]

$$\eta = \frac{k}{n} \cdot \frac{k_b}{n_b} \cdot (P_{ud}(\epsilon) + P_c(\epsilon)) \quad (15)$$

where  $P_c(\epsilon)$  is the probability of accepting a correct block. Note that a transmitted block will be received correctly if and only if all  $m$  frames are decoded correctly. Therefore,

$$P_c(\epsilon) = [P_c^{(f)}(\epsilon)]^m = \left[ \sum_{j=0}^t \binom{n}{j} \epsilon^j (1 - \epsilon)^{n-j} \right]^m. \quad (16)$$

For the usual situation where  $P_{ud}(\epsilon) \ll P_c(\epsilon)$ , it follows from

(15) and (16) that

$$\eta \approx \frac{k}{n} \cdot \frac{k_b}{n_b} \cdot \left[ \sum_{j=0}^t \binom{n}{j} \epsilon^j (1 - \epsilon)^{n-j} \right]^m. \quad (17)$$

It can easily be seen that  $\eta$  increases monotonically as  $t$  increases; but for small  $\epsilon$ ,  $\eta$  is only a weakly increasing function of  $t$ .

In order to find the relationship between  $t$  and  $P_{ud}(\epsilon)$ , we see from (14) that

$$\begin{aligned} P_{ud}(\epsilon) &\approx m \cdot P_{ud}^{(f)}(\epsilon) \cdot [P_c^{(f)}(\epsilon)]^{m-1} \\ &\quad \cdot \left\{ \sum_{i=d_b}^{n_b} A_i^{(b)}(\epsilon_o(1))^i (1 - \epsilon_o(1))^{n_b-i} \right\}, \\ &\quad \text{for } \epsilon \ll \frac{1}{n}. \end{aligned} \quad (18)$$

Using (6), (10), and (12),  $P_{ud}(\epsilon)$  can be further approximated as

$$\begin{aligned} P_{ud}(\epsilon) &= K \cdot \left( \frac{d_f}{t} \right) \epsilon^{d_f-t} (1 - \epsilon)^{n-d_f+t} \\ &\quad \cdot [P_c^{(f)}(\epsilon)]^{m-1}, \quad \text{for } \epsilon \ll \frac{1}{n} \end{aligned} \quad (19)$$

where

$$K \triangleq m \cdot A_{d_b}^{(f)} \cdot \left\{ \sum_{i=d_b}^{n_b} A_i^{(b)} \left( \frac{d_f}{mn} \right)^i \left( 1 - \frac{d_f}{mn} \right)^{n_b-i} \right\}$$

is a constant that is independent of  $t$ . Let  $Q(t)$  denote the right-hand side of (19). Then

$$\frac{Q(t+1)}{Q(t)} \approx \frac{(d_f-t)}{(t+1)} \cdot \frac{1}{\epsilon} \gg n, \quad \text{for } \epsilon \ll \frac{1}{n}. \quad (20)$$

That is, for  $\epsilon \ll (1/n)$ , when  $t$  increases by 1,  $P_{ud}(\epsilon)$ , the probability of undetected error, will increase by approximately  $\epsilon^{-1}$ . Thus,  $P_{ud}(\epsilon)$  is a strongly increasing function of  $t$ . For this reason, a large value of  $t$  is not desirable in such a system.

### C. Coding Examples

In this subsection, we present some concatenated code examples whose purpose is to give a feeling for actual system performance. Recall that the concatenated coding scheme described above is used in ARQ systems and that the major advantage of ARQ is that it requires simple decoding while achieving high system reliability and throughput. Therefore, only codes that require simple decoding are chosen as examples.

*Example 1:* In this example, the frame code is an  $(n, n-1)$  single-parity-check code. The frame code has a minimum distance  $d_f = 2$  and is used for error detection only. The frame code can detect all odd-weight error patterns. The weight distribution of the frame code can be calculated from

$$A_{2i}^{(f)} = \binom{n-1}{2i} + \binom{n-1}{2i-1}, \quad i=1, 2, 3, \dots, \frac{n}{2}, \quad (21a)$$

$$A_j^{(f)} = 0 \quad \text{for all odd } j \quad (21b)$$

where  $\binom{n}{k} = 0$  for  $k < 0$  and  $k > n$ . The outer code is a distance-4 shortened Hamming code with generator poly-

mial

$$g(x) = (x+1)(x^{15} + x^{14} + x^{13} + x^{12} + x^4 + x^3 + x^2 + x + 1) \\ = x^{16} + x^{12} + x^5 + 1 \quad (22)$$

where  $x^{15} + x^{14} + x^{13} + x^{12} + x^4 + x^3 + x^2 + x + 1$  is a primitive polynomial of degree 15. This code is the X.25 standard for packet-switched data networks [10]. The natural length of this code is  $2^{15} - 1 = 32767$ . In this example, a shortened code of maximum length 3584 bits is considered. This code is used for error detection only. Two cases are considered: 1) The number of information bytes IB = 7 ( $n = 57$ ) and the number of frames in a block  $m = 64$  ( $n_b = km = 56 \times 64 = 3584$ ); and 2) IB = 4 ( $n = 33$ ),  $m = 24$  ( $n_b = 768$ ).

Because the outer code can detect three or fewer errors, if only one frame contains a weight-3 or less undetected error pattern, then this error pattern can always be detected by the outer code. Thus, (14) can be modified as follows:

$$P_{ud}(\epsilon) = \binom{m}{1} \bar{P}_{ud}^{(f)}(\epsilon) [P_c^{(f)}(\epsilon)]^{m-1} \\ \cdot \sum_{i=d_b}^{n_b} A_i^{(b)}(\bar{\epsilon}_o(1))^i (1 - \bar{\epsilon}_o(1))^{n_b-i} \\ + \sum_{h=2}^m \left\{ \binom{m}{h} [P_{ud}^{(f)}(\epsilon)]^h [P_c^{(f)}(\epsilon)]^{m-h} \right. \\ \left. \cdot \sum_{i=d_b}^{n_b} A_i^{(b)}(\epsilon_o(h))^i (1 - \epsilon_o(h))^{n_b-i} \right\} \quad (23)$$

where

$$\bar{P}_{ud}^{(f)}(\epsilon) = \sum_{w=d_f+2}^n A_w^{(f)} P_f(w, \epsilon) \quad (24a)$$

and

$$\bar{\epsilon}_o(1) = \frac{(1/n) \sum_{w=d_f+2}^n w A_w^{(f)} P_f(w, \epsilon)}{\bar{P}_{ud}^{(f)}(\epsilon)} \cdot \frac{1}{m} \quad (24b)$$

Results for the probability of undetected error  $P_{ud}(\epsilon)$ , based on (23) and the system throughput  $\eta$ , are plotted in Fig. 4 for  $m = 64$ , IB = 7 and for  $m = 24$ , IB = 4, respectively, where we have used the method in [11] to obtain

$$P_{ud}^{(b)}(\epsilon_o(h)) = \sum_{i=d_b}^{n_b} A_i^{(b)}(\epsilon_o(h))^i (1 - \epsilon_o(h))^{n_b-i}.$$

*Example 2:* This concatenated code example has been proposed for a NASA telecommand system and was also considered in [1]. The frame code  $C_f$  is a distance-4 Hamming code with generator polynomial

$$g(x) = (x+1)(x^6 + x + 1) = x^7 + x^6 + x^2 + 1 \quad (25)$$

where  $x^6 + x + 1$  is a primitive polynomial of degree 6. The natural length of this code is 63. This code is used for single-error correction ( $t = 1$ ) and is also used to detect all error patterns of weight 2 and some higher odd-weight error patterns. The same outer code as in Example 1 is employed.

To obtain a precise result for  $P_{ud}(\epsilon)$ , a computer program was written to help determine the reliability of the proposed concatenated coding scheme. We found that if only one frame contains a weight-4 undetected error pattern, then this error

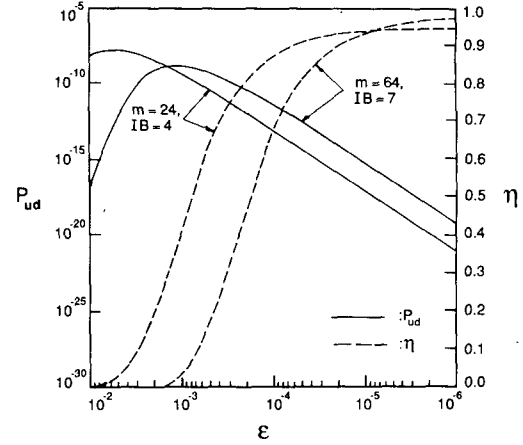

Fig. 4. Performance of the concatenated code of Example 1.

pattern can always be detected by the outer code. Hence, (23) is used to compute the probability of undetected error. Fig. 5 shows the probability of undetected error  $P_{ud}(\epsilon)$  and the system throughput  $\eta$  for this example. Comparing the results here to those obtained in [1], we see that interleaving slightly improves the system reliability. For example, for  $\epsilon = 10^{-5}$ ,  $P_{ud}(\epsilon) = 6.7 \times 10^{-22}$  with interleaving, while  $8.05 \times 10^{-22} \leq P_{ud}(\epsilon) \leq 8.78 \times 10^{-19}$  without interleaving [1].

The example described above can be altered by allowing the frame code to do error detection only (i.e.,  $t = 0$ ). In this case,  $P_{ud}(\epsilon)$  and  $\eta$  are also shown in Fig. 5.

*Example 3:* The same frame code and outer code as in Example 2 are employed. However, the inner channel is assumed to be an AWGN channel with BPSK modulation, and the frame code is decoded by using the Viterbi decoding algorithm with repeat request and infinite demodulator output quantization [12], [13]. Let  $u$ , a positive real number, be the retransmission metric threshold of the algorithm [13]. Let  $P_{ud}^{(f)}$ ,  $P_d^{(f)}$ , and  $\epsilon_a$  denote the probability of undetected error, the probability of detected error, and the BER after decoding, respectively, for the frame code. Then [13]

$$P_{ud}^{(f)} \leq kQ \left( \sqrt{\frac{2E_N}{N_0}} d_f + u \sqrt{\frac{2E_N}{N_0}} \right) \\ \cdot \exp \left( \frac{E_N}{N_0} d_f \right) T(X) \Big|_{X = \exp \left( -\frac{E_N}{N_0} \right)} \quad (26)$$

$$P_d^{(f)} \leq kQ \left( \sqrt{\frac{2E_N}{N_0}} d_f - u \sqrt{\frac{2E_N}{N_0}} \right) \\ \cdot \exp \left( \frac{E_N}{N_0} d_f \right) T(X) \Big|_{X = \exp \left( -\frac{E_N}{N_0} \right)} \quad (27)$$

$$\epsilon_a \leq Q \left( \sqrt{\frac{2E_N}{N_0}} d_f + u \sqrt{\frac{2E_N}{N_0}} \right) \\ \cdot \exp \left( \frac{E_N}{N_0} d_f \right) \frac{\partial T(X, Y)}{\partial Y} \Big|_{X = \exp \left( -\frac{E_N}{N_0} \right), Y=1} \quad (28)$$

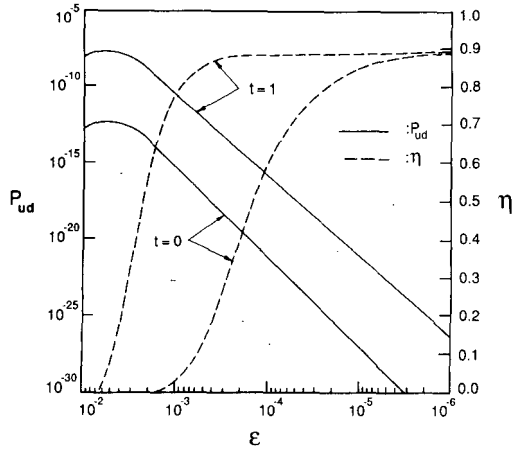

Fig. 5. Performance of the concatenated code of Example 2 with  $m = 64$ ,  $IB = 7$ .

where

$$Q(X) = \frac{1}{\sqrt{2\pi}} \int_x^{\infty} e^{-z^2/2} dz \quad (29)$$

$$T(X) = \sum_{i=d_f}^n A_i^{(f)} X^i \quad (30)$$

$$\frac{\partial T(X, Y)}{\partial Y} \Big|_{Y=1} = \sum_{i=d_f}^n B_i^{(f)} X^i. \quad (31)$$

$E_N/N_0$  is the channel symbol signal energy-to-noise power density ratio, and  $B_i^{(f)}$  is the total number of nonzero information bits in all code words of weight  $i$ . From (26) and (27), we see that the probability of correct decoding for the frame code is

$$\begin{aligned} P_c^{(f)} &= 1 - P_{ud}^{(f)} - P_d^{(f)} \\ &\approx 1 - P_d^{(f)}, \quad \text{for } P_{ud}^{(f)} \ll P_d^{(f)}. \end{aligned} \quad (32)$$

The probability of undetected error of the concatenated code,  $P_{ud}$ , and the system throughput  $\eta$  can be computed by using (26)–(32) in (23) and (15). In (23),  $\epsilon_o(h)$ ,  $h = 2, 3, \dots, m$ , is given by (9) and (12), and

$$\begin{aligned} \bar{P}_{ud}^{(f)} &\leq kQ \left( \sqrt{\frac{2E_N}{N_0} (d_f+2)} + u \sqrt{\frac{2E_N}{N_0}} \right) \\ &\cdot \exp \left( \frac{E_N}{N_0} (d_f+2) \right) \\ &\cdot \left( \sum_{i=d_f+2}^n A_i^{(f)} X^i \right) \Big|_{X = \exp \left( -\frac{E_N}{N_0} \right)} \end{aligned} \quad (33)$$

$$\bar{\epsilon}_o(1) = \frac{Q \left( \sqrt{\frac{2E_N}{N_0} (d_f+2)} + u \sqrt{\frac{2E_N}{N_0}} \right) \exp \left( \frac{E_N}{N_0} (d_f+2) \right) \left( \sum_{i=d_f+2}^n B_i^{(f)} X^i \right) \Big|_{X = \exp \left( -\frac{E_N}{N_0} \right)}}{\bar{P}_{ud}^{(f)}}. \quad (34)$$

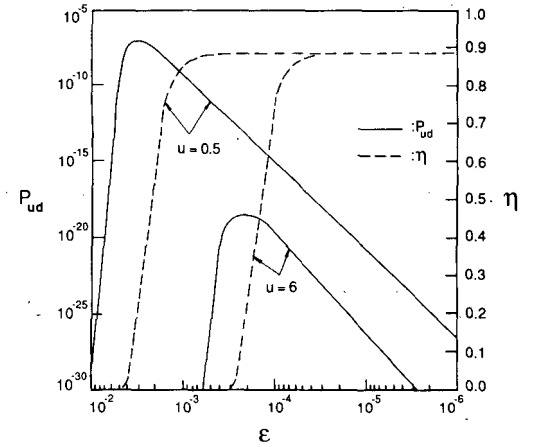

Fig. 6. Performance of the concatenated code of Example 3 with  $m = 64$ ,  $IB = 7$ .

Both  $P_{ud}$  and  $\eta$  are shown in Fig. 6 for  $u = 0.5$  and 6 where  $E_N/N_0$  and  $\epsilon$  are related by the equation

$$\epsilon = Q \left( \sqrt{\frac{2E_N}{N_0}} \right). \quad (35)$$

The influence of the value of  $u$  on the system performance is obvious. For larger values of  $u$ , from (26), (27), and (32), the probabilities  $P_{ud}^{(f)}$  and  $P_d^{(f)}$  become smaller, and consequently, the probability of undetected error and the system throughput are lower.

From Figs. 4–6, we observe that the performance of a particular scheme depends strongly upon the channel noise conditions. Therefore, we cannot say that a particular one of the above schemes is “best.” However, we can draw several conclusions, which will be discussed below.

Fig. 4 shows that lower inner code rates provide higher system reliabilities and system throughputs for relatively large channel BER. As the channel BER becomes small, higher inner code rates outperform lower inner code rates in terms of throughput.

Fig. 5 shows the tradeoffs between the probability of undetected error and the system throughput obtained by varying the number of correctable errors  $t$  in the frame code. Smaller values of  $t$  always result in a lower probability of undetected error and, therefore, a higher system reliability. But as the channel BER gets higher, the system throughput degrades rapidly for small  $t$ . The system throughput is less affected by  $t$  if the channel BER is small.

Fig. 6 shows the advantages of a Viterbi decoded (soft decision) frame code over an algebraically decoded (hard decision) frame code. The Viterbi decoding algorithm makes the system much more flexible in trading between system reliability and throughput by simply changing the value of  $u$ . Varying  $u$  can be viewed as a generalized method of “varying  $t$ ” for algebraic decoding of the frame code. We conclude that, at moderately lower BER’s, the concatenated coding scheme is capable of achieving high system throughputs and extremely low undetected error probabilities.

### III. SYSTEM PERFORMANCE ON A BURST-ERROR CHANNEL

Channels with memory often occur in practice. Errors on these channels tend to occur in bursts, and hence they are

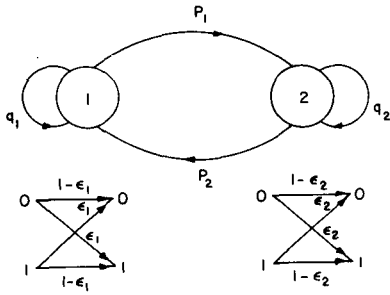

Fig. 7. The burst-error inner channel.

called *burst-error channels*. In this section, we extend the performance analysis of the concatenated coding scheme to burst-error channels.

#### A. The Inner Channel Model

The generalized Gilbert-type channel [3]–[5], as shown in Fig. 7, is used as our inner channel model. There are two states in the model. Each state represents a BSC. State 1 is the “quiet” state where the BER is  $\epsilon_1$ . State 2 is the “noisy” state, where the BER is  $\epsilon_2$ , and  $\epsilon_2 \gg \epsilon_1$ . The transition probabilities between states are  $p_1 = \Pr\{1 \rightarrow 2\}$  and  $p_2 = \Pr\{2 \rightarrow 1\}$  (see Fig. 7). The probabilities of remaining in states 1 and 2 are  $q_1 = 1 - p_1$  and  $q_2 = 1 - p_2$ , respectively. To simplify the model’s treatment, we assume that one transition time in the model corresponds to the transmission of one frame of length  $n$  bits, i.e., the error bursts last for a multiple of the transmission time of a frame. This is a reasonable assumption for channels where error burst lengths are usually long compared to the transmission time of one frame.<sup>2</sup> The average burst length is then [3]

$$\bar{L} = \frac{1}{p_2} \text{ frames} \quad (36)$$

or

$$\bar{l} = \bar{L}n = \frac{1}{p_2} n \text{ bits} \quad (37)$$

the average BER is

$$\bar{\epsilon} = \frac{1}{p_1 + p_2} (p_2 \epsilon_1 + p_1 \epsilon_2) \quad (38)$$

and the steady-state probability of being in the noisy state is

$$P_n = \frac{\bar{\epsilon} - \epsilon_1}{\epsilon_2 - \epsilon_1}. \quad (39)$$

Four parameters govern the model. They can be chosen to be  $\bar{L}$ ,  $\bar{\epsilon}$ ,  $P_n$ , and the high-to-low BER ratio  $\epsilon_2/\epsilon_1$ .

#### B. The Outer Channel Model

Let  $P_c^{(j)}(\epsilon_j)$ ,  $P_{ud}^{(j)}(\epsilon_j)$ ,  $\epsilon_{aj}$ , and  $\epsilon_{aj/E}$ ,  $j = 1, 2$ , denote the probability of correct decoding for the frame code, the probability of undetected error for the frame code, the BER in a decoded frame, and the BER embedded in the decoded frame conditioned on the decoded frame containing undetected errors, respectively, when the frame is transmitted in state  $j$ . (In the following, we will always use the subscript  $j$ ,  $j = 1, 2$ , to denote that a frame is transmitted in state  $j$ .) Then  $P_c^{(j)}(\epsilon_j)$ ,  $P_{ud}^{(j)}(\epsilon_j)$ ,  $\epsilon_{aj}$ , and  $\epsilon_{aj/E}$  are given by (2), (5), (7), and (9), respectively, with  $\epsilon$  replaced by  $\epsilon_j$ ,  $j = 1, 2$ .

<sup>2</sup> If the frame is not assumed to be synchronized with the error bursts, the number of frames affected by the burst will increase by one and the system performance will degrade slightly.

Now define  $E_{l,h}$ ,  $0 \leq l \leq h \leq m$ , to be an event such that  $h$  of the  $m$  decoded frames contain undetected errors (the other  $m - h$  decoded frames are error free) and  $l$  of the  $h$  frames containing undetected errors are transmitted in state 2 of the inner channel. Let  $\Pr\{E_{l,h}\}$  be the probability that event  $E_{l,h}$  occurs. Then, after the deinterleaving of the  $m$  segments (with the  $n - k$  parity bits removed from each decoded frame), the BER embedded in the  $n_b$ -bit block, conditioned on the occurrence of event  $E_{l,h}$ , is given by

$$\epsilon_o(E_{l,h}) = [l \cdot \epsilon_{a2/E} + (h-l)\epsilon_{a1/E}] / m, \quad 0 \leq l \leq h \leq m. \quad (40)$$

We call the channel specified by (40) and the probability distribution  $\Pr\{E_{l,h}\}$  the outer channel (see Fig. 8).

#### C. The Probability of Undetected Error and the System Throughput

If the  $n_b$ -bit block is transmitted over the component channel  $\Delta_{l,h}$  of the outer channel, the probability of undetected error of the outer code is

$$P_{ud}^{(b)}(\epsilon_o(E_{l,h})) = \sum_{i=d_b}^{n_b} A_i^{(b)}(\epsilon_o(E_{l,h}))^i (1 - \epsilon_o(E_{l,h}))^{n_b - i}. \quad (41)$$

Based on the above outer channel model, the average probability of undetected error of the concatenated code can be expressed as

$$P_{ud} = \sum_{h=0}^m \sum_{l=0}^h \Pr\{E_{l,h}\} P_{ud}^{(b)}(\epsilon_o(E_{l,h})). \quad (42)$$

For large  $m$ , the computation of (42) is very complex and time-consuming. To reduce the computational work to a manageable load, we seek an approximation to (42). Define

$$\epsilon_{\max} = \max[\epsilon_{a1/E}, \epsilon_{a2/E}]. \quad (43)$$

It follows from (40) that

$$\epsilon_o(E_{l,h}) \leq h \cdot \epsilon_{\max} / m \triangleq \epsilon_o(h), \quad (44)$$

and equality holds when  $\epsilon_1$  and  $\epsilon_2$  are equal, i.e., when the inner channel is an MBSC. Assuming that  $P_{ud}^{(b)}(\epsilon)$  is an increasing function of  $\epsilon$ ,  $0 \leq \epsilon \leq (1/2)$ , we obtain from (42) and (44)

$$\begin{aligned} P_{ud} &\leq \sum_{h=0}^m \sum_{l=0}^h \Pr\{E_{l,h}\} P_{ud}^{(b)}(\epsilon_o(h)) \\ &= \sum_{h=0}^m P_{ud}^{(b)}(\epsilon_o(h)) \sum_{l=0}^h \Pr\{E_{l,h}\} \\ &= \sum_{h=0}^m P_{ud}^{(b)}(\epsilon_o(h)) \beta(h) \end{aligned} \quad (45)$$

where

$$\beta(h) \triangleq \sum_{l=0}^h \Pr\{E_{l,h}\}, \quad 0 \leq h \leq m \quad (46)$$

is the probability that  $h$  of the  $m$  decoded frames contain undetected errors (and the remaining  $m - h$  decoded frames are error free).

$\beta(h)$  can be readily computed by a recursive method. To find  $\beta(h)$ , we model the decoded frame status as a Markov chain. In state  $j$ ,  $j = 1, 2$ , the decoded frame contains an undetected error with probability  $P_{ud}^{(j)}(\epsilon_j)$  and is error free with

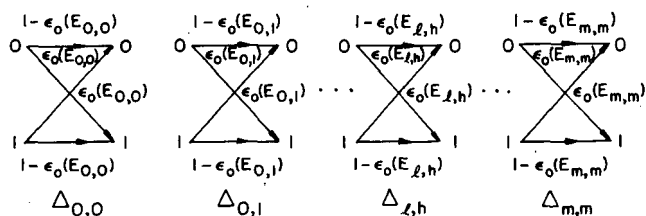

Fig. 8. The outer channel resulting from decoding the inner code on a burst-error channel.

probability  $P_c^{(f)}(\epsilon_j)$ . Define  $G(h, m) = \Pr\{h \text{ of the } m \text{ decoded frames contain undetected errors and/or the inner channel starts in state 1}\}$  and  $B(h, m) = \Pr\{h \text{ of the } m \text{ decoded frames contain undetected errors/the inner channel starts in state 2}\}$ . By applying a similar argument as in [5], we obtain

$$\beta(h) = \frac{p_2}{p_1 + p_2} G(h, m) + \frac{p_1}{p_1 + p_2} B(h, m), \quad 0 \leq h \leq m. \quad (47a)$$

$G(h, m)$  and  $\beta(h, m)$  can be found recursively from

$$\begin{aligned} G(h, m) &= G(h, m-1)q_1P_c^{(f)}(\epsilon_1) + B(h, m-1)p_1P_c^{(f)}(\epsilon_1) \\ &\quad + G(h-1, m-1)q_1P_{ud}^{(f)}(\epsilon_1) \\ &\quad + B(h-1, m-1)p_1P_{ud}^{(f)}(\epsilon_1) \end{aligned} \quad (47b)$$

$$\begin{aligned} B(h, m) &= B(h, m-1)q_2P_c^{(f)}(\epsilon_2) + G(h, m-1)p_2P_c^{(f)}(\epsilon_2) \\ &\quad + B(h-1, m-1)q_2P_{ud}^{(f)}(\epsilon_2) \\ &\quad + G(h-1, m-1)p_2P_{ud}^{(f)}(\epsilon_2) \end{aligned} \quad (47c)$$

where

$$\begin{aligned} G(0, 1) &= P_c^{(f)}(\epsilon_1), \quad B(0, 1) = P_c^{(f)}(\epsilon_2) \\ G(1, 1) &= P_{ud}^{(f)}(\epsilon_1), \quad B(1, 1) = P_{ud}^{(f)}(\epsilon_2) \end{aligned} \quad (47d)$$

and  $G(h, m) = B(h, m) = 0$  when  $h < 0$  or  $h > m$ .

Note that if  $\epsilon_{a1/E} \approx \epsilon_{a2/E}$ , the upper bound of (45) is very close to (42). Fortunately, this is usually the case for  $0 < \epsilon_1 < \epsilon_2 < (1/2)$ , especially for small  $\epsilon_1$  and  $\epsilon_2$ , for then  $\epsilon_{a1/E} \approx \epsilon_{a2/E} \approx d_f/n$ .

To evaluate the system throughput, again assume that selective-repeat ARQ is used. In order to simplify the problem, we assume that retransmissions do not depend on the inner channel state during the previous transmission. This is a reasonable assumption if the channel roundtrip delay is large. Then the system throughput is given by (15) where  $P_c$ , the probability of correct decoding, can be found from

$$P_c = \frac{p_2}{p_1 + p_2} G(m) + \frac{p_1}{p_1 + p_2} B(m) \quad (48a)$$

and where

$$G(m) = G(m-1)q_1P_c^{(f)}(\epsilon_1) + B(m-1)p_1P_c^{(f)}(\epsilon_1) \quad (48b)$$

$$B(m) = B(m-1)q_2P_c^{(f)}(\epsilon_2) + G(m-1)p_2P_c^{(f)}(\epsilon_2) \quad (48c)$$

$$G(1) = P_c^{(f)}(\epsilon_1), \quad B(1) = P_c^{(f)}(\epsilon_2). \quad (48d)$$

#### D. Coding Examples on a Burst-Error Channel

For the inner channel, we choose  $P_n = 0.1$ ,  $\bar{L} = 5$ , and  $\epsilon_2/\epsilon_1 = 10$  and 1000 for our examples.

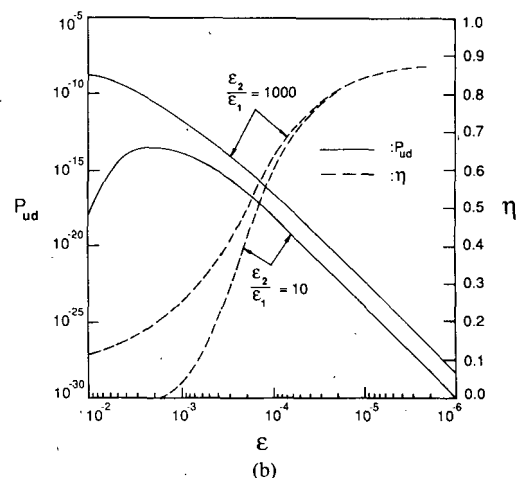
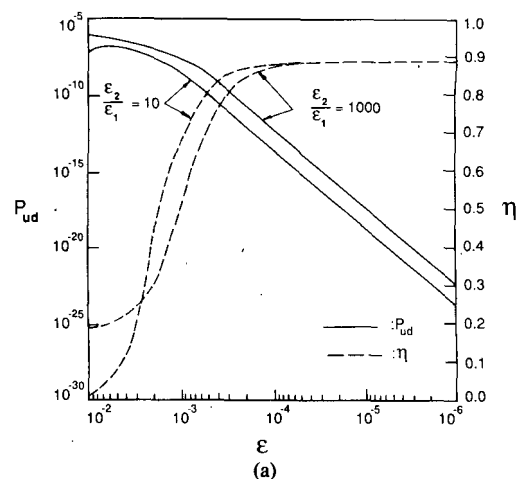

Fig. 9. (a) Performance of the concatenated code of Example 4 with  $m = 64$ ,  $IB = 7$ ,  $P_n = 0.1$ ,  $\bar{L} = 5$  (a)  $t = 1$ . (b)  $t = 0$ .

**Example 4:** The same frame and outer codes are used as in Example 2. The probability of undetected error  $P_{ud}$  and the system throughput  $\eta$  are plotted in Fig. 9(a) for  $t = 1$  and in Fig. 9(b) for  $t = 0$ , respectively.

The performance of the concatenated coding scheme on burst-error channels depends on the channel parameters, especially on the high-to-low BER ratio  $\epsilon_2/\epsilon_1$ . As shown in Fig. 9(a) and (b) for a given average BER  $\bar{\epsilon}$ , with the other parameters fixed, as the  $\epsilon_2/\epsilon_1$  ratio becomes large, the system performance becomes worse. Our results indicate that on a burst-error channel, for a moderate average BER, the system reliability degrades slightly, while the system throughput remains about the same, compared to the same coding scheme on an MBSC. This shows that the concatenated coding scheme is quite robust on a variety of channels.<sup>3</sup>

#### IV. CONCLUSIONS

In this paper, the performance of a concatenated coding scheme for error control in data communication is analyzed. By developing a block interference channel model for the outer channel, both the undetected error probability and the system throughput of the concatenated coding scheme were calculated for burst-error channels as well as random-error channels. The performance of several specific coding examples was compared.

In the examples, only those codes that require simple

<sup>3</sup> Therefore, if interleaving is also applied to the frame code, little performance improvement would be expected.



decoding were considered. Results indicate that high throughputs and extremely low undetected error probabilities are achievable using this scheme, even on burst-error channels. Therefore, the concatenated coding system is suitable for applications involving high-speed transmission, such as satellite telecommand systems and file transfer systems.

Although the performance analysis on the burst-error channel is presented for a two-state Markov chain model, the technique introduced can be readily extended to other types of burst-error channel models, such as the partitioned Markov chain model proposed by Fritchman [14], which has been used to model a variety of burst-error channels [15], [16].

## REFERENCES

- [1] T. Kasami, T. Fujiwara, and S. Lin, "A concatenated coding scheme for error control," *IEEE Trans. Commun.*, vol. COM-34, pp. 481-488, May 1986.
- [2] S. Lin and D. J. Costello, Jr., *Error Control Coding: Fundamentals and Applications*. Englewood Cliffs, NJ: Prentice-Hall, 1983.
- [3] L. R. Lugand and D. J. Costello, Jr., "A comparison of three hybrid ARQ schemes using convolutional codes on a non-stationary channel," in *Conf. Rec. GLOBECOM'82*, Miami, FL, Nov. 29-Dec. 2, 1982, p. C8.4.
- [4] E. N. Gilbert, "Capacity of a burst-noise channel," *Bell Syst. Tech. J.*, vol. 39, pp. 1253-1265, Sept. 1960.
- [5] E. O. Elliott, "Estimates of error rates for codes on burst-noise channels," *Bell Syst. Tech. J.*, vol. 42, pp. 1977-1997, Sept. 1963.
- [6] E. R. Berlekamp, *Algebraic Coding Theory*. New York: McGraw-Hill, 1968.
- [7] J. MacWilliams, "A theorem on the distribution of weights in a systematic code," *Bell Syst. Tech. J.*, vol. 42, pp. 79-94, 1963.
- [8] Z. McHuntoon and A. M. Michelson, "On the computation of the probability of post-decoding error events for block codes," *IEEE Trans. Inform. Theory*, vol. IT-23, pp. 399-403, May 1977.
- [9] R. J. McEliece and W. E. Stark, "Channels with block interference," *IEEE Trans. Inform. Theory*, vol. IT-30, pp. 44-53, Jan. 1984.
- [10] CCITT Recommendation X.25, "Interface between data terminal equipment for terminals operating in packet mode on public data networks," Plenary Assembly, Doc. No. 7, Geneva, Switzerland, 1980.
- [11] T. Fujiwara, T. Kasami, A. Kitai, and S. Lin, "On the probability of undetected error for shortened cyclic Hamming code," *IEEE Trans. Commun.*, vol. COM-33, pp. 570-574, June 1985.
- [12] J. K. Wolf, "Efficient maximum likelihood decoding of linear block codes using a trellis," *IEEE Trans. Inform. Theory*, vol. IT-24, pp. 76-80, Jan. 1978.
- [13] H. Yamamoto and K. Itoh, "Viterbi decoding algorithm for convolutional codes with repeat request," *IEEE Trans. Inform. Theory*, vol. IT-26, pp. 540-547, Sept. 1980.
- [14] B. D. Fritchman, "A binary channel characterization using partitioned Markov chains," *IEEE Trans. Inform. Theory*, vol. IT-13, pp. 221-227, Apr. 1967.
- [15] S. Tsai, "Markov characterization of the HF channels," *IEEE Trans. Commun. Technol.*, vol. COM-17, pp. 24-32, Feb. 1969.
- [16] S. Tsai and P. S. Schmied, "Interleaving and error-burst distribution," *IEEE Trans. Commun.*, vol. COM-20, pp. 291-296, June 1972.

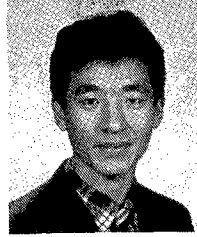

**Robert H. Deng** (M'86) was born in Hebei, China, on November 8, 1957. He received the B.E. degree in electronic engineering from Changsha Institute of Technology, Changsha, China, in 1981 and the M.S. and Ph.D. degrees in electrical engineering from the Illinois Institute of Technology, Chicago, in 1983 and 1985, respectively.

During 1982 he was with the Beijing Institute of Aeronautics and Astronautics, Beijing, China. Between 1984 and 1985 he was a Research Assistant on a NASA grant at the Department of Electrical and Computer Engineering, Illinois Institute of Technology. He is currently a Postdoctorate Research Associate at the Department of Electrical and Computer Engineering, University of Notre Dame, Notre Dame, IN. His research interests include error-control coding for digital communication systems, line coding for magnetic recording and optic fiber links, and trellis-coded modulations.

Dr. Deng is a member of the IEEE Information Theory and Communications Societies.

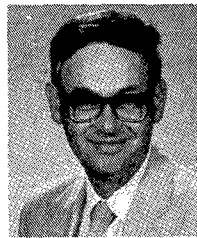

**Daniel J. Costello, Jr.** (M'69-SM'78-F'85) was born in Seattle, WA, on August 9, 1942. He received the B.S.E.E. degree from Seattle University, Seattle, in 1964 and the M.S. and Ph.D. degrees in electrical engineering from the University of Notre Dame, Notre Dame, IN, in 1966 and 1969, respectively.

In 1969 he joined the faculty of the Illinois Institute of Technology, Chicago, as an Assistant Professor of Electrical Engineering. He was promoted to Associate Professor in 1973 and to Full Professor in 1980. In 1985 he became Professor of Electrical and Computer Engineering at the University of Notre Dame. In addition, he has served as a professional consultant for Western Electric, the Illinois Institute of Technology Research Institute, Motorola Communications, and Digital Transmission Systems. His research interests are in the area of digital communications, with special emphasis on coding theory, information theory, multiuser systems, communication networks, error control, spread-spectrum communications, and coded modulation.

Dr. Costello belongs to the IEEE Information Theory Group and the Communications Society. Since 1983 he has been a member of the Information Theory Group Board of Governors and in 1986 served as President of the Board. He has also served as an Associate Editor of Communication Theory for the IEEE TRANSACTIONS ON COMMUNICATIONS and since 1983 has been an Associate Editor for Coding Techniques for the IEEE TRANSACTIONS ON INFORMATION THEORY. He has over 50 technical publications in his field, and coauthored (with Shu Lin) a textbook entitled *Error Control Coding: Fundamentals and Applications* (Prentice-Hall, 1983). He has served as principal investigator on more than a dozen research grants and has supervised more than a dozen Ph.D. dissertations.