

Mobile Genetic Elements Related to the Diffusion of Plasmid-Mediated AmpC β -Lactamases or Carbapenemases from *Enterobacteriaceae*: Findings from a Multicenter Study in Spain

L. Zamorano,^a E. Miró,^b C. Juan,^a L. Gómez,^b G. Bou,^c J. J. González-López,^{d,e} L. Martínez-Martínez,^f B. Aracil,^g M. C. Conejo,^h A. Oliver,^a  F. Navarro,^{b,e} the Spanish Network for Research in Infectious Diseases (REIPI)

Servicio de Microbiología and Unidad de Investigación, Hospital Universitario Son Espases, Instituto de Investigación Sanitaria de Palma (IdISPa), Palma de Mallorca, Spain^a; Servei de Microbiologia, Hospital de la Santa Creu i Sant Pau, Institut d'Investigació Biomèdica Sant Pau, Barcelona, Spain^b; Servicio de Microbiología, Complejo Hospitalario Universitario a Coruña, A Coruña, Spain^c; Servei de Microbiologia, Hospital Vall d'Hebrón, Barcelona, Spain^d; Departament de Genètica i Microbiologia, Universitat Autònoma de Barcelona, Barcelona, Spain^e; Servicio de Microbiología, Hospital Universitario Marqués de Valdecilla-IDIVAL, and Departamento de Biología Molecular, Universidad de Cantabria, Cantabria, Spain^f; Laboratorio de Antibióticos, Servicio de Bacteriología, Centro Nacional de Microbiología, Instituto de Salud Carlos III, Majadahonda, Madrid, Spain^g; Departamento de Microbiología, Facultad de Medicina, Universidad de Sevilla, Sevilla, Spain^h

We examined the genetic context of 74 acquired *ampC* genes and 17 carbapenemase genes from 85 of 640 *Enterobacteriaceae* isolates collected in 2009. Using S1 pulsed-field gel electrophoresis and Southern hybridization, 37 of 74 *bla*_{AmpC} genes were located on large plasmids of different sizes belonging to six incompatibility groups. We used sequencing and PCR mapping to investigate the regions flanking the acquired *ampC* genes. The *bla*_{CMY-2}-like genes were associated with *ISEcp1*; the surrounding *bla*_{DHA} genes were similar to *Klebsiella pneumoniae* plasmid pTN60013 associated with IS26 and the *psp* and *sap* operons; and the *bla*_{ACC-1} genes were associated with IS26 elements inserted into *ISEcp1*. All of the carbapenemase genes (*bla*_{VIM-1}, *bla*_{IMP-22}, and *bla*_{IMP-28}) were located in class 1 integrons. Therefore, although plasmids are the main cause of the rapid dissemination of *ampC* genes among *Enterobacteriaceae*, we need to be aware that other mobile genetic elements, such as insertion sequences, transposons, or integrons, can be involved in the mobilization of these genes of chromosomal origin. Additionally, three new integrons (In846 to In848) are described in this study.

Beta-lactam resistance in *Enterobacteriaceae* due to acquired AmpC β -lactamases (pAmpC) or carbapenemases represents an emerging and increasing problem that limits therapeutic options. pAmpC confer resistance to most β -lactams, except cefepime and carbapenems, whereas carbapenemases, including classes A, B, and D, can confer resistance to most β -lactams, including carbapenems. The number of *Enterobacteriaceae* isolates carrying these enzymes is lower than that of extended-spectrum β -lactamase-producing isolates, but the number has increased over the last few years, particularly for pAmpC CMY-2 and DHA and for carbapenemase types NDM, VIM, IMP, and OXA-48 (1, 2).

Both families of enzymes (pAmpC and carbapenemases) are normally codified in plasmids, and their genes are associated with mobile genetic elements (MGE), such as insertion sequences, transposon-like elements, and class 1 integrons. All of these MGE can transfer these genes into mobilizable and conjugative plasmids and subsequently disseminate them into many bacterial species that naturally lack these genes (3–5).

As previously described (3), 100,132 *Enterobacteriaceae* isolates were collected from February to July 2009 from 35 Spanish hospitals. Among them, we found a total of 674 *Enterobacteriaceae* isolates with acquired *ampC* and/or carbapenemase genes. The following enzyme types were found: CMY-2-like (74.3%), DHA (17.8%), ACC (1.5%), FOX (0.6%), VIM (4.3%), and IMP (1.5%) (3). Although a great genetic diversity among pAmpC-producing strains was observed, some clonal relationships were established between these isolates, mainly in carbapenemase-producing strains (3).

This study aimed to describe the plasmid families and the surrounding regions involved in the dissemination of a great

diversity of acquired *ampC* and metallo- β -lactamases genes in *Enterobacteriaceae* isolates lacking inducible chromosomal AmpC enzymes.

MATERIALS AND METHODS

Clinical isolates. To characterize the plasmids and flanking regions implicated in the expansion of these genes, we selected 85 strains from the collection cited above (3). The selection was made on the basis of prevalence, and strains that produced new enzymes were also included.

PCR-based replicon typing. PCR-based incompatibility (Inc)/replicon typing (PBRT) was used to identify the major Inc groups of the plasmids present (4, 6).

Plasmid profiles and Southern blot analysis. Plasmid analysis was carried out by DNA linearization with the S1 enzyme followed by pulsed-

Received 9 March 2015 Returned for modification 6 April 2015

Accepted 8 June 2015

Accepted manuscript posted online 15 June 2015

Citation Zamorano L, Miró E, Juan C, Gómez L, Bou G, González-López JJ, Martínez-Martínez L, Aracil B, Conejo MC, Oliver A, Navarro F, the Spanish Network for Research in Infectious Diseases (REIPI). 2015. Mobile genetic elements related to the diffusion of plasmid-mediated AmpC β -lactamases or carbapenemases from *Enterobacteriaceae*: findings from a multicenter study in Spain. *Antimicrob Agents Chemother* 59:5260–5266. doi:10.1128/AAC.00562-15.

Address correspondence to F. Navarro, fnavaror@santpau.cat.

Supplemental material for this article may be found at <http://dx.doi.org/10.1128/AAC.00562-15>.

Copyright © 2015, American Society for Microbiology. All Rights Reserved.

doi:10.1128/AAC.00562-15

TABLE 1 Flanking regions and plasmid families associated with acquired AmpC and carbapenemases in *Enterobacteriaceae*

<i>bla</i> gene(s)	Flanking region(s) ^a	Plasmid size(s) or localization (kb) ^b	Replicon	Microorganism(s) (no. of isolates)	
<i>bla</i> _{ACC-1}	ACC-1(B)	64.5	N	<i>K. pneumoniae</i> (1); <i>E. coli</i> (1)	
	ACC-1(B)	Chromosomal		<i>E. coli</i> (1); <i>Proteus mirabilis</i> (1)	
	ACC-1(B)	80	Unidentified	<i>K. pneumoniae</i> (1)	
	ACC-1(C)	32.5	Unidentified	<i>P. mirabilis</i> (1)	
<i>bla</i> _{ACC-1} + <i>bla</i> _{FOX-3}	ACC-1(D)	48.5	Unidentified	<i>K. pneumoniae</i> (1)	
	ACC-1(A) + FOX (A)	64.5 + 80.5	Unidentified + U	<i>E. coli</i> (1)	
	<i>bla</i> _{CMY-2}	CMY-2(A)	177.5 to 300.7	A/C	<i>K. pneumoniae</i> (2); <i>P. mirabilis</i> (1)
		CMY-2(A)	43.7 to 83.1	II	<i>Citrobacter koseri</i> (1); <i>E. coli</i> (4)
CMY-2(A)		69.3	I1 + FIB	<i>E. coli</i> (1)	
CMY-2(A)		48.5 to 83.1	K	<i>E. coli</i> (3); <i>K. pneumoniae</i> (1)	
CMY-2(A)		Chromosomal		<i>E. coli</i> (1); <i>Klebsiella oxytoca</i> (1)	
CMY-2(B)		55.4	K	<i>E. coli</i> (1)	
CMY-2(B)		76.2	II	<i>E. coli</i> (1)	
CMY-2(C)		145.5	II	<i>K. pneumoniae</i> (1)	
CMY-2(C)		Chromosomal		<i>P. mirabilis</i> (3); <i>K. pneumoniae</i> (1); <i>Proteus penneri</i> (1)	
CMY-2(D)		83.1 to 97.6	II	<i>E. coli</i> (1); <i>K. pneumoniae</i> (1)	
<i>bla</i> _{CMY-4}	CMY-2(A)	105.1	K + FIB	<i>E. coli</i> (1)	
	CMY-2(A)	Chromosomal		<i>E. coli</i> (1)	
	CMY-2(B)	80.8	II	<i>E. coli</i> (1)	
	CMY-2(C)	88.9	II	<i>K. pneumoniae</i> (1)	
<i>bla</i> _{CMY-7}	CMY-2(A)	80.8	II	<i>E. coli</i> (1)	
<i>bla</i> _{CMY-27}	CMY-2(A)	113.2	II	<i>E. coli</i> (2)	
<i>bla</i> _{CMY-43}	CMY-2(A)	Chromosomal		<i>E. coli</i> (1)	
<i>bla</i> _{CMY-48}	CMY-2(B)	Chromosomal		<i>E. coli</i> (1)	
<i>bla</i> _{CMY-54}	CMY-2(C)	105.1	K + FIB	<i>E. coli</i> (1)	
<i>bla</i> _{CMY-55}	CMY-2(A)	282.9	A/C	<i>E. coli</i> (1)	
<i>bla</i> _{CMY-56}	CMY-2(A)	299.1	A/C	<i>K. pneumoniae</i> (1)	
<i>bla</i> _{CMY-57}	CMY-2(C)	97.0	II	<i>E. coli</i> (1)	
<i>bla</i> _{CMY-2} + <i>bla</i> _{DHA-1}	CMY-2(A) + DHA-1(G)	Chromosomal + 218	FIIA	<i>K. pneumoniae</i> (1)	
<i>bla</i> _{CMY-2} + <i>bla</i> _{VIM-1}	CMY-2(C) + VIM-1(B)	Chromosomal + 48	Unidentified	<i>P. mirabilis</i> (1)	
<i>bla</i> _{DHA-1}	DHA-1(A)	72.8 to 87.3	Unidentified	<i>C. koseri</i> (1); <i>E. coli</i> (1); <i>K. pneumoniae</i> (2)	
	DHA-1(A)	203.7	A/C	<i>K. pneumoniae</i> (1)	
	DHA-1(A)	Chromosomal		<i>C. koseri</i> (1); <i>Enterobacter cloacae</i> (1)	
	DHA-1(B)	72.8	Unidentified	<i>K. oxytoca</i> (2)	
	DHA-1(B)	77.6	II	<i>E. coli</i> (1)	
	DHA-1(C)	Chromosomal		<i>P. mirabilis</i> (3)	
	DHA-1(D)	72.8	Unidentified	<i>K. oxytoca</i> (1)	
	DHA-1(E)	72.8	Unidentified	<i>Salmonella</i> spp. (1)	
	DHA-1(F)	87.3	Unidentified	<i>E. coli</i> (1)	
	DHA-1(H)	Chromosomal		<i>E. coli</i> (1)	
	DHA-1(G)	87.3	II	<i>E. coli</i> (1)	
	<i>bla</i> _{DHA-6}	DHA-1(G)	87.3	II	<i>E. coli</i> (1)
	<i>bla</i> _{DHA-1} + <i>bla</i> _{VIM-1}	DHA-1(B) + VIM-1 (D) (In846)	76.6 + chromosomal	FIIA	<i>K. pneumoniae</i> (1)
	<i>bla</i> _{DHA-7} + <i>bla</i> _{VIM-1}	DHA-1(D) + VIM-1(E) (In847)	310.4 + 48.5	HI2 + unidentified	<i>E. cloacae</i> (2)
	<i>bla</i> _{FOX-3}	FOX(A)	72.5	U	<i>E. coli</i> (1)
	<i>bla</i> _{FOX-8}	FOX(A)	Chromosomal		<i>E. coli</i> (2)
	<i>bla</i> _{IMP-22}	IMP-22(A)	485.0	Unidentified	<i>K. pneumoniae</i> (2)
<i>bla</i> _{IMP-28}	IMP-28(A) (In767)	Chromosomal		<i>K. oxytoca</i> (1)	
<i>bla</i> _{VIM-1}	VIM-1(A) (In488)	48.0	Unidentified	<i>K. oxytoca</i> (1)	
	VIM-1(B) (In624)	48.0 and 66.2	Unidentified	<i>E. cloacae</i> (2); <i>K. oxytoca</i> (2); <i>K. pneumoniae</i> (2)	
	VIM-1(C) (In846)	48.0 and 72.5	U	<i>K. pneumoniae</i> (1); <i>E. cloacae</i> (1)	
	VIM-1(D) (In848)	48.0	Unidentified	<i>E. coli</i> (1)	

^a The type of surrounding regions found for each *bla* gene is in parentheses (see Fig. 1 to 3 for more data).

^b The plasmid size was determined after the hybridization procedure. Chromosomal means possible chromosomal localization of the gene.

field gel electrophoresis (PFGE), as previously described (7). Plasmid sizes were estimated using Fingerprinting II Informatics software (Bio-Rad) (7). A PCR Dig probe synthesis kit (Roche Diagnostics GmbH, Mannheim, Germany) was used to obtain *bla*_{AmpC} or Inc probes for hybridization of

the S1-PFGE blots. These probes were labeled with the commercial kit (Dig high-prime DNA labeling and detection starter kit II; Roche Diagnostics GmbH).

The chromosomal location of *bla* genes was analyzed by digesting the

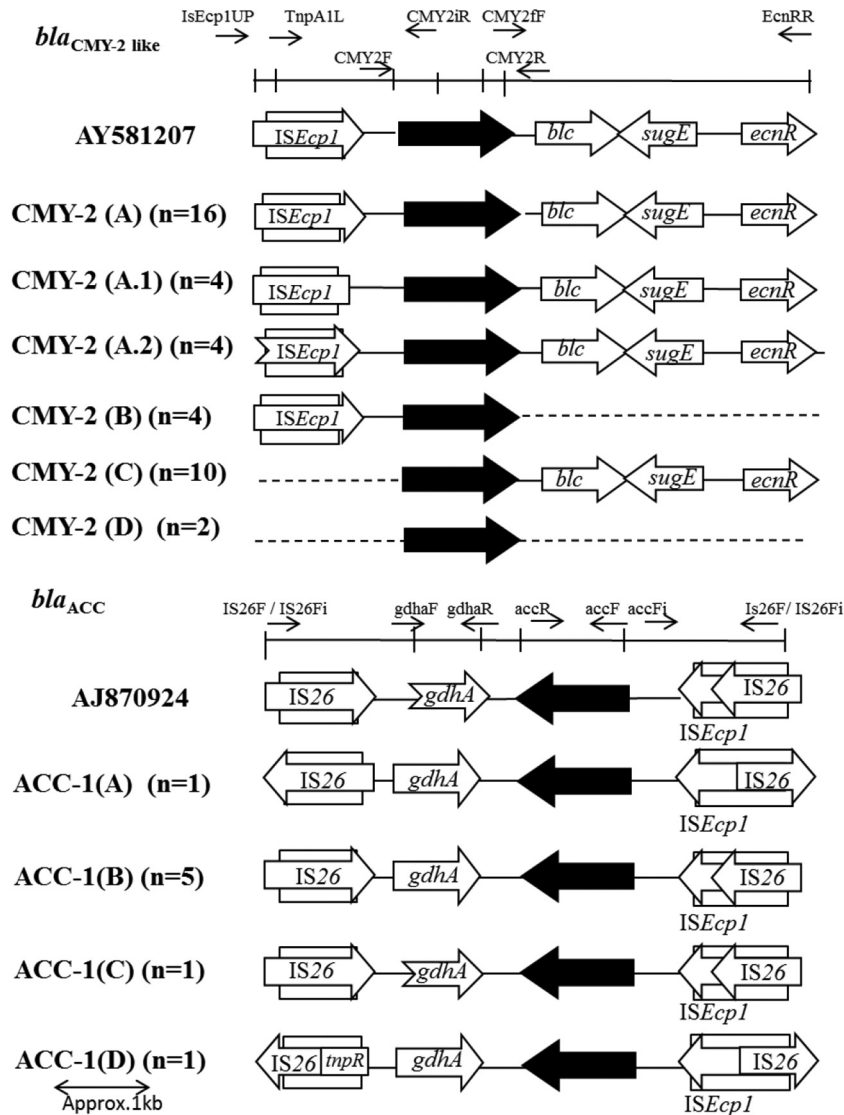

FIG 1 The genetic environment of *bla*_{CMY-2-like} and *bla*_{ACC} genes, which are indicated by solid black arrows; the surrounding genes are indicated by white arrows. The dashed lines indicate the areas that could not be amplified by PCR. Eight isolates contained truncated versions of *ISEcp1* at the 3' end (A.1) and the 5' end (A.2). Truncated genes are indicated by disrupted arrows. One isolate (C) carrying the *bla*_{ACC} gene showed a structure identical to that of GenBank accession no. AJ870924. In one isolate (D), *IS26* was truncated by a *mpR* gene of insertion Tn5393. The primers used for PCR amplification are also shown.

genomic DNA with the ICEuI enzyme, followed by PFGE and hybridization blotting as described above.

Genetic environment characterization of acquired *ampC* and carbapenemase genes. The genetic context was investigated by exploring the regions surrounding acquired *bla*_{AmpC} and carbapenemase genes frequently reported in the literature (8–14), employing PCR and sequencing with previously described primers. Additionally, primers designed in accordance with accessible DNA sequences in GenBank (accession numbers AY581207, AJ870924, Y11068, AJ971345, and EF577408) were used to ascertain the presence of genes linked to the acquired *bla*_{AmpC} and carbapenemase genes (see Table S1 in the supplemental material). Sequencing reactions were performed with the BigDye terminator kit (PE Applied Biosystems, Foster City, CA), and sequences were analyzed on an ABI Prism 3100 DNA sequencer (PE Applied Biosystems). The resulting sequences were then compared with those available in the GenBank database (www.ncbi.nih.gov/BLAST).

Nucleotide sequence accession numbers. Sequences with new integrons were submitted to GenBank under the accession numbers KC417378 (In846), KC417379 (In847), and KC417377 (In848).

RESULTS

Among the 85 selected strains (66 pAmpC-producing strains, 13 IMP/VIM-producing strains, 4 strains that produced both enzymes, and 2 strains that produced two pAmpC), we characterized the plasmids and flanking regions of 91 genes: 74 *bla*_{AmpC} genes, 3 *bla*_{IMP} genes, and 14 *bla*_{VIM} genes (Table 1).

The studied *bla*_{AmpC} genes included *bla*_{CMY-2-like} (40), *bla*_{DHA} (22), *bla*_{ACC} (8), and *bla*_{FOX} (4), while the metallo-β-lactamase genes included *bla*_{VIM-1} (14), *bla*_{IMP-22} (2), and *bla*_{IMP-28} (1).

Plasmid characterization. Analysis by S1-PFGE and Southern hybridization allowed us to determine the plasmid size for 74.7%

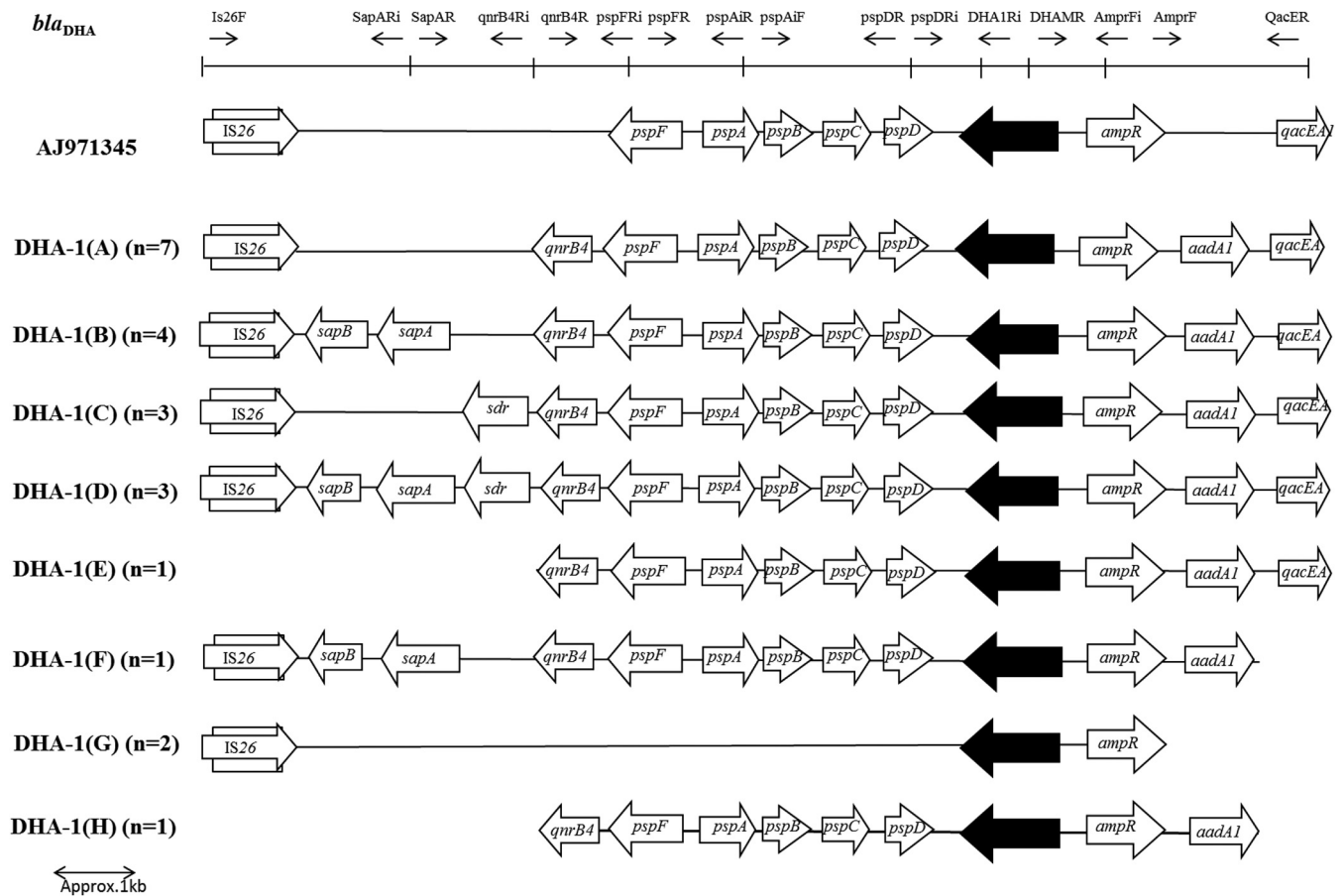

FIG 2 The genetic environment of the *bla*_{DHA} gene, which is indicated by solid black arrows; the surrounding genes are indicated by white arrows. Lines indicate an absence of the corresponding DNA fragments.

(68 of 91) of the studied genes, leaving 23 genes (25.3%) with a possible chromosomal location (positive hybridization in ICeU-PFGE). Nevertheless, we were able to describe the incompatibility group by PCR-based replicon typing (PBRT) among these 68 plasmidic genes in only 41 cases (60.3%).

We found that 39 of 74 *bla*_{AmpC} genes (50%) were located in large plasmids of different sizes belonging to eight Inc groups, including A/C, FIB, FIIA, I1, K, HI2, N, and U. The most representative, present alone or together with other replicons, were I1 ($n = 18$; one also with FIB), K ($n = 7$; two also with FIB), A/C ($n = 6$), FIIA ($n = 2$), HI2 ($n = 2$), and N ($n = 2$) (Table 1). In 13 of 74 *bla*_{AmpC} genes (17.5%), the plasmid replicon was not identified. (In 10 cases, PBRT was positive for different replicons, but their hybridization bands did not match the *bla*_{AmpC} band, and PBRT was negative in 3 cases.) Finally, in 22 cases (29.7%), a possible chromosomal location of these genes was confirmed by ICeU-PFGE.

The plasmids carrying *bla*_{CMY-2}-like genes belonged to the following Inc groups: I1 (16 of 40 [37.5%]; sizes ranged from 43.7 to 145.5 kb), K (7 of 40 [17.5%]; sizes ranged from 48.5 to 105.1 kb), and A/C (5 of 40 [12.5%]; sizes ranged from 177.5 to 300.7 kb). In three cases, the FIB plasmid was also found to be associated with one IncI1 or two IncK plasmids (Table 1).

Seven of 22 plasmids carrying *bla*_{DHA} genes were characterized, and the following Inc groups were found: I1 (9%; 77.6 and 87.3

kb), FIIA (9%; 76.6 and 218 kb), HI2 (9%; 291 kb), and A/C (4.5%; 203.7 kb). The remaining 15 cases were not resolved because no incompatibility group probes were hybridized ($n = 11$) or because of a negative PBRT ($n = 4$).

Only 2 of the 8 plasmids carrying *bla*_{ACC-1} were identified, and they belonged to the IncN group, with sizes ranging from 32.5 to 80 kb. The *bla*_{FOX-3} genes were found in plasmids of 72.5 and 80.5 kb, both in the IncU group, and the *bla*_{FOX-8} gene (15) was probably located on the chromosome.

Finally, the sizes of the 14 plasmids carrying the *bla*_{VIM-1} gene ranged from 48 to 72.5 kb, and one of them belonged to the IncU group; the *bla*_{IMP-22} genes were in plasmids of 485 kb with an unidentified Inc group. The *bla*_{IMP-28} gene was probably located on the chromosome, as previously described (16).

Detection of the flanking regions of acquired *ampC* and metallo- β -lactamase genes. The variable genetic environments detected for the most prevalent enzymes (CMY-2-like, DHA, ACC, and metallo- β -lactamase genes) are shown in Fig. 1, 2, and 3.

The analysis of the genetic environment revealed that *bla*_{CMY-2}-like genes (*bla*_{CMY-2}, *bla*_{CMY-4}, *bla*_{CMY-7}, *bla*_{CMY-27}, *bla*_{CMY-48}, *bla*_{CMY-54} and/or *bla*_{CMY-57}, *bla*_{CMY-59}, and *bla*_{CMY-60}) were associated with ISEcpl1, responsible for the transfer of the *bla*_{CMY-2}-like-*blc-sugE* region from the chromosome of *Citrobacter freundii* to plasmids (8). In our study, 16 strains contained ISEcpl1 and *blc-sugE-ecrR* upstream and downstream of *bla*_{CMY-2}-like genes,

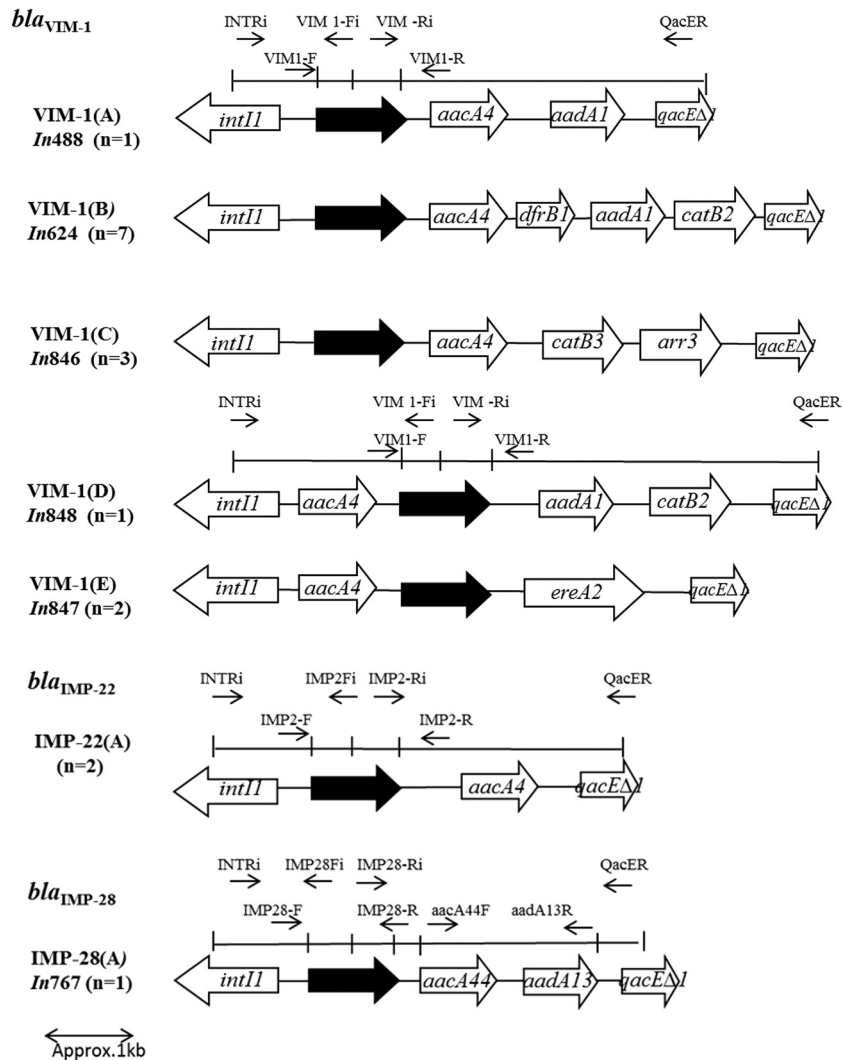

FIG 3 Structure of *bla*_{VIM-1}, *bla*_{IMP-22}, and *bla*_{IMP-28} genes carrying the integrons described in this work. Carbapenemase genes are indicated by solid black arrows, and the surrounding genes are indicated by white arrows. The locations of the primers used for PCR amplification are also shown.

respectively. However, truncation of *ISEcp1*(Δ *ISEcp1*) was observed in 8 strains: in 4 at the 3' end and in 4 at the 5' end. In the 4 strains with truncation at the 3' end, primers described to explore this region (*ISEcp1* and *CMY2Ri*) (see Table S1 in the supplemental material) amplified a product of 1,560 bp instead of the expected 2,160 bp. In the 4 strains with truncation at the 5' end, the amplicons were not obtained using *ISEcp1* and *CMY2Ri* primers, and we required a new pair of primers (*TnpA1L* and *CMY2Ri*). Finally, 12 strains did not contain *ISEcp1* upstream, and the region downstream of the *bla*_{CMY-2}-like gene could not be amplified by PCR in 6 strains with the primers used. Only in 2 strains with complete *bla*_{CMY-2}-like genes was the genetic environment unknown (Fig. 1).

The surrounding regions of *bla*_{DHA} genes (*bla*_{DHA-1}, *bla*_{DHA-6}, and *bla*_{DHA-7}) were similar to those previously described in *Klebsiella pneumoniae* plasmid pTN60013 (GenBank accession number AJ971345) (5), although a certain variability was detected in accordance with the literature data (11, 17). This variability mainly concerned the absence or presence of *sapB*, *sapA*, and *sdr*

genes (Fig. 2). The quinolone resistance determinant *qnrB4* and additional *aadA1* (streptomycin and spectinomycin resistance) genes were detected in most of the strains. This linkage between *bla*_{DHA-1} and *qnrB4* genes has been previously described in isolates of *K. pneumoniae* (11).

In the environment of the *bla*_{ACC} gene, *ISEcp1* and the *gdhA* gene were detected upstream and downstream, respectively. In all cases, *ISEcp1* was truncated in the 5' end (13). Six of eight *bla*_{ACC} genes showed two *IS26* copies in the same orientation; one of these strains contained a truncated 5' *gdhA*, and one contained a *tnpR* gene of Tn5393 upstream of the *gdhA* gene.

Four *bla*_{FOX} genes, *bla*_{FOX-3} ($n = 2$) and *bla*_{FOX-8} ($n = 2$), were located in a class I integron, at the 5' end of the integrase *INI1*, and several attempts to identify the 3' end by PCR were unsuccessful.

All the metallo- β -lactamase genes (14 *bla*_{VIM-1}, 2 *bla*_{IMP-22}, and 1 *bla*_{IMP-28}) were located in class I integrons (In). In this study, we detected 5 different structures harboring *bla*_{VIM} genes (Fig. 3); In846 (GenBank accession number KC417378), In847 (KC417379), and In848 (KC417377) were described for the first time.

DISCUSSION

We have characterized the genetic context of the largest available collection of acquired AmpC β -lactamases and metallo- β -lactamases in *Enterobacteriaceae* lacking inducible chromosomal AmpC enzymes recovered during 2009 from 35 Spanish hospitals (3).

Several authors have related the spread of different acquired AmpC genes with the expansion of plasmids of certain incompatibility groups (1, 2, 4, 5, 7, 18–21). In this context, the *bla*_{CMY-2} gene is associated with plasmids of I1, A/C, and K incompatibility groups (7, 18–21). Our results match these data, but differences were found in the percentage of each incompatibility group. In a previous study (7) carried out during 1999 to 2007, A/C was the most predominant incompatibility group found (33%) among plasmids carrying *bla*_{CMY-2}, followed by I1 (23%) and K (10%). In this study (with strains isolated in 2009), the most prevalent incompatibility group was I1 (40%), followed by K (17.5%) and A/C (12.5%). The fact that different Inc plasmids have been found to carry the same resistance gene is an indication of a successful and widespread distribution; moreover, this variability contributes to the genetic environment of these genes (20). The IncA/C and IncI1 are considered epidemic plasmids, because they are found in different countries and in bacteria of diverse origin, and because they carry a range of resistance mechanisms (4). IncA/C plasmids have been described carrying ESBLs that are TEM-type or VEB, as well as NDM-1 carbapenemase. On the other hand, IncI1 has an efficient conjugative system that could also contribute to the dissemination of different resistance mechanisms, such as ESBLs that are CTX-M-type and TEM-type (4).

The genetic environment of *bla*_{CMY-2} and its variants was highly conserved; 60% of isolates carried the transposon-like elements *ISEcp1* (*ISEcp1*/ Δ *ISEcp1*-*bla*_{CMY}-*blc*-*sugE*), as documented in previous reports (8, 10, 18). As these *bla*_{CMY-2}-derived *bla*_{CMY} genes differ from one other by only a few nucleotide substitutions, it is possible that these differences could have evolved within the same Inc plasmid (I1) (20). The genes *bla*_{CMY-55} and *bla*_{CMY-56} were found in the A/C plasmid, and the *bla*_{CMY-54} gene was found in a K plasmid, in this case cointegrated with FIB.

The *bla*_{DHA-1} genes were initially associated with IncFII plasmids (20), but recent studies link them with IncL/M plasmids and *qnrB* determinants (5, 7). Among our DHA-producing strains, 19 showed the *qnrB4* determinant (data not shown), and none was associated with the IncL/M plasmids. In fact, we were able to characterize the plasmid in only 7 cases (38.8%); I2, FIIA, and HI2 were the incompatibility groups found. The genetic organization of *bla*_{DHA} genes was more variable. Mobilization of this enzyme has been associated with IS26 or class 1 integron-bearing *ISCR1* elements (11, 18). Among *bla*_{DHA}-carrying isolates, 86% were associated with IS26.

In the literature, characterization of plasmids carrying *bla*_{ACC-1} genes is scarce. In a previous study, a *bla*_{ACC-1} gene in an *Escherichia coli* strain was found in an IncI1 plasmid (7), but other authors could not type it (21). Regarding the genetic context of *bla*_{ACC-1} genes, an *ISEcp1* element truncated at the 5' end with an IS26 insertion sequence was found in all of our *bla*_{ACC-1}-carrying isolates, as described in previous reports (12, 13).

*bla*_{FOX} and all carbapenemases detected in this study, including previously undescribed structures (in *bla*_{FOX}), were located in a class 1 integron and present in the most recent IncU plasmids.

There are few data on the types of plasmids involved in the spread of metallo- β -lactamases. In the literature, *bla*_{IMP} and *bla*_{VIM} genes are described in plasmids of incompatibility groups I1, N, W, and HI2 (4). In this study, the *bla*_{IMP-22} gene was located in a 485-kb plasmid of an uncharacterized incompatibility group, and two *bla*_{VIM-1} genes were found in IncU plasmids, curiously both isolated from different species but in the same hospital. Finally, the location of the *bla*_{IMP-28} gene seems to be chromosomal, as *bla*_{IMP-28}-positive hybridization was found in the ICeU1-PFGE membrane.

Accordingly, the high number of unidentified replicons could be associated with plasmids other than those tested; alternatively, they could be associated with one of the tested plasmids, albeit with some genetic variability, as has been described for the carbapenemase NDM in plasmids with a variant of the IncN or IncHI1 groups (4).

In conclusion, although plasmids have proven to be one of the main causes of the rapid dissemination of *bla*_{AmpC} and carbapenemase genes among bacteria, other MGE must play an important role in the increasing prevalence of these enzymes. Further studies, focused not only on plasmids but also on other MGE, such as insertion sequences, transposons, or integrative conjugative elements, are needed to gain a better understanding of the complex process involved in the dissemination of antibiotic resistance genes worldwide.

ACKNOWLEDGMENTS

This study was partially supported by the Ministry of Health and Consumer Affairs, Instituto de Salud Carlos III-Feder, Spanish Network for Research in Infectious Diseases (REPI/RD06/0008/0013 and FIS 09/0125), and the Spanish Ministry of Education (BFU2008-00995/BMC).

REFERENCES

1. Castanheira M, Farrell SE, Krause KM, Jones RN, Sader HS. 2014. Contemporary diversity of β -lactamases among *Enterobacteriaceae* in the nine U.S. census regions and ceftazidime-avibactam activity tested against isolates producing the most prevalent β -lactamase groups. *Antimicrob Agents Chemother* 58:833–838. <http://dx.doi.org/10.1128/AAC.01896-13>.
2. Lascos C, Peirano G, Hackel M, Laupland KB, Pitout JDD. 2013. Surveillance and molecular epidemiology of *Klebsiella pneumoniae* isolates that produce carbapenemases: first report of OXA-48-like enzymes in North America. *Antimicrob Agents Chemother* 57:130–136. <http://dx.doi.org/10.1128/AAC.01686-12>.
3. Miró E, Agüero J, Larrosa MN, Fernández A, Conejo MC, Bou G, González-López JJ, Lara N, Martínez-Martínez L, Oliver A, Aracil B, Oteo J, Pascual A, Rodríguez-Baño J, Zamorano L, Navarro F. 2013. Prevalence and molecular epidemiology of acquired AmpC β -lactamases and carbapenemases in *Enterobacteriaceae* isolates from 35 hospitals in Spain. *Eur J Clin Microbiol Infect Dis* 32:253–259. <http://dx.doi.org/10.1007/s10096-012-1737-0>.
4. Carattoli A. 2013. Plasmids and the spread of resistance. *Int J Med Microbiol* 303:298–304. <http://dx.doi.org/10.1016/j.ijmm.2013.02.001>.
5. Mata C, Miró E, Mirelis B, Garcillán-Barcia MP, de la Cruz F, Coll P, Navarro F. 2010. *In vivo* transmission of a plasmid coharbouring *bla*_{DHA-1} and *qnrB* genes between *Escherichia coli* and *Serratia marcescens*. *FEMS Microbiol Lett* 308:24–28. <http://dx.doi.org/10.1111/j.1574-6968.2010.01980.x>.
6. Carattoli A, Bertini A, Villa L, Falbo V, Hopkins KL, Threlfall EJ. 2005. Identification of plasmids by PCR-based replicon typing. *J Microbiol Methods* 63:219–228. <http://dx.doi.org/10.1016/j.jmimet.2005.03.018>.
7. Mata C, Miró E, Alvarado A, Garcillán-Barcia MP, Toleman M, Walsh TR, de la Cruz F, Navarro F. 2012. Plasmid typing and genetic context of AmpC β -lactamases in *Enterobacteriaceae* lacking inducible chromosomal *ampC* genes: findings from a Spanish hospital 1999 to 2007. *J Antimicrob Chemother* 67:115–122, 2012. <http://dx.doi.org/10.1093/jac/dkr412>.

8. Verdet C, Gautier V, Chachaty E, Ronco E, Hidri N, Decré D, Arlet G. 2009. Genetic context of plasmid-carried *bla*_{CMY-2}-like genes in *Enterobacteriaceae*. *Antimicrob Agents Chemother* 53:4002–4006. <http://dx.doi.org/10.1128/AAC.00753-08>.
9. Wei ZQ, Chen YG, Yu YS, Lu WX, Li LJ. 2005. Nosocomial spread of multiresistant *Klebsiella pneumoniae* containing a plasmid encoding multiple β -lactamases. *J Med Microbiol* 54:885–888. <http://dx.doi.org/10.1099/jmm.0.46151-0>.
10. Kang MS, Besser TE, Call DR. 2006. Variability in the region downstream of the *bla*_{CMY-2} β -lactamase gene in *Escherichia coli* and *Salmonella enterica* plasmids. *Antimicrob Agents Chemother* 50:1590–1593. <http://dx.doi.org/10.1128/AAC.50.4.1590-1593.2006>.
11. Verdet C, Benzerara Y, Gautier V, Adam O, Ould-Hocine Z, Arlet G. 2006. Emergence of DHA-1-producing *Klebsiella* spp. in the Parisian region: genetic organization of the *ampC* and *ampR* genes originating from *Morganella morganii*. *Antimicrob Agents Chemother* 50:607–617. <http://dx.doi.org/10.1128/AAC.50.2.607-617.2006>.
12. Partridge SR. 2007. Genetic environment of *ISEcp1* and *bla*_{ACC-1}. *Antimicrob Agents Chemother* 51:2658–2659. <http://dx.doi.org/10.1128/AAC.00364-07>.
13. Doloy A, Verdet C, Gautier V, Decré D, Ronco E, Hammami A, Philippon A, Arlet G. 2006. Genetic environment of acquired *bla*_{ACC-1} β -lactamase gene in *Enterobacteriaceae* isolates. *Antimicrob Agents Chemother* 50:4177–4181. <http://dx.doi.org/10.1128/AAC.00619-06>.
14. Gutiérrez O, Juan C, Cercenado E, Navarro F, Bouza E, Coll P, Pérez JL, Oliver A. 2007. Molecular epidemiology and mechanisms of carbapenem resistance in *Pseudomonas aeruginosa* isolates from Spanish hospitals. *Antimicrob Agents Chemother* 51:4329–4335. <http://dx.doi.org/10.1128/AAC.00810-07>.
15. Pérez-Llarena FJ, Kerff F, Zamorano L, Fernández MC, Nuñez ML, Miró E, Oliver A, Navarro F, Bou G. 2013. Characterization of the new AmpC β -lactamase FOX-8 reveals a single mutation, Phe313Leu, located in the R2 loop that affects ceftazidime hydrolysis. *Antimicrob Agents Chemother* 57:5158–5161. <http://dx.doi.org/10.1128/AAC.00818-13>.
16. Pérez-Llarena FJ, Fernández A, Zamorano L, Kerff F, Beceiro A, Aracil B, Cercenado E, Miro E, Oliver A, Oteo J, Navarro F, Bou G. 2012. Characterization of a novel IMP-28 metallo- β -lactamase from a Spanish *Klebsiella oxytoca* clinical isolate. *Antimicrob Agents Chemother* 56:4540–4543. <http://dx.doi.org/10.1128/AAC.00776-12>.
17. Jiang Y, Yu D, Wei Z, Shen P, Zhou Z, Yu Y. 2010. Complete nucleotide sequence of *Klebsiella pneumoniae* multidrug resistance plasmid pKP048, carrying *bla*_{KPC-2}, *bla*_{DHA-1}, *qnrB4*, and *armA*. *Antimicrob Agents Chemother* 54:3967–3969. <http://dx.doi.org/10.1128/AAC.00137-10>.
18. Naseer U, Haldorsen B, Simonsen GS, Sundsfjord A. 2010. Sporadic occurrence of CMY-2-producing multidrug-resistant *Escherichia coli* of ST-complexes 38 and 448, and ST131 in Norway. *Clin Microbiol Infect* 16:171–178. <http://dx.doi.org/10.1111/j.1469-0691.2009.02861.x>.
19. Folster JP, Pecic G, Singh A, Duval B, Rickert R, Ayers S, Abbott J, McGlinchey B, Bauer-Turpin J, Haro J, Hise K, Zhao S, Fedorka-Cray PJ, Whichard J, McDermott PF. 2012. Characterization of extended-spectrum cephalosporin-resistant *Salmonella enterica* serovar Heidelberg isolated from food animals, retail meat, and humans in the United States 2009. *Foodborne Pathog Dis* 9:638–645. <http://dx.doi.org/10.1089/fpd.2012.1130>.
20. Hopkins KL, Liebana E, Villa L, Batchelor M, Threlfall EJ, Carattoli A. 2006. Replicon typing of plasmids carrying CTX-M or CMY β -lactamases circulating among *Salmonella* and *Escherichia coli* isolates. *Antimicrob Agents Chemother* 50:3203–3206. <http://dx.doi.org/10.1128/AAC.00149-06>.
21. Dierikx C, van Essen-Zandbergen A, Veldman K, Smith H, Mevius D. 2010. Increased detection of extended spectrum β -lactamase producing *Salmonella enterica* and *Escherichia coli* isolates from poultry. *Vet Microbiol* 145:273–278. <http://dx.doi.org/10.1016/j.vetmic.2010.03.019>.