

On the (In)Succinctness of Muller Automata*

Udi Boker

Interdisciplinary Center (IDC), Herzliya, Israel

Abstract

There are several types of finite automata on infinite words, differing in their acceptance conditions. As each type has its own advantages, there is an extensive research on the size blowup involved in translating one automaton type to another.

Of special interest is the Muller type, providing the most detailed acceptance condition. It turns out that there is inconsistency and incompleteness in the literature results regarding the translations to and from Muller automata. Considering the automaton size, some results take into account, in addition to the number of states, the alphabet length and the number of transitions while ignoring the length of the acceptance condition, whereas other results consider the length of the acceptance condition while ignoring the two other parameters.

We establish a full picture of the translations to and from Muller automata, enhancing known results and adding new ones. Overall, Muller automata can be considered less succinct than parity, Rabin, and Streett automata: translating nondeterministic Muller automata to the other nondeterministic types involves a polynomial size blowup, while the other way round is exponential; translating between the deterministic versions is exponential in both directions; and translating nondeterministic automata of all types to deterministic Muller automata is doubly exponential, as opposed to a single exponent in the translations to the other deterministic types.

1998 ACM Subject Classification D.2.4 Software/Program Verification, F.4 Mathematical Logic and Formal Languages

Keywords and phrases Automata, Omega-regular languages, Determinization

Digital Object Identifier 10.4230/LIPIcs.CSL.2017.12

1 Introduction

Automata on infinite words were introduced in the 60's, in the course of solving fundamental decision problems in mathematics and logic [4, 14, 10, 16]. Today, they are widely used in formal verification and synthesis of nonterminating systems, where their size and the complexity of performing operations on them play a key role. Unlike automata on finite words, there are several types of automata on infinite words, differing in their acceptance conditions, most notably Büchi [4], Muller [14], Rabin [16], Streett [21], and parity [13]. Each of the types has its own advantages, for which reason there is an extensive research on the size blowup involved in the translations between them [10, 17, 18, 15, 22, 5, 19, 2, 20].

The size of an automaton can be generally viewed as the sum (or maximum) of its element sizes, namely the maximum of the alphabet length, the number of states, the number of transitions, and the index, where the latter denotes the size of the acceptance condition. For Büchi automata the index is 1, for parity it can be as large as the number of states, and for Rabin, Streett, and Muller it can be exponentially larger than the number of states.

When analyzing translations between automata, the first measure to consider is the size blowup, while a second consideration is the influence of and on each of the automaton

* This work was supported by the Israel Science Foundation grant 1373/16.



© Udi Boker;

licensed under Creative Commons License CC-BY

26th EACSL Annual Conference on Computer Science Logic (CSL 2017).

Editors: Valentin Goranko and Mads Dam; Article No. 12; pp. 12:1–12:16

Leibniz International Proceedings in Informatics



LIPIC Schloss Dagstuhl – Leibniz-Zentrum für Informatik, Dagstuhl Publishing, Germany

elements. For example, nondeterministic Büchi automata of size n can be translated to deterministic Rabin automata of size in $2^{O(n \log n)}$; The constructed Rabin automata have, by some algorithms, an index in $O(n)$ [17], while by others it is in $2^{O(n)}$ and the number of states is slightly smaller [19].

In addition to the number of states and the index, a central element to consider is the alphabet length, which might be exponentially larger than the number of states. There are cases in which the alphabet length has no influence on the size blowup (e.g. [22]) and others in which it significantly influences it (e.g. [7]). For lower bound results, the aim is to provide a family of languages over a fixed alphabet. Considering the Büchi-determinization example, Michel provided a matching lower bound of $2^{\Omega(n \log n)}$ [11], however he used Büchi automata over alphabets of length linear in the number of states (and therefore with quadratically many transitions). Afterwards, Löding improved the lower bound to be over a fixed alphabet [9]. An often productive approach is to start with a rich alphabet of length exponential in the number of states, get a lower bound with respect to the number of states, while ignoring the alphabet length and the number of transitions, and then enhance it to be over a fixed alphabet [22, 3]. The challenge in this approach is to encode the rich alphabet by a fixed one without enlarging the number of states.

Less central is the number of transitions, which might be as large as the product of the alphabet length and quadratically the number of states. Nevertheless, this element is often taken into account in analyzing the size blowup [8, 19]. Moreover, in recent years there is a growing interest in automata with acceptance labeling on transitions rather than on states (e.g. [5]), further increasing the importance of this element.

We concentrate on the translations to and from Muller automata. It turns out that there is inconsistency and incompleteness in the literature results regarding these translations.

The Muller condition explicitly lists the exact subsets of states that may be visited infinitely often along an accepting run. This is in distinction to other types, such as Rabin and Streett, which specify a list of constraints on the subsets of states that are visited infinitely often. It is therefore reasonable to assume that Rabin and Streett automata can be exponentially more succinct than Muller automata, which is indeed the case [17].

An interesting question is whether the explicit Muller condition can allow for automata that are exponentially more succinct than the other types. The literature answer seems to be yes. In [9], there is an exponential lower bound for the translation of deterministic Streett to deterministic Rabin automata, and vice versa. It is claimed there that these lower bounds also hold for the translations of deterministic Muller to deterministic Rabin and Streett automata. However, a closer look at the family of Streett automata that is used in the lower-bound proof suggests that equivalent deterministic Muller automata need an index exponential in the number of states. Thus, they are not exponentially smaller than the equivalent deterministic Rabin automata. Another candidate family of languages $\{L_n\}$ is the one used in Michel's lower bound [11]. Löding shows that L_n is recognized by a deterministic Muller automaton with only n^2 states, whereas an equivalent deterministic Rabin automaton needs $2^{\Omega(n \log n)}$ states [9]. Yet, these Muller automata also require an index exponential in the number of states.

It is thus open whether the explicit Muller condition can allow for significantly smaller automata than equivalent Rabin and Streett automata. We answer it positively, providing families of deterministic Muller automata of size in $O(n)$, for which we prove that equivalent deterministic Rabin and Streett automata have at least $2^{\Omega(n)}$ states (Theorems 4 and 5). We leave open a gap between this lower bound and the $2^{O(n \log n)}$ upper bound of the State Appearance Records construction.

■ **Table 1** The size blowup involved in the translations of Muller automata to Büchi, Parity, Rabin, and Streett automata.

From	To	Deterministic			Non-Deterministic			
		P	R	S	B	P	R	S
Det. Muller		$2^{O(n \log n)}$			$\Theta(n^3)$		$O(n^3)$	$\Theta(n^2)$
		$2^{\Omega(n)}$						
Non-Det. Muller		Prop. 3 Thms. 4,5			Prop. 6 Thm. 10	Prop. 6 Thm. 9	Prop. 7 Thm. 8	
		$2^{O(n^3 \log n^3)}$						
		$2^{\Omega(n)}$ Prop. 1,2						

As for the translation of Muller automata to nondeterministic automata of the other types, there is a known construction that involves an $O(n^3)$ size blowup in the translation to Büchi, parity, and Rabin automata, which can be improved to $O(n^2)$ for the translation to Streett. We provide corresponding lower bounds, tight for the translations to Büchi, parity, and Streett, and with a gap between $\Omega(n^2)$ and $O(n^3)$ for the translation to Rabin (Theorems 8-10).

Regarding the translations to Muller automata, Safra shows that the translation of deterministic Büchi to nondeterministic Muller automata involves an exponential size blowup, and of nondeterministic Büchi to deterministic Muller a doubly exponential blowup [17]. Safra does include the index in the automaton size, however uses in the latter lower bound an alphabet of length exponential in the number of states.

We strengthen Safra's lower bounds, by providing families of languages over a fixed alphabet and by showing that the size blowup stems directly from the structure of the translated automata, regardless of the acceptance condition – our languages are recognized by looping automata, which are Büchi automata all of whose states are accepting (Theorems 12 and 16).

For the translation of deterministic automata as well as for the translation to nondeterministic Muller automata, the bounds are tight for all types. Considering the translations of nondeterministic automata to deterministic Muller automata, the bounds are tight for looping, weak, and co-Büchi automata, there is a gap between $2^{2^{\Omega(n)}}$ and $2^{2^{O(n \log n)}}$ for Büchi, and a gap between $2^{2^{\Omega(n)}}$ and $2^{2^{O(n^2 \log n^2)}}$ for parity, Rabin, and Streett.

The translation blowups are summarized in Tables 1 and 2. Table 1 only includes types to which Muller automata can always be translated, while Table 2 includes additional types, as they all can be translated to Muller. Theorems 4-5 and 8-10 are new, while Theorems 12 and 16 strengthen known results. On the technical level, Theorem 4 has the most involved proof, Theorem 5 is proved analogously, and the proofs of Theorems 8 and 9 provide two different lower-bound techniques, on top of which the proof of Theorem 10 is built. Theorems 12 and 16 strengthen lower-bound results that were known for Büchi automata over a linear or an exponential alphabet to corresponding results for looping automata over a fixed alphabet.

12:4 On the (In)Succinctness of Muller Automata

■ **Table 2** The size blowup involved in the translations to Muller automata. “All” stands for the automata types as abbreviated in the table by their first letter, namely Looping, Weak, Co-Büchi, Büchi, Parity, Rabin, and Streett.

From		To	Det. Muller	Non-Det. Muller
Det.	All		$2^{\Theta(n)}$ Prop. 11, Thm. 12	
Non-Det.	L		$2^{2^{\Theta(n)}}$ Prop. 13, Thm. 16	
	W			
	C			
	B		$2^{2^{O(n \log n)}}$	$2^{2^{\Omega(n)}}$ Prop. 11 Thm. 12
	P		$2^{2^{O(n^2 \log n^2)}}$ Prop. 14,15 Thm. 16	
	R			
	S			

2 Preliminaries

Given a finite alphabet Σ , a *word* over Σ is a (possibly infinite) sequence $w = w(0) \cdot w(1) \cdots$ of letters in Σ .

An *automaton* is a tuple $\mathcal{A} = \langle \Sigma, Q, \delta, Q_0, \alpha \rangle$, where Σ is the input alphabet, Q is a finite set of states, $\delta : Q \times \Sigma \rightarrow 2^Q$ is a transition function, $Q_0 \subseteq Q$ is a set of initial states, and α is an acceptance condition. The automaton \mathcal{A} may have several initial states and the transition function may specify many possible transitions for each state and letter, and hence we say that \mathcal{A} is *nondeterministic*. In the case where $|Q_0| = 1$ and for every $q \in Q$ and $\sigma \in \Sigma$, we have $|\delta(q, \sigma)| \leq 1$, we say that \mathcal{A} is *deterministic*. For a state q of \mathcal{A} , we denote by \mathcal{A}^q the automaton that is derived from \mathcal{A} by changing the set of initial states to $\{q\}$.

A *run*, or a *path*, $r = r(0), r(1), \dots$ of \mathcal{A} on $w = w(0) \cdot w(1) \cdots \in \Sigma^\omega$ is an infinite sequence of states such that $r(0) \in Q_0$, and for every $i \geq 0$, we have $r(i+1) \in \delta(r(i), w(i))$.

Acceptance is defined with respect to the set $\text{inf}(r)$ of states that the run r visits infinitely often. Formally, $\text{inf}(r) = \{q \in Q \mid \text{for infinitely many } i \in \mathbb{N}, \text{ we have } r(i) = q\}$. As Q is finite, it is guaranteed that $\text{inf}(r) \neq \emptyset$. The run r is *accepting* iff the set $\text{inf}(r)$ satisfies the acceptance condition α , and otherwise it is *rejecting*.

Several acceptance conditions are studied in the literature; the main ones are:

- *Büchi*, where $\alpha \subseteq Q$, and r is accepting iff $\text{inf}(r) \cap \alpha \neq \emptyset$.
- *co-Büchi*, where $\alpha \subseteq Q$, and r is accepting iff $\text{inf}(r) \cap \alpha = \emptyset$.
- *weak* is a special case of the Büchi condition, where every strongly connected component of the automaton is either contained in α or disjoint to α ; that is, no strongly connected component has a state in α and some other state not in α .
- *looping* is a special case of the Büchi condition, where $\alpha = Q$, meaning that all states are accepting.
- *parity*, where $\alpha = \{\alpha_1, \alpha_2, \dots, \alpha_{2k}\}$ with $\alpha_1 \subset \alpha_2 \subset \dots \subset \alpha_{2k} = Q$, and r is accepting if the minimal index i for which $\text{inf}(r) \cap \alpha_i \neq \emptyset$ is even.
- *Rabin*, where $\alpha = \{\langle \alpha_1, \beta_1 \rangle, \langle \alpha_2, \beta_2 \rangle, \dots, \langle \alpha_k, \beta_k \rangle\}$, with $\alpha_i, \beta_i \subseteq Q$ and r is accepting iff for some $1 \leq i \leq k$, we have $\text{inf}(r) \cap \alpha_i \neq \emptyset$ and $\text{inf}(r) \cap \beta_i = \emptyset$.

- *Streett*, where $\alpha = \{\langle \beta_1, \alpha_1 \rangle, \langle \beta_2, \alpha_2 \rangle, \dots, \langle \beta_k, \alpha_k \rangle\}$, with $\beta_i, \alpha_i \subseteq Q$ and r is accepting iff for all $1 \leq i \leq k$, we have $\text{inf}(r) \cap \beta_i = \emptyset$ or $\text{inf}(r) \cap \alpha_i \neq \emptyset$.
- *Muller*, where $\alpha = \{\alpha_1, \alpha_2, \dots, \alpha_k\}$, with $\alpha_i \subseteq Q$ and r is accepting iff for some $1 \leq i \leq k$, we have $\text{inf}(r) = \alpha_i$.

Notice that Büchi and co-Büchi are special cases of the parity condition, which is in turn a special case of both the Rabin and Streett conditions.

The number of sets in the parity and Muller acceptance conditions or pairs in the Rabin and Streett acceptance conditions is called the *index* of the automaton. For looping, weak, co-Büchi, and Büchi automata, the index is 1.

The *size* of an automaton is the maximum size of its elements; more precisely, it is the maximum of the alphabet length, the number of states, the number of transitions, and the index.

An automaton accepts a word if it has an accepting run on it. The language of an automaton \mathcal{A} , denoted by $L(\mathcal{A})$, is the set of words that \mathcal{A} accepts. We also say that \mathcal{A} *recognizes* the language $L(\mathcal{A})$. Two automata, \mathcal{A} and \mathcal{A}' , are *equivalent* iff $L(\mathcal{A}) = L(\mathcal{A}')$.

For a finite path $C = q_1 q_2 \dots q_n$, we say that C is accepting (resp., rejecting) if the infinite path C^ω is accepting (resp., rejecting). Notice that the union of two Rabin-rejecting (finite) paths is Rabin-rejecting, and of two Streett-accepting (finite) paths is Streett-accepting.

The *class* of an automaton characterizes its branching mode (deterministic or nondeterministic) and its acceptance condition. In the more technical paragraphs, we shall denote the different classes of automata by three letter acronyms in $\{D, N\} \times \{L, W, B, C, P, R, S, M\} \times \{W\}$. The first letter stands for the branching mode of the automaton (deterministic or nondeterministic); the second for the acceptance-condition (looping, weak, Büchi, co-Büchi, parity, Rabin, Streett, or Muller); and the third indicates that the automaton runs on words. For example, DBW stands for deterministic Büchi automata on words.

Büchi, parity, Rabin, Streett, and Muller automata have the same expressive power, recognizing all ω -regular languages. Looping, weak, and co-Büchi automata, as well as deterministic Büchi automata, are less expressive.

3 From Muller

We start with the translation of nondeterministic Muller automata to deterministic automata of the other types, for which there are known singly-exponential constructions. We continue, in Section 3.2, with the translation of deterministic Muller to deterministic automata of the other types, for which we answer positively the open question of whether an exponential size blowup is inevitable. In Section 3.3, we provide lower bounds for the known polynomial translations of Muller automata to nondeterministic automata of the other types.

3.1 From Nondeterministic Muller To Deterministic Types

The translation of Muller automata to deterministic automata of the other types involves a singly exponential size blowup. A possible construction is to first translate the Muller automaton into a Büchi automaton, involving an $O(n^3)$ size blowup (Prop. 6), and then determinize it into a Rabin or parity automaton of size in $2^{O(n^3 \log n^3)}$ [17, 15]. An alternative approach is to translate the NMW to a nondeterministic Streett automaton, which only involves a $O(n^2)$ blowup (Prop. 7), and then determinize the latter. Yet, as the determinization of Streett automata is more involved [18, 15], the overall size blowup is not improved.

► **Proposition 1** ([17, 15]). *Muller automata of size n can be translated to parity, Rabin, and Streett automata of size in $2^{O(n^3 \log n^3)}$.*

An exponential lower bound for the determinization of all automata types is trivial, by reduction to the case of finite words.

► **Proposition 2.** *Determinizing all automata types involves at least an exponential size blowup.*

It may be interesting to close the gap between the trivial $2^{\Omega(n)}$ lower bound and the $2^{O(n^3 \log n^3)}$ upper bound.

3.2 From Deterministic Muller To Deterministic Types

Translating deterministic Muller automata to deterministic parity, Rabin, and Streett automata can be done by the State Appearance Records (SAR) construction [6]. The translation of a DMW with l states results in a DPW with up to $2^{O(l \log l)}$ states, regardless of the DMW's index.

► **Proposition 3** ([6]). *Deterministic Muller automata of size n can be translated to deterministic parity, Rabin, and Streett automata of size in $2^{O(n \log n)}$.*

We show below that an exponential size blowup in the translation to parity, Rabin, and Streett automata is inevitable. The proofs borrow ideas from lower bound proofs in [9] and [1], building on the property of the Rabin (resp., Streett) acceptance condition, according to which the union of two rejecting (resp., accepting) cycles is rejecting (resp., accepting).

We start with the translation to Rabin automata. Consider the family of DMWs $\{\mathcal{D}_n\}$, as depicted in Figure 1. The DMW \mathcal{D}_n accepts words over the “alphabet” $[-n..n]$, in which the “letters” that appear infinitely often are exactly all of the “letters” between $-i$ and i , for some $i \in [1..n]$. Technically, a “letter” i is the finite word $a^i \#$ and $-i$ is $b^i \#$.

Let $w_{i,j}$, for $i < j \in [-n..n]$, be words in which exactly all of the letters in $[i..j]$ appear infinitely often. We show that a DRW \mathcal{A} equivalent to \mathcal{D}_n has at least 2^{n-1} states, by proving that a run r of \mathcal{A} on the word $w_{-(i+1),i+1}$ visits at least twice the number of states that a run r_i of \mathcal{A} on $w_{-i,i}$ visits.

The proof idea is intuitively as follows. Let r' and r'' be the runs of \mathcal{A} on $w_{-i,i+1}$ and $w_{-(i+1),i}$, respectively. Then: I) The runs r' and r'' contain the run r_i , thus visit at least as many states as r_i . II) By the definition of \mathcal{D}_n , both r' and r'' are rejecting. III) According to the property of the Rabin condition, the union of r' and r'' is rejecting. IV) The runs r' and r'' visit infinitely often disjoint sets of states – if they had a common state, their union would have been a rejecting run of \mathcal{A} on $w_{-(i+1),i+1}$, contradicting its acceptance by \mathcal{D}_n . V) The run r contains the runs r' and r'' , thus visit at least twice the number of states that r_i visits.

► **Theorem 4.** *The translation of deterministic Muller automata to deterministic Rabin automata involves a size blowup of at least $2^{\Omega(n)}$. In particular, there is a family $\{\mathcal{D}_n\}_{n \geq 1}$ of DMWs with $2n+1$ states, $4n$ transitions, and n accepting sets, for which equivalent DRWs have at least 2^{n-1} states.*

Proof. Consider the family $\{\mathcal{D}_n\}$ of DMWs over $\Sigma = \{a, b, \#\}$, as depicted in Figure 1, and let \mathcal{R} be a DRW equivalent to \mathcal{D}_n .

For readability, we define for every $i \in [1..n]$, $\widehat{i} = a^i \#$ and $\widehat{-i} = b^i \#$. Then, the language of \mathcal{D}_n can be defined over the finite words \widehat{j} , for $j \in [-n..-1] \cup [1..n]$. For simplifying the expressions, we will speak of \widehat{j} , for $j \in [-n..n]$, while considering $\widehat{0}$ to be the empty word.

The Deterministic Muller automata \mathcal{D}_n , \mathcal{D}'_n , and \mathcal{D}''_n .

The acceptance conditions:

\mathcal{D}_n : The sets Q_i , for $i \in [1..n]$, where $Q_i = \{q_j \mid j \in [-i..i]\}$

\mathcal{D}'_n : The sets Q'_i and Q''_i , for $i \in [1..n]$, where
 $Q'_i = \{q_j \mid j \in [-i..i-1]\}$ and $Q''_i = \{q_j \mid j \in [-(i-1)..i]\}$

\mathcal{D}''_n : The sets P_i , for $i \in [0..n]$, where $P_i = \{q_j \mid j \in [-i..n-i]\}$

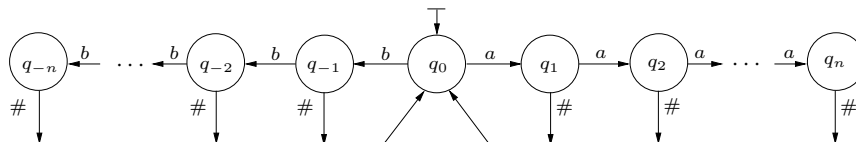

■ **Figure 1** Deterministic Muller automata \mathcal{D}_n , \mathcal{D}'_n , and \mathcal{D}''_n of size in $O(n)$. For \mathcal{D}_n and \mathcal{D}'_n , equivalent deterministic Rabin and Streett automata, respectively, have at least 2^{n-1} states. For \mathcal{D}''_n , equivalent nondeterministic Streett automata have at least $n^2/2$ states.

We say that a state q of \mathcal{R} is *significant* if it is reachable after reading a $\#$ (namely after an \widehat{i} subword), and from which the automaton can accept some word. Observe that for every significant state q , we have $L(\mathcal{R}^q) = L(\mathcal{R})$, namely the automaton that we get from \mathcal{R} by changing the initial state to q is equivalent to \mathcal{R} (and to \mathcal{D}_n). This is the case since every accepting run of \mathcal{D}_n returns to the initial state after reading a $\#$.

We prove by induction on h , for $h \in [1..n]$, the following claim, from which the theorem immediately follows: For every significant state q of \mathcal{R} , there exist finite words $u, v \in \Sigma^*$, such that:

- (i) For every $j \in [-n..n]$, \widehat{j} appears in u at its start position or after a $\#$ iff $j \in [-h..h]$.
The same w.r.t. v .
- (ii) The run of \mathcal{R}^q on u reaches some significant state p .
- (iii) The run of \mathcal{R}^p on v returns to p , while visiting at least 2^{h-1} different significant states.

The base case, for $h = 1$, is trivial, as it means a cycle of size at least 1.

In the induction step, we assume the induction hypothesis for h and prove it for $h+1$. We do it in two phases.

Phase 1. We first show that we can add $\widehat{h+1}$ as well as $\widehat{-(h+1)}$ to u and v , while keeping the induction hypothesis. Formally, we claim that for every significant state q of \mathcal{R} , there exist finite words $u', v', u'', v'' \in \Sigma^*$, such that:

- (i') For every $j \in [-n..n]$, \widehat{j} appears in u' at its start position or after a $\#$ iff $j \in [-h..h+1]$.
The same w.r.t. v' .
- (ii') The run of \mathcal{R}^q on u' reaches some significant state p' .
- (iii') The run of $\mathcal{R}^{p'}$ on v' returns to p' , while visiting at least 2^{h-1} different significant states.
- (i'') For every $j \in [-n..n]$, \widehat{j} appears in u'' at its start position or after a $\#$ iff $j \in [-(h+1)..h]$.
The same w.r.t. v'' .
- (ii'') The run of \mathcal{R}^q on u'' reaches some significant state p'' .
- (iii'') The run of $\mathcal{R}^{p''}$ on v'' returns to p'' , while visiting at least 2^{h-1} different significant states.

We prove below the claim w.r.t. u' and v' , while the case of u'' and v'' is completely analogous.

Consider a significant state q , which we also denote by p_0 , and let u_0 and v_0 be finite words that satisfy requirements i-iii of the induction hypothesis w.r.t. p_0 . We define the

finite word $z_0 = u_0 v_0 \widehat{h+1}$. Notice that a \widehat{j} -word appears in z_0 iff $j \in [-h..h+1]$. Let p_1 be the significant state that \mathcal{R}^{p_0} reaches when reading z_0 .

We iteratively continue as above, taking words u_1, v_1 , and z_1 w.r.t p_1 , etc., until reaching an iteration i , for which there is $k < i$, such that $p_i = p_k$.

Observe that the words $u' = z_0 z_1 \cdots z_{k-1}$ and $v' = z_k z_{k+1} \cdots z_{i-1}$ satisfy the requirements i'-iii': they contain a \widehat{j} -word iff $j \in [-h..h+1]$; the run of \mathcal{R}^q on u' reaches the significant state p_k ; and the run of \mathcal{R}^{p_k} on v' returns to p_k , while visiting at least 2^{h-1} different significant states. The latter holds, since the run of \mathcal{R}^{p_k} on z_k already visits at least 2^{h-1} different significant states.

Phase 2. We continue with showing that the induction claim holds for $h+1$.

Consider a significant state q , denoted by p_0 , and let u'_0 and v'_0 be finite words that satisfy requirements i'-iii' w.r.t. q . Let p'_1 be the significant state that \mathcal{R}^{p_0} reaches when reading $u'_0 v'_0$. Now, let u''_0 and v''_0 be finite words that satisfy requirements i''-iii'' w.r.t. p'_1 . Let p_1 be the significant state that $\mathcal{R}^{p'_1}$ reaches when reading $u''_0 v''_0$. We define the finite word $z_0 = u'_0 v'_0 u''_0 v''_0$. Notice that a \widehat{j} -word appears in z_0 iff $j \in [-(h+1)..h+1]$.

We iteratively continue as above, defining words z_i , until reaching an iteration i , for which there is $k < i$, such that $p_i = p_k$.

We claim that the words $u = z_0 z_1 \cdots z_{k-1}$ and $v = z_k z_{k+1} \cdots z_{i-1}$ satisfy requirements i-iii w.r.t. q and $h+1$. The first two requirements are simply satisfied by the definition of u and v . As for the third requirement, we claim that when \mathcal{R}^{p_k} runs on v , it visits disjoint set of states when reading v'_k and v''_k . This will provide the required 2^h different significant states, as \mathcal{R}^{p_k} visits at least 2^{h-1} different significant states when reading each of v'_k and v''_k .

Indeed, assume, by way of contradiction, that \mathcal{R}^{p_k} visits some state s both when reading v'_k and when reading v''_k . Let l' and r' be the parts of v'_k that \mathcal{R}^{p_k} reads before and after reaching s , respectively, and l'' and r'' the analogous parts of v''_k . Now, define the infinite words $m' = u'_k (l' r')^\omega$, $m'' = u'_k l' (r'' l'')^\omega$, and $m = u'_k (l' r'' l'' r')^\omega$.

Observe that since the language of \mathcal{R}^{p_k} is the same as of \mathcal{D}_n , both m' and m'' are not accepted by \mathcal{R}^{p_k} , while m is accepted by \mathcal{R}^{p_k} . However, the set of states that are visited infinitely often in the run of \mathcal{R}^{p_k} on m is the union of the sets of states that appear infinitely often in the runs of \mathcal{R}^{p_k} on m' and m'' . Hence, since the union of two Rabin-rejecting paths is Rabin-rejecting, the run of \mathcal{R}^{p_k} on m should be rejecting, leading to a contradiction. ◀

Considering the translation of deterministic Muller to deterministic Streett automata, the family $\{\mathcal{D}_n\}_{n \geq 1}$ of DMWs of Figure 1 does not provide the required lower bound. Indeed, there is a DSW equivalent to \mathcal{D}_n over the structure of \mathcal{D}_n and having $2n$ Street acceptance pairs – for every $i \in [1..n]$, the pairs $\langle \{q_i\}, \{q_{-i}\} \rangle$ and $\langle \{q_{-i}\}, \{q_i\} \rangle$.

Yet, an exponential blowup can be shown by changing the acceptance condition of \mathcal{D}_n , such that the combination of two accepting cycles yields a rejecting cycle, as is done in the Muller automata \mathcal{D}'_n of Figure 1.

► **Theorem 5.** *The translation of deterministic Muller automata to deterministic Streett automata involves a size blowup of at least $2^{\Omega(n)}$. In particular, there is a family $\{\mathcal{D}'_n\}_{n \geq 1}$ of DMWs with $2n+1$ states, $4n$ transitions, and $2n$ accepting sets, for which equivalent DSWs have at least 2^{n-1} states.*

Proof. The proof is completely analogous to the proof of Theorem 4, except for combining two accepting cycles rather than two rejecting ones; that is, the only change to the proof of Theorem 4 is in the last paragraph, which should be as follows.

Observe that since the language of \mathcal{R}^{p_k} is the same as of \mathcal{D}'_n , both m' and m'' are accepted by \mathcal{R}^{p_k} , while m is not accepted by \mathcal{R}^{p_k} . However, the set of states that are visited infinitely often in the run of \mathcal{R}^{p_k} on m is the union of the sets of states that appear infinitely often

in the runs of \mathcal{R}^{pk} on m' and m'' . Hence, since the union of two Streett-accepting paths is Streett-rejecting, the run of \mathcal{R}^{pk} on m should be accepting, leading to a contradiction. ◀

3.3 From Muller To Nondeterministic Types

Our bounds for the translations of Muller automata to nondeterministic automata of the other types are the same when translating deterministic and when translating nondeterministic Muller automata. We show the upper bounds with respect to nondeterministic Muller automata, obviously holding also for deterministic automata, and the lower bounds with respect to deterministic Muller automata, obviously holding also for nondeterministic automata.

There is a well known translation of Muller automata to Büchi automata, involving a size blowup of $O(n^3)$, which can be improved to $O(n^2)$ when the target automaton is Streett.

We show a tight $\Omega(n^2)$ lower bound for the translation to Streett, and an $\Omega(n^2)$ lower bound for the translation to Rabin. The latter already holds for a Muller automaton with index 1. Combining the techniques of these two lower bounds, we show a tight $\Omega(n^3)$ lower bound for the translation to Büchi and parity automata.

3.3.1 Upper Bounds

The idea in translating a Muller automaton \mathcal{A} with index k to a Büchi automaton \mathcal{B} is to first “guess” which set S of states, out of the k possibilities, will be visited infinitely often. This contributes the ‘first’ n of the $O(n^3)$ construction. The second step is to “guess” when the states out of S are no longer visited. This step only doubles the automaton size. Then, having up to n states in S , \mathcal{B} traverses n copies of the restriction of \mathcal{A} to the states of S , for ensuring that all of the n states are visited infinitely often. This contributes the two other n 's of the $O(n^3)$ construction.

► **Proposition 6.** *Muller automata of size n can be translated to Büchi automata of size in $O(n^3)$. In particular, for every NMW with l states, m transitions, and index k , there exists an equivalent NBW with kl^2 states and $k(l+1)m$ transitions.*

A translation to Streett automata is possible with only an $O(n^2)$ size blowup, using the Streett condition to enforce all of the relevant n states to be visited infinitely often.

► **Proposition 7.** *Muller automata of size n can be translated to Streett automata of size in $O(n^2)$. In particular, for every NMW with l states, m transitions, and index k , there exists an equivalent NSW with $2kl$ states, $3km$ transitions, and index kl .*

3.3.2 Lower Bounds

When we considered in Section 3.2 the translations to deterministic automata, we showed a lower bound on the number of states that a run r on some word w must visit, by adding up the already achieved lower bounds on sub-runs of r on subwords of w (Theorems 4 and 5). This technique cannot work when considering the translations to a nondeterministic automaton, as the automaton may have many runs on w , not necessarily containing the “best” runs on w 's subwords.

For achieving a lower bound on the number of states in a nondeterministic Streett automaton \mathcal{A} , we define a new family $\{\mathcal{D}_n''\}$ of DMWs, as depicted in Figure 1, and concentrate on the accepting runs of \mathcal{A} . The DMW \mathcal{D}_n'' accepts words over the “alphabet” $[-n..n]$, in which the “letters” that appear infinitely often are exactly all of the “letters” between $-i$ and $n-i$, for some $i \in [1..n]$. Technically, a “letter” i is the finite word $a^i\#$ and $-i$ is $b^i\#$.

12:10 On the (In)Succinctness of Muller Automata

For getting the $\Omega(n^2)$ lower bound, we first show that every accepting run of \mathcal{A} must visit infinitely often at least n different states. The reason is that \mathcal{A} needs to count n consecutive a 's or b 's, as otherwise it will also accept illegal words with too many consecutive a 's or b 's. Next, we show that accepting runs on different words visit infinitely often disjoint sets of states. The reason stems from a property of the Streett condition, according to which the combination of two accepting cycles is accepting – if the runs had a common state, their combination would have accepted the combined word, which is rejected by \mathcal{D}''_n .

► **Theorem 8.** *The translation of deterministic Muller automata to nondeterministic Streett automata involves a size blowup of at least $\Omega(n^2)$. In particular, there is a family $\{\mathcal{D}''_n\}_{n \geq 1}$ of DMWs with $2n+1$ states, $4n$ transitions, and $n+1$ accepting sets, for which equivalent NSWs have at least $n^2/2$ states.*

Proof. Consider the family $\{\mathcal{D}''_n\}_{n \geq 1}$ of DMWs depicted in Figure 1, and let \mathcal{A} be an NSW equivalent to \mathcal{D}''_n .

For every $i \in [0..n]$, define the word $w_i = (b^i \# a^{n-i} \#)^\omega$, which is accepted by \mathcal{A} , and let r_i be an accepting run of \mathcal{A} on w_i . (For $i = 0$ and $i = n$, the first and last $\#$, respectively, are omitted from w_i 's period.)

For showing that \mathcal{A} has at least $n^2/2$ states, we will prove that I) for every $i \in [0..n]$, the run r_i visits infinitely often at least i different states, and II) for every $i \neq j \in [0..n]$, the states that r_i and r_j visit infinitely often are disjoint. (This will imply $\sum_{i=0}^n i = n(n+1)/2$ states.)

(I) Assume toward contradiction that for some $i \in [0..n]$, the run r_i visits less than i different states infinitely often. Then r_i makes a cycle c of length $m < i$ while reading only b 's. Let q be a state that r_i visits infinitely often along the cycle c , and let p be the first position of w_i in which r_i visits q . Define the word w'_i that is derived from w_i by adding the finite word b^{nm} in position p . Observe that \mathcal{A} accepts w'_i by a the run r' that starts like r_i , makes n times the cycle c in position p , and then continues like r_i . However, w'_i is not accepted by \mathcal{D}''_n , leading to a contradiction.

(II) Assume toward contradiction that for some $i < j \in [0..n]$, both r_i and r_j visit some state s infinitely often. Let p and p' be positions of w_i in which r_i visits s , and between which r_i visits at least n times all the states that it will visit infinitely often. Let u be the subword of w_i between positions p and p' . Notice that w_i must contain both b^i and a^{n-i} .

Now, let w be the word that is derived from w_j by adding u in every position in which r_j visits s . Consider the run r of \mathcal{A} on w that follows r_j , while making extra cycles from s back to itself in every position that u was added to w . Notice that the states that r visits infinitely often are the union of the states that r_i and r_j visit infinitely often. Hence, due to the property of the Streett condition that the union of two accepting cycles is accepting, we have that r is accepting. Yet since w contains both b^j and a^{n-i} infinitely often, it is not accepted by \mathcal{D}''_n , leading to a contradiction. ◀

The proof of Theorem 8 is based on the fact that the union of two Streett accepting cycles is accepting. This does not hold for the Rabin condition, and therefore a different technique is needed for a lower bound in the translation to a nondeterministic Rabin automaton \mathcal{A} .

We should somehow take advantage of the dual property of the Rabin condition, according to which the union of two Rabin rejecting cycles is rejecting. Yet, there is no use in combining two rejecting runs, as \mathcal{A} need not use their rejecting combination on a word that should be accepted, but rather use a different run that does accept it.

Our approach will be to construct a word w on which an accepting run r of \mathcal{A} must visit at least n^2 different states, or else we can split r into rejecting runs whose union, which is

The deterministic Muller automata \mathcal{M}_n and \mathcal{M}'_n

The states:

\mathcal{M}_n : Only the right side, namely $\{p_i, q_i \mid i \geq 0\}$

\mathcal{M}'_n : All states

The acceptance conditions:

\mathcal{M}_n : A single set with all its states, namely $\{p_i, q_i \mid i \geq 0\}$

\mathcal{M}'_n : The sets Q_i , for $i \in [0..n]$, where $Q_i = \{q_0\} \cup \{p_j, q_j \mid j \in [-i..n-i] \setminus \{0\}\}$

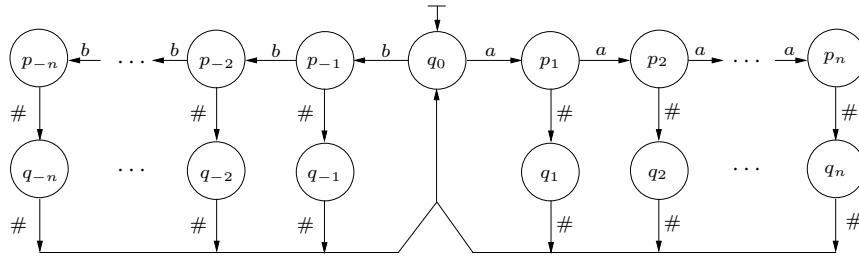

Figure 2 The Deterministic Muller automata \mathcal{M}_n and \mathcal{M}'_n of size in $O(n)$, for which equivalent nondeterministic Rabin and parity automata have, respectively, at least $n^2/2$ and $n^3/2$ states.

r , is also rejecting. For constructing such a word w , we need a different family of DMWs, in which a state q_i can be visited without visiting q_{i-1} . We define such a family of DMWs $\{\mathcal{M}_n\}$ in Figure 2.

Theorem 9. *The translation of deterministic Muller automata, even with index 1, to nondeterministic Rabin automata involves a size blowup of at least $\Omega(n^2)$. In particular, there is a family $\{\mathcal{M}_n\}_{n \geq 1}$ of DMWs with $2n+1$ states, $3n$ transitions, and a single accepting set, for which equivalent NRWs have at least $n^2/2$ states.*

Proof. Consider the family $\{\mathcal{M}_n\}_{n \geq 1}$ of DMWs depicted in Figure 2, and let \mathcal{A} be an NRW equivalent to \mathcal{M}_n .

Define the finite word $u = (a\#\#aa\#\#\dots a^n\#\#)$, and the infinite word $w = u^\omega$. Notice that the length of u is bigger than $n^2/2$ and that \mathcal{A} accepts w . We will show that an accepting run r of \mathcal{A} on w must visit infinitely often at least $n^2/2$ different states, from which the required result immediately follows.

Assume toward contradiction that r visits the set S of states infinitely often, where $|S| < n^2/2$. Consider a simple cycle C of \mathcal{A} along states in S . We claim that C is a rejecting cycle.

Indeed, consider a state q in C , let x be a finite word on which \mathcal{A} can reach q , and let y be a finite word on which \mathcal{A}^q can reach back q along C . The word y can either or not include the letter $\#$. If y does not include $\#$, then \mathcal{M}_n does not accept the word yx^ω , since it has the infix a^{n+1} , on which \mathcal{M}_n cannot run. If y does include $\#$, then \mathcal{M}_n also does not accept the word yx^ω , since the subword a^n does not appear infinitely often in it. Hence, \mathcal{M}_n does not accept yx^ω , implying that C is a rejecting cycle, as otherwise \mathcal{A} would have accepted yx^ω .

Now, S is the union of its simple cycles, and since all of them are rejecting, by the property of the Rabin condition, so is S . Hence, the run r is rejecting. Contradiction. \blacktriangleleft

Parity automata are a special case of both Rabin and Streett automata. This suggests that we might be able to apply the lower bound techniques of both Theorem 8 and Theorem 9. Indeed, in Theorem 10 we show an $\Omega(n^3)$ lower bound for the translation of the deterministic

Muller automata $\{\mathcal{M}_n\}$ of Figure 2 to nondeterministic parity automata. We use the technique of Theorem 8 for showing that there are n different runs that visit disjoint states, and the technique of Theorem 9 for showing that each such run visits at least $n^2/2$ different states.

► **Theorem 10.** *The translation of deterministic Muller automata to nondeterministic parity automata involves a size blowup of at least $\Omega(n^3)$. In particular, there is a family $\{\mathcal{M}_n\}_{n \geq 1}$ of DMWs with $4n+1$ states, $6n$ transitions, and $n+1$ accepting sets, for which equivalent NRWs have at least $n^3/2$ states.*

Proof. Consider the family $\{\mathcal{M}_n\}_{n \geq 1}$ of DMWs depicted in Figure 2, and let \mathcal{A} be an NPW equivalent to \mathcal{M}_n .

For every $i \in [0..n]$, define the finite word $u_i = (b\#\#bb\#\#\cdots b^i\#\#a\#\#aa\#\#\cdots a^{n-i}\#\#)$, and the infinite word $w = u_i^\omega$. (For $i = 0$ and $i = n$, the first and last $\#\#$, respectively, are omitted from u_i .) Notice that the length of u_i is bigger than $n^2/2$ and that \mathcal{A} accepts w_i .

Analogously to the arguments in Theorem 9, for every $i \in [0..n]$, an accepting run r_i of \mathcal{A} on w_i must visit infinitely often at least $n^2/2$ different states. Analogously to the arguments in Theorem 8, for every $i \neq j \in [0..n]$, accepting runs r_i and r_j of \mathcal{A} on w_i and w_j , respectively, do not have any state in common. Hence, there are at least $n(n^2/2) = n^3/2$ states in \mathcal{A} . ◀

4 To Muller

We show that an exponential size blowup in the translations to nondeterministic Muller automata is inevitable, even when the source automaton is deterministic. Furthermore, translating nondeterministic automata to deterministic Muller automata, one cannot avoid the aforementioned exponential blowup, getting a doubly exponential size blowup.

The inevitable size blowups stem directly from the structure of the source automata, regardless of the alphabet and of the accepting condition – they already hold for looping automata, whole of whose states are accepting, over a fixed alphabet of three letters.

Exponential upper bounds are immediate: every (deterministic) automaton of the considered types has an equivalent (deterministic) Muller automaton over the same states and transitions. Thus, the Muller index can only be up to exponentially larger than the size of the input automaton. Considering the translations of nondeterministic types to deterministic Muller automata, the bound is tight for looping, weak, and co-Büchi automata, there is a gap between $2^{2^{\Omega(n)}}$ and $2^{2^{O(n \log n)}}$ for Büchi, and a gap between $2^{2^{\Omega(n)}}$ and $2^{2^{O(n^2 \log n^2)}}$ for parity, Rabin, and Streett.

► **Proposition 11.** *The translation of all (deterministic) automata to (deterministic) Muller automata involves a size blowup of up to $2^{O(n)}$. (All = Looping, weak, co-Büchi, Büchi, parity, Rabin, and Streett.)*

4.1 To Nondeterministic Muller

An exponential size blowup in the translation of deterministic Büchi automata to nondeterministic Muller automata is shown in [17]. They provide¹ a family $\{L_n\}$ of languages

¹ In [17], there is a statement of the lower bound without providing the explicit languages and Büchi automata. They refer to a lemma about the complementation of Muller automata, and claim that

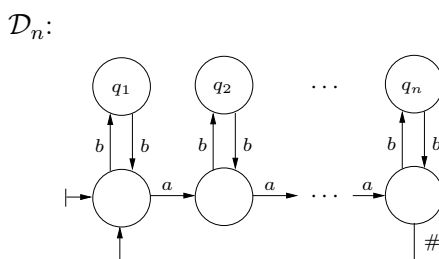

■ **Figure 3** Deterministic looping automata of size in $O(n)$, for which equivalent nondeterministic Muller automata need an index of at least 2^n .

over alphabets of length $2n$, such that L_n is recognized by a Büchi automaton with $n + 2$ states and $n^2 + n + 2$ transitions, while equivalent Muller automata have an index of at least 2^n .

We improve the result by providing a different family $\{L'_n\}$ of languages over a fixed alphabet, such that L'_n is recognized by a looping automaton with $2n$ states and $3n$ transitions, as depicted in Figure 3, while equivalent Muller automata need an index of at least 2^n .

► **Theorem 12.** *The translation of deterministic looping automata to nondeterministic Muller automata involves a size blowup of at least $2^{\Omega(n)}$.*

Proof. For every positive $n \in \mathbb{N}$, consider the DLW \mathcal{D}_n of Figure 3, which we dub \mathcal{D} , and let \mathcal{M} be an NMW equivalent to \mathcal{D} . We denote by L_a the language of words with infinitely many a 's.

We first classify the states of \mathcal{M} according to their connection with the q_i states of \mathcal{D} . Formally, for every $i \in [1..n]$, we define the set S_i of states of \mathcal{M} to include exactly the states s for which $L(\mathcal{M}^s) \cap L(\mathcal{D}^{q_i}) \cap L_a \neq \emptyset$.

Observe that for every $i \in [1..n]$ and finite word u , if \mathcal{M} visits a state $s \in S_i$ after reading u along an accepting run of \mathcal{M} on a word with infinitely many a 's, then $\mathcal{D}(u) = q_i$. This follows from the structure of \mathcal{D} , according to which there is no word $v \in L_a$, such that $v \in L(\mathcal{D}^{q_i}) \cap L(\mathcal{D}^p)$ for $p \neq q_i$. This also implies that the sets S_1, \dots, S_n are mutually disjoint.

We continue with showing that \mathcal{M} 's index must be at least 2^n . For every subset $H \subseteq [1..n]$, there is a word $w_H \in L(\mathcal{D}) \cap L_a$, such that for every $i \in [1..n]$, \mathcal{D} 's run on w_H visits q_i infinitely often iff $q_i \in H$. Now, for every $i \in H$, there must be a state $s \in S_i$ that is visited infinitely often by an accepting run r_H of \mathcal{M} on w_H , as infinitely often $(\mathcal{D}^{q_i}) \cap L_a \neq \emptyset$. Let F_H be an accepting set of \mathcal{M} according to which r_H is accepted.

Assume, by way of contradiction, that there are two subsets $H \neq H'$ such that $F_H = F_{H'}$. Without loss of generality, consider a number $i \in H' \setminus H$. Then, since there is a state $s \in S_i \cap F_{H'}$ and $F_H = F_{H'}$, it follows that s is visited infinitely often in the run r_H of \mathcal{M} on w_H . Thus, \mathcal{D} visits q_i infinitely often in its run over w_H , contradicting the definition of w_H , as $i \notin H$. ◀

analogous languages provide the lower bound. The languages described here in the name of [17] are those assumed to be the analogous ones.

4.2 To Deterministic Muller

Following Theorem 12, the translation of deterministic automata, of all relevant types, to deterministic Muller automata is in $2^{\Theta(n)}$.

We shall look into the translations of nondeterministic automata to deterministic Muller automata. These translations might involve a doubly exponential size blowup, as the determinization process exponentially enlarges the number of states, and the Muller index might be exponential in the latter number of states. This is indeed the case, and the double exponent stems directly from the automaton structure. It already holds for a looping automaton (all of whose states are accepting) over a fixed alphabet.

4.2.1 Upper Bounds

A co-Büchi automaton of size n can be translated to a deterministic Muller automaton with $2^{O(n)}$ states [12], on top of which the index is in $2^{2^{O(n)}}$.

► **Proposition 13.** *Looping, weak, and co-Büchi automata of size n can be translated to deterministic Muller automata of size in $2^{2^{O(n)}}$.*

A Büchi automaton of size n can be translated to a deterministic Muller automaton with $2^{O(n \log n)}$ states [17], on top of which the index is in $2^{2^{O(n \log n)}}$.

► **Proposition 14.** *Büchi automata of size n can be translated to deterministic Muller automata of size in $2^{2^{O(n \log n)}}$.*

Parity and Rabin automata of size n can be translated to a Büchi automaton of size in $O(n^2)$, and then determinized into a Muller automaton. For Streett automata, the above procedure does not work as there is an exponential blowup in the translation of an NSW to an NBW. Yet, one may determinize the Streett automaton directly into a deterministic Muller automaton with $2^{O(n^2 \log n^2)}$ states [18, 15].

► **Proposition 15.** *Parity, Rabin, and Streett automata of size n can be translated to deterministic Muller automata of size in $2^{2^{O(n^2 \log n^2)}}$.*

4.2.2 Lower Bounds

A doubly exponential lower bound is already shown in [17], however it uses a family of Büchi automata over alphabets of length exponential in the number of states. Hence, it is reasonable to view the size of the resulting deterministic Muller automaton as only singly exponential in the size of the original automaton. Safra's languages [17]: For every $n > 0$, let $\mathcal{S}_n = 2^{[1..n]}$ and $\Sigma_n = \mathcal{S}_n \cup [1..n]$, and define the language

$$L_n = \{Y_0 y_0 Y_1 y_1 \dots \mid \text{for all } i, Y_i \in \mathcal{S}_n \text{ and } y_i \in Y_i\}.$$

One can change Safra's languages to use an alphabet of length linear in the number of states, by replacing the subset-letters Y_i with finite strings, separated with a dedicated symbol $\#$. For avoiding the need to count the finite-strings length, these strings will be of an arbitrary length, "encoding" more than the original exponential alphabet. Formally, for every $n > 0$, let $\Sigma_n = \{\#, 1, 2, \dots, n\}$, and define the language

$$L'_n = \{Y_0 \# y_0 \# Y_1 \# y_1 \# \dots \mid \text{for all } i, Y_i \in [1..n]^* \text{ and } y_i \in [1..n] \text{ appears in } Y_i\}.$$

For achieving a $2^{2^{\Omega(n)}}$ lower bound, we further change the above languages, using a fixed alphabet. Except for encoding the linear alphabet by a fixed one, analogously to

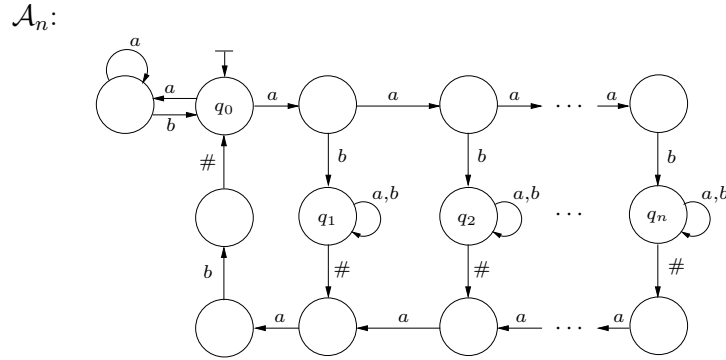

■ **Figure 4** Looping automata of size in $O(n)$, for which equivalent deterministic Muller automata need an index of at least 2^{2^n} .

the way Löding encoded Michel’s language for the Büchi complementation lower bound [9], we simplify the languages, in order to be recognized by looping automata, as depicted in Figure 4.

► **Theorem 16.** *The translation of nondeterministic looping automata to deterministic Muller automata involves a size blowup of at least $2^{2^{\Omega(n)}}$.*

Proof. For every positive $n \in \mathbb{N}$, consider the NLW \mathcal{A}_n of Figure 4, and let \mathcal{M} be a DMW equivalent to \mathcal{A}_n .

In the scope of this proof, we say that the “encoding” of a number $i \in \mathbb{N}$, denoted by \widehat{i} , is the finite string $a^i b$. For example, $\widehat{2} = aab$ and $\widehat{0} = b$.

Consider the set S of states of \mathcal{M} that are reachable after reading a finite word u , such that: i) u ends with $\#$, ii) there is an odd number of $\#$ ’s in u , and iii) there exists an infinite word v , such that $u \cdot v \in L(\mathcal{A}_n)$. Then S has at least 2^n states, corresponding to the subsets of numbers in $[1..n]$ whose encodings appear in the suffix of u from the last even occurrence of a $\#$ onwards, as shown below.

Indeed, assume toward contradiction a state q of \mathcal{M} that is reachable after reading two finite words, u_1 and u_2 , satisfying constraints i-iii above, and whose suffixes include encodings of different numbers in $[1..n]$. Without loss of generality, there is a number $i \in [1..n]$ that is encoded in the suffix of u_1 and not in the suffix of u_2 . Let $v = (\widehat{i} \cdot \#)^\omega$. Since the word $w_1 = u_1 \cdot v \in L(\mathcal{M})$, there is an accepting run of \mathcal{M}^q on v . Thus, \mathcal{M} also accepts the word $w_2 = u_2 \cdot v$, which is not in $L(\mathcal{M})$, leading to contradiction.

We continue with showing that \mathcal{M} ’s index must be at least $2^{2^n - 1}$. Consider the set $H = \{\emptyset, H_1, H_2, \dots, H_{2^n - 1}\}$ of subsets of $[1..n]$. For every $i \in [1..2^n - 1]$, let h_i be the minimal number in H_i , and let \widehat{H}_i be some finite word that is the concatenation of all the words \widehat{j} , such that $j \in H_i$. As shown above, for every element H_i of $H \setminus \{\emptyset\}$, there is a corresponding state s_{H_i} in S . We will show that \mathcal{M} must have an acceptance set for every subset of S .

For every subset $Z = \{H_{i_1}, H_{i_2}, \dots, H_{i_{|Z|}}\}$ of $H \setminus \{\emptyset\}$, consider the infinite word $w_Z = (\widehat{H}_{i_1} \# \widehat{h}_{i_1} \# \widehat{H}_{i_2} \# \widehat{h}_{i_2} \cdots \widehat{H}_{i_{|Z|}} \# \widehat{h}_{i_{|Z|}} \#)^\omega$. By the structure of \mathcal{A}_n , $w_Z \in L(\mathcal{A}_n) = L(\mathcal{M})$. By the definition of the states in S , the accepting run of \mathcal{M} on w_Z visits a state s_x of S infinitely often if and only if $x \in Z$. Hence, \mathcal{M} has a different acceptance set for every subset of $H \setminus \{\emptyset\}$, implying an index of least $2^{2^n - 1}$. ◀

References

- 1 D. Angluin, U. Boker, and D. Fisman. Families of DFAs as acceptors of omega-regular languages. In *Proc. of MFCS*, pages 11:1–11:14, 2016.
- 2 U. Boker and O. Kupferman. Translating to co-Büchi made tight, unified, and useful. *ACM Trans. Comput. Log.*, 13(4):29:1–29:26, 2012.
- 3 U. Boker, O. Kupferman, and A. Rosenberg. Alternation removal in Büchi automata. In *Proc. of ICALP*, volume 6199, pages 76–87, 2010.
- 4 J. R. Büchi. On a decision method in restricted second order arithmetic. In *Proc. Int. Congress on Logic, Method, and Philosophy of Science. 1960*, pages 1–12. Stanford University Press, 1962.
- 5 T. Colcombet and K. Zdanowski. A tight lower bound for determinization of transition labeled Büchi automata. In *Proc. of ICALP*, pages 151–162, 2009.
- 6 Y. Gurevich and L. Harrington. Trees, automata, and games. In *Proc. 14th ACM Symp. on Theory of Computing*, pages 60–65. ACM Press, 1982.
- 7 O. Kupferman and N. Piterman. Lower bounds on witnesses for nonemptiness of universal co-Büchi automata. In *Proc. of FoSSaCS*, volume 5504 of *LNCS*, pages 182–196. Springer, 2009.
- 8 O. Kupferman and M. Y. Vardi. Weak alternating automata are not that weak. *ACM Transactions on Computational Logic*, 2(2):408–429, 2001.
- 9 C. Löding. Optimal bounds for the transformation of omega-automata. In *Proc. of FSTTCS*, volume 1738 of *LNCS*, pages 97–109, 1999.
- 10 R. McNaughton. Testing and generating infinite sequences by a finite automaton. *Information and Control*, 9:521–530, 1966.
- 11 M. Michel. Complementation is more difficult with automata on infinite words. CNET, Paris, 1988.
- 12 S. Miyano and T. Hayashi. Alternating finite automata on ω -words. *Theoretical Computer Science*, 32:321–330, 1984.
- 13 A. W. Mostowski. Regular expressions for infinite trees and a standard form of automata. In *Computation Theory*, volume 208 of *LNCS*, pages 157–168. Springer, 1984.
- 14 D. E. Muller. Infinite sequences and finite machines. In *Proc. 4th IEEE Symp. on Switching Circuit Theory and Logical design*, pages 3–16, 1963.
- 15 N. Piterman. From nondeterministic Büchi and Streett automata to deterministic parity automata. *Logical Methods in Computer Science*, 3(3):5, 2007.
- 16 M. O. Rabin. Decidability of second order theories and automata on infinite trees. *Transaction of the AMS*, 141:1–35, 1969.
- 17 S. Safra. *Complexity of automata on infinite objects*. PhD thesis, Weizmann Institute of Science, 1989.
- 18 S. Safra. Exponential determinization for ω -automata with strong-fairness acceptance condition. In *Proc. 24th ACM Symp. on Theory of Computing*, 1992.
- 19 S. Schewe. Büchi complementation made tight. In *Proc. 26th Symp. on Theoretical Aspects of Computer Science*, volume 3 of *LIPICs*, pages 661–672. Schloss Dagstuhl, 2009.
- 20 S. Schewe and T. Varghese. Determinising parity automata. In *Proc. of MFCS*, pages 486–498, 2014.
- 21 R. S. Streett. Propositional dynamic logic of looping and converse. *Information and Control*, 54:121–141, 1982.
- 22 Q. Yan. Lower bounds for complementation of omega-automata via the full automata technique. *Logical Methods in Computer Science*, 4(1), 2008.