

**The Ministry of Education and Science of the Russian Federation**

Federal state autonomous educational institution of higher education  
“National Research Tomsk Polytechnic University”

<b>Institute</b>	IC (Institute of Cybernetics)
<b>Major</b>	15.03.01 “Mechanical engineering”
<b>Department</b>	Mechanical engineering and industrial robotics (MEIR)

**Diploma Project**

<b>Work theme</b>
<b>Master schedule projection of the reducer shaft manufacturing</b> (Разработка технологического процесса изготовления вала редуктора)

UDC 621.83.059.1:62-592-52.002

The student:

<b>Group</b>	<b>Last, first , middle name</b>	<b>Signature</b>	<b>Date</b>
8Л3И	Taha Mohamed Khaled Mohamed Таха Мохамед Халед Мохамед		

The supervisor:

<b>Post</b>	<b>Last, first , middle name</b>	<b>Scientific degree, a rank</b>	<b>Signature</b>	<b>Date</b>
Docent of dep. MEIR	Kozlov V.N.	Ph.D. (Engineering), Associate Professor		

**Consultants (Advisers):**

The section «Financial management»

<b>Post</b>	<b>Name</b>	<b>Scientific degree, a rank</b>	<b>Signature</b>	<b>Date</b>
Head of dep. Management	Chistyakova N.O	Ph.D. Associate Professor		

The section « Social responsibility»

<b>Post</b>	<b>Name</b>	<b>Scientific degree, a rank</b>	<b>Signature</b>	<b>Date</b>
Assistant of dep. “Health and safety”	Nevskii E. S.			

**Permission for the defense:**

<b>Fulfilling duties of the Head of department</b>	<b>Name</b>	<b>Scientific degree, a rank</b>	<b>Signature</b>	<b>Date</b>
MEIR	Vilnin A.D.			

Tomsk – 2017 г.

**The Ministry of Education and Science of the Russian Federation**

Federal state autonomous educational institution of higher education  
“National Research Tomsk Polytechnic University”

<b>Institute</b>	IC (Institute of Cybernetics)
<b>Major</b>	15.03.01 “Mechanical engineering”
<b>Department</b>	Mechanical engineering and industrial robotics (MEIR)

**Approved**

Fulfilling duties of the Head of department MEIR

\_\_\_\_\_ Vilnin A.D.

« \_\_\_\_ » 06. 2017

**Assignment**

**For executing of final qualification work**

In the form:

Bachelor Degree Project
-------------------------

To the student:

<b>Group</b>	<b>Name</b>
8Л3И	Taha Mohamed Khaled Mohamed

Work theme:

<b>Master schedule projection of the reducer shaft manufacturing</b> <b>(Разработка технологического процесса изготовления вала редуктора)</b>	
It is approved by the director's IC order	N 2960/с «26» 04. 2017 г.

Deadline for submission of the final copy by the student	05.06.17
--	----------

**The technical task:**

<b>Initial data to work:</b>	The detail drawing; the annual program of release $N_a=10000$ pieces
The list of section to research, designing and working out of questions:	
<b>1. The technological part:</b>	To execute the analysis of manufacture-ability of a detail; to prove of an initial blank choice; to design technological process; to calculate allowances for machining of all surfaces; to execute the dimensional analysis of technological process and to calculate the technological sizes; to calculate cutting modes and demanded power of machine tools, time for performance of each operation and all technological process
<b>2. The design part:</b>	To design the special fixture for one of operations; to define necessary force of a clamping; to write the design description
<b>The list of a graphics:</b>	1. The detail drawing - format A2; 2. Operational cards of technological process - format A1; 3. Complex scheme of the dimensional analysis - format A1; 4. The assembly drawing of fixture – format A1;

	<p>5. The specification of assembly drawing of fixture – format A4; 6. Calculation of the technological cost of manufacturing of a detail - format A1</p>
--	---

**Advisers for sections of final qualification work**

Section	The Adviser
Technological part	Docent of dep. MEIR Kozlov V.N.
Design part	Docent of dep. MEIR Kozlov V.N.
Financial management	Head of dep. Management Chistyakova N.O.
Social responsibility	Assistant of dep. “Health and safety” Nevskii E. S.
The summary in Russian and English languages	Docent of dep. MEIR Kozlov V.N.

Names of sections which should be written in Russian and foreign (English) languages
The summary

<b>Date when the individual assignment was issued to the student under the linear schedule</b>	14.01.17
--	----------

**Individual assignment was issued to the student by the supervisor:**

Post	Name	Scientific degree, a rank	Signature	Date
Docent of dep. MEIR	Kozlov V.N.	Ph.D. (Engineering), Associate Professor		14.01.2017

**Date when the individual assignment was issued to the student:**

Group	Name	Signature	Date
8J13H	Taxa M.X.M.		14.01.2017

**Министерство образования и науки Российской Федерации**  
 федеральное государственное автономное образовательное учреждение  
 высшего образования  
**«НАЦИОНАЛЬНЫЙ ИССЛЕДОВАТЕЛЬСКИЙ  
 ТОМСКИЙ ПОЛИТЕХНИЧЕСКИЙ УНИВЕРСИТЕТ»**

<b>Институт</b>	ИК
<b>Направление подготовки</b>	15.03.01 «Машиностроение»
<b>Кафедра</b>	Технология машиностроения и промышленная робототехника

**ДИПЛОМНЫЙ ПРОЕКТ**

<b>Тема работы</b>
<b>Разработка технологического процесса изготовления вала редуктора</b>

УДК 621.83.059.1:62-592-52.002

Студент:

Группа	ФИО	Подпись	Дата
8ЛЗИ	Таха Мохамед Халед Мохамед		

Руководитель:

Должность	ФИО	Ученая степень, звание	Подпись	Дата
Доцент каф.ТМСПр	Козлов В.Н.	к.т.н., доцент		

**КОНСУЛЬТАНТЫ:**

По разделу «Финансовый менеджмент, ресурсоэффективность и ресурсосбережение»

Должность	ФИО	Ученая степень, звание	Подпись	Дата
Зав каф. Менеджмент	Чистякова Н.О.			

По разделу «Социальная ответственность»

Должность	ФИО	Ученая степень, звание	Подпись	Дата
Ассистент	Невский Е.С.			

**ДОПУСТИТЬ К ЗАЩИТЕ:**

И.о. зав. кафедрой	ФИО	Ученая степень, звание	Подпись	Дата
ТМСПр	Вильнин А.Д.			

**Министерство образования и науки Российской Федерации**  
 федеральное государственное автономное образовательное учреждение  
 высшего образования  
**«НАЦИОНАЛЬНЫЙ ИССЛЕДОВАТЕЛЬСКИЙ  
 ТОМСКИЙ ПОЛИТЕХНИЧЕСКИЙ УНИВЕРСИТЕТ»**

<b>Институт</b>	ИК
<b>Направление подготовки</b>	15.03.01 «Машиностроение»
<b>Кафедра</b>	Технология машиностроения и промышленная робототехника

УТВЕРЖДАЮ:

И.о. зав. кафедрой ТМСПр

\_\_\_\_\_ Вильнин А.Д.  
 (подпись) (дата) (ФИО)

**ЗАДАНИЕ**

**на выполнение выпускной квалификационной работы**

В форме:

бакалаврской работы
---------------------

Студенту:

<b>Группа</b>	<b>ФИО</b>
8ЛЗИ	Таха Мохамед Халед Мохамед

Тема работы:

Разработка технологического процесса изготовления вала редуктора	
Утверждена приказом директора ИК	N 2960/с «26» 04. 2017 г.

Срок сдачи студентом выполненной работы	05.06.17
---	----------

**Техническое задание:**

<b>Исходные данные к работе:</b>	Чертеж детали; годовая программа выпуска $N_z=10000$ <i>шт</i>
----------------------------------	---

<b>Перечень подлежащих исследованию, проектированию и разработке вопросов:</b>	
<b>1. Технологическая часть:</b>	Выполнить анализ технологичности детали; обосновать выбор заготовки; спроектировать технологический процесс; рассчитать припуски на обработку всех поверхностей; выполнить размерный анализ технологического процесса и рассчитать технологические размеры; рассчитать режимы резания и требуемую мощность станков, рассчитать время выполнения каждой операции и всего технологического процесса
<b>2. Конструкторская часть:</b>	Спроектировать специальное приспособление для одной из

	операций; определить необходимую силу зажима; сделать описание конструкции.
<b>Перечень графического материала:</b>	<ol style="list-style-type: none"> <li>1. Чертёж детали – формат А2;</li> <li>2. Операционные карты технологического процесса – формат А1;</li> <li>3. Комплексная схема размерного анализа – формат А1;</li> <li>4. Сборочный чертёж приспособления – формат А1;</li> <li>5. Спецификация приспособления – формат А4;</li> </ol>

#### **Консультанты по разделам выпускной квалификационной работы**

Раздел	Консультант
Технологическая часть	Доц. каф. ТМСПР Козлов В.Н.
Конструкторская часть	Доц. каф. ТМСПР Козлов В.Н.
Финансовый менеджмент, ресурсоэффективность и ресурсосбережение	Зав каф. Менеджмента Чистякова Н.О.
Социальная ответственность	Ассистент каф. БЖД Невский Е.С.
Аннотация на английском языке	Доц. каф. ТМСПР Козлов В.Н.

<b>Названия разделов, которые должны быть написаны на русском и и иностранном (английском) языках</b>
Аннотация

<b>Дата выдачи задания для раздела по линейному графику</b>	14.01.17
---	----------

#### **Задание выдал руководитель:**

Должность	ФИО	Ученая степень, звание	Подпись	Дата
Доцент каф. ТМСПР	Козлов В.Н.	к.т.н., доцент		14.01.2017

#### **Задание принял к исполнению студент:**

Группа	ФИО	Подпись	Дата
8ЛЗИ	Таха Мохамед Халед Мохамед		14.01.2017

Томск – 2017 г.

## TABLE OF CONTENTS

	Page
1. Introduction.....	9
2. The abstract.....	10
3. Definition of a manufacturing type.....	11
4. Technological process designing of part manufacturing.....	12
5. Calculation of allowances.....	21
6. Calculation of manufacturing sizes.....	25
7. Calculation of cutting modes.....	44
8. Technical fixing of technological process laboriousness .....	78
9. Design section.....	97
10.Economic section.....	100
11.Social responsibility .....	112
12.Literature.....	132

## **АННОТАЦИЯ**

Целью выпускной квалификационной работы является разработка технологического процесса для подтверждения квалификации «бакалавр техники и технологии» по направлению 15.03.01 «Технология, оборудование и автоматизация машиностроительных производств».

Выпускная квалификационная работа включает в себя проектирование технологического процесса обработки детали типа "вала редуктора" и содержит: анализ чертежа и технологичности детали; способ получения заготовки; расчет припусков на обработку; разработку технологического процесса, размерный анализ технологического процесса; выбор и расчет режимов резания; расчёт и проектирование пневматического приспособления для фрезерования шпоночной пазы с мембранной пневмокамерой; расчёт времени на обработку детали для каждой операции, расчёт технологической себестоимости изготовления детали; решение вопросов производственной безопасности, эргономики, пожарной безопасности и охраны окружающей среды.

Приложение содержит эскиз детали, сборочный чертёж приспособления и спецификацию. В графической части работы представлены операционные карты разработанного технологического процесса, лист комплексной схемы обработки с размерным анализом, сборочный чертёж приспособления с мембранной пневмокамерой для закрепления заготовки на фрезерные операции, лист расчёта технологической себестоимости изготовления детали.

## **THE SUMMARY**

The purpose of final qualification paper (Diploma Thesis) is working out of a master schedule for qualification affirming «the bachelor of engineering and technique» in a major 15.03.01 "Technology, the equipment and automation of engineering manufactures».

Diploma Thesis includes projection of a master schedule machining a part "Shaft of reducer" and contains: the assaying of the drawing and manufacturability of the part; a choice of method of initial workpiece manufacturing; calculation of allowances in machining; master schedule working out, the dimensional analysis of the master schedule; a choice and calculation of cutting mode; calculation and design of a milling operation tool holding device with the membrane pneumatic chamber; calculation of time for workpiece machining for each process, calculation of the technological cost price of the part manufacture; the decision of questions of industrial safety, ergonomics, fire safety and preservation of the environment.

The application contains the part sketch, an assembly drawing of workholding device and the specification. In a graphic part of Diploma Thesis there are cards of the designed master schedule, sheet of the complex circuit of part machining with the dimensional analysis, the assembly drawing of workholding device with the membrane pneumatic chamber for workpiece fixing on milling process, sheet of calculation of the technological cost price of the part manufacturing.

## **1. INTRODUCTION**

Production efficiency, its technical progress, quality of let out production in many respects depend on outstripping development of manufacture of the new equipment, machines, machine tools and devices, from the introduction of methods of the technical and economic analysis ensuring the solution to technical questions and economic efficiency of technological and design development.

The purpose of this Diploma Paper is to outline the development of technological process and designing of the attachment for the milling of key slot 8H9 (clamping on V-block with a pneumatic drive).

THE ABSTRACT  
Of Diploma Thesis

Working out of manufacturing technology of the part “Shaft of reducer”  
By student gr. 8J3И Taha Mohamed Khaled Mohamed

The diploma thesis is executed on 132 p. of the explanatory note, contains 39 fig., 31 tab., 11 references, 8 sheets of supplement.

Keywords: reducer shaft, allowance, technological size, dimensional analysis, cutting mode, master schedule, production estimate, the membrane pneumatic chamber, work holding device calculation, technological cost price, social responsibility.

Object of research is manufacturing technology of the part “Shaft of reducer”.

The operation purpose - qualification affirming «the bachelor of engineering and technique» in a major 15.03.01"Technology, equipment and automation of engineering manufactures».

During the research were spent: the analysis of the drawing and fabricability of a part, initial workpiece choice, projection of a master schedule machining of a part “Shaft of reducer”, calculation of allowances for machining all surfaces, the dimensional assaying of a master schedule and calculation of the technological sizes, calculation of cutting mode and demanded power of machine tools, calculation of time of execution of each process and all master schedule, design of special workholding device for milling process, calculation of necessary force of fixing, the exposition of workholding device construction, calculation of the technological cost price of manufacture of a part, the assaying of harmful factors on manufacture and the decision of safety issues of operation, operation at emergency situations and actions for their prevention, the assaying of influence of production factors on environment.

As a result of research the master schedule and special workholding device have been designed, the technological cost price of manufacture of a detail is calculated which is equal 1 373.89 ruble. Operation safety issues are solved, actions for prevention of emergency situations are developed.

The basic constructive, technological and technique-operational characteristics: at organizing of business lot production the standard time of one part is 20.7 minutes. For manufacturing the part “Shaft of reducer” are required following equipments: the lathe with turning machine tool 16K20, the grinding machine 3M153, Milling center machine 8631.

Introduction degree: by results of diploma thesis defense on the state certifying commission it will be solved, whether it is necessary to recommend workings out to introduction on manufacture.

Field of application: manufacture of engineering production.

Economic significance of diploma thesis is high enough.

In the future it is planned to participate in organizing of the part manufacturing.

## 2. DEFINITION OF A MANUFACTURING TYPE

The annual program of products  $N = 10000$  pieces.

The real annual fund of an operating time of the equipment is determined from the recommendations for the table 4 [4, page 23] for work in 2 shifts:  $F_r = 4015$  h.

We determine a step of details release (manufacturing):

$$t_m = \frac{F_r \cdot 60}{N} = \frac{4015 \cdot 60}{10000} = 24.9 \left( \frac{\text{min}}{\text{piece}} \right),$$

Where  $F_r$  - the real annual fund of an operating time of the equipment, hour.

The data on existing (similar) factory technological process or on integrated fixing of operations are given in tab. 1.

Table 1. Duration of operations of the existing factory technological process

№ of operation	The name of operation	Operation cycle per part (OCP) of technological operation $t_{oc}$ , min.
1	Face milling	0.62
2	Turret-lathe (Rough)	2.75
3	Turret-lathe (Rough)	1.38
4	Turret-lathe (Semi-Finish)	2.58
5	Turret-lathe (Semi-Finish)	2.83
6	Key slot-Milling	6.19
7	Thread cutting	0.87
8	Heat Treatment	0.52
9	Grinding	1.4
10	Grinding	1.57
	Total floor-to-floor time $\sum T_f = 20.7$ min.	

Quantity of operations  $n=10$ .

Total operation cycle per part (OCP) of technological) of all operations:

$$T_{oc} = \sum t_{oc} = 20.7 \text{ minutes.}$$

We shall define (determine) average floor-to-floor time according to the formula:

$$t_{oc\ av} = T_{oc} / n = 20.7 / 10 = 2.07 \text{ min.}$$

We shall define factor of manufacturing type according to the formula:

$$k_m = t_m / t_{oc\ av} = 24.9 / 2.07 = 12.$$

Since  $10 \leq k_m \leq 20$ , the type of manufacture is a business lot production (or **medium-batch production**).

## 2.1. Account of parts quantity in a set (batch size)

The annual program of release  $N = 10000$  pieces;  $t_{oc\ av} = 2.07$  min.

Periodicity of start - release of products  $a = 5$  days.

Number of working days in one year  $F = 240$  days.

We shall define settlement quantity of parts (details) in a set according to the formula:

$$n = N \times a / F = 10000 \times 5 / 240 = 208.33 \approx 208 \text{ pieces,}$$

Where  $a$  is the quantity of storage days. For small and inexpensive details it is 2...12 days.

The settlement number of shifts for processing of parts set on a site (shop) is defined according to the formula:

$$c = (t_{oc\ av} \times n) / (D \times k_l) = (2.07 \times 208) / (480 \times 0.8) = 2.69.$$

Where  $D$  is the duration of one shift, min.;  $k_l$  is coefficient of work time loss.

The accepted number of shifts for processing of details set on a site:  $c_{ac} = 2$  shifts.

The accepted number of details in a set is:

$$n_{ac} = c_{ac} \times 480 \times 0.8 / T_{f\ av} = 2 \times 480 \times 0.8 / 2.07 = 371 \text{ pieces} \approx 400 \text{ pieces.}$$

## 3. TECHNOLOGICAL PROCESS DESIGN OF SHAFT MACHINING

### 3.1. ANALYSIS OF SHAFT MACHINING ADAPTABILITY

The part (blank) is made of steel 40X (0.40 % of carbon C, Cr – 1%, sulfur S < 0.09 %; phosphorus P < 0.035 %), therefore blank (production) can be manufactured in different ways and shapes: by hot or cold rolling, stamping (punching), forging; rod. The part has large difference of diameters, which not allow using rod as a blank and thus the use of casting or punching techniques for mass and business lot production. But punching technique in steel production is more preferable (in order to avoid cavities in the body of the blank). The material structure is more uniform and that is why we would use forged or stamped blank.

The preliminary processing of external surfaces is made on a lathe machine

tool, a key slot 10H9– on a vertical-milling machine tool with use of a special attachment with clamping on V-block with a pneumatic drive, the machining of the thread M12-8g – by a die on the lathe.

The final processing should be made on grinding machine tools, as the sizes  $\text{Ø}25\text{n}6$ ,  $\text{Ø}32\text{s}7$  and  $\text{Ø}32\text{g}6$  should be executed with the close tolerance (with the sixth and seventh grade of tolerance) and with a small roughness of surfaces ( $R_a \leq 0.8$  and 1.25 microns).

The end faces of the part should be machined by face milling simultaneously, since the length of the shaft 15h14 (note: high accuracy is not required).

The shape of the part is convenient for manufacturing. The processing of the external surfaces should be machined in rough and semi-finish operations. It is also necessary to use center holes in order to obtain a higher accuracy of the radial circular run-out of surfaces  $\text{Ø}25\text{n}6$ ,  $\text{Ø}32\text{s}7$  and  $\text{Ø}32\text{g}6$ .

The shaft is machined between two centers; that is why center holes are drilled in the first operation.

The configuration of the part provides easy removal of chips. This type of a blank allows producing the part by machining it in the universal self-centering 3-jaw chuck for the rough (draft) operations and between two centers - in finishing operations (in collet chuck or on self-centering mandrel with expansion bushing when there is a central hole). The application of exact attachments at final processing is necessary in connection with the close-off tolerance (0.05 mm) of radial circular run-out of the external cylindrical surface  $\text{Ø}25\text{n}6$ ,  $\text{Ø}32\text{s}7$  and  $\text{Ø}32\text{g}6$ . The application of thermal operation requires. Material (steel 40X) allows to carry out quenching with the specified hardness (it is better to use steel 40X for reduction of required speed of cooling and reduction the possibility of warp of the part). Final processing of surfaces with the exact sizes ( $\text{Ø}25\text{n}6$ ,  $\text{Ø}32\text{s}7$  and  $\text{Ø}32\text{g}6$ ) should be carried out after thermal operation for the elimination of the possibility of warp of the part. Thus for the final processing, sufficient allowance should be left in the point of view of a part warping.

### 3.2. STEPS OF TECHNOLOGICAL DESIGN

The designing of technological processes (TP) of machining begins with the study of service purpose of the part, its technical requirements, and norms of accuracy and program of release, analysis of an opportunity of the enterprise on processing the given part.

The designing of TP represents a multi alternative task, the correct solution of which requires the realization of a number of calculations. Before beginning the designing of kinds of processing of blank surfaces and methods of achievement of their accuracy appropriate to the requirements of the drawing, the type of manufacturing equipment existing at the shop must be defined or established.

For low accuracy initial blanks, TP begins with rough processing of surfaces having greatest stocks. Stocks are removed in first turn from those surfaces on which the defects are possible. This is done for the purpose of the prompt elimination of spoilage.

The step is further designed with a principle of processing at first rough, and then more exact (accurate) surfaces. The most exact surfaces are processed in last turn.

At the end of the step, the minor operations (drilling of small holes, threading and tapping, removal (manufacturing) of chamfers, burring etc.) are also carried out. The easily damaged surfaces are processed at the final stage of TP.

At the requirement of the part quenching all minor surfaces are necessarily processed finally before the quenching, exact surfaces - previously, but they are not rougher than ninth grade of tolerance, saving stocks for final processing. The final processing of surfaces with the exact sizes is made after thermal operations.

For the considered part ("shaft") during the first operation, the surface of the shaft  $\text{Ø}25\text{n}6$  should be processed, because it will be the base surface for the subsequent operation. Since it is required to supply accuracy of mutual arrangement to surfaces  $\text{Ø}25\text{n}6$ ,  $\text{Ø}32\text{g}6$  and  $\text{Ø}32\text{s}7$ , during the second operation it is necessary to use a three jaw self-centering chuck with center of a right side.

For increase of accuracy of the positioning in the first operation at first it is required to process an end face of blank and to drill a center hole.

For drawing up of a TP route it is required previously to define the processing quantity of each surface. For this purpose, it is better to take the surface with the most exact size and to make a sequence of processing. Thus stocks are consecutive "covered" on the final (design) size, which allows us to receive the intermediate technological sizes. In our task the most exact external size is  $\text{Ø}25\text{n}6$ . It should be processed with 6th grade of tolerance, before - with 9th grade of tolerance, and earlier - with 12th grade of tolerance. We begin to write down the technological sizes from the end (design size is written first) and we go from the right hand to the left, for example:  $34.78\text{h}12 \rightarrow 32.68\text{h}9 \rightarrow 31.08\text{h}7 \rightarrow 30\text{g}6$ .

If it is necessary to carry out heat treatment (quenching, tempering and so on) we shall write the route of processing:

$27.5\text{h}16 \rightarrow 25.7\text{h}11 \rightarrow 25.38\text{h}9 \rightarrow \text{Heat treatment} \rightarrow 25\text{n}6$ .

$$2Z_{min} = 1.8 \text{ mm} \qquad 2Z_{min} = 0.4 \text{ mm} \qquad 2Z_{min} = 0.32 \text{ mm}$$

Such sequence allows avoiding one operation (before heat treatment with 9th grade of tolerance), however it can result in the increase of the possibility of the occurrence of a spoilage and hence, increase in the cost price of the part manufacturing.

In tab. 3.1 at first we write down a sequence of processing and operational sketches, but we shall calculate values of the intermediate technological sizes later, after the calculation of minimal stocks of processing (tab. 4.1). In operational sketches we shall write intermediate technological sizes approximately at first. Then we shall write a new table of the technological route where we shall write only definitive technological sizes.

Table 3.1. Route of the part "shafts" machining

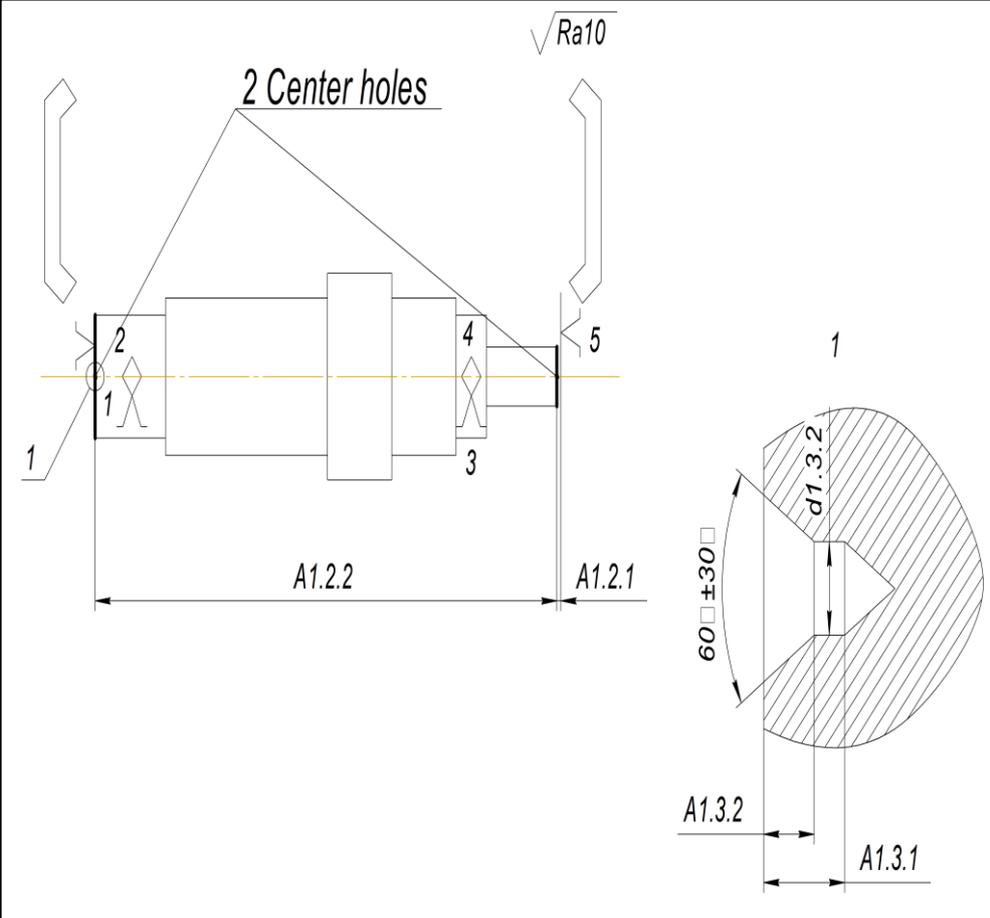
<p><b>Operation 1</b></p>	 <p>The technical drawing shows a shaft with several features and dimensions. The main shaft has a diameter of <math>d1.3.2</math> and a length of <math>60 \pm 30</math>. There are two center holes, each with a diameter of <math>d1.3.2</math>. The distance between the center holes is <math>A1.2.2</math>. The distance from the right end of the shaft to the right center hole is <math>A1.2.1</math>. The distance from the left end of the shaft to the left center hole is <math>A1.3.2</math>. The distance from the left end of the shaft to the right center hole is <math>A1.3.1</math>. The surface finish is <math>\sqrt{Ra10}</math>. The drawing is labeled '2 Center holes' and '1'.</p>
<p>1. Mount the workpiece on V-block</p>	
<p>2. Mill faces 1&amp;2 simultaneously ensuring size <math>A1.2.1</math> and <math>A1.2.2</math></p>	
<p>3. Drill two center holes simultaneously</p>	
<p>4. Take off the workpiece</p>	

**Operation 2 (Rough turning)**

1. Mount the workpiece.
2. Cut the surface (1) ensuring size (2).
3. Cut the surface (3) ensuring size (4).
4. Cut the surface (5) ensuring size (6).
5. Cut the surface (7) on pass.
6. Cut chamfer (8).
7. Take off the workpiece.

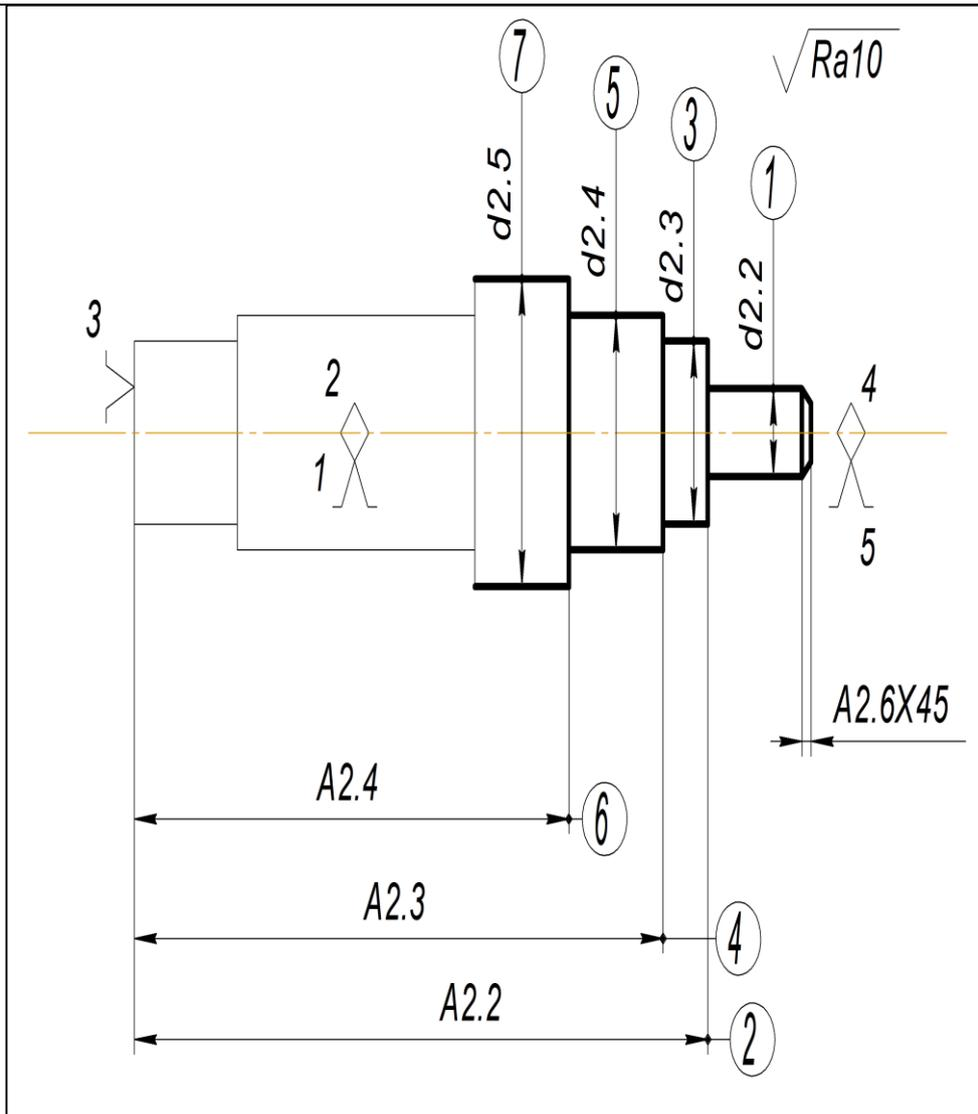

**Operation 3 (Rough turning).**

1. Mount the workpiece.
2. Cut the surface (1) ensuring size (2).
3. Cut the surface (3) ensuring size (4)
4. Take of the workpiece.

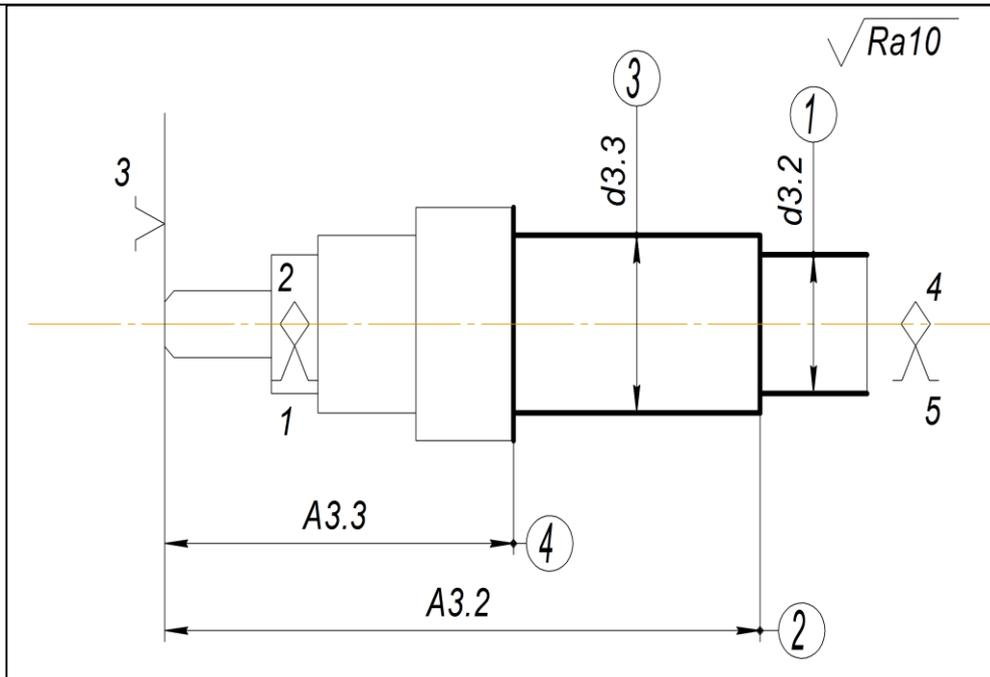

**Operation 4 (Semi-finish turning).**

1. Mount the workpiece.
2. Cut surface (1) ensuring size (2).
3. Cut surface (3) ensuring size (4).
4. Cut chamfer (5).
5. Cut chamfer (6).
6. Cut chamfer (7).
7. Take off the workpiece.

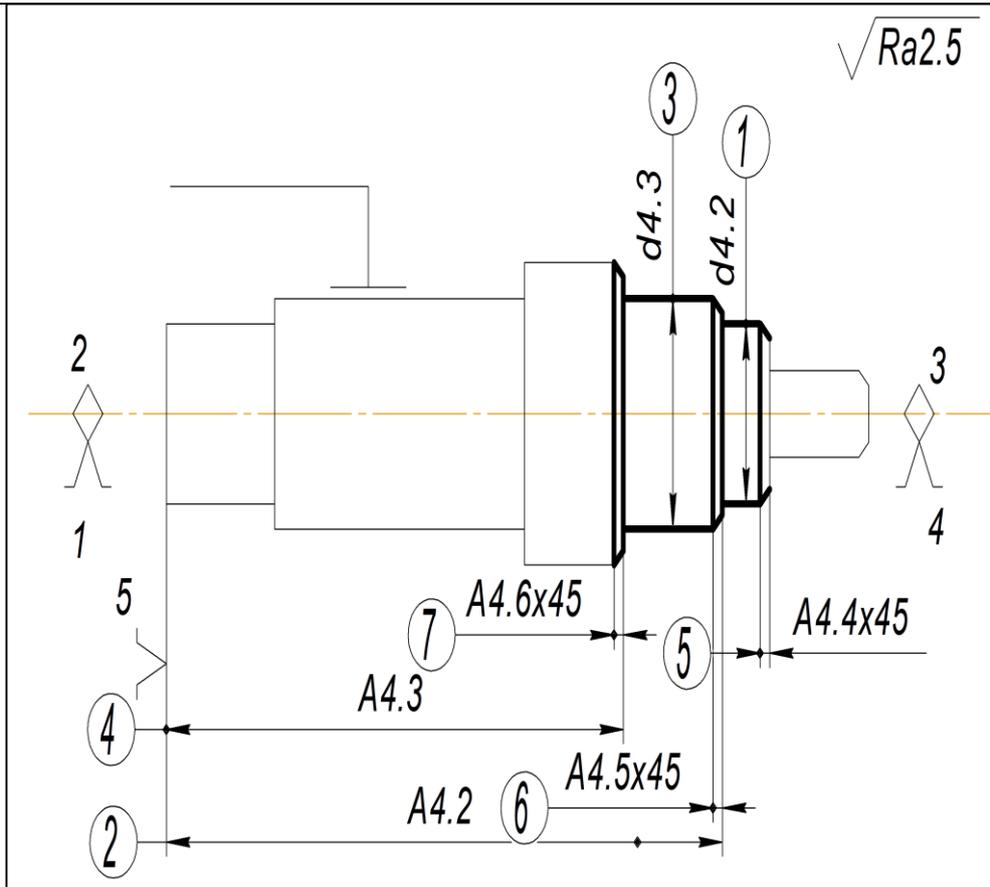

**Operation 5 (Semi-finish turning).**

1. Mount the workpiece.
2. Cut surface (1) ensuring size (2).
3. Cut surface (3) ensuring size (4).
4. Cut chamfer (5).
5. Cut chamfer (6).
6. Cut chamfer (7).
7. Take off the workpiece.

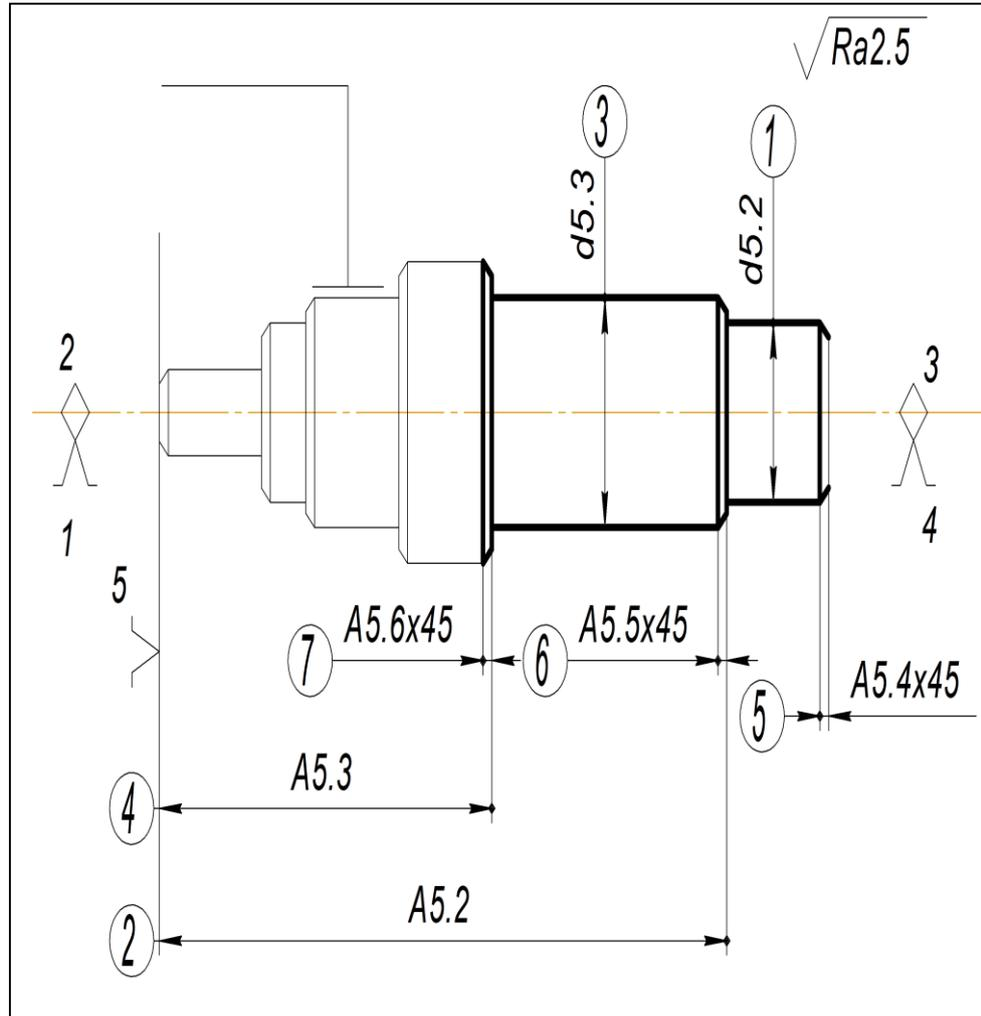

**Operation 6 (Milling process).**

1. Mount the workpiece.
2. Mill key slot (1) ensuring sizes (2), (3),(4).
3. Take off the workpiece.

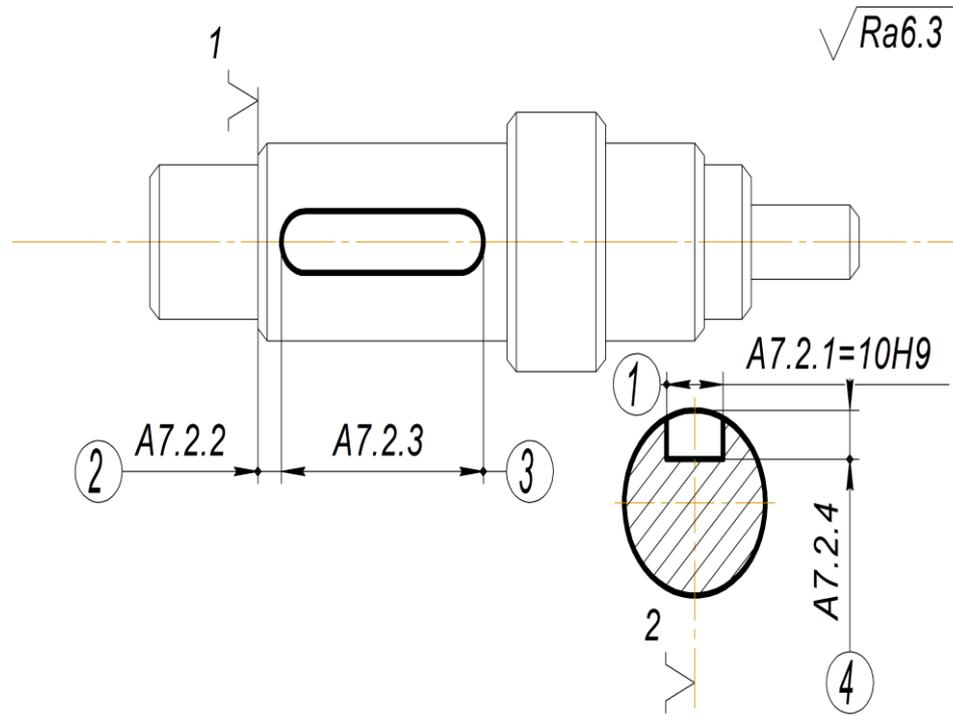

**Operation 7 (Thread cut).**

1. Mount the workpiece.
2. Cut thread (1) ensuring size (2).
3. Take off the workpiece

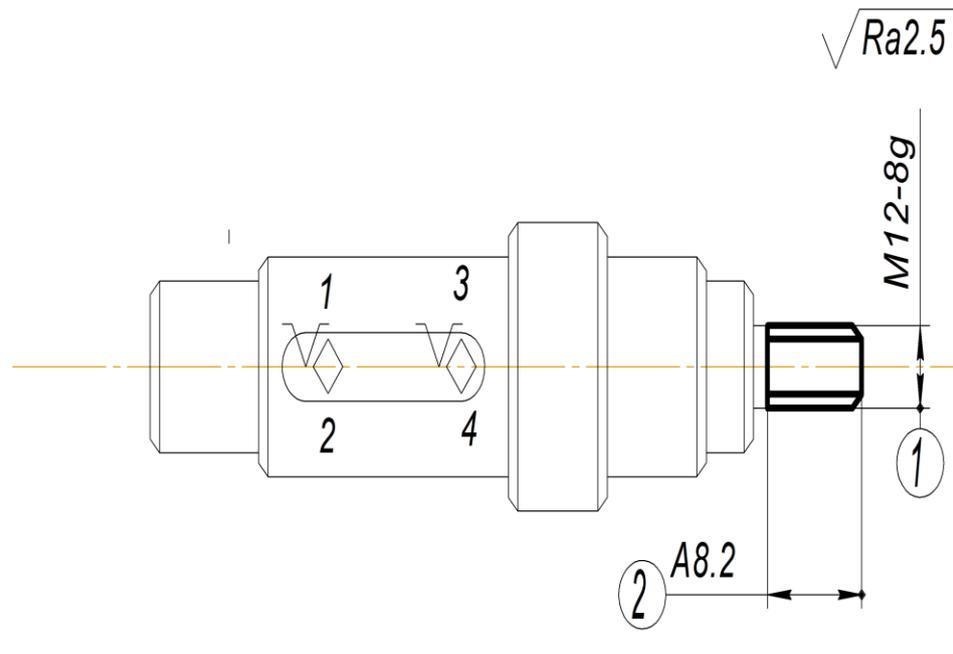

**Operation 8 (Heat treatment).**

Quench and temper workpiece to HRC 42....46.

**Operation (Grinding) 9**

1. Mount the workpiece.
2. Grind surface (1) ensuring size (2).
3. Grind surface (3) ensuring size (4).
4. Take off the workpiece.

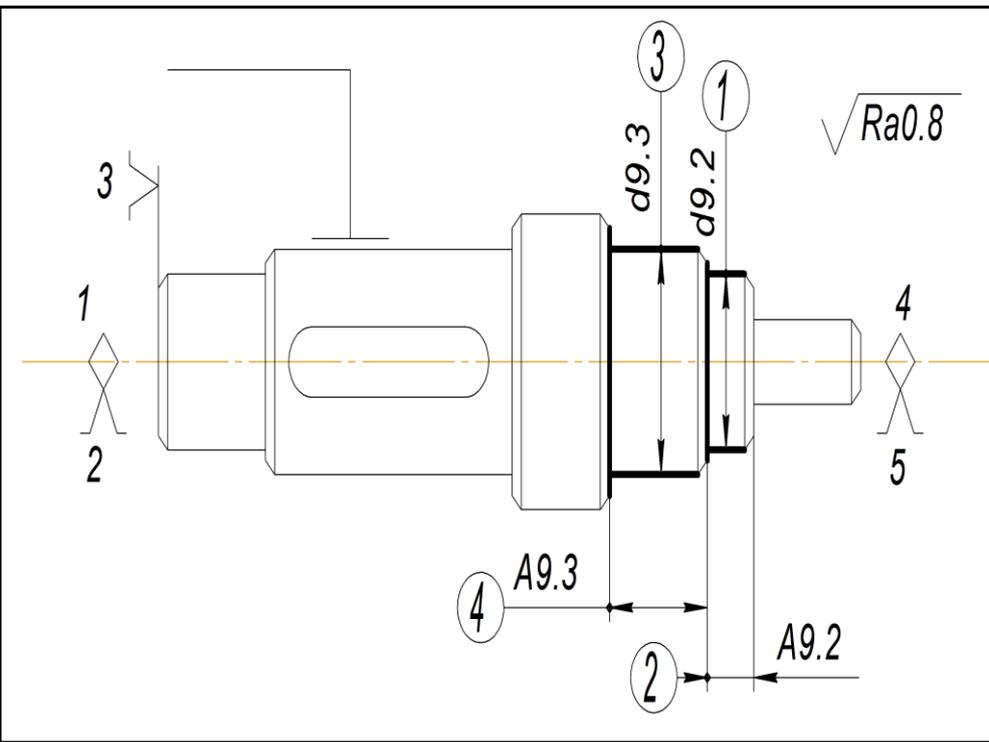

**Operation (Grinding) 10**

1. Mount the workpiece.
2. Grind surface (1) ensuring size (2).
3. Grind surface (3) ensuring size (4).
4. Take off the workpiece.

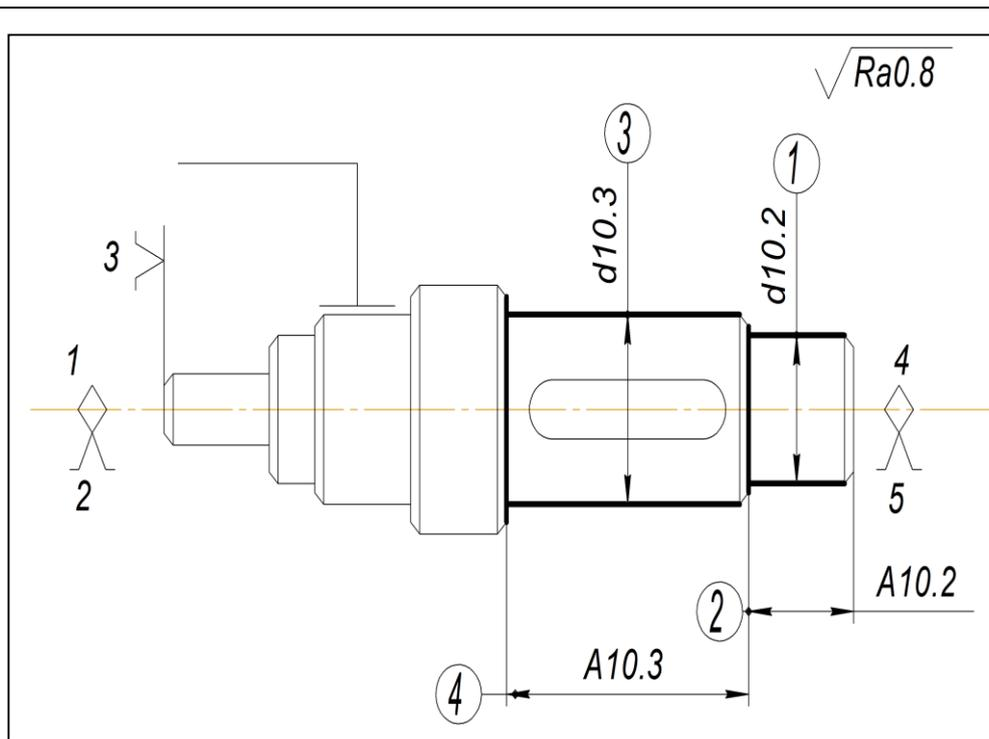

**Operation 11 (Size control)**

Size control according to the design drawing.

## 4. CALCULATION of ALLOWANCES

**Stock** (allowance) is a layer of a material, removed in machining. Its minimal thickness  $Z_{\min}$  depends on many factors, but the major ones are:

1. Roughness of the surface received from previous machining (index  $i-1$ ) -  $Rz_{i-1}$ ;
2. Thickness of defective layer of the surface received from previous machining -  $T_{\text{def } i-1}$ ;
3. Curvature (warp) of the surface received from previous machining -  $\rho_{i-1}$ ;
4. Error of basing and fastening received at considered machining (index  $i$ ) -  $\varepsilon_i$ .

If stock is less minimal, the traces from the previous machining will stay, which is not allowable. Stock is removed per one or several cuts, if the thickness is too large. Minimal stock for considered machining (operation) is defined from the tables or calculated by the formulas, where we can calculate minimal stock taking into account the seldom probability of occurrence in the same direction of warp of a surface received from previous machining ( $\rho_{i-1}$ ) and error of basing and fastening received at considered machining ( $\varepsilon_i$ ) for rotation surfaces:

$$2z_{\min.i} = 2 \cdot \left( Rz_{i-1} + T_{\partial.i-1} + \sqrt{(\rho_{i-1}^2 + \varepsilon_i^2)} \right), \quad (4.1)$$

Where  $2z_{\min.i}$  is a minimal stock of rotation surfaces for considered machining.

It is better to calculate minimal stock taking into account the probability of occurrence in the same direction of warp of a surface received at the previous manufacturing ( $\rho_{i-1}$ ) and error of basing and fastening received at considered manufacturing ( $\varepsilon_i$ ) for rotation surfaces:

$$2z_{\min.i} = 2 \cdot (R_{z.i-1} + T_{\partial.i-1} + \rho_{i-1} + \varepsilon_i), \quad (4.2)$$

For flat surfaces (non-rotating surfaces) minimal stock is calculated by the formula:

$$z_{\min.i} = Rz_{i-1} + T_{\text{def } i-1} + \rho_{i-1} + \varepsilon_i.$$

### 4.1. Stock calculation for the surface processing Ø25n6

We make stock calculations of the surface processing Ø25n6 by drawing up of tab. 4.1, in which the technological route of the surface processing and all values of stock elements are written consistently.

Total value  $Rz$  and  $T_{\text{def}}$ , describing quality of a surface of blank from cold rolling process, is determined from tab. 27 [4, page 66]. For each subsequent technological transition these values are determined from tab. 29 [4, page 67].

We determine total deviation of a warp error  $\rho_{\text{warp}}$  and displacement  $\rho_{\text{dis}}$  by the formula:

$$\rho = \sqrt{(\rho_{\text{dis}}^2 + \rho_{\text{warp}}^2)},$$

Where:  $\rho_{\text{dis}}$  - error of blank on displacement concerning an axis in a radial direction;  
 $\rho_{\text{warp}}$  - error of blank on warp.

We find size of a residual spatial deviation of a blank for a surface processing Ø30h7. The error of blank on displacement is defined from tab. 32 [4, page 72]:

$$\rho_{\text{dis}} = 0.360 \text{ mm} = 360 \text{ } \mu\text{m}.$$

The blank error of a warp is defined by product of length of blank  $\ell$  on specific warp  $\Delta_w$ , which depends on the method of blank manufacturing on the previous operation:

$$\rho_{warp} = \Delta_w \times \ell = 0.12 \times 60 = 7.2 \mu\text{m},$$

Where specific warp  $\Delta_w$  is defined from tab. 32 [4, page 72].

Total deviation of an error on warp and displacement:

$$\rho_0 = \sqrt{(360^2 + 7.2^2)} = 360.4 \mu\text{m} \approx 400 \mu\text{m}.$$

Residual spatial deviation of the blank  $\rho_0 = 400$  microns.

After that we find value of a residual spatial deviation after preliminary turning (rough turning) using the factor of residual warp  $k_{warp}$  and warp of blank

$$\rho_{blank}: \rho_1 = k_{warp} \times \rho_{blank} = 0.08 \cdot 400 = 32 \mu\text{m} \text{ we take } 90 \mu\text{m}.$$

Residual spatial deviation after semi-finish (fair) turning:

$$\rho_2 = k_{warp} \times \rho_{blank} = 0.02 \cdot 400 = 8 \text{ we take } 45.$$

Residual spatial deviation after grinding:  $\rho_3 = k_{warp} \times \rho_{blank} = 0.1 \cdot 50 = 5 \mu\text{m}.$

Table 4.1. Calculation of stocks and limit technological sizes for technological transitions for surfaces manufacturing

Name of processing step	Allowance elements, $\mu\text{m}$				Calculated allowance $2z_{\min}, \mu\text{m}$	Accepted size $d_p, \text{mm}$	Tolerance T, $\mu\text{m}$	Size limits, mm	
	$R_z$	$T$	$\rho$	$\varepsilon$				$d_{\min}$	$d_{\max}$
<b>Surface <math>\text{Ø}25\text{n}6^{(+0.028/+0.015)}</math></b>									
Stamping (h14)	150	300	400			$\text{Ø}29,7^{+0,8}_{-0,4}$	1200	29,3	30,5
Rough turning (h12)	40	60	90	500	$2 \cdot 1350 = 2700$	$\text{Ø}26,6\text{h}12$	210	26,38	26,59
Semi-finish turning (h9)	10	40	45	100	$2 \cdot 290 = 580$	$\text{Ø}25,8\text{h}9$	52	25,718	25,77
Heat treatment HRC 42...46	40	100	200	----					
Grinding (n6)	3,2	15	10	5	$2 \cdot 345 = 690$	$\text{Ø}25\text{n}6$	13	25,015	25,028
<b>Surface <math>\text{Ø}32\text{g}6^{(-0.009/-0.025)}</math></b>									
Stamping (h14)	150	300	400	---		$\text{Ø}36,68^{+0,8}_{-0,4}$	1200	36,28	37,48
Rough turning (h12)	40	60	90	500	2700	$\text{Ø}33,58\text{h}12$	250	33,33	33,58
Semi-finish turning (h9)	10	40	45	100	580	$\text{Ø}32,75\text{h}9$	62	32,681	32,743
Heat treatment HRC 42...46	40	100	200						
Grinding (g6)	3,2	15	10	5	690	$\text{Ø}32\text{g}6$	16	31,975	31,991
<b>Surface <math>32\text{s}7^{(+0.068/+0.043)}</math></b>									
Stamping (h14)	150	300	400	----		$\text{Ø}36,75^{+0,8}_{-0,4}$	1200	36,35	37,55
Rough turning (h12)	40	60	90	500	2700	$\text{Ø}33,65\text{h}12$	250	33,4	33,65
Semi-finish turning (h9)	10	40	45	100	580	$\text{Ø}32,82$	62	32,758	32,82
Heat treatment HRC 42...46	40	100	200						

Grinding (s7)	3,2	15	10	5	690	Ø32s7	25	32,043	732,068
---------------	-----	----	----	---	-----	-------	----	--------	---------

Name of processing step	Allowance elements, µm				Calculated allowance 2Z <sub>min</sub> , µm	Accepted size d <sub>p</sub> , mm	Tolerance T, µm	Size limits, mm	
	R <sub>Z</sub>	T	ρ	ε				d <sub>min</sub>	d <sub>max</sub>
<b>Surface Ø42h14(-0.62)</b>									
Stamping (h14)	150	300	400			ø45 <sup>+0,8</sup> <sub>-0,4</sub>	1200	44,7	45,9
Rough turning (h14)	40	60	90	500	2700	Ø42h14	620	41,38	42
<b>151h14(length)</b>									
Stamping (h14) <b>right side</b>	250	400	600	---		155,6 <sup>+0,8</sup> <sub>-0,4</sub>	1200	155,15	156,35
Rough milling (h14) <b>right side</b>	40	60	90	500	1750	153,4h14	1000	152,35	153,35
Stamping (h14) <b>left side</b>	250	400	600			153,4h14	1000	152,35	153,35
Rough milling (h14) <b>left side</b>	40	60	90	100	1350	151h14	1000	150	151

As the blank is maintained on a self-centering mandrel, we shall define an error of installation by the formula:

$$\varepsilon_i = \sqrt{(\varepsilon_b^2 + \varepsilon_f^2)} = \varepsilon_f = 100 \mu m,$$

Where an error of basing  $\varepsilon_b \rightarrow 0$  (since at installation of the blank in the attachment the technological base coincides with design base);  $\varepsilon_f$  is an error of fastening (clamping).

For the part "shaft" minimal stocks are determined by the equation (4.1) for processing a surface  $\text{Ø}25n6^{(+0.028}_{+0.015})$ :

- for the preliminary turning (with 12th grade of tolerance):

$$2z_{\min.i} = 2 \cdot \left( R_{z,i-1} + T_{\rho,i-1} + \sqrt{(\rho_{i-1}^2 + \varepsilon_i^2)} \right) = 2 \cdot \left( 150 + 300 + \sqrt{(400^2 + 500^2)} \right) = 2180.6 \mu m$$

- for the semi-finish (fair) turning (with 9th grade of tolerance):

$$2z_{\min.i} = 2 \cdot \left( 40 + 60 + \sqrt{(90^2 + 100^2)} \right) = 469 \mu m;$$

- for the grinding (with 7th grade of tolerance):

$$2z_{\min.i} = 2 \cdot \left( 40 + 100 + \sqrt{(200^2 + 5^2)} \right) = 680 \mu m.$$

It is better for us to take into account the small scale manufacturing of the part and for increasing of manufacturing reliability we shall calculate minimal stock (allowance) of surface  $\text{Ø}25n6$  by the formula (4.2) taking into account the probability of occurrence in the same direction of warp ( $\rho_{i-1}$ ) and error of basing and fastening ( $\varepsilon_i$ ) for rotation surfaces:

- for the preliminary turning (with 12 grade of tolerance):

$$2z_{\min.i} = 2 \cdot (R_{z,i-1} + T_{\partial,i-1} + \rho_{i-1} + \varepsilon_i) = 2 \cdot (150 + 300 + 400 + 500) = 2 \times 1350 = 2700 \mu\text{m};$$

- for the semi-finish (fair) turning (with 9 grade of tolerance):

$$2z_{\min i} = 2(40 + 60 + 90 + 100) = 2 \times 290 = 580 \mu\text{m};$$

- for the grinding (with 7 grade of tolerance):

$$2z_{\min i} = 2(40 + 100 + 200 + 5) = 2 \times 345 = 690 \mu\text{m}.$$

Results of calculations by the formula (4.2) are written in tab. 4.1.

## 4.2. Stock calculations for a surface $\text{Ø}32g6(-\frac{0.009}{0.025})$

We do calculations of processing stocks for a surface  $\text{Ø}32g6(-\frac{0.009}{0.025})$  by drawing up of tab. 4.1, in which the technological route of a surface processing and all values of stock elements are written consistently. Total values Rz and  $T_{\text{def}}$ , describing quality of a cold rolling blank surface are determined with the help of tab. 27 [4, page 66]. For each subsequent technological transition these values are determined using tab. 29 [4, page 67].

We determine total deviation of a warp error  $\rho_{\text{warp}}$  and displacement  $\rho_{\text{dis}}$  by the formula (4.3):

$$\rho = \sqrt{(\rho_{\text{dis}}^2 + \rho_{\text{warp}}^2)},$$

Where:  $\rho_{\text{dis}}$  - error of blank on displacement concerning an axis in a radial direction;  
 $\rho_{\text{warp}}$  - error of blank on warp.

The error of blank on displacement is defined from tab. 32 [4, page 72]:

$$\rho_{\text{dis}} = 0.5 \text{ mm} = 500 \mu\text{m}.$$

The blank error of a warp is defined by product of length of blank  $\ell$  on specific warp  $\Delta_w$ , which is dependent on the method of blank manufacturing in the previous operation:

$$\rho_{\text{warp}} = \Delta_w \times \ell = 0.12 \times 53 = 6.36 \mu\text{m},$$

Where specific warp  $\Delta_w$  is defined from tab. 32 [4, page 72].

Total deviation of an error on warp and displacement:

$$\rho_0 = \sqrt{(400^2 + 6.36^2)} \approx 400 \mu\text{m}$$

Residual spatial deviation of blank  $\rho_0 = 400 \mu\text{m}$ .

As the blank is maintained between centers, we shall define the error of installation by the formula:

$$\varepsilon_i = \sqrt{(\varepsilon_b^2 + \varepsilon_f^2)} = \varepsilon_f = 100 \mu\text{m},$$

Where an error of basing  $\varepsilon_b \rightarrow 0$  (since at installation of blank in the attachment the technological base coincides with design base);  $\varepsilon_f$  is an error of fastening (clamping).

Minimal stocks for processing the surface  $\text{Ø}32g6\left(\begin{smallmatrix} -0.009 \\ -0.025 \end{smallmatrix}\right)$  are calculated by the equation (4.2) for increasing of manufacturing reliability.

### 4.3. Stock calculations for a surface 151h14

We make calculations of processing stocks by the formula (4.3) for a surface 151h14 (-) by drawing up of tab. 4.1, in which the technological route of the surface processing and all values of stock elements are written consistently.

It is better to define warp of a surface received at the previous manufacturing ( $\rho_{i-1}$ ) and error of basing and fastening received at considered manufacturing ( $\varepsilon_i$ ) from machinist handbook.

We shall write these values in formula (4.3):

- for the preliminary milling of right face and left face end of the blank **simultaneously** (with 14 grade of tolerance):

$$\text{Right face } z_{\min i} = Rz_{i-1} + T_{\text{def } i-1} + \rho_{i-1} + \varepsilon_i = 250 + 400 + 600 + 500 = 1750 \mu\text{m};$$

$$\text{Left face } z_{\min i} = Rz_{i-1} + T_{\text{def } i-1} + \rho_{i-1} + \varepsilon_i = 250 + 400 + 600 + 100 = 1350 \mu\text{m};$$

Results of accounts by the formula (4.3) are written in tab. 4.1.

## 5. Calculation of manufacturing sizes

For calculating manufacturing sizes it is obligatory to make manufacturing size analysis, and define according to standards the manufacturing tolerance of each size depending on the type of process and the manufacturing datum "basing", sizes and tolerances are defined according to standards in table 4.4.

Table 4.4 sizes tolerances

<b>Forged</b>	
$TA_{01}$	1.2
$TA_{02}$	1.2
$TA_{03}$	1.2
$TA_{04}$	1.2
$TA_{05}$	1.2
$TA_{06}$	1.2

<b>Roughing</b>	
$TA_{1.2.2}$	0.2
$TA_{1.2.1}$	$0.2 + \rho = 0.2 + 0.8 = 1$
$TA_{2.2}$	$0.3 + \rho = 0.3 + 0.12 = 0.42$
$TA_{2.3}$	0.42
$TA_{2.4}$	0.42
$TA_{3.2}$	0.42
$TA_{3.3}$	0.42

<b>Semi-finishing</b>	
$TA_{43}$	$0.12 + 0.12 = 0.24$
$TA_{53}$	0.24
$TA_{52}$	0.24
$TA_{57}$	0.24

<b>Finishing</b>	
$TA_{9.2}$	0.08
$TA_{9.3}$	0.08
$TA_{10.2}$	0.08
$TA_{10.3}$	0.08

## 5.1 Size analysis of the manufacturing process

The purpose of size analysis consists of the estimation of technological processes quality. We check and correct, if it is necessary, deviations of sizes comparing final technological sizes with design sizes given on the executive (work) drawing.

The initial data for the size analysis are:

1. Drawing of the part.
2. Drawing of initial blank.
3. Technological process of the part processing.

We draw general scheme of the part processing and select sizes circuits, into which design sizes are included. Component links (making parts) in technological size circuits are the technological sizes, which are specified in the technological documentation (sizes of initial blank and all sizes obtained at machining). The final technological sizes should coincide with the sizes specified on the drawing, i.e. with the design sizes. If such concurrence is not present, i.e. the technological size does not coincide with design size (design size is not maintained directly), it is necessary to reveal (to define) such size circuit, into which the considered design size and technological sizes are maintained for reception of the design size. Such design size

is a closing link, and since it is required to execute it with given base (nominal) size and deviations, it is referred to as initial. Closing links in technological size circuits can be design and technological sizes, and also stocks for processing.

We consistently consider size circuits with one unknown technological size and we consider base value and deviations of this link. If there are several unknown technological sizes, we calculate the tolerances of the unknown sizes (usually by method of equal accuracy), and then we nominate values and deviations of all unknown technological sizes except for one, concerning which the decision will be made.

We draw general scheme of the part processing (fig. 5.1). Then we check the coincidence of final technological sizes with the sizes specified on the drawing.

For example

$K_2, K_3, K_4, K_5, K_6$  are not processed directly, that is why it is necessary to reveal (to define) such size circuit, into which the considered design sizes ( $K_2, K_3, K_4, K_5$  and  $K_6$ ) and technological sizes are maintained for obtaining the design sizes. Those design sizes are closing links, and since it is required to execute them with the given base sizes and deviations, they are referred to as initials.

Then after that we must ensure design sizes using method of complete interchangeability.

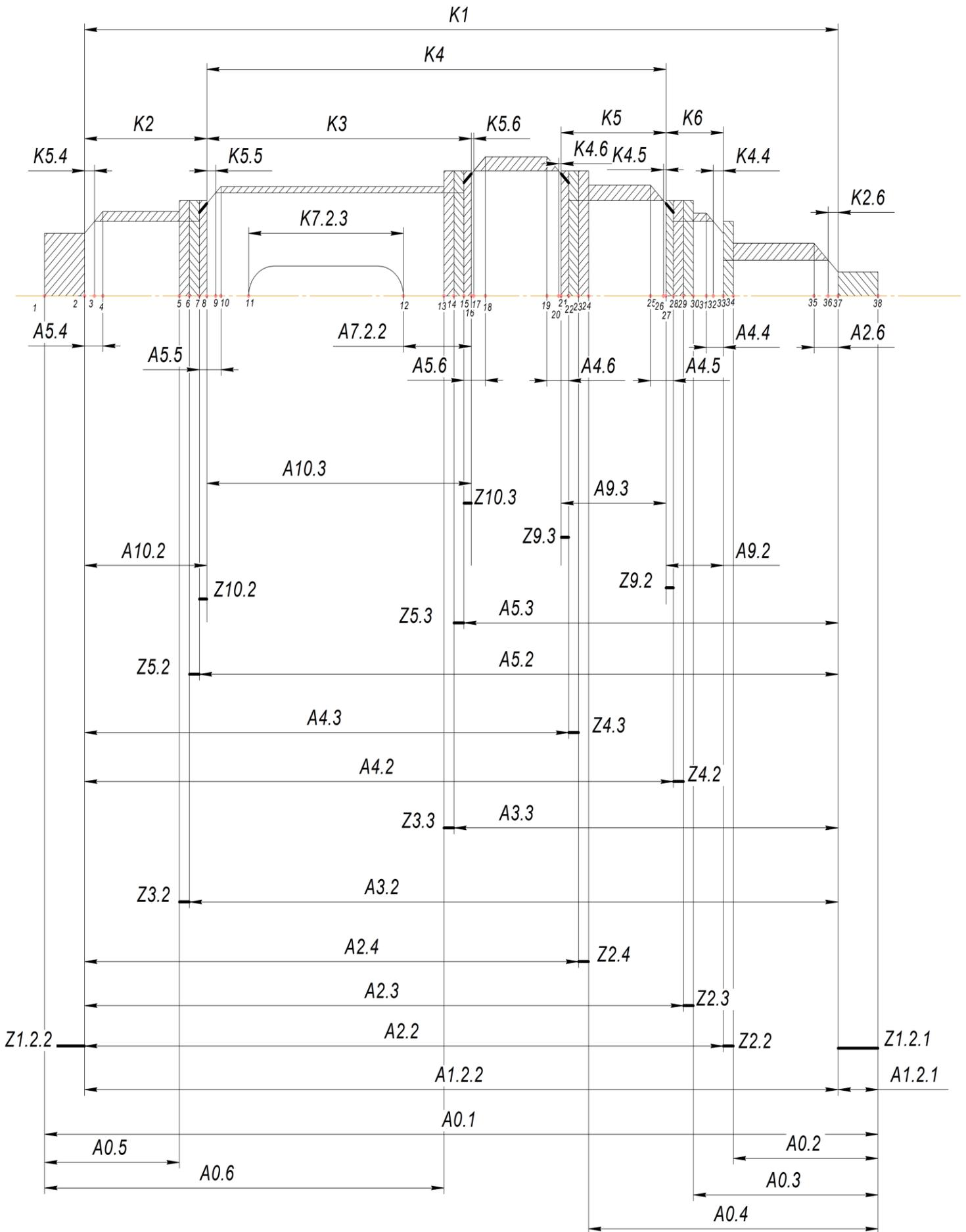

1)  $K_1=A_{1.2.2}$  directly ensured.

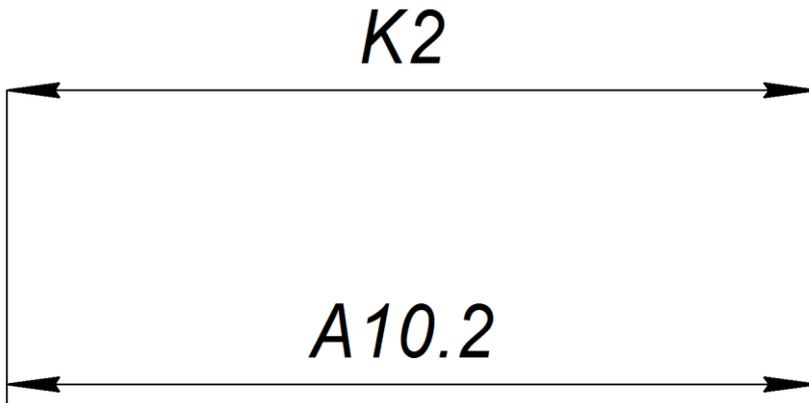

2)  $TK_2=TA_{10.2}$   
Directly ENSURED

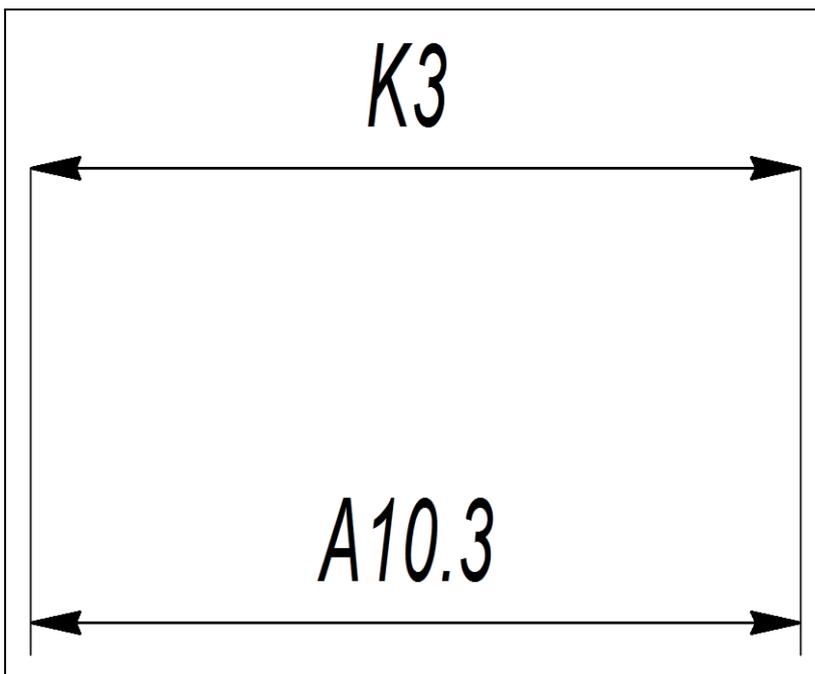

3)  $TK_3=TA_{10.3}$   
Directly ENSURED

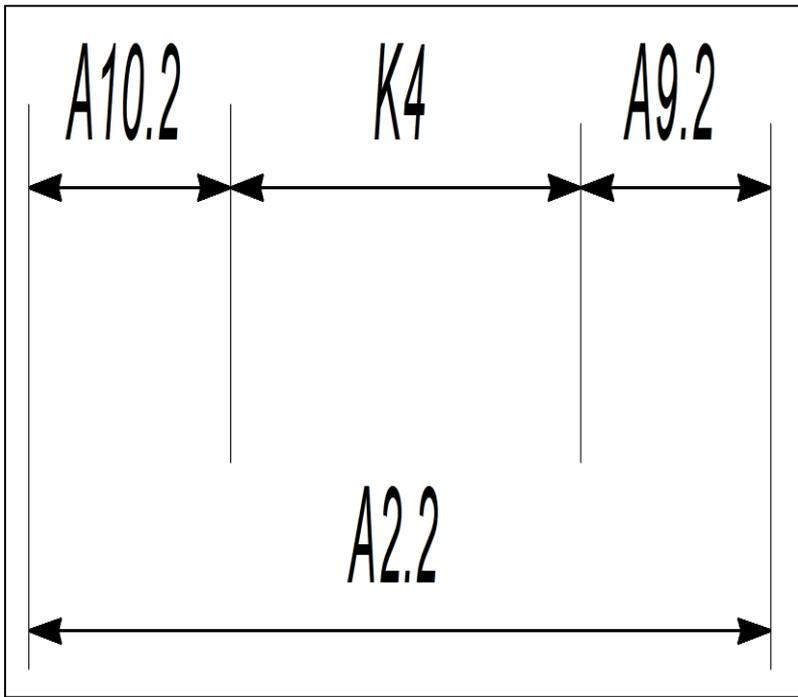

4)  
 $TK_4 \geq TA_{2.2} + TA_{10.2} + TA_{9.2}$   
 $TK_4 = 0.87;$   
 $0.87 \geq 0.08 + 0.08 + 0.42 = 0.58$   
 $0.87 \geq 0.58$  **ENSURED.**

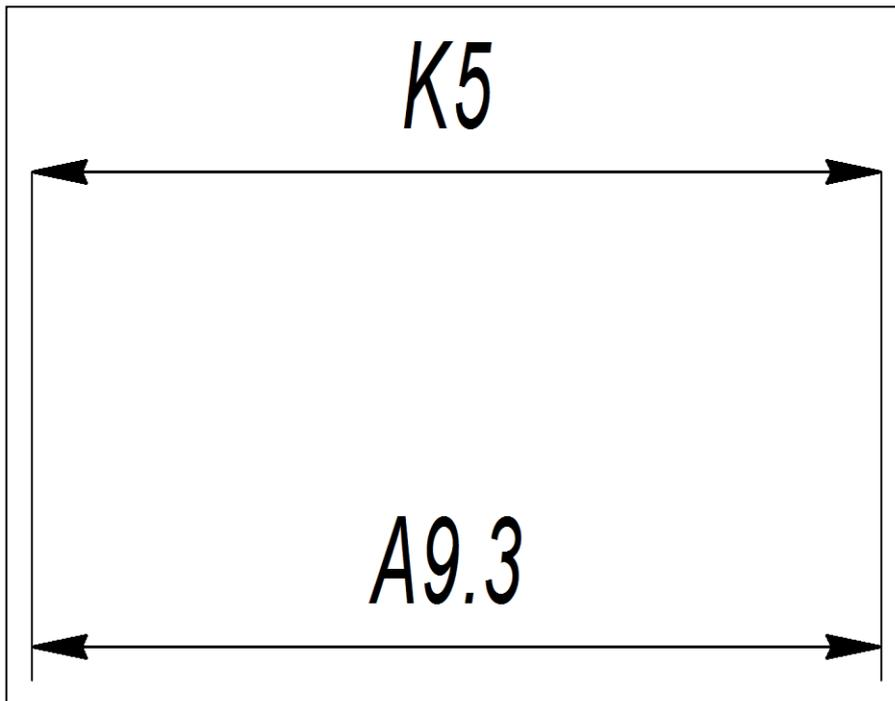

5)  $TK_5 = TA_{9.3}$  **Directly**  
**ENSURED**

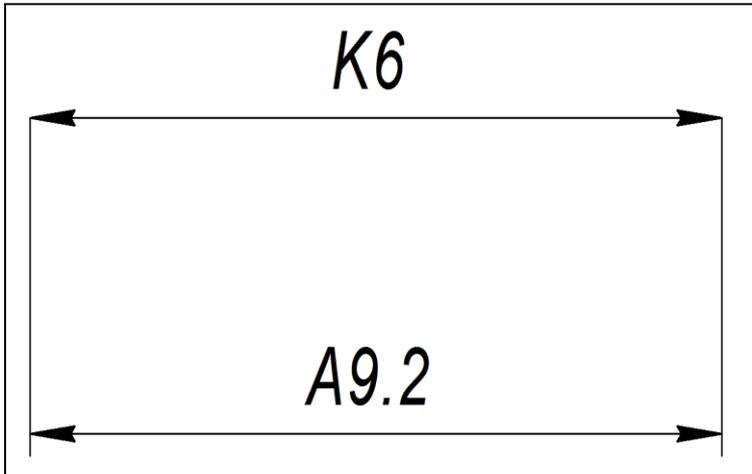

6)  $TK_6=TA_{9,2}$   
ENSURED.

Directly

## 5.2. Calculation of manufacturing sizes

We make calculations of technological sizes with the help of size circuit analyses. At first we have some manufacturing sizes are equal to designing sizes as listed below:  $A_{9,2}=K_6$

$$A_{9,3}=K_5$$

$$A_{10,3}=K_3$$

$$A_{10,2}=K_2$$

### 5.2.1. Calculation of initial manufacturing size for the whole length

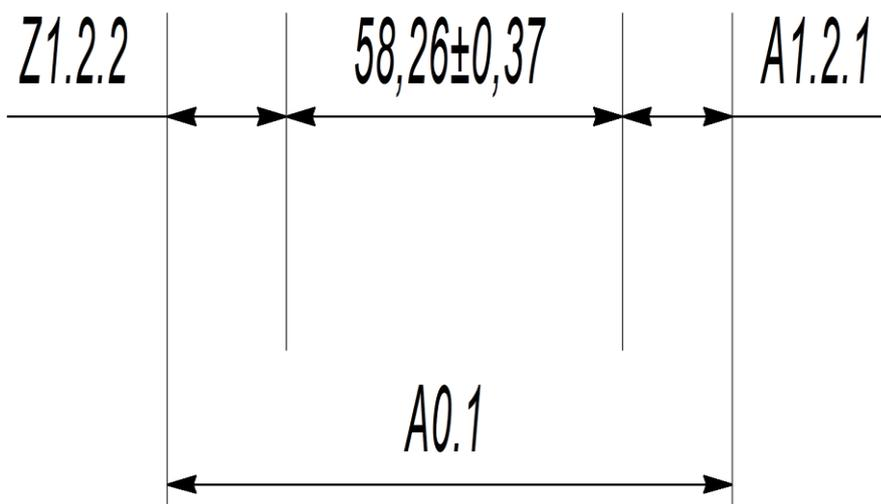

**Finding manufacturing size  $A_{0.1}$ :**

$$Z_{1.2.2min} = A_{0.1min} - A_{1.2.2max} - A_{1.2.1max}$$

$$A_{0.1min} = Z_{1.2.2min} + A_{1.2.2max} + A_{1.2.1max} = 1.35 + 151 + 2.75 = 155.1 \text{ mm}$$

$$A_{0.1\max} = A_{0.1\min} + TA_{0.1} = 155.1 + 1.2 = 156.3 \text{ mm}$$

$$A_{0.1\text{accepted}} = 155.5_{-0.4}^{+0.8}$$

### 5.2.2 Calculation of manufacturing sizes for machining $\text{Ø}12\text{h}14$

Finding size  $A_{2.2}$ :

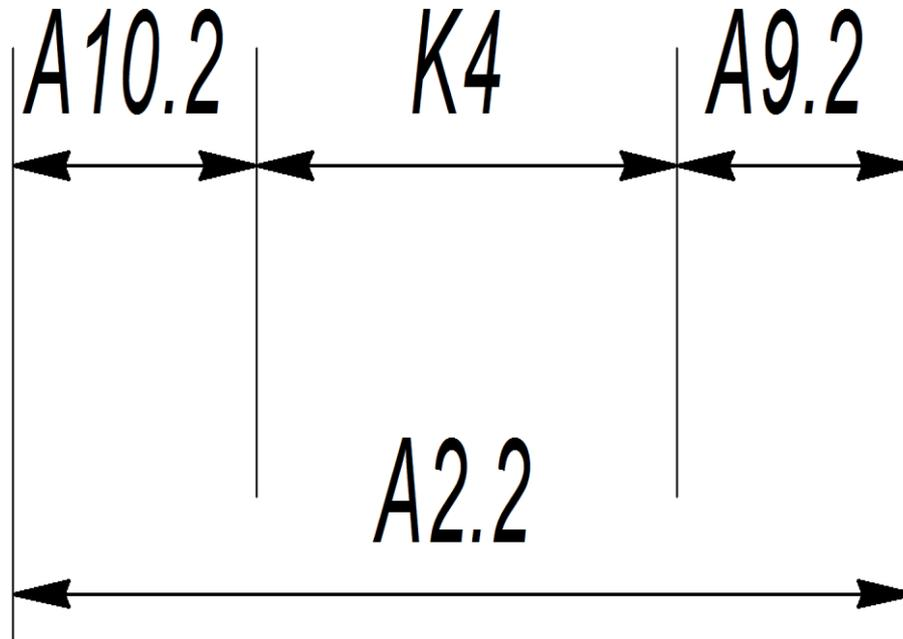

$$K_4 = A_{2.2} - A_{10.2} - A_{9.2};$$

$$K_{4\max} = A_{2.2\max} - A_{10.2\min} - A_{9.2\min}$$

$$TK_4 \geq TA_{2.2} + TK_{10.2} + TK_{9.2}$$

$$0.87 > 0.42 + 0.08 + 0.08 = 0.58$$

$$A_{2.2\max} = K_{4\max} + A_{10.2\min} + A_{9.2\min} = 95 + 23 + 10 = 128 \text{ mm}$$

$$A_{2.2\min} = A_{2.2\max} - TA_{2.2} = 128 - 0.42 = 127.58$$

$$A_{2.2\text{accepted}} = 128_{-0.42}$$

**5.2.3 Calculation of manufacturing sizes for machining Ø12h14**  
**Finding initial size  $A_{0.2}$ :**

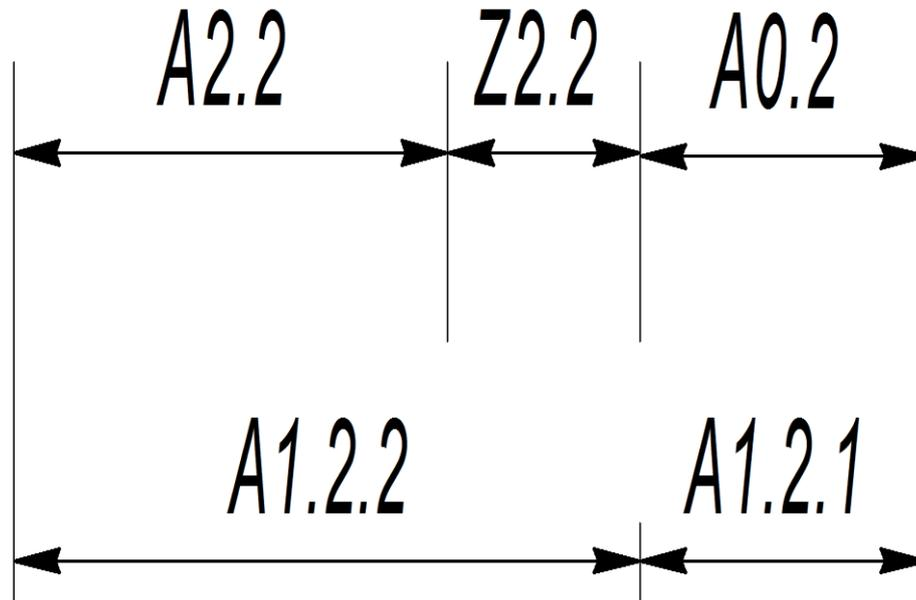

$$Z_{2.2\min} = A_{1.2.2\min} + A_{1.2.1\min} - A_{0.2\max} - A_{2.2\max}$$

$$A_{0.2\max} = A_{1.2.2\min} + A_{1.2.1\min} - Z_{2.2\min} - A_{2.2\max} = 150.8 + 1.75 - 2.7 - 128 = 21.85\text{mm}$$

$$A_{0.2\min} = A_{0.2\max} - TA_{0.2} = 21.85 - 1.2 = 20.65\text{mm}$$

$$A_{0.2\text{accepted}} = 21^{+0.8}_{-0.4}$$

$$Z_{2.2\max} = A_{1.2.2\max} + A_{1.2.1\max} - A_{0.2\min} - A_{2.2\min} = 151 + 2.75 - 20.65 - 127.58 = 5.52\text{mm}$$

**5.2.4 Calculation of manufacturing sizes for machining Ø25n6**  
**Finding size  $A_{4.2}$ :**

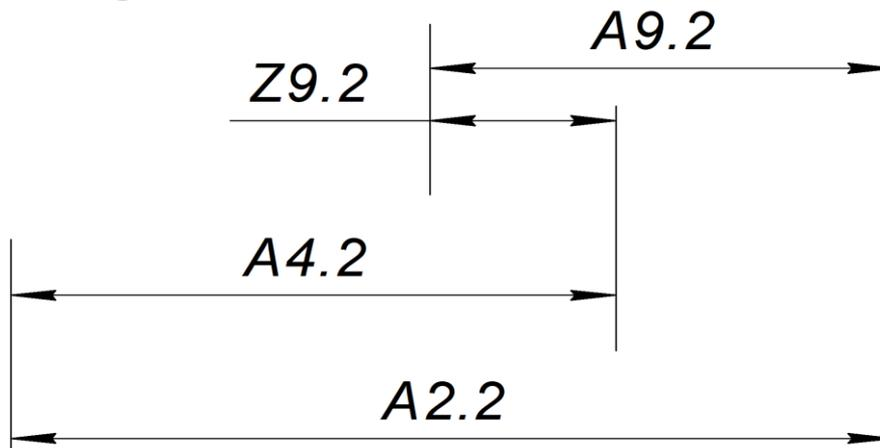

$$Z_{9.2\min} = A_{4.2\min} + A_{9.2\min} - A_{2.2\max}$$

$$A_{4.2\min} = Z_{9.2\min} - A_{9.2\min} + A_{2.2\max} = 0.69 - 10 + 128 = 118.69\text{mm}$$

$$A_{4.2\max} = A_{4.2\min} + TA_{4.2} = 118.69 + 0.24 = 118.93\text{mm}$$

$$A_{4.2\text{accepted}}=118.95_{-0.24}$$

**Finding size  $A_{2.3}$ :**

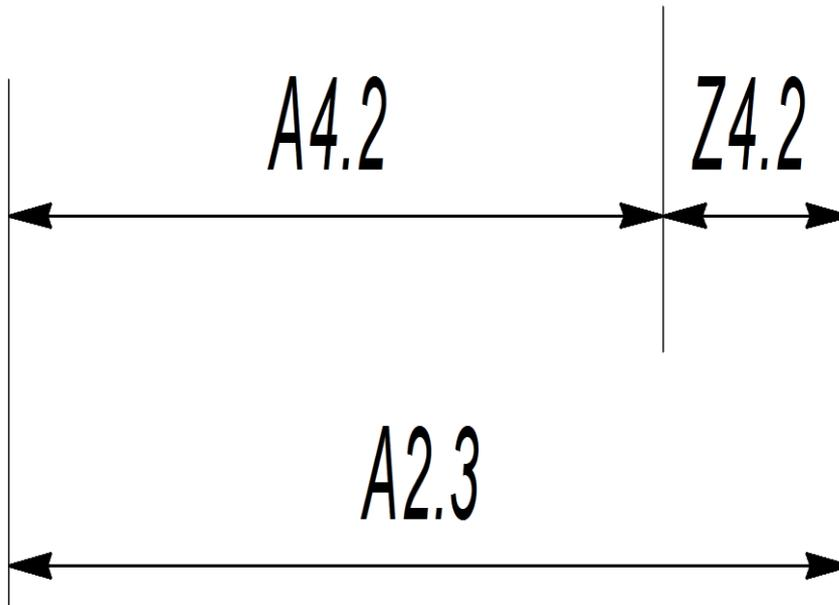

$$Z_{4.2\text{min}}=A_{2.3\text{min}}-A_{4.2\text{max}}$$

$$A_{2.3\text{min}}=Z_{4.2\text{min}}+A_{4.2\text{max}}=0.58+118.95=119.53\text{mm}$$

$$A_{2.3\text{max}}=119.53+0.42=119.95\text{mm}$$

$$A_{2.3\text{accepted}}=119.95_{-0.42}$$

$$Z_{4.2\text{max}}=A_{2.3\text{max}}-A_{4.2\text{min}}=119.95-118.69=1.26\text{mm}$$

**Finding initial size  $A_{0.3}$ :**

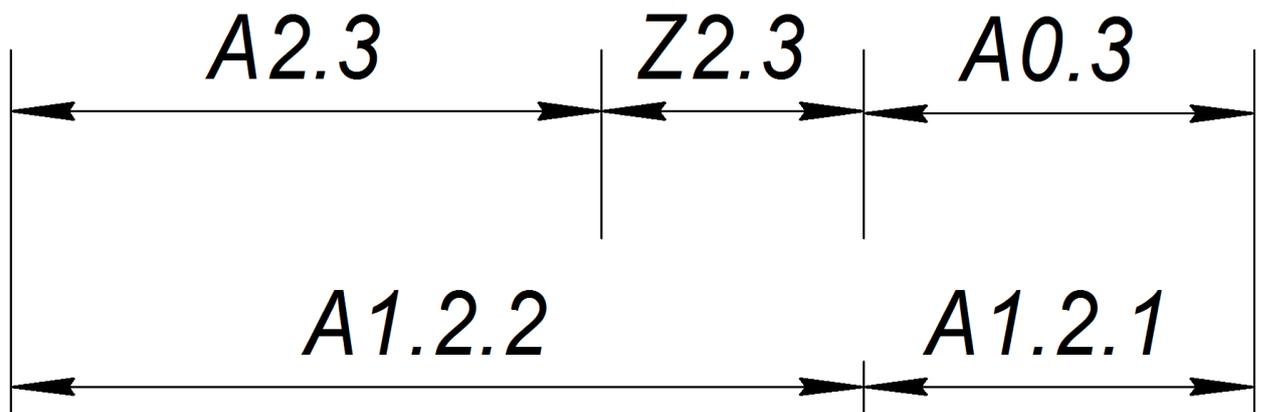

$$Z_{2.3\text{min}}=A_{1.2.2\text{min}}+A_{1.2.1\text{min}}-A_{2.3\text{max}}-A_{0.3\text{max}}$$

$$A_{0.3\text{max}}=A_{1.2.2\text{min}}+A_{1.2.1\text{min}}-Z_{2.3\text{min}}-A_{2.3\text{max}}=150.8+1.75-2.7-119.53=30.32\text{mm}$$

$$A_{0.3\text{min}}=30.32-1.2=29.12\text{mm}$$

$$A_{0.3\text{accepted}}=29.5_{-0.4}^{+0.8}$$

$$Z_{2.3\text{max}}=A_{1.2.2\text{max}}+A_{1.2.1\text{max}}-A_{2.3\text{min}}-A_{0.3\text{min}}=151+2.75-119.11-29.12=5.52\text{mm}$$

### 5.2.5 Calculation of manufacturing sizes for machining Ø32s7:

Finding size  $A_{4.3}$ :

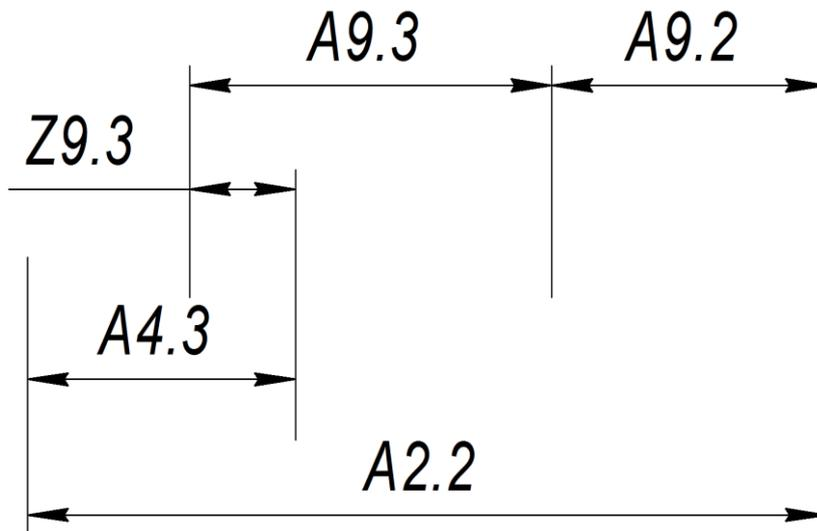

$$Z_{9.3\min} = A_{9.3\min} + A_{9.2\min} + A_{4.3\min} - A_{2.2\max}$$

$$A_{4.3\min} = Z_{9.3\min} - A_{9.3\min} - A_{9.2\min} + A_{2.2\max} = 0.69 - 21 - 10 + 128 = 97.69 \text{ mm}$$

$$A_{4.3\max} = 97.69 + 0.24 = 97.93 \text{ mm}$$

$$A_{4.3\text{accepted}} = 97.93_{-0.24}$$

$$Z_{9.3\max} = A_{9.3\max} + A_{9.2\max} + A_{4.3\max} - A_{2.2\min} = 21.08 + 10.08 + 97.93 - 127.58 = 1.51 \text{ mm}$$

Finding size  $A_{2.4}$ :

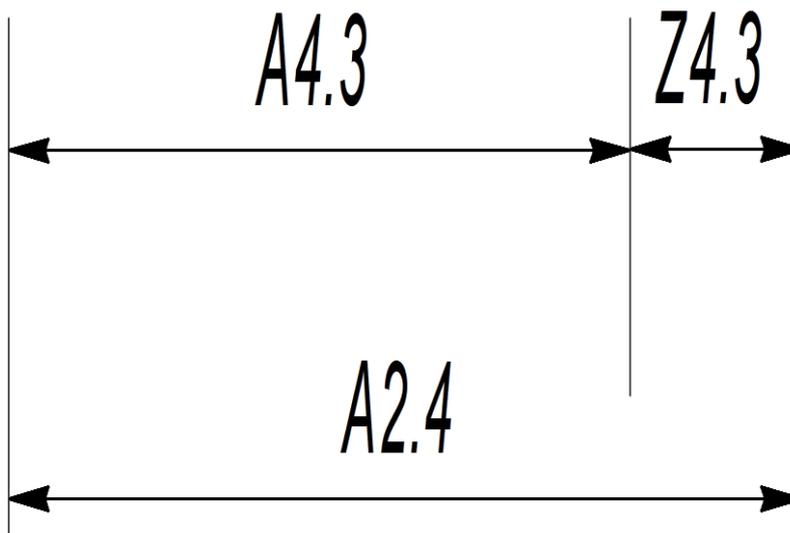

$$Z_{4.3\min} = A_{2.4\min} - A_{4.3\max}$$

$$A_{2.4\min} = Z_{4.3\min} + A_{4.3\max} = 97.93 + 0.58 = 98.51 \text{ mm}$$

$$A_{2.4\max} = 98.51 + 0.42 = 98.93 \text{ mm}$$

$$A_{2.4\text{accepted}} = 98.93_{-0.42}$$

$$Z_{4.3\max} = A_{2.4\max} - A_{4.3\min} = 98.93 - 97.96 = 0.97\text{mm}$$

**Finding initial size  $A_{0.4}$ :**

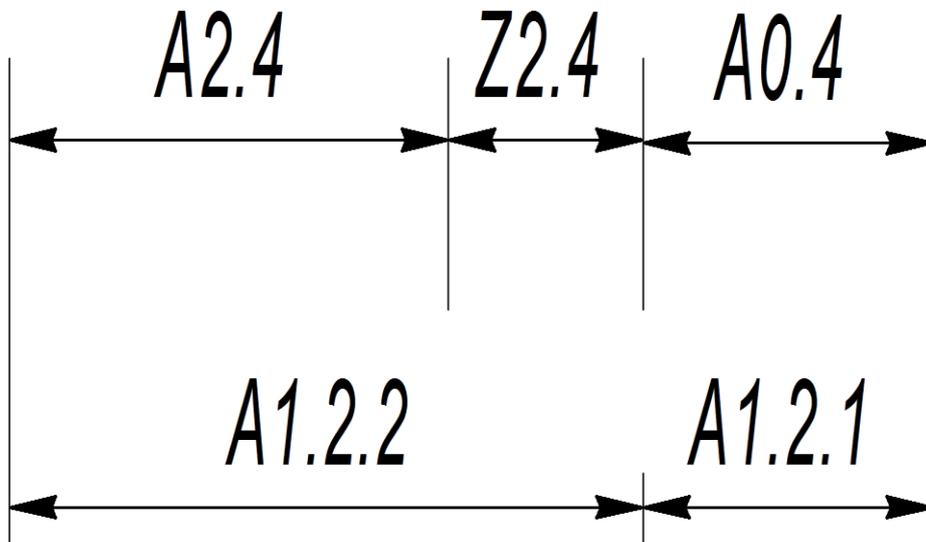

$$Z_{2.4\min} = A_{1.2.2\min} + A_{1.2.1\min} - A_{0.4\max} - A_{2.4\max}$$

$$A_{0.4\max} = A_{1.2.2\min} + A_{1.2.1\min} - Z_{2.4\min} - A_{2.4\max} \\ = 150.8 + 1.75 - 2.7 - 98.93 = 50.92\text{mm}$$

$$A_{0.4\min} = 50.92 - 1.2 = 49.72\text{mm}$$

$$A_{0.4\text{accepted}} = 50.12_{-0.4}^{+0.8}$$

$$Z_{2.4\max} = A_{1.2.2\max} + A_{1.2.1\max} - A_{0.4\min} - A_{2.4\min} = 151 + 2.75 - 49.72 - 98.51 = 5.52\text{mm.}$$

### 5.2.6 Calculation of manufacturing sizes for machining Ø32s7:

Finding size  $A_{5.3}$ :

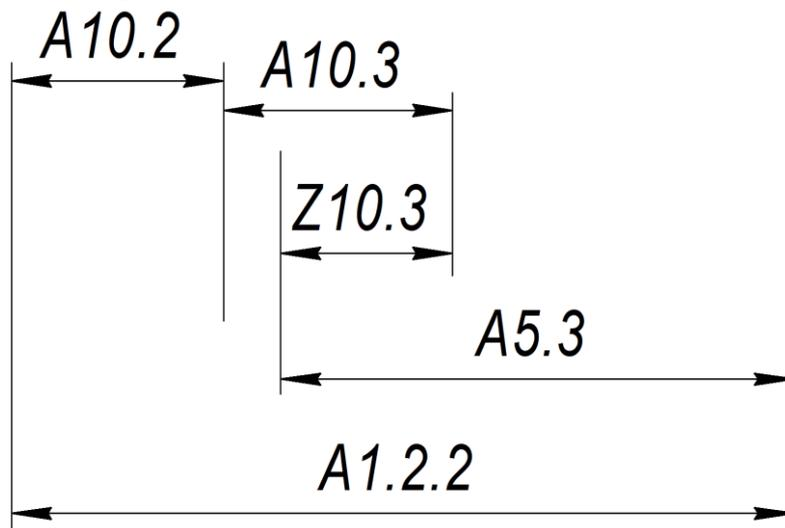

$$Z_{10.3\min} = A_{10.2\min} + A_{10.3\min} + A_{5.3\min} - A_{1.2.2\max}$$

$$A_{5.3\min} = Z_{10.3\min} - A_{10.2\min} - A_{10.3\min} + A_{1.2.2\max} \\ = 0.58 - 23 - 53 + 151 = 75.58\text{mm}$$

$$A_{5.3\max} = 75.58 + 0.24 = 75.82\text{mm}$$

$$A_{5.3\text{accepted}} = 75.82_{-0.24}$$

$$Z_{10.3\max} = A_{10.2\max} + A_{10.3\max} + A_{5.3\max} - A_{1.2.2\min} = 23.08 + 53.08 + 75.82 - 150.8 = 1.18\text{mm}$$

Finding size  $A_{3.3}$ :

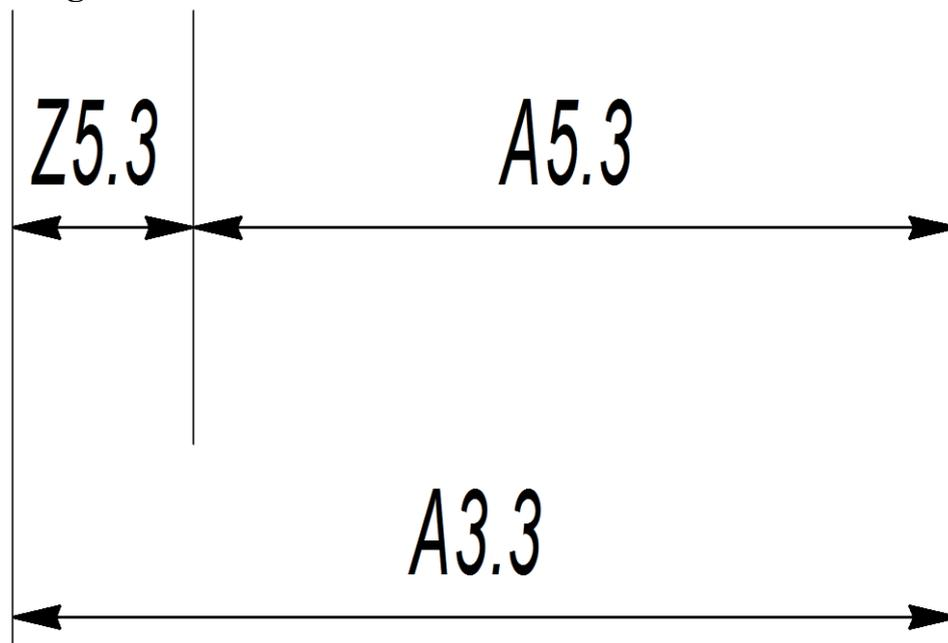

$$Z_{5.3\min} = A_{3.3\min} - A_{5.3\max}$$

$$A_{3.3\min} = Z_{5.3\min} + A_{5.3\max} = 0.58 + 75.82 = 76.4\text{mm}$$

$$A_{3.3\max} = 76.4 + 0.42 = 76.82\text{mm}$$

$$A_{3.3\text{accepted}} = 76.82_{-0.42}$$

$$Z_{5.3\max} = A_{3.3\max} - A_{5.3\min} = 76.82 - 75.58 = 1.24\text{mm}$$

**Finding initial size  $A_{0.6}$ :**

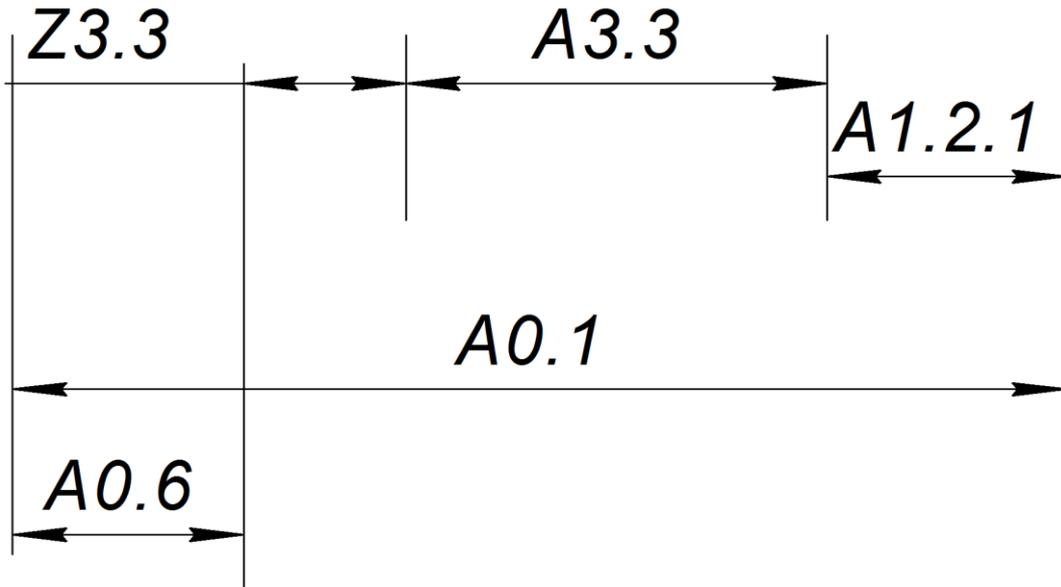

$$Z_{3.3\min} = A_{0.1\min} - A_{3.3\max} - A_{1.2.1\max} - A_{0.6\max}$$

$$A_{0.6\max} = A_{0.1\min} - Z_{3.3\min} - A_{3.3\max} - A_{1.2.1\max} \\ = 155.1 - 0.42 - 76.82 - 2.75 = 75.11\text{mm}$$

$$A_{0.6\min} = 75.11 - 1.2 = 73.9\text{mm}$$

$$A_{0.6\text{accepted}} = 74^{+0.8}_{-0.4}$$

$$Z_{3.3\max} = A_{0.1\max} - A_{3.3\min} - A_{1.2.1\min} - A_{0.6\min} \\ = 156.3 - 76.4 - 1.75 - 73.9 = 4.25\text{mm}$$

**5.2.7 Calculation of manufacturing sizes for machining  $\text{Ø}25\text{n}6$  (left side):**

**Finding size  $A_{5.2}$ :**

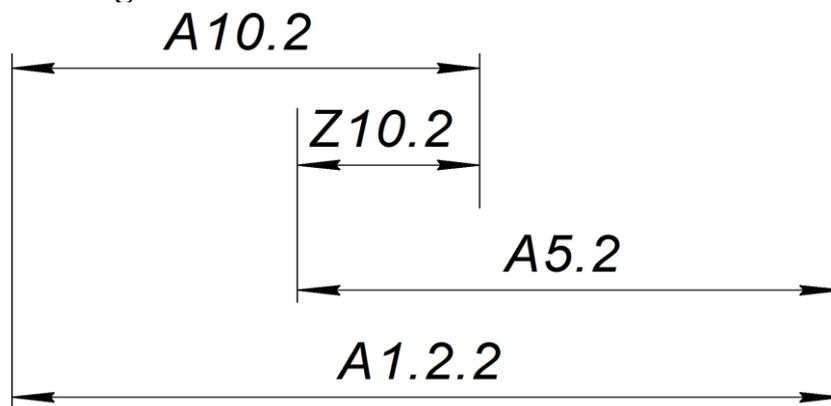

$$Z_{10.2\min} = A_{5.2\min} + A_{10.2\min} - A_{1.2.2\max}$$

$$A_{5.2\min} = Z_{10.2\min} - A_{10.2\min} + A_{1.2.2\max} \\ = 0.69 - 23 + 151 = 128.69\text{mm}$$

$$A_{5.2\max} = 128.69 + 0.24 = 128.93\text{mm}$$

$$A_{5.2\text{accepted}} = 128.93 - 0.24$$

$$Z_{10.2\max} = A_{5.2\max} + A_{10.2\max} - A_{1.2.2\min} = 128.93 + 23.08 - 150.8 = 1.21 \text{ mm}$$

**Finding size  $A_{3.2}$ :**

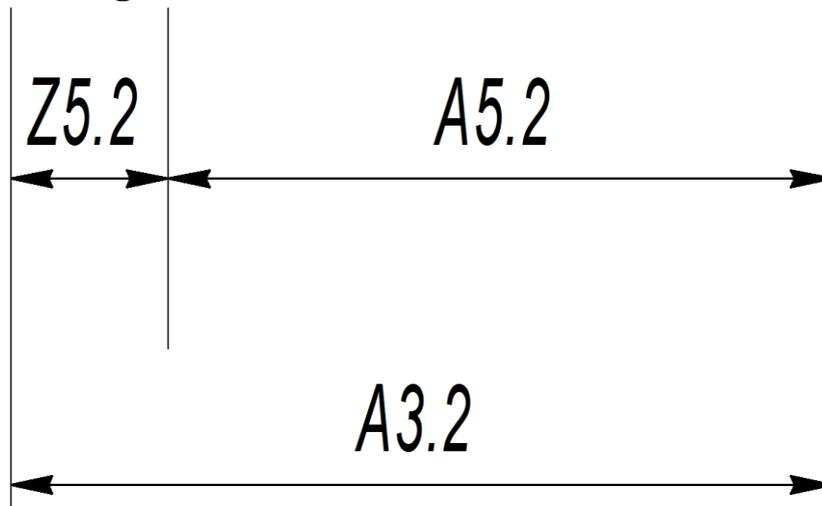

$$Z_{5.2\min} = A_{3.2\min} - A_{5.2\max}$$

$$A_{3.2\min} = Z_{5.2\min} + A_{5.2\max} = 0.69 + 128.93 = 129.62 \text{ mm}$$

$$A_{3.2\max} = 129.62 + 0.42 = 130.04 \approx 130$$

$$A_{3.2\text{accepted}} = 130 - 0.42$$

$$Z_{5.2\max} = A_{3.2\max} - A_{5.2\min} = 130 - 128.69 = 1.31 \text{ mm}$$

**Finding initial size  $A_{0.5}$ :**

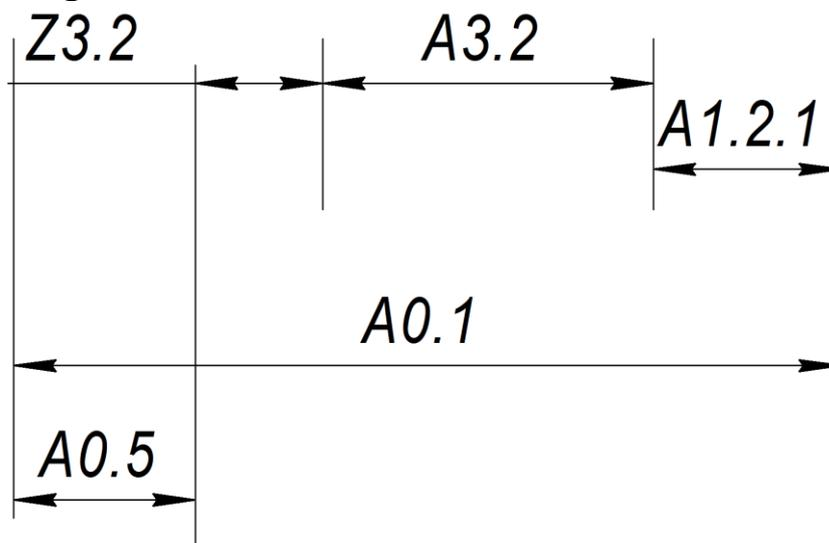

$$Z_{3.2\min} = A_{0.1\min} - A_{3.2\max} - A_{1.2.1\max} - A_{0.5\max}$$

$$A_{0.5\max} = A_{0.1\min} - Z_{3.2\min} - A_{3.2\max} - A_{1.2.1\max} \\ = 155.1 - 2.7 - 130 - 2.75 = 19.65 \text{ mm}$$

$$A_{0.5\min} = 19.65 - 1.2 = 18.45 \text{ mm}$$

$$A_{0.5\text{accepted}} = 18.85^{+0.8}_{-0.4}$$

$$Z_{3.2\max} = A_{0.1\max} - A_{3.2\min} - A_{1.2.1\min} - A_{0.5\min} = 156.3 - 129.62 - 1.75 - 18.45 = 6.48 \text{ mm.}$$

### 5.3 Chamfers manufacturing sizes calculations:

Processing chamfers ensuring its required quality is a hard task, for that reason manufacture engineer should find a way so that the sum of the manufacturing sizes won't be bigger than the designer size and here are the steps using the method of complete interchangeability

#### 5.3.1 Manufacturing size calculations for chamfer A<sub>4.4</sub>:

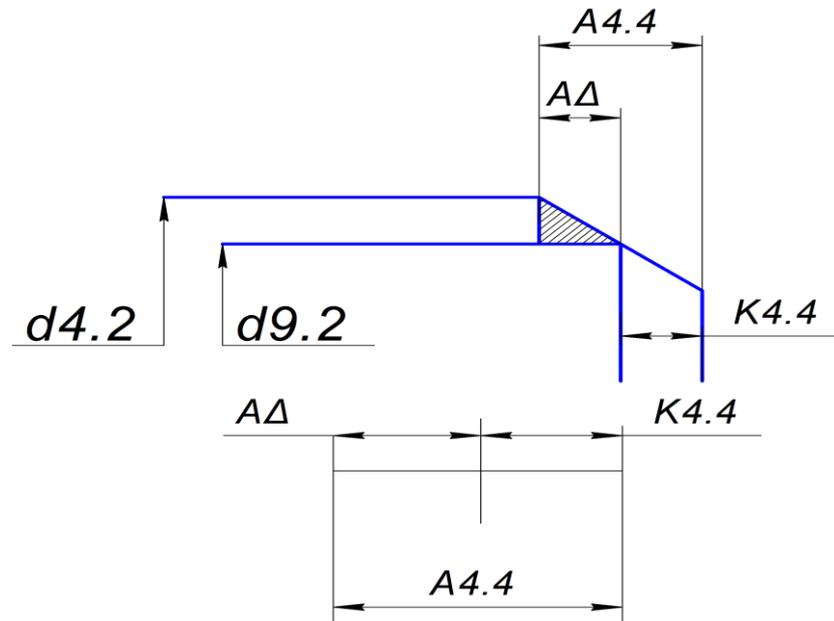

$$K_{4.4} = A_{4.4} - A_{\Delta}$$

$$A_{\Delta} = \frac{d_{4.2} - d_{9.2}}{2} = \frac{25.8_{-0.052} - 25_{+0.015}^{+0.028}}{2} = 12.9_{-0.062} - 12.5_{+0.0075}^{+0.014} =$$

$$0.4_{-0.04}^{-0.0075} \text{ mm}$$

$$TK_{4.4} = TA_{4.4} + TA_{\Delta} = 0.2 + 0.0325 = 0.23 \approx 0.3 \text{ mm}$$

$$K_{4.4} = 2.5 \pm 0.15 \text{ mm} \times 45^{\circ}$$

$$U_{K_{4.4}} = U_{A_{4.4}} - L_{A_{\Delta}};$$

$$+0.15 = U_{A_{4.4}} - (-0.04); U_{A_{4.4}} = 0.15 - 0.04 = +0.11 \text{ mm}$$

$$L_{K_{4.4}} = L_{A_{4.4}} - U_{TA_{\Delta}};$$

$$-0.15 = L_{A_{4.4}} - (-0.0075); L_{A_{4.4}} = -0.15 - 0.0075 = -0.15 \text{ mm}$$

$$A_{4.4} = 2.8_{-0.15}^{+0.11} \text{ mm}$$

### 5.3.2 Manufacturing size calculations for chamfer A<sub>4.5</sub>:

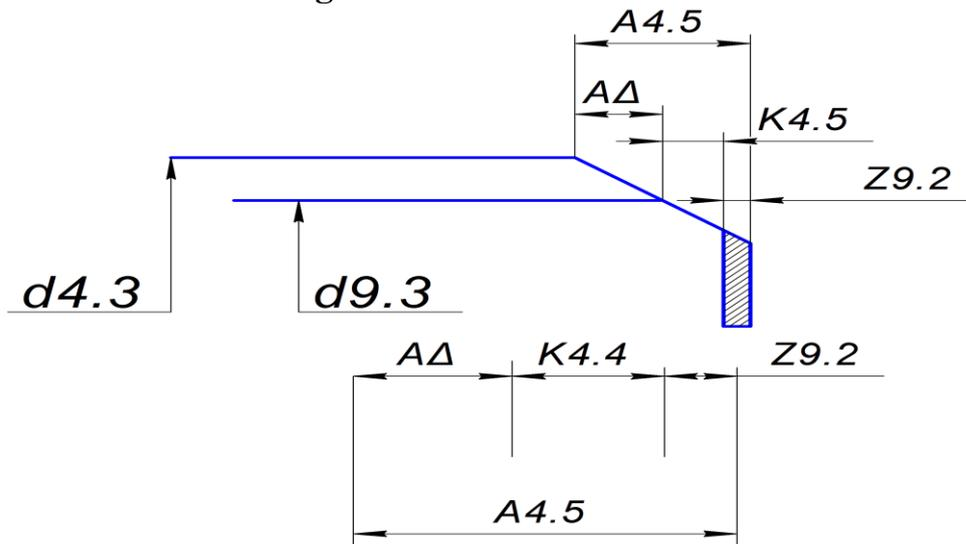

$$K_{4.5} = A_{4.5} - A_{\Delta} - Z_{9.2}$$

$$A_{\Delta} = \frac{d_{4.3} - d_{9.3}}{2} = \frac{32.82_{-0.062} - 32_{+0.043}^{+0.068}}{2} = 16.41_{-0.031} - 16_{+0.0215}^{+0.034} = 0.41_{-0.065}^{+0.0215} \text{ mm}$$

$$TK_{4.5} = TA_{4.5} + TA_{\Delta} + TZ_{9.2} = 0.2 + 0.0435 + 0.74 = 0.98 \approx 1 \text{ mm}$$

$$K_{4.5} = 2.5 \pm 0.5 \text{ mm} \times 45^{\circ}$$

$$U_{K4.5} = U_{A4.5} - L_{A\Delta} - L_{Z9.2};$$

$$+0.5 = U_{A4.5} - (-0.065) - (-0.24); U_{A4.4} = 0.5 - 0.065 - 0.24 = +0.19 \text{ mm}$$

$$L_{K4.5} = L_{A4.5} - U_{TA\Delta} - U_{TZ9.2};$$

$$-0.5 = L_{A4.5} - (-0.0215) - (+0.5); L_{A4.5} = -0.5 - 0.0215 + 0.5 = -0.0215 \text{ mm}$$

$$A_{4.5} = 3.84_{-0.0215}^{+0.19} \text{ mm}$$

### 5.3.3 Manufacturing size calculations for chamfer A<sub>4.6</sub>:

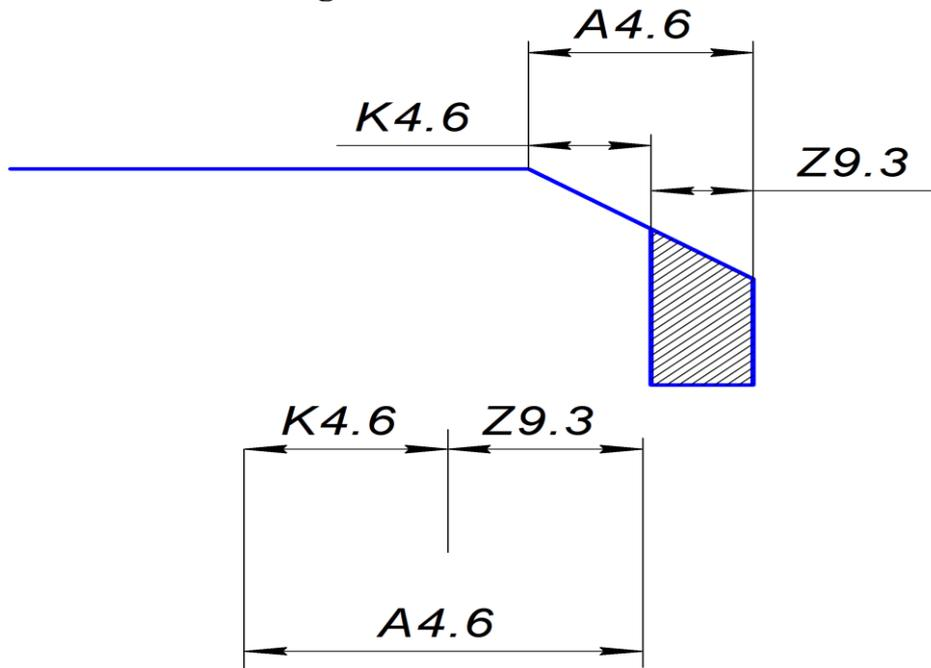

$$K_{4.6} = A_{4.6} - Z_{9.3}$$

$$TK_{4.6} = TA_{4.6} + TZ_{9.3} = 0.2 + 0.82 = 1.02 \approx 1 \text{ mm}$$

$$K_{4.6} = 2.5 \pm 0.5 \text{ mm} \times 45^\circ$$

$$U_{K4.6} = U_{A4.6} - L_{Z9.3};$$

$$+0.5 = U_{A4.6} - (-0.24); U_{A4.6} = 0.5 - 0.24 = +0.26 \text{ mm}$$

$$L_{K4.6} = L_{A4.6} - U_{Z9.3};$$

$$-0.5 = L_{A4.6} - (+0.58); L_{A4.6} = -0.5 + 0.58 = +0.08 \text{ mm}$$

$$A_{4.6} = 3.17^{+0.26}_{+0.08} \text{ mm}$$

### 5.3.4 Manufacturing size calculations for chamfer A<sub>5.6</sub>:

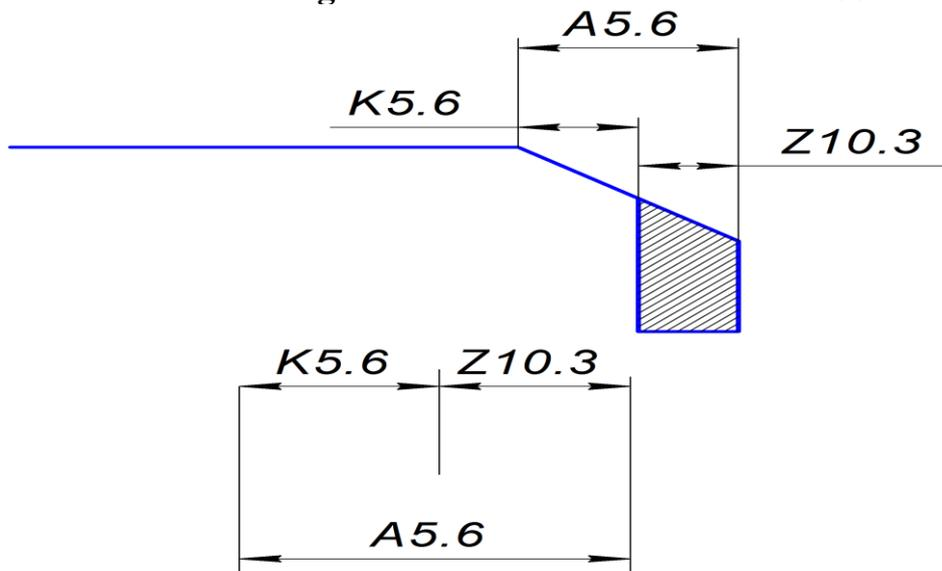

$$K_{5.6} = A_{5.6} - Z_{10.3}$$

$$TK_{5.6} = TA_{5.6} + TZ_{10.3} = 0.2 + 0.6 = 0.8 \text{ mm}$$

$$K_{5.6} = 2.5 \pm 0.4 \text{ mm} \times 45^\circ$$

$$U_{K5.6} = U_{A5.6} - L_{Z10.3};$$

$$+0.4 = U_{A5.6} - (-0.24); U_{A5.6} = 0.4 - 0.24 = +0.16 \text{ mm}$$

$$L_{K5.6} = L_{A5.6} - U_{Z10.3};$$

$$-0.4 = L_{A5.6} - (+0.36); L_{A5.6} = -0.4 + 0.36 = -0.04 \text{ mm}$$

$$A_{5.6} = 3.16_{-0.04}^{+0.16} \text{ mm}$$

### 5.3.5 Manufacturing size calculations for chamfer A<sub>5.5</sub>:

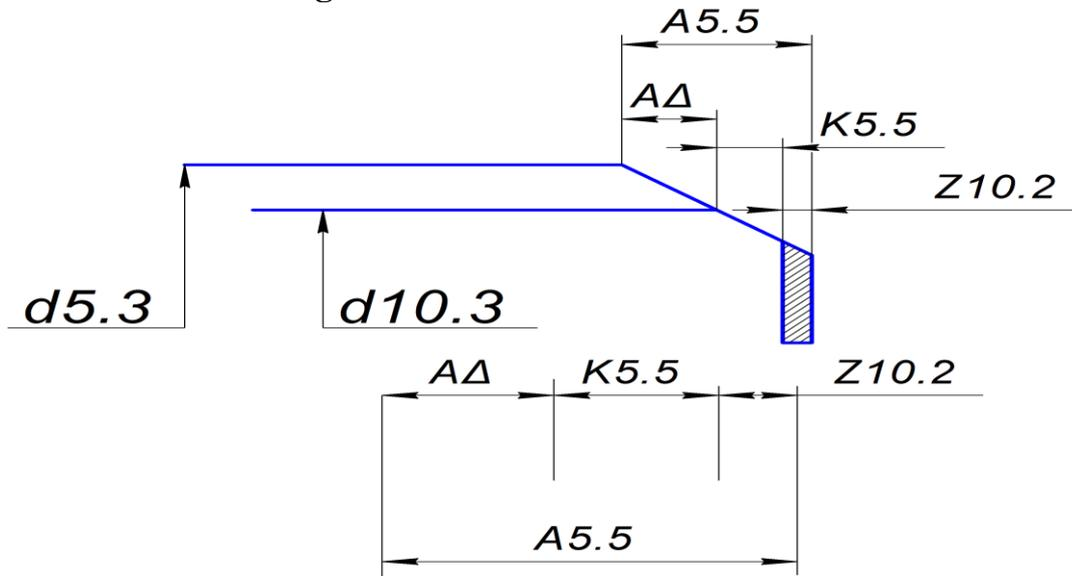

$$K_{5.5} = A_{5.5} - A_{\Delta} - Z_{10.2}$$

$$A_{\Delta} = \frac{d_{5.3} - d_{10.3}}{2} = \frac{32.75_{-0.062} - 32_{-0.025}^{+0.009}}{2} = 16.375_{-0.031} - 16_{-0.0125}^{+0.0045} = 0.375_{-0.0265}^{+0.0125} \text{ mm}$$

$$TK_{5.5} = TA_{5.5} + TA_{\Delta} + TZ_{10.2} = 0.2 + 0.039 + 0.52 = 0.759 \approx 0.76 \text{ mm}$$

$$K_{5.5} = 2.5 \pm 0.38 \text{ mm} \times 45^\circ$$

$$U_{K5.5} = U_{A5.5} - L_{A\Delta} - L_{Z10.2};$$

$$+0.38 = U_{A5.5} - (-0.0265) - (-0.24); U_{A5.5} = 0.38 - 0.0265 - 0.24 = +0.1135 \text{ mm}$$

$$L_{K5.5} = L_{A5.5} - U_{A\Delta} - U_{Z10.2};$$

$$-0.38 = L_{A5.5} - (+0.0125) - (+0.28); L_{A5.5} = -0.38 + 0.0125 + 0.28 = -0.0875 \text{ mm}$$

$$A_{5.5} = 3.7_{-0.0875}^{+0.1135} \text{ mm}$$

## 6. Calculation of cutting modes

Elements of cutting modes are nominated taking into account character of processing, type and sizes of the cutting tool, material of its cutting part, material and surface condition of a blank, type and condition of the equipment.

### 6.1. Calculation of cutting modes for rough turning of surface $\text{Ø}26,6\text{h}12$

**Chosen cutting tool: T15k6;**

**Cutting tool parameters:**  $\varphi = 90^\circ$ ;  $\varphi_1 = 10^\circ$ ;  $r = 2,5\text{mm}$ ;  $\gamma = 10^\circ$

While:  $\varphi$  – main cutting angle;  $\varphi_1$  – auxiliary cutting angle;  $r$  – nose radius;  $\gamma$  – rake angle. Shank size 16×25

**Cutting speed:**

Let's calculate modes of cutting at draft turning of an outside surface of the cartridge  $\text{Ø}26,6\text{h}12$  in the second operation. The size of the processed surface  $d_i = \text{Ø}26,6\text{h}12$ . The size of a processable surface -  $d_{i-1} = \text{Ø}29,7^{+0,8}_{-0,4}$  (diameter of a rod). **Previously** we calculate the greatest depth of cutting  $t_{\max}$ , if we remove all stock on rough (draft) processing for one pass (after 1 stroke):

$$t_{\max} = (d_{(i-1)\max} - d_{i\min})/2 = (29,7+0,8) - (26,6-0,21)/2 = 2,055 \text{ mm.}$$

The greatest depth of cutting is less than 4 mm, and it is possible to remove all stock for one pass. We **accept the greatest depth of cutting**  $t_{\max} = 2,055$  mm. Other elements of a mode of cutting are usually established and calculated in the order which has been mentioned below.

**Feed rate S** is nominated by using machinist handbook [1, tab. 11]. At draft processing, choosing feed rate, it is necessary to check up durability of a cutter shank and carbide cutting plate, rigidity of a processable detail and durability of the feed rate mechanism of the machine tool. Feed rate S is usually limited by nose radius R and roughness of processed surface Ra [1, tab. 14].

We choose a cutter under the recommendations [2, page 438]. A cutter - through passage direct with a cutting plate from cemented carbide T15K6: 2100-01 17-T15K6.

The sizes of the cutter shank are 16×25 mm. On durability shank the large feed rate will sustain at rather small depth of cut  $t=2,055$  mm. Therefore finally we choose feed rate proceeding from a required roughness of a surface for draft processing ( $R_a \leq 10$  microns) and nose radius  $r = 2.5$  mm (at draft processing nose radius can be taken large, since the high accuracy is not required and elastic deformation of a cutter and a detail at the greater force  $P_y$  does not play main role as at finish processing).

**A)** We choose the feed rate  $S_a$  according to the depth of cut  $t=2,055$  mm and

shank size 16×25 mm [tab. 11]  $S_a = 0,5 \text{ mm/r}$ .

**B)** We choose the feed rate  $S_b$  according to insert thickness  $h=4 \text{ mm}$  and depth of cut  $t=2,055 \text{ mm}$  [tab. 13] taking into account ultimate strength coefficient  $\sigma_u = 750 \text{ mPa}$  and main cutting angle  $\varphi = 90^\circ$   $S_b = 1,3 \cdot 1 \cdot 0,4 = 0,52 \text{ mm/r}$ .

**C)** We choose the feed rate  $S_c$  according to roughness of surface  $Rz = 40 \mu\text{m}$  and nose radius  $r = 2,5 \text{ mm}$  [tab. 14] taking into account the ultimate strength coefficient  $\sigma_u = 750 \text{ mPa}$ ,  $S_c = 0,87 \cdot 0,45 \approx 0,4 \text{ mm/r}$ .

Since the high accuracy is not required and elastic deformation of a cutter and a detail at the greater force  $P_y$  does not play main role as at finish processing). We determine feed rate  $S = 0.5 \text{ mmpr}$ .

It is possible to define cutting speed  $V$ , mpm, by several methods:

- 1) Calculation by the formula;
- 2) Using table data with the use of correction factors;
- 3) On the basis of the empirical data (used on the enterprise for the appropriate processable and cutting materials, geometry of the tool etc.)

The cutting speed  $V$ , mpm (meter per minute), is calculated by the formula:

$$V = \frac{C_V}{(T^m \cdot t^x \cdot s^y)} \cdot K_V, \quad (7.1)$$

Where:  $T$  - cutting tool life (period of work of the cutting tool before the wear). At draft processing in mass production it is usually  $T=30 \text{ min}$ . [1, page 6].

The value of factor  $C_V$  and parameters of a degree are given in tab. 17. For considered draft turning of an outside surface we accept that the depth of cut will be equal to the greatest depth of cut:  $t = t_{max} = 2,055 \text{ mm}$ . Factors and parameters of degrees are defined from tab. 17 [1]:

$$C_V=350; x=0.15; y=0.35; m=0.20.$$

$K_V$  - correction factor which takes into account geometry of cutting tool.

$$K_V = K_{Mv} \times K_{tv} \times K_{sv} \times K_{\varphi v} \times K_{\varphi lv} \times K_{Rv} \times K_{Ov}, \quad (7.2)$$

Where  $K_{Mv} = 75/\sigma_e$  - is the factor which is take into account influence of quality of a processable material (durability) on cutting speed. For steel 40X tensile strength (strength of stretching)  $\sigma_e=750 \text{ mPa}$ , therefore  $K_{Mv} = 750/\sigma_e = 750/750 = 1$ ;

$K_{tv}$  - factor taking into account material of a cutting tool. For a cutting plate from a cemented carbide T15K6  $K_{tv} = 1$  [1, tab. 6];

$K_{sv} = 0.8$  - factor taking into account a condition of a surface of blank [1, tab. 5];

$K_{\varphi v} = 0.7$  - factor taking into account geometrical parameters of a cutter (the main angle in the plan  $\varphi$ ); tab. 18

$K_{\varphi 1v} = 1$  - factor taking into account geometrical parameters of a cutter (an auxiliary angle in the plan  $\varphi_1$ );

$K_{rv} = 1$  - factor taking into account geometrical parameters of a cutter (nose radius R of a cutter);

$K_{Ov} = 1$  - factor taking into account kind of processing (outside turning in our case).

$$K_V = 1 \times 1 \times 0.8 \times 0.7 \times 1 \times 1 \times 1 = 0.56.$$

$$V = \frac{C_V}{(T^m \cdot t^x \cdot s^y)} \cdot K_V = \frac{350}{(30^{0.2} \cdot 2.055^{0.15} \cdot 0.5^{0.35})} \cdot 0.56 = 113.57 \text{ mpm.}$$

### Cutting forces:

It is accepted to split the force of cutting P on making (component) forces which are directed on axes of coordinates of the machine tool (Pz, Py, Px).

For outside longitudinal turning:

$$P_{z,y,x} = C_P \times t^x \times s^y \times V^n \times K_P, \quad [\text{N}], \quad (7.3)$$

Where  $C_P$  - factor depending on a processable and cutting material;  $K_P$  - correction factor.

$$K_P = K_{Mp} \times K_{\varphi p} \times K_{\gamma p} \times K_{\lambda p} \times K_{Rp}, \quad (7.4)$$

Where  $K_{Mp}$  - factor taking into account influence of quality of a processable material (durability) on force of cutting. For steel 40X strength on a stretching is  $\sigma_s = 750 \text{ mPa}$ , therefore  $K_{Mp} = 1$  [1, tab. 21];

$K_{\varphi p}$  - factor taking into account influence of the main angle in the plan  $\varphi$  on a force of cutting [1, tab. 23];

$K_{\gamma p}$  - factor taking into account influence of the main forward angle in main cross-section plane  $\gamma$  (rake angle) on force of cutting;

$K_{\lambda p}$  - factor taking into account influence of an inclination main cutting edge angle  $\lambda$  on force of cutting;

$K_{Rp}$  - factor taking into account influence of cutter nose radius R on force of cutting;

For considered draft turning of an outside surface  $\varnothing 26,6h12$  in the second operation we accept that depth of cut  $t$  will be equal to the greatest depth of cut  $t_{max}$ :  $t = t_{max} = 2.055 \text{ mm}$ . Factors and parameters of degrees found in tab. 9,10,22,23, [1] we write in tab. 7.1.

Table 7.1. Calculation of cutting component forces at rough turning  $\text{Ø}26,6h12$

Compo- nents	$C_P$	$x$	$y$	$n$	$K_{Mp}$	$K_{\phi p}$	$K_{\gamma p}$	$K_{\lambda p}$	$K_{Rp}$	$K_P$	$P_{z,y,x}$ , N
$P_z$	300	1	0.75	- 0.15	1	0.89	1	1	1	0.89	1604,2
$P_y$	243	0.9	0.6	-0.3	1	0.5	1	1	1	0.5	370,6
$P_x$	339	1	0.5	-0.4	1	1.17	1	1	1	1,17	868,1

$$P_z = 10 \times 300 \times 2,055^1 \times 0,5^{0.75} \times 113,57^{-0.15} \times 0,89 = 1604,2 \text{ N};$$

$$P_y = 10 \times 243 \times 2,055^{0.9} \times 0,5^{0.6} \times 113,57^{-0.3} \times 0,5 = 370,6 \text{ N};$$

$$P_x = 10 \times 339 \times 2,055^1 \times 0,5^{0.5} \times 113,57^{-0.4} \times 1,17 = 868,1 \text{ N};$$

### Cutting Power:

The *cutting power* is calculated by the formula:

$$N = \frac{P_z \cdot V}{1020 \cdot 60}, [\text{kW}] \quad (7.5)$$

Where  $P_z$  - tangential component of cutting force (conterminous on a direction with a vector of cutting speed), N;  $V$  - cutting speed, mpm.

In our case at rough turning of an outside surface  $\text{Ø}30.8h11$ :

$$N = \frac{1604,2 \cdot 113,57}{1020 \cdot 60} = 2,97 \text{ kW}.$$

We calculate number of revolutions of a spindle per 1 minute  $n_{cal}$ :

$$n_{cal} = \frac{1000 \cdot V}{\pi \cdot d_{max}} = \frac{1000 \cdot 113,57}{\pi \cdot 29,7} = 1217 \text{ rpm}$$

Where:  $d_{max}$  - greatest diameter of a processable surface, mm.

In the technical passport of the machine tool we find the nearest smaller number of revolutions of a spindle (smaller - since even at insignificant increasing of cutting speed can result an essential reduction of cutting tool life  $T$ ):  $n_{pas} = 1000 \text{ rev/min}$ . We calculate the *real* (specified or corrected) *cutting speed* at the accepted number of revolutions of a spindle:

$$V = \frac{\pi \cdot d \cdot n_{pas}}{1000}, \text{ mpm.} \quad (7.6)$$

In our case the real speed of cutting  $N_r$ :

$$V_o = \frac{\pi \cdot 29,7 \cdot 1000}{1000} = 93,3 \text{ mpm.}$$

**Specified (real) power of cutting  $N_r$ :**

$$N_r = \frac{1604,2 \cdot 93,3}{1020 \cdot 60} = 2,4 \text{ kW.}$$

**Machining time:**

$$Mt = \frac{l}{s \cdot n} = \frac{17,5}{0,5 \cdot 1000} = 0,035$$

## 6.2. Calculation of cutting modes for semi-finish turning of surface $\text{Ø}25,8h9$

**Chosen cutting tool: T15k6;**

Cutting tool parameters:  $\varphi = 90^\circ$ ;  $\varphi_1 = 10^\circ$ ;  $r = 0,8 \text{ mm}$ ;  $\gamma = 10^\circ$

While:  $\varphi$  – main cutting angle;  $\varphi_1$  – auxiliary cutting angle;  $r$  – nose radius;  $\gamma$  – rake angle. Shank size  $16 \times 25$

**Cutting Speed:**

The size of the processed surface  $d_i = 25,8h9$ . The size of a processable surface -  $d_{i-1} = \text{Ø}26,6h12$  (diameter of a rod).

We calculate the greatest depth of cutting  $t_{\max}$ , if we remove all stock on rough (draft) processing for one pass (after 1 stroke):

$$t_{\max} = (d_{(i-1)\max} - d_{i\min})/2 = (26,6) - (25,8 - 0,052)/2 = 0,426 \text{ mm.}$$

Cutting tool life for semi finish **T = 15 min**

Feed rate  $S_a = 0,4 \text{ mm/r}$ ;  $S_b = 1,3 \cdot 1 \cdot 0,4 = 0,52 \text{ mm/r}$ ;  $S_c = 0,20 \cdot 0,45 = 0,09 \text{ mm/r}$ , accepted feed rate **S = 0,07 mm/r**

**The cutting speed V**, mpm (meter per minute), is calculated by the formula:

$$V = \frac{C_V}{(T^m \cdot t^x \cdot s^y)} \cdot K_V,$$

The value of factor  $C_V$  and parameters of a degree are given in tab. 17. For considered draft turning of an outside surface we accept that the depth of cut will be equal to the greatest depth of cut:  $t = t_{\max} = 0,426 \text{ mm}$ . Factors and parameters of degrees are defined from tab. 17 [1]:

$$C_V = 420; x = 0,15; y = 0,20; m = 0,20.$$

$K_V$  - correction factor which takes into account geometry of cutting tool.

$$K_V = K_{Mv} \times K_{tv} \times K_{sv} \times K_{\phi v} \times K_{\phi lv} \times K_{rv} \times K_{Ov}, \quad (7.2)$$

Where  $K_{Mv} = 1$

$$K_{tv} = 1$$

$$K_{sv} = 1$$

$$K_{\phi v} = 0,7$$

$$K_{\phi lv} = 1$$

$$K_{rv} = 0,94$$

$$K_{Ov} = 1$$

$$K_V = 1 \times 1 \times 1 \times 0,7 \times 1 \times 0,94 \times 1 = 0,658.$$

$$V = \frac{C_V}{(T^m \cdot t^x \cdot s^y)} \cdot K_V = \frac{420}{(15^{0.20} \cdot 0.426^{0.15} \cdot 0.07^{0.20})} \cdot 0.658 = 311 \text{ mpm.}$$

### Cutting Forces:

It is accepted to split the force of cutting P on making (component) forces which are directed on axes of coordinates of the machine tool (Pz, Py, Px).

For outside longitudinal turning:

$$P_{z,y,x} = C_P \times t^x \times s^y \times V^n \times K_P, \text{ [N]},$$

$$K_P = K_{Mp} \times K_{\phi p} \times K_{\gamma p} \times K_{\lambda p} \times K_{Rp}, \quad (7.4)$$

Table 7.1. Calculation of cutting component forces at rough turning **Ø25,8h9**

Compo- nents	$C_P$	$x$	$y$	$n$	$K_{Mp}$	$K_{\phi p}$	$K_{\gamma p}$	$K_{\lambda p}$	$K_{Rp}$	$K_P$	$P_{z,y,x}$ , N
$P_z$	300	1	0.75	- 0.15	1	0.89	1	1	1	0.89	65.4
$P_y$	243	0.9	0.6	-0.3	1	0.50	1	1	1	0.5	20.4
$P_x$	339	1	0.5	-0.4	1	1.17	1	1	1	1,17	45

$$P_z = 10 \times 300 \times 0,426^1 \times 0,07^{0.75} \times 311^{-0.15} \times 0,89 = 65.4 \text{ N};$$

$$P_y = 10 \times 243 \times 0,426^{0.9} \times 0,07^{0.6} \times 311^{-0.3} \times 0,5 = 20.4 \text{ N};$$

$$P_x = 10 \times 339 \times 0,426^1 \times 0,07^{0.5} \times 311^{-0.4} \times 1,17 = 45 \text{ N};$$

### Cutting Power:

$$N = \frac{P_z \cdot V}{1020 \cdot 60}, [\text{kW}] \quad (7.5)$$

Where  $P_z$  - tangential component of cutting force (conterminous on a direction with a vector of cutting speed), N;  $V$  - cutting speed, mpm.

In our case at semi-finish turning of an outside surface **Ø25,8h9**:

$$N = \frac{65.4 \cdot 311}{1020 \cdot 60} = 0.33 \text{ kW.}$$

We calculate number of revolutions of a spindle per 1 minute  $n_{cal}$ :

$$n_{cal} = \frac{1000 \cdot V}{\pi \cdot d_{max}} = \frac{1000 \cdot 311}{\pi \cdot 26.6} = 3721 \text{ rpm}$$

The real speed of cutting  $N_r$ :

$$V_o = \frac{\pi \cdot 26.6 \cdot 4000}{1000} = 334.2 \text{ mpm.}$$

**Specified (real) power of cutting  $N_r$ :**

$$N_r = \frac{65.4 \cdot 334.2}{1020 \cdot 60} = 0.35 \text{ kW.}$$

**Machining time:**

$$Mt = \frac{l}{s \cdot n} = \frac{14.8}{0.07 \cdot 4000} = 0.052$$

### 6.3. Calculation of cutting modes for rough turning Ø12h14

**Chosen cutting tool: T15k6;**

**Cutting tool parameters:**  $\varphi = 90^\circ$ ;  $\varphi_1 = 10^\circ$ ;  $r = 2,5\text{mm}$ ;  $\gamma = 10^\circ$

While:  $\varphi$  – main cutting angle;  $\varphi_1$  – auxiliariy cutting angle;  $r$  – nose radius;  $\gamma$  – rake angle. Shank size 16×25

### Cutting speed:

The size of the processed surface  $d_i = \text{Ø}12h14$ . The size of a processable surface -  $d_{i-1} = \text{Ø}15_{-0,4}^{+0,8}$  (diameter of a rod). *Previously* we calculate the greatest depth of cutting  $t_{max}$ , if we remove all stock on rough (draft) processing for one pass (after 1 stroke):

$$t_{max} = (d_{(i-1) max} - d_{i min})/2 = (15+0,8) - (12-0,43)/2 = 2,115$$

We accept the greatest depth of cutting  $t_{max} = 2.115$  mm.

Cutting tool life for rough turning **T = 15 min.**

Feed rate  $S_a = 0,4$  mm/r ;  $S_b = 1,3 \cdot 1 \cdot 0,4 = 0,52$  mm/r ;  $S_c = 0,87 \cdot 0,45 \approx 0,4$  mm/r., accepted feed rate **S = 0,43 mm/r**

**The cutting speed V**, mpm (meter per minute), is calculated by the formula:

$$V = \frac{C_V}{(T^m \cdot t^x \cdot s^y)} \cdot K_V,$$

The value of factor  $C_V$  and parameters of a degree are given in tab. 17. For considered draft turning of an outside surface we accept that the depth of cut will be equal to the greatest depth of cut:  $t = t_{max} = 2.115$  mm. Factors and parameters of degrees are defined from tab. 17 [1]:

$$C_V=350; x=0.15; y=0.35; m=0.20.$$

$K_V$  - correction factor which takes into account geometry of cutting tool.

$$K_V = K_{Mv} \times K_{tv} \times K_{sv} \times K_{\phi v} \times K_{\phi lv} \times K_{rv} \times K_{Ov}, \quad (7.2)$$

Where  $K_{Mv} = 1$

$$K_{tv} = 1$$

$$K_{sv} = 0.8$$

$$K_{\phi v} = 0,7$$

$$K_{\phi lv} = 1$$

$$K_{rv} = 1$$

$$K_{Ov} = 1$$

$$K_V = 1 \times 1 \times 0.8 \times 0.7 \times 1 \times 1 \times 1 = 0.56.$$

$$V = \frac{C_V}{(T^m \cdot t^x \cdot s^y)} \cdot K_V = \frac{350}{(30^{0.20} \cdot 2.115^{0.15} \cdot 0.43^{0.35})} \cdot 0.56 = 119.21 \text{ mpm.}$$

### Cutting forces:

It is accepted to split the force of cutting  $P$  on making (component) forces which are directed on axes of coordinates of the machine tool ( $P_z$ ,  $P_y$ ,  $P_x$ ).

For outside longitudinal turning:

$$P_{z,y,x} = C_P \times t^x \times s^y \times V^n \times K_P, \text{ [N]},$$

$$K_P = K_{M_p} \times K_{\phi_p} \times K_{\gamma_p} \times K_{\lambda_p} \times K_{R_p}, \quad (7.4)$$

Table 7.1. Calculation of cutting component forces at rough turning  $\varnothing 12h14$

Components	$C_P$	$x$	$y$	$n$	$K_{M_p}$	$K_{\phi_p}$	$K_{\gamma_p}$	$K_{\lambda_p}$	$K_{R_p}$	$K_P$	$P_{z,y,x}$ , N
$P_z$	300	1	0.75	- 0.15	1	0.89	1	1	1	0.89	1463.7
$P_y$	243	0.9	0.6	-0.3	1	0.50	1	1	1	0.5	370,6
$P_x$	339	1	0.5	-0.4	1	1.17	1	1	1	1,17	812.65

$$P_z = 10 \times 300 \times 2.115^1 \times 0.43^{0.75} \times 119.21^{-0.15} \times 0.89 = 1463.7 \text{ N};$$

$$P_y = 10 \times 243 \times 2.115^{0.9} \times 0.43^{0.6} \times 119.21^{-0.3} \times 0.5 = 342.4 \text{ N};$$

$$P_x = 10 \times 339 \times 2.115^1 \times 0.43^{0.5} \times 119.21^{-0.4} \times 1.17 = 812.65 \text{ N};$$

### Cutting Power:

$$N = \frac{P_z \cdot V}{1020 \cdot 60}, \text{ [kW]} \quad (7.5)$$

Where  $P_z$  - tangential component of cutting force (conterminous on a direction with a vector of cutting speed), N;  $V$  - cutting speed, mpm.

In our case at semi-finish turning of an outside surface  $\varnothing 12h14$ :

$$N = \frac{1463.7 \cdot 119.21}{1020 \cdot 60} = 2.85 \text{ kW}.$$

We calculate number of revolutions of a spindle per 1 minute  $n_{cal}$ :

$$n_{cal} = \frac{1000 \cdot V}{\pi \cdot d_{max}} = \frac{1000 \cdot 119.21}{\pi \cdot 15.9} = 2386 \text{ rpm}$$

The real speed of cutting  $N_r$ :

$$V_o = \frac{\pi \cdot 15.9 \cdot 2300}{1000} = 114.8 \text{ mpm.}$$

**Specified (real) power of cutting  $N_r$ :**

$$N_r = \frac{1463.7 \cdot 114.8}{1020 \cdot 60} = 2.7 \text{ kW.}$$

**Machining time:**

$$Mt = \frac{l}{s \cdot n} = \frac{21}{0.43 \cdot 2300} = 0.021$$

#### 6.4. Calculation of cutting modes for rough turning Ø33.65h12

**Chosen cutting tool: T15k6;**

**Cutting tool parameters:**  $\varphi = 90^\circ$ ;  $\varphi_1 = 10^\circ$ ;  $r = 2.5 \text{ mm}$ ;  $\gamma = 10^\circ$

While:  $\varphi$  – main cutting angle;  $\varphi_1$  – auxiliary cutting angle;  $r$  – nose radius;  $\gamma$  – rake angle. Shank size 16×25

**Cutting speed:**

The size of the processed surface  $d_i = \text{Ø}33.65h12$ . The size of a processable surface -  $d_{i-1} = \text{Ø}36.75_{-0.4}^{+0.8}$  (diameter of a rod). **Previously** we calculate the greatest depth of cutting  $t_{max}$ , if we remove all stock on rough (draft) processing for one pass (after 1 stroke):

$$t_{max} = (d_{(i-1) max} - d_{i min})/2 = (36.75+0.8) - (33.65-0.25)/2 = 2.075 \text{ mm}$$

**We accept the greatest depth of cutting  $t_{max} = 2.075$  mm.**

**Cutting tool life for rough turning  $T = 30$  min.**

Feed rate  $S_a = 0.4 \text{ mm/r}$ ;  $S_b = 1.3 \cdot 1 \cdot 0.4 = 0.52 \text{ mm/r}$ ;  $S_c = 0.87 \cdot 0.45 \approx 0.4 \text{ mm/r}$ , accepted feed rate  **$S = 0.43 \text{ mm/r}$**

**The cutting speed  $V$ , mpm (meter per minute), is calculated by the formula:**

$$V = \frac{C_V}{(T^m \cdot t^x \cdot s^y)} \cdot K_V,$$

The value of factor  $C_V$  and parameters of a degree are given in tab. 17. For considered draft turning of an outside surface we accept that the depth of cut will be equal to the greatest depth of cut:  $t = t_{max} = 2.075$  mm. Factors and parameters of degrees are defined from tab. 17 [1]:

$$C_V=350; x=0.15; y=0.35; m=0.20.$$

$K_V$  - correction factor which takes into account geometry of cutting tool.

$$K_V = K_{Mv} \times K_{tv} \times K_{sv} \times K_{\phi v} \times K_{\phi lv} \times K_{rv} \times K_{Ov}, \quad (7.2)$$

Where  $K_{Mv} = 1$

$$K_{tv} = 1$$

$$K_{sv} = 0.8$$

$$K_{\phi v} = 0.7$$

$$K_{\phi lv} = 1$$

$$K_{rv} = 1$$

$$K_{Ov} = 1$$

$$K_V = 1 \times 1 \times 0.8 \times 0.7 \times 1 \times 1 \times 1 = 0.56.$$

$$V = \frac{C_V}{(T^m \cdot t^x \cdot s^y)} \cdot K_V = \frac{350}{(30^{0.20} \cdot 2.075^{0.15} \cdot 0.43^{0.35})} \cdot 0.56 = 119.55 \text{ mpm.}$$

### Cutting forces:

It is accepted to split the force of cutting  $P$  on making (component) forces which are directed on axes of coordinates of the machine tool ( $P_z$ ,  $P_y$ ,  $P_x$ ).

For outside longitudinal turning:

$$P_{z,y,x} = C_P \times t^x \times s^y \times V^n \times K_P, \text{ [N]},$$

$$K_P = K_{Mp} \times K_{\phi p} \times K_{\gamma p} \times K_{\lambda p} \times K_{Rp}, \quad (7.4)$$

Table 7.1. Calculation of cutting component forces at rough turning  $\text{Ø}33.65h12$

Compo- nents	$C_P$	$x$	$y$	$n$	$K_{Mp}$	$K_{\phi p}$	$K_{\gamma p}$	$K_{\lambda p}$	$K_{Rp}$	$K_P$	$P_{z,y,x}$ , N
$P_z$	300	1	0.75	- 0.15	1	0.89	1	1	1	0.89	1435.4
$P_y$	243	0.9	0.6	-0.3	1	0.50	1	1	1	0.5	336.3
$P_x$	339	1	0.5	-0.4	1	1.17	1	1	1	1,17	796.3

$$P_z = 10 \times 300 \times 2.075^1 \times 0.43^{0.75} \times 119.55^{-0.15} \times 0.89 = 1435.4 \text{ N};$$

$$P_y = 10 \times 243 \times 2.075^{0.9} \times 0.43^{0.6} \times 119.55^{-0.3} \times 0.5 = 336.3 \text{ N};$$

$$P_x = 10 \times 339 \times 2.075^1 \times 0.43^{0.5} \times 119.55^{-0.4} \times 1.17 = 796.3 \text{ N};$$

### Cutting Power:

$$N = \frac{P_z \cdot V}{1020 \cdot 60}, [\text{kW}] \quad (7.5)$$

Where  $P_z$  - tangential component of cutting force (conterminous on a direction with a vector of cutting speed), N;  $V$  - cutting speed, mpm.

In our case at rough turning of an outside surface **Ø33.65h12**:

$$N = \frac{1435.4 \cdot 119.55}{1020 \cdot 60} = 2.80 \text{ kW}.$$

We calculate number of revolutions of a spindle per 1 minute  $n_{cal}$ :

$$n_{cal} = \frac{1000 \cdot V}{\pi \cdot d_{max}} = \frac{1000 \cdot 119.55}{\pi \cdot 37.55} = 1013 \text{ rpm}$$

The real speed of cutting  $N_r$ :

$$V_o = \frac{\pi \cdot 37.55 \cdot 1000}{1000} = 117.9 \text{ mpm}.$$

**Specified (real) power of cutting  $N_r$ :**

$$N_r = \frac{1435.4 \cdot 117.9}{1020 \cdot 60} = 2.7 \text{ kW}.$$

**Machining time:**

$$Mt = \frac{l}{s \cdot n} = \frac{20.62}{0.43 \cdot 1000} = 0.047$$

## 6.5. Calculation of cutting modes for semi-finish turning Ø32.82h9

**Chosen cutting tool: T15k6;**

Cutting tool parameters:  $\varphi = 90^\circ$ ;  $\varphi_1 = 10^\circ$ ;  $r = 0,8 \text{ mm}$ ;  $\gamma = 10^\circ$

While:  $\varphi$  – main cutting angle;  $\varphi_1$  – auxiliary cutting angle;  $r$  – nose radius;  $\gamma$  – rake angle. Shank size 16×25

**Cutting Speed:**

The size of the processed surface  $d_i = 32.82h9$ . The size of a processable surface –  $d_{i-1} = \text{Ø}33.65h12$  (diameter of a rod).

We calculate the greatest depth of cutting  $t_{\max}$ , if we remove all stock on rough (draft) processing for one pass (after 1 stroke):

$$t_{\max} = (d_{(i-1)\max} - d_{i\min})/2 = (33.65) - (32.82 - 0,062)/2 = \mathbf{0,446 \text{ mm.}}$$

Cutting tool life for semi finish **T = 15 min**

Feed rate  $S_a = 0,4 \text{ mm/r}$ ;  $S_b = 1,3 \cdot 1 \cdot 0,4 = 0,52 \text{ mm/r}$ ;  $S_c = 0,20 \cdot 0,45 = 0,09 \text{ mm/r}$ , accepted feed rate **S = 0,07 mm/r**

**The cutting speed V**, mpm (meter per minute), is calculated by the formula:

$$V = \frac{C_V}{(T^m \cdot t^x \cdot S^y)} \cdot K_V,$$

The value of factor  $C_V$  and parameters of a degree are given in tab. 17. For considered draft turning of an outside surface we accept that the depth of cut will be equal to the greatest depth of cut:  $t = t_{\max} = 0,321 \text{ mm}$ . Factors and parameters of degrees are defined from tab. 17 [1]:

$$C_V = 420; x = 0.15; y = 0.20; m = 0.20.$$

$K_V$  - correction factor which takes into account geometry of cutting tool.

$$K_V = K_{Mv} \times K_{tv} \times K_{sv} \times K_{\varphi v} \times K_{\varphi 1v} \times K_{rv} \times K_{Ov}, \quad (7.2)$$

Where  $K_{Mv} = 1$

$$K_{tv} = 1$$

$$K_{sv} = 1$$

$$K_{\varphi v} = 0.7$$

$$K_{\varphi 1v} = 1$$

$$K_{rv} = 0,94$$

$$K_{Ov} = 1$$

$$K_V = 1 \times 1 \times 1 \times 0,7 \times 1 \times 0,94 \times 1 = 0,658.$$

$$V = \frac{C_V}{(T^m \cdot t^x \cdot s^y)} \cdot K_V = \frac{420}{(15^{0.20} \cdot 0.446^{0.15} \cdot 0.07^{0.20})} \cdot 0.658 = 308.9 \text{ mpm.}$$

### Cutting Forces:

It is accepted to split the force of cutting P on making (component) forces which are directed on axes of coordinates of the machine tool (Pz, Py, Px).

For outside longitudinal turning:

$$P_{z,y,x} = C_P \times t^x \times s^y \times V^n \times K_P, \text{ [N]},$$

$$K_P = K_{Mp} \times K_{\phi p} \times K_{\gamma p} \times K_{\lambda p} \times K_{Rp}, \quad (7.4)$$

Table 7.1. Calculation of cutting component forces at rough turning **Ø32.82h9**

Compo- nents	$C_P$	$x$	$y$	$n$	$K_{Mp}$	$K_{\phi p}$	$K_{\gamma p}$	$K_{\lambda p}$	$K_{Rp}$	$K_P$	$P_{z,y,x}$ , N
$P_z$	300	1	0.75	- 0.15	1	0.89	1	1	1	0.89	68.56
$P_y$	243	0.9	0.6	-0.3	1	0.50	1	1	1	0.5	21.3
$P_x$	339	1	0.5	-0.4	1	1.17	1	1	1	1,17	42.2

$$P_z = 10 \times 300 \times 0,446^1 \times 0,07^{0.75} \times 308.9^{-0.15} \times 0,89 = 68.56 \text{ N};$$

$$P_y = 10 \times 243 \times 0,446^{0.9} \times 0.07^{0.6} \times 308.9^{-0.3} \times 0.5 = 21.3 \text{ N};$$

$$P_x = 10 \times 339 \times 0,446^1 \times 0.07^{0.5} \times 308.9^{-0.4} \times 1.17 = 42.2 \text{ N};$$

### Cutting Power:

$$N = \frac{P_z \cdot V}{1020 \cdot 60}, \text{ [kW]} \quad (7.5)$$

Where  $P_z$  - tangential component of cutting force (conterminous on a direction with a vector of cutting speed), N;  $V$  - cutting speed, mpm.

In our case at semi-finish turning of an outside surface **Ø32.82h9**:

$$N = \frac{68.56 \cdot 308.9}{1020 \cdot 60} = 0.34 \text{ kW.}$$

We calculate number of revolutions of a spindle per 1 minute  $n_{cal}$ :

$$n_{cal} = \frac{1000 \cdot V}{\pi \cdot d_{max}} = \frac{1000 \cdot 308.9}{\pi \cdot 33.65} = 2922 \text{ rpm}$$

The real speed of cutting  $N_r$ :

$$V_o = \frac{\pi \cdot 33.65 \cdot 3000}{1000} = 317.14 \text{ mpm.}$$

**Specified (real) power of cutting  $N_r$ :**

$$N_r = \frac{68.56 \cdot 317.14}{1020 \cdot 60} = 0.35 \text{ kW.}$$

## 6.6. Calculation of cutting modes for rough turning Ø33.58h12

**Chosen cutting tool: T15k6;**

**Cutting tool parameters:**  $\varphi = 90^\circ$ ;  $\varphi_1 = 10^\circ$ ;  $r = 2,5\text{mm}$ ;  $\gamma = 10^\circ$

While:  $\varphi$  – main cutting angle;  $\varphi_1$  – auxiliary cutting angle;  $r$  – nose radius;  $\gamma$  – rake angle. Shank size 16×25

**Cutting speed:**

The size of the processed surface  $d_i = \text{Ø}33.58\text{h}12$ . The size of a processable surface -  $d_{i-1} = \text{Ø}36.68_{-0,4}^{+0,8}$  (diameter of a rod). **Previously** we calculate the greatest depth of cutting  $t_{\max}$ , if we remove all stock on rough (draft) processing for one pass (after 1 stroke):

$$t_{\max} = (d_{(i-1)\max} - d_{i\min})/2 = (36.68+0,8) - (33.58-0.25)/2 = 2.075 \text{ mm}$$

**We accept the greatest depth of cutting  $t_{\max} = 2.075$  mm.**

**Cutting tool life for rough turning  $T = 30$  min.**

Feed rate  $S_a = 0,4 \text{ mm/r}$  ;  $S_b = 1,3 \cdot 1 \cdot 0,4 = 0,52 \text{ mm/r}$  ;  $S_c = 0,87 \cdot 0,45 \approx 0,4 \text{ mm/r.}$ , accepted feed rate  **$S = 0,43 \text{ mm/r}$**

**The cutting speed  $V$** , mpm (meter per minute), is calculated by the formula:

$$V = \frac{C_V}{(T^m \cdot t^x \cdot s^y)} \cdot K_V,$$

The value of factor  $C_V$  and parameters of a degree are given in tab. 17. For considered draft turning of an outside surface we accept that the depth of cut will be equal to the greatest depth of cut:  $t = t_{\max} = 2.075$  mm. Factors and parameters of degrees are defined from tab. 17 [1]:

$$C_V=350; x=0.15; y=0.35; m=0.20.$$

$K_V$  - correction factor which takes into account geometry of cutting tool.

$$K_V = K_{Mv} \times K_{lv} \times K_{sv} \times K_{\varphi v} \times K_{\varphi 1v} \times K_{rv} \times K_{Ov}, \quad (7.2)$$

Where  $K_{Mv} = 1$

$$K_{tv} = 1$$

$$K_{sv} = 0.8$$

$$K_{\phi v} = 0.7$$

$$K_{\phi lv} = 1$$

$$K_{rv} = 1$$

$$K_{Ov} = 1$$

$$K_V = 1 \times 1 \times 0.8 \times 0.7 \times 1 \times 1 \times 1 = 0.56.$$

$$V = \frac{C_V}{(T^m \cdot t^x \cdot s^y)} \cdot K_V = \frac{350}{(30^{0.20} \cdot 2.075^{0.15} \cdot 0.43^{0.35})} \cdot 0.56 = 119.55 \text{ mpm.}$$

### Cutting forces:

It is accepted to split the force of cutting P on making (component) forces which are directed on axes of coordinates of the machine tool (Pz, Py, Px).

For outside longitudinal turning:

$$P_{z,y,x} = C_P \times t^x \times s^y \times V^n \times K_P, \text{ [N]},$$

$$K_P = K_{Mp} \times K_{\phi p} \times K_{\gamma p} \times K_{\lambda p} \times K_{Rp}, \quad (7.4)$$

Table 7.1. Calculation of cutting component forces at rough turning  $\text{Ø}33.58h12$

Compo- nents	$C_P$	$x$	$y$	$n$	$K_{Mp}$	$K_{\phi p}$	$K_{\gamma p}$	$K_{\lambda p}$	$K_{Rp}$	$K_P$	$P_{z,y,x}$ N
$P_z$	300	1	0.75	- 0.15	1	0.89	1	1	1	0.89	1435.4
$P_y$	243	0.9	0.6	-0.3	1	0.50	1	1	1	0.5	336.3
$P_x$	339	1	0.5	-0.4	1	1.17	1	1	1	1.17	796.3

$$P_z = 10 \times 300 \times 2.075^1 \times 0.43^{0.75} \times 119.55^{-0.15} \times 0.89 = 1435.4 \text{ N};$$

$$P_y = 10 \times 243 \times 2.075^{0.9} \times 0.43^{0.6} \times 119.55^{-0.3} \times 0.5 = 336.3 \text{ N};$$

$$P_x = 10 \times 339 \times 2.075^1 \times 0.43^{0.5} \times 119.55^{-0.4} \times 1.17 = 796.3 \text{ N};$$

### Cutting Power:

$$N = \frac{P_z \cdot V}{1020 \cdot 60}, [\text{kW}] \quad (7.5)$$

Where  $P_z$  - tangential component of cutting force (conterminous on a direction with a vector of cutting speed), N;  $V$  - cutting speed, mpm.

In our case at rough turning of an outside surface **Ø33.58h12**:

$$N = \frac{1435.4 \cdot 119.55}{1020 \cdot 60} = 2.80 \text{ kW.}$$

We calculate number of revolutions of a spindle per 1 minute  $n_{cal}$ :

$$n_{cal} = \frac{1000 \cdot V}{\pi \cdot d_{max}} = \frac{1000 \cdot 119.55}{\pi \cdot 37.48} = 1015 \text{ rpm}$$

The real speed of cutting  $N_r$ :

$$V_o = \frac{\pi \cdot 37.48 \cdot 1000}{1000} = 117.7 \text{ mpm.}$$

**Specified (real) power of cutting  $N_r$ :**

$$N_r = \frac{1435.4 \cdot 117.7}{1020 \cdot 60} = 2.76 \text{ kW}$$

### 6.7. Calculation of cutting modes for semi-finish turning **Ø32.75h9**

**Chosen cutting tool: T15k6;**

Cutting tool parameters:  $\varphi = 90^\circ$ ;  $\varphi_1 = 10^\circ$ ;  $r = 0,8 \text{ mm}$ ;  $\gamma = 10^\circ$

While:  $\varphi$  – main cutting angle;  $\varphi_1$  – auxiliary cutting angle;  $r$  – nose radius;  $\gamma$  – rake angle. Shank size 16×25

### Cutting Speed:

The size of the processed surface  $d_i = \mathbf{32.75h9}$ . The size of a processable surface -  $d_{i-1} = \mathbf{Ø33.58h12}$  (diameter of a rod).

We calculate the greatest depth of cutting  $t_{max}$ , if we remove all stock on rough (draft) processing for one pass (after 1 stroke):

$$t_{max} = (d_{(i-1)max} - d_{imin})/2 = = (33.58) - (32.75-0,062)/2 = \mathbf{0.446 \text{ mm.}}$$

Cutting tool life for semi finish **T = 15 min**

Feed rate  $S_a = 0,4 \text{ mm/r}$  ;  $S_b = 1,3 \cdot 1 \cdot 0,4 = 0,52 \text{ mm/r}$  ;  $S_c = 0,20 \cdot 0,45 = 0,09 \text{ mm/r}$ , accepted feed rate  $S = 0,07 \text{ mm/r}$

**The cutting speed V**, mpm (meter per minute), is calculated by the formula:

$$V = \frac{C_V}{(T^m \cdot t^x \cdot s^y)} \cdot K_V,$$

The value of factor  $C_V$  and parameters of a degree are given in tab. 17. For considered draft turning of an outside surface we accept that the depth of cut will be equal to the greatest depth of cut:  $t = t_{max} = 0,321 \text{ mm}$ . Factors and parameters of degrees are defined from tab. 17 [1]:

$$C_V=420; x=0.15; y=0.20; m=0.20.$$

$K_V$  - correction factor which takes into account geometry of cutting tool.

$$K_V = K_{Mv} \times K_{tv} \times K_{sv} \times K_{\phi v} \times K_{\phi lv} \times K_{rv} \times K_{Ov}, \quad (7.2)$$

Where  $K_{Mv} = 1$

$$K_{tv} = 1$$

$$K_{sv} = 1$$

$$K_{\phi v} = 0.7$$

$$K_{\phi lv} = 1$$

$$K_{rv} = 0,94$$

$$K_{Ov} = 1$$

$$K_V = 1 \times 1 \times 1 \times 0,7 \times 1 \times 0,94 \times 1 = 0,658.$$

$$V = \frac{C_V}{(T^m \cdot t^x \cdot s^y)} \cdot K_V = \frac{420}{(15^{0.20} \cdot 0.446^{0.15} \cdot 0.07^{0.20})} \cdot 0.658 = 308.9 \text{ mpm.}$$

### Cutting Forces:

It is accepted to split the force of cutting P on making (component) forces which are directed on axes of coordinates of the machine tool (Pz, Py, Px).

For outside longitudinal turning:

$$P_{z, y, x} = C_P \times t^x \times s^y \times V^n \times K_P, \text{ [N]},$$

$$K_P = K_{Mp} \times K_{\phi p} \times K_{\gamma p} \times K_{\lambda p} \times K_{Rp}, \quad (7.4)$$

Table 7.1. Calculation of cutting component forces at rough turning  $\text{Ø}32.75h9$

Compo- nents	$C_P$	$x$	$y$	$n$	$K_{Mp}$	$K_{\phi p}$	$K_{\gamma p}$	$K_{\lambda p}$	$K_{Rp}$	$K_P$	$P_{z,y,x}$ N
$P_z$	300	1	0.75	- 0.15	1	0.89	1	1	1	0.89	68.5
$P_y$	243	0.9	0.6	-0.3	1	0.50	1	1	1	0.5	21.3
$P_x$	339	1	0.5	-0.4	1	1.17	1	1	1	1,17	47.2

$$P_z = 10 \times 300 \times 0,446^1 \times 0,07^{0.75} \times 308.9^{-0.15} \times 0,89 = 68.5 \text{ N};$$

$$P_y = 10 \times 243 \times 0,446^{0.9} \times 0.07^{0.6} \times 308.9^{-0.3} \times 0.5 = 21.3 \text{ N};$$

$$P_x = 10 \times 339 \times 0,446^1 \times 0.07^{0.5} \times 308.9^{-0.4} \times 1.17 = 47.2 \text{ N};$$

### Cutting Power:

$$N = \frac{P_z \cdot V}{1020 \cdot 60}, [\text{kW}] \quad (7.5)$$

Where  $P_z$  - tangential component of cutting force (conterminous on a direction with a vector of cutting speed), N;  $V$  - cutting speed, mpm.

In our case at semi-finish turning of an outside surface  $\text{Ø}32.82h9$ :

$$N = \frac{68.5 \cdot 308.9}{1020 \cdot 60} = 0.34 \text{ kW}.$$

We calculate number of revolutions of a spindle per 1 minute  $n_{cal}$ :

$$n_{cal} = \frac{1000 \cdot V}{\pi \cdot d_{max}} = \frac{1000 \cdot 308.9}{\pi \cdot 33.58} = 2928 \text{ rpm}$$

The real speed of cutting Nr:

$$V_o = \frac{\pi \cdot 33.58 \cdot 3000}{1000} = 316.4 \text{ mpm}.$$

**Specified (real) power of cutting  $N_r$ :**

$$N_r = \frac{68.5 \cdot 316.4}{1020 \cdot 60} = 0.35 \text{ kW}$$

### 6.8. Calculation of cutting modes for rough turning Ø42h14

**Chosen cutting tool: T15k6;**

**Cutting tool parameters:**  $\varphi = 90^\circ$ ;  $\varphi_1 = 10^\circ$ ;  $r = 2,5\text{mm}$ ;  $\gamma = 10^\circ$

While:  $\varphi$  – main cutting angle;  $\varphi_1$  – auxiliary cutting angle;  $r$  – nose radius;  $\gamma$  – rake angle. Shank size 16×25

**Cutting speed:**

The size of the processed surface  $d_i = \text{Ø}40\text{h}14$ . The size of a processable surface -  $d_{i-1} = \text{Ø}45_{-0,4}^{+0,8}$  (diameter of a rod). **Previously** we calculate the greatest depth of cutting  $t_{\max}$ , if we remove all stock on rough (draft) processing for one pass (after 1 stroke):

$$t_{\max} = (d_{(i-1)\max} - d_{i\min})/2 = (45+0,8) - (42-0,62)/2 = 2.21 \text{ mm}$$

We accept the greatest depth of cutting  $t_{\max} = 2.21 \text{ mm}$ .

Cutting tool life for rough turning **T = 30 min.**

Feed rate  $S_a = 0,4 \text{ mm/r}$  ;  $S_b = 1,3 \cdot 1 \cdot 0,4 = 0,52 \text{ mm/r}$  ;  $S_c = 0,87 \cdot 0,45 \approx 0,4 \text{ mm/r}$ ., accepted feed rate **S = 0,43 mm/r**

**The cutting speed V**, mpm (meter per minute), is calculated by the formula:

$$V = \frac{C_V}{(T^m \cdot t^x \cdot s^y)} \cdot K_V,$$

The value of factor  $C_V$  and parameters of a degree are given in tab. 17. For considered draft turning of an outside surface we accept that the depth of cut will be equal to the greatest depth of cut:  $t = t_{\max} = 2.21 \text{ mm}$ . Factors and parameters of degrees are defined from tab. 17 [1]:

$$C_V=350; x=0.15; y=0.35; m=0.20.$$

$K_V$  - correction factor which takes into account geometry of cutting tool.

$$K_V = K_{Mv} \times K_{tv} \times K_{sv} \times K_{\varphi v} \times K_{\varphi 1v} \times K_{rv} \times K_{Ov}, \quad (7.2)$$

Where  $K_{Mv} = 1$

$$K_{tv} = 1$$

$$K_{sv} = 0.8$$

$$K_{\varphi v} = 0.7$$

$$K_{\varphi 1v} = 1$$

$$K_{rv} = 1$$

$$K_{Ov} = 1$$

$$K_V = 1 \times 1 \times 0.8 \times 0.7 \times 1 \times 1 \times 1 = 0.56.$$

$$V = \frac{C_V}{(T^m \cdot t^x \cdot s^y)} \cdot K_V = \frac{350}{(30^{0.20} \cdot 2.21^{0.15} \cdot 0.43^{0.35})} \cdot 0.56 = 118.4 \text{ mpm.}$$

### Cutting forces:

It is accepted to split the force of cutting P on making (component) forces which are directed on axes of coordinates of the machine tool (Pz, Py, Px).

For outside longitudinal turning:

$$P_{z,y,x} = C_P \times t^x \times s^y \times V^n \times K_P, \text{ [N]},$$

$$K_P = K_{Mp} \times K_{\phi p} \times K_{\gamma p} \times K_{\lambda p} \times K_{Rp}, \quad (7.4)$$

Table 7.1. Calculation of cutting component forces at rough turning  $\text{Ø}33.58h12$

Compo- nents	$C_P$	$x$	$y$	$n$	$K_{Mp}$	$K_{\phi p}$	$K_{\gamma p}$	$K_{\lambda p}$	$K_{Rp}$	$K_P$	$P_{z,y,x}$ , N
$P_z$	300	1	0.75	- 0.15	1	0.89	1	1	1	0.89	1531
$P_y$	243	0.9	0.6	-0.3	1	0.50	1	1	1	0.5	356.9
$P_x$	339	1	0.5	-0.4	1	1.17	1	1	1	1,17	851.4

$$P_z = 10 \times 300 \times 2.21^1 \times 0.43^{0.75} \times 118.4^{-0.15} \times 0.89 = 1531 \text{ N};$$

$$P_y = 10 \times 243 \times 2.21^{0.9} \times 0.43^{0.6} \times 118.4^{-0.3} \times 0.5 = 356.9 \text{ N};$$

$$P_x = 10 \times 339 \times 2.21^1 \times 0.43^{0.5} \times 118.4^{-0.4} \times 1.17 = 851.4 \text{ N};$$

### Cutting Power:

$$N = \frac{P_z \cdot V}{1020 \cdot 60}, \text{ [kW]} \quad (7.5)$$

Where  $P_z$  - tangential component of cutting force (conterminous on a direction with a vector of cutting speed), N;  $V$  - cutting speed, mpm.

In our case at rough turning of an outside surface  $\text{Ø}33.58h12$ :

$$N = \frac{1531 \cdot 118.4}{1020 \cdot 60} = 2.96 \text{ kW.}$$

We calculate number of revolutions of a spindle per 1 minute  $n_{cal}$ :

$$n_{cal} = \frac{1000 \cdot V}{\pi \cdot d_{max}} = \frac{1000 \cdot 118.4}{\pi \cdot 45.8} = 822.8 \text{ rpm}$$

The real speed of cutting  $N_r$ :

$$V_o = \frac{\pi \cdot 45.8 \cdot 1000}{1000} = 143.8 \text{ mpm.}$$

**Specified (real) power of cutting  $N_r$ :**

$$N_r = \frac{1531 \cdot 143.8}{1020 \cdot 60} = 3.6 \text{ kW}$$

**Machining time:**

$$Mt = \frac{l}{s \cdot n} = \frac{24.18}{0.43 \cdot 2300} = 0.024$$

## 6.9. Calculation of cutting modes and forces at milling key slot 10H9

We choose the cutting tool by recommendations [2, page 450]: **two-flute** single-end milling cutter  $\varnothing 10$  mm from solid cutter made of one piece of high-speed steel P6M5. Two-flute end mills have only two teeth. The end teeth are designed so that they can cut to the center of the mill. Therefore, two-flute end mills may be fed into the work like a drill; they then may be fed lengthwise to form a slot.

Depth of cut at milling of key slot  $t = 5 + 0.69 \text{ mm} = 5.69$  mm. Maximal width is used about  $b \approx 0.5 \times D = 0.5 \times 10 = 5$  mm, the depth of key slot on external surface of manufactured cartridge  $t_1 = 5$  mm, that is why width of milling  $b = 5$  mm.

Maximal feed rate for one teeth  $S_z$  is chosen in accordance with rigidness of mill (diameter of mill  $\varnothing 10$  mm), cutting tool material (HSS P6M5), processable material (steel 40X), surface roughness of slot sides ( $R_a < 6.3 \text{ } \mu\text{m}$ ) and recommendations which are given in tab. 38 [1, page 286] for two-flute mills (quantity of teeth  $z = 2$ ): axial feed rate  $S_{z \text{ ax}} = 0.008$  mm per tooth, lengthwise feed rate  $S_{z \text{ lw}} = 0.024$  mm per tooth.

The cutting **speed** at milling is calculated by the formula:

$$V = \frac{C_V \cdot D^q}{(T^m \cdot t^x \cdot s_z^y \cdot B^u \cdot z^p)} \cdot K_V, \quad (7.17)$$

Where: T - cutting tool life (at key slot milling T=80 minutes, tab. 40 [1, page 290]).

Values of factor  $C_V$  and parameters of a degree for a two-flute mills from HSS and milling with cooling in processable constructional steel (steel 40X) are given in tab. 39 [1, page 286]:

$$C_V=12; \quad q = 0.3; \quad x=0.3; \quad y=0.25; \quad u=0; \quad p=0; \quad m=0.26.$$

$K_V$  - correction factor:

$$K_V = K_{M_V} \times K_{H_V} \times K_{I_V}, \quad (7.18)$$

Where  $K_{M_V} = 75/\sigma_\delta$  - factor which is taking into account influence of quality of a processable material (durability) on cutting speed. For steel 40X strength of a stretching  $\sigma_\delta=75 \text{ kg / mm}^2$ , therefore  $K_{M_V} = 75/\sigma_\delta = 75/75 = 1$ ;

$K_{H_V}$  - factor which taking into account material of a cutting part. For a cutting tool from HSS P6M5  $K_{H_V}=1$  [1, page 263, tab.6];

$K_{I_V}=1$  - factor which is taking into account a blank surface condition [1, page 263, tab.5].

$$K_V = 1 \times 1 \times 1 = 1.$$

$$V = \frac{C_V \cdot D^q}{(T^m \cdot t^x \cdot s_z^y \cdot B^u \cdot z^p)} \cdot K_V = \frac{12 \cdot 10^{0.3}}{(80^{0.26} \cdot 5.69^{0.3} \cdot 0.024^{0.25} \cdot 5^0 \cdot 2^0)} \cdot 1 = 11.5$$

mpm.

We calculate number of revolutions of a spindle  $n_{cal}$ :

$$n_{cal} = \frac{1000 \cdot V}{\pi \cdot d_{max}} = \frac{1000 \cdot 11.5}{3.14 \cdot 10} = 366 \text{ rpm},$$

Where  $d_{max}$  – the greatest diameter of working cutting edge relatively of axis of the rotating tool, mm.

In the technical passport of the machine tool we find the nearest smaller number of revolutions of a spindle (smaller - since even at insignificant increasing of cutting speed can result an essential reduction of cutting tool life  $T$ ):  $n_{pas} = 400 \text{ rpm}$ . We calculate the **real** (specified or corrected) **cutting speed** at the accepted number of revolutions of a spindle by the formula (7.6):

$$V_r = \frac{\pi \cdot d \cdot n_{pas}}{1000} = \frac{3.14 \cdot 10 \cdot 400}{1000} = 12.5 \text{ mpm}.$$

Calculation of tangential **component of cutting force**  $P_z$  [N], at milling is done by the formula

$$P_z = \frac{10 \cdot C_p \cdot t^x \cdot s_z^y \cdot B^u \cdot z}{D^q \cdot n^w} \cdot K_{mp}. \quad (7.19)$$

Values of factor  $C_V$  and parameters of a degree for end mills from HSS and milling in processable constructional steel (steel 40X) are given in tab. 41 [1, page 291]:

$$C_p=68.2; q = 0.86; x=0.86; y=0.72; u=1; w=0.$$

$K_{mp}$  - correction factor:

$$K_{mp} = K_{Mp} \times K_{Ip} \times K_{Iip}, \quad (7.20)$$

Where  $K_{Mp} = 75/\sigma_s$  - factor which is taking into account influence of quality of a processable material (durability) on cutting speed. For steel 40X strength of a stretching  $\sigma_s=75 \text{ kg / mm}^2$ , therefore  $K_{Mp} = 75/\sigma_s = 75/75 = 1$ ;

$K_{Ip}$  - factor which taking into account material of a cutting part. For a cutting tool from HSS P6M5  $K_{Ip} = 1$  [1, page 263, tab.6];

$K_{Iip} = 1$  - factor which is taking into account a blank surface condition [1, page 263, tab.5].

$$K_V = 1 \times 1 \times 1 = 1.$$

$$P_z = \frac{10 \cdot C_p \cdot t^x \cdot s_z^y \cdot B^u \cdot z}{D^q \cdot n^w} \cdot K_{mp} = \frac{10 \cdot 68.2 \cdot 5.69^{0.86} \cdot 0.024^{0.72} \cdot 5^1 \cdot 2}{10^{0.86} \cdot 400^0} \cdot 1 = 286 \text{ [N]}.$$

Other components of cutting force are calculated by the ratios [1, page 292, table 42]:

$$P_h: P_z = 0.3 - 0.4; P_h = P_z \cdot 0.4 = 286 \cdot 0.4 = 114.4 \text{ [N]};$$

$$P_v: P_z = 0.85 - 0.95; P_v = P_z \cdot 0.95 = 286 \cdot 0.95 = 271.7 \text{ [N]};$$

$$P_{ic}: P_z = 0.3 - 0.4; P_y = P_z \cdot 0.4 = 286 \cdot 0.4 = 114.4 \text{ [N]};$$

$$P_x: P_z = 0.5 - 0.55; P_x = P_z \cdot 0.55 = 286 \cdot 0.55 = 157.3 \text{ [N]};$$

The **cutting power** at milling key slot 10H9 is calculated by the formula (7.5):

$$N = \frac{P_z \cdot V}{1020 \cdot 60} = \frac{286 \cdot 12.5}{1020 \cdot 60} = 0.058 \text{ kW}.$$

Where  $P_z$  - tangential component of cutting force (conterminous on a direction with a vector of cutting speed), N;  $V$  - cutting speed, mpm.

## 6.10. Calculation of cutting modes and power at round grinding Ø25,8h9

We choose the cutting tool by recommendations [1, pages 242, 245, 246, 249, 250, 252 - 254]:

1. The **type of abrasive** is A14 (normal aluminum oxide) [1, pages 242] or A (Alundum) in accordance with American terminology. Aluminum oxide grains or crystals, although not the hardest artificial abrasive, are tough and are best for grinding materials of high-tensile strength. They are used to grind carbon steels, alloy steels, soft or hard steels, cast-alloy cutting tools, wrought iron, and tough bronze.
2. The **grain size** - 25 (fine grinding of parts with  $Ra < 1.25 \mu\text{m}$  and with grade of tolerance 7...8) [1, page 247]. Grain refers to the size of the abrasive particles used in the manufacture of the grinding wheel. The grain size is determined by the **mesh number** of the finest screen through which the grain will pass. For example, a 36-grain wheel is one made of particles of abrasive which just pass through a 36-mesh screen, but which will be retained on a 46-mesh screen, the next finer screen. (A 36-mesh screen has 36 openings each lineal 25.4 mm, or 200 openings per square centimeter. Grain numbers are sometimes called **grit numbers**.)
3. The **bond** is K2 (S2 in accordance with American terminology) (silicate-bonded wheels which are used for grinding steel parts) [1, page 247]. The **bond** is the material which holds the abrasive grains together to form the grinding wheel. As the grains get dull, pressure on the wheel causes the bond to break down and release the dull grains, thus exposing new sharp grains. The bond holds the individual grain in much the same manner as a toolholder holds a tool bit. There are five basic types of bonds used in grinding wheels: **vitrified, silicate, rubber, shellac, and resinoid**. Additional modifications of these five materials are also produced by some manufacturers. Approximately 75% of all wheels are made with **vitrified** or a modified vitrified bond. Vitrified-bond wheels are strong, porous, and are not affected by rapid changes in temperature, oils, acid, or water. These wheels are uniform in structure, free from hard spots, and hold their form well. The bond is formed when special clays are mixed with abrasive grains and heated to high temperatures. The mixture forms a molten glass which cements the grains together. Wheels bonded with **silicate** (silicate of soda) are known as silicate- or semi-vitrified-bond wheels. Silicate-bonded wheels release the grains more readily than vitrified bond. Hence, the wheel is softer and it breaks down more readily, thereby exposing new sharp grains. Silicate-bonded wheels are used for grinding steel parts, edge tools, drills, reamers, milling cutters, and similar tools.
4. The **hardness of grinding wheel** is CM2 (which is rated between soft and medium) [4, page 59] or H grade in accordance with American terminology. Wheels from which the grit or abrasive is readily torn are termed **soft grade**. Conversely, wheels that do not readily release the grain are called

**hard grade.** **Hard-grade** wheels generally are used for grinding soft metals such as mild steel. **Soft-grade** wheels generally are used for grinding hard metals such as high-carbon steel. It should be remembered that the term hard as used with respect to grinding wheels has no relationship to the hardness of the abrasive, but rather to the ease or difficulty with which the worn particles of the abrasive are torn from the face of the wheel. With a given bond material, it is the amount of bond which determines the hardness or softness of the wheel - the more bond material, the harder the wheel. The grade of grinding wheels is designated by letters of the alphabet, A being the softest and Z the hardest, [4, table 22-2].

5. The **structure** of a grinding wheel is 8 (middle density). The **structure** of a grinding wheel refers to the spacing between the grains, or the density of the wheel. Grains which are very closely spaced are denser or close, while grains which are wider apart are less dense or open. The structure of a wheel is rated with numbers from 1 (dense) to 15 (open). The rate of metal removal usually is greater for wheels with an open structure. However, those with dense structure usually produce a finer finish.

The marking on the grinding wheel is III 250-25-50 25A 25 CM1 8 K2/IIIC 40 15 in accordance with Russian terminology. This marking indicates that the type of grinding wheel is straight profile (III), external diameter is 250 mm, height (width) is 25 mm, diameter of hole is 50 mm; type of abrasive is type 14A (normal aluminum oxide); with a 25 medium grain size; with CM1 grade (which is rated between soft and medium); structure 8 (middle density); bond type K2 (which is silicate-bonded); and IIIC 40 15 represents the manufacturer's mark for the specific type of silicate bond (the porosity used material is polystyrene IIIC with 40 grain size and space containing in abrasive weight is 15 present. A grinding wheel of this type will do a good job in surface-grinding hardened carbon steel.

The standard system for marking wheels adopted by the American Standards Association includes six parts in sequence, as listed across the top of Table 22-2 [4]. Note that the prefix to item one in the sequence is optional for each manufacturer. For example, where several types of a given abrasive are available, such as several variations of aluminum oxide, the prefix number indicates the exact type of aluminum oxide. Also note that items four and six in the sequence are optional with the manufacturer.

Grinding wheel markings adopted by the American Standards Association is T1 250-25-50 25A -H8SBE [4, page 59]. This marking indicates that the type-number (shape) of grinding well is 1 (with straight profile) [1, page 56], the diameter of grinding wheel is 250 mm, the diameter of grinding well hole is 50 mm (the diameter of the spindle hole), the height (the width) of grinding well is 25 mm, the abrasive is type 25 Alundum with a 25 medium grain size; with H grade (which is rated between soft and medium); structure 8 (middle density); bond type S (which is silicate); and BE represents the manufacturer's mark for the specific type of silicate bond. A grinding wheel of this type will do a good job in surface-grinding hardened

carbon steel.

Cutting modes for feed rate for double pass are chosen by recommendations [1, pages 301]:

1. Cutting speed  $V = 30 \dots 35$  mps (tangential speed of grinding wheel)  
 $n_{gw} = 60000 \times V / (\pi \times d_{gw}) = 60000 \times 30 / (\pi \times 250) = 2293 \approx 2500$  rpm.
2. Tangential speed of a part  $V_p = 20 \dots 30$  mpm;  $n_p = 1000 \times V / (\pi \times d_p) = 1000 \times 20 / (\pi \times 25.8) = 246.8 \approx 250$  rpm; corrected speed of part  $V_{p\ cor} = \pi \times d_p \times n_p / 1000 = 3.14 \times 25.8 \times 250 / 1000 = 20.2$  mpm.
3. Depth of cut (of grinding)  $t = 0.015 \dots 0.05$  mm. We accept  $t = 0.03$  mm.
4. Lengthwise feed rate  $S = (0.3 \dots 0.7) \times B = 0.5 \times 25 = 12.5$  mmpr, where B is the length of working part of the wheel.
5. Quantity of passes is calculated by the formula:

$$i = 2 \cdot z_{max\ i} / 2 \cdot t = z_{max\ i} / t, \quad (7.15)$$

Where  $2 \cdot z_{max}$  is maximal stock in considered technological transition. Maximal stock is calculated:  $2 \cdot z_{max\ i} = d_{(i-1)\ max} - d_{i\ min} = 25.8 - 25.015 = 0.785$  mm.  
 $d_{i-1} = \text{Ø}25.8h9_{(-0.052)}$ ,  $d_i = \text{Ø}25n6_{(+0.028 / +0.015)}$ .

$$i = 2 \cdot z_{max} / 2 \cdot t = 0.785 / 2 \cdot 0.05 = 7.85 \approx 8$$

We accept  $i = 8$ , because we are to add one pass for reducing depth of cut in last pass and reducing errors of grinding which are appeared due to elastic recovering of part and machine tool mechanism (errors of size, out of roundness and cylindrical, roughness of surface). We are take into account time for returning grinding well in right side for cross feed of well (idle passes). That is why whole quantity of passes is equal 10 (5 of working and 5 of idle passes).

The **cutting power** for feed rate for double pass at round grinding Ø25.8h9 is calculated by the formula:

$$N = C_N \times V_p^r \times t^x \times s^y \times d^q, \quad (7.16)$$

Where  $C_N = 2.65$ ;  $r = 0.5$ ;  $x = 0.5$ ;  $y = 0.55$ ;  $q = 0$  [4, page 301].

$$N = C_N \times V_p^r \times t^x \times s^y \times d^q = 2.65 \times 20.2^{0.5} \times 0.03^{0.5} \times 12.5^{0.55} \times 25.8^0 = 8 \text{ kW.}$$

Grinding machine is chosen in accordance with the type of work (grinding of external cylindrical surface), the diameter of processable part (Ø25.8 mm) and the length (L=23 mm), the required power of grinding driver (N=7 kW). We choose plain grinding machine 3M153 [1, page 29] with maximal diameter of processable part Ø500 mm but recommended diameter of external grinding is Ø10...45 mm,

maximal length of grinding is 340 mm, maximal longitudinal moving of grinding table with headstock is 400 mm, frequency of blank spindle rotation is stepless (with variable-speed mechanism) from 100 to 1000 rpm, frequency of grinding spindle rotation is 2350 and 1670 rpm for external grinding, maximal diameter of grinding wheel is 500 mm, maximal height of grinding well is 40 mm, maximal cross moving of grinding tailstock is 80 mm with resolution 0.0005 mm, power of grinding driver is 7.5 kW, diameter of grinding wheel hole is 50 mm.

## 6.10. Calculation of cutting modes and power at round grinding Ø32g6

Cutting modes for feed rate for double pass are chosen by recommendations [1, pages 301]:

1. Cutting speed  $V = 30 \dots 35$  mps (tangential speed of grinding wheel)  
 $n_{gw} = 60000 \times V / (\pi \times d_{gw}) = 60000 \times 30 / (\pi \times 250) = 2293 \approx 2500$  rpm.
2. Tangential speed of a part  $V_p = 20 \dots 30$  mpm;  $n_p = 1000 \times V / (\pi \times d_p) = 1000 \times 20 / (\pi \times 32.75) = 194 \approx 200$  rpm; corrected speed of part  $V_{p\ cor} = \pi \times d_p \times n_p / 1000 = 3.14 \times 32.75 \times 250 / 1000 = 25.8$  mpm.
3. Depth of cut (of grinding)  $t = 0.015 \dots 0.05$  mm. We accept  $t = 0.03$  mm.
4. Lengthwise feed rate  $S = (0.3 \dots 0.7) \times B = 0.5 \times 25 = 12.5$  mmpr, where B is the length of working part of the wheel.
5. Quantity of passes is calculated by the formula:

$$i = 2 \cdot z_{max\ i} / 2 \cdot t = z_{max\ i} / t, \quad (7.15)$$

Where  $2 \cdot z_{max\ i}$  is maximal stock in considered technological transition. Maximal stock is calculated:  $2 \cdot z_{max\ i} = d_{(i-1)\ max} - d_{i\ min} = 32.75 - 31.975 = 0.775$  mm.  
 $d_{i-1} = \text{Ø}32.75h9_{(-0.062)}$ ,  $d_i = \text{Ø}32g6_{(+0.025)}$ .

$$i = 2 \cdot z_{max} / 2 \cdot t = 0.775 / 2 \cdot 0.05 = 7.75 \approx 8$$

The **cutting power** for feed rate for double pass at round grinding Ø32g6 is calculated by the formula:

$$N = C_N \times V_p^r \times t^x \times s^y \times d^q, \quad (7.16)$$

Where  $C_N = 2.65$ ;  $r = 0.5$ ;  $x = 0.5$ ;  $y = 0.55$ ;  $q = 0$  [4, page 301].

$$N = C_N \times V_p^r \times t^x \times s^y \times d^q = 2.65 \times 25.8^{0.5} \times 0.03^{0.5} \times 12.5^{0.55} \times 32.75^0 = 9 \text{ kW.}$$

## 6.11. Calculation of cutting modes and power at round grinding Ø32s7

Cutting modes for feed rate for double pass are chosen by recommendations [1, pages 301]:

1. Cutting speed  $V = 30 \dots 35$  mps (tangential speed of grinding wheel)  
 $n_{\text{gw}} = 60000 \times V / (\pi \times d_{\text{gw}}) = 60000 \times 30 / (\pi \times 250) = 2293 \approx 2500$  rpm.
2. Tangential speed of a part  $V_p = 20 \dots 30$  mpm;  $n_p = 1000 \times V / (\pi \times d_p) = 1000 \times 20 / (\pi \times 32.75) = 194 \approx 200$  rpm; corrected speed of part  $V_{p \text{ cor}} = \pi \times d_p \times n_p / 1000 = 3.14 \times 32.82 \times 250 / 1000 = 25.7$  mpm.
3. Depth of cut (of grinding)  $t = 0.015 \dots 0.05$  mm. We accept  $t = 0.03$  mm.
4. Lengthwise feed rate  $S = (0.3 \dots 0.7) \times B = 0.5 \times 25 = 12.5$  mmpr, where  $B$  is the length of working part of the wheel.
5. Quantity of passes is calculated by the formula:

$$i = 2 \cdot z_{\text{max } i} / 2 \cdot t = z_{\text{max } i} / t, \quad (7.15)$$

Where  $2 \cdot z_{\text{max}}$  is maximal stock in considered technological transition. Maximal stock is calculated:  $2 \cdot z_{\text{max } i} = d_{(i-1) \text{ max}} - d_{i \text{ min}} = 32.82 - 32.043 = 0.777$  mm.  
 $d_{i-1} = \text{Ø}32.82\text{h}9_{(-0.062)}$ ,  $d_i = \text{Ø}32\text{s}7_{(+0.068 / +0.048)}$ .

$$i = 2 \cdot z_{\text{max}} / 2 \cdot t = 0.777 / 2 \cdot 0.05 = 7.77 \approx 8$$

The **cutting power** for feed rate for double pass at round grinding Ø32s7 is calculated by the formula:

$$N = C_N \times V_p^r \times t^x \times s^y \times d^q, \quad (7.16)$$

Where  $C_N = 2.65$ ;  $r = 0.5$ ;  $x = 0.5$ ;  $y = 0.55$ ;  $q = 0$  [4, page 301].

$$N = C_N \times V_p^r \times t^x \times s^y \times d^q = 2.65 \times 25.7^{0.5} \times 0.03^{0.5} \times 12.5^{0.55} \times 32.82^0 = 9 \text{ kW.}$$

## 6.12 Calculation of cutting modes and forces at milling face Ø16h14

We choose the cutting tool by recommendations [2, page 450]: **Face mill** cutter Ø20 mm from solid cutter made of cemented carbide T15K6. At face milling for achievement of productive cutting modes the diameter of mill  $D$  should be more width of milling  $B$ , i.e.  $D = (1.25 \dots 1.5) \times B = 1.25 \times 16 = \mathbf{20 \text{ mm}}$ , and at machining of blanks their asymmetrical arrangement concerning a mill is obligatory: for carbon steel and alloyed steel blanks – their shift (displacement) in a direction of **incision** (start of cutting) of a mill tooth, than a small thickness of a cut off layer is provided in the cutting beginning; for heat-resistance and corrosion-resistance steel blanks – shift of blank towards an exit of a mill tooth from cutting, than minimum possible

thickness of a cut off layer is provided at exiting of tooth from cutting. Non-observance of the specified rules leads to considerable decreasing of cutting tool life

Depth of cut of milling the face is **t=1.75mm**.

**Feed rate:** according to the power of the machine tool 5-10 kw and inserts material T15K6 **S=0.09-0.18 mm/tooth**,

According to mill diameter D= Ø20mm and depth of cut t=1.75mm

**S=0.06-0.10 mm/tooth**

**Accepted feed rate S=0.10mm/tooth**

**Cutting tool life-** with machining of steel for face mill **T=120 min**

The cutting **speed** at milling is calculated by the formula:

$$V = \frac{C_V \cdot D^q}{(T^m \cdot t^x \cdot s_z^y \cdot B^u \cdot z^p)} \cdot K_V, \quad (7.17)$$

Where T cutting tool life. In Face milling T=120 minutes.

Values of factor  $C_V$  and parameters of a degree for a two-flute mills from HSS and milling with cooling in processable constructional steel (steel 40X) are given in tab. 39 [1, page 286]:

$$C_V=332; q = 0.2; x=0.1; y=0.4; u=0.2; p=0; m=0.2.$$

$K_V$  - correction factor:

$$K_V = K_{M_V} \times K_{I_V} \times K_{II_V}, \quad (7.18)$$

Where  $K_{M_V} = 75/\sigma_s$  - factor which is taking into account influence of quality of a processable material (durability) on cutting speed. For steel 40X strength of a stretching  $\sigma_s=75 \text{ kg / mm}^2$ , therefore  $K_{M_V} = 75/\sigma_s = 75/75 = 1$ ;

$K_{I_V}$  - factor which taking into account material of a cutting part. For a cutting tool from HSS P6M5  $K_{I_V} = 1$  [1, page 263, tab.6];

$K_{II_V} = 1$  - factor which is taking into account a blank surface condition [1, page 263, tab.5].

$$K_V = 1 \times 1 \times 1 = 1.$$

$$V = \frac{C_V \cdot D^q}{(T^m \cdot t^x \cdot s_z^y \cdot B^u \cdot z^p)} \cdot K_V = \frac{332 \cdot 20^{0.2}}{(120^{0.2} \cdot 1.75^{0.1} \cdot 0.10^{0.4} \cdot 16^{0.2} \cdot 4^0)} \cdot 1 = 316.5$$

mpm.

We calculate number of revolutions of a spindle  $n_{cal}$ :

$$n_{cal} = \frac{1000 \cdot V}{\pi \cdot d_{max}} = \frac{1000 \cdot 316.5}{3.14 \cdot 20} = 5039 \text{ rpm,}$$

Where  $d_{max}$  – the greatest diameter of working cutting edge relatively of axis of the rotating tool, mm.

In the technical passport of the machine tool we find the nearest smaller number of revolutions of a spindle (smaller - since even at insignificant increasing of cutting speed can result an essential reduction of cutting tool life  $T$ ):  $n_{pas} = 5000$  rpm. We calculate the **real** (specified or corrected) **cutting speed** at the accepted number of revolutions of a spindle by the formula (7.6):

$$V_r = \frac{\pi \cdot d \cdot n_{pas}}{1000} = \frac{3.14 \cdot 20 \cdot 5000}{1000} = 314 \text{ mpm.}$$

Calculation of tangential **component of cutting force**  $P_z$  [ N], at milling is done by the formula

$$P_z = \frac{10 \cdot C_p \cdot t^x \cdot s_z^y \cdot B^u \cdot z}{D^q \cdot n^w} \cdot K_{mp}. \quad (7.19)$$

Values of factor  $C_V$  and parameters of a degree for Face mill T15K6 and milling in processable constructional steel (steel 40X) are given in tab. 41 [1, page 291]:

$$C_p=825; \quad q = 1.3; \quad x=1; \quad y=0.75; \quad u=1.1; \quad w=0.2.$$

$K_{mp}$  - correction factor:

$$K_{mp} = K_{Mp} \times K_{Ip} \times K_{Itp}, \quad (7.20)$$

Where  $K_{Mp} = 75/\sigma_6$  - factor which is taking into account influence of quality of a processable material (durability) on cutting speed. For steel 40X strength of a stretching  $\sigma_6=75 \text{ kg} / \text{mm}^2$ , therefore  $K_{Mp} = 75/\sigma_6 = = 75/75 = 1$ ;

$K_{Ip}$  - factor which taking into account material of a cutting part. For a cutting tool from HSS P6M5  $K_{Ip} = 1$  [1, page 263, tab.6];

$K_{Itp} = 1$  - factor which is taking into account a blank surface condition [1, page 263, tab.5].

$$K_V = 1 \times 1 \times 1 = 1.$$

$$P_z = \frac{10 \cdot C_p \cdot t^x \cdot s_z^y \cdot B^u \cdot z}{D^q \cdot n^w} \cdot K_{mp} = \frac{10 \cdot 825 \cdot 1.75^1 \cdot 0.10^{0.75} \cdot 16^{1.1} \cdot 4}{20^{1.3} \cdot 5000^{0.2}} \cdot 1 = 803.4 \text{ [N].}$$

Other components of cutting force are calculated by the ratios [1, page 292, table 42]:

$$P_h : P_z = 0.6 - 0.8; P_h = P_z \cdot 0.8 = 803.4 \cdot 0.8 = 642.72 \text{ [N];}$$

$$P_v : P_z = 0.6 - 0.7; P_v = P_z \cdot 0.7 = 803.4 \cdot 0.7 = 562.4 \text{ [N];}$$

$$P_y : P_z = 0.3 - 0.4; P_y = P_z \cdot 0.4 = 803.4 \cdot 0.4 = 321.36 \text{ [N];}$$

$$P_x : P_z = 0.3 - 0.4; P_x = P_z \cdot 0.4 = 803.4 \cdot 0.4 = 321.36 \text{ [N];}$$

The **cutting power** in milling key slot 10H9 is calculated by the formula (7.5):

$$N = \frac{P_z \cdot V}{1020 \cdot 60} = \frac{803.4 \cdot 314}{1020 \cdot 60} = 4.12 \approx 4 \text{ kW.}$$

Where  $P_z$  - tangential component of cutting force (conterminous on a direction with a vector of cutting speed), N;  $V$  - cutting speed, mpm.

### 6.13 Calculation of cutting modes and forces at milling face Ø29.7h14

We choose the cutting tool by recommendations [2, page 450]: **Face mill** cutter Ø40 mm from solid cutter made of cemented carbide T15K6. At face milling for achievement of productive cutting modes the diameter of mill  $D$  should be more width of milling  $B$ , i.e.  $D = (1.25 \dots 1.5) \times B = 1.25 \times 29.7 = 37.1 \approx 40 \text{ mm}$ , and at machining of blanks their asymmetrical arrangement concerning a mill is obligatory: for carbon steel and alloyed steel blanks – their shift (displacement) in a direction of **incision** (start of cutting) of a mill tooth, than a small thickness of a cut off layer is provided in the cutting beginning; for heat-resistance and corrosion-resistance steel blanks – shift of blank towards an exit of a mill tooth from cutting, than minimum possible thickness of a cut off layer is provided at exiting of tooth from cutting. Non-observance of the specified rules leads to considerable decreasing of cutting tool life

Depth of cut of milling the face is  **$t=1.35 \text{ mm}$** .

**Feed rate:** according to the power of the machine tool 5-10 kw and inserts material T15K6  **$S=0.09-0.18 \text{ mm/tooth}$** ,

According to mill diameter  $D= \text{Ø}40 \text{ mm}$  and depth of cut  $t=1.35 \text{ mm}$

**$S=0.10-0.18 \text{ mm/tooth}$**

**Accepted feed rate  $S=0.15 \text{ mm/tooth}$**

**Cutting tool life-** with machining of steel for face mill  **$T=120 \text{ min}$**

The cutting **speed** at milling is calculated by the formula:

$$V = \frac{C_v \cdot D^q}{(T^m \cdot t^x \cdot s_z^y \cdot B^u \cdot z^p)} \cdot K_v, \quad (7.17)$$

Where:  $T$  - cutting tool life (at Face milling  $T=120$  minutes).

Values of factor  $C_V$  and parameters of a degree for a two-flute mills from HSS and milling with cooling in processable constructional steel (steel 40X) are given in tab. 39 [1, page 286]:

$$C_V=332; q = 0.2; x=0.1; y=0.4; u=0.2; p=0; m=0.2.$$

$K_V$  - correction factor:

$$K_V = K_{M_V} \times K_{I_{IV}} \times K_{II_V}, \quad (7.18)$$

Where  $K_{M_V} = 75/\sigma_\delta$  - factor which is taking into account influence of quality of a processable material (durability) on cutting speed. For steel 40X strength of a stretching  $\sigma_\delta=75 \text{ kg / mm}^2$ , therefore  $K_{M_V} = 75/\sigma_\delta = 75/75 = 1$ ;

$K_{I_{IV}}$  - factor which taking into account material of a cutting part.

For a cutting tool from HSS P6M5  $K_{I_{IV}}=1$  [1, page 263, tab.6];

$K_{II_V}=1$  - factor which is taking into account a blank surface condition [1, page 263, tab.5].

$$K_V = 1 \times 1 \times 1 = 1.$$

$$V = \frac{C_V \cdot D^q}{(T^m \cdot t^x \cdot s_z^y \cdot B^u \cdot z^p)} \cdot K_V = \frac{332 \cdot 40^{0.2}}{(120^{0.2} \cdot 1.35^{0.1} \cdot 0.15^{0.4} \cdot 29.7^{0.2} \cdot 4^0)} \cdot 1 = 280.3$$

mpm.

We calculate number of revolutions of a spindle  $n_{cal}$ :

$$n_{cal} = \frac{1000 \cdot V}{\pi \cdot d_{max}} = \frac{1000 \cdot 280.3}{3.14 \cdot 40} = 2231.6 \text{ rpm},$$

Where  $d_{max}$  – the greatest diameter of working cutting edge relatively of axis of the rotating tool, mm.

In the technical passport of the machine tool we find the nearest smaller number of revolutions of a spindle (smaller - since even at insignificant increasing of cutting speed can result an essential reduction of cutting tool life  $T$ ):  $n_{pas} = 2500 \text{ rpm}$ . We calculate the **real** (specified or corrected) **cutting speed** at the accepted number of revolutions of a spindle by the formula (7.6):

$$V_r = \frac{\pi \cdot d \cdot n_{pas}}{1000} = \frac{3.14 \cdot 40 \cdot 2500}{1000} = 314 \text{ mpm}.$$

Calculation of tangential **component of cutting force**  $P_z$  [ N], at milling is done by the formula

$$P_z = \frac{10 \cdot C_p \cdot t^x \cdot s_z^y \cdot B^u \cdot z}{D^q \cdot n^w} \cdot K_{mp}. \quad (7.19)$$

Values of factor  $C_V$  and parameters of a degree for Face mill T15K6 and milling in processable constructional steel (steel 40X) are given in tab. 41 [1, page 291]:

$$C_p=825; q = 1.3; x=1; y=0.75; u=1.1; w=0.2.$$

$K_{mp}$  - correction factor:

$$K_{mp} = K_{Mp} \times K_{Ip} \times K_{Hp}, \quad (7.20)$$

Where  $K_{Mp} = 75/\sigma_s$  - factor which is taking into account influence of quality of a processable material (durability) on cutting speed. For steel 40X strength of a stretching  $\sigma_s=75 \text{ kg / mm}^2$ , therefore  $K_{Mp} = 75/\sigma_s = 75/75 = 1$ ;

$K_{Hp}$  - factor which taking into account material of a cutting part.

For a cutting tool from HSS P6M5  $K_{Hp} = 1$  [1, page 263, tab.6];

$K_{Ip} = 1$  - factor which is taking into account a blank surface condition [1, page 263, tab.5].

$$K_V = 1 \times 1 \times 1 = 1.$$

$$P_z = \frac{10 \cdot C_p \cdot t^x \cdot s_z^y \cdot B^u \cdot z}{D^q \cdot n^w} \cdot K_{mp} = \frac{10 \cdot 825 \cdot 1.35^1 \cdot 0.15^{0.75} \cdot 29.7^{1.1} \cdot 4}{40^{1.3} \cdot 2500^{0.2}} \cdot 1 = 773.9 \text{ [N]}.$$

Other components of cutting force are calculated by the ratios [1, page 292, table 42]:

$$P_h : P_z = 0.6 - 0.8; \quad P_h = P_z \cdot 0.8 = 773.9 \cdot 0.8 = 619.12 \text{ [N]};$$

$$P_v : P_z = 0.6 - 0.7; \quad P_v = P_z \cdot 0.7 = 773.9 \cdot 0.7 = 541.73 \text{ [N]};$$

$$P_y : P_z = 0.3 - 0.4; \quad P_y = P_z \cdot 0.4 = 773.9 \cdot 0.4 = 309.56 \text{ [N]};$$

$$P_x : P_z = 0.3 - 0.4; \quad P_x = P_z \cdot 0.4 = 773.9 \cdot 0.4 = 309.56 \text{ [N]};$$

The **cutting power** at milling key slot 10H9 is calculated by the formula (7.5):

$$N = \frac{P_z \cdot V}{1020 \cdot 60} = \frac{773.9 \cdot 314}{1020 \cdot 60} = 3.97 \approx 4 \text{ kW}.$$

Where  $P_z$  - tangential component of cutting force (conterminous on a direction with a vector of cutting speed), N;  $V$  - cutting speed, mpm.

## 7. Technical fixing of laboriousness

In small-scale manufacture it is necessary to know the norm of Standard Time ( $H_t$ ) (or **floor-to-floor calculated time**  $t_{fc}$  or  $T_{fc}$ ) is the time of part manufacturing on one manufacturing operation taking into account time for preparation of machine tool, cutting tools and attachment for the work. This time is determined by the formula:

$$T_{fc} = T_f + \frac{T_p}{n_s}, \text{ min}, \quad (8.1)$$

Where  $T_p$  is a time for preparation of machine tool, cutting tools and attachment for the work;  $n_s$  is a set of detail for manufacturing in one set.

The norm of **floor-to-floor time**  $T_f$  (or **operation cycle per part (OCP)**  $t_{oc}$ ) is a piece time, or time of part manufacturing on one technological operation taking into account time for removing of chip and auxiliary time for operate with machine tool, but do not taking into account time for preparation of machine tool, cutting tools and attachment for the work. This time is determined by the formula:

$$T_f = T_{op} + T_s + T_r, \text{ min}, \quad (8.2)$$

Where:  $T_s$  is a time for service of machine tool (oiling, brushing, changing and sharpening of worn out cutters and e.s.);  $T_r$  is time for the rest. Generally  $T_s$  is equal 5% from  $T_{op}$ ,  $T_r$  is equal 6% from  $T_{op}$ , but sometimes  $T_s + T_r = 15\%$  from  $T_{op}$ . Further we will calculate  $T_s = 0.05 \cdot T_{op}$ ,  $T_r = 0.06 \cdot T_{op}$ ,

The norm of **operative time**  $T_{op}$  is determined by the formula:

$$T_{op} = T_d + T_{aux}, \text{ min}. \quad (8.3)$$

The norm of **direct time**  $T_d$  (or **machining time**  $t_m$ ) is time when the work feed rate is turn on for removing of chip from a surface. This time include the time for removing of chip from a surface and also the time for the cutting tool approach to the workpiece on the length  $l_{en}$  (or **under cutting** length  $l_{uc}$ ) in order to avoid collision in the beginning of machining, the time for cutting tool **over-travel** on the length  $l_{ov}$  (or **over-cutting** length  $l_{oc}$ ). Direct time is determined by the formula:

$$T_d = \frac{L}{n \cdot S_r}, \text{ min}, \quad (8.4)$$

where:  $L$  is a length of feed rate running, mm;  $n$  is quantity of revolutions of spindle in one minute, rpm;  $S_r$  is a feed rate, mmpr. For the milling and grinding operations generally feed rate for one minute is used for maintaining of feed rate of table:

$$S_m = S_r \cdot n, \text{ mmpm}.$$

Feed rate for one tooth  $S_z$ , mm per teeth, is written in handbook for milling operation. Minute feed rate can be calculated by the formula:

$$S_r = S_z \cdot z, \text{ mmpr}, \quad (8.6)$$

Where  $z$  is a quantity of teeth of milling cutter.

The **auxiliary time**  $T_{aux}$  is calculated by the formula

$$T_{aux} = T_l + T_c + T_o + T_m, \text{ min.} \quad (8.7)$$

where:  $T_l$  - is time for maintaining and fixing (loading) and unloading of a blank;  $T_c$  - is time for clamping of a blank;  $T_o$  - is time for operate with machine tool (changing cutting modes  $n$  and  $S$  if it is necessary, cutting tools (generally by revolving of tool holder), fasten moving the cutter close to the processable surface, turn on and turn off feed rate running;  $T_m$  - is time for measurements of manufactured part if it does not coincide with direct time.

Generally  $T_{aux}$  is determined with the handbook for auxiliary works, for each of them, but sometimes it can be calculated approximately as  $T_{aux} \approx 0.15 \cdot T_d$ , min.

Generally **direct** and **auxiliary time** is determined for each technological transition but **time for service** of machine tool and **time for the rest** is determined for whole technological operation.

We calculate direct, auxiliary, service of machine tool, rest, preparation time for each operation and write them in tab. 8.1.

### **Operation 1** (Face Milling)

(Cutting face  $\text{Ø}29.7\text{h}14$ )

The basic time is calculated by the formula (8.4). Generally length of cutting (length in the direction of a feed rate  $S$ ) is calculated by the formula:

$$L = d_{\text{blank}} + l_{uc} + l_{oc}, \text{ mm.} \quad (8.8)$$

On the basis of the recommendations [7, page 24] is accepted:  $l_{uc} + l_{oc} = 2$  mm.

$$T_d = \frac{L}{n \cdot S_r} = \frac{29.7 + 2}{2500 \cdot 0.15} = 0.08 \text{ min.}$$

The auxiliary time is determined by the formula (8.7):

$$T_{aux} = T_l + T_c + T_o + T_m,$$

Where  $T_l = 0.12 \text{ min}$  - time for maintaining and fixing (loading) and unloading of a blank [1, tab.5.6, page 199];

$T_c = 0.13 \text{ min}$  - time for clamping of a blank [1, tab.5.7, page 201];

$T_o = 0.1 \text{ min}$  - time for operate (management) of the machine tool [1, tab.5.8,

page 202];

$T_m = 0.1 \text{ min}$  - time for measurements [1, tab.5.16, page 209].

$$T_{aux} = T_l + T_c + T_o + T_m = 0.12 + 0.13 + 0.1 + 0.1 = 0.45 \text{ min.}$$

Operative time is determined by the formula:

$$T_{op} = T_d + T_{aux}, \text{ min.} \quad (8.9)$$

$$T_{op} = T_d + T_{aux} = 0.08 + 0.45 = 0.53 \text{ min.}$$

Time for service of one workplace is determined by the formula:

$$T_s = 0.05 \cdot T_{op} = 0.05 \cdot 0.53 = 0.02 \text{ min.} \quad (8.10)$$

Time of breaks for rest and personal needs is determined by the formula:

$$T_r = 0.06 \cdot T_{op} = 0.06 \cdot 0.53 = 0.031 \text{ min.} \quad (8.11)$$

Floor-to-floor time (piece time) is determined by the formula (8.2):

$$T_f = T_{op} + T_s + T_r = 0.53 + 0.02 + 0.031 = 0.58 \text{ min.}$$

Floor-to-floor calculation time is determined by the formula (8.1):

$$T_{fc} = T_f + \frac{T_p}{n_s} = 0.58 + \frac{18}{400} = 0.62 \text{ min}$$

Where  $T_p$  - preparation time,  $T_p = 18 \text{ min}$  [1, tab. 6.4, page 216];  $n_s$  - quantity of parts in a set,  $n_s = 400$  pieces.

### **Operation 02** (Rough Turning)

**Step1** (Cut surface ensuring size  $l=23\text{mm}$ )

Generally length of cutting is calculated by the formula (8.8):

$$L = l + l_{uc} + l_{oc} = 23 + 2 + 0 = 25 \text{ mm.}$$

The basic time is calculated by the formula (8.4).

$$T_d = \frac{L}{n \cdot S_r} = \frac{25}{2300 \cdot 0.43} = 0.02 \text{ min.},$$

Where  $S_r = 0.43 \text{ mmpr}$  - is adjusted feed rate on the gear box

The auxiliary time is determined by the formula (8.7):

$$T_{aux} = T_l + T_c + T_o + T_m = 0.12 + 0.13 + 0.1 + 0.2 = 0.55 \text{ min.}$$

Where  $T_l = 0.12 \text{ min}$  - time for maintaining and fixing (loading) and unloading of a blank [1, tab.5.6, page 199];

$T_c = 0.13 \text{ min}$  - time for clamping of a blank [1, tab.5.7, page 201];

$T_o = 0.1 \text{ min}$  - time for operate (management) of the machine tool [1, tab.5.8, page 202];

$T_m = 0.2 \text{ min}$  - time for measurements [1, tab.5.16, page 209].

**Step 2** (Cut surface ensuring size  $l=2.1 \text{ mm}$ )

The basic time is calculated by the formula (8.4).

$$T_d = \frac{L}{n \cdot S_r} = \frac{4.1}{1000 \cdot 0.5} = 0.0082 \text{ min.}$$

The auxiliary time is determined by the formula (8.7):

$$T_{aux} = T_l + T_c + T_o + T_m = 0 + 0 + 0.3 + 0.2 = 0.5 \text{ min.}$$

Where  $T_l = 0 \text{ min}$  - there is no time for maintaining and fixing (loading) and unloading of a blank (we have taken it into account in the second technological transition);

$T_c = 0 \text{ min}$  - there is no time for clamping of a blank (we have taken it into account in the second technological transition);

$T_o = 0.3 \text{ min}$  - time for operate (management)

$T_m = 0.2 \text{ min}$  - time for measurement

**Step 3** (cutting  $\varnothing 33.6 \text{ mm}$  ensuring length  $l=21 \text{ mm}$ )

The basic time is calculated by the formula (8.4).

$$T_d = \frac{L}{n \cdot S_r} = \frac{21}{1000 \cdot 0.43} = 0.048 \text{ min.}$$

The auxiliary time is determined by the formula (8.7):

$$T_{aux} = T_l + T_c + T_o + T_m = 0 + 0 + 0.3 + 0.2 = 0.5 \text{ min.}$$

Where  $T_l = 0 \text{ min}$  - there is no time for maintaining and fixing (loading) and unloading of a blank (we have taken it into account in the second technological transition);

$T_c = 0 \text{ min}$  - there is no time for clamping of a blank (we have taken it into account in the second technological transition);

$T_o = 0.3 \text{ min}$  - time for operate (management) of the machine tool

$T_m = 0.2 \text{ min}$  - time for measurement

**Step 4** (cutting  $\text{Ø}42$  length  $l=21\text{mm}$ )

The basic time is calculated by the formula (8.4).

$$T_d = \frac{L}{n \cdot S_r} = \frac{21+2}{1000 \cdot 0.43} = 0.05 \text{ min.}$$

The auxiliary time is determined by the formula (8.7):

$$T_{aux} = T_l + T_c + T_o + T_m = 0 + 0 + 0.3 + 0.1 = 0.4 \text{ min.}$$

Where  $T_o = 0.3 \text{ min}$  - time for operate (management) of the machine tool: to maintain a bore cutter, to move the bore cutter close to the right end face of the blank; to return on the feed rate from 0.43 mmpr to 0.21 mmpr; to adjust on the size III19.5H11; to turn on the feed rate [1, tab.5.8, page 202];

$T_m = 0.1 \text{ min}$  - time for measurement [1, tab.5.16, page 209].

**Step 5** (cutting chamfer size 2.5mm)

$$T_d = \frac{L}{n \cdot S_r} = \frac{2.5}{1000 \cdot 0.11} = 0.02 \text{ min.}$$

The auxiliary time is determined by the formula (8.7):

$$T_{aux} = T_l + T_c + T_o + T_m = 0 + 0 + 0.1 + 0.1 = 0.2 \text{ min.}$$

Where  $T_o = 0.1 \text{ min}$  - time for operate (management) of the machine tool: to move the bore cutter close to the right end face of the blank; it is need not to turn on the feed rate because we do it manually [1, tab.5.8, page 202];

$T_m = 0.1 \text{ min}$  - time for measurement [1, tab.5.16, page 209].

Operative time of **operation 02** is determined by the formula (8.9):

$$T_{op} = \sum(T_d + T_{aux}) = (0.02 + 0.55) + (0.008 + 0.5) + (0.048 + 0.5) + (0.05 + 0.4) + (0.02 + 0.2) = 2.29 \text{ min.}$$

Time for service of one workplace is determined by the formula (8.10):

$$T_s = 0.05 \cdot T_{op} = 0.05 \cdot 2.29 = 0.114 \text{ min.}$$

Time of breaks for rest and personal needs is determined by the formula (8.11):

$$T_r = 0.06 \cdot T_{op} = 0.06 \cdot 2.29 = 0.137 \text{ min.}$$

Floor-to-floor time (piece time) is determined by the formula (8.2):

$$T_f = T_{op} + T_s + T_r = 2.47 + 0.114 + 0.137 = 2.72 \text{ min.}$$

Floor-to-floor calculation time is determined by the formula (8.1):

$$T_{fc} = T_f + \frac{T_p}{n_s} = 2.72 + \frac{18}{500} = 2.75 \text{ min}$$

Where  $T_p$  - preparation time,  $T_p = 18 \text{ min}$  [1, tab. 6.4, page 216];  $n_s$  - quantity of parts in a set,  $n_s = 500 \text{ pieces}$ ;  $\frac{10000 \cdot 12}{240} = 500$ .

### **Operation 03** (Rough Turning)

#### **Step 1** (Cut $\varnothing 26.6$ ensuring size $l=21\text{mm}$ )

Generally length of cutting is calculated by the formula (8.8):

$$L = l + l_{uc} + l_{oc} = 21 + 2 + 0 = 23 \text{ mm.}$$

The basic time is calculated by the formula (8.4).

$$T_d = \frac{L}{n \cdot S_r} = \frac{23}{1000 \cdot 0.5} = 0.046 \text{ min.},$$

Where  $S_r = 0.5 \text{ mmpr}$  - is adjusted feed rate on the gear box

The auxiliary time is determined by the formula (8.7):

$$T_{aux} = T_l + T_c + T_o + T_m = 0.12 + 0.13 + 0.1 + 0.2 = 0.55 \text{ min.}$$

Where  $T_l = 0.12 \text{ min}$  - time for maintaining and fixing (loading) and unloading of a blank [1, tab.5.6, page 199];

$T_c = 0.13 \text{ min}$  - time for clamping of a blank [1, tab.5.7, page 201];

$T_o = 0.1 \text{ min}$  - time for operate (management) of the machine tool [1, tab.5.8, page 202];

$T_m = 0.2 \text{ min}$  - time for measurements [1, tab.5.16, page 209].

#### **Step 2** (Cut $\varnothing 33.58$ ensuring size $l=53.2\text{mm}$ )

The basic time is calculated by the formula (8.4).

$$T_d = \frac{L}{n \cdot S_r} = \frac{53.2}{1000 \cdot 0.43} = 0.12 \text{ min.}$$

The auxiliary time is determined by the formula (8.7):

$$T_{aux} = T_l + T_c + T_o + T_m = 0 + 0 + 0.3 + 0.2 = 0.5 \text{ min.}$$

Where  $T_l = 0 \text{ min}$  - there is no time for maintaining and fixing (loading) and unloading of a blank (we have taken it into account in the second technological transition);

$T_c = 0 \text{ min}$  - there is no time for clamping of a blank (we have taken it into account in the second technological transition);

$T_o = 0.3 \text{ min}$  - time for operate (management)

$T_m = 0.2 \text{ min}$  - time for measurement

Operative time of **operation 03** is determined by the formula (8.9):

$$T_{op} = \sum(T_d + T_{aux}) = (0.046 + 0.55) + (0.12 + 0.5) = 1.216 \text{ min}$$

Time for service of one workplace is determined by the formula (8.10):

$$T_s = 0.05 \cdot T_{op} = 0.05 \cdot 1.216 = 0.060 \text{ min.}$$

Time of breaks for rest and personal needs is determined by the formula (8.11):

$$T_r = 0.06 \cdot T_{op} = 0.06 \cdot 1.216 = 0.073 \text{ min.}$$

Floor-to-floor time (piece time) is determined by the formula (8.2):

$$T_f = T_{op} + T_s + T_r = 1.216 + 0.060 + 0.073 = 1.349 \text{ min.}$$

Floor-to-floor calculation time is determined by the formula (8.1):

$$T_{fc} = T_f + \frac{T_p}{n_s} = 1.349 + \frac{18}{500} = 1.38 \text{ min}$$

Where  $T_p$  - preparation time,  $T_p = 18 \text{ min}$  [1, tab. 6.4, page 216];  $n_s$  - quantity of parts in a set,  $n_s = 500 \text{ pieces}$ ;  $\frac{10000 \cdot 12}{240} = 500$ .

### **Operation 04** (Semi-Finish Turning)

#### **Step1** (Cut $\varnothing 25.8$ ensuring size $l=3\text{mm}$ )

Generally length of cutting is calculated by the formula (8.8):

$$L = l + l_{uc} + l_{oc} = 3 + 2 + 0 = 5 \text{ mm.}$$

The basic time is calculated by the formula (8.4).

$$T_d = \frac{L}{n \cdot S_r} = \frac{5}{4000 \cdot 0.07} = 0.017 \text{ min.,}$$

Where  $S_r = 0.07$  mmpr - is adjusted feed rate on the gear box

The auxiliary time is determined by the formula (8.7):

$$T_{aux} = T_l + T_c + T_o + T_m = 0.12 + 0.13 + 0.1 + 0.2 = 0.55 \text{ min.}$$

Where  $T_l = 0.12 \text{ min}$  - time for maintaining and fixing (loading) and unloading of a blank [1, tab.5.6, page 199];

$T_c = 0.13 \text{ min}$  - time for clamping of a blank [1, tab.5.7, page 201];

$T_o = 0.1 \text{ min}$  - time for operate (management) of the machine tool [1, tab.5.8, page 202];

$T_m = 0.2 \text{ min}$  - time for measurements [1, tab.5.16, page 209].

**Step 2** (Cut  $\varnothing 32.82$  ensuring size  $l=21 \text{ mm}$ )

The basic time is calculated by the formula (8.4).

$$T_d = \frac{L}{n \cdot S_r} = \frac{21}{3000 \cdot 0.07} = 0.1 \text{ min.}$$

The auxiliary time is determined by the formula (8.7):

$$T_{aux} = T_l + T_c + T_o + T_m = 0 + 0 + 0.3 + 0.2 = 0.5 \text{ min.}$$

Where  $T_l = 0 \text{ min}$  - there is no time for maintaining and fixing (loading) and unloading of a blank (we have taken it into account in the second technological transition);

$T_c = 0 \text{ min}$  - there is no time for clamping of a blank (we have taken it into account in the second technological transition);

$T_o = 0.3 \text{ min}$  - time for operate (management)

$T_m = 0.2 \text{ min}$  - time for measurement

**Step 3** (Cut chamfer size  $2.8 \text{ mm}$ )

The basic time is calculated by the formula (8.4).

$$T_d = \frac{L}{n \cdot S_r} = \frac{2.8}{3000 \cdot 0.11} = 0.0084 \text{ min.}$$

The auxiliary time is determined by the formula (8.7):

$$T_{aux} = T_l + T_c + T_o + T_m = 0 + 0 + 0.3 + 0.2 = 0.5 \text{ min.}$$

Where  $T_l = 0 \text{ min}$  - there is no time for maintaining and fixing (loading) and unloading of a blank (we have taken it into account in the second technological transition);

$T_c = 0 \text{ min}$  - there is no time for clamping of a blank (we have taken it into account in the second technological transition);

$T_o = 0.3 \text{ min}$  - time for operate (management) of the machine tool  
 $T_m = 0.2 \text{ min}$  - time for measurement

**Step 4** (Cut chamfer size 3.84mm)

The basic time is calculated by the formula (8.4).

$$T_d = \frac{L}{n \cdot S_r} = \frac{3.84 + 2}{3000 \cdot 0.11} = 0.017 \text{ min.}$$

The auxiliary time is determined by the formula (8.7):

$$T_{aux} = T_l + T_c + T_o + T_m = 0 + 0 + 0.3 + 0.1 \quad \text{min.}$$

Where  $T_o = 0.3 \text{ min}$  - time for operate (management) of the machine tool  
 $T_m = 0.1 \text{ min}$  - time for measurement [1, tab.5.16, page 209].

**Step 5** (Cut chamfer size 3.17mm)

$$T_d = \frac{L}{n \cdot S_r} = \frac{3.17 + 2}{3000 \cdot 0.11} = 0.015 \text{ min.}$$

The auxiliary time is determined by the formula (8.7):

$$T_{aux} = T_l + T_c + T_o + T_m = 0 + 0 + 0.1 + 0.1 = 0.2 \text{ min.}$$

Where  $T_o = 0.1 \text{ min}$  - time for operate (management) of the machine tool: to move the bore cutter close to the right end face of the blank; it is need not to turn on the feed rate because we do it manually [1, tab.5.8, page 202];  
 $T_m = 0.1 \text{ min}$  - time for measurement [1, tab.5.16, page 209].

Operative time of **operation 04** is determined by the formula (8.9):

$$T_{op} = \sum(T_d + T_{aux}) = (0.017 + 0.55) + (0.1 + 0.5) + (0.0084 + 0.5) + (0.017 + 0.4) + (0.015 + 0.2) = 2.3 \text{ min.}$$

Time for service of one workplace is determined by the formula (8.10):

$$T_s = 0.05 \cdot T_{op} = 0.05 \cdot 2.3 = 0.115 \text{ min.}$$

Time of breaks for rest and personal needs is determined by the formula (8.11):

$$T_r = 0.06 \cdot T_{op} = 0.06 \cdot 2.3 = 0.138 \text{ min.}$$

Floor-to-floor time (piece time) is determined by the formula (8.2):

$$T_f = T_{op} + T_s + T_r = 2.3 + 0.115 + 0.138 = 2.55 \text{ min.}$$

Floor-to-floor calculation time is determined by the formula (8.1):

$$T_{fc} = T_f + \frac{T_p}{n_s} = 2.55 + \frac{18}{500} = 2.58 \text{ min}$$

Where  $T_p$  - preparation time,  $T_p = 18 \text{ min}$  [1, tab. 6.4, page 216];  $n_s$  - quantity of parts in a set,  $n_s = 500 \text{ pieces}$ ;  $\frac{10000 \cdot 12}{240} = 500$ .

### **Operation 05** (Semi-Finish Turning)

**Step 1** (Cut  $\varnothing 25.8$  ensuring size  $l=22.1 \text{ mm}$ )

Generally length of cutting is calculated by the formula (8.8):

$$L = l + l_{uc} + l_{oc} = 22.1 + 2 + 0 = 24.1 \text{ mm.}$$

The basic time is calculated by the formula (8.4).

$$T_d = \frac{L}{n \cdot S_r} = \frac{24.1}{4000 \cdot 0.07} = 0.086 \text{ min.},$$

Where  $S_r = 0.07 \text{ mmpr}$  - is adjusted feed rate on the gear box

The auxiliary time is determined by the formula (8.7):

$$T_{aux} = T_l + T_c + T_o + T_m = 0.12 + 0.13 + 0.1 + 0.2 = 0.55 \text{ min.}$$

Where  $T_l = 0.12 \text{ min}$  - time for maintaining and fixing (loading) and unloading of a blank [1, tab.5.6, page 199];

$T_c = 0.13 \text{ min}$  - time for clamping of a blank [1, tab.5.7, page 201];

$T_o = 0.1 \text{ min}$  - time for operate (management) of the machine tool [1, tab.5.8, page 202];

$T_m = 0.2 \text{ min}$  - time for measurements [1, tab.5.16, page 209].

**Step 2** (Cut  $\varnothing 32.7$  ensuring size  $l=53.1 \text{ mm}$ )

The basic time is calculated by the formula (8.4).

$$T_d = \frac{L}{n \cdot S_r} = \frac{53.1}{3000 \cdot 0.07} = 0.25 \text{ min.}$$

The auxiliary time is determined by the formula (8.7):

$$T_{aux} = T_l + T_c + T_o + T_m = 0 + 0 + 0.3 + 0.2 = 0.5 \text{ min.}$$

Where  $T_l = 0 \text{ min}$  - there is no time for maintaining and fixing (loading) and unloading of a blank (we have taken it into account in the second technological transition);

$T_c = 0 \text{ min}$  - there is no time for clamping of a blank (we have taken it into account in the second technological transition);

$T_o = 0.3 \text{ min}$  - time for operate (management)

$T_m = 0.2 \text{ min}$  - time for measurement

**Step 3** (Cut chamfer size 2.8mm)

The basic time is calculated by the formula (8.4).

$$T_d = \frac{L}{n \cdot S_r} = \frac{2.8}{3000 \cdot 0.11} = 0.0084 \text{ min.}$$

The auxiliary time is determined by the formula (8.7):

$$T_{aux} = T_l + T_c + T_o + T_m = 0 + 0 + 0.3 + 0.2 = 0.5 \text{ min.}$$

Where  $T_l = 0 \text{ min}$  - there is no time for maintaining and fixing (loading) and unloading of a blank (we have taken it into account in the second technological transition);

$T_c = 0 \text{ min}$  - there is no time for clamping of a blank (we have taken it into account in the second technological transition);

$T_o = 0.3 \text{ min}$  - time for operate (management) of the machine tool

$T_m = 0.2 \text{ min}$  - time for measurement

**Step 4** (Cut chamfer size 3.7mm)

The basic time is calculated by the formula (8.4).

$$T_d = \frac{L}{n \cdot S_r} = \frac{3.7+2}{3000 \cdot 0.11} = 0.017 \text{ min.}$$

The auxiliary time is determined by the formula (8.7):

$$T_{aux} = T_l + T_c + T_o + T_m = 0 + 0 + 0.3 + 0.1 = 0.4 \text{ min.}$$

Where  $T_o = 0.3 \text{ min}$  - time for operate (management) of the machine tool

$T_m = 0.1 \text{ min}$  - time for measurement [1, tab.5.16, page 209].

**Step 5** (Cut chamfer size 3.16mm)

$$T_d = \frac{L}{n \cdot S_r} = \frac{3.16+2}{3000 \cdot 0.11} = 0.015 \text{ min.}$$

The auxiliary time is determined by the formula (8.7):

$$T_{aux} = T_l + T_c + T_o + T_m = 0 + 0 + 0.1 + 0.1 = 0.2 \text{ min.}$$

Where  $T_o. = 0.1 \text{ min}$  - time for operate (management) of the machine tool: to move the bore cutter close to the right end face of the blank; it is need not to turn on the feed rate because we do it manually [1, tab.5.8, page 202];  
 $T_m = 0.1 \text{ min}$  - time for measurement [1, tab.5.16, page 209].

Operative time of **operation 05** is determined by the formula (8.9):

$$T_{op} = \sum(T_d + T_{awx}) = (0.086 + 0.55) + (0.25 + 0.5) + (0.0084 + 0.5) + (0.017 + 0.4) + (0.015 + 0.2) = 2.52 \text{ min.}$$

Time for service of one workplace is determined by the formula (8.10):

$$T_s = 0.05 \cdot T_{op} = 0.05 \cdot 2.52 = 0.126 \text{ min.}$$

Time of breaks for rest and personal needs is determined by the formula (8.11):

$$T_r = 0.06 \cdot T_{op} = 0.06 \cdot 2.52 = 0.151 \text{ min.}$$

Floor-to-floor time (piece time) is determined by the formula (8.2):

$$T_f = T_{op} + T_s + T_r = 2.52 + 0.126 + 0.151 = 2.8 \text{ min.}$$

Floor-to-floor calculation time is determined by the formula (8.1):

$$T_{fc} = T_f + \frac{T_p}{n_s} = 2.8 + \frac{18}{500} = 2.83 \text{ min}$$

Where  $T_p$  - preparation time,  $T_p = 18 \text{ min}$  [1, tab. 6.4, page 216];  $n_s$  - quantity of parts in a set,  $n_s = 500 \text{ pieces}$ ;  $\frac{10000 \cdot 12}{240} = 500$ .

### **Operation 06** (Milling Key slot size $l=43\text{mm}$ )

Generally length of cutting is calculated by the formula (8.8):

$$L = l + l_{uc} + l_{oc} = 43 + 5 + 0 = 48 \text{ mm.}$$

The basic time is calculated by the formula (8.4).

$$T_d = \frac{L}{n \cdot S_r} = \frac{48}{400 \cdot 0.024} = 5 \text{ min.},$$

Where  $S_r = 0.024 \text{ mm/min}$  - is adjusted feed rate on the gear box

The auxiliary time is determined by the formula (8.7):

$$T_{aux} = T_l + T_c + T_o + T_m = 0.12 + 0.13 + 0.1 + 0.2 = 0.55 \text{ min.}$$

Where  $T_l = 0.12 \text{ min}$  - time for maintaining and fixing (loading) and unloading of a blank [1, tab.5.6, page 199];

$T_c = 0.13 \text{ min}$  - time for clamping of a blank [1, tab.5.7, page 201];

$T_o = 0.1 \text{ min}$  - time for operate (management) of the machine tool [1, tab.5.8, page 202];

$T_m = 0.2 \text{ min}$  - time for measurements [1, tab.5.16, page 209].

Operative time of **operation 06** is determined by the formula (8.9):

$$T_{op} = \sum(T_d + T_{aux}) = (5 + 0.55) = 5.55 \text{ min.}$$

Time for service of one workplace is determined by the formula (8.10):

$$T_s = 0.05 \cdot T_{op} = 0.05 \cdot 5.55 = 0.277 \text{ min.}$$

Time of breaks for rest and personal needs is determined by the formula (8.11):

$$T_r = 0.06 \cdot T_{op} = 0.06 \cdot 5.55 = 0.33 \text{ min.}$$

Floor-to-floor time (piece time) is determined by the formula (8.2):

$$T_f = T_{op} + T_s + T_r = 5.55 + 0.277 + 0.33 = 6.157 \text{ min.}$$

Floor-to-floor calculation time is determined by the formula (8.1):

$$T_{fc} = T_f + \frac{T_p}{n_s} = 6.157 + \frac{18}{500} = 6.19 \text{ min}$$

Where  $T_p$  - preparation time,  $T_p = 18 \text{ min}$  [1, tab. 6.4, page 216];  $n_s$  - quantity of parts in a set,  $n_s = 500$  pieces;  $\frac{10000 \cdot 12}{240} = 500$ .

### **Operation 07** (Threading)

**Step1** (Cut thread M12-8g size  $l=22\text{mm}$ )

Generally length of cutting is calculated by the formula (8.8):

$$L = l + l_{uc} + l_{oc} = 22 + 2 + 0 = 24 \text{ mm.}$$

The basic time is calculated by the formula (8.4).

$$T_d = \frac{L}{n \cdot S_r} = \frac{24}{1000 \cdot 0.11} = 0.21 \text{ min.},$$

Where  $S_r = 0.11$  mmpr - is adjusted feed rate “manually”

$$T_{aux} = T_l + T_c + T_o + T_m = 0.12 + 0.13 + 0.1 + 0.2 = 0.55 \text{ min.}$$

Where  $T_l = 0.12 \text{ min}$  - time for maintaining and fixing (loading) and unloading of a blank [1, tab.5.6, page 199];

$T_c = 0.13 \text{ min}$  - time for clamping of a blank [1, tab.5.7, page 201];

$T_o = 0.1 \text{ min}$  - time for operate (management) of the machine tool [1, tab.5.8, page 202];

$T_m = 0.2 \text{ min}$  - time for measurements [1, tab.5.16, page 209].

Operative time of **operation 05** is determined by the formula (8.9):

$$T_{op} = \sum(T_d + T_{aux}) = (0.21 + 0.55) = 0.76 \text{ min.}$$

Time for service of one workplace is determined by the formula (8.10):

$$T_s = 0.05 \cdot T_{op} = 0.05 \cdot 0.76 = 0.038 \text{ min.}$$

Time of breaks for rest and personal needs is determined by the formula (8.11):

$$T_r = 0.06 \cdot T_{op} = 0.06 \cdot 0.76 = 0.045 \text{ min.}$$

Floor-to-floor time (piece time) is determined by the formula (8.2):

$$T_f = T_{op} + T_s + T_r = 0.76 + 0.038 + 0.045 = 0.84 \text{ min.}$$

Floor-to-floor calculation time is determined by the formula (8.1):

$$T_{fc} = T_f + \frac{T_p}{n_s} = 0.84 + \frac{18}{500} = 0.876 \text{ min}$$

Where  $T_p$  - preparation time,  $T_p = 18 \text{ min}$  [1, tab. 6.4, page 216];  $n_s$  - quantity of parts in a set,  $n_s = 500$  pieces;  $\frac{10000 \cdot 12}{240} = 500$ .

### **Operation 09** (Grinding operation)

#### **Step 1** (Cut Ø25 ensuring size l=10mm)

Generally length of cutting is calculated by the formula (8.8):

$$L = l + l_{uc} + l_{oc} = 10 + 2 + 0 = 12 \text{ mm.}$$

The basic time is calculated by the formula (8.4).

$$T_d = \frac{L}{n \cdot S_r} \cdot N = \frac{12}{250 \cdot 12.5} \cdot 8 = 0.030 \text{ min.}$$

Where

N- Number of passes = 8

$S_r = 0.07$  mmpr - is adjusted feed rate on the gear box

The auxiliary time is determined by the formula (8.7):

$$T_{aux} = T_l + T_c + T_o + T_m = 0.12 + 0.13 + 0.1 + 0.2 = 0.55 \text{ min.}$$

Where  $T_l = 0.12 \text{ min}$  - time for maintaining and fixing (loading) and unloading of a blank [1, tab.5.6, page 199];

$T_c = 0.13 \text{ min}$  - time for clamping of a blank [1, tab.5.7, page 201];

$T_o = 0.1 \text{ min}$  - time for operate (management) of the machine tool [1, tab.5.8, page 202];

$T_m = 0.2 \text{ min}$  - time for measurements [1, tab.5.16, page 209].

#### **Step 2** (Cut Ø32s7 ensuring size l=21mm)

The basic time is calculated by the formula (8.4).

$$T_d = \frac{L}{n \cdot S_r} = \frac{21+2}{200 \cdot 12.5} \cdot 8 = 0.073 \text{ min.}$$

The auxiliary time is determined by the formula (8.7):

$$T_{aux} = T_l + T_c + T_o + T_m = 0 + 0 + 0.3 + 0.2 = 0.6 \text{ min.}$$

Where  $T_l = 0 \text{ min}$  - there is no time for maintaining and fixing (loading) and unloading of a blank (we have taken it into account in the second technological transition);

$T_c = 0 \text{ min}$  - there is no time for clamping of a blank (we have taken it into account in the second technological transition);

$T_o = 0.3 \text{ min}$  - time for operate (management)

$T_m = 0.3 \text{ min}$  - time for measurement

Operative time of **operation 09** is determined by the formula (8.9):

$$T_{op} = \sum(T_d + T_{awx}) = (0.030 + 0.55) + (0.073 + 0.6) = 1.25 \text{ min.}$$

Time for service of one workplace is determined by the formula (8.10):

$$T_s = 0.05 \cdot T_{op} = 0.05 \cdot 1.25 = 0.0625 \text{ min.}$$

Time of breaks for rest and personal needs is determined by the formula (8.11):

$$T_r = 0.06 \cdot T_{op} = 0.06 \cdot 1.25 = 0.075 \text{ min.}$$

Floor-to-floor time (piece time) is determined by the formula (8.2):

$$T_f = T_{op} + T_s + T_r = 1.25 + 0.0625 + 0.075 = 1.387 \text{ min.}$$

Floor-to-floor calculation time is determined by the formula (8.1):

$$T_{fc} = T_f + \frac{T_p}{n_s} = 1.387 + \frac{18}{500} = 1.423 \text{ min}$$

Where  $T_p$  - preparation time,  $T_p = 18 \text{ min}$  [1, tab. 6.4, page 216];  $n_s$  - quantity of parts in a set,  $n_s = 500$  pieces;  $\frac{10000 \cdot 12}{240} = 500$ .

### **Operation 10** (Grinding operation)

**Step1** (Cut  $\varnothing 25$  ensuring size  $l=23\text{mm}$ )

Generally length of cutting is calculated by the formula (8.8):

$$L = l + l_{uc} + l_{oc} = 23 + 2 + 0 = 25 \text{ mm.}$$

The basic time is calculated by the formula (8.4).

$$T_d = \frac{L}{n \cdot S_r} \cdot N = \frac{25}{250 \cdot 12.5} \cdot 8 = 0.064 \text{ min.}$$

Where

N- Number of passes = 8

$S_r = 0.07 \text{ mmpr}$  - is adjusted feed rate on the gear box.

The auxiliary time is determined by the formula (8.7):

$$T_{aux} = T_l + T_c + T_o + T_m = 0.12 + 0.13 + 0.1 + 0.2 = 0.55 \text{ min.}$$

Where  $T_l = 0.12 \text{ min}$  - time for maintaining and fixing (loading) and unloading of a blank [1, tab.5.6, page 199];

$T_c = 0.13 \text{ min}$  - time for clamping of a blank [1, tab.5.7, page 201];

$T_o = 0.1 \text{ min}$  - time for operate (management) of the machine tool [1, tab.5.8, page 202];

$T_m = 0.2 \text{ min}$  - time for measurements [1, tab.5.16, page 209].

**Step 2** (Cut  $\text{Ø}32\text{g}6$  ensuring size  $l=53\text{mm}$ )

The basic time is calculated by the formula (8.4).

$$T_d = \frac{L}{n \cdot S_r} = \frac{53+2}{200 \cdot 12.5} \cdot 8 = 0.176 \text{ min.}$$

The auxiliary time is determined by the formula (8.7):

$$T_{aux} = T_l + T_c + T_o + T_m = 0 + 0 + 0.3 + 0.2 = 0.6 \text{ min.}$$

Where  $T_l = 0 \text{ min}$  - there is no time for maintaining and fixing (loading) and unloading of a blank (we have taken it into account in the second technological transition);

$T_c = 0 \text{ min}$  - there is no time for clamping of a blank (we have taken it into account in the second technological transition);

$T_o = 0.3 \text{ min}$  - time for operate (management)

$T_m = 0.3 \text{ min}$  - time for measurement

Operative time of **operation 09** is determined by the formula (8.9):

$$T_{op} = \sum(T_d + T_{aux}) = (0.064 + 0.55) + (0.176 + 0.6) = 1.39 \text{ min.}$$

Time for service of one workplace is determined by the formula (8.10):

$$T_s = 0.05 \cdot T_{op} = 0.05 \cdot 1.39 = 0.0695 \text{ min.}$$

Time of breaks for rest and personal needs is determined by the formula (8.11):

$$T_r = 0.06 \cdot T_{op} = 0.06 \cdot 1.39 = 0.083 \text{ min.}$$

Floor-to-floor time (piece time) is determined by the formula (8.2):

$$T_f = T_{op} + T_s + T_r = 1.39 + 0.0695 + 0.083 = 1.54 \text{ min.}$$

Floor-to-floor calculation time is determined by the formula (8.1):

$$T_{fc} = T_f + \frac{T_p}{n_s} = 1.54 + \frac{18}{500} = 1.57 \text{ min}$$

Where  $T_p$  - preparation time,  $T_p = 18 \text{ min}$  [1, tab. 6.4, page 216];  $n_s$  - quantity of parts in a set,  $n_s = 500 \text{ pieces}$ ;  $\frac{10000 \cdot 12}{240} = 500$ .

The calculations of the basic time for different operations are written in table 8.1.

Table 8.1 Calculation of laboriousness of shaft manufacturing

Number		Modes		Length L, mm/ dia-meter d, mm	Time, min				T <sub>op</sub> , min	T <sub>s</sub> , min	T <sub>r</sub> , min	T <sub>f</sub> , min	T <sub>p</sub> , min	T <sub>fc</sub> , min
Op.	stp.	n, rpm	S, mmpr		T <sub>d</sub>	T <sub>i</sub> + T <sub>fast</sub>	T <sub>o</sub>	T <sub>m</sub>						
<b>1</b>	<b>2</b>	<b>3</b>	<b>4</b>	<b>5</b>	<b>6</b>	<b>7</b>	<b>8</b>	<b>9</b>	<b>10</b>	<b>11</b>	<b>12</b>	<b>13</b>	<b>14</b>	<b>15</b>
<b>01</b>	1	2500	0.15	29.7	0.08	0.25	0.1	0.1	0.53	0.02	0.03	0.58	18	<b>0.62</b>
<b>02</b>	1	2300	0.43	25	0.02	0.25	0.1	0.2	2.29	0.11	0.13	2.72	18	<b>2.75</b>
	2	1000	0.5	4.1	0.00	---	0.3	0.2						
	3	1000	0.43	21	0.04	---	0.3	0.2						
	4	1000	0.43	21	0.05	---	0.3	0.1						
	5	1000	0.11	2.5	0.02	---	0.1	0.1						
<b>03</b>	1	1000	0.5	21	0.04	0.25	0.1	0.2	1.21	0.06	0.07	1.35	18	<b>1.38</b>
	2	1000	0.43	53.2	0.12	---	0.3	0.2						
<b>04</b>	1	4000	0.07	3	0.01	0.25			2.3	0.11	0.14	2.55	18	<b>2.58</b>
	2	3000	0.07	21	0.1	---	0.3	0.2						
	3	3000	0.11	2.8	0.00		0.3	0.2						
	4	3000	0.11	3.84	0.01		0.3	0.1						
	5	3000	0.11	3.17	0.01		0.1	0.1						
<b>05</b>	1	4000	0.07	22.1	0.08	0.25	0.1	0.2	2.52	0.12	0.15	2.8	18	<b>2.83</b>
	2	3000	0.07	53.1	0.25		0.3	0.2						
	3	3000	0.11	2.8	0.00		0.3	0.2						
	4	3000	0.11	3.7	0.01		0.3	0.1						

	5	3000	0.11	3.16	0.01 5		0.1	0.1						
<b>06</b>	1	400	0.024	43	5	0.25	0.1	0.2	5.55	0.27	0.3	6.15	18	<b>6.19</b>
<b>07</b>	1	1000	0.11	22	0.21	0.25	0.1	0.2	0.76	0.03 8	0.04 5	0.84	18	<b>0.87</b>
<b>08</b>		Quenching HRC 50...55 a set of parts (200 pieces) by heating at temperature 850...890°C during 60 min and then cooling in oil Industrial 40 at temperature 20...30°C							0.4	0.02	0.02	0.44	30	<b>0.52</b>
<b>09</b>	1	250	12.5	10	0.03	0.25	0.1	0.2	1.25	0.06 2	0.07 5	1.38	18	<b>1.4</b>
	2	200	12.5	21	0.07		0.3	0.3						
<b>10</b>	1	250	12.5	23	0.06 4	0.25	0.1	0.2	1.39	0.07	0.08	1.54	18	<b>1.57</b>
	2	200	12.5	53	0.17	---	0.3	0.3						

**Total calculated floor-to-floor time  $T_{fct}$  (or total Standard time  $H_{tt}$ ) of technological process is calculated:**

$$\sum T_{fc} = 0.62 + 2.75 + 1.38 + 2.58 + 2.83 + 6.19 + 0.87 + 0.52 + 1.4 + 1.57 = \mathbf{20.7 \text{ min.}}$$

## 8. Design Section

Стр. №	Герб. примен.											
Взам. инв. №	Инв. № дубл.											Год. и дата
Год. и дата	Год. и дата	Год.	Дата	Лист	Масса	Масштаб						
Инв. № подл.	Разраб.	Прое.	Т.контр.	Лист	Листов	1:1					1	
Н.контр.	Утв.											

Копировал Формат A4

The aim is to design a suitable attachment for a mechanical part which we are going to manufacture. We will mill both ends of the shaft, which will be lying in two prisms. The angle of the prisms is 90 degrees. On the scheme is shown the pneumatic attachment of the shaft gripped in prisms.

We have to calculate the required force for our attachment and also the force we will get by pneumatic mechanism. Piston force has to be much higher than required force.

**The mechanism is as follows:**

When the lower valve is on, the air pressure will force the piston to move in the upper direction making the mechanical linkages to release workpiece, while when the lower valve is on, the air pressure forces the piston to move in the lower direction forcing the lever to push on the workpiece and therefor clamp it.

**1. Given and chosen:**

Diameters required for calculations: force of cut, force of clamping, force on rod of piston, diameter of piston.

Coefficient of friction between workpiece and surfaces of V-block  $f = 0,1$

Feed rate:  $S_z = 0,024$  mm/tooth

Ultimate tensile strength of workpiece material (steel 40X):  $\sigma_{uts} = 1000$  MPa

Pressure in cylinder of pneumatic mechanism:  $p = 0,4$  MPa

**2. Calculations:**

Diameter of a milling cutter:

We are choosing a milling cutter two flute  **$\phi 10$ mm**

Diameter -  $D = 10$  mm

Teeth -  $Z = 2$

*cutting tool material: high speed steel P6M5*

Cutting speed:

$$v = \frac{c_v * D^{cv}}{T^m * t^x * S_z^y * B^u * Z^p} * K_v = \frac{12 * 10^{0,3}}{80^{0,26} * 5.69^{0,3} * 0,024^{0,25} * 5^0 * 2^0} * 1$$

$$= 11.5 \text{ m/min}$$

Frequency of revolution:

$$n_{\text{calc}} = \frac{1000 * v}{\pi * d_{\text{mill}}} = \frac{1000 * 11}{\pi * 10} = 366 \text{ r/min}$$

$$n_{\text{acc}} = 400 \text{ r/min}$$

Feed rate of milling cutter:

$$S_m = S_z * Z * n_{\text{acc}} = 0,024 * 2 * 400 = 19.2 \text{ mm/min}$$

Force in z axis:

$$P_z = \frac{10 * c_p * t^x * S_z^y * B^u * Z}{D^{cv} * n^w} * K_{\text{mp}}$$
$$= \frac{10 * 68.2 * 5.69^{0,86} * 0,024^{0,72} * 5^1 * 2}{10^{0,86} * 400^0} * 1 = 286 \text{ N}$$

Longitudinal force:

$$P_h = P_z * 0.6 = 286 * 0.4 = 114.4 \text{ N}$$

Normal force:

$$N = \frac{P_h * K_{\text{saf}}}{2 * f} = \frac{171.7 * 2.5}{2 * 0.1} = 1430 \text{ N}$$

Where-  $P_h$  – Longitudinal force

$K_{\text{saf}}$  – Safety factor = 2.5

$f$  – Friction coefficient = 0.1

Torque equation:

$$2N * l_2 = Q_{\text{req}} * l_1$$
$$Q_{\text{req}} = \frac{2N * l_2}{l_1} = \frac{2 * 1430 * 90}{60} = 4290 \text{ N}$$

Pascal law in cylinders (pressure in cylinder):

$$Q_{\text{piston}} = \left( \frac{D^2 * \pi}{4} - \frac{d^2 * \pi}{4} \right) * p$$

$$\text{From there we get } D^2 = \frac{Q * 4}{\pi * p} + d^2; D = \sqrt{\frac{Q * 4}{\pi * p} + d^2} = \sqrt{\frac{4290 * 4}{\pi * 0.4 * 10^6} + 0.03^2} =$$
$$= 0.120 \text{ M} = 120 \text{ mm} \text{ We round it to } 130 \text{ mm}$$

Check:

$$\left( \frac{0,13^2 * \pi}{4} - \frac{0,03^2 * \pi}{4} \right) * 0,4 * 10^6 = 5024 \text{ N}$$

$$Q_{\text{piston}} \gg Q_{\text{req}} \quad 5024 \gg 4290$$

### 3. Conclusion:

We figured out that the force of pistons ( $Q_{\text{piston}}$ ) which we are going to get is much higher than the required force ( $Q_{\text{req}}$ ). Although the piston force is much higher we are not going to change parameters of pneumatic mechanism. The reason is that if there will be some oil the coefficient of friction will dramatically change and required force will be higher. Also our attachment might be used for a harder material that shown in calculations.

## ЗАДАНИЕ ДЛЯ РАЗДЕЛА «ФИНАНСОВЫЙ МЕНЕДЖМЕНТ, РЕСУРСОЭФФЕКТИВНОСТЬ И РЕСУРСОСБЕРЕЖЕНИЕ»

Студенту:

Группа	ФИО
8ЛЗИ	Таха Мохамед Халед Мохамед

Институт	ИК	Кафедра	ТМСПР
Уровень образования	Бакалавр	Направление/специальность	машиностроение

### Исходные данные к разделу «Финансовый менеджмент, ресурсоэффективность и ресурсосбережение»:

<i>1. Стоимость ресурсов для изготовления детали «вала редуктора»</i>	<i>1. Стоимость основных материалов определить на основе данных прайс-листов организаций-продавцов материалов 2. Часовые тарифные ставки по разрядам работ: 1 разряд - 40 руб./час. 2 разряд – 51 руб./час. 3 разряд – 65 руб./час. 4 разряд – 82.96 руб./час. 5 разряд – 105,81 руб./час. 6 разряд – 135 руб./час. Разряды работ определить исходя из ЕТКС, раздел «Механическая обработка металлов и других материалов» 3. Тариф на электроэнергию – 5.8 руб./кВт.ч.</i>
<i>3. Нормы и нормативы расходования ресурсов</i>	<i>Для расчетов принять следующие пределы нормативов расходования ресурсов: -коэффициент транспортно-заготовительных расходов - 0.06 -затраты на содержание рабочих занятых обслуживанием машин и оборудования, непосредственно не занятых изготовлением продукции - 40 % от полной зарплаты и отчислений от нее основных рабочих</i>

	<p>-затраты на материалы, расходуемых для обеспечения работы оборудования, принимается - 20% от величины амортизации</p> <p>-затраты на ремонт оборудования -100–120% от основной зарплаты основных рабочих.</p> <p>-общецеховые расходы - 50 – 80 %, от основной зарплаты основных рабочих</p> <p>-общехозяйственные расходы -50% от основной зарплаты основных рабочих.</p> <p>-расходы на реализацию - 1% от производственной себестоимости</p>
4. Используемая система налогообложения, ставки налогов, отчислений, дисконтирования и кредитования	<p>Ставка отчислений на социальные нужды – 30% от ФОТ</p> <p>Ставка отчислений в фонд социального страхования от несчастных случаев на производстве – 0.7% от ФОТ</p> <p>Налог на добавленную стоимость – 18% от цены изделия.</p>

**Перечень вопросов, подлежащих исследованию, проектированию и разработке:**

1. Расчет себестоимости изготовления детали «вала редуктора»	<p>1.Провести расчет затрат на основные и вспомогательные материалы (за вычетом возвратных отходов)</p> <p>2.Провести расчет затрат на основную и дополнительную заработную плату основных производственных рабочих, отчислений на социальные нужды.</p> <p>3.Провести расчет величины расходов на содержание и эксплуатацию оборудования.</p> <p>4. Провести расчет величины общецеховых, общехозяйственных, внепроизводственных расходов.</p> <p>5.Провести расчет себестоимости.</p>
2. Расчет цены детали «вала редуктора» с НДС	<p>Расчет произвести с использованием нормативного метода ценообразования. Норму рентабельности принять в пределах 5-20%</p>

**Перечень графического материала**(с точным указанием обязательных чертежей):

1. Калькуляция себестоимости детали «вала редуктора»

**Дата выдачи задания для раздела по линейному графику**

**Задание выдал консультант:**

Должность	ФИО	Ученая степень, звание	Подпись	Дата
Зав каф. Менеджмент	Чистякова Н.О.			

**Задание принял к исполнению студент:**

Группа	ФИО	Подпись	Дата
8ЛЗИ	Таха Мохамед Халед Мохамед		

## 9. Economic section

### Plan of the project

In this project we planned to make the project's graph, the line graph can be shown in table 1.

**Table 1** – Monthly project plan

№	Work name	Time (day)	Starting date	Finishing date	Done by
1	Given work plan	2	30.01.2017	31.01.2017	Supervisor
2	Sources research	7	01.02.2017	07.02.2017	Student
3	Definition of manufacturing type	4	08.02.2017	11.02.2017	Student
4	Technological process designing of part manufacturing	4	13.02.2017	16.20.2017	Student
5	Calculation of allowances	15	20.02.2017	06.03.2017	Student
6	The size analysis of technological process	12	07.03.2017	18.03.2017	Student
7	Calculation of cutting modes	13	01.04.2017	13.04.2017	Student
8	Technical fixing of technological process laboriousness	8	14.04.2017	21.04.2017	Student
9	Designing part	7	01.05.2017	07.05.2017	Student
10	Results discussion	1	08.05.2017		Student
11	Work conclusion	6	09.05.2017	14.05.2017	Student, supervisor
12	Graph material production	10	27.05.2017	05.06.2017	Student
13	Work revise	19	06.06.2017	24.06.2017	Student, supervisor
14	Defense preparation	1	26.06.2017		Student
15	Defense	1	27.06.2017		Student

From table 2. We formulate the line graph into Gan graph:

№ Stage	Work name	Done by	Time (day)	Month					
				January	February	March	April	May	June
1	Given work plan	Supervisor	2	■					
2	Sources research	Student	7		▨				
3	Definition of manufacturing type	Student	4		▨				
4	Technological process designing of part manufacturing	Student	4		▨				
5	Calculation of allowances	Student	15			▨			
6	The size analysis of technological process	Student	12			▨			
7	Calculation of cutting modes	Student	13				▨		
8	Technical fixing of technological process laboriousness	Student	8				▨		
9	Designing part	Student	7					▨	
10	Results discussion	Student	1					▨	
11	Work conclusion	Student, supervisor	6					▨	
12	Graph material production	Student	10						▨
13	Work revise	Student, supervisor	19						▨
14	Defense preparation	Student, supervisor	2						▨
15	Defense	Student							▨
<b>Total:</b>		Supervisor	29						
		Student	108						

Conventional notation:

■ Supervisor

▨ Student

▩ Student, supervisor

**Technological cost** of a part (a detail) - is the sum of the costs of the implementation process of its manufacturing operations, excluding purchased parts, assemblies. It includes all direct costs associated with the maintenance and operation of process equipment by means of which products are manufactured. Technological cost of is one of the main indicators of technological products.

Technological machining parts annual production of one denomination is given by:

$$A_{\text{miss}} = N (E_m + \sum C_i), \text{ rub.}$$

Where N - annual program of the issue, pcs .

$E_m$  - the expenditure (cost) for basic materials, attributable to the item, rub.;

$C_i$ - technology cost of the  $i$ -th operation for one piece, rub.;

$i = 1 \dots n$  - machining operation according to the technological process of manufacturing parts.

*Table 1*

***Calculation of the guild (technological) cost***

Expenditure	Justification of the expense	Consumption per unit, rub.
1. The cost of basic material	$C_m = W \cdot C_{1kg}$	11.1
2. Basic salary of basic workers	$S_b = \frac{C_j \cdot t_{oc}}{60}$	180.91
3. Additional salary for major job	$S_{ad} = 0,1 \cdot S_b$	18.09
4. Depreciation cost of equipment	$A = \frac{C_{eq} \cdot H_a \cdot t_{oc}}{F_a \cdot 60}$	83.41
5. The costs of current repairs of equipment	$R = \frac{k_r \cdot C_{eq} \cdot t_{oc}}{F_a \cdot 60}$	29.97
6. The cost of power electricity	$P = \frac{W_{eq} \cdot k_m \cdot k_s \cdot C_{1kW} \cdot t_{oc}}{60}$	9.16
7. The cost of production space	$F = \frac{F_{eq} \cdot k_{au} \cdot C_{1m2} \cdot t_{oc}}{F_a \cdot 60}$	38.89
8. The cost of tool wear	$T_w = \frac{(1 + 0,05) \cdot C_i \cdot t_m}{T \cdot 60}$	45.06
9. The cost of the fixture	$F = \frac{C_f \cdot (a + \theta)}{N}$	0,0595
	<b>Total technological cost <math>C_{tech}</math></b>	<b>416.39</b>

1. *The cost of the basic material for detail* is determined by the formula:

$$C_m = H_m \cdot C_{1kg}, \text{ rub.}$$

$H_m$  – the flow rate of the material without deduction of waste, kg;

$C_{1kg}$  – the price of the material, rub/kg.

Table 2

**The cost of materials**

Material name	The price of the material per 1 kg, rub.
Structural steel alloyed by chrome (40X)	37

$$C_m = H_m \cdot C_{1kg} = 0,3 * 37 = 11,1 \text{ rub.}$$

2. *Basic salary of basic workers* is determined by the formula:

$$S_b = \frac{\sum C_j \cdot t_{oc}}{60}$$

$$Z_{\text{ленто}} = \frac{C_{\text{ленто}} \cdot t_{\text{шг}}}{60} = \frac{100 * 1,3 * 11.477}{60} = 24.87 \text{ руб}$$

$$Z_{\text{ток}} = \frac{C_{\text{ток}} \cdot t_{\text{шг}}}{60} = \frac{100 * 2,71 * 27.001}{60} = 121.95 \text{ руб}$$

$$Z_{\text{све}} = \frac{C_{\text{све}} \cdot t_{\text{шг}}}{60} = \frac{100 * 1,3 * 2.27}{60} = 4.9 \text{ руб}$$

$$Z_{\text{внутри-шлиф}} = \frac{C_{\text{внутри-шлиф}} \cdot t_{\text{шг}}}{60} = \frac{100 * 1,83 * 4.12}{60} = 12.57 \text{ руб}$$

$$Z_{\text{кругл-шлиф}} = \frac{C_{\text{кругл-шлиф}} \cdot t_{\text{шг}}}{60} = \frac{100 * 1,83 * 5.451}{60} = 16.62 \text{ руб}$$

Where  $S_b$  – basic wage of workers, rub.;

$C_j$  - the hourly wage rate for the operator of the j-th category, rub/hr;

$t_{oc}$  - operation cycle per part (OCP) for technological operation, min.

Table 3

**Student/Supervisor tariff:**

	Days spent on work	Salary/Month Rub	Months Spent on work	Tariff/Month Rub
Supervisor	29	23000	1.38	31740
Student	108	9000	5.14	46260

**The qualification tariff of the major job**

Qualification rate	3	4	5	6
Tariff the coefficient	1.3	1.83	2.71	4.88

\*Note.

1. Hourly wage rate machinist 1st class at the current time to calculate by the formula:  $C_1 = \frac{MWCT}{22 \cdot 8}$ ,

Where  $MWCT$  – the minimum wage at the current time, rub.; 22 – the number of working days per month; 8 – the duration of the working day, hrs.

2. We have business lot production (or medium-batch production), the degree of execution of work is low, but the production is dominated by the CNC lathes and a milling machine. Take the category of machine operator 5, then the tariff coefficient is 2,71, and we accept the machinist tariff ratio 1.3.

3. **Additional salary of major job** (social insurance) is based on 30% of basic salary:  $S_{ad} = 0.3 \cdot S_b = 0.3 \cdot 180.91 = 54.27$  rub.

4. **The depreciation costs of equipment** are defined by the formula:

$$A = \frac{S_{ct} \cdot H_a \cdot t_{\text{шт}}}{\Phi_d \cdot 60 \cdot 2} = \frac{2450184 \cdot 0,167 \cdot 49.66}{2030 \cdot 60 \cdot 2} = 83.41 \text{ руб}$$

. where  $S_{ct} = 1,1 \cdot S_{nep}$  – the carrying value of the equipment (machine) resulting from the original cost of the equipment and delivery costs (transport costs) and installation in the amount of 10% of  $S_{nep}$ ;

$F_a$  – actual annual Fund operating time of equipment.  $F_a = 2030$  hrs during one shift,

determining the payback period of the equipment useful life  $T_n = \frac{1}{H_a} = 6$ . Uniform

norms of depreciation for metal cutting equipment weighing up to 10 tons of mechanical engineering and Metalworking 0.16.

5. **Costs for the current repair of equipment:**

$$R = \frac{k_r \cdot C_{eq} \cdot t_{oc}}{2 \cdot F_a \cdot 60} = \frac{0.06 \cdot 2450184 \cdot 49.66}{2 \cdot 2030 \cdot 60} = 29.97 \text{ руб.},$$

Where  $k_p = 0,06$  – the ratio of maintenance cost of equipment.

Table 4. The load factor of electric motors in power

Model of the equipment	Cost of machine, rub.	Power, kW	Dimensions, mm (Length × Width)
Lathe, Turning Machine Model 16k20	350000	11	3500 × 1580
Turret, turret lathe	127440	0.45	970 × 410
Milling machine, 8631	1000000	9	2900 × 2080
Center milling machine 8631	1000000	4	4480 × 2200

### 6. The cost of power electricity:

$$P = \frac{W_{eq} \cdot k_m \cdot k_\epsilon \cdot C_{1kW} \cdot t_{oc}}{60}, \text{ rub.}$$

Where  $W_{eq}$  – the motor power of the machine,  $\kappa Bm$ ;

$k_m, k_\epsilon$  – usage of the motor power and time;

$C_{1kW}$  – the price of electricity in an industrial plant at the current time,  $\text{rub}/\kappa W$ .

Table 5. The load factor of motors on time

Metal cutting machines	The load factor of electric motors time $k_\epsilon$		
	Type of production		
	Single and small-scale	Medium	Large-scale and mass
Turning, face, carousel, slotting	0,5	0,6	0,7
Revolving, turret lathe	0,6	0,7	0,8
Grinding	0,4	0,5	0,6
Finishing	0,4	0,5	0,6
Cutting off	0,6	0,7	0,8
Milling	0,6	0,7	0,8
Semi-automatic machines, automatic machines, aggregate	0,7	0,8	0,9

Milling center machine model 8631

$$P = \frac{W_{eq} \cdot k_m \cdot k_\epsilon \cdot C_{1kW} \cdot t_{oc}}{60} = \frac{5.5 \cdot 0.7 \cdot 0.7 \cdot 5.257 \cdot 6.8}{60} = 1.60 \text{ Rub}$$

Turning or lathe machines model 16k20

$$\vartheta = \frac{W_{\text{CT}} \cdot k_M \cdot k_B \cdot \Pi_{1\text{КБТ}} \cdot t_{\text{шт}}}{60} = \frac{11 * 0,7 * 0,4 * 5.257 * 27}{60} = 7.29 \text{pyб}$$

Round (circular) grinding machine 3M153

$$\vartheta = \frac{W_{\text{CT}} \cdot k_M \cdot k_B \cdot \Pi_{1\text{КБТ}} \cdot t_{\text{шт}}}{60} = \frac{4 * 0,5 * 0,6 * 5.257 * 5.45}{60} = 0.57$$

$$\vartheta_{\text{общ}} = \sum \vartheta = 9.46 \text{pyб}.$$

### 7. The costs of production space occupied by equipment:

$$F = \frac{F_{\text{eq}} \cdot k_{\text{au}} \cdot C_{1\text{m}^2} \cdot t_{\text{oc}}}{F_a \cdot 60}, \text{ rub.}$$

Where  $F_{\text{cm}}$  – the area occupied by the equipment (machine),  $\text{m}^2$ ;

$k_{\text{au}}$  – coefficient taking into account additional space for aisles, driveways ( $k_{\text{au}} = 2,5$  for machines with DNC,  $k_{\text{au}} = 3$  – for the rest);

$C_{1\text{m}^2}$  – the rental price of 1  $\text{m}^2$  production area per year at the moment, *rub.*

$C_{1\text{m}^2} = 7257 \text{ rub.}$

Turning lathe - cutting lathe Turning machine model 16K20

$$F = \frac{F_{\text{CT}} \cdot k_{\text{доп}} \cdot \Pi_{1\text{м}} \cdot t_{\text{шт}}}{\Phi_{\text{д}} \cdot 60} = \frac{5,53 * 2,5 * 7527 * 27}{2030 * 60} = 23.07 \text{pyб}$$

Center milling machine 8631

$$F = \frac{F_{\text{CT}} \cdot k_{\text{доп}} \cdot \Pi_{1\text{м}} \cdot t_{\text{шт}}}{\Phi_{\text{д}} \cdot 60} = \frac{1 * 3 * 7527 * 2.27}{2030 * 60} = 0.42 \text{pyб}$$

Round (circular) grinding machine 3M153

$$F = \frac{F_{\text{CT}} \cdot k_{\text{доп}} \cdot \Pi_{1\text{м}} \cdot t_{\text{шт}}}{\Phi_{\text{д}} \cdot 60} = \frac{9.86 * 3 * 7527 * 5.45}{2030 * 60} = 9.96 \text{pyб}$$

$$F_{\text{общ}} = \sum F = 38.89 \text{pyб}$$

### 8. The cost of the wear of the cutting tool:

$$T_w = \frac{(1 + 0,05) \cdot C_t \cdot t_m}{T \cdot 60}$$

Where  $t_m$  – machining time of 1 operation, min.

$C_t$  – cost (price) of the cutting tool, rub.

$T$  – Cutting tool life, min.

- Rough turning cutter

$$N = \frac{(1 + 0,05) \cdot \Pi \cdot t_o}{S_{\text{CT}}} = \frac{1.05 * 280 * 9}{120} = 22.05 \text{pyб}$$

- Face mill

$$N = \frac{(1 + 0,05) \cdot \text{Ц} \cdot t_o}{S_{\text{ср}}} = \frac{1,05 * 180 * 0,22}{120} = 0,35 \text{ руб}$$

- Finish turning cutter

$$N = \frac{(1 + 0,05) \cdot \text{Ц} \cdot t_o}{S_{\text{ср}}} = \frac{1,05 * 220 * 1,51}{120} = 2,91 \text{ руб}$$

- Die cutter

$$N = \frac{(1 + 0,05) \cdot \text{Ц} \cdot t_o}{S_{\text{ср}}} = \frac{1,05 * 230 * 0,06}{120} = 0,12 \text{ руб}$$

- The cutter passing

$$N = \frac{(1 + 0,05) \cdot \text{Ц} \cdot t_o}{S_{\text{ср}}} = \frac{1,05 * 235 * 0,414}{120} = 0,85 \text{ руб}$$

- End mill

$$N = \frac{(1 + 0,05) \cdot \text{Ц} \cdot t_o}{S_{\text{ср}}} = \frac{1,05 * 2500 * 0,35}{120} = 7,66 \text{ руб}$$

$$N_{\text{общ}} = \sum N = 45,06 \text{ руб.}$$

### ***9. The cost of the fixture:***

$$F = \frac{C_f \cdot (a + \epsilon)}{N} = \frac{850 \cdot (0,5 + 0,2)}{10000} = 0,0595 \text{ rub.}$$

Where  $C_f$  is the cost of special fixtures, rub.;

$a = 0,3-0,5$  – the depreciation rate;

$\epsilon = 0,1-0,2$  – the ratio of maintenance cost;

$N$  – The annual program, which developed a device, pcs.

*Table 6*

The cost of special fixtures

Group fixtures	The number of types of parts, pieces.	The cost of fixtures, rub.
1. Small fit (size up to 200×200×200) with a simple case, just to fix the parts (different coasters, simple bars, Cams, etc.)	to 5	to 850
2. Small devices (dimensions up to 300×300×300) with buildings of average complexity (collet mandrel, a simple milling fixture, jigs)	3-5	850-1700
	5-10	1700-3000
	10-15	3000-4500
3. Fixtures with buildings of average complexity (size 400×400×400) with a complex principle of operation (indexing, rotary mechanisms), with simple or medium complexity clamps (gearings)	10-15	3000-3350
	15-20	3350-3600
	20-25	3600-3900
4. Medium fixture with complex cases (2-3 walls), with a complex medium complexity, principle of operation, with pneumatic actuator	20-25	3900-4150
	25-30	4500-6200
	30-35	6200-6400
	35-40	6400-6900
5. The average dimensions of the fixture (500×50×500) with complex cases and challenging principle. Major adaptations (over 500×500×500) simple steps with clips medium difficulty	35-40	6900-7350
	40-45	7350-8100
	45-50	8100-9250
	50-55	9250-10000
6. Large fixture with complex buildings complex principle of action, with complex clamps, pneumatic and hydraulic	50-55	10000-12500
	55-60	12500-14500
	60-65	14500-17500
	65-75	17500-19000
	75-90	19000-21500

**10. Production cost:**

$$C_{pr} = C_{sh} + C_{factory},$$

Where  $C_{sh}$  – shop cost, rub;  $C_{factory}$  – general factory cost, rub.

$$C_{sh} = 1.5 \cdot C_{techn} = 1,5 \cdot 416.39 = 624.39 \text{ rub.}$$

$$C_{\text{factory}} = 1.8 \cdot C_{\text{techn}} = 1,8 \cdot 416.39 = 749.50 \text{ rub.}$$

$$C_{\text{pr}} = C_{\text{sh}} + C_{\text{factory}} = 624.39 + 749.50 = \mathbf{1373.89} \text{ rub.}$$

## ЗАДАНИЕ ДЛЯ РАЗДЕЛА «СОЦИАЛЬНАЯ ОТВЕТСТВЕННОСТЬ»

Студенту:

Группа	ФИО
8ЛЗИ	Таха Мохамед Халед Мохамед

Институт	Неразрушающего контроля	Кафедра	Физических методов и приборов контроля качества
Уровень образования	бакалавр	Направление/специальность	Машиностроение

### Тема дипломной работы: Разработка технологического процесса изготовления детали типа «вала редуктора».

<p><b>Исходные данные к разделу «Социальная ответственность»:</b></p> <p>1. Целью данной работы является создание модели производственного цеха и находящееся в нем оборудование (станки)</p> <p>2. Описание рабочего места на предмет возникновения:</p> <p>1) вредных проявлений факторов производственной среды (для обслуживающего персонала необходимо обеспечить оптимальные, в крайнем случае, допустимые значения метеоусловий на рабочем месте, исключить контакт с вредными, токсичными веществам., которые могут образовываться в процессе работы оборудования, обеспечить комфортную освещенность рабочего места, уменьшить до допустимых пределов шум от станков, вентиляции, обеспечить безопасные значения электромагнитных полей);</p> <p>2) опасных проявлений факторов производственной среды (в связи с присутствием электричества для питания станков и освещенности цеха, наличии горючих (СО) материалов необходимо предусмотреть, если есть, то перечислить средства коллективной и индивидуальной защиты от электро-, пожаро- и взрывоопасности);</p> <p>3) необходимо предусмотреть мероприятия по предотвращению негативного воздействия на окружающую природную среду используемых энергетических проявлений и образующихся отходов: электромагнитные поля от оборудования, парниковые и токсичные газы, стружка, испорченная СОЖ и др.</p> <p>4) необходимо обеспечить устойчивую работу производственного цеха при возникновении чрезвычайных ситуаций, характерных для Сибири – сильные морозы, пурга, человеческий фактор (рассмотреть минимум 2 ЧС – 1 природную, 1 техногенную).</p>
<p><b>Перечень вопросов, подлежащих исследованию, проектированию и разработке:</b></p> <p>1. Анализ выявленных вредных факторов проектируемой производственной среды в следующей последовательности:</p> <p>а) приводится перечень всех используемых в работе вредных веществ, их агрегатное состояние, класс опасности (токсичности), механизм воздействия их на организм человека, единицы измерения количества (концентрации); приводится перечень средств коллективной и индивидуальной защиты персонала, а также защиты окружающей среды;</p> <p>б) приводятся данные по оптимальным и допустимым значениям микроклимата на рабочем месте, перечисляются методы обеспечения этих значений; приводится 1 из расчетов (расчет освещенности на рабочем месте, расчет потребного воздухообмена на рабочем месте, расчет необходимого времени эвакуации рабочего персонала);</p> <p>в) приводятся данные по реальным значениям шума на рабочем месте, разрабатываются или, если уже есть, перечисляются мероприятия по защите персонала от шума, при этом приводятся значения ПДУ, средства коллективной защиты, СИЗ;</p> <p>г) приводятся данные по реальным значениям электромагнитных полей на рабочем месте, в том числе от компьютера или процессора, если они используются, перечисляются СКЗ и СИЗ; приведение допустимых норм с необходимой размерностью (с ссылкой на соответствующий нормативно-технический документ);</p>

<i>предлагаемые средства защиты (сначала коллективной защиты, затем – индивидуальные защитные средства)</i>
<p>2. Анализ выявленных опасных факторов проектируемой производственной среды в следующей последовательности</p> <p>а) приводятся данные по значениям напряжения используемого оборудования, классификация помещения по электробезопасности, допустимые безопасные для человека значения напряжения, тока и заземления (в т.ч. статическое электричество, молниезащита - источники, средства защиты); перечисляются СКЗ и СИЗ;</p> <p>б) приводится классификация пожароопасности помещений, указывается класс пожароопасности помещения, перечисляются средства пожаробнаружения и принцип их работы, средства пожаротушения, принцип работы, назначение (какие пожары можно тушить, какие – нет), маркировка; пожаровзрывобезопасность (причины, профилактические мероприятия).</p>
<p>3. Охрана окружающей среды:</p> <p>организация безотходного производства (приводится перечень отходов при эксплуатации оборудования, перечисляются методы улавливания, переработки, хранения и утилизации образовавшихся на вашем производстве промышленных отходов).</p>
<p>4. Защита в чрезвычайных ситуациях:</p> <p>а) Приводятся возможные для Сибири ЧС; Возможные ЧС: морозы, диверсия. Разрабатываются превентивные меры по предупреждению ЧС;</p> <p>разработка мер по повышению устойчивости объекта к данной ЧС;</p> <p>разработка действий в результате возникшей ЧС и мер по ликвидации её последствий</p>
<p>5. Правовые и организационные вопросы обеспечения безопасности:</p> <p>специальные (характерные для проектируемой рабочей зоны) правовые нормы трудового законодательства (приводится перечень ГОСТов, СНиПов и др. законодательных документов, использованных в своей работе);</p>
<p><b>Перечень графического материала:</b></p> <p>1) Пути эвакуации</p> <p>2) План размещения светильников на потолке рабочего помещения</p>

Дата выдачи задания для раздела по линейному графику	
--	--

**Задание выдал консультант:**

Должность	ФИО	Ученая степень, звание	Подпись	Дата
Ассистент	Невский О.С.			

**Задание принял к исполнению студент:**

Группа	ФИО	Подпись	Дата
8ЛЗИ	Таха Мохамед Халед Мохамед		

## 10. Social Responsibility

This section of the thesis is devoted to the analysis and development of measures to ensure favorable for creative work of an engineer-technologist working conditions.

It addresses issues of industrial safety, ergonomics, fire safety and environmental protection.

### Introduction.

Technological progress has made a major change in the conditions of industrial activity of knowledge workers. Their work has become more intensive, intensive, requiring significant investment of mental, emotional and physical energy. This required a comprehensive solution of problems of ergonomics, hygiene and labor organization, regulation of modes of work and rest.

Nowadays computer technology is widely used in all fields of human activity. When working with the computer the person is exposed to a number of dangerous and harmful production factors: electromagnetic fields (frequency range: 5 Hz to 2 kHz, 2 kHz - 400 kHz), ionizing radiation, noise, static electricity, etc. (SanPiN 2.2.2/2.4.1340-03 Sanitary-epidemiological rules and norms "Hygienic requirements for personal electronic computing machines and the organization of work").

Computer work is characterized by significant mental stress and neuron-emotional stress operators, high tension visual work and a big enough load on the muscles of the hands when working with the keyboard of the computer. Of great importance for the rational design and layout of the workplace, which is important to maintain an optimal working posture of the human operator.

### 9.1 Analysis of dangerous and harmful factors.

The production conditions in the workplace are characterized by the presence of some dangerous and harmful factors (GOST 12.0.002-80 "SSBT. Basic concepts. Terms and definitions"), which are classified by groups of elements: physical, chemical, biological and psychophysiological (GOST 12.0.003-74 "SSBT. Dangerous and harmful factors. Classification").

On working at the computer engineer can have a negative affect following dangerous and harmful production factors:

1. Physical: elevated levels of electromagnetic, x-ray, radiation, the lack of natural

light, inadequate artificial illumination of the working area, increased brightness, increased contrast, a direct and a reflected bestcost, excessive dust, risk of electric shock, noise from equipment operation.

2. Chemical: increased content in the air of working zone of carbon dioxide.

3. Psychophysical: eyestrain and consideration; intellectual, emotional, and prolonged static loads; the monotony of work; a large amount of information processed per unit time; inefficient organization of the workplace.

### 9.1.1 Industrial noise.

The noise worsens the conditions causing a harmful effect on the human body. Working in conditions of prolonged noise exposure experience irritability, headaches, dizziness, memory loss, fatigue, loss of appetite, pain in the ears, etc. Such violations in a number of organs and systems of the human body can cause a negative change in emotional state of a person up to stress. Under the influence of the noise reduced concentration, physiological functions are violated, there is fatigue due to increased energy costs and mental stress, deteriorating speech switching. All this reduces the efficiency and the productivity, quality and safety. Prolonged exposure to intense noise [above 80 dBA] at the hearing of the person leads to its partial or total loss.

The main source of noise in the office are fans of the power supply units of the computer. The noise level ranges from 35 to dB. By SanPiN 2.2.2.542-96 in carrying out the basic work on the computer is the sound level at the workplace should not exceed 50 dBA. To reduce noise walls and ceiling of the room where there is a computers that can be lined with sound absorbing materials.

### 9.1.2 Electromagnetic and ionizing radiation

Most scientists believe that both short and prolonged exposure to all types of radiation from the monitor is not dangerous for the health of the personnel operating the machines. However, comprehensive data on the risk of radiation exposure from the monitors at working with computers does not exist and research in this direction continues.

Valid values for the parameters of non-ionizing electromagnetic radiation from your computer monitor are represented in table. 4.1.

The maximum level of x-ray radiation in the workplace of the operator of the computer usually does not exceed ber/h, and the intensity of ultraviolet and infrared radiation from the screen of the monitor lies within 10...100mBT/m2.

Table 9.1 - Valid values for the parameters of non-ionizing electromagnetic radiation (in accordance with СанПиН 2.2.2/2.4.1340-03)

Parameters name		
Magnetic flux density	in the frequency range 5 Гц - 2 кГц	250 нТл
	in the frequency range 2 кГц - 400 кГц	25 нТл
The electrostatic field		15 кВ/м

To reduce the impact of these types of radiation monitors are recommended for use with low level radiation (MPR-II, TCO-92, TCO-99), install protective screens, and comply with regulated regimes of work and rest.

### 9.1.3 Electric shock.

To dangerous factors may include the presence in the premises of the large amount of equipment that uses single-phase electric current voltage of 220 V and frequency 50 Hz.[4] the danger of electrocution study relates to the premises without increased risk, because there is no humidity, high temperature, conductive dust and the possibility of simultaneous contact with the ground bonding metal objects and metal equipment housings.

During normal operation of the equipment danger electrocution small, however, possible modes, called emergency, when there is a random electrical connection of parts under voltage with grounded structures.

Defeat by an electric current or by an electric arc may occur in the following cases:

- when touching live parts during repair, PC;
- single-phase (single pole) touch non-insulated from the ground of the person to uninsulated live parts of electrical installations under tension;
- when you touch natcoweb parts under voltage, that is, in the case of insulation failure;
- in contact with the floor and walls, trapped under voltage;
- if possible short circuit in the high voltage units: the power unit, the scanner

monitor.

The main measures to ensure electrical safety are:

- isolation (fencing) live parts, eliminating the possibility of accidental contact with them;
- install protective earthing;
- the existence of a common switch;
- timely inspection of technical equipment, insulation.

## 9.2 Ergonomic analysis of the work process.

### 9.2.1 The microclimate.

The parameters of the microclimate can vary within wide limits, while a necessary condition of human life is to maintain constancy of body temperature through thermoregulation, i.e. the body's ability to regulate heat loss to the environment. The principle of normalization of microclimate creation of optimal conditions for heat exchange of human body with the environment.

Computer science is a source of significant heat, which may result in increase of temperature and decrease of relative humidity in the room. In areas where there are computers, should conform to the defined parameters of the microclimate. Sanitary norms SanPiN 2.2.4.548-96, SanPiN 2.2.2/2.4.1340-03 set the values of parameters of microclimate, creating a comfortable environment. These standards are set depending on the time of year, the nature of the labour process and the nature of the workplace (see tab. 4.2).

The volume of the premises occupied by employees of the data center, shall not be less than 19,5 m<sup>3</sup>/person with the maximum number of concurrent wsmenu. Feed rate of the fresh air into the premises, where the computers are given in table. 9.3.

Table 9.2. The parameters of the microclimate in rooms where computers

The period of	The microclimate parameter	Value
Cold	The temperature of the air in the room Relative humidity The speed of air movement	22...24°C 40...60% до 0,1м/с
Warm	The temperature of the air in the room Relative humidity The speed of air movement	23...25°C 40...60% 0,1...0,2м/с

Table 9.3 - Regulations for supplying fresh air to the rooms where the computers are located

Description of room	Volume flow supplied to the premises of fresh air, m <sup>3</sup> /per person per hour
Volume up to 20 m <sup>3</sup> per person	Not less than 30
20...40 m <sup>3</sup> person	Not less than 20

To ensure comfortable conditions are used as organizational methods (rational organization of work, depending on time of day and year, the alternation of work and rest) and technical equipment (ventilation, air conditioning, heating system).

### 9.2.2 Lighting.

Properly designed and implemented industrial lighting improves visual work, reduces fatigue, improves productivity, positively affects the production environment, providing a positive psychological impact on employees, increases safety and reduces injuries.

Insufficient lighting causes eye strain, weakens attention, leads to the onset of premature fatigue. Overly bright lighting causes glare, irritation and pain in the eyes. Wrong direction of light in the workplace can create harsh shadows, glare, confusion working. All these reasons can lead to an accident or occupational

diseases, hence the importance of a correct calculation of illumination.

There are three types of lighting - natural, artificial and combined (natural and artificial) .

Natural lighting - lighting daylight penetrating through the light apertures in the outer walling of the premises. Natural light is characterized in that it varies widely depending on time of day, time of year, the nature of the field and a number of other factors.

Artificial lighting is used when working in the dark and during the day when you are unable to provide normalized values of the coefficient of natural light (cloudy weather, short daylight hours). Lighting, which is insufficient according to the norms of natural light supplemented with artificial, is called a combined lighting.

Artificial lighting is divided into operating, emergency, evacuation, security. Illumination, in turn, can be shared or combined. Total - lighting in which the lamps are placed in the upper zone of the room evenly or in relation to the location of the equipment. Combo - lighting, which is added to the total local lighting.

According to SP 52.13330.2011 "Natural and artificial lighting. Actualized edition of SNiP 23-05-95" in the premises of the data center you want to apply a combined lighting system.

When carrying high visual accuracy (the smallest size of an object distinguish between 0,3...0,5 mm) the coefficient of natural lighting (KEO) should not be below 1.5% when visual work average precision (smallest size of an object distinguish between 0,5...1,0 mm) KEO should not be below 1.0%. As sources of artificial light typically used fluorescent lamps type LB or DRL, which are combined in pairs in the lamps, which must be placed above the working surfaces evenly .

Requirements for lighting in rooms with computers, the following: when you run the visual works of high precision General illumination shall be LC, and combined - LC; similar requirements when performing work average precision - 200 and LC respectively.

In addition the entire field of view must be lit evenly is a basic hygiene requirement. In other words, the degree of illumination of the room and the brightness of the computer screen should be approximately equal, because the bright light in the area of peripheral vision significantly increases eye strain and,

consequently, leads to fatigue.

#### 4.2.3 Ergonomic requirements to the workplace

Design of workplaces, equipped with terminals, is among the important problems of ergonomic design in computer science.

Working place and relative location of all of its elements must correspond to the anthropometric, physical and psychological requirements. Of great importance is also the nature of the work. In particular, when workplace design engineer must meet the following basic conditions: optimal placement of equipment that is part of the workplace and sufficient working space that allows you to perform all the necessary movements and displacement.

Ergonomic aspects of design Video Terminal jobs, in particular, are: the height of the working surface, the size of legroom, location requirements documents in the workplace (availability and sizes stand for documents, varying placement, the distance from the user's eyes to screen, document, keyboard, etc.), characteristics of the work chair, the requirements to the table surface, the adjustability of the elements of the workplace.

The main elements of the workplace and engineering are the Desk and chair. The main working position is the sitting position.

Working sitting posture causes minimal fatigue engineer. The rational layout of the workplace provides a clear procedure and the permanence of the placement of objects, tools and documentation. What is required to perform work more often located in the zone of easy reach of the workspace.

Motor field - space of the workplace, which can be a physical action of a person.

The maximum range of the hands is a part of the motor field workplace, limited arcs described by the maximally outstretched arms during their movement in the shoulder joint.

The optimal zone is a part of the motor field workplace, limited arcs described by the forearm when moving the elbow with support at the point of the elbow

and with relatively immobile shoulder.

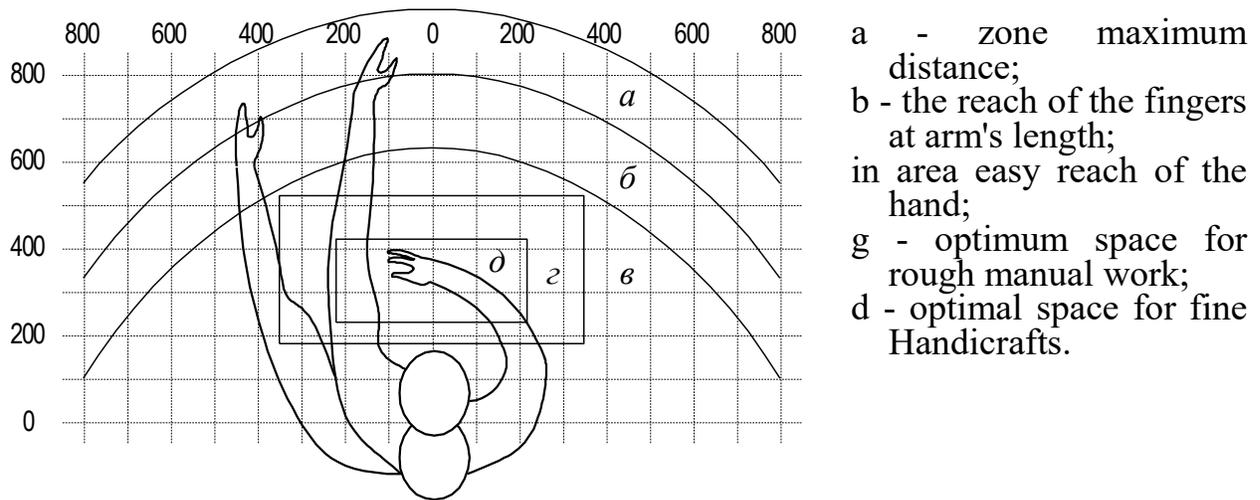

Fig. 1. Zones of arm in horizontal surface

*Optimal placement of items of work and documentation in the areas of distance:*

The DISPLAY is located in zone a(center);

The SYSTEM UNIT is provided in the recess of the table;

KEYBOARD - in zone g/d;

"MOUSE" - in the area sprawa;

The SCANNER in the zone a/b (left);

The PRINTER is in zone a (right);

DOCUMENTATION: required when working in the area easy reach palms, and in the drawers of table - literature, constantly unused.

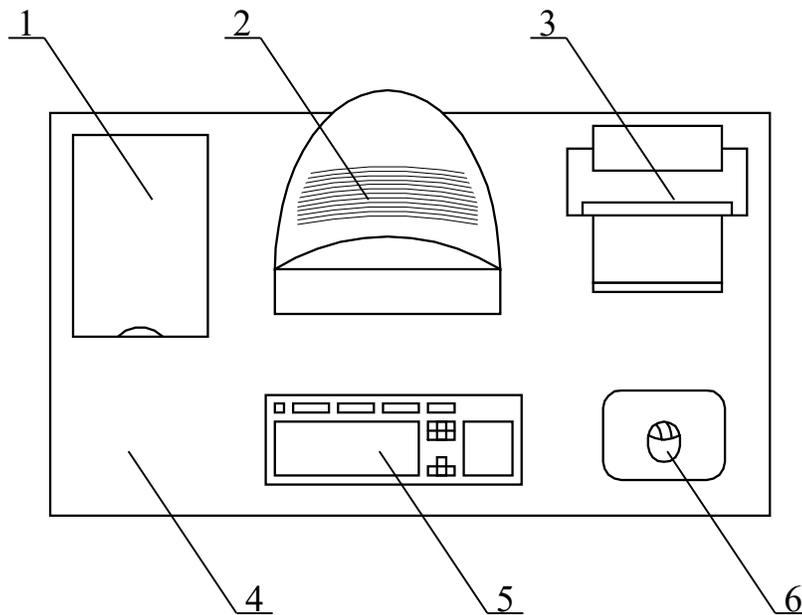

Fig. 2. Personal computer's components

In Fig. 2 shows an example of placement of the main and peripheral components of a PC on the desktop programmer.

1 scanner, 2 – monitor, 3 – printer 4 – the surface of the desktop,  
5 – keyboard 6 – manipulator of type "mouse".

For comfortable work Desk should satisfy the following conditions:

- the height of the table should be selected based on the ability to sit freely in a comfortable pose, if necessary, based on the armrests;
- the lower part of the table needs to be designed to be able to sit comfortably, was not forced to draw in the legs;
- the surface of the table must have the following properties, eliminates glare in the field of view of the programmer;
- the design of the table should have drawers (at least 3 for documentation, listings, stationery).
- the height of the work surface is recommended in the range of 680-760mm. The height of the surface, onto which the keyboard should be about 650mm.

Great importance is attached to the characteristics of the Desk chair. So, recommended seat height above floor level is in the range of 420-550mm. The seat surface is soft, the front edge rounded, and the back angle is adjustable.

It is necessary to include in the design the possibility of posting documents: at

the side of the terminal, between the monitor and keyboard, etc. in addition, in cases where the video display is of low quality images, such as visible flicker, the distance from the eye to the screen make more (about 700 mm) than the distance from the eye to the document (300-450mm). Generally with a high quality image on the video display the distance from your eyes to screen, document and keyboard to be equal.

The screen position is determined by:

- reading distance of (0,6...0,7 m);
- angle reading, the viewing direction 20° below the horizontal toward the center of the screen, and the screen perpendicular to this direction.

Must also be capable of regulating the screen:

- height +3 cm;
- tilt from -10° to +20° relative to the vertical;
- in left and right directions.

Of great importance for the correct working posture of the user. When an uncomfortable working position may have pain in the muscles, joints and tendons. The requirements for the operating posture of the user video terminal the following:

- the head should not be tilted more than 20°,
- shoulders should be relaxed,
- elbows - angle of 80°...100°,- forearms and hands in a horizontal position.

The reason for poor posture of users due to the following factors: there is a good stand for documents, the keyboard is too high, and documents - low, no place to put hands and arms, not enough legroom.

In order to overcome these drawbacks provide General advice: better mobile keyboard; must be provided with special devices for adjusting the height of the Desk, keyboard and screen and the palm rest.

Essential for productive and quality work at the computer to have the dimensions

of the labels, the density of their placement, contrast ratio and brightness of the characters and background screen. If the distance from the eye of the operator to the display screen is 60...80 cm, the height of the sign shall be not less than 3mm, the optimal ratio of the width and height of the sign is 3:4, and the distance between the marks – 15...20% of their height. The ratio of the brightness of the screen background and characters - from 1:2 to 1:15.

While using the computer, the physicians are advised to install the monitor at a distance of 50-60 cm from the eye. Experts also believe that the upper part of the video display should be at eye level or slightly below. When a person looks straight ahead, his eyes opened wider than when he looks down. Due to this, the area is significantly increased, causing dehydration of the eyes. Besides, if the screen is mounted high and eyes wide open, disturbed function of blinking. This means that the eye does not close completely, not washed by the lacrimal fluid, do not receive sufficient moisture, leading to fatigue.

The creation of favourable working conditions and the right aesthetic design jobs in manufacturing is of great importance both to facilitate and to enhance its attractiveness, positive impact on productivity.

#### 4.3. Development of measures of protection from dangerous and harmful factors

As measures to reduce noise it is possible to propose the following:

1. Veneer ceiling and walls with sound-absorbing material (reduces noise by 6-8 dB);
2. Shielding the workplace (raising of walls, diaphragms);
3. Installation in computer rooms equipment, producing minimal noise;
4. The rational layout of the room.

Protection from noise should be performed in accordance with GOST 12.1.003-83 "Noise. General safety requirements, and sound insulation of enclosures shall meet the requirements of Chapter SNiP 23-03-2003 "Protection against noise. Design standards".

When protection against external radiation arising from work with display, take the following actions:

According to SanPiN 2.2.2/2.4.1340-03 for optimal health and maintaining health during the work shift must be installed regulated breaks – when 8-hour day duration 15 minutes every hour;

1. The display is set so that from the screen to the operator not less than 60-70 cm;
2. Must be used in displays with built-in protective screens.

Electrical safety technical ways and means:

Since all live parts of the computer are isolated, accidental contact with live parts is excluded.

To provide protection from electric shock when touching metal nateweb parts that may be under stress as a result of damage to the insulation, it is recommended to use protective grounding.

Chassis ground of the computer is provided by summing the grounding conductor to the supply outlets. The grounding resistance of  $4 \Omega$ , according to (PUE) for electrical installations with voltage up to 1000 V.

Organizational measures to ensure electrical safety:

The main organizational activity is instruction and training in safe methods of work, as well as a test of knowledge of safety rules and instructions in accordance with the position in relation to the work performed.

When performing unscheduled and scheduled maintenance of computing the following steps:

- Remove computer from network
- Voltage testing

After performing these steps, the repair of faulty equipment.

If the repair is carried out on live parts under voltage, execution of work is carried out by at least two individuals with means of electrical safety.

#### 9.4.1 Fire safety

The fire in the study, can lead to very adverse consequences (loss of valuable information, property damage, loss of life, etc.), it is therefore necessary to identify and eliminate all causes of fire; to develop a plan of measures for the elimination of fire in the building; the plan of evacuation of people from buildings.

The causes of fire can be:

- malfunction wiring, sockets and switches which may cause a short circuit or breakdown of insulation;
- damaged (defective) electrical appliances;
- use indoor electric heaters with open heating elements;
- the occurrence of a fire due to a lightning strike to the building;
- fire building due to external influences;
- careless handling of fire or non-observance of fire safety.

#### 9.4.2 Prevention of fire

Fire prevention is a complex of organizational and technical measures aimed at ensuring the safety of people on the prevention of fire, limiting its distribution and also creation of conditions for successful fire extinguishing. For the prevention of fire is extremely important proper fire risk assessment of buildings, identification of hazards and justification of the ways and means of parareptilia and protection.

In modern computers a very high density of elements of electronic circuits.

In close proximity to each other are arranged to the connecting cord, patch cords. When flowing over them

electric current is allocated a significant amount of heat, which may result in raising the temperature to 80-100°C, it is possible to melt the insulation of the connecting wires, their exposure, and, as a result, a short circuit.

For removal of excess heat from computers serve as ventilation and air

conditioning. However, they can be an additional fire hazard to the building if the fire spread.

The premise computing laboratory for explosion safety concerns to the category (in accordance with the Federal law from July, 22nd, 2008 N 123-FZ "Technical regulations on fire safety requirements").

One of the conditions of fire safety - the elimination of possible ignition sources.

In the office of the ignition sources can be:

- faulty electrical faults in wiring, electrical outlets and switches. To eliminate the risk of fire for these reasons, it is necessary to identify and eliminate defects, carry out routine inspection and eliminate all faults;

- faulty electrical appliances. Necessary measures to prevent fire include the timely repair of electrical appliances, high-quality correction of damage that do not use faulty electrical appliances;

- space heating electric heaters with open heating elements. Open heating surface can cause a fire, as in the room are paper documents and reference materials in the form of books, manuals, and paper – flammable object. In order to prevent fire, do not use outdoor heaters indoors;

- short circuit in the wiring. In order to reduce the probability of fire due to short circuit it is necessary that the wiring was hidden.

- getting into the building from lightning. In the summer during a thunderstorm, possibly a lightning strike resulting in possible fire. To avoid this, it is recommended to install on the roof of the lightning arrester;

- non-observance of measures of fire safety and Smoking indoors can also lead to fire. To eliminate the ignition as a result of Smoking indoors is recommended to strictly forbid Smoking, and allow only in strictly designated place.

In order to prevent fire hold with engineers working in the room, fire drill, which is to familiarize employees with fire safety rules, and to teach the use of primary fire extinguishing means.

In the event of a fire you must first disconnect the power, to call the fire Department, evacuate people from the premises in accordance with the

evacuation plan and proceed to extinguish the fire with fire extinguishers. If there is a small hearth fire, you can use the means at hand for the purpose of preventing access of air to the object of fire.

In the laboratory are the primary means of fire suppression, a box of dry sand, water, asbestos blankets, manual powder extinguisher OP - 4. To prevent fire and fire prevention systematically conducted inspection of electrical circuits and equipment are detected early and eliminated the fault. The laboratory has developed an evacuation plan, which made available to the laboratory staff.

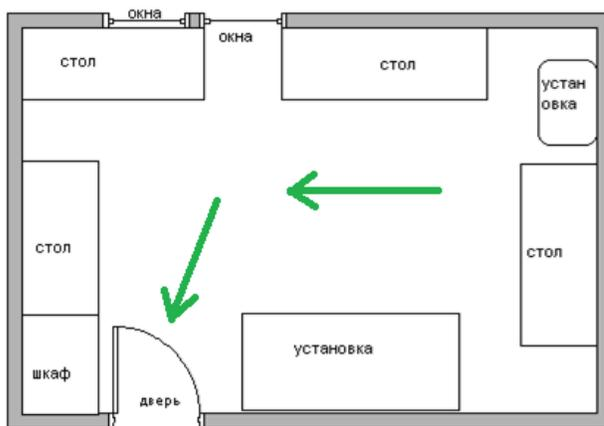

Fig. 3. The evacuation plan

## 9.5 Environmental Protection

Environmental protection is really important and meaningful process. That is why these issues are devoting a lot of time and attention. Environment is the complex of measures aimed at preventing the negative impact of human activity on nature, providing a favorable and safe conditions of human life.

Creation of conditions for improvement of ecological conditions - the process is long, requires coherence and consistency of action. Priority in the environmental policy of the Russian Federation today the following questions:

- ensuring environmentally safe living conditions;
- rational use and protection of natural resources;

- ensuring environmental and radiation safety (MPE);
- the greening of industry;
- increase of ecological culture of society and the formation of ecological consciousness in humans.

Important role in the protection of the environment is given to the procedures for the rational placement of the sources of contaminants. These include:

- 1) making industrial enterprises of major cities and new construction in sparsely populated areas with unsuitable and unsuitable for agricultural use of land;
- 2) the optimum location of industrial enterprises taking into account the topography of the terrain and the wind rose;
- 3) establishment of sanitary protection zones around industrial plants.
- 4) the rational layout of the urban area, providing optimal environmental conditions for humans and plants.

In the environment play an important role in the quality of the environment designed to conduct systematic monitoring of the condition of the atmosphere, water and soil for the actual levels of pollution. The information obtained about the dirt allows you to quickly identify the causes of increasing concentrations of harmful substances in the environment and actively to fix them.

Environmental protection is a complex problem that requires the efforts of scientists of many specialties. Of particular importance is the quantitative assessment of the impact of environmental pollution and, above all, damage to the national economy of pollution. Protecting the environment from contamination at the present stage in addition to economic objectives: increasing social productivity - and also includes socio-economic task of improving the conditions of human life, the preservation of his health.

To minimize the level of pollution emitted by the enterprises, it is necessary to make the following mandatory measures for the environmental protection (EP). Measures for environmental protection are:

1. The identification, assessment, permanent control and limitation of harmful emissions into the environment, creating environmental and resource-saving

technologies and equipment.

2. The development of legal laws, legal acts on protection of the natural environment, as well as material incentives for compliance with these laws and environmental measures.

3. The prevention of environmental degradation and the environment from harmful and hazardous factors through the creation of dedicated areas (SPZ).

Non-waste technology is the most active form of protection of the environment from the harmful effects of industrial emissions. Under the concept of "soft technology" is understood as the set of activities in production processes from raw materials to ready-made products, thereby reducing to a minimum the amount of harmful emissions and reduces the impact of waste on the environment to an acceptable level. In this set of activities includes:

1) creation and implementation of new processes for products with the formation of the least amount of waste;

2) development of various types of closed technological systems and water cycles on the basis of methods of wastewater treatment;

3) development of systems for recycling of production waste into secondary materials;

4) creation of territorial-industrial complexes having a loop structure material flows of raw materials and waste inside the complex.

Until full implementation of non-waste technology important areas of greening of industrial production should be considered:

1) improvement of technological processes and development of new equipment with lower emissions of pollutants and waste into the environment;

2) the replacement of toxic waste on non-toxic;

3) replacement of non-recyclable waste recyclable;

4) the use of passive methods of environmental protection.

Passive methods of protection of the environment includes a complex of

measures to limit emissions from industrial production and subsequent recovery or disposal of waste. These include:

- treatment of wastewater from impurities;
- treatment of gaseous emissions of harmful impurities;
- the dispersion of harmful emissions into the atmosphere;
- suppress noise in its distribution;
- measures to reduce levels of infrasound, ultrasound and vibration in their ways of spreading;

shielding energy sources of environmental pollution.

Enterprises, individual buildings and facilities production processes that are sources of negative impact on the environment and human health, should be separated from residential buildings sanitary-protective zones.

Sanitary protection zone (SPZ) separates the territory of the industrial area from residential buildings, the landscape and recreational areas, recreation areas, resort to compulsory designation of boundaries of the special information signs

Install the following sizes of sanitary protection zones:

- the enterprise of the fourth class - 100 m (Machine-building enterprise with Metalworking, painting without casting.).

## 11. Literature

1. Справочник технолога-машиностроителя. В 2-х т. Т. 2 /Под ред. А.Г. Косиловой и Р.К. Мещерякова.— 4-е изд., перераб. и доп.— М.: Машиностроение, 1985. 496 с.
2. Мягков В.Д., Палей М.А., Романов А.Б., Брагинский В.А. Допуски и посадки. Справочник. В 2-х ч. Том 2. – Л.: Машиностроение, 1983. – 448 с.
3. . Скворцов В.Ф. Основы размерного анализа технологических процессов изготовления деталей: Учебное пособие. – Томск: Изд. ТПУ, 2006. – 100 с.
4. Горбацевич А.Ф., Шкред В.А. Курсовое проектирование по технологии машиностроения. – М.: ООО ИД «Альянс», 2007. – 256 с.
5. Прогрессивные режущие инструменты и режимы резания металлов: Справочник / Баранчиков В.И., Жаринов А.В., Юдина Н.Д., Садыхов А.И. и др.; Под общ. ред. В.И. Баранчикова. – М.: Машиностроение, 1990.
6. Анурьев В.И. Справочник конструктора машиностроителя: В 3 т. Т. 1. – М.: Машиностроение, 2001. – 920 с.: ил.
7. Справочник инструментальщика /И.А. Ординарцев, Г.В. Филипов, А.Н. Шевченко и др., Под общей редакцией И.А.Ординарцева.-Л.: Машиностроение. Ленингр. Отделение .1987.-846 с.
8. Diploma Thesis. Methodical instructions / V. N. Kozlov; Tomsk Polytechnic University (TPU). — Tomsk: Tomsk Polytechnic University Publishing House, 2015
9. Material cutting and cutting tools: study aid / S. V. Kirsanov (<http://www.lib.tpu.ru/fulltext2/m/2014/m261.pdf>)
10. Technology of Mechanical Engineering, part 1: study aid / V. N. Kozlov; Tomsk Polytechnic University (TPU). — Tomsk: Tomsk Polytechnic University Publishing House, 2002.
11. Technology of Mechanical Engineering, part 2: study aid / V. N. Kozlov; Tomsk Polytechnic University (TPU). — Tomsk: Tomsk Polytechnic University Publishing House, 2003.