



California State University, San Bernardino
CSUSB ScholarWorks

Electronic Theses, Projects, and Dissertations

Office of Graduate Studies

12-2017

CONSTRUCTION OF FINITE GROUP

Michelle SoYeong Yeo

California State - San Bernardino, michelleyeo61@gmail.com

Follow this and additional works at: <https://scholarworks.lib.csusb.edu/etd>



Part of the [Mathematics Commons](#)

Recommended Citation

Yeo, Michelle SoYeong, "CONSTRUCTION OF FINITE GROUP" (2017). *Electronic Theses, Projects, and Dissertations*. 592.

<https://scholarworks.lib.csusb.edu/etd/592>

This Thesis is brought to you for free and open access by the Office of Graduate Studies at CSUSB ScholarWorks. It has been accepted for inclusion in Electronic Theses, Projects, and Dissertations by an authorized administrator of CSUSB ScholarWorks. For more information, please contact scholarworks@csusb.edu.

CONSTRUCTION OF FINITE GROUP

A Thesis

Presented to the

Faculty of

California State University,

San Bernardino

In Partial Fulfillment

of the Requirements for the Degree

Master of Arts

in

Mathematics

by

Michelle SoYeong Yeo

December 2017

CONSTRUCTION OF FINITE GROUP

A Thesis

Presented to the

Faculty of

California State University,

San Bernardino

by

Michelle SoYeong Yeo

December 2017

Approved by:

Dr. Zahid Hasan , Committee Chair

Date

Dr. Joseph Chavez , Committee Member

Dr. Wenxiang Wang , Committee Member

Dr. Charles Stanton, Chair,
Department of Mathematics

Dr. Corey Dunn
Graduate Coordinator,
Department of Mathematics

ABSTRACT

The main goal of this project is to present my investigation of finite images of the progenitor $2^{*n} : N$ for various N and several values of n . We construct each image by using the technique of double coset enumeration and give a proof of the isomorphism type of the image. We obtain the group $7^2 : D_6$ as a homomorphic image of the progenitor $2^{*14} : D_{14}$, we obtain the group $2^4 : (5 : 4)$ as a homomorphic image of the progenitor $2^{*5} : (5 : 4)$, we obtain the group $(10 \times 10) : ((3 \times 4) : 2)$ as a homomorphic image of the progenitor $2^{*15} : (15 \times 4)$, we obtain the group $PGL(2, 7)$ as a homomorphic image of the progenitor $2^{*7} : D_{14}$, we obtain the group S_6 as a homomorphic image of the progenitor $2^{*5} : (5 : 4)$, and we obtain the group S_7 as a homomorphic image of the progenitor $2^{*15} : (15 : 4)$. Also, have given some unsuccessful progenitors.

ACKNOWLEDGEMENTS

First of all, I would like to thank Dr. Zahid Hasan who is my advisor for this project. I am thankful for your guidance. You led me down the right path with your immense source of patience and motivation.

I would also like to thank Dr. Joseph Chavez and Dr. Wenxiang Wang for having such influential roles in the thesis committee and for encouraging me to finish this project. I must also extend my gratitude to Dr. Corey Dunn and Dr. Charles Stanton for guiding me through my academic career as I pursued my graduate degree.

Finally, I cannot thank my family enough for their amazing support. My academic achievements would not have been obtained without my husband and daughter, Jacob and Cherrie.

Table of Contents

Abstract	iii
Acknowledgements	iv
List of Figures	vii
Introduction	1
1 Preliminaries	2
1.1 Group Theory Preliminaries	2
1.2 Group Extension Preliminaries	8
1.3 Theorems	9
1.4 Lemmas	11
1.5 Preliminary for Monomial Presentations	12
2 Construction of $7^2 : D_6$	13
2.1 Double Coset Enumeration of $7^2 : D_6$	13
2.2 Proof of $G \cong 7^2 : D_6$	17
2.3 Magma Work for $7^2 : D_6$	20
3 Construction of $2^4 : (5 : 4)$	39
3.1 Double Coset of Enumeration of $2^4 : (5 : 4)$	39
3.2 Proof of $G \cong 2^4 : (5 : 4)$	42
3.3 Magma Work for $2^{*5} : (5 : 4)$	46
4 Construction of $(10 \times 10) : ((3 \times 4) : 2)$	50
4.1 Double Coset Enumeration of $(10 \times 10) : ((3 \times 4) : 2)$	50
4.2 Proof of $G \cong (10 \times 10) : ((3 \times 4) : 2)$	54
5 Construction of $PGL(2, 7)$	60
5.1 Double Coset Enumeration of $PGL(2, 7)$	60

6	Construction of S_6	68
6.1	Double Coset Enumeration of S_6	68
6.2	Proof of $G \cong S_6$	71
6.3	Magma Work for S_6	72
7	Construction of S_7 over $(15 : 4)$	81
7.1	Double Coset Enumeration of S_7 over $(15 : 4)$	81
7.2	Proof of $G \cong S_7$	86
8	Unsuccessful Progenitors	87
	Appendix A Magma Work for $2^4 : (5 : 4)$	95
	Appendix B Magma Work for S_7	101
	Appendix C Magma Work for $(10 \times 10) : ((3 \times 4) : 2)$	223
	Appendix D Magma Work for $Sym(15)$	255
	Appendix E Magma Work for S_6	261
	Bibliography	269

List of Figures

2.1	Cayley diagram of $7^2 : D_6$ over D_{14}	17
3.1	Cayley diagram of $2^4 : (5 : 4)$ over $(5:4)$	42
4.1	Cayley diagram of $(10 \times 10) : ((3 \times 4) : 2)$ over $(15 : 4)$	54
5.1	Cayley diagram of $PGL(2, 7)$ over D_{14}	67
6.1	Cayley diagram of S_6 over $(5 : 4)$	71
7.1	Cayley diagram of S_7 over $(15:4)$	86

Introduction

A progenitor is an infinite semi-direct product of the form $m^{*n} : N$, where $N \leq S_n$ and $m^{*n} : N$ is a free product of n copies of a cyclic group of order m . It is known that a progenitor of this type gives some very important finite groups, including simple group as homomorphic images.

The main goal of this is present my investigation of finite images of the progenitor $2^{*n} : N$ for various N and several values of n .

We construct each image by using the technique of double coset enumeration and give a proof of the isomorphism type of the image in chapter 2, we obtain the group $7^2 : D_6$ as a homomorphic image of the progenitor $2^{*14} : D_{14}$, in chapter 3, we obtain the group $2^4 : (5 : 4)$ as a homomorphic image of the progenitor $2^{*5} : (5 : 4)$, in chapter 4, we obtain the group $(10 \times 10) : ((3 \times 4) : 2)$ as a homomorphic image of the progenitor $2^{*15} : (15 \times 4)$, in chapter 5, we obtain the group $PGL(2, 7)$ as a homomorphic image of the progenitor $2^{*7} : D_{14}$, in chapter 6, we obtain the group S_6 as a homomorphic image of the progenitor $2^{*5} : (5 : 4)$, and in chapter 7, we obtain the group S_7 as a homomorphic image of the progenitor $2^{*15} : (15 : 4)$.

Also, we list some unsuccessful progenitors in chapter 8.

Chapter 1

Preliminaries

1.1 Group Theory Preliminaries

Definition 1.1. If X is a nonempty set, a **permutation** of X is a bijection

$$\phi : X \rightarrow X.$$

The set of all permutation of X is a symmetric group. It is denoted by S_x .

Definition 1.2. A permutation is said to be **transposition** if it changes two elements and fixes the rest.

Definition 1.3. S_n is a **symmetric group** that composed by all bijective mapping

$$\phi : X \rightarrow X, \text{ where } X \text{ is a nonempty set.}$$

Definition 1.4. The **alternating group** A_n is a subgroup of S_n with order equal to $\frac{n!}{2}$.

Definition 1.5. A group G is **abelian** if every pair $a, b \in G$ commutes such as $a * b = b * a$

Definition 1.6. (order of permutation) Let $\alpha = (x_1, \dots, x_i)(x_1, \dots, x_j) \in S_x$, where α is a multiple of two disjoint cycle. The order of α is the least common multiple of the i -cycle and the j -cycle.

$$|\alpha| = \text{lcm}(i, j).$$

Definition 1.7. Let G and H be groups. A map $\phi : G \rightarrow H$ is called **homomorphism** if

$$\alpha, \beta \in G, \phi(\alpha\beta) = \phi(\alpha)\phi(\beta).$$

Definition 1.8. If a homomorphism ϕ from G onto H is a bijection, ϕ is an **isomorphism**. G is isomorphic to H ($G \cong H$).

Definition 1.9. A nonempty subset H of a group G is a **subgroup** of G if

$$h \in H \text{ implies } h^{-1} \in H, \text{ and } h, k \in H \text{ implies } hk \in H. \quad H \leq G.$$

Definition 1.10. If H is any subgroup other than G , H is a **proper subgroup** of G .

Definition 1.11. If H is the subgroup generated by the identity of group G , H is a **trivial subgroup** of G .

Definition 1.12. If G is a group and $a \in G$, then the **Cyclic subgroup generated by a** is the set of all powers of a and it is denoted by $\langle a \rangle$.

Definition 1.13. Let G be a group and $K \leq G$. K is a **maximal subgroup** of G if there is no normal subgroup $N \leq G$ such that $K < N < G$.

Definition 1.14. If $g \in G$ and $\phi \in S_X$, then ϕ **fixes** g if $\phi(x) = g$, ϕ **moves** g if $\phi(x) \neq g$.

Definition 1.15. If $\alpha, \beta \in S_n$, α and β are **disjoint** if every element moved by one permutation is fixed by the other. if

$$\alpha(n) \neq n, \text{ then } \beta(m) = m \text{ and if } \alpha(x) = x, \text{ then } \beta(x) \neq x.$$

Definition 1.16. If a permutation interchanges a pair of elements, it is called a **transposition**.

Definition 1.17. Let G be a group and $x \in G$, the number of elements in group is the **order of x** and it is denoted by $|\langle x \rangle|$.

Definition 1.18. Let H be a nonempty subset of a group G . Let $w \in G$ where $w = h_1^{e_1} h_2^{e_2} \dots h_n^{e_n}$, with $h_i \in H$ and $e_i = \pm 1$. We say that w is a **word** on H .

Definition 1.19. Let H be a group. We say H is a **direct product** of two subgroups G and K if:

- $G \trianglelefteq H, K \trianglelefteq H;$
- $H = GK;$
- $G \cap K = 1,$

Definition 1.20. If $H \leq G$ and $x \in G$, the subset of G , $Hx = \{xh : x \in H\}$ is the **right coset** of H in G .

Definition 1.21. If $H \leq G$ and $x \in G$, $HxH = \{HxH|x \in H\}$ is the **double coset** of G .

Definition 1.22. If $h^n = 1$ for all $h \in G$, the group G has an **exponent** n .

Definition 1.23. A subgroup $X \leq G$ is **normal** in G and it is denoted by $X \trianglelefteq G$.

Definition 1.24. Let $x \in G$, the for $x^{-1}gx$ for $x \in G$ is the **conjugate** of g in G

Definition 1.25. If $X \triangleleft G$, the coset X in G form a group G/X of the order $[G : X]$ is called the **quotient group**.

Definition 1.26. If $x, y \in G$, the **commutator** of x and y , $[x, y]$ is $[x, y] = xyx^{-1}y^{-1}$.

Definition 1.27. The \dot{G} is called **derived subgroup**. It is the subgroup of G generated by all commutators.

Definition 1.28. Let G is the group, $G \neq 1$. The group G is **simple** if it does not have normal subgroups other than G and 1 .

Definition 1.29. A group H is a **p-group** if the order of every element of H is a power of p .

Definition 1.30. Let H be a finite group. If it is an abelian, it is called **elementary abelian group** and every nontrivial element $x \in H$ has a prime order p .

Definition 1.31. We call X^g **stabiliser**. $X^g = \{x \in X | g^x = g\}$, where x is a word of t_i 's.

Definition 1.32. $X^{(g)} = \{x \in X | Xg^x\}$ where g is a word of t_i 's. We call $X^{(g)}$ a *coset stabiliser*.

Definition 1.33. If X is a set and G be a group. We say X is a **G-set** if there exists a function $\phi : G \times X \rightarrow X$ and the following hold for $\phi : (g, x) \rightarrow gx$.

- $1x = x$, for all $x \in X$.
- $g(hx) = (gh)x$, for $g, h \in G$ and $x \in X$.

Definition 1.34. Let G be a group. The **center** of G , $Z(G)$, is the set of all elements in G that commute with all elements of G .

Definition 1.35. Let H be a subgroup of G . Then the subgroup K , ($K \leq G$) is a **complement** of H in G if

- $HQ = G$
- $H \cap Q = 1$

Definition 1.36. A group X is a **semi-direct product** of K by Q . $X = K : Q$ if $K \triangleleft X$ and K has a complement $Q_1 \cong Q$.

Definition 1.37. For the group G , $(Z(G))$ is a **center** of G . The set of all $g \in G$ commute with every elements of G .

Definition 1.38. Let G be a group. $C_G(g)$ is a **centralizer** of G . It is set of all $x \in G$ commute with g .

$$C_G(g) = \{g^x = g | x \in G\}$$

Definition 1.39. Let K and G be groups. $N_G(K)$ is a **normalizer** denoted by

$$N_G(K) = \{g \in G | gKg^{-1} = K\} \text{ when } K \leq G.$$

Definition 1.40. Let G be a group and $a \in G$, we call a^G **conjugacy class** when

$$a^G = \{a^g | g \in G\} = \{g^{-1}ag | g \in G\}.$$

Definition 1.41. If $x \in X$, $g \in G$, the set X^G is the **G-Orbit** when

$$X^G = \{x^g | g \in G\}.$$

Definition 1.42. For a G -set X with an action α , we call the following process **faithful**.

$$\bar{\alpha} : G \rightarrow S_x \text{ is injective.}$$

Definition 1.43. Let H be a G -set of degree n and let $k \leq n$ be a positive integer, then H is **K -transitive** if there are $g \in G$ with $gh_i = x_i$ for $i = 1, \dots, k$.

Definition 1.44. A k -transitive G -set is **sharply k -transitive** if the identity fixes the distinctive elements of X , k , only.

Definition 1.45. We call D_{2n} **Dihedral Group**. Dihedral group generated by two elements x and y with presentation $\langle x, y | x^n = y^2 = (xy)^2 = 1 \rangle$. The order of D_{2n} is equal to $2n$ and $2n \geq 4$.

Definition 1.46. The **Quaternion Group** Q is a group generated by two elements x and y with the presentation

$$\langle x, y | x^{2n} = y^4 = 1, x^n = y^2, y^{-1}xy = x^{-1} \rangle.$$

Definition 1.47. The **Normal Series** is a chain of subgroups,

$$G = G_0 = G \supseteq G_1 \supseteq \dots \supseteq G_n = 1 \in G_i \triangleleft G, \forall 1 \leq i \leq n.$$

Definition 1.48. Let G be a group. The **Subnormal Series** is a chain of subgroups,

$$G_0 = G \supseteq G_1 \supseteq \dots \supseteq 1 \in G_{i+1} \triangleleft G_i, \forall 0 \leq i \leq n-1.$$

Definition 1.49. $GL(n, F)$ is a **General Linear Group** of $n \times n$ matrix over the finite field \mathbb{F} .

Definition 1.50. $SL(n, F)$ is a **Special Linear Group** of $n \times n$ matrix over a finite field \mathbb{F} with determinant equal 1.

Definition 1.51. The $PGL(n, \mathbb{F})$ is a **Projective General Linear Group** of $n \times n$ matrix over the finite field \mathbb{F} which formed by factoring GL by its center.

$$PGL(N, \mathbb{F}) = GL_n(\mathbb{F})/Z(GL(n, \mathbb{F})).$$

Definition 1.52. The $PSL(n, \mathbb{F})$ is a **Projective Special Linear Group** of $n \times n$ matrix over the finite field \mathbb{F} which formed by factoring SL by its center.

$$PSL(N, \mathbb{F}) = L_n(\mathbb{F}) = SL_n(\mathbb{F})/Z(SL(n, \mathbb{F})).$$

Definition 1.53. The **Minimal Normal Subgroup** is a direct product of the simple groups.

Definition 1.54. Let G be a group. If $K \leq G$, the **Normalizer** of K in G is defined by

$$N_G(K) = \{a \in G \mid aKa^{-1} = K\}$$

Definition 1.55. Let G be a group. If $K \leq G$, the **Centralizer** of K in G is:

$$C_G(K) = \{x \in G : [x, k] = 1 \forall k \in K\}.$$

Definition 1.56. Let G be a group and X be a G -set. X is **Transitive** if

$$\forall x, y \in X, \exists a g \in G \text{ such that } y = gx.$$

Definition 1.57. If group G has a composition series, the factor groups of its series are the **Composition Factors** of G .

Definition 1.58. Let X be a set and δ by a family of words on X . A group G has **Generators** X and **Relations** δ if $G \cong K/R$, where K is a free group with basis X and R is the normal subgroup of K generated by δ . We say $\langle X \mid \delta \rangle$ is a **Presentation** of G .

Definition 1.59. Let X be a G -set. X is **Primitive** if X has no nontrivial blocks. If X is primitive, the only blocks of X are $H = X$ and $H = \emptyset$.

1.2 Group Extension Preliminaries

Definition 1.60. The **Group Extension** is an extension of a group N by a group K with a normal subgroup H such that

$$H \cong N \text{ and } G/H \cong K.$$

Definition 1.61. The **Central Extension** is the extension that N is the center of G if G is a central extension of N by K which is based on

$$\psi : K \times K \rightarrow N. (n_1, k_1) * (n_2, k_2) = (n_1 * n_2 * \psi(k_1, k_2)k_1k_2).$$

Definition 1.62. The **Semi-direct Product** is a group extension composed by H and Q . $G = H : Q$ when $H \triangleleft G$. H has a complement $Q_1 \cong Q$.

Definition 1.63. The **Mixed Extension** is the extension combined the properties of a semi-product and a central extension. (N is a normal subgroup and it is not a central of the group)

$$\phi : K \rightarrow \text{Aut}(N) \text{ and } \psi : K \times K \rightarrow N.$$

$$N \bullet K : (n_1, k_1) * (n_2, k_2) = (n_1 * k_2^{k_1} * \psi(k_1, k_2), k_1k_2).$$

1.3 Theorems

Theorem 1.64. (Lagrange) If G is a finite group and $H \leq G$, then $|H|$ divides $|G|$ and $[G : H] = |G|/|H|$.

Theorem 1.65. Every permutation $\alpha \in S_n$ is either a **cycle** or a product of **disjoint cycles**.

Theorem 1.66. (Quotient Group). If $H \triangleleft G$, then the coset H in G form a group G/H of order $[G : H]$.

Theorem 1.67. (First Isomorphism Theorem). Let $\phi : G \rightarrow H$ be a homomorphism with $\ker\phi$ then,

- $[\ker\phi \triangleleft G]$,
- $[G/\ker\phi \cong \text{im}\phi]$.

Theorem 1.68. (Second Isomorphism Theorem). Let $H, K \leq G$ and $H \triangleleft G$ then,

- $[H \cap K \triangleleft K]$,
- $[K/H \cap K \cong HK/H]$.

Theorem 1.69. (Third Isomorphism Theorem). Let $K \leq H \leq G$, where both H and K are normal subgroups of G then,

$$G/k/H \cong G/H.$$

Theorem 1.70. (Maximal Normal Subgroup). H is a maximal normal subgroup of G if there is no normal subgroup K of G with

$$H < K < G.$$

Theorem 1.71. (Feit-Thompson). Every simple group is generated by involution which every element of order 2.

Theorem 1.72. Let G be a group with normal subgroups H and K if,

- $HK = G$,

- $H \cap K = 1$,

then $G \cong H \times K$.

Theorem 1.73. *If $a \in G$, the number of conjugates of a is equal to the index of its centralizer.*

$$|a^G| = [G : C_G(a)].$$

Theorem 1.74. *Let $f : (G, *) \rightarrow (G', \circ)$ be a **Homomorphism** then,*

- $f(e) = e'$, where e' is the identity in G' ,
- If $a \in G$, then $f(a^{-1}) = f(a)^{-1}$,
- If $a \in G$ and $n \in \mathbb{Z}$, then $f(a^n) = f(a)^n$.

Theorem 1.75. *The intersection of any family of subgroups of a group G is again a **Subgroup** of G .*

Theorem 1.76. *If H and K are subgroups of a finite group G , then*

$$|HK||H \cap K| = |H||K|.$$

Theorem 1.77. *Every group G can be imbedded as a subgroup of S_G . In particular, if $|G| = n$, then G can be imbedded in S_n .*

Theorem 1.78. *If $K \leq G$ and $[G : K] = n$, then there is a homomorphism $\rho : G \rightarrow S_n$ with $\ker \rho \leq K$. The homomorphism ρ is called the **representation** of G on the cosets of K .*

Theorem 1.79. *If X is a G -set with action α , then there is a homomorphism $\tilde{\alpha} : S_X$ given by $\tilde{\alpha} : x \mapsto gx = \alpha(g, x)$. Conversely, every homomorphism $\varphi : G \rightarrow S_X$ defines an action, $gx = \varphi(g)x$ which makes X into a G -set.*

Theorem 1.80. *The **Jordan-Hölder Theorem** says every two composition series of a group G are equivalent.*

1.4 Lemmas

Lemma 1.81. *Let X be a G -set, and let $xy \in X$.*

- *If $K \leq G$, then $Kx \cap Ky \neq \emptyset$ implies $Kx = Ky$,*
- *If $K \triangleleft G$, then the subsets Kx are **Blocks** of X .*

Lemma 1.82. *The **Iwasawa's Lemma** says, G is **Simple** if the following hold true:*

- *G is faithful,*
- *G is primitive,*
- *G is perfect ($G = G'$),*
- *There exists an $x \in X$ and an abelian normal subgroup $H \triangleleft G_x$ whose conjugates $\{gKg^{-1} : g \in G\}$ generate G .*

1.5 Preliminary for Monomial Presentations

Definition 1.83. A **Representation** of a finite group G is defined by $\phi : G \xrightarrow{\text{Homo}} GL(n; \mathbb{F})$, where $GL(n; \mathbb{F})$ is a group of $n \times n$ invertible matrices over a finite field F .

Definition 1.84. The **Character** χ afforded by the representation $\rho : G \rightarrow GL(n, \mathbb{F})$ is a function $\chi : G \rightarrow \mathbb{F}$ given by $\chi(g) = \text{Tr}(g\rho) \forall g \in G$.

Definition 1.85. Let $\rho : G \xrightarrow{\text{homo}} GL(n, \mathbb{F})$ and $T \in GL(n, \mathbb{F})$. Then, $T^{-1}\rho T$ is also a representation of G and $T^{-1}\rho T$ and ρ are called **Equivelent**.

Definition 1.86. Let $\rho : G \xrightarrow{\text{Rep}} GL(n, \mathbb{F})$ and $\ker \rho = \{g \in G \mid g\rho = I_n\}$. Then, ρ is **Faithful** if $\ker \rho = 1$.

Definition 1.87. A representation $\rho : G \xrightarrow{\text{Rep}} GL(n, \mathbb{F})$ is given by $g\rho = F_n$ is a **Trivial Representation** of G .

- $\chi(x) = \chi(y)$ if x and y are conjugates.
- Equivelent representation have the same character.
- The number of irreducible character of G is equal to the number of the conjugacy classes of G .

Definition 1.88. The **Trivial Character** is the character χ of the trivial representation, where $\chi : G \rightarrow \mathbb{T}$ given by $\chi(x) = 1 \forall g \in G$.

Definition 1.89. We call square matrix that has exactly one non-zero entry in each row and each column **Monomial Matix**.

Definition 1.90. Let G be a group, the **Monomial Representation** is a map $M : G \xrightarrow{\text{Homo}} GL(n, \mathbb{F})$ that provide which $M(x)$ and $M(y)$ are monomial matrices.

Definition 1.91. A character α of G is monomial if α is induced by a linear character of a subgroup K of G .

Definition 1.92. Let $K \leq G$ and α be a character of G . Then the formula of induced character is $\phi_x^G = \frac{n}{h_x}$

Chapter 2

Construction of $7^2 : D_6$

2.1 Double Coset Enumeration of $7^2 : D_6$

We factor the group $G = \langle x, y, t | y^2, (x^{-1} * y)^2, x^{14}, t^2, (t, y * x^2) \rangle$ factored by $[x^3 * t]^3$ and $[x^5 * t]^3$, where $G = D_{14} = \langle x, y \rangle$ with $x \sim (1, 2, 3, 4, 5, 6, 7, 8, 9, 10, 11, 12, 13, 14)$, $y \sim (1, 13)(2, 12)(3, 11)(4, 10)(5, 9)(6, 8)$, and let $t \sim t_1$.

$$\begin{aligned} \text{Now } (x^3t)^3 &= e \\ \implies x^3t_1x^3t_1x^3t_1 &= e \\ \implies x^9t_1^6t_1^3t_1 &= e \\ \implies x^9t_7t_4t_1 &= e \end{aligned}$$

So $x^9t_7t_4 = t_1$. We also have $Nt_7t_4 = Nt_1$

$$\begin{aligned} \text{Also, } (x^5t)^3 &= e \\ x^5t_1x^5t_1x^5t_1 &= e \\ \implies x^{15}t_1^{10}t_1^5t_1 &= e \\ \implies x^{15}t_{11}t_6t_1 &= e. \end{aligned}$$

So $x^{15}t_{11}t_6 = t_1$. We also have

$Nt_{11}t_6 = Nt_1$. Thus,

$$\begin{aligned} t_{11}t_6t_1 &= (1, 14, 13, 12, 11, 10, 9, 8, 7, 6, 5, 4, 3, 2), \\ t_7t_4t_1 &= (1, 6, 11, 2, 7, 12, 3, 8, 13, 4, 9, 14, 5, 10), \dots \end{aligned}$$

We use our technique of double coset enumeration to show that $|G| = \left| \frac{7^2 \cdot D_6}{[x^3 * t]^3, [x^5 * t]^3} \right| \leq 588$. In order to obtain the index of N in G we shall perform a manual double coset enumeration of G over N ; thus we must find all double cosets $[w] = NwN$ and work out how many single cosets each of them contains. We shall know that we have completed the double coset enumeration when the set of right cosets obtained is closed under right multiplication by the t'_i s. Moreover, the completion test above is best performed by obtaining the orbits of $N^{(w)}$ on the symmetric generators. We need only identify, for each $[w]$, the double coset to which the right coset Nwt_i belongs for one symmetric generator t_i from each orbit.

Word of length 0

- NeN is denoted by $[*]$.

$NeN = \{N\}$. The number of right cosets in $[*]$ is equal to $\frac{|N|}{|N|} = \frac{28}{28} = 1$. Since N is transitive on $\{1, 2, 3, 4, 5, 6, 7, 8, 9, 10, 11, 12, 13, 14\}$, the orbit of N on $\{1, 2, 3, 4, 5, 6, 7, 8, 9, 10, 11, 12, 13, 14\}$ is $\{1, 2, 3, 4, 5, 6, 7, 8, 9, 10, 11, 12, 13, 14\}$.

Word of length 1

- Nt_1N is denoted by $[1]$

$$N^1 = \langle (2, 14)(3, 13)(4, 12)(5, 11)(6, 10)(7, 9) \rangle = N^{(1)}.$$

The number of right cosets in $[1]$ is equal to

$\frac{|N|}{|N^{(1)}|} = \frac{28}{2} = 14$. The orbits of $N^{(1)}$ on $\{1, 2, 3, 4, 5, 6, 7, 8, 9, 10, 11, 12, 13, 14\}$ are $\{1\}, \{8\}, \{2, 14\}, \{3, 13\}, \{4, 12\}, \{5, 11\}, \{6, 10\}$, and $\{7, 9\}$.

We pick a representative, say t_i , from each orbit and determine the double coset that contains Nt_i .

$Nt_1t_1 \in [*]$ (1 symmetric generator symmetric generator goes back to the double coset $[*]$), since $t_1^2 = e$.

$Nt_1t_2 \in [1]$ (1 symmetric generator goes back to the double coset $[1]$), since $t_1 * t_2 = x^3 * t_3$

$Nt_1t_8 \in [1]$ (1 goes back to the double coset [1]), since $t_1 * t_8 = x^7 * t_1$.

$Nt_1t_4 \in [1]$ (2 symmetric generators go back to the double coset [1]), since $t_1 * t_4 = x^{-5} * t_7$.

$Nt_1t_6 \in [1]$ (2 symmetric generators go back to the double coset [1]), $t_1 * t_6 = x * t_{11}$.

Thus, t_1 takes [1] to [*] and $t_2, t_{14}, t_8, t_4, t_{12}, t_6, t_{10}$ take [1] to itself.

Word of length 2

- Nt_1t_3N is denoted by [13].

We note that $N^{(1,3)} \geq N^{13} = 1$. Now $t_1t_3 = t_3t_5 \implies$

$(1, 3, 5, 7, 9, 11, 13)(2, 4, 6, 8, 10, 12, 14) \in N^{(13)}$

and $t_1t_3 = x^6t_{12}t_{10} \implies$

$(1, 12)(2, 11)(3, 10)(4, 9)(5, 8)(6, 7)(13, 14) \in N^{(13)}$. Thus

$N^{(13)} \geq < (1, 3, 5, 7, 9, 11, 13)(2, 4, 6, 8, 10, 12, 14),$

$(1, 12)(2, 11)(3, 10)(4, 9)(5, 8)(6, 7)(13, 14) > \cong D_7$.

The number of right cosets in [13] is equal to $\frac{|N|}{|N^{(13)}|} = \frac{28}{14} = 2$.

The orbit of $N^{(13)}$ on $\{1, 2, 3, 4, 5, 6, 7, 8, 9, 10, 11, 12, 13, 14\}$ is

$\{1, 3, 12, 14, 10, 2, 13, 7, 8, 4, 11, 9, 6, 5\}$.

We now take the representative 3 of the orbit

$\{1, 2, 3, 4, 5, 6, 7, 8, 9, 10, 11, 12, 13, 14\}$.

and determine that $Nt_1t_3t_3 = Nt_1 \in [1]$. So all of the fourteen t'_i s take [13] to [1].

- Nt_1t_5N is denoted by [15].

We have $N^{(15)} \geq N^{15} = 1$.

Now $t_1t_5 = t_3t_7$ implies

$(1, 3, 5, 7, 9, 11, 13)(2, 4, 6, 8, 10, 12, 14)$

$\in N^{(15)}$ and $t_1t_5 = x^{-2}t_{14}t_{10} \implies$

$(1, 14)(2, 13)(3, 12)(4, 11)(5, 10)(6, 9)(7, 8)$

$\in N^{(15)}$. Thus $N^{(15)} \geq$

$< (1, 3, 5, 7, 9, 11, 13)(2, 4, 6, 8, 10, 12, 14),$

$(1, 14)(2, 13)(3, 12)(4, 11)(5, 10)(6, 9)(7, 8) >\cong D_7$.

The number of right cosets in [15] is equal to $\frac{|N|}{|N^{(15)}|} = \frac{28}{14} = 2$.

The orbit of $N^{(15)}$ on $\{1, 2, 3, 4, 5, 6, 7, 8, 9, 10, 11, 12, 13, 14\}$ is $\{1, 2, 3, 4, 5, 6, 7, 8, 9, 10, 11, 12, 13, 14\}$. We now take the representative 5 of the orbit

$\{1, 2, 3, 4, 5, 6, 7, 8, 9, 10, 11, 12, 13, 14\}$

and determine that $Nt_1t_5t_5 = Nt_1 \in [1]$. So all of the fourteen t'_i s take [15] to [1].

- Nt_1t_7N is denoted by [17]

We have $N^{(17)} \geq N^{17} = 1$.

Now $t_1t_7 = t_3t_9$ implies

$(1, 3, 5, 7, 9, 11, 13)(2, 4, 6, 8, 10, 12, 14) \in N^{(17)}$

and $t_1t_7 = x^4t_{12}t_6 \implies$

$(1, 12)(2, 11)(3, 10)(4, 9)(5, 8)(6, 7)(13, 14) \in N^{(17)}$.

Thus $N^{(17)} \geq (1, 3, 5, 7, 9, 11, 13)(2, 4, 6, 8, 10, 12, 14)$,

$(1, 12)(2, 11)(3, 10)(4, 9)(5, 8)(6, 7)(13, 14) >\cong D_7$.

We now take the representative 7 of the orbit

$\{1, 2, 3, 4, 5, 6, 7, 8, 9, 10, 11, 12, 13, 14\}$

and determine that $Nt_1t_7t_7 = Nt_1 \in [1]$. So all of the fourteen t'_i s take [17] to [1].

The number of right cosets in [17] is equal to $\frac{|N|}{|N^{(17)}|} = \frac{28}{14} = 2$.

The orbit of $N^{(17)}$ on $\{1, 2, 3, 4, 5, 6, 7, 8, 9, 10, 11, 12, 13, 14\}$ is

$\{1, 3, 12, 14, 5, 10, 2, 13, 7, 8, 4, 11, 9, 6\}$.

Now, we can construct the Cayley diagram, since the set of right cosets are closed under right multiplication by t'_i s

where $i = 1, 2, 3, 4, 5, 6, 7, 8, 9, 10, 11, 12, 13, 14$, and determine the index of N in G . We conclude that

$$\begin{aligned} |G| &= \left| \frac{7^2:D_6}{[x^3*t]^3, [x^5*t]^3} \right|, \\ |G| &\leq (|N| + \frac{|N|}{|N^{(1)}|} + \frac{|N|}{|N^{(13)}|} + \frac{|N|}{|N^{(15)}|} + \frac{|N|}{|N^{(17)}|}) \times |N| \\ &\implies |G| \leq (1 + 14 + 2 + 2 + 2) \times 28 \\ &\implies |G| \leq (21 \times 28) \\ &\implies |G| \leq 588 \end{aligned}$$

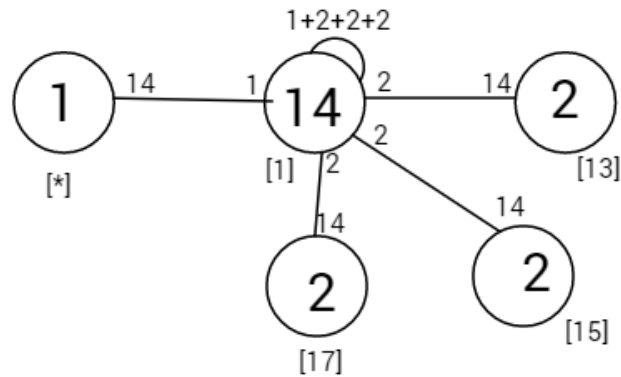
Figure 2.1: Cayley diagram of $7^2 : D_6$ over D_{14}

2.2 Proof of $G \cong 7^2 : D_6$

We determine the permutation representation G_1 of G on the 21 right cosets of $N = \langle x, y \rangle$ in G . We now demonstrate that the isomorphism type of G_1 is $7^2 : D_6$.

```
G<x,y,t>:=Group<x,y,t|y^2,(x^(-1)*y)^2,x^(14),
t^2,(t,y*x^2),(x^3*t)^3,(x^5*t)^3>;
#G
f,G1,k:=CosetAction(G,sub<G|x,y>);
```

The following composition factors and the normal lattice suggest that $NL[2]$ is an abelian normal subgroup of G_1 .

```
CompositionFactors(G1);
G
| Cyclic(2)
*
| Cyclic(3)
*
| Cyclic(2)
*
| Cyclic(7)
*
| Cyclic(7)
1
```

```
NL:=NormalLattice(G1);
NL;
```

Normal subgroup lattice

```
[8] Order 588 Length 1 Maximal Subgroups: 5 6 7
----
[7] Order 294 Length 1 Maximal Subgroups: 4
[6] Order 294 Length 1 Maximal Subgroups: 4
[5] Order 294 Length 1 Maximal Subgroups: 3 4
----
[4] Order 147 Length 1 Maximal Subgroups: 2
[3] Order 98 Length 1 Maximal Subgroups: 2
----
[2] Order 49 Length 1 Maximal Subgroups: 1
----
[1] Order 1 Length 1 Maximal Subgroups:
IsAbelian(NL[2]);
true
```

Now $NL[2] \cong 7^2$. A presentation of 7^2 is $7^2 = \langle a, b \mid a^7, b^7, (a, b) \rangle$.

```
X:=AbelianGroup(GrpPerm, [7, 7]);
IsIsomorphic(X, NL[2]);
true
```

The quotient group $q = G1/NL[2]$ is the dihedral group D_6 with presentation

```
q = \{c, d, e \mid c^2, d^2, e^2, (cd)^2, (de)^2, (ec)^3\}.
q, ff:=quo<G1|NL[2]>;
```

```
q;
```

Permutation group q acting on a set of cardinality 6

```
Order = 12 = 2^2 * 3
```

```
(3, 5)(4, 6)
```

```
(1, 2)(3, 4)(5, 6)
```

```
(1, 3)(2, 4)
```

```
IsAbelian(q);
false
```

```
FPGroup(q);
```

```
Finitely presented group on 3 generators Relations
.1^2 = Id
```

```
.2^2 = Id
.3^2 = Id
(.1 * .2)^2 = Id
(.2 * .3)^2 = Id
(.3 * .1)^3 = Id
```

Thus G_1 is a semi-direct product of 7^2 by D_6 .
 The action of D_6 on 7^2 is $a^c=a^6*b$, $a^d=a^6$, $a^e=a^2*b^6$,
 $b^c=b$, $b^d=b^6$, $b^e=a^3*b^5$. Hence, a presentation of $D_6:7^2$
 is given by $\{a,b,c,d,e \mid a^7, b^7, (a,b), c^2, d^2, e^2, (c*d)^2,$
 $(d*e)^2, (e*c)^3, a^c=a^6*b, a^d=a^6, a^e=a^2*b^6, b^c=b, b^d=b^6,$
 $b^e=a^3*b^5\}$. We finally verify that $G_1 = D_6:7^2$.

```
T:=Transversal(G1,NL[2]);
ff(T[2]) eq q.1;
true
ff(T[3]) eq q.2;
true
ff(T[4]) eq q.3;
true
for i,j in [0..6] do if NL[2].1^T[2] eq
NL[2].1^i*NL[2].2^j then i,j; end if; end for;
6 1
for i,j in [0..6] do if NL[2].1^T[3] eq
NL[2].1^i*NL[2].2^j then i,j; end if; end for;
6 0
for i,j in [0..6] do if NL[2].1^T[4] eq
NL[2].1^i*NL[2].2^j then i,j; end if; end for;
2 6
for i,j in [0..6] do if NL[2].2^T[2] eq
NL[2].1^i*NL[2].2^j then i,j; end if; end for;
0 1
for i,j in [0..6] do if NL[2].2^T[3] eq
NL[2].1^i*NL[2].2^j then i,j; end if; end for;
0 6
for i,j in [0..6] do if NL[2].2^T[4] eq
NL[2].1^i*NL[2].2^j then i,j; end if; end for;
3 5
GG<a,b,c,d,e>:=Group<a,b,c,d,e|a^7,b^7,(a,b),c^2
,d^2,e^2,(c*d)^2,(d*e)^2,(e*c)^3,
a^c=a^6*b, a^d=a^6,a^e=a^2*b^6
,b^c=b,b^d=b^6,b^e=a^3*b^5>;
#GG;
588
```

```
f1,GG1,k1:=CosetAction(GG,sub<GG|Id(GG)>);
IsIsomorphic(GG1,G1);
true
```

2.3 Magma Work for $7^2 : D_6$

```
S:=Sym(14);
xx:=S!(1, 2, 3, 4, 5, 6, 7, 8, 9, 10, 11, 12, 13, 14);
yy:=S!(1, 13)(2, 12)(3, 11)(4, 10)(5, 9)(6, 8);
N:=sub<S|xx,yy>;
#N;
28

G<x,y,t>:=Group<x,y,t|y^2,(x^-1*y)^2,x^14,t^2,(t,y*x^2),
(x^3*t)^3,(x^5*t)^3>;
#G;
588

f,G1,k:=CosetAction(G,sub<G|x,y>);
IN:=sub<G1|f(x),f(y)>;
CompositionFactors(G1);
G
| Cyclic(2)
*
| Cyclic(3)
*
| Cyclic(2)
*
| Cyclic(7)
*
| Cyclic(7)
1

#DoubleCosets(G,sub<G|x,y>,sub<G|x,y>);
5

DoubleCosets(G,sub<G|x,y>,sub<G|x,y>);
{ <GrpFP, Id(G), GrpFP>, <GrpFP, t * x^4 * y * t, GrpFP>,
<GrpFP, t * y * t, GrpFP>, <GrpFP, t, GrpFP>,
<GrpFP, t * x^2 * y * t, GrpFP> }
```

```

NN<a,b>:=Group<a,b|b^2, (a^-1*b)^2, a^14>;
Sch:=SchreierSystem(NN, sub<NN|Id(NN)>);
ArrayP:=[Id(N): i in [1..28]];
for i in [2..28] do
P:=[Id(N): l in [1..#Sch[i]]];
for j in [1..#Sch[i]] do
if Eltseq(Sch[i])[j] eq 1 then P[j]:=xx; end if;
if Eltseq(Sch[i])[j] eq -1 then P[j]:=xx^-1; end if;
if Eltseq(Sch[i])[j] eq 2 then P[j]:=yy; end if;
end for;
PP:=Id(N);
for k in [1..#P] do
PP:=PP*P[k]; end for;
ArrayP[i]:=PP;
end for;
for i in [1..28] do if ArrayP[i] eq N!(2, 14)(3, 13)(4, 12)
(5, 11)(6, 10)(7,9)
then Sch[i];
end if; end for;
b*a^2

prodim := function(pt, Q, I)
Return the image of pt under permutations Q[I]
applied sequentially.

v:=pt;
for i in I do
v:=v^(Q[i]);
end for;
return v;
end function;

<store t's>
ts := [ Id(G1): i in [1 .. 14] ];
ts[1]:=f(t);ts[2]:=f(t^x);ts[3]:=f(t^(x^2));
ts[4]:=f(t^(x^3));ts[5]:=f(t^(x^4));ts[6]:=f(t^(x^5));
ts[7]:=f(t^(x^6));ts[8]:=f(t^(x^7));ts[9]:=f(t^(x^8));
ts[10]:=f(t^(x^9));ts[11]:=f(t^(x^10));ts[12]:=f(t^(x^11));
ts[13]:=f(t^(x^12));ts[14]:=f(t^(x^13));

cst:= [null : i in [1 .. 21]]
where null is[Integers() |];
for i := 1 to 14 do

```

```

cst[prodim(1, ts, [i])] := [i];
end for;
m:=0; for i in [1..21] do if cst[i] ne []
then m:=m+1; end if; end for; m;
14

```

```

N1:=Stabiliser(N,1);
N1:=Stabiliser(N,[1]);
S:={[1]};
SS:=S^N;
SSS:=Setseq(SS);
for i in [1..#SS] do
for g in IN do
if ts[1] eq g*ts[Rep(SSS[i])[1]]
then print SSS[i];
end if; end for; end for;
{
[ 1 ]
}

```

```

N1s:=N1;
#N1s;
2

```

```

T1:=Transversal(N,N1s);
#T1;
14

```

```

T1:=Transversal(N,N1s);
for i := 1 to #T1 do
ss := [1]^T1[i];
cst[prodim(1, ts, ss)] := ss;
end for;
m:=0;for i in [1..21] do if cst[i] ne []
then m:=m+1; end if; end for; m;
14

```

```

Orbits(N1s);
[
GSet{@ 1 @},
GSet{@ 8 @},
GSet{@ 2, 14 @},
GSet{@ 3, 13 @},
GSet{@ 4, 12 @},

```

```

GSet{@ 5, 11 @},
GSet{@ 6, 10 @},
GSet{@ 7, 9 @}
]

for i in [1..21] do i, cst[i]; end for;
1 []
2 [ 1 ]
3 [ 2 ]
4 [ 13 ]
5 [ 14 ]
6 [ 3 ]
7 [ 12 ]
8 []
9 [ 4 ]
10 [ 11 ]
11 []
12 [ 5 ]
13 [ 10 ]
14 []
15 [ 6 ]
16 [ 9 ]
17 []
18 [ 7 ]
19 [ 8 ]
20 []
21 []

N18:=Stabiliser(N,[1,8]);
S:={ [1,8] };
SS:=S^N;
SSS:=Setseq(SS);
for i in [1..#SS] do
for g in IN do if ts[1]*ts[8]
eq g*ts[Rep(SSS[i])[1]]*ts[Rep(SSS[i])[2]]
then print SSS[i];
end if; end for; end for;
{
[ 1, 8 ]
}

N18s:=N18;
#N18s;
2

```

```

T18:=Transversal(N,N18s);
#T18;
14

for i := 1 to #T18 do
ss := [1,8]^T18[i];
cst[prodim(1, ts, ss)] := ss;
end for;
m:=0;
for i in [1..21] do if cst[i] ne [] then m:=m+1;
end if; end for; m;
14

Orbits(N18s);
[
GSet{@ 1 @},
GSet{@ 8 @},
GSet{@ 2, 14 @},
GSet{@ 3, 13 @},
GSet{@ 4, 12 @},
GSet{@ 5, 11 @},
GSet{@ 6, 10 @},
GSet{@ 7, 9 @}
]

for m,n in IN do if ts[1]*ts[8] eq m*(ts[1])^n then m,n;
end if;end for;

(2, 19) (3, 16) (4, 15) (5, 18) (6, 13) (7, 12) (8, 11) (9, 10)
(14, 17) (20, 21)
Id(IN)

m:=N!(1, 8) (2, 9) (13, 6) (14, 7) (3, 10) (12, 5) (4, 11);
n:=N!Id(IN);
[1]^n;
[ 1 ]

for i in [1 .. 28] do if ArrayP[i] eq m then Sch[i];
end if; end for;
a^7

ts[1]*ts[8] eq f(x^7)*ts[1];
true

```



```

N12:=Stabiliser(N,[1,2]);
S:={1,2};
SS:=S^N;
SSS:=Setseq(SS);
for i in [1..#SS] do
for g in IN do if ts[1]*ts[2]
eq g*ts[Rep(SSS[i])[1]]*ts[Rep(SSS[i])[2]]
then print SSS[i];
end if; end for; end for;
{
[ 1, 2 ]
}
{
[ 5, 4 ]
}

N12s:=N12;

for g in N do if 1^g eq 5 and 2^g eq 4
then N12s:=sub<N|N12s,g>; end if; end for;

#N12s;
2

T12:=Transversal(N,N12s);
#T12;
14

for i := 1 to #T12 do
ss := [1,2]^T12[i];
cst[prodim(1, ts, ss)] := ss;
end for;
m:=0;
for i in [1..21] do if cst[i] ne [] then m:=m+1;
end if; end for; m;
14

Orbits(N12s);
[
GSet{@ 3 @},
GSet{@ 10 @},
GSet{@ 1, 5 @},
GSet{@ 2, 4 @},

```

```

GSet{@ 6, 14 @},
GSet{@ 7, 13 @},
GSet{@ 8, 12 @},
GSet{@ 9, 11 @}
]

for m,n in IN do if ts[1]*ts[2] eq m*(ts[1])^n then m,n;
end if;end for;
(2, 9, 18, 13, 4, 3, 12, 19, 10, 5, 6, 15, 16, 7)(8, 11)
(14, 17)(20, 21)(2, 6, 12, 18, 16, 10, 4)(3, 9, 15, 19, 13, 7, 5)

m:=N!(1, 4, 7, 10, 13, 2, 5, 8, 11, 14, 3, 6, 9, 12);
n:=N!(1, 3, 5, 7, 9, 11, 13)(2, 4, 6, 8, 10, 12, 14);
[1]^n;
[ 3 ]

for i in [1 .. 21] do if ArrayP[i] eq m then Sch[i];
end if; end for;
a^3

ts[1]*ts[2] eq f(x^3)*ts[3];
true

N13:=Stabiliser(N, [1,3]);
S:={[1,3]};
SS:=S^N;
SSS:=Setseq(SS);
for i in [1..#SS] do
for g in IN do if ts[1]*ts[3]
eq g*ts[Rep(SSS[i])[1]]*ts[Rep(SSS[i])[2]]
then print SSS[i];
end if; end for; end for;
{
[ 1, 3 ]
}
{
[ 3, 5 ]
}
{
[ 12, 10 ]
}
{
[ 14, 12 ]
}

```

```

{
[ 5, 7 ]
}
{
[ 10, 8 ]
}
{
[ 2, 14 ]
}
{
[ 13, 1 ]
}
{
[ 7, 9 ]
}
{
[ 8, 6 ]
}
{
[ 4, 2 ]
}
{
[ 11, 13 ]
}
{
[ 9, 11 ]
}
{
[ 6, 4 ]
}

```

```
N13s:=N13;
```

```

for g in N do if 1^g eq 3 and 3^g eq 5
then N13s:=sub<N|N13s,g>; end if; end for;
for g in N do if 1^g eq 12 and 3^g eq 10
then N13s:=sub<N|N13s,g>; end if; end for;
for g in N do if 1^g eq 14 and 3^g eq 12
then N13s:=sub<N|N13s,g>; end if; end for;
for g in N do if 1^g eq 5 and 3^g eq 7
then N13s:=sub<N|N13s,g>; end if; end for;
for g in N do if 1^g eq 10 and 3^g eq 8
then N13s:=sub<N|N13s,g>; end if; end for;
for g in N do if 1^g eq 2 and 3^g eq 14

```

```

then N13s:=sub<N|N13s,g>; end if; end for;
for g in N do if 1^g eq 13 and 3^g eq 1
then N13s:=sub<N|N13s,g>; end if; end for;
for g in N do if 1^g eq 7 and 3^g eq 9
then N13s:=sub<N|N13s,g>; end if; end for;
for g in N do if 1^g eq 8 and 3^g eq 6
then N13s:=sub<N|N13s,g>; end if; end for;
for g in N do if 1^g eq 4 and 3^g eq 2
then N13s:=sub<N|N13s,g>; end if; end for;
for g in N do if 1^g eq 11 and 3^g eq 13
then N13s:=sub<N|N13s,g>; end if; end for;
for g in N do if 1^g eq 9 and 3^g eq 11
then N13s:=sub<N|N13s,g>; end if; end for;
for g in N do if 1^g eq 6 and 3^g eq 4
then N13s:=sub<N|N13s,g>; end if; end for;
#N13s;
14
for g in N do if 1^g eq 3 and 3^g eq 5 then g;
end if; end for;
(1, 3, 5, 7, 9, 11, 13)(2, 4, 6, 8, 10, 12, 14)

for n in IN do if ts[1]*ts[3] eq n*ts[3]*ts[5] then n;
end if; end for;
Id(IN)

ts[1]*ts[3] eq ts[3]*ts[5];
true

for n in IN do if ts[1]*ts[3] eq n*ts[12]*ts[10] then n;
end if; end for;
(2, 18, 4, 12, 10, 6, 16)(3, 19, 5, 15, 7, 9, 13)

N!(1,7,13,5,11,3,9)(2,8,14,6,12,4,10);
(1, 7, 13, 5, 11, 3, 9)(2, 8, 14, 6, 12, 4, 10)

for i in [1..28] do if ArrayP[i] eq N!(1, 7, 13, 5, 11,
3, 9)(2, 8, 14, 6, 1,2, 4, 10)
then Sch[i]; end if; end for;
a^6

ts[1]*ts[3] eq f(x^6)*ts[12]*ts[10];
for g in N do if 1^g eq 12 and 3^g eq 10 then g; end if;
end for;
(1, 12)(2, 11)(3, 10)(4, 9)(5, 8)(6, 7)(13, 14)

```

```

N13s:=sub<N| (1, 3, 5, 7, 9, 11, 13)(2, 4, 6, 8, 10,
12, 14),(1, 12)(2, 11)(3, 10)(4, 9)(5, 8)(6, 7)(13, 14)>;
T13:=Transversal(N,N13s);
#T13;
2

for i := 1 to #T13 do
ss := [1,3]^T13[i];
cst[prodim(1, ts, ss)] := ss;
end for;
m:=0;
for i in [1..21] do if cst[i] ne [] then m:=m+1; end if;
end for; m;
16

Orbits(N13s);
[
GSet{@ 1, 3, 12, 14, 5, 10, 2, 13, 7, 8, 4, 11, 9, 6 @}
]

for m,n in IN do if ts[1]*ts[3] eq m*(ts[1])^n then m,n;
end if;end for;

N14:=Stabiliser(N,[1,4]);
S:={ [1,4] };
SS:=S^N;
SSS:=Setseq(SS);
for i in [1..#SS] do
for g in IN do if ts[1]*ts[4]
eq g*ts[Rep(SSS[i])[1]]*ts[Rep(SSS[i])[2]]
then print SSS[i];
end if; end for; end for;
{
[ 1, 4 ]
}
{
[ 13, 10 ]
}

N14s:=N14;

for g in N do if 1^g eq 13 and 4^g eq 10
then N14s:=sub<N|N14s,g>; end if; end for;

```

```

#N14s;
2

T14:=Transversal(N,N14s);
#T14;
14

for i := 1 to #T14 do
ss := [1,4]^T14[i];
cst[prodim(1, ts, ss)] := ss;
end for;
m:=0;
for i in [1..21] do if cst[i] ne [] then m:=m+1;
end if; end for; m;
16

Orbits(N14s);
[
GSet{@ 7 @},
GSet{@ 14 @},
GSet{@ 1, 13 @},
GSet{@ 2, 12 @},
GSet{@ 3, 11 @},
GSet{@ 4, 10 @},
GSet{@ 5, 9 @},
GSet{@ 6, 8 @}
]

for m,n in IN do if ts[1]*ts[4] eq m*(ts[1])^n then m,n;
end if;end for;
(2, 13, 12, 5, 16, 9, 4, 19, 6, 7, 18, 3, 10, 15)(8, 11)
(14, 17)(20, 21)(2, 18, 4, 12, 10, 6, 16)(3, 19, 5, 15, 7,
9, 13)

for m,n in IN do if ts[1]*ts[4] eq m*(ts[1]*ts[3])^n then
m,n; end if;end for;

m:=N!(1, 10, 5, 14, 9, 4, 13, 8, 3, 12, 7, 2, 11, 6);
n:=N!(1, 7, 13, 5, 11, 3, 9)(2, 8, 14, 6, 12, 4, 10);
[1]^n;
[ 7 ]

for i in [1 .. 21] do if ArrayP[i] eq m then Sch[i];

```

```

end if; end for;
a^-5

ts[1]*ts[4] eq f(x^-5)*ts[7];
true

N15:=Stabiliser(N, [1, 5]);
S:={ [1, 5] };
SS:=S^N;
SSS:=Setseq(SS);
for i in [1..#SS] do
for g in IN do if ts[1]*ts[5]
eq g*ts[Rep(SSS[i])[1]]*ts[Rep(SSS[i])[2]]
then print SSS[i];
end if; end for; end for;
{
[ 1, 5 ]
}
{
[ 3, 7 ]
}
{
[ 12, 8 ]
}
{
[ 14, 10 ]
}
{
[ 5, 9 ]
}
{
[ 10, 6 ]
}
{
[ 2, 12 ]
}
{
[ 13, 3 ]
}
{
[ 7, 11 ]
}
{
[ 8, 4 ]
}

```

```

}
{
[ 4, 14 ]
}
{
[ 11, 1 ]
}
{
[ 9, 13 ]
}
{
[ 6, 2 ]
}

```

```
N15s:=N15;
```

```

for g in N do if 1^g eq 3 and 5^g eq 7
then N15s:=sub<N|N15s,g>; end if; end for;
for g in N do if 1^g eq 12 and 5^g eq 8
then N15s:=sub<N|N15s,g>; end if; end for;
for g in N do if 1^g eq 14 and 5^g eq 10
then N15s:=sub<N|N15s,g>; end if; end for;
for g in N do if 1^g eq 5 and 5^g eq 9
then N15s:=sub<N|N15s,g>; end if; end for;
for g in N do if 1^g eq 10 and 5^g eq 6
then N15s:=sub<N|N15s,g>; end if; end for;
for g in N do if 1^g eq 2 and 5^g eq 12
then N15s:=sub<N|N15s,g>; end if; end for;
for g in N do if 1^g eq 13 and 5^g eq 3
then N15s:=sub<N|N15s,g>; end if; end for;
for g in N do if 1^g eq 7 and 5^g eq 11
then N15s:=sub<N|N15s,g>; end if; end for;
for g in N do if 1^g eq 8 and 5^g eq 4
then N15s:=sub<N|N15s,g>; end if; end for;
for g in N do if 1^g eq 11 and 5^g eq 1
then N15s:=sub<N|N15s,g>; end if; end for;
for g in N do if 1^g eq 9 and 5^g eq 13
then N15s:=sub<N|N15s,g>; end if; end for;
for g in N do if 1^g eq 6 and 5^g eq 2
then N15s:=sub<N|N15s,g>; end if; end for;

```

```
#N15s;
```

```
14
```



```

for n in IN do if ts[1]*ts[5] eq n*ts[3]*ts[7] then n;
end if; end for;
Id(IN)
for g in N do if 1^g eq 3 and 5^g eq 7 then g;
end if; end for;
(1, 3, 5, 7, 9, 11, 13)(2, 4, 6, 8, 10, 12, 14)

for g in N do if 1^g eq 14 and 5^g eq 10 then g;
end if; end for;
(1, 14)(2, 13)(3, 12)(4, 11)(5, 10)(6, 9)(7, 8)

for n in IN do if ts[1]*ts[5] eq n*ts[14]*ts[10] then n;
end if; end for;
(2, 4, 10, 16, 18, 12, 6)(3, 5, 7, 13, 19, 15, 9)

N!(1,13,11,9,7,5,3)(2,14,12,10,8,6,4);
for i in [1..28] do if ArrayP[i] eq N!(1,13,11,9,7,5,3)
(2,14,12,10,8,6,4)
then Sch[i]; end if; end for;
a^-2

ts[1]*ts[5] eq f(x^-2)*ts[14]*ts[10];
true

T15:=Transversal(N,N15s);
#T15;
2

for i := 1 to #T15 do
ss := [1,5]^T15[i];
cst[prodim(1, ts, ss)] := ss;
end for;
m:=0;
for i in [1..21] do if cst[i] ne [] then m:=m+1; end if;
end for; m;
18

Orbits(N15s);
[
GSet{@ 1, 3, 12, 14, 5, 10, 2, 13, 7, 8, 11, 9, 6, 4 @}
]

for m,n in IN do if ts[1]*ts[5] eq m*(ts[1])^n then m,n;
end if;end for;

```

```

for m,n in IN do if ts[1]*ts[5] eq m*(ts[1]*ts[3])^n then
m,n; end if;end for;

```

```

N16:=Stabiliser(N,[1,6]);
S:={[1,6]};
SS:=S^N;
SSS:=Setseq(SS);
for i in [1..#SS] do
for g in IN do if ts[1]*ts[6]
eq g*ts[Rep(SSS[i])[1]]*ts[Rep(SSS[i])[2]]
then print SSS[i];
end if; end for; end for;
{
[ 1, 6 ]
}
{
[ 7, 2 ]
}

```

```

N16s:=N16;

```

```

for g in N do if 1^g eq 7 and 6^g eq 2
then N16s:=sub<N|N16s,g>; end if; end for;

```

```

#N16s;
2

```

```

T16:=Transversal(N,N16s);
#T16;
14

```

```

for i := 1 to #T16 do
ss := [1,6]^T16[i];
cst[prodim(1, ts, ss)] := ss;
end for;
m:=0;
for i in [1..21] do if cst[i] ne [] then m:=m+1;
end if; end for; m;
18

```

```

Orbits(N16s);
[
GSet{@ 4 @},
GSet{@ 11 @},

```

```

GSet{@ 1, 7 @},
GSet{@ 2, 6 @},
GSet{@ 3, 5 @},
GSet{@ 8, 14 @},
GSet{@ 9, 13 @},
GSet{@ 10, 12 @}
]

for m,n in IN do if ts[1]*ts[6] eq m*(ts[1])^n then m,n;
end if;end for;
(2, 3, 6, 9, 12, 15, 18, 19, 16, 13, 10, 7, 4, 5)(8, 11)
(14, 17)(20, 21)(2, 10, 18, 6, 4, 16, 12)(3, 7, 19, 9,
5, 13, 15)

for m,n in IN do if ts[1]*ts[6] eq m*(ts[1]*ts[3])^n then
m,n; end if;end for;
for m,n in IN do if ts[1]*ts[6] eq m*(ts[1]*ts[5])^n then
m,n; end if;end for;

m:=N!(1, 2, 3, 4, 5, 6, 7, 8, 9, 10, 11, 12, 13, 14);
n:=N!(1, 11, 7, 3, 13, 9, 5)(2, 12, 8, 4, 14, 10, 6);
[1]^n;
[ 11 ]

for i in [1 .. 21] do if ArrayP[i] eq m then Sch[i];
end if; end for;
a

ts[1]*ts[6] eq f(x)*ts[11];
true

N17:=Stabiliser(N, [1,7]);
S:={[1,7]};
SS:=S^N;
SSS:=Setseq(SS);
for i in [1..#SS] do
for g in IN do if ts[1]*ts[7]
eq g*ts[Rep(SSS[i])[1]]*ts[Rep(SSS[i])[2]]
then print SSS[i];
end if; end for; end for;
{
[ 1, 7 ]
}
{

```

```

[ 3, 9 ]
}
{
[ 12, 6 ]
}
{
[ 14, 8 ]
}
{
[ 5, 11 ]
}
{
[ 10, 4 ]
}
{
[ 2, 10 ]
}
{
[ 13, 5 ]
}
{
[ 7, 13 ]
}
{
[ 8, 2 ]
}
{
[ 4, 12 ]
}
{
[ 11, 3 ]
}
{
[ 9, 1 ]
}
{
[ 6, 14 ]
}

```

```
N17s:=N17;
```

```

for g in N do if 1^g eq 3 and 7^g eq 9
then N17s:=sub<N|N17s,g>; end if; end for;
for g in N do if 1^g eq 12 and 7^g eq 6

```

```

then N17s:=sub<N|N17s,g>; end if; end for;
for g in N do if 1^g eq 14 and 7^g eq 8
then N17s:=sub<N|N17s,g>; end if; end for;
for g in N do if 1^g eq 5 and 7^g eq 11
then N17s:=sub<N|N17s,g>; end if; end for;
for g in N do if 1^g eq 10 and 7^g eq 4
then N17s:=sub<N|N17s,g>; end if; end for;
for g in N do if 1^g eq 2 and 7^g eq 10
then N17s:=sub<N|N17s,g>; end if; end for;
for g in N do if 1^g eq 13 and 7^g eq 5
then N17s:=sub<N|N17s,g>; end if; end for;
for g in N do if 1^g eq 7 and 7^g eq 13
then N17s:=sub<N|N17s,g>; end if; end for;
for g in N do if 1^g eq 8 and 7^g eq 2
then N17s:=sub<N|N17s,g>; end if; end for;
for g in N do if 1^g eq 4 and 7^g eq 12
then N17s:=sub<N|N17s,g>; end if; end for;
for g in N do if 1^g eq 11 and 7^g eq 3
then N17s:=sub<N|N17s,g>; end if; end for;
for g in N do if 1^g eq 9 and 7^g eq 1
then N17s:=sub<N|N17s,g>; end if; end for;
for g in N do if 1^g eq 6 and 7^g eq 14
then N17s:=sub<N|N17s,g>; end if; end for;

#N17s;
14
for n in IN do if ts[1]*ts[7] eq n*ts[3]*ts[9] then
n; end if; end for;
Id(IN)

ts[1]*ts[7] eq ts[3]*ts[9];
true

for g in N do if 1^g eq 3 and 7^g eq 9 then g;
end if; end for;
(1, 3, 5, 7, 9, 11, 13)(2, 4, 6, 8, 10, 12, 14)

for n in IN do if ts[1]*ts[7] eq n*ts[12]*ts[6] then
n; end if; end for;
(2, 12, 16, 4, 6, 18, 10)(3, 15, 13, 5, 9, 19, 7)

N!(1,5,9,13,3,7,11)(2,6,10,14,4,8,12);
for i in [1..28] do if ArrayP[i] eq N!(1, 5, 9, 13,
3, 7, 11)(2, 6, 10, 14,4, 8, 12) then Sch[i]; end if;

```

```

end for;
a^4

ts[1]*ts[7] eq f(x^4)*ts[12]*ts[6];
true

for g in N do if 1^g eq 12 and 7^g eq 6 then g;
end if; end for;
(1, 12) (2, 11) (3, 10) (4, 9) (5, 8) (6, 7) (13, 14)

T17:=Transversal(N,N17s);
#T17;
2

for i := 1 to #T17 do
ss := [1,7]^T17[i];
cst[prodim(1, ts, ss)] := ss;
end for;
m:=0;
for i in [1..21] do if cst[i] ne [] then m:=m+1;
end if; end for; m;
20

Orbits(N17s);
[
GSet{@ 1, 3, 12, 14, 5, 10, 2, 13, 7, 8, 4, 11, 9, 6 @}
]

for m,n in IN do if ts[1]*ts[7] eq m*(ts[1])^n then m,n;
end if;end for;
for m,n in IN do if ts[1]*ts[7] eq m*(ts[1]*ts[3])^n
then m,n; end if;end for;
for m,n in IN do if ts[1]*ts[7] eq m*(ts[1]*ts[5])^n
then m,n; end if;end for;

```

Chapter 3

Construction of $2^4 : (5 : 4)$

3.1 Double Coset of Enumeration of $2^4 : (5 : 4)$

We factor the group $G = D_5 = \langle x, y, t | x^5, y^4, y^{-1} * x^{-2} * y * x^{-1}, t^2, (t, y) \rangle$ by the 3 relation $[x^{-2} * y^{-2} * t^{x^3}]^4$, $[y^{-1} * x^{-1} * t]^8$ and $[x^2 * t]^5$, where $N = \langle x, y \rangle$ with $x \sim (1, 2, 4, 5, 3)$, $y \sim (2, 4, 3, 5)$, and let $t \sim t_1$.

$$\begin{aligned}
 & \text{Now } (x^{-2} * y^{-2} * t^{x^3})^4 = e \\
 \implies & x^{-2}y^{-2}t_5x^{-2}y^{-2}t_5x^{-4}y^{-4}t_5^{x^{-2}y^{-2}}t_5 = e \\
 \implies & x^{-2}y^{-2}t_5x^{-6}y^{-6}t_5t_1t_5 = e \\
 \implies & x^{-8}y^{-8}t_1t_5 = e \\
 \text{So } & x^{-8}y^{-8}t_1 = t_5. \text{ We also have } Nt_1 = Nt_5. \\
 & (y^{-1} * x^{-1} * t)^8 = e \\
 \implies & y^{-1}x^{-1}t_1y^{-1}x^{-1}t_1y^{-1}x^{-1}t_1y^{-1}x^{-1}t_1y^{-1}x^{-1}t_1y^{-1}x^{-1}t_1y^{-1}x^{-1}t_1y^{-2}x^{-2}t_3t_1 = e \\
 \implies & y^{-1}x^{-1}t_1y^{-1}x^{-1}t_1y^{-1}x^{-1}t_1y^{-5}x^{-5}t_1t_4t_2t_3t_1 = e \\
 \implies & y^{-8}x^{-8}t_4t_2t_3t_1t_4t_2t_3t_1 = e
 \end{aligned}$$

So $y^{-8}x^{-8}t_4t_2t_3t_1t_4t_2t_3 = t_1$. We also have $Nt_4t_2t_3t_1t_4t_2t_3 = Nt_1$

$$\begin{aligned}
 & \text{Also, } (x^2 * t)^5 = e \\
 \implies & x^2t_1x^2t_1x^2t_1x^4t_4t_1 = e \\
 \implies & x^2t_1x^8t_2t_3t_4t_1 = e
 \end{aligned}$$

$$\implies x^{10}t_5t_2t_3t_4t_1 = e.$$

So $x^{10}t_5t_2t_3t_4 = t_1$. We also have $Nt_5t_2t_3t_4 = Nt_1$. Thus,

$$\begin{aligned} t_5t_1 &= (1, 4, 2, 3), \\ t_4t_2t_3t_1t_4t_2t_3t_1 &= (1, 4, 2, 3), \\ t_5t_2t_3t_4t_1 &= (1, 3, 5, 4, 2). \end{aligned}$$

We use our technique of double coset enumeration to show that

$$|G| = \left| \frac{2^{*5} : (5 : 4)}{[x^{-2} * y^{-2} * t^{x^3}]^4, [y^{-1} * x^{-1} * t]^8, [x^2 * t]^5} \right| \leq 320$$

. In order to obtain the index of N in G we shall perform a manual double coset enumeration of G over N ; thus we must find all double cosets $[w] = NwN$ and work out how many single cosets each of them contains. We shall know that we have completed the double coset enumeration when the set of right cosets obtained is closed under right multiplication. Moreover, the completion test above is best performed by obtaining the orbits of $N^{(w)}$ on the symmetric generators. We need only identify, for each $[w]$, the double coset to which the right coset Nwt_i belongs for one symmetric generator t_i from each orbit.

Word of length 0

- NeN is denoted by $[*]$.

$NeN = \{N\}$. The number of right cosets in $[*]$ is equal to $\frac{|N|}{|N|} = \frac{20}{20} = 1$. Since N is transitive on $\{1, 2, 3, 4, 5\}$, the orbit of N on $\{1, 2, 3, 4, 5\}$ is $\{1, 2, 3, 4, 5\}$.

Word of length 1

- Nt_1N is denoted by [1]

$N^1 = \langle (2, 4, 3, 5) \rangle = N^{(1)}$. The number of right cosets in [1] is equal to $\frac{|N|}{|N^{(1)}|} = \frac{20}{4} = 5$. the orbits of $N^{(1)}$ on $\{1, 2, 3, 4, 5\}$ are $\{1\}$, and $\{2, 4, 5, 3\}$. We pick a representative, say t_i from each orbit and determine the double cosets that contains Nt_i .

$$Nt_1t_1 \in [*] \text{ (1 goes back to the double coset [*]), since } t_1^2 = e.$$

Thus, t_1 takes [1] to [*].

Word of length 2

- Nt_1t_2N is denoted by [12].

We note that $N^{(1,2)} \geq N^{12} = 1$. Now $t_1t_2 = t_2t_1$. The number of right cosets in [12] is to $\frac{|N|}{|N^{(12)}|} = \frac{20}{2} = 10$. The orbits of $N^{(12)}$ on $\{1, 2, 3, 4, 5\}$ are $\{5\}$, $\{1, 2\}$, and $\{3, 4\}$.

$$Nt_1t_2 \in [12] \text{ (2 goes to the double coset [12])}.$$

We now take the representative 2 of the orbit $\{1, 2\}$. and determine that $Nt_1t_2t_2 = Nt_1 \in [1]$. So 2 t_i 's take [12] to [1]. Take the representative 3 of the orbit $\{3, 4\}$ give a reason why $Nt_1t_2t_3 = Nt_1t_2$, $Nt_1t_2t_5 = Nt_1t_2$ and determine that $Nt_1t_2t_3 = Nt_1t_2 \in [12]$. And take the representative 5 of the orbit $\{5\}$ and determine that $Nt_1t_2t_5 = Nt_1t_2 \in [12]$.

Since the set of right cosets are closed under right multiplication by t_i 's where $i = 1, 2, 3, 4, 5$, we must have completed the double coset enumeration of G over N . We summarize the information in the following diagram we now compute the order of G .

Now

$$|G| = \left| \frac{2^{*5}:(5:4)}{[x^{-2}*y^{-2}*t^3]^4, [y^{-1}*x^{-1}*t]^8, [x^2*t]^5} \right|,$$

$$|G| \leq \left(\frac{|N|}{|N|} + \frac{|N|}{|N^{(1)}|} + \frac{|N|}{|N^{(12)}|} \right) \times |N|$$

Thus,

$$\begin{aligned} \implies |G| &\leq (1 + 5 + 10) \times 20 \\ \implies |G| &\leq (16 \times 20) \\ \implies |G| &\leq 320 \end{aligned}$$

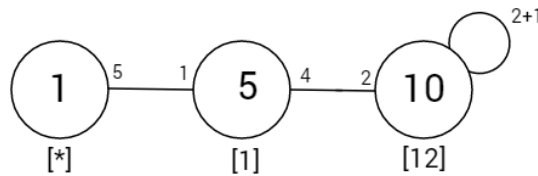

Figure 3.1: Cayley diagram of $2^4 : (5 : 4)$ over $(5:4)$

3.2 Proof of $G \cong 2^4 : (5 : 4)$

G_1 is the permutation representation of G on the 3 right cosets of $N = \langle x, y \rangle$ in G .

```
G<x,y,t>:=Group<x,y,t|x^5,y^4,y^-1*x^-2*y*x^-1,t^2,
(x^-2*y^-2*t^(x^3))^4,(y^-1*x^-1*t)^8,(x^2*t)^5>;
#G
f,G1,k:=CosetAction(G,sub<G|x,y>);
```

The following composition factors and the normal lattice suggest that $NL[2]$ is an abelian normal subgroup of G_1 .

```
CompositionFactors(G1);
G
| Cyclic(2)
*
| Cyclic(2)
*
| Cyclic(5)
*
| Cyclic(2)
*
```

```

      | Cyclic(2)
      *
      | Cyclic(2)
      *
      | Cyclic(2)
      1

NL:=NormalLattice(G1);
NL;
Normal subgroup lattice
-----

[5] Order 320 Length 1 Maximal Subgroups: 4
---
[4] Order 160 Length 1 Maximal Subgroups: 3
---
[3] Order 80 Length 1 Maximal Subgroups: 2
---
[2] Order 16 Length 1 Maximal Subgroups: 1
---
[1] Order 1 Length 1 Maximal Subgroups:

IsIsomorphic(NL[2],X);
true

Now NL[2] = 2^4. A presentation of 2^4 is
2^4={a,b,c,d,e,f|a^2,b^2,c^2,d^2,e^5,f^4,e^f = e^2,(a,b),
(a,c),(a,d),(b,c),(b,d),(c,d)}.

X:=AbelianGroup(GrpPerm,[2,2,2,2]);
IsIsomorphic(NL[2],X);
true

The quotient group q = G1/NL[2]
is the group
(5:4) with presentation
q = {H<a,b,c,d,e,f>:=Group<a,b,c,d,e,f|a^2,b^2,c^2,
d^2,(a,b),(a,c),(a,d),(b,c),(b,d),(c,d),e^5,f^4,e^f=e^2,
a^e=b,a^f=a*c , b^e=c , b^f=a*b*d , c^e=d , c^f=a*c*d ,
d^e=a*b*c*d ,d^f=b*d>;}.
q,ff:=quo <G1|NL[2]>;
q;
Permutation group q acting on a set of cardinality 5
Order = 20 = 2^2 * 5

```

```
(1, 2, 3, 4, 5)
(2, 3, 5, 4)
Id(q)
```

```
IsIsomorphic(G1,h1);
true
```

Thus G_1 is a semi-direct product of 2^4 by $(5:4)$.
 The action of $(5:4)$ on 2^4 is $a^c = a^6 * b, a^d = a^6,$
 $a^e = a^2 * b^6, b^c = b, b^d = b^6, b^e = a^3 * b^5.$

Hence, a presentation of $2^4:(5:4)$ is given by $\{q = \{H \langle a, b, c, d, e, f \rangle := \text{Group} \langle a, b, c, d, e, f \mid a^2, b^2, c^2, d^2, (a, b), (a, c), (a, d), (b, c), (b, d), (c, d), e^5, f^4, e^f = e^2, a^e = b, a^f = a * c, b^e = c, b^f = a * b * d, c^e = d, c^f = a * c * d, d^e = a * b * c * d, d^f = b * d \rangle; \}$.

We finally verify that $G_1 = 2^4:(5:4)$.

```
T:=Transversal(G1,NL[2]);
ff(T[2]) eq q.1;
true
```

```
ff(T[3]) eq q.2;
true
```

```
for i,j,k,l in [0..2] do
if A^T[3] eq A^i*B^j*C^k*D^l then
i,j,k,l; end if; end for;
1 0 1 0
1 0 1 2
1 2 1 0
1 2 1 2
```

```
for i,j,k,l in [0..2] do if B^T[2]
eq A^i*B^j*C^k*D^l then
i,j,k,l; end if; end for;
0 0 1 0
0 0 1 2
0 2 1 0
0 2 1 2
2 0 1 0
2 0 1 2
2 2 1 0
2 2 1 2
```

```

for i,j,k,l in [0..2] do if B^T[3]
eq A^i*B^j*C^k*D^l then
i,j,k,l; end if; end for;
1 1 0 1
1 1 2 1

```

```

for i,j,k,l in [0..2] do if C^T[2]
eq A^i*B^j*C^k*D^l then
i,j,k,l; end if; end for;
0 0 0 1
0 0 2 1
0 2 0 1
0 2 2 1
2 0 0 1
2 0 2 1
2 2 0 1
2 2 2 1

```

```

for i,j,k,l in [0..2] do if C^T[3]
eq A^i*B^j*C^k*D^l then
i,j,k,l; end if; end for;
1 0 1 1
1 2 1 1

```

```

for i,j,k,l in [0..2] do if D^T[2]
eq A^i*B^j*C^k*D^l then
i,j,k,l; end if; end for;
1 1 1 1

```

```

for i,j,k,l in [0..2] do if D^T[3]
eq A^i*B^j*C^k*D^l then
i,j,k,l; end if; end for;
0 1 0 1
0 1 2 1
2 1 0 1
2 1 2 1

```

```

H<a,b,c,d,e,f>:=Group<a,b,c,d,e,f|a^2,b^2,c^2,d^2,
(a,b),(a,c),(a,d),(b,c),(b,d),(c,d),e^5,f^4,
e^f=e^2,a^e=b, a^f=a*c, b^e=c, b^f=a*b*d,
c^e=d, c^f=a*c*d, d^e=a*b*c*d, d^f=b*d>;
#H;
320

```

```
f1,h1,k1:=CosetAction(H,sub<H|Id(H)>);
IsIsomorphic(G1,h1);
true
```

3.3 Magma Work for $2^{*5} : (5 : 4)$

```
S:=Sym(5);
xx:=S!(1,2,4,5,3);
yy:=S!(2,4,3,5);
N:=sub<S|xx,yy>;
Stabiliser(N,1);
#N;
G<x,y,t>:= Group<x,y,t|x^5,y^4,y^{-1}*x^{-2}*y*x^{-1},t^2,
(t,y),(x^{-2}*y^{-2}*t^{x^3})^4,(y^{-1}*x^{-1}*t)^8,
(x^2*t)^5>
f,G1,k:=CosetAction(G,sub<G|x,y>);
IN:=sub<G1|f(x),f(y)>;
CompositionFactors(G1);
#DoubleCosets(G,sub<G|x,y>,sub<G|x,y>);
DoubleCosets(G,sub<G|x,y>,sub<G|x,y>);
NN<a,b>:= Group<a,b|a^5,b^4,b^{-1}*a^{-2}*b*a^{-1}>;
Sch:= SchreierSystem(NN,sub<NN|Id(NN)>);
ArrayP:=[Id(N): i in [1 .. 20]];
for i in [2 .. 20] do
P :=[Id(N): l in [1 .. #Sch[i]]];
for j in [1..#Sch[i]] do
if Eltseq(Sch[i])[j] eq 1 then P[j]:=xx; end if;
if Eltseq(Sch[i])[j] eq -1 then P[j]:=xx^{-1}; end if;
if Eltseq(Sch[i])[j] eq 2 then P[j]:=yy; end if;
if Eltseq(Sch[i])[j] eq -2 then P[j]:=yy^{-1}; end if;
end for;
PP:=Id(N);
for k in [1 .. #P] do
PP:=PP*P[k]; end for;
ArrayP[i]:=PP;
end for;
for i in [1 .. 20] do if ArrayP[i] eq N!(2,4,3,5)
then Sch[i];
end if; end for;
prodim := function(pt, Q, I)
Return the image of pt under permutations Q[i]
```

applied sequentially.

```
v:=pt;
for i in I do
v:=v^{Q[i]};
end for;
return v;
end function;
ts := [ Id(G1): i in [1 .. 5] ];
ts[1]:=f(t); ts[2]:=f(t^x); ts[3]:=f(t^{x^4});
ts[4]:=f(t^{x^2}); ts[5]:=f(t^{x^3});
```

<This cst function will keep track of all single cosets>

```
cst:= [null : i in [1 .. Index(G,sub<G|x,y>)]]
where null is [Integers()];
for i := 1 to 5 do
cst[prodim(1, ts, [i])]:= [i];
end for;
m:=0; for i in [1 .. 16] do if cst[i] ne []
then m:=m+1; end if; end for; m;
```

```
N1:=Stabiliser(N, [1]);
S:={ [1] };
SS:=S^{N};
SS;
#SS;
SSS:=Setseq(SS);
SSS;
for i in [1 .. #SS] do
for g in IN do
if ts[1] eq
g*ts[Rep(SSS[i])[1]]
then print SSS[i];
end if; end for; end for;
N1s:=N1;
#N1s;
T1:=Transversal(N,N1s);
#T1;
for i := 1 to #T1 do
SS:= [1]^{T1[i]}
cst[prodim(1, ts, SS)] := SS;
end for;
m:=0;
for i in [1 .. 16] do if cst[i] ne []
```

```

then m:=m+1; end if; end for; m;
Orbits(N1s);
#N1s;

N12:=Stabiliser(N, [1,2]);
S:={ [1,2] };
SS:=S^{N};
SS;
#SS;
SSS:=Setseq(SS);
SSS;
for i in [1 .. #SS] do
for g in IN do if ts[1]*ts[2] eq
g*ts[Rep(SSS[i])[1]]*ts[Rep(SSS[i])[2]]
then print SSS[i];
end if; end for; end for;
N12s:=N12;
#N12s;
T12:=Transversal(N,N12s);
#T12;
for i := 1 to #T12 do
SS:= [1,2]^{T12[i]};
cst[prodim(1, ts, SS)] := SS;
end for;
m:=0;
for i in [1 .. 16] do if cst[i] ne []
then m:=m+1;
end if; end for; m;
Orbits(N12s);
for m,n in IN do if ts[1]*ts[2] eq m*(ts[1])^{n}
then m,n; end if; end for;

N123:=Stabiliser(N, [1,2,3]);
S:={ [1,2,3] };
SS:=$S^{N}$;
SSS:=Setseq(SS);
for i in [1 .. #SS] do
for g in IN do if ts[1]*ts[2]*ts[3] eq
g*ts[Rep(SSS[i])[1]]*ts[Rep(SSS[i])[2]]*ts[Rep(SSS[i])[3]]
then print SSS[i];
end if; end for; end for;
N123s:=N123;
for g in N do if 1^{g} eq 1 and 2^{g} eq 3 and 3^{g} eq 2
then N123s:=sub<N|N123s,g>; end if; end for;

```



```

#N123s;
T123:=Transversal(N,N123s);
#T123;
for i := 1 to #T123 do
SS:= [1,2,3]^{T123[i]};
cst[prodim(1, ts, SS)] := SS;
end for;
m:=0;\
for i in [1 .. 16] do if cst[i] ne []
then m:=m+1; end if; end for; m;
Orbits(N123s);
for m,n in IN do if ts[1]*ts[2]*ts[3] eq m*(ts[1]*ts[2])^{n}
then m,n; end if; end for;

N125:=Stabiliser(N,[1,2,5]);
S:={1,2,5};
SS:=S^{N};
SSS:=Setseq(SS);
for i in [1..#SS] do
for g in IN do if ts[1]*ts[2]*ts[5] eq
g*ts[Rep(SSS[i])[1]]*ts[Rep(SSS[i])[2]]*ts[Rep(SSS[i])[3]]
then print SSS[i];
end if; end for; end for;
N125s:=N125;
# N125s;
T125:=Transversal(N,N125s);
#T125;
for i := 1 to #T125 do
SS := [1,2,5]^{T125[i]};
cst[prodim(1, ts, SS)] := SS;
end for;
m:=0;
for i in [1 .. 16] do if cst[i] ne [] then m:=m+1;
end if; end for; m;
Orbits(N125s);

/* To print all single cosets */
for i in [1 .. 10] do i, cst[i]; end for;

```

Chapter 4

Construction of

$$(10 \times 10) : ((3 \times 4) : 2)$$

4.1 Double Coset Enumeration of $(10 \times 10) : ((3 \times 4) : 2)$

The group $G = \langle x, y, t | y^4, y^{-1} * x^{-2} * y * x^{-1}, t^2, (t, y) \rangle$ factored by $[y^{-1} * x^{-1} * t]^4$,

where $G = (15 : 4) = \langle x, y \rangle$ with $x \sim (1, 2, 6, 3, 8, 14, 10, 7, 12,$
 $11, 15, 13, 5, 9, 4),$

$y \sim (2, 7, 8, 9)(3, 10, 5, 11)(4, 12, 13, 6),$

and let $t \sim t_1$.

$$\begin{aligned} \text{Now } (y^{-1} * x^{-1} * t)^4 &= e \\ \implies y^{-1}x^{-1}t_1y^{-1}x^{-1}t_1y^{-2}t^{-2}t_4t_1 &= e \implies y^{-1}x^{-1}t_1y^{-3}x^{-3}t_2t_4t_1 = e \\ \implies y^{-4}x^{-4}t_5t_2t_4t_1 &= e \end{aligned}$$

So $y^{-4}x^{-4}t_5t_2t_4 = t_1$. We also have $Nt_5t_2t_4 = Nt_1$ Thus,

$$t_5t_2t_4t_1 = (1, 15, 14)(2, 13, 10)(3, 9, 12)(4, 11, 8)(5, 7, 6), \dots$$

We use our technique of double coset enumeration to show that $|G| = \left| \frac{2^{*15} : (15 \times 4)}{[y^{-1} * x^{-1} * t]^4} \right| \leq 2400..$

In order to obtain the index of N in G we shall perform a manual double coset

enumeration of G over N ; thus we must find all double cosets $[w] = NwN$ and work out how many single cosets each of them contains. We shall know that we have completed the double coset enumeration when the set of right cosets obtained is closed under right multiplication. Moreover, the completion test above is best performed by obtaining the orbits of $N^{(w)}$ on the symmetric generators. We need only identify, for each $[w]$, the double coset to which the right coset Nwt_i belongs for one symmetric generator t_i from each orbit.

Word of length 0

- NeN is denoted by $[*]$.

$NeN = \{N\}$. The number of right cosets in $[*]$ is equal to $\frac{|N|}{|N|} = \frac{60}{60} = 1$. Since N is transitive on $\{1, 2, 3, 4, 5, 6, 7, 8, 9, 10, 11, 12, 13, 14, 15\}$, the orbit of N on $\{1, 2, 3, 4, 5, 6, 7, 8, 9, 10, 11, 12, 13, 14, 15\}$ is $\{1, 2, 3, 4, 5, 6, 7, 8, 9, 10, 11, 12, 13, 14, 15\}$.

Word of length 1

- Nt_1N is denoted by $[1]$

$$N^1 = \langle (2, 7, 8, 9)(3, 10, 5, 11)(4, 12, 13, 6) \rangle = N^{(1)}.$$

The number of right cosets in $[1]$ is equal to $\frac{|N|}{|N^{(1)}|} = \frac{60}{4} = 15$.

The orbits of $N^{(1)}$ on $\{1, 2, 3, 4, 5, 6, 7, 8, 9, 10, 11, 12, 13, 14, 15\}$ are $\{1\}$, $\{14\}$, $\{15\}$, $\{2, 7, 8, 9\}$, $\{3, 10, 5, 11\}$, and $\{4, 12, 13, 6\}$.

We pick a representative, say t_i from each orbit

and determine the double cosets that contains Nt_i .

$$Nt_1t_1 \in [*] \text{ (1 goes back to the double coset [*]), since } t_1^2 = e.$$

Word of length 2

- $Nt_1t_{14}N$ is denoted by [114].

We note that $N^{(1,14)} \geq N^{114} = 1$.

Now $t_1t_{14} = t_3t_{12}, t_1t_{14} = t_{10}t_{13}, t_1t_{14} = t_{11}t_4$ and $t_1t_{14} = t_5t_6$.

The number of right cosets in [114] is equal to $\frac{|N|}{|N^{(114)}|} = \frac{60}{20} = 3$.

The orbits of $N^{(13)}$ on $\{1, 2, 3, 4, 5, 6, 7, 8, 9, 10, 11, 12, 13, 14, 15\}$ are $\{1, 3, 10, 11, 5\}, \{2, 7, 8, 15, 9\}$ and $\{4, 12, 6, 13, 14\}$.

We now take the representative 14 of the orbit

$\{1, 2, 3, 4, 5, 6, 7, 8, 9, 10, 11, 12, 13, 14, 15\}$.

and determine that $Nt_1t_{14}t_{14} = Nt_1 \in [1]$.

So five of the fifteen t'_i s take [114] to [1].

- Nt_1t_5N is denoted by [15].

We have $N^{(15)} \geq N^{15} = 1$ show the generators of $N^{(15)}$.

Now $N^{(15)} \geq \langle t_1t_5 = t_3t_9, t_1t_5 = t_{10}t_2, t_1t_5 = t_{11}t_8, t_1t_5 = t_5t_7 \rangle$

The number of right cosets in [15] is equal to $\frac{|N|}{|N^{(15)}|} = \frac{60}{20} = 3$.

The orbit of $N^{(15)}$ on $\{1, 2, 3, 4, 5, 6, 7, 8, 9, 10, 11, 12, 13, 14, 15\}$ is $\{1, 3, 10, 11, 5\}, \{2, 7, 8, 15, 9\}$ and $\{4, 12, 6, 13, 14\}$ show $N^{(15)}$ generators.

We now take the representative 2 of the orbit

$\{1, 2, 3, 4, 5, 6, 7, 8, 9, 10, 11, 12, 13, 14, 15\}$

and determine that $Nt_1t_2t_2 = Nt_1 \in [1]$.

So five of the fifteen t'_i s take [15] to [1].

- Nt_1t_3N is denoted by [13]

We have $N^{(13)} \geq N^{13} = 1$.

Now $t_1t_3 = t_2t_8, t_1t_3 = t_6t_{14}, t_1t_3 = t_3t_{10}, t_1t_3 = t_8t_7,$

$t_1t_3 = t_{14}t_{12}, t_1t_3 = t_9t_2, t_1t_3 = t_7t_{15}, t_1t_3 = t_{10}t_{11}, t_1t_3 = t_4t_6, t_1t_3 = t_{12}t_{13},$

$t_1t_3 = t_{13}t_4, t_1t_3 = t_{11}t_5, t_1t_3 = t_5t_1$ and $t_1t_3 = t_{15}t_9,$

We now take the representative 3 of the orbit

$\{1, 2, 3, 4, 5, 6, 7, 8, 9, 10, 11, 12, 13, 14, 15\}$

and determine that $Nt_1t_3t_3 = Nt_1 \in [1]$.

So one of the fifteen t'_i s take [13] to [1].

The number of right cosets in $[13]$ is equal to $\frac{|N|}{|N^{(13)}|} = \frac{60}{1} = 60$.

The orbit of $N^{(13)}$ on $\{1, 2, 3, 4, 5, 6, 7,$

$8, 9, 10, 11, 12, 13, 14, 15\}$ is $\{1\}, \{2\},$

$\{3\}, \{4\}, \{5\}, \{6\}, \{7\}, \{8\},$

$\{9\}, \{10\}, \{11\}, \{12\}, \{13\}, \{14\}$

and $\{15\}$.

Word of length 3

- $Nt_1t_{14}t_1N$ is denoted by $[1141]$.

We note that $N^{(1,14,1)} \geq N^{1141} = 1$. Now $t_1t_{14} = t_{14}t_{15}, t_1t_{14} = t_{15}t_1$.

The number of right cosets in $[1141]$ is equal to

$\frac{|N|}{|N^{(1141)}|} = \frac{60}{12} = 5$ show $N^{(141)}$ generators.

The orbits of $N^{(1141)}$ on

$\{1, 2, 3, 4, 5, 6, 7, 8, 9, 10, 11, 12, 13, 14, 15\}$ are $\{1, 14, 15\},$

$\{2, 7, 11, 3, 5, 10, 12, 13, 4, 6, 8, 9\}$.

We now take the representative 1 of the orbit

$\{1, 2, 3, 4, 5, 6, 7, 8, 9, 10, 11, 12, 13, 14, 15\}$. and determine that

$Nt_1t_{14}t_1t_1 = Nt_1t_{14} \in [114]$. So three of the fifteen t_i 's take $[1141]$ to $[114]$.

Now, we can construct the Cayley diagram. Since the set

of right cosets are closed under right multiplication by t_i^s

where $i = 1, 2, 3, 4, 5, 6, 7, 8, 9, 10, 11, 12, 13, 14, 15,$

we can determine the index of N in G . We conclude that

$$\begin{aligned} |G| &= \left| \frac{2^{*15}:(15:4)}{[y^{-1}*x^{-1}*t]^4} \right| \\ \implies |G| &\leq \left(\frac{|N|}{|N|} + \frac{|N|}{|N^{(1)}|} + \frac{|N|}{|N^{(114)}|} + \frac{|N|}{|N^{(12)}|} + \frac{|N|}{|N^{(13)}|} + \frac{|N|}{|N^{(1141)}|} \right) \times |N| \end{aligned}$$

$$\implies |G| \leq (1 + 15 + 3 + 60 + 60 + 5) \times 60$$

$$\implies |G| \leq (144 \times 60)$$

$$\implies |G| \leq 2400$$

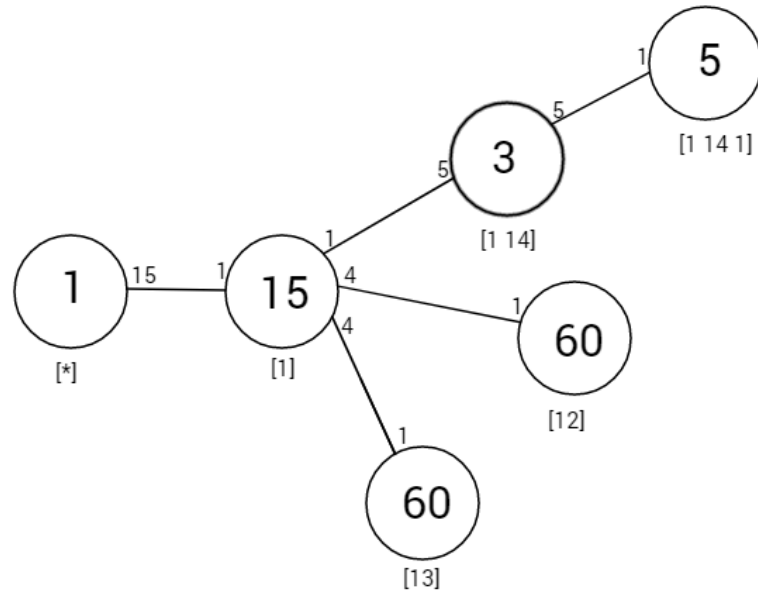

Figure 4.1: Cayley diagram of $(10 \times 10) : ((3 \times 4) : 2)$ over $(15 : 4)$

4.2 Proof of $G \cong (10 \times 10) : ((3 \times 4) : 2)$

```
G<x,y,t>:=Group<x,y,t|y^4,y^-1*x^-2*y*x^-1,t^2,(t,y),
(y^-1*x^-1*t)^4>;
```

```
#G;
2400
```

```
f,G1,k:=CosetAction(G,sub<G|x,y>);
```

```
NL:=NormalLattice(G1);
```

```
NL;
```

```
Normal subgroup lattice
```

```
-----
```

```
[25] Order 2400 Length 1 Maximal Subgroups: 22 23 24
```

```
---
```

```
[24] Order 1200 Length 1 Maximal Subgroups: 21
```

```
[23] Order 1200 Length 1 Maximal Subgroups: 19 20 21
```

```
[22] Order 1200 Length 1 Maximal Subgroups: 18 21
```

```
---
```

```
[21] Order 600 Length 1 Maximal Subgroups: 16 17
```

```
[20] Order 600 Length 1 Maximal Subgroups: 15 17
```

```
[19] Order 600 Length 1 Maximal Subgroups: 14 17
```

```

[18] Order 400      Length 1  Maximal Subgroups: 13 16
---
[17] Order 300      Length 1  Maximal Subgroups: 10 11 12
[16] Order 200      Length 1  Maximal Subgroups: 9 12
[15] Order 120      Length 1  Maximal Subgroups: 10
[14] Order 120      Length 1  Maximal Subgroups: 11
---
[13] Order 100      Length 1  Maximal Subgroups: 9
[12] Order 100      Length 1  Maximal Subgroups: 5 7 8
[11] Order 60       Length 1  Maximal Subgroups: 6 8
[10] Order 60       Length 1  Maximal Subgroups: 6 7
---
[ 9] Order 50       Length 1  Maximal Subgroups: 5
[ 8] Order 20       Length 1  Maximal Subgroups: 2 4
[ 7] Order 20       Length 1  Maximal Subgroups: 3 4
[ 6] Order 12       Length 1  Maximal Subgroups: 4
---
[ 5] Order 25       Length 1  Maximal Subgroups: 2 3
[ 4] Order 4        Length 1  Maximal Subgroups: 1
---
[ 3] Order 5        Length 1  Maximal Subgroups: 1
[ 2] Order 5        Length 1  Maximal Subgroups: 1
---
[ 1] Order 1        Length 1  Maximal Subgroups:

```

```

/* The largest abelian subgroup of G1 is NL[12].*/
for i in [1..25] do if IsAbelian(NL[i]) then i;
end if; end for;
1
2
3
4
5
7
8
12

```

We factor G1 by NL[12].

```

q,ff:=quo<G1|NL[12]>;
q;
Permutation group q acting on a set of cardinality 12
Order = 24 = 2^3 * 3
      (1, 2, 4) (3, 5, 7) (6, 8, 10) (9, 11, 12)

```

```
(1, 3, 6, 9)(2, 5, 8, 11)(4, 7, 10, 12)
(2, 4)(5, 7)(8, 10)(11, 12)
```

Thus G_1 is a mixed extension of $NL[12]$ by q .

```
/* Isomorphism Type of NL[12]:*/
```

```
X:=AbelianGroup(GrpPerm,[10,10]);
IsIsomorphic(NL[12],X);
true
```

```
A:=G1!(1, 24, 25, 15, 29, 36, 33, 19, 32, 7)(2, 28)(3, 30)
(4, 21)(5, 20)(6, 35)(8,39)(9, 11)(10, 31, 12, 18, 37, 23,
22, 26, 17, 40)(13, 16)(14, 34)(27, 38);
B:=G1!(1, 22, 29, 10, 32, 37, 25, 17, 33, 12)(2, 6, 21, 3,
11, 27, 20, 14, 16, 8)(4,30, 9, 38, 5, 34, 13, 39, 28, 35)
(7, 23, 15, 40, 19, 18, 24, 26, 36, 31);
NL[12] eq sub<G1|A,B>;
true
```

```
IsIsomorphic(NL[12],DirectProduct(CyclicGroup(10),
CyclicGroup(10)));
```

\noindent Thus, $NL[12]$ is isomorphic to 10×10
(direct product of two cyclic groups of order 10).

```
/* Isomorphism Type of q:*/
```

```
q;
Permutation group q acting on a set of cardinality 12
Order = 24 = 2^3 * 3
```

```
(1, 2, 4)(3, 5, 7)(6, 8, 10)(9, 11, 12)
(1, 3, 6, 9)(2, 5, 8, 11)(4, 7, 10, 12)
(2, 4)(5, 7)(8, 10)(11, 12)
```

```
/* The generators of q are q1,q2,q3. */
q1:=q!(1, 2, 4)(3, 5, 7)(6, 8, 10)(9, 11, 12);
q2:=q!(1, 3, 6, 9)(2, 5, 8, 11)(4, 7, 10, 12);
q3:=q!(2, 4)(5, 7)(8, 10)(11, 12);
nl:=NormalLattice(q);
nl;
Normal subgroup lattice
-----
```

```
[11] Order 24 Length 1 Maximal Subgroups: 8 9 10
```



```

----
[10] Order 12 Length 1 Maximal Subgroups: 6
[ 9] Order 12 Length 1 Maximal Subgroups: 4 6
[ 8] Order 12 Length 1 Maximal Subgroups: 5 6 7
----
[ 7] Order 6 Length 1 Maximal Subgroups: 3
[ 6] Order 6 Length 1 Maximal Subgroups: 2 3
[ 5] Order 6 Length 1 Maximal Subgroups: 3
[ 4] Order 4 Length 1 Maximal Subgroups: 2
----
[ 3] Order 3 Length 1 Maximal Subgroups: 1
[ 2] Order 2 Length 1 Maximal Subgroups: 1
----
[ 1] Order 1 Length 1 Maximal Subgroups:

/* The largest abelian subgroup of q is nl[9] of order 12.*/
IsAbelian(nl[9]);
true

/* Thus, q is a semi-direct product of 3x4 by 2. */
/* A presentation for q is given by */
FPGGroup(q);
Finitely presented group on 3 generators
Relations
  a^3 = 1, b^4 = 1, c^2 = 1, (a, b) = 1, (a^-1 * c)^2 = 1,
  b^-1 * c * b * c = 1

Q<a,b,c>:=Group<a,b,c|a^3 = 1,b^4 , c^2 , (a, b) , (a^-1 * c)^2 ,
b^-1 * c * b * c >.

T:=Transversal(G1,NL[12]);
ff(T[2]) eq q1; ff(T[3]) eq q2; ff(T[4]) eq q3;
D:=T[2]; E:=T[3]; F:=T[4];

/* Action of q=<a,b,c> on NL[12]=<A,B> */
D:=T[2]; E:=T[3]; F:=T[4];
for i,j in [1..10] do if A^D eq A^i*B^j then i,j;
end if; end for;
6 5
*d^a=d^6*e^5

for i,j in [1..10] do if A^E eq A^i*B^j then i,j;
end if; end for;
7 10

```

```

d^b=d^7*e^10

for i,j in [1..10] do if A^F eq A^i*B^j then i,j;
end if; end for;
6 7
d^c=d^6*e^7

for i,j in [1..10] do if B^D eq A^i*B^j then i,j;
end if; end for;
5 1

e^a=d^5*e
for i,j in [1..10] do if B^E eq A^i*B^j then i,j;
end if; end for;
10 7

e^b=d^10*e^7
for i,j in [1..10] do if B^F eq A^i*B^j then i,j;
end if; end for;
5 4

e^c=d^5*e^4
d^a=d^6*e^5,d^b=d^7*e^10,d^c=d^6*e^7,e^a=d^5*e,e^b=d^10*e^7,
e^c=d^5*e^4

/* Writing Elements of q=<q1=a,q2=b, q3=c> in terms of
NL[12]=<A=d,B=e> */
T:=Transversal(G1,NL[12]);
ff(T[2]) eq q.1;
true

ff(T[3]) eq q.2;
true

ff(T[4]) eq q.3;
true

Order(T[2]), Order(T[3]), Order(T[4]);
15 4 2

for i in [1..14] do if T[2]^i in NL[12] then i;
end if; end for;
3
6

```

9
12

```
for i,j in [1..10] do if T[2]^3 eq A^i*B^j then i,j;
end if; end for;
2 4
```

```
for i,j in [1..10] do if (T[2],T[3]) eq A^i*B^j then i,j;
end if; end for;
4 8
```

```
(2, 16, 20, 11, 21) (3, 6, 8, 14, 27) (4, 28, 13, 5, 9)
(30, 35, 39, 34, 38)
(T[2]^-1 * T[4])^2;
(1, 10, 25, 12, 29, 37, 33, 22, 32, 17) (2, 14, 11, 6, 16,
27, 21, 8, 20, 3) (4, 39, 5, 30, 28, 34, 9, 35, 13, 38) (7, 40,
24, 31, 15, 18, 36, 23, 19, 26)
```

```
for i,j in [1..10] do if (T[2]^-1*T[4])^2 eq A^i*B^j then
i,j; end if; end for;
2 7
```

```
H<d,e,a,b,c>:=Group<d,e,a,b,c|d^10,e^10,(d,e),a^3 =d^2*e^4,b^4 ,
c^2 ,(a,b)=d^4*e^8,(a^-1 * c)^2=d^2*e^7,b^-1 * c * b * c,
d^a=d^6*e^5,d^b=d^7*e^10,d^c=d^6*e^7,e^a=d^5*e,e^b=d^10*e^7,
e^c=d^5*e^4>;
#H;
2400
```

The following Magma segment shows that G_1 is isomorphic to the mixed extension of the abelian subgroup (10×10) by the subgroup $(3 \times 4):2$

```
H<d,e,a,b,c>:=Group<d,e,a,b,c|d^10,e^10,(d,e),a^3 =d^2*e^4,b^4 ,
c^2 ,(a,b)=d^4*e^8,(a^-1 * c)^2=d^2*e^7,b^-1 * c * b * c,
d^a=d^6*e^5,d^b=d^7*e^10,d^c=d^6*e^7,e^a=d^5*e,e^b=d^10*e^7,
e^c=d^5*e^4>;
h,H1,k1:=CosetAction(H,sub<H|Id(H)>);
IsIsomorphic(G1,H1);
true
```

Chapter 5

Construction of $PGL(2, 7)$

5.1 Double Coset Enumeration of $PGL(2, 7)$

We start with the group G with symmetric presentations the group

$$G = \langle x, y, t \mid y^2, (x^{-1} * y)^2, x^4, t^2, (t, y * x^2) \rangle$$

factored by $[x^4 * t]^3$, $[x^3 * t]^3$, and $[x^5 * t]^4$,

where $G = D_{14} = \langle x, y \rangle$ with $x \sim (1, 2, 3, 4, 5, 6, 7, 8, 9, 10, 11, 12, 13, 14)$,

$y \sim (1, 13)(2, 12)(3, 11)(4, 10)(5, 9)(6, 8)$.

$N = \langle x, y \rangle \cong D_{14}$, and we note that $G \cong PGL(2, 7)$.

However, we note that our relations force $\text{sub} \langle G \mid x, y \rangle \cong D_7$.

Thus, we replace $x \sim (1, 2, 5, 7, 6, 3, 4)$, and $y \sim (1, 3)(2, 6)(5, 7)$

as follows:

```
> H<a, b>:=Group<a, b|b^2, (a^-1*b)^2, a^7>;
```

```
> #H;
```

```
14
```

```
> ff, H1, kk:=CosetAction(H, sub<H|Id(H)>);
```

```
> H1;
```

```
Permutation group H1 acting on a set of cardinality 14
```

```
(1, 2, 5, 9, 12, 8, 4)(3, 7, 11, 14, 13, 10, 6)
```

```
(1, 3)(2, 6)(4, 7)(5, 10)(8, 11)(9, 13)(12, 14)
```

```
> ff, H1, kk:=CosetAction(H, sub<H|b*a^2>);
```

```
> H1;
```

```
Permutation group H1 acting on a set of cardinality 7
```

```
Order = 14 = 2 * 7
```

```
(1, 2, 5, 7, 6, 3, 4)
```

```

(1, 3) (2, 6) (5, 7)
> Stabiliser(H1,1);
Permutation group acting on a set of cardinality 7
Order = 2
(2, 4) (3, 5) (6, 7)
> ff(b*a^2);
(2, 4) (3, 5) (6, 7)

```

$$\begin{aligned}
& \text{Now } (x^4 t_1)^3 = e \\
& \implies x^4 t_1 x^4 t_1 x^4 t_1 = e \\
& \implies x^4 t_1 x^4 x^4 t_1 x^{-4} t_1 x^4 t_1 = e \\
& \implies x^4 t_1 x^8 t_1 (x^4) t_1 = e \\
& \implies x^{12} t_2 t_6 t_1 = e
\end{aligned}$$

So $x^1 2 t_2 t_6 = 1$. We also have $N t_2 t_6 = N t_1$.

$$\begin{aligned}
& (x^3 t_1)^3 = e \\
& \implies x^3 t_1 x^3 t_1 x^3 t_1 = e \\
& \implies x^3 t_1 x^3 x^3 x^{-3} t_1 x^3 t_1 = e \\
& \implies x^3 t_1 x^6 t_1 (x^3) t_1 = e. \\
& \implies x^9 t_4 t_7 t_1 = e.
\end{aligned}$$

So $x^9 t_4 t_7 = 1$. We also have $N t_4 t_7 = N t_1$.

$$\begin{aligned}
& \text{And, } (x^5 t_1)^4 = e \\
& \implies x^5 t_1 x^5 t_1 x^5 t_1 x^5 t_1 = e \\
& \implies x^5 t_1 x^5 t_1 x^5 x^5 x^{-5} t_1 x^5 t_1 = e \\
& \implies x^5 t_1 x^5 t_1 x^{10} t_1 (x^5) t_1. \\
& \implies x^5 t_1 x^{15} t_1 (x^{10}) t_1 (x^5) t_1 = e. \\
& \implies x^{20} t_2 t_7 t_3 t_1 = e. \\
& \implies x^{20} t_2 t_7 t_3 t_1 = e.
\end{aligned}$$

So $x^{20} t_2 t_7 t_3 = 1$. We also have $N t_2 t_7 t_3 = N t_1$.

Thus,

$$t_2 t_6 t_1 = (1, 5, 6, 4, 2, 7, 3),$$

$$t_4 t_7 t_1 = (1, 3, 7, 2, 4, 6, 5),$$

$$t_2 t_7 t_3 t_1 = (1, 2, 5, 7, 6, 3, 4), \dots$$

We use our technique of double coset enumeration to show that $|G| = \left| \frac{2^7 \cdot D_7}{[x^4 * t]^3, [x^3 * t]^3, [x^5 * t]^4} \right| \leq 336$. In order to obtain the index of N in G we shall perform a manual double coset enumeration of G over N ; thus we must find all double cosets $[w] = NwN$ and work out how many single cosets each of them contains. We shall know that we have completed the double coset enumeration when the set of right cosets obtained is closed under right multiplication. Moreover, the completion test above is best performed by obtaining the orbits of $N^{(w)}$ on the symmetric generators. We need only identify, for each $[w]$, the double coset to which the right coset Nwt_i belongs for one symmetric generator t_i from each orbit.

Word of length 0

- NeN is denoted by $[*]$.

$NeN = \{N\}$. The number of right cosets in $[*]$ is equal to $\frac{|N|}{|N|} = \frac{14}{14} = 1$. Since N is transitive on $\{1, 2, 3, 4, 5, 6, 7\}$, The orbit of N on $\{1, 2, 3, 4, 5, 6, 7\}$ is $\{1, 2, 3, 4, 5, 6, 7\}$.

Word of length 1

- Nt_1N is denoted by $[1]$

$$N^1 = \langle (2, 4)(3, 5)(6, 7) \rangle = N^{(1)}.$$

The number of right cosets in $[1]$ is equal to

$\frac{|N|}{|N^{(1)}|} = \frac{14}{2} = 7$. The orbits of $N^{(1)}$ on $\{1, 2, 3, 4, 5, 6, 7\}$ are $\{1\}$, $\{2, 4\}$, $\{3, 5\}$ and $\{6, 7\}$.

We pick a representative, say t_i from each orbit and determine the double cosets that contains Nt_i .

$Nt_1t_1 \in [*]$ (1 goes back to the double coset [*]), since $t_1^2 = e$.
 $Nt_1t_2 \in [1]$ (2 goes to the double coset [12])
 $Nt_1t_3 \in [1]$ (2 goes to the double coset [13])
 $Nt_1t_6 \in [1]$ (2 goes back to the double coset [1]), since $t_1 * t_6 = x^{-2} * t_2$.

Thus, t_1 takes [1] to [*], t_6 take [1] to itself. And t_2, t_3 takes to new double coset [12],[13] respectively.

Word of length 2

- Nt_1t_2N is denoted by [12].

We note that $N^{(1,2)} \geq N^{12} = 1$. Now $t_1t_2 = t_4t_3$
 $(1, 3, 5, 7, 9, 11, 13)(2, 4, 6, 8, 10, 12, 14) \in N^{(12)}$
 The number of right cosets in [12] is equal to $\frac{|N|}{|N^{(12)}|} = \frac{14}{2} = 7$.
 The orbits of $N^{(12)}$ on $\{1,2,3,4,5,6,7\}$ is
 $\{7\}, \{1, 4\}, \{2, 3\},$ and $\{5, 6\}$.
 We now take the representative 2 of the orbit
 $\{7\}, \{1, 4\}, \{2, 3\},$ and $\{5, 6\}$.
 and determine that $Nt_1t_2t_2 = Nt_1t_2 \in [12]$. So 2 of the seven t_i 's take [12] to [12] itself.

- Nt_1t_3N is denoted by [13].

We have $N^{(13)} \geq N^{13} = 1$.
 Now $t_1t_3 = t_2t_7$.
 The number of right cosets in [13] is equal to $\frac{|N|}{|N^{(13)}|} = \frac{14}{2} = 7$.
 The orbit of $N^{(13)}$ on $\{1, 2, 3, 4, 5, 6, 7\}$ is
 $\{6\}, \{1, 2\}, \{3, 7\},$ and $\{4, 5\}$. We now take the representative 3 of the orbit
 $\{6\}, \{1, 2\}, \{3, 7\},$ and $\{4, 5\}$
 and determine that $Nt_1t_3t_3 = Nt_1t_3 \in [13]$. So 2 of the seven t_i 's take [13] to [13].

- Nt_1t_6N is denoted by [16]

We have $N^{(16)} \geq N^{16} = 1$.

Now $t_1t_6 = t_2t_7$.

The number of right cosets in [16] is equal to $\frac{|N|}{|N^{(13)}|} = \frac{14}{2} = 7$.

The orbit of $N^{(13)}$ on $\{1, 2, 3, 4, 5, 6, 7\}$ is

$\{2\}, \{1, 5\}, \{3, 6\},$ and $\{4, 7\}$. We now take the representative 6 of the orbit

$\{2\}, \{1, 5\}, \{3, 6\},$ and $\{4, 7\}$

and determine that $Nt_1t_6t_6 = Nt_1t_6 \in [1]$. So 2 of the seven t'_i 's take [16] to [1].

Word of length 3

- $Nt_1t_2t_7N$ is denoted by [127].

We note that $N^{(1,2,7)} \geq N^{127} = 1$. Now $t_1t_2t_7 = t_2t_5t_6, t_3t_6t_5, t_5t_7t_3,$

$t_6t_7t_2, t_4t_3t_7, t_7t_6t_4, t_7t_5t_1, t_1t_4t_6, t_4t_1t_5, t_6t_3t_1, t_5t_2t_4, t_2t_1t_3, t_3t_4t_2$

$(1, 3, 5, 7, 9, 11, 13)(2, 4, 6, 8, 10, 12, 14) \in N^{(127)}$

The number of right cosets in [127] is equal to $\frac{|N|}{|N^{(127)}|} = \frac{14}{14} = 1$.

The orbits of $N^{(127)}$ on $\{1, 2, 3, 4, 5, 6, 7\}$ is

$\{1, 2, 3, 5, 6, 4, 7\}$.

We now take the representative 7 of the orbit

$\{1, 2, 3, 5, 6, 4, 7\}$.

and determine that $Nt_1t_2t_7t_7 = Nt_1t_2t_7 \in [127]$. So all of the seven t'_i 's take [127] to [12].

- $Nt_1t_2t_1N$ is denoted by [121].

We have $N^{(121)} \geq N^{121} = 1$.

Now $t_1t_2t_1 = t_2t_1t_2$.

The number of right cosets in [121] is equal to $\frac{|N|}{|N^{(121)}|} = \frac{14}{2} = 7$.

The orbit of $N^{(121)}$ on $\{1, 2, 3, 4, 5, 6, 7\}$ is

$\{6\}, \{1, 2\}, \{3, 7\},$ and $\{4, 5\}$. We now take the representative 1 of the orbit

$\{6\}, \{1, 2\}, \{3, 7\},$ and $\{4, 5\}$

and determine that $Nt_1t_2t_1t_1 = Nt_1t_2t_1 \in [121]$. So 2 of the seven t'_i 's take [121] to [12].

- $Nt_1t_2t_5N$ is denoted by [125]

We have $N^{(125)} \geq N^{125} = 1$.

Now $t_1t_2t_5 = t_1t_4t_3$.

The number of right cosets in [125] is equal to $\frac{|N|}{|N^{(125)}|} = \frac{14}{2} = 7$.

The orbit of $N^{(125)}$ on $\{1, 2, 3, 4, 5, 6, 7\}$ is

$\{1\}, \{2, 4\}, \{3, 5\},$ and $\{6, 7\}$. We now take the representative 5 of the orbit $\{1\}, \{2, 4\}, \{3, 5\},$ and $\{6, 7\}$

and determine that $Nt_1t_2t_5t_5 = Nt_1t_2 \in [12]$. So 2 of the seven t_i 's take [125] to [12].

Word of length 3

- $Nt_1t_3t_6N$ is denoted by [136].

We note that $N^{(1,2,7)} \geq N^{127} = 1$.

Now $t_1t_3t_6 = t_2t_4t_3t_3t_1t_2, t_5t_1t_4, t_6t_4t_1,$

$t_4t_2t_5, t_7t_2t_1, t_7t_3t_4, t_1t_5t_7, t_4t_6t_7, t_6t_5t_2, t_5t_6t_3, t_2t_7t_6, t_3t_7t_5$

$(1, 3, 5, 7, 9, 11, 13)(2, 4, 6, 8, 10, 12, 14) \in N^{(136)}$

The number of right cosets in [136] is equal to $\frac{|N|}{|N^{(127)}|} = \frac{14}{14} = 1$.

The orbits of $N^{(136)}$ on $\{1,2,3,4,5,6,7\}$ is

$\{1, 2, 3, 5, 6, 4, 7\}$.

We now take the representative 6 of the orbit

$\{1, 2, 3, 5, 6, 4, 7\}$.

and determine that $Nt_1t_3t_6t_6 = Nt_1t_3 \in [13]$. So all of the seven t_i 's take [136] to [13].

- $Nt_1t_3t_1N$ is denoted by [131].

We have $N^{(131)} \geq N^{131} = 1$.

Now $t_1t_3t_1 = t_4t_2t_4$.

The number of right cosets in [131] is equal to $\frac{|N|}{|N^{(121)}|} = \frac{14}{2} = 7$.

The orbit of $N^{(131)}$ on $\{1, 2, 3, 4, 5, 6, 7\}$ is

$\{7\}, \{1, 4\}, \{2, 3\},$ and $\{5, 6\}$. We now take the representative 3 of the orbit $\{7\}, \{1, 4\}, \{2, 3\},$ and $\{5, 6\}$ and determine that $Nt_1t_3t_1t_1 = Nt_1t_3 \in [13]$. So 2 of the seven t_i 's take $[131]$ to $[13]$.

- $Nt_1t_3t_4N$ is denoted by $[134]$

We have $N^{(134)} \geq N^{134} = 1$.

Now $t_1t_3t_4 = t_1t_5t_2$.

The number of right cosets in $[134]$ is equal to $\frac{|N|}{|N^{(121)}|} = \frac{14}{2} = 7$.

The orbit of $N^{(134)}$ on $\{1, 2, 3, 4, 5, 6, 7\}$ is

$\{1\}, \{2, 4\}, \{3, 5\},$ and $\{6, 7\}$. We now take the representative 4 of the orbit $\{1, 2, 3, 4, 5, 6, 7\}$

and determine that $Nt_1t_3t_4t_4 = Nt_1t_3 \in [13]$. So 2 of the seven t_i 's take $[134]$ to $[13]$.

Now, we can construct the Cayley diagram. Since the set of right cosets are closed under right multiplication by t_i^s where $i = 1, 2, 3, 4, 5, 6, 7$, we can determine the index of N in G . We conclude that

$$\begin{aligned}
 |G| &\leq \left| \frac{2 \cdot 7 \cdot D_{14}}{[x^4 * t]^3, [x^3 * t]^3, [x^5 * t]^4} \right| \\
 \implies |G| &\leq (|N| + \frac{|N|}{|N^{(1)}|} + \frac{|N|}{|N^{(12)}|} + \frac{|N|}{|N^{(13)}|} + \frac{|N|}{|N^{(127)}|} + \frac{|N|}{|N^{(136)}|}) \times |N| \\
 \implies |G| &\leq (1 + 7 + 7 + 7 + 1 + 1) \times 14 \\
 \implies |G| &\leq (24 \times 14) \\
 \implies |G| &\leq 366
 \end{aligned}$$

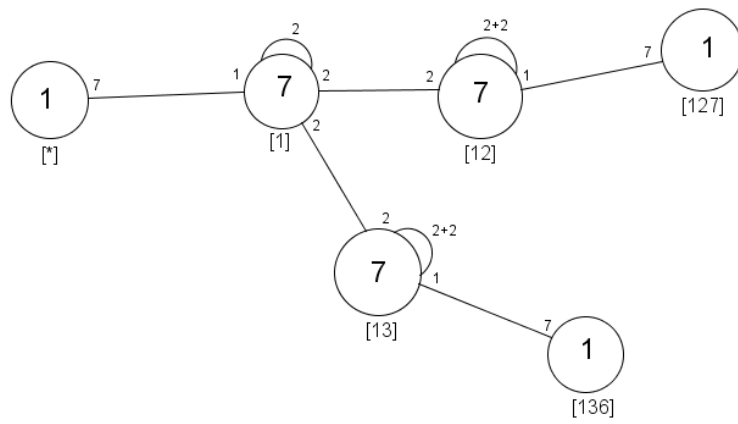

Figure 5.1: Cayley diagram of $PGL(2, 7)$ over D_{14}

Chapter 6

Construction of S_6

6.1 Double Coset Enumeration of S_6

The group $G = \langle x, y, t \mid y^4, x^{-5}, y^{-1} * x^{-2} * y * x^{-1}, t^2, (t, y) \rangle$ factored by $[y^{-1} * x^{-1} * t]^5$ and $[x^2 * t]^6$, where $G = (5 : 4) = \langle x, y \rangle$ with $x \sim (1, 2, 4, 5, 3)$, $y \sim (2, 4, 3, 5)$, and let $t \sim t_1$.

$$\begin{aligned} \text{Now } (y^{-1} * x^{-1} * t)^5 &= e \\ \implies y^{-1}x^{-1}t_1y^{-1}x^{-1}t_1y^{-1}x^{-1}t_1y^{-2}x^{-2}t_3t_1 &= e \\ \implies y^{-1}x^{-1}t_1y^{-1}x^{-1}t_1y^{-3}x^{-3}t_1t_2t_3t_1 &= e \\ \implies y^{-5}x^{-5}t_1t_4t_2t_3t_1 &= e \end{aligned}$$

So $y^{-5}x^{-5}t_1t_4t_2t_3 = t_1$. We also have $Nt_7t_4t_1 = Nt_1$

$$\begin{aligned} \text{Also, } (x^2 * t)^6 &= e \\ x^2t_1x^2t_1x^2t_1x^4t_1t_4t_1 &= e \\ \implies x^2t_1x^2t_1x^8t_2t_3t_4t_1 &= e \\ \implies x^{12}t_1t_2t_3t_4t_1 &= e. \end{aligned}$$

So $x^{12}t_1t_2t_3t_4 = t_1$. We also have

$Nx^{12}t_1t_2t_3t_4 = Nt_1$. Thus,

$$y^{-5}x^{-5}t_1t_4t_2t_3t_1 = (1, 4, 2, 3),$$

$$x^{12}t_1t_2t_3t_4t_1 = (1, 5, 2, 3, 4), \dots$$

We use our technique of double coset enumeration to show that $|G| = \left| \frac{2^{*5} \cdot (5 \times 4)}{[y^{-1}x^{-1}t^*]^5, [x^2t^*]^6} \right| \leq 720$. In order to obtain the index of N in G we shall perform a manual double coset enumeration of G over N ; thus we must find all double cosets $[w] = NwN$ and work out how many single cosets each of them contains. We shall know that we have completed the double coset enumeration when the set of right cosets obtained is closed under right multiplication. Moreover, the completion test above is best performed by obtaining the orbits of $N^{(w)}$ on the symmetric generators. We need only identify, for each $[w]$, the double coset to which the right coset Nwt_i belongs for one symmetric generator t_i from each orbit.

Word of length 0

- NeN is denoted by $[*]$.

$NeN = \{N\}$. The number of right cosets in $[*]$ is equal to $\frac{|N|}{|N|} = \frac{20}{20} = 1$. Since N is transitive on $\{1, 2, 3, 4, 5\}$, The orbit of N on $\{1, 2, 3, 4, 5\}$ is $\{1, 2, 3, 4, 5\}$.

Word of length 1

- Nt_1N is denoted by $[1]$

$N^1 = \langle (2, 4, 3, 5) \rangle = N^{(1)}$. The number of right cosets in $[1]$ is equal to $\frac{|N|}{|N^{(1)}|} = \frac{20}{4} = 5$. The orbits of $N^{(1)}$ on $\{1, 2, 3, 4, 5\}$ are $\{1\}, \{2, 4, 3, 5\}$, We pick a representative, say t_i from each orbit and determine the double cosets that contains Nt_i .

$$Nt_1t_1 \in [*] \text{ (1 goes back to the double coset [*]), since } t_1^2 = e.$$

$$Nt_1t_2 \in [1,2] \text{ (4 goes to the double coset [12])}$$

Thus, t_1 takes $[1]$ to $[*]$ and t_2, t_4, t_3, t_5 take $[1]$ to $[12]$.

Word of length 2

- Nt_1t_2N is denoted by $[12]$.

We note that $N^{(1,2)} \geq N^{12} = 1$.

The number of right cosets in $[12]$ is equal to $\frac{|N|}{|N^{(12)}|} = \frac{20}{1} = 20$.

The orbits of $N^{(12)}$ on $\{1, 2, 3, 4, 5\}$ are $\{1\}, \{2\}, \{3\}, \{4\}, \{5\}$.

We now take the representative 2 of the orbit $\{2\}$.

and determine that $Nt_1t_2t_2 = Nt_1 \in [1]$. So one of the five t'_i s take $[12]$ to $[1]$.

Word of length 3

- $Nt_1t_2t_1N$ is denoted by $[121]$.

We note that $N^{(1,2,1)} \geq N^{121} = 1$.

The number of right cosets in $[121]$ is equal to $\frac{|N|}{|N^{(121)}|} = \frac{20}{4} = 5$ show generators of $N^{(121)}$.

The orbits of $N^{(121)}$ on $\{1, 2, 3, 4, 5\}$ are $\{5\}, \{1, 4, 2, 3\}$.

We now take the representative 1 of the orbit $\{1, 4, 2, 3\}$.

and determine that $Nt_1t_2t_1t_1 = Nt_1t_2 \in [12]$. So one of the five t'_i s take $[121]$ to $[12]$.

- $Nt_1t_2t_4N$ is denoted by $[124]$.

We have $N^{(124)} \geq N^{124} = 1$. Now $t_1t_2t_4 = t_1t_4t_3, t_1t_2t_4 = t_1t_3t_5,$
 $t_1t_2t_4 = t_1t_5t_2,$

The number of right cosets in $[124]$ is equal to show generators of $N^{(124)}$

$$\frac{|N|}{|N^{(124)}|} = \frac{20}{4} = 5.$$

The orbit of $N^{(124)}$ on $\{1, 2, 3, 4, 5\}$ are $\{5\}$, and $\{1, 4, 2, 3\}$. We now take the representative 4 of the orbit $\{1, 2, 3, 4, 5\}$ and determine that $Nt_1t_2t_4t_4 = Nt_1 \in [12]$. So one of the five t_i 's take $[124]$ to $[12]$.

$$|G| = \left| \frac{2 \cdot 5 \cdot D_5}{[y^{-1} * x^{-1} * t]^5, [x^5 * t]^3, [x^2 * t]^6} \right|$$

$$\implies |G| \leq \left(\frac{|N|}{|N|} + \frac{|N|}{|N^{(1)}|} + \frac{|N|}{|N^{(12)}|} + \frac{|N|}{|N^{(121)}|} + \frac{|N|}{|N^{(124)}|} \right) \times |N|$$

$$\implies |G| \leq (1 + 5 + 20 + 5 + 5) \times 20$$

$$\implies |G| \leq (36 \times 20)$$

$$\implies |G| \leq 720$$

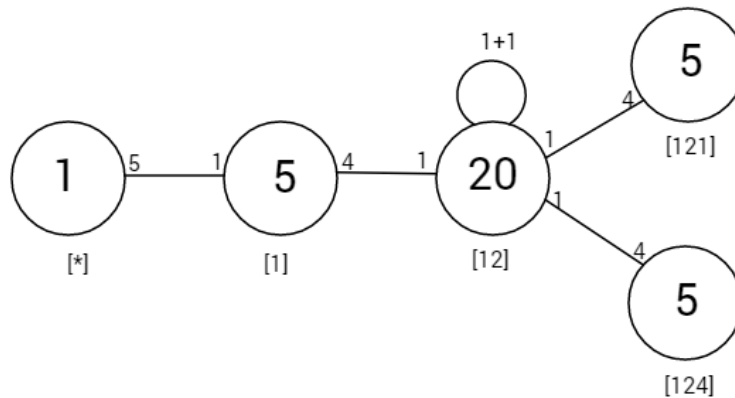

Figure 6.1: Cayley diagram of S_6 over $(5 : 4)$

6.2 Proof of $G \cong S_6$

```
> G<x,y,t>:=Group<x,y,t|y^4,x^5,y^-1*x^-2*y*x^-1,t^2,
(t,y),(y^-1*x^-1*t)^5,
(x^2*t)^6>;
```

```

> #G;
720
>
> f,G1,k:=CosetAction(G,sub<G|x,y>);
> IN:=sub<G1|f(x),f(y)>;
> CompositionFactors(G1);
  G
  | Cyclic(2)
  *
  | Alternating(6)
  1
> s:=IsIsomorphic(G1,Sym(6));
> s;
true

```

6.3 Magma Work for S_6

```

S:=Sym(5);
xx:=S!(1, 2, 4, 5, 3);
yy:=S!(2, 4, 3, 5);
N:=sub< S|xx,yy >;
# N;
G< x,y,t > := Group< x,y,t|y4,x-5,y-1*x-2*y*x-1,t2,(t,y),(y-1*x-1*
t)5,(x2*t)6 >;
# G;
f,G1,k:=CosetAction(G,sub< G|x,y >);
IN:=sub< G1|f(x),f(y) >;
CompositionFactors(G1);
# DoubleCosets(G,sub< G|x,y >,sub< G|x,y >);
DoubleCosets(G,sub< G|x,y >, sub< G|x,y >);
NN< a,b > := Group< a,b|b4,a-5,b-1*a-2*b*a-1 >;
Sch:=SchreierSystem(NN,sub< NN|Id(NN) >);
ArrayP:=[Id(N): i in [1..20]];
for i in [2 .. 20] do

```



```

P:=Id(N): 1 in [1..# Sch[i]];
for j in [1..# Sch[i]] do
if Eltseq(Sch[i])[j] eq 1 then P[j]:=xx; end if;
if Eltseq(Sch[i])[j] eq -1 then P[j]:=xx-1; end if;
if Eltseq(Sch[i])[j] eq 2 then P[j]:=yy; end if;
if Eltseq(Sch[i])[j] eq -2 then P[j]:=yy-1; end if;
end for;
PP:=Id(N);
for k in [1..# P] do
PP:=PP*P[k]; end for;
ArrayP[i]:=PP;
end for;
for i in [1 .. 20] do if ArrayP[i]
eq N! (2, 4, 3, 5)
then Sch[i];
end if; end for;
prodim := function(pt, Q, I)
v:=pt;
for i in I do
v:=v(Q[i]);
end for;
return v;
end function;
ts := [ Id(G1): i in [1 .. 5] ];
ts[1]:=f(t); ts[2]:=f(tx); ts[3]:=f(t(x4)); ts[4]:=f(t(x2)); ts[5]:=f(t(x3));
cst:=[null : i in [1 .. Index(G,sub< G|x, y >)]]
where null is [Integers( ) | ];
for i := 1 to 5 do
cst[prodim(1, ts, [i])]:=i;
end for;
m:=0; for i in [1 .. 36] do if cst[i] ne [ ]

```

```
then m:=m+1; end if; end for; m;
```

```
N1:=Stabiliser(N,[1]);
S:=[1];
SS:=SN;
SSS:=Setseq(SS);
for i in [1 .. # SS] do
  for g in IN do
    if ts[1] eq g*ts[Rep(SSS[i])[1]]
    then print SSS[i];
    end if; end for; end for;
N1s:=N1;
# N1s;
T1:=Transversal(N,N1s);
# T1;
for i := 1 to # T1 do
  ss := [1]T1[i];
  cst[prodim(1, ts, ss)] := ss;
end for;
m:=0;for i in [1 .. 36] do if cst[i] ne [ ]
then m:=m+1; end if; end for; m;
Orbits(N1s);
```

```
N12:=Stabiliser(N,[1,2]);
S:=[1,2];
SS:=SN;
SSS:=Setseq(SS);
for i in [1 .. # SS] do
```

```

for g in IN do if ts[1]*ts[2]
eq g*ts[Rep(SSS[i])[1]]*ts[Rep(SSS[i])[2]]
then print SSS[i];
end if; end for; end for;
N12s:=N12;
# N12s;
T12:=Transversal(N,N12s);
# T12;
for i := 1 to # T12 do
ss := [1, 2]T12[i];
cst[prodim(1, ts, ss)] := ss;
end for;
m:=0;
for i in [1 .. 36] do if cst[i] ne [ ]
then m:=m+1; end if; end for; m;
Orbits(N12s);

N121:=Stabiliser(N,[1,2,1]);
S:=[1,2,1];
SS:=SN;
SSS:=Setseq(SS);
for i in [1 .. # SS] do
for g in IN do if ts[1]*ts[2]*ts[1]
eq g*ts[Rep(SSS[i])[1]]*ts[Rep(SSS[i])[2]]
*ts[Rep(SSS[i])[3]]
then print SSS[i];
end if; end for; end for;
N121s:=N121;
# N121s;
T121:=Transversal(N,N121s);

```

```

# T121;
for i := 1 to # T121 do
ss := [1, 2, 1]T121[i];
cst[prodim(1, ts, ss)] := ss;
end for;
m:=0;
for i in [1 .. 36] do if cst[i] ne [ ]
then m:=m+1; end if; end for; m;
Orbits(N121s);

N123:=Stabiliser(N,[1,2,3]);
S:=[1,2,3]; SS:=SN;
SSS:=Setseq(SS);
for i in [1 .. # SS] do
for g in IN do if ts[1]*ts[2]*ts[3]
eq g*ts[Rep(SSS[i])[1]]*ts[Rep(SSS[i])[2]]
*ts[Rep(SSS[i])[3]]
then print SSS[i];
end if; end for; end for;
N123s:=N123;
# N123s;
T123:=Transversal(N,N123s);
# T123;
for i := 1 to # T123 do
ss := [1, 2, 3]T123[i];
cst[prodim(1, ts, ss)] := ss;
end for;
m:=0;
for i in [1 .. 36] do if cst[i] ne [ ]

```

```

then m:=m+1; end if; end for; m;
Orbits(N123s);

```

```

N124:=Stabiliser(N,[1,2,4]);
S:=[1,2,4];
SS:=SN;
SSS:=Setseq(SS);
for i in [1 .. # SS] do
for g in IN do if ts[1]*ts[2]*ts[4]
eq g*ts[Rep(SSS[i])[1]]*ts[Rep(SSS[i])[2]]
*ts[Rep(SSS[i])[3]]
then print SSS[i];
end if; end for; end for;
N124s:=N124;
# N124s;
T124:=Transversal(N,N124s);
# T124;
for i := 1 to # T124 do
ss := [1, 2, 4]T124[i];
cst[prodim(1, ts, ss)] := ss;
end for;
m:=0;
for i in [1 .. 36] do if cst[i] ne [ ]
then m:=m+1; end if; end for; m;
Orbits(N124s);

```

```

N125:=Stabiliser(N,[1,2,5]);
S:=[1,2,5];

```

```

SS:=SN;
SSS:=Setseq(SS);
for i in [1 .. # SS] do
for g in IN do if ts[1]*ts[2]*ts[5]
eq g*ts[Rep(SSS[i])[1]]*ts[Rep(SSS[i])[2]]
*ts[Rep(SSS[i])[3]]
then print SSS[i];
end if; end for; end for;
N125s:=N125;
# N125s;
T125:=Transversal(N,N125s);
# T125;
T125:=Transversal(N,N125s);
for i := 1 to # T125 do
ss := [1, 2, 5]T125[i];
cst[prodim(1, ts, ss)] := ss;
end for;
m:=0;
for i in [1 .. 36] do if cst[i] ne [ ]
then m:=m+1; end if; end for; m;
Orbits(N125s);

```

```

N1215:=Stabiliser(N,[1,2,1,5]);
S:=[1,2,1,5];
SS:=SN;
SSS:=Setseq(SS);
for i in [1 .. # SS] do
for g in IN do if ts[1]*ts[2]*ts[1]*ts[5]
eq g*ts[Rep(SSS[i])[1]]*ts[Rep(SSS[i])[2]]

```

```

*ts[Rep(SSS[i])[3]]*ts[Rep(SSS[i])[4]]
then print SSS[i];
end if; end for; end for;
N1215s:=N1215;
# N1215s;
T1215:=Transversal(N,N1215s);
# T1215;
for i := 1 to # T1215 do ss := [1, 2, 1, 5]T1215[i];
cst[prodim(1, ts, ss)] := ss;
end for;
m:=0;
for i in [1 .. 36] do if cst[i] ne [ ]
then m:=m+1; end if; end for; m;
Orbits(N1215s);

```

```

N1245:=Stabiliser(N,[1,2,4,5]);
S:=[1,2,4,5];
SS:=SN;
SSS:=Setseq(SS);
for i in [1 .. # SS] do
for g in IN do if ts[1]*ts[2]*ts[4]*ts[5]
eq g*ts[Rep(SSS[i])[1]]*ts[Rep(SSS[i])[2]]
*ts[Rep(SSS[i])[3]]*ts[Rep(SSS[i])[4]]
then print SSS[i];
end if; end for; end for;
N1245s:=N1245;
# N1245s;
T1245:=Transversal(N,N1245s);
# T1245;

```

```
for i := 1 to # T1245 do ss := [1, 2, 4, 5]T1245[i];
cst[prodim(1, ts, ss)] := ss;
end for;
m:=0;
for i in [1 .. 36] do if cst[i] ne [ ]
then m:=m+1; end if; end for; m;
Orbits(N1245s);
```

Chapter 7

Construction of S_7 over $(15 : 4)$

7.1 Double Coset Enumeration of S_7 over $(15 : 4)$

We factor the progenitor $2^{*15} : (15 : 4)$. The group $G = \langle x, y, t | y^4, y^{-1} * x^{-2} * y * x^{-1}, t^2, (t, y) \rangle$ factored by $[y^{-1} * x^{-1} * t]^6$, $[x^2 * t]^4$, $x^2 * y^{-1} * x^{-1} * t * x^{-1} * y * x^2 * t * x^{-1} * y^2 * x^{-1} * t$, and $[x * t * x^{-1} * t]^4$ where $N = (15 : 4) = \langle x, y \rangle$ with $x \sim (1, 2, 6, 3, 8, 14, 10, 7, 12, 11, 15, 13, 5, 9, 4)$, $y \sim (2, 7, 8, 9)(3, 10, 5, 11)(4, 12, 13, 6)$, and let $t \sim t_1$.

$$\begin{aligned}
 & \text{Now } (y^{-1}x^{-1}t)^6 = e \\
 \implies & y^{-1}x^{-1}ty^{-1}x^{-1}ty^{-1}x^{-1}ty^{-1}x^{-1}ty^{-1}x^{-1}ty^{-1}x^{-1}t = e \\
 \implies & y^{-6}x^{-6}t_8t_{14}t_5t_1 = e \\
 \implies & y^{-6}x^{-6}t_8t_{14}t_5 = e
 \end{aligned}$$

So $y^{-6}x^{-6}t_8t_{14}t_5 = t_1$. We also have $Nt_8t_{14}t_5 = Nt_1$

$$\begin{aligned}
 & \text{Now } (x^2 * t)^4 = e \\
 \implies & x^2 * tx^2 * tx^2 * tx^2 * t = e \\
 \implies & x^8t_{10}t_8t_6t_1 = e \\
 \implies & x^8t_{10}t_8t_6 = t_1 = e
 \end{aligned}$$

So $x^8t_{10}t_8t_6 = t_1$. We also have $Nt_{10}t_8t_6 = Nt_1$

$$\text{Now } x^2 * y^{-1} * x^{-1} * t * x^{-1} * y * x^2 * t * x^{-1} * y^2 * x^{-1} * t = e$$

$$\begin{aligned}
\implies x^2 * y^{-1} * x^{-1} * t * x^{-1} * y * x^2 * t * x^{-1} * y^2 * x^{-1} * t &= e \\
\implies x^{-1} y^2 x^{-1} t_{11} t_{15} t_1 &= e \\
\implies x^{-1} y^2 x^{-1} t_{11} t_{15} &= e
\end{aligned}$$

So $x^{-1} y^2 x^{-1} t_{11} t_{15} = t_1$. We also have $N t_{11} t_{15} = N t_1$

$$\begin{aligned}
\text{Also, } (x * t * x^{-1} * t)^4 &= e \\
x * t * x^{-1} * t x * t * x^{-1} * t x * t * x^{-1} * t x * t * x^{-1} * t &= e \\
\implies t_2 t_1 t_2 t_1 t_2 t_1 t_2 t_1 &= e
\end{aligned}$$

So $t_2 t_1 t_2 t_1 t_2 t_1 t_2 = t_1$. We also have

$N t_2 t_1 t_2 t_1 t_2 t_1 t_2 = N t_1$. Thus,

$$\begin{aligned}
t_{11} t_6 t_1 &= (1, 14, 13, 12, 11, 10, 9, 8, 7, 6, 5, 4, 3, 2), \\
t_7 t_4 t_1 &= (1, 6, 11, 2, 7, 12, 3, 8, 13, 4, 9, 14, 5, 10), \dots
\end{aligned}$$

We use our technique of double coset enumeration to show that

$$|G| = \frac{2^{*15} : (15:4)}{|[y^{-1} * x^{-1} * t]^6, [x^2 * t]^4, x^2 * y^{-1} * x^{-1} * t * x^{-1} * y * x^2 * t * x^{-1} * y^2 * x^{-1} * t, [x * t * x^{-1} * t]^4|} \leq 40320.$$

In order to obtain the index of N in G we shall perform a manual double coset enumeration of G over N ; (thus we must find all double cosets $[w] = NwN$ and work out how many single cosets each of them contains. We shall know that we have completed the double coset enumeration when the set of right cosets obtained is closed under right multiplication. Moreover, the completion test above is best performed by obtaining the orbits of $N^{(w)}$ on the symmetric generators. We need only identify, for each $[w]$, the double coset to which the right coset Nwt_i belongs for one symmetric generator t_i from each orbit.)

Word of length 0

- NeN is denoted by $[*]$.

$NeN = \{N\}$. The number of right cosets in $[*]$ is equal to $\frac{|N|}{|N|} = \frac{60}{60} = 1$. Since N is transitive on $\{1, 2, 3, 4, 5, 6, 7, 8, 9, 10, 11, 12, 13, 14, 15\}$,

The orbit of N on $\{1, 2, 3, 4, 5, 6, 7, 8, 9, 10, 11, 12, 13, 14, 15\}$ is $\{1, 2, 3, 4, 5, 6, 7, 8, 9, 10, 11, 12, 13, 14, 15\}$.

Word of length 1

- Nt_1N is denoted by $[1]$

$$N^1 = \langle (2, 7, 8, 9)(3, 10, 5, 11)(4, 12, 13, 6) \rangle = N^{(1)}.$$

The number of right cosets in $[1]$ is equal to

$\frac{|N|}{|N^{(1)}|} = \frac{60}{4} = 15$. The orbits of $N^{(1)}$ on $\{1, 2, 3, 4, 5, 6, 7, 8, 9, 10, 11, 12, 13, 14, 15\}$ are $\{1\}, \{14\}, \{15\}, \{2, 7, 8, 9\}, \{3, 10, 5, 11\}, \{4, 12, 13, 6\}$.

We pick a representative, say t_i from each orbit and determine the double cosets that contains Nt_i .

$$Nt_1t_1 \in [*] \text{ since } t_1^2 = e.$$

So,

t_1 takes $[1]$ to $[*]$.

$$Nt_1t_{14} \in [1] \text{ (1 goes back to the double coset [1])}.$$

$$Nt_1t_{15} \in [1] \text{ (1 goes back to the double coset [1])}.$$

$$Nt_1t_2 \in [12] \text{ (4 goes to the double coset [12])}.$$

$$Nt_1t_3 \in [13] \text{ (4 goes to the double coset [13])}.$$

$$Nt_1t_4 \in [13] \text{ (4 goes to the double coset [13])}.$$

$$Nt_1t_4 \in [12] \text{ (4 goes back to the double coset [*])}.$$

Word of length 2

- Nt_1t_2N is denoted by $[12]$.

We note that $N^{(1,2)} \geq N^{12} = 1$.

Now $(2, 7, 8, 9)(3, 10, 5, 11)(4, 12, 13, 6) \in N^{(12)}$

Thus $N^{(12)} \geq \langle (2, 7, 8, 9)(3, 10, 5, 11)(4, 12, 13, 6) \rangle, \cong D_{15}$.

The number of right cosets in [12] is equal to $\frac{|N|}{|N^{(12)}|} = \frac{60}{1} = 60$.

The orbits of $N^{(12)}$ on $\{1, 2, 3, 4, 5, 6, 7, 8, 9, 10, 11, 12, 13, 14, 15\}$ is $\{1\}, \{2\}, \{3\}, \{4\}, \{5\}, \{6\}, \{7\}, \{8\}, \{9\}, \{10\}, \{11\}, \{12\}, \{13\}, \{14\}, \{15\}$.

We now take the representative 3 of the orbit $\{2\}$.

and determine that $Nt_1t_2t_2 = Nt_1 \in [1]$. So one t_i 's take [12] to [1].

- Nt_1t_3N is denoted by [13].

We have $N^{(13)} \geq N^{13} = 1$.

Now $(2, 7, 8, 9)(3, 10, 5, 11)(4, 12, 13, 6) \in N^{15}$.

Thus $N^{(13)} \geq$

$< (2, 7, 8, 9)(3, 10, 5, 11)(4, 12, 13, 6) >$

The number of right cosets in [13] is equal to

$$\frac{|N|}{|N^{(13)}|} = \frac{60}{1} = 60.$$

The orbit of $N^{(13)}$ on $\{1, 2, 3, 4, 5, 6, 7, 8, 9, 10, 11, 12, 13, 14, 15\}$ is $\{1\}, \{2\}, \{3\}, \{4\}, \{5\}, \{6\}, \{7\}, \{8\}, \{9\}, \{10\}, \{11\}, \{12\}, \{13\}, \{14\}, \{15\}$.

We now take the representative 3 of the orbit

$\{1, 2, 3, 4, 5, 6, 7, 8, 9, 10, 11, 12, 13, 14, 15\}$

and determine that $Nt_1t_3t_3 = Nt_1 \in [1]$. So one t_i 's take [13] to [1].

- Nt_1t_4N is denoted by [14]

We have $N^{(14)} \geq N^{14} = 1$.

Now $(2, 7, 8, 9)(3, 10, 5, 11)(4, 12, 13, 6) \in N^{(14)}$.

Thus $N^{(14)} \geq < (2, 7, 8, 9)(3, 10, 5, 11)(4, 12, 13, 6) >$

We now take the representative 7 of the orbit

$\{1, 2, 3, 4, 5, 6, 7, 8, 9, 10, 11, 12, 13, 14, 15\}$

and determine that $Nt_1t_4t_4 = Nt_1 \in [1]$. So one t_i 's take [14] to [1].

The number of right cosets in [14] is equal to $\frac{|N|}{|N^{(14)}|} = \frac{60}{1} = 60$. The orbit of $N^{(14)}$ on $\{1, 2, 3, 4, 5, 6, 7, 8, 9, 10, 11,$

$12, 13, 14, 15\}$ is $\{1\}, \{2\}, \{3\}, \{4\}, \{5\}, \{6\}, \{7\},$

$\{8\}, \{9\}, \{10\}, \{11\}, \{12\}, \{13\}, \{14\}, \{15\}$.

Now, we can construct the Cayley diagram. Since the set of right cosets are closed under right multiplication by t_i^s where $i = 1, 2, 3, 4, 5, 6, 7, 8, 9, 10, 11, 12, 13, 14, 15$, we can determine the index of N in G . We conclude that

$$|G| \leq \left| \frac{2^{*15}:(15:4)}{[y^{-1}*x^{-1}*t]^6, [x^2*t]^4, x^2*y^{-1}*x^{-1}*t*x^{-1}*y*x^2*t*x^{-1}*y^2*x^{-1}*t, [x*t*x^{-1}*t]^4} \right|$$

$$|G| \leq (|N| + \frac{|N|}{|N^{(1)}|} + \frac{|N|}{|N^{(12)}|} + \frac{|N|}{|N^{(13)}|} + \frac{|N|}{|N^{(121)}|} + \frac{|N|}{|N^{(124)}|} + \frac{|N|}{|N^{(128)}|} + \frac{|N|}{|N^{(129)}|} + \frac{|N|}{|N^{(1214)}|} + \frac{|N|}{|N^{(131)}|} + \frac{|N|}{|N^{(135)}|} + \frac{|N|}{|N^{(1310)}|} + \frac{|N|}{|N^{(1216)}|} + \frac{|N|}{|N^{(12414)}|} + \frac{|N|}{|N^{(12915)}|} + \frac{|N|}{|N^{(13111)}|} + \frac{|N|}{|N^{(13511)}|} + \frac{|N|}{|N^{(135111)}|}) \times |N|$$

$$\implies |G| \leq (1+15+60+60+60+60+60+60+60+15+60+5+60+60+15+5+15+1) \times 60$$

$$\implies |G| \leq (672 \times 60)$$

$$\implies |G| \leq 40320$$

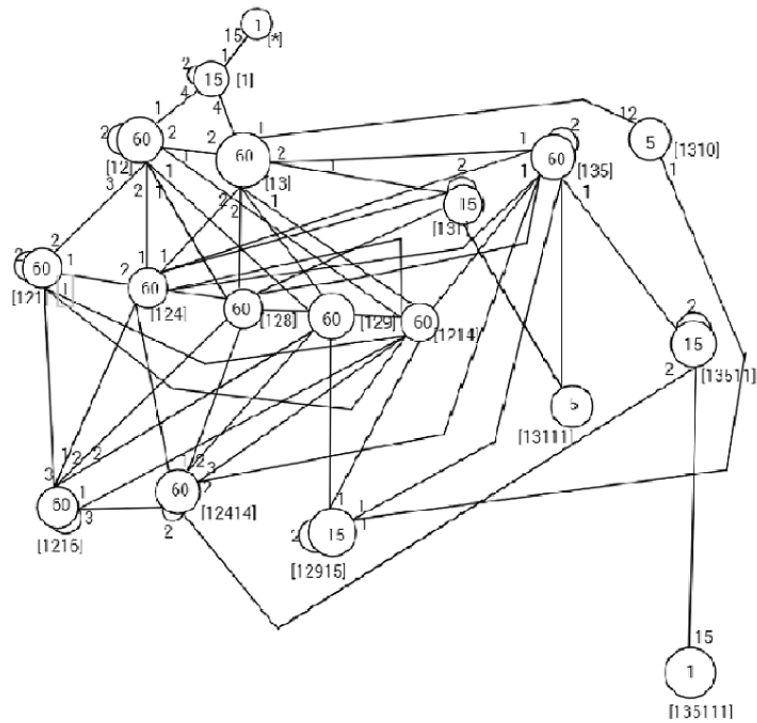
Figure 7.1: Cayley diagram of S_7 over $(15:4)$

7.2 Proof of $G \cong S_7$

```

> G<x,y,t>:=Group<x,y,t|y^4,y^-1*x^-2*y*x^-1,t^2,(t,y),
> (y^-1*x^-1*t)^6,
> (x^2*t)^4, x^2 * y^-1 * x^-1 * t * x^-1 * y * x^2 * t *
> x^-1 * y^2 * x^-1 *
> t,(x * t * x^-1 * t)^4>;
> #G;
40320
> f,G1,k:=CosetAction(G,sub<G|x,y>);
> CompositionFactors(G1);
G
| Cyclic(2)
*
| Alternating(8)
1
> s:=IsIsomorphic(G1,Sym(8));
> s>true

```

Chapter 8

Unsuccessful Progenitors

- $2^{*18} : D_{14}$

```

for a,b,c,d,e,f,g,h,i,j,k,l,m,n,o in [0..10] do;
G<x,y,t>:=Group<x,y,t|y^2,(x^-1*y)^2,x^14,t^2,
(t,y*x^2),(x^7*t)^a,(y*t)^b,(y*t)^c,(y*t)^d,
(y*t)^e,(y*x)^f,(y*x)^g,(y*x)^h,(y*x)^i,(x^2*t)^j,
(x^6*t)^k,(x^4*t)^l,(x*t)^m,(x^3*t)^n,(x^5*t)^o >;
if #G gt 28 then a,b,c,d,e,f,g,h,i,j,k,l,m,n,o,
#G; end if; end for;

```

```

0 0 0 0 0 0 0 0 0 0 0 0 0 0 0 0 0 5 2 6 2 7 6 2
0 0 0 0 0 0 0 0 0 0 0 0 0 0 0 0 0 5 2 6 2 7 7 2
0 0 0 0 0 0 0 0 0 0 0 0 0 0 0 0 0 5 2 6 2 7 8 2
0 0 0 0 0 0 0 0 0 0 0 0 0 0 0 0 0 5 2 6 2 7 9 2
0 0 0 0 0 0 0 0 0 0 0 0 0 0 0 0 0 5 2 6 2 7 10 2
0 0 0 0 0 0 0 0 0 0 0 0 0 0 0 0 0 5 2 6 2 8 0 4
0 0 0 0 0 0 0 0 0 0 0 0 0 0 0 0 0 5 2 6 2 8 1 2
0 0 0 0 0 0 0 0 0 0 0 0 0 0 0 0 0 5 2 6 2 8 2 4
0 0 0 0 0 0 0 0 0 0 0 0 0 0 0 0 0 5 2 6 2 8 3 2
0 0 0 0 0 0 0 0 0 0 0 0 0 0 0 0 0 5 2 6 2 8 4 4
0 0 0 0 0 0 0 0 0 0 0 0 0 0 0 0 0 5 2 6 2 8 5 2
0 0 0 0 0 0 0 0 0 0 0 0 0 0 0 0 0 5 2 6 2 8 6 4
0 0 0 0 0 0 0 0 0 0 0 0 0 0 0 0 0 5 2 6 2 8 7 2
0 0 0 0 0 0 0 0 0 0 0 0 0 0 0 0 0 5 2 6 2 8 8 4
0 0 0 0 0 0 0 0 0 0 0 0 0 0 0 0 0 5 2 6 2 8 9 2
0 0 0 0 0 0 0 0 0 0 0 0 0 0 0 0 0 5 2 6 2 8 10 4
0 0 0 0 0 0 0 0 0 0 0 0 0 0 0 0 0 5 2 6 2 9 0 2
0 0 0 0 0 0 0 0 0 0 0 0 0 0 0 0 0 5 2 6 2 9 1 2
0 0 0 0 0 0 0 0 0 0 0 0 0 0 0 0 0 5 2 6 2 9 2 2

```



```

z*v)^2))^^(z^-1))^nn, (y*(t^(y*v))^z)^oo, (v*t)^pp, (v*
(t^y)^x)^qq, (v*t^(x*v))^rr, (z*v*t)^ss, (z*v*(t^((x*
v)^2))^y)^((x*z)^-3))^tt, (z*v*t^(x*v))^uu, (x*z*t)^v
v, (x*z*(t^(y^2))^x)^ww, (x*z*t^y)^xx, (x*z*t^v)^yy,
(x*z*(t^(y*v))^z)^zz, (x*z*t^((y*v)^4))^aaa, (x*
z*s*t)^bbb, (x*z*s*(t^(y^2))^x)^ccc, (x*z*s*t^y)^ddd,
(x*z*s*t^v)^eee, (x*z*s*(t^(y*v))^z)^fff, (x*z*s*t^(y
*v))^ggg, (y*v*t)^hhh, (y*v*t^((x*u)^5))^iii, (y*v*t
^((x*z*v)^3))^jjj, (y*v*t^y)^kkk, (y*v*t^((x*z)^2))
^lll, (y*v*t^(z*v))^mmm, (y*v*t^z)^nnn, (y*v*t^((y)^2))
^ooo, (y*v*t^((x*v)^3))^ppp, (y*v*t^(x*z*s))^qqq, (y*v
*t^((x*z*v)^5))^rrr, (y*v*(t^(x*z*(y*v*(t^(v))^y))^ttt
, (y*v*t^((x*z*v)^6))^uuu, (y*v*(t^((x*v)^2)^z))^vvv,
(y*v*(t^((x*z*v)^2))^z^-1))^www, (x*v*t)^xxx, (x*v*
t^((y*v)^4))^yyy, (x*v*(t^(x*z*s))^y)^((x*z*v))^zzz,
(x*v*t^y)^a(x*v*t^((x*z)^2))^bbbb, (x*v*(t^(z*u))^y)
^cccc, (x*v*t^z)^dddd, (x*v*t^(y^2))^eeee, (x*v*(t^(y^2
))^x)^ffff, (x*v*t^(x*z*s))^gggg, (x*v*(t^(y*v))^z)
^hhhh, (x*v*(t^((x*z*v)^5))^y)^iiii, (x*z*v*t)^jjjj,
(x*z*v*(t^y)^x)^kkkk, (x*z*v*t^((y*v)^2))^llll, (x*v*
(t^((x*z*v)^5))^y)^iiii, (x*z*v*t)^jjjj, (x*z*v*(t^y)
^x)^kkkk, (x*z*v*t^((y*v)^2))^llll, (x*z*v*t^y)^mmmm,
(x*z*v*t^((x*z)^2))^nnnn, (x*z*v*(t^((y*v)^5))^x)^oooo
, (x*z*v*t^z)^pppp, (x*z*v*t^(y^2))^qqqq, (x*z*v*(t^(y
^2))^x)^rrrr, (x*z*v*t^(x*z*s))^ssss, (x*z*v*t^(y*v))
^tttt, (x*z*v*(t^(x*z*s))^y)^uuuu>;a,b,c,d,e,f,g,h,i,
j,k,l,m,n,o,p,q,r,sS,tT,uU,vV,wW,xX,yY,zZ,aa,bb,cc,dd,
ee,ff,gg,hh,ii,jj,kk,ll,mm,nn,oo,pp,qq,rr,ss,tt,uu,vv
,ww,xx,yy,zz,aaa,bbb,ccc,ddd,eee,fff,ggg,hhh,iii,jjj,
kkk,lll,mmm,nnn,ooo,ppp,qqq,rrr,sss,ttt,uuu,vvv,www,
xxx,yyy,zzz,aaaa,bbbb,cccc,dddd,eeee,ffff,gggg,hhhh,
iiii,jj,kkkk,llll,mmmm,nnnn,oooo,pppp,qqqq,rrrr,ssss,
tttt,uuuu,
#G; end for;

```

```

0 0 0 0 0 0 0 0 0 0 0 0 0 0 0 0 5 6 2 1 1 2
0 0 0 0 0 0 0 0 0 0 0 0 0 0 0 0 0 0 0 0 0 0 0 0 0 0
0 0 0 0 0 0 0 0 0 0 0 0 0 0 0
0 0 0 0 0 0 0 0 0 0 0 0 0 0 0 0 0 0 0 0 0 0 0 0 0 0
0 0 0 0 0 0 0 0 0 0 0 0 0 0
0 0 0 0 0 0 0 0 0 0 0 0 0 0 5 6 2 1 2 2
0 0 0 0 0 0 0 0 0 0 0 0 0 0 0 0 0 0 0 0 0 0 0 0 0 0
0 0 0 0 0 0 0 0 0 0 0 0 0 0
0 0 0 0 0 0 0 0 0 0 0 0 0 0 0 0 0 0 0 0 0 0 0 0 0 0

```



```

0 0 0 0 0 0 0 0 0 0 0 0 0 0 0 0 5 6 2 2 0 2
0 0 0 0 0 0 0 0 0 0 0 0 0 0 0 0 0 0 0 0 0 0 0 0
0 0 0 0 0 0 0 0 0 0 0 0 0 0 0
0 0 0 0 0 0 0 0 0 0 0 0 0 0 0 0 0 0 0 0 0 0 0 0
0 0 0 0 0 0 0 0 0 0 0 0 0 0 0
0 0 0 0 0 0 0 0 0 0 0 0 0 0 0 5 6 2 2 1 2
0 0 0 0 0 0 0 0 0 0 0 0 0 0 0 0 0 0 0 0 0 0 0 0
0 0 0 0 0 0 0 0 0 0 0 0 0 0 0
0 0 0 0 0 0 0 0 0 0 0 0 0 0 0 0 0 0 0 0 0 0 0 0
0 0 0 0 0 0 0 0 0 0 0 0 0 0 0
0 0 0 0 0 0 0 0 0 0 0 0 0 0 0 0 0 0 0 0 0 0 0 0
0 0 0 0 0 0 0 0 0 0 0 0 0 0 0
0 0 0 0 0 0 0 0 0 0 0 0 0 0 0 0 0 0 0 0 0 0 0 0
0 0 0 0 0 0 0 0 0 0 0 0 0 0 0
0 0 0 0 0 0 0 0 0 0 0 0 0 0 0 5 6 2 2 2 2
0 0 0 0 0 0 0 0 0 0 0 0 0 0 0 0 0 0 0 0 0 0 0 0
0 0 0 0 0 0 0 0 0 0 0 0 0 0 0
0 0 0 0 0 0 0 0 0 0 0 0 0 0 0 0 0 0 0 0 0 0 0 0
0 0 0 0 0 0 0 0 0 0 0 0 0 0 0 5 6 2 2 3 2
0 0 0 0 0 0 0 0 0 0 0 0 0 0 0 0 0 0 0 0 0 0 0 0
0 0 0 0 0 0 0 0 0 0 0 0 0 0 0
0 0 0 0 0 0 0 0 0 0 0 0 0 0 0 0 0 0 0 0 0 0 0 0
0 0 0 0 0 0 0 0 0 0 0 0 0 0 0
0 0 0 0 0 0 0 0 0 0 0 0 0 0 0 5 6 2 2 4 2

```

• $2^{*14} : D_{28}$

```

for a,b,c,d,e,f,g,h,i,j,k,l,m,n,o in [0..10] do
G<x,y,t>:=Group<x,y,t|y^2,(x^-1*y)^2,x^14,t^2,
(t,y*x^2),(x^7*t)^a,(y*t)^b,(y*t)^c,(y*t)^d,
(y*t)^e,(y*x)^f,(y*x)^g,(y*x)^h,(y*x)^i,(x^2*t)^j,
(x^6*t)^k,(x^4*t)^l,(x*t)^m,(x^3*t)^n,(x^5*t)^o >;
if #G gt 28 then a,b,c,d,e,f,g,h,i,j,k,l,m,n,o,
#G; end if; end for;

```

```

0 0 0 0 0 0 0 0 0 0 0 0 9 6 3 10 10 126
0 0 0 0 0 0 0 0 0 0 0 0 9 6 6 0 2 126
0 0 0 0 0 0 0 0 0 0 0 0 9 6 6 2 0 126
0 0 0 0 0 0 0 0 0 0 0 0 9 6 6 2 2 126
0 0 0 0 0 0 0 0 0 0 0 0 9 6 6 2 4 126

```

0 0 0 0 0 0 0 0 0 0 0 0 9 6 6 2 6 126
0 0 0 0 0 0 0 0 0 0 0 0 9 6 6 2 8 126
0 0 0 0 0 0 0 0 0 0 0 0 9 6 6 2 10 126
0 0 0 0 0 0 0 0 0 0 0 0 9 6 6 4 2 126
0 0 0 0 0 0 0 0 0 0 0 0 9 6 6 4 6 126
0 0 0 0 0 0 0 0 0 0 0 0 9 6 6 4 10 126
0 0 0 0 0 0 0 0 0 0 0 0 9 6 6 6 2 126
0 0 0 0 0 0 0 0 0 0 0 0 9 6 6 6 4 126
0 0 0 0 0 0 0 0 0 0 0 0 9 6 6 6 8 126
0 0 0 0 0 0 0 0 0 0 0 0 9 6 6 6 10 126
0 0 0 0 0 0 0 0 0 0 0 0 9 6 6 8 2 126
0 0 0 0 0 0 0 0 0 0 0 0 9 6 6 8 6 126
0 0 0 0 0 0 0 0 0 0 0 0 9 6 6 8 10 126
0 0 0 0 0 0 0 0 0 0 0 0 9 6 6 10 2 126
0 0 0 0 0 0 0 0 0 0 0 0 9 6 6 8 10 126
0 0 0 0 0 0 0 0 0 0 0 0 9 6 6 10 2 126
0 0 0 0 0 0 0 0 0 0 0 0 9 6 6 10 4 126
0 0 0 0 0 0 0 0 0 0 0 0 9 6 6 10 6 126
0 0 0 0 0 0 0 0 0 0 0 0 9 6 6 10 8 126
0 0 0 0 0 0 0 0 0 0 0 0 9 6 9 0 2 378
0 0 0 0 0 0 0 0 0 0 0 0 9 6 9 2 0 378
0 0 0 0 0 0 0 0 0 0 0 0 9 6 9 2 2 378
0 0 0 0 0 0 0 0 0 0 0 0 9 6 9 2 4 378
0 0 0 0 0 0 0 0 0 0 0 0 9 6 9 2 6 378
0 0 0 0 0 0 0 0 0 0 0 0 9 6 9 2 8 378
0 0 0 0 0 0 0 0 0 0 0 0 9 6 9 2 10 378
0 0 0 0 0 0 0 0 0 0 0 0 9 6 9 4 2 378
0 0 0 0 0 0 0 0 0 0 0 0 9 6 9 4 6 378
0 0 0 0 0 0 0 0 0 0 0 0 9 6 9 4 10 378
0 0 0 0 0 0 0 0 0 0 0 0 9 6 9 6 2 378
0 0 0 0 0 0 0 0 0 0 0 0 9 6 9 6 4 378
0 0 0 0 0 0 0 0 0 0 0 0 9 6 9 6 8 378
0 0 0 0 0 0 0 0 0 0 0 0 9 6 9 6 10 378
0 0 0 0 0 0 0 0 0 0 0 0 9 6 9 6 8 378
0 0 0 0 0 0 0 0 0 0 0 0 9 6 9 6 10 378
0 0 0 0 0 0 0 0 0 0 0 0 9 6 9 8 2 378
0 0 0 0 0 0 0 0 0 0 0 0 9 6 9 8 6 378
0 0 0 0 0 0 0 0 0 0 0 0 9 6 9 8 10 378
0 0 0 0 0 0 0 0 0 0 0 0 9 6 9 10 2 378
0 0 0 0 0 0 0 0 0 0 0 0 9 6 9 10 4 378
0 0 0 0 0 0 0 0 0 0 0 0 9 6 9 10 6 378
0 0 0 0 0 0 0 0 0 0 0 0 9 6 9 10 8 378

Appendix A

Magma Work for $2^4 : (5 : 4)$

```

S:=Sym(5);
xx:=S!(1,2,4,5,3);
yy:=S!(2,4,3,5);
N:=sub<S|xx,yy>;
Stabiliser(N,1);
#N;

G<x,y,t>:= Group <x,y,t|x^5,y^4,y^{-1}*x^{-2}*y*x^{-1},
t^2(t,y), (x^{-2}*y^{-2}*t^{x^3})^4,(y^{-1}*x^{-1}*t)^8,
(x^2*t)^5>
f,G1,k:=CosetAction(G,sub<G|x,y> );
IN:=sub<G1|f(x),f(y)>;
CompositionFactors(G1);
#DoubleCosets(G,sub<G|x,y>,sub<G|x,y>);
DoubleCosets(G,sub<G|x,y>,sub<G|x,y>);
NN<a,b> := Group<a,b|a^5,b^4,b^{-1}*a^{-2}*b*a^{-1}>;
Sch := SchreierSystem(NN,sub<NN|Id(NN)>);
ArrayP:=[Id(N): i in [1 .. 20]];
for i in [2 .. 20] do
P :=[Id(N): l in [1 .. #Sch[i]]];
for j in [1..#Sch[i]] do
if Eltseq (Sch[i])[j] eq 1 then P[j]:=xx; end if;
if Eltseq (Sch[i])[j] eq -1 then P[j]:=xx^{-1}; end if;
if Eltseq (Sch[i])[j] eq 2 then P[j]:=yy; end if;
if Eltseq (Sch[i])[j] eq -2 then P[j]:=yy^{-1}; end if;
end for;
PP:=Id(N);
for k in [1 .. #P] do

```

```

PP:=PP*P[k]; end for;
ArrayP[i]:=PP;
end for;
for i in [1 .. 20] do if ArrayP[i] eq N!(2,4,3,5)
then Sch[i];
end if; end for;
prodim := function(pt, Q, I)
/* Return the image of pt under permutations Q[i]
applied sequentially. */
v:=pt;
for i in I do
v:=$v^{Q[i]}$;
end for;
return v;
end function;
ts := [ Id(G1): i in [1 .. 5] ];
ts[1]:=f(t); ts[2]:=$f(t^x)$; ts[3]:=f$(t^{x^4})$;
ts[4]:=f(t^{x^2}); ts[5]:=f(t^{x^3});

/* This cst function will keep track of all single cosets */

cst:= [null : i in [1 .. Index(G,sub< G[x, y >])]
where null is [Integers() | ];
for i := 1 to 5 do
cst[prodim(1, ts, [i])]:=i];
end for;
m:=0; for i in [1 .. 16] do if cst[i] ne [ ]
then m:=m+1; end if; end for; m;

N1:=Stabiliser(N,[1]);
S:=[1];
SS:=S^N;
SS;
# SS;
SSS:=Setseq(SS);
SSS;

```



```

for i in [1 .. # SS] do
for g in IN do
if ts[1] eq
g*ts[Rep(SSS[i])[1]]
then print SSS[i];
end if; end for; end for;
N1s:=N1;
# N1s;
T1:=Transversal(N,N1s);
# T1;
for i := 1 to # T1 do
SS := [1]T1[i]
cst[prodim(1, ts, SS)] := SS;
end for;
m:=0;
for i in [1 .. 16] do if cst[i] ne [ ]
then m:=m+1; end if; end for; m;
Orbits(N1s);
# N1s;

N12:=Stabiliser(N,[1,2]);
S:=[1,2];
SS:=SN;
SS;
# SS;
SSS:=Setseq(SS);
SSS;
for i in [1 .. # SSS] do
for g in IN do if ts[1]*ts[2] eq
g*ts[Rep(SSS[i])[1]]*ts[Rep(SSS[i])[2]]
then print SSS[i];

```

```

end if; end for; end for;
N12s:=N12;
# N12s;
T12:=Transversal(N,N12s);
# T12;
for i := 1 to #T12 do
SS := [1,2]T12[i];
cst[prodim(1, ts, SS)] := SS;
end for;
m:=0;
for i in [1 .. 16] do if cst[i] ne [ ]
then m:=m+1;
end if; end for; m;
Orbits(N12s);
for m,n in IN do if ts[1]*ts[2] eq m * (ts[1])n
then m,n; end if; end for;

N123:=Stabiliser(N,[1,2,3]);
S:=[1,2,3];
SS:=SN;
SSS:=Setseq(SS);
for i in [1 .. # SS] do
for g in IN do if ts[1]*ts[2]*ts[3] eq
g*ts[Rep(SSS[i])[1]]*ts[Rep(SSS[i])[2]]*ts[Rep(SSS[i])[3]]
then print SSS[i];
end if; end for; end for;
N123s:=N123;
for g in N do if 1g eq 1 and 2g eq 3 and 3g eq 2
then N123s:=sub< N|N123s, g >; end if; end for;
# N123s;
T123:=Transversal(N,N123s);

```

```

# T123;
for i := 1 to #T123 do
SS := [1, 2, 3]T123[i];
cst[prodim(1, ts, SS)] := SS;
end for;
m:=0;
for i in [1 .. 16] do if cst[i] ne [ ]
then m:=m+1; end if; end for; m;
Orbits(N123s);
for m,n in IN do if ts[1]*ts[2]*ts[3] eq m * (ts[1] * ts[2])n
then m,n; end if; end for;

N125:=Stabiliser(N,[1,2,5]);
S:=[1,2,5];
SS:=SN;
SSS:=Setseq(SS);
for i in [1..#SS] do
for g in IN do if ts[1]*ts[2]*ts[5] eq
g*ts[Rep(SSS[i])[1]]*ts[Rep(SSS[i])[2]]*ts[Rep(SSS[i])[3]]
then print SSS[i];
end if; end for; end for;
N125s:=N125;
# N125s;
T125:=Transversal(N,N125s);
# T125;
for i := 1 to # T125 do
SS := [1, 2, 5]T125[i];
cst[prodim(1, ts, SS)] := SS;
end for;
m:=0;
for i in [1 .. 16] do if cst[i] ne [ ] then m:=m+1;

```

```
end if; end for; m;  
Orbits(N125s);  
  
/* To print all single cosets */  
for i in [1 .. 10] do i, cst[i]; end for;
```

Appendix B

Magma Work for S_7

```

S:=Sym(15);
xx:=S!(1, 2, 6, 3, 8, 14, 10, 7, 12, 11, 15, 13, 5, 9, 4);
yy:=S!(2, 7, 8, 9)(3, 10, 5, 11)(4, 12, 13, 6);
N:=sub< S|xx, yy >;
# N;
G< x, y, t > := Group < x, y, t|y4, y-1*x-2*y*x-1, t2, (t, y), (y-1*x-1*t)6, (x2*t)4, x2*y-1*x-1*t*x-1*y*y*x2*t*x-1*y2*x-1*t, (x*t*x-1*t)4 >; # G;
f,G1,k:=CosetAction(G,sub< G|x, y >);
IN:=sub< G1|f(x), f(y) >
CompositionFactors(G1);
NN< a, b >:=Group< a, b|b4, b-1*a-2*b*a-1 >;
Sch:=SchreierSystem(NN,sub< NN|Id(NN) >);
ArrayP:=[Id(N): i in [1 .. 60]];
for i in [2 .. 60] do
P:=[Id(N): l in [1..# Sch[i]]];
for j in [1 .. # Sch[i]] do
if Eltseq(Sch[i])[j] eq 1 then P[j]:=xx; end if;
if Eltseq(Sch[i])[j] eq -1 then P[j]:=xx-1; end if;
if Eltseq(Sch[i])[j] eq 2 then P[j]:=yy; end if;
if Eltseq(Sch[i])[j] eq -2 then P[j]:=yy-1; end if;

```

```

end for;
PP:=Id(N);
for k in [1 .. # P] do
PP:=PP*P[k]; end for;
ArrayP[i]:=PP;
end for;
for i in [1..60] do if ArrayP[i]
eq N!(2, 7, 8, 9)(3, 10, 5, 11)(4, 12, 13, 6)
then Sch[i];
end if; end for;
prodim := function(pt, Q, I)
v:=pt;
for i in I do
v:=v(Q[i]);
end for;
return v;
end function;
ts := [ Id(G1): i in [1 .. 15] ];
ts[1]:=f(t); ts[2]:=f(tx); ts[3]:=f(tx3);
ts[4]:=f(tx14); ts[5]:=f(tx12);
ts[6]:=f(tx2);ts[7]:=f(tx7);
ts[8]:=f(tx4); ts[9]:=f(tx13);
ts[10]:=f(tx6); ts[11]:=f(tx9);
ts[12]:=f(tx8);ts[13]:=f(tx11);
ts[14]:=f(tx5); ts[15]:=f(tx10);
cst:=[null : i in [1 .. Index(G,sub< G|x, y >))]
where null is [Integers( ) | ];
for i := 1 to 15 do
cst[prodim(1, ts, [i])]:=i];
end for;
m:=0; for i in [1 .. 672] do if cst[i] ne [ ]

```

```

then m:=m+1; end if; end for; m;
# DoubleCosets(G,sub< G|x,y >,sub< G|x,y >);

```

```

N1:=Stabiliser(N,1);
S:=[1];
SS:=SN;
SSS:=Setseq(SS);
for i in [1 .. # SS] do
for g in IN do if ts[1]
eq g*ts[Rep(SSS[i])[1]]
then print SSS[i];
end if; end for; end for;
N1s:=N1;
# N1s;
T1:=Transversal(N,N1s);
# T1;
for i:=1 to 15 do
cst[prodim(1, ts, [i])]:= [i];
end for;
m:=0;
for i in [1 .. 672] do if cst[i] ne [ ]
then m:=m+1; end if; end for; m;
Orbits(N1s);

```

```

N114:=Stabiliser(N,[1,14]);
S:=[1,14];
SS:=SN;
SSS:=Setseq(SS); for i in [1 .. # SS] do
for g in IN do if ts[1]*ts[14]
eq g*ts[Rep(SSS[i])[1]]*ts[Rep(SSS[i])[2]]
then print SSS[i];

```

```

end if; end for; end for;
N114s:=N114;
# N114s;
T114:=Transversal(N,N114s);
# T114;
for i := 1 to 15 do
cst[prodim(1, ts, [i])]:= [i];
end for;
m:=0;
for i in [1 .. 672] do if cst[i] ne [ ]
then m:=m+1; end if; end for; m;
Orbits(N114s);

N115:=Stabiliser(N,[1,15]);
S:=[1,15];
SS:=SN;
SSS:=Setseq(SS);
for i in [1 .. # SS] do
for g in IN do if ts[1]*ts[15]
eq g*ts[Rep(SSS[i])[1]]*ts[Rep(SSS[i])[2]]
then print SSS[i];
end if; end for; end for;
N115s:=N115;
# N115s;
T115:=Transversal(N,N115s);
# T115;
for i := 1 to # T115 do
ss := [1, 15]T115[i];
cst[prodim(1, ts, ss)] := ss;
end for;
m:=0;

```



```

for i in [1 .. 672] do if cst[i] ne [ ]
then m:=m+1; end if; end for; m;
Orbits(N115s);

N12:=Stabiliser(N,[1,2]);
S:=[1,2];
SS:=SN;
SSS:=Setseq(SS);
for i in [1 .. # SS] do
for g in IN do if ts[1]*ts[2]
eq g*ts[Rep(SSS[i])[1]]*ts[Rep(SSS[i])[2]]
then print SSS[i];
end if; end for; end for;
N12s:=N12;
# N12s;
T12:=Transversal(N,N12s);
# T12;
Orbits(N12s);
for i := 1 to # T12 do
ss := [1, 2]T12[i];
cst[prodim(1, ts, ss)] := ss;
end for;
m:=0;
for i in [1 .. 672] do if cst[i] ne [ ]
then m:=m+1; end if; end for; m;

N13:=Stabiliser(N,[1,3]);
S:=[1,3];
SS:=SN;
SSS:=Setseq(SS);
for i in [1 .. # SS] do

```

```

for g in IN do if ts[1]*ts[3]
eq g*ts[Rep(SSS[i])[1]]*ts[Rep(SSS[i])[2]]
then print SSS[i];
end if; end for; end for;
N13s:=N13;
# N13s;
T13:=Transversal(N,N13s);
# T13;
for i := 1 to # T13 do
ss := [1, 3]T13[i];
cst[prodim(1, ts, ss)] := ss;
end for;
m:=0;
for i in [1 ..672] do if cst[i] ne [ ]
then m:=m+1; end if; end for; m;
Orbits(N13s);

N14:=Stabiliser(N,[1,4]);
S:=[1,4];
SS:=SN;
SSS:=Setseq(SS);
for i in [1 .. # SS] do for g in IN do if ts[1]*ts[4]
eq g*ts[Rep(SSS[i])[1]]*ts[Rep(SSS[i])[2]]
then print SSS[i];
end if; end for; end for;
N14s:=N14;
# N14s;
T14:=Transversal(N,N14s);
# T14;
for i := 1 to # T14 do
ss := [1, 4]T14[i];

```

```

cst[prodim(1, ts, ss)] := ss;
end for;
m:=0;
for i in [1 .. 672] do if cst[i] ne [ ]
then m:=m+1; end if; end for; m;
Orbits(N14s);

N121:=Stabiliser(N,[1,2,1]);
S:=[1,2,1];
SS:=SN;
SSS:=Setseq(SS);
for i in [1 .. # SS] do
for g in IN do if ts[1]*ts[2]*ts[1]
eq g*ts[Rep(SSS[i])[1]]*ts[Rep(SSS[i])[2]]*ts[Rep(SSS[i])[3]]
then print SSS[i];
end if; end for; end for;
N121s:=N121;
# N121s;
T121:=Transversal(N,N121s);
# T121;
for i := 1 to # T121 do
ss := [1, 2, 1]T121[i];
cst[prodim(1, ts, ss)] := ss;
end for;
m:=0;
for i in [1 .. 672] do if cst[i] ne [ ]
then m:=m+1; end if; end for; m;
Orbits(N121s);

N123:=Stabiliser(N,[1,2,3]);
S:=[1,2,3];

```

```

SS:=SN;
SSS:=Setseq(SS);
for i in [1 .. # SS] do
for g in IN do if ts[1]*ts[2]*ts[3]
eq g*ts[Rep(SSS[i])[1]]*ts[Rep(SSS[i])[2]]*ts[Rep(SSS[i])[3]]
then print SSS[i];
end if; end for; end for;
N123s:=N123;
# N123s;
T123:=Transversal(N,N123s);
# T123;
for i := 1 to # T123 do
ss := [1, 2, 3]T123[i];
cst[prodim(1, ts, ss)] := ss;
end for;
m:=0;
for i in [1 .. 672] do if cst[i] ne [ ]
then m:=m+1; end if; end for; m;
Orbits(N123s);

N124:=Stabiliser(N,[1,2,4]);
S:=[1,2,4];
SS:=SN;
SSS:=Setseq(SS);
for i in [1 .. # SS] do
for g in IN do if ts[1]*ts[2]*ts[4]
eq g*ts[Rep(SSS[i])[1]]*ts[Rep(SSS[i])[2]]*ts[Rep(SSS[i])[3]]
then print SSS[i];
end if; end for; end for;
N124s:=N124;
# N124s;

```

```

T124:=Transversal(N,N124s);
# T124;
for i := 1 to # T124 do
ss := [1, 2, 4]T124[i];
cst[prodim(1, ts, ss)] := ss;
end for;
m:=0;
for i in [1 .. 672] do if cst[i] ne [ ]
then m:=m+1; end if; end for; m;
Orbits(N124s);

N125:=Stabiliser(N,[1,2,5]);
S:=[1,2,5];
SS:=SN;
SSS:=Setseq(SS);
for i in [1 .. # SS] do
for g in IN do if ts[1]*ts[2]*ts[5]
eq g*ts[Rep(SSS[i])[1]]*ts[Rep(SSS[i])[2]]*ts[Rep(SSS[i])[3]]
then print SSS[i];
end if; end for; end for;
N125s:=N125;
# N125s;
T125:=Transversal(N,N125s);
# T125;
for i := 1 to # T125 do
ss := [1, 2, 5]T125[i];
cst[prodim(1, ts, ss)] := ss;
end for;
m:=0;
for i in [1 .. 672] do if cst[i] ne [ ]
then m:=m+1; end if; end for; m;

```

```

Orbits(N125s);

N126:=Stabiliser(N,[1,2,6]);
S:=[1,2,6];
SS:=SN;
SSS:=Setseq(SS);
for i in [1 .. # SS] do
for g in IN do if ts[1]*ts[2]*ts[6]
eq g*ts[Rep(SSS[i])[1]]*ts[Rep(SSS[i])[2]]*ts[Rep(SSS[i])[3]]
then print SSS[i];
end if; end for; end for;
N126s:=N126;
# N126s;
T126:=Transversal(N,N126s);
# T126;
for i := 1 to # T126 do
ss := [1, 2, 6]T126[i];
cst[prodim(1, ts, ss)] := ss;
end for;
m:=0;
for i in [1 .. 672] do if cst[i] ne [ ]
then m:=m+1; end if; end for; m;
Orbits(N126s);

N127:=Stabiliser(N,[1,2,7]);
S:=[1,2,7];
SS:=SN;
SSS:=Setseq(SS);
for i in [1 .. # SS] do
for g in IN do if ts[1]*ts[2]*ts[7]
eq g*ts[Rep(SSS[i])[1]]*ts[Rep(SSS[i])[2]]*ts[Rep(SSS[i])[3]]

```

```

then print SSS[i];
end if; end for; end for;
N127s:=N127;
# N127s;
T127:=Transversal(N,N127s);
# T127;
for i := 1 to # T127 do
ss := [1, 2, 7]T127[i];
cst[prodim(1, ts, ss)] := ss;
end for;
m:=0;
for i in [1..672] do if cst[i] ne [ ]
then m:=m+1; end if; end for; m;
Orbits(N127s);

N128:=Stabiliser(N,[1,2,8]);
S:=[1,2,8];
SS:=SN;
SSS:=Setseq(SS);
for i in [1 .. # SS] do
for g in IN do if ts[1]*ts[2]*ts[8]
eq g*ts[Rep(SSS[i])[1]]*ts[Rep(SSS[i])[2]]*ts[Rep(SSS[i])[3]]
then print SSS[i];
end if; end for; end for;
N128s:=N128;
# N128s;
T128:=Transversal(N,N128s);
# T128;
for i := 1 to # T128 do
ss := [1, 2, 8]T128[i];
cst[prodim(1, ts, ss)] := ss;

```

```

end for;
m:=0;
for i in [1 .. 672] do if cst[i] ne [ ]
then m:=m+1; end if; end for; m;
Orbits(N128s);

N129:=Stabiliser(N,[1,2,9]);
S:=[1,2,9];
SS:=SN;
SSS:=Setseq(SS);
for i in [1 .. # SS] do
for g in IN do if ts[1]*ts[2]*ts[9]
eq g*ts[Rep(SSS[i])[1]]*ts[Rep(SSS[i])[2]]*ts[Rep(SSS[i])[3]]
then print SSS[i];
end if; end for; end for;
N129s:=N129;
# N129s;
T129:=Transversal(N,N129s);
# T129;
for i := 1 to # T129 do
ss := [1, 2, 9]T129[i];
cst[prodim(1, ts, ss)] := ss;
end for;
m:=0;for i in [1 .. 672] do if cst[i] ne [ ]
then m:=m+1; end if; end for; m;
Orbits(N129s);

N1210:=Stabiliser(N,[1,2,10]);
S:=[1,2,10];
SS:=SN;
SSS:=Setseq(SS);

```



```

for i in [1 .. # SS] do
for g in IN do if ts[1]*ts[2]*ts[10]
eq g*ts[Rep(SSS[i])[1]]*ts[Rep(SSS[i])[2]]*ts[Rep(SSS[i])[3]]
then print SSS[i];
end if; end for; end for;
N1210s:=N1210;
# N1210s;
T1210:=Transversal(N,N1210s);
# T1210;
for i := 1 to # T1210 do
ss := [1, 2, 10]T1210[i];
cst[prodim(1, ts, ss)] := ss;
end for;
m:=0;
for i in [1 .. 672] do if cst[i] ne [ ]
then m:=m+1; end if; end for; m;
Orbits(N1210s);

N1211:=Stabiliser(N,[1,2,11]);
S:=[1,2,11];
SS:=SN;
SSS:=Setseq(SS);
for i in [1 .. # SS] do
for g in IN do if ts[1]*ts[2]*ts[11]
eq g*ts[Rep(SSS[i])[1]]*ts[Rep(SSS[i])[2]]*ts[Rep(SSS[i])[3]]
then print SSS[i];
end if; end for; end for;
N1211s:=N1211;
# N1211s;
T1211:=Transversal(N,N1211s);
# T1211;

```

```

for i := 1 to # T1211 do
ss := [1, 2, 11]T1211[i];
cst[prodim(1, ts, ss)] := ss;
end for;
m:=0;
for i in [1 .. 672] do if cst[i] ne [ ]
then m:=m+1; end if; end for; m;
Orbits(N1211s);

N1212:=Stabiliser(N,[1,2,12]);
S:=[1,2,12];
SS:=SN; SSS:=Setseq(SS);
for i in [1 .. # SS] do
for g in IN do if ts[1]*ts[2]*ts[12]
eq g*ts[Rep(SSS[i])[1]]*ts[Rep(SSS[i])[2]]*ts[Rep(SSS[i])[3]]
then print SSS[i];
end if; end for; end for;
N1212s:=N1212;
# N1212s;
T1212:=Transversal(N,N1212s);
# T1212;
for i := 1 to # T1212 do
ss := [1, 2, 12]T1212[i];
cst[prodim(1, ts, ss)] := ss;
end for;
m:=0;
for i in [1 .. 672] do if cst[i] ne [ ]
then m:=m+1; end if; end for; m;
Orbits(N1212s);

N1213:=Stabiliser(N,[1,2,13]);

```

```

S:=[1,2,13];
SS:=SN;
SSS:=Setseq(SS);
for i in [1 .. # SS] do
for g in IN do if ts[1]*ts[2]*ts[13]
eq g*ts[Rep(SSS[i])[1]]*ts[Rep(SSS[i])[2]]*ts[Rep(SSS[i])[3]]
then print SSS[i];
end if; end for; end for;
N1213s:=N1213;
# N1213s;
T1213:=Transversal(N,N1213s);
# T1213;
for i := 1 to # T1213 do
ss := [1, 2, 13]T1213[i];
cst[prodim(1, ts, ss)] := ss;
end for;
m:=0;
for i in [1 .. 672] do if cst[i] ne [ ]
then m:=m+1; end if; end for; m;
Orbits(N1213s);

N1214:=Stabiliser(N,[1,2,14]);
S:=[1,2,14];
SS:=SN;
SSS:=Setseq(SS);
for i in [1 .. # SS] do
for g in IN do if ts[1]*ts[2]*ts[14]
eq g*ts[Rep(SSS[i])[1]]*ts[Rep(SSS[i])[2]]*ts[Rep(SSS[i])[3]]
then print SSS[i];
end if; end for; end for;
N1214s:=N1214;

```

```

# N1214s;
T1214:=Transversal(N,N1214s);
# T1214;
for i := 1 to # T1214 do
ss := [1, 2, 14]T1214[i];
cst[prodim(1, ts, ss)] := ss;
end for;
m:=0;
for i in [1 .. 672] do if cst[i] ne [ ]
then m:=m+1; end if; end for; m;
Orbits(N1214s);

N1215:=Stabiliser(N,[1,2,15]);
S:=[1,2,15];
SS:=SN;
SSS:=Setseq(SS);
for i in [1 .. # SS] do
for g in IN do if ts[1]*ts[2]*ts[15]
eq g*ts[Rep(SSS[i])[1]]*ts[Rep(SSS[i])[2]]*ts[Rep(SSS[i])[3]]
then print SSS[i];
end if; end for; end for;
N1215s:=N1215;
# N1215s;
T1215:=Transversal(N,N1215s);
# T1215;
for i := 1 to # T1215 do
ss := [1, 2, 15]T1215[i];
cst[prodim(1, ts, ss)] := ss;
end for;
m:=0;
for i in [1 .. 672] do if cst[i] ne [ ]

```

```

then m:=m+1; end if; end for; m;
Orbits(N1215s);

N131:=Stabiliser(N,[1,3,1]);
S:=[1,3,1];
SS:=SN;
SSS:=Setseq(SS);
for i in [1 .. # SS] do
for g in IN do if ts[1]*ts[3]*ts[1]
eq g*ts[Rep(SSS[i])[1]]*ts[Rep(SSS[i])[2]]*ts[Rep(SSS[i])[3]]
then print SSS[i];
end if; end for; end for;
N131s:=N131;
# N131s;
T131:=Transversal(N,N131s);
# T131;
for i := 1 to # T131 do
ss := [1, 3, 1]T131[i];
cst[prodim(1, ts, ss)] := ss;
end for;
m:=0;
for i in [1 .. 672] do if cst[i] ne [ ]
then m:=m+1; end if; end for; m;
Orbits(N131s);
N132:=Stabiliser(N,[1,3,2]);
S:=[1,3,2]; SS:=SN;
SSS:=Setseq(SS);
for i in [1 .. # SS] do
for g in IN do if ts[1]*ts[3]*ts[2]
eq g*ts[Rep(SSS[i])[1]]*ts[Rep(SSS[i])[2]]*ts[Rep(SSS[i])[3]]
then print SSS[i];

```

```

end if; end for; end for;
N132s:=N132;
# N132s;
T132:=Transversal(N,N132s);
# T132;
for i := 1 to # T132 do
ss := [1, 3, 2]T132[i];
cst[prodim(1, ts, ss)] := ss;
end for;
m:=0;
for i in [1 .. 672] do if cst[i] ne [ ]
thenm:=m+1; end if; end for; m;
Orbits(N132s);

N134:=Stabiliser(N,[1,3,4]);
S:=[1,3,4];
SS:=SN;
SSS:=Setseq(SS);
for i in [1 .. # SS] do
for g in IN do if ts[1]*ts[3]*ts[4]
eq g*ts[Rep(SSS[i])[1]]*ts[Rep(SSS[i])[2]]*ts[Rep(SSS[i])[3]]
then print SSS[i];
end if; end for; end for;
N134s:=N134;
# N134s;
T134:=Transversal(N,N134s);
# T134;
T134:=Transversal(N,N134s);
for i := 1 to # T134 do
ss := [1, 3, 4]T134[i];
cst[prodim(1, ts, ss)] := ss;

```

```

end for;
m:=0;
for i in [1 .. 672] do if cst[i] ne [ ]
then m:=m+1; end if; end for; m;
Orbits(N134s);

N135:=Stabiliser(N,[1,3,5]);
S:=[1,3,5];
SS:=SN;
SSS:=Setseq(SS);
for i in [1 .. # SS] do
for g in IN do if ts[1]*ts[3]*ts[5]
eq g*ts[Rep(SSS[i])[1]]*ts[Rep(SSS[i])[2]]*ts[Rep(SSS[i])[3]]
then print SSS[i];
end if; end for; end for;
N135s:=N135;
# N135s;
T135:=Transversal(N,N135s);
# T135;
for i := 1 to #T135 do
ss := [1, 3, 5]T135[i];
cst[prodim(1, ts, ss)] := ss;
end for;
m:=0;
for i in [1 .. 672] do if cst[i] ne [ ]
then m:=m+1; end if; end for; m;
Orbits(N135s);
N136:=Stabiliser(N,[1,3,6]);
S:=[1,3,6];
SS:=SN;
SSS:=Setseq(SS);

```

```

for i in [1 .. # SS] do
for g in IN do if ts[1]*ts[3]*ts[6]
eq g*ts[Rep(SSS[i])[1]]*ts[Rep(SSS[i])[2]]*ts[Rep(SSS[i])[3]]
then print SSS[i];
end if; end for; end for;
N136s:=N136;
# N136s;
T136:=Transversal(N,N136s);
# T136;
for i := 1 to # T136 do
ss := [1, 3, 6]T136[i];
cst[prodim(1, ts, ss)] := ss;
end for;
m:=0;
for i in [1 .. 672] do if cst[i] ne [ ]
then m:=m+1; end if; end for; m;
Orbits(N136s);

N137:=Stabiliser(N,[1,3,7]);
S:=[1,3,7];
SS:=SN;
SSS:=Setseq(SS);
for i in [1 .. # SS] do
for g in IN do if ts[1]*ts[3]*ts[7]
eq g*ts[Rep(SSS[i])[1]]*ts[Rep(SSS[i])[2]]*ts[Rep(SSS[i])[3]]
then print SSS[i];
end if; end for; end for;
N137s:=N137;
# N137s;
T137:=Transversal(N,N137s);
# T137;

```



```

for i := 1 to # T137 do
ss := [1, 3, 7]T137[i];
cst[prodim(1, ts, ss)] := ss;
end for;
m:=0;
for i in [1 .. 672] do if cst[i] ne [ ]
then m:=m+1; end if; end for; m;
Orbits(N137s);

N138:=Stabiliser(N,[1,3,8]);
S:=[1,3,8];
SS:=SN;
SSS:=Setseq(SS);
for i in [1 .. # SS] do
for g in IN do if ts[1]*ts[3]*ts[8]
eq g*ts[Rep(SSS[i])[1]]*ts[Rep(SSS[i])[2]]*ts[Rep(SSS[i])[3]]
then print SSS[i];
end if; end for; end for;
N138s:=N138;
# N138s;
T138:=Transversal(N,N138s);
# T138;
for i := 1 to # T138 do ss := [1, 3, 8]T138[i];
cst[prodim(1, ts, ss)] := ss;
end for;
m:=0;
for i in [1 .. 672] do if cst[i] ne [ ] then
m:=m+1; end if; end for; m;
Orbits(N138s);

N139:=Stabiliser(N,[1,3,9]);

```

```

S:=[1,3,9];
SS:=SN;
SSS:=Setseq(SS);
for i in [1 .. # SS] do
for g in IN do if ts[1]*ts[3]*ts[9]
eq g*ts[Rep(SSS[i])[1]]*ts[Rep(SSS[i])[2]]*ts[Rep(SSS[i])[3]]
then print SSS[i];
end if; end for; end for;
N139s:=N139;
# N139s;
T139:=Transversal(N,N139s);
# T139;
for i := 1 to # T139 do
ss := [1, 3, 9]T139[i];
cst[prodim(1, ts, ss)] := ss;
end for;
m:=0;
for i in [1 .. 672] do if cst[i] ne [ ]
then m:=m+1; end if; end for; m;
Orbits(N139s);

N1310:=Stabiliser(N,[1,3,10]);
S:=[1,3,10];
SS:=SN;
SSS:=Setseq(SS); for i in [1 .. # SS] do
for g in IN do if ts[1]*ts[3]*ts[10]
eq g*ts[Rep(SSS[i])[1]]*ts[Rep(SSS[i])[2]]*ts[Rep(SSS[i])[3]]
then print SSS[i];
end if; end for; end for;
N1310s:=N1310;
# N1310s;

```

```

T1310:=Transversal(N,N1310s);
# T1310;
for i := 1 to # T1310 do
ss := [1, 3, 10]T1310[i];
cst[prodim(1, ts, ss)] := ss;
end for;
m:=0;
for i in [1 .. 672] do if cst[i] ne [ ]
then m:=m+1; end if; end for; m;
Orbits(N1310s);

N1311:=Stabiliser(N,[1,3,11]);
S:=[1,3,11];
SS:=SN;
SSS:=Setseq(SS);
for i in [1 .. # SS] do
for g in IN do if ts[1]*ts[3]*ts[11]
eq g*ts[Rep(SSS[i])[1]]*ts[Rep(SSS[i])[2]]*ts[Rep(SSS[i])[3]]
then print SSS[i];
end if; end for; end for;
N1311s:=N1311;
# N1311s;
T1311:=Transversal(N,N1311s);
# T1311;
for i := 1 to # T1311 do
ss := [1, 3, 11]T1311[i];
cst[prodim(1, ts, ss)] := ss;
end for;
m:=0;
for i in [1 .. 672] do if cst[i] ne [ ]
then m:=m+1; end if; end for; m;

```

```

Orbits(N1311s);

N1312:=Stabiliser(N,[1,3,12]);
S:=[1,3,12];
SS:=SN;
SSS:=Setseq(SS);
for i in [1 .. # SS] do
for g in IN do if ts[1]*ts[3]*ts[12]
eq g*ts[Rep(SSS[i])[1]]*ts[Rep(SSS[i])[2]]*ts[Rep(SSS[i])[3]]
then print SSS[i];
end if; end for; end for;
N1312s:=N1312;
# N1312s;
T1312:=Transversal(N,N1312s);
# T1312;
for i := 1 to # T1312 do
ss := [1, 3, 12]TT1312[i];
cst[prodim(1, ts, ss)] := ss;
end for;
m:=0;
for i in [1 .. 672] do if cst[i] ne [ ]
then m:=m+1; end if; end for; m;
Orbits(N1312s);

N1313:=Stabiliser(N,[1,3,13]);
S:=[1,3,13];
SS:=SN;
SSS:=Setseq(SS);
for i in [1 .. # SS] do
for g in IN do if ts[1]*ts[3]*ts[13]
eq g*ts[Rep(SSS[i])[1]]*ts[Rep(SSS[i])[2]]*ts[Rep(SSS[i])[3]]

```

```

then print SSS[i];
end if; end for; end for;
N1313s:=N1313;
# N1313s;
T1313:=Transversal(N,N1313s);
# T1313;
for i := 1 to # T1313 do
ss := [1, 3, 13]T1313[i];
cst[prodim(1, ts, ss)] := ss;
end for;
m:=0;
for i in [1 .. 672] do if cst[i] ne [ ]
then m:=m+1; end if; end for; m;
Orbits(N1313s);

N1314:=Stabiliser(N,[1,3,14]);
S:=[1,3,14];
SS:=SN;
SSS:=Setseq(SS);
for i in [1 .. # SS] do
for g in IN do if ts[1]*ts[3]*ts[14]
eq g*ts[Rep(SSS[i])[1]]*ts[Rep(SSS[i])[2]]*ts[Rep(SSS[i])[3]]
then print SSS[i];
end if; end for; end for;
N1314s:=N1314;
# N1314s;
T1314:=Transversal(N,N1314s);
# T1314;
for i := 1 to # T1314 do
ss := [1, 3, 14]T1314[i];
cst[prodim(1, ts, ss)] := ss;

```

```

end for;
m:=0;
for i in [1 .. 672] do if cst[i] ne [ ] then
m:=m+1; end if; end for; m;
Orbits(N1314s);

N1315:=Stabiliser(N,[1,3,15]);
S:=[1,3,15];
SS:=SN;
SSS:=Setseq(SS);
for i in [1 .. # SS] do
for g in IN do if ts[1]*ts[3]*ts[15]
eq g*ts[Rep(SSS[i])[1]]*ts[Rep(SSS[i])[2]]*ts[Rep(SSS[i])[3]]
then print SSS[i];
N1315s:=N1315;
# N1315s;
T1315:=Transversal(N,N1315s);
# T1315;
for i := 1 to # T1315 do
ss := [1, 3, 15]T1315[i];
cst[prodim(1, ts, ss)] := ss;
end for;
m:=0;
for i in [1 .. 672] do if cst[i] ne [ ]
then m:=m+1; end if; end for; m;
Orbits(N1315s);

S:=[1,2,1,2];
SS:=SN;
SSS:=Setseq(SS);
for i in [1 .. # SS] do

```

```

for g in IN do if ts[1]*ts[2]*ts[1]*ts[2]
eq g*ts[Rep(SSS[i])[1]]*ts[Rep(SSS[i])[2]]
*ts[Rep(SSS[i])[3]]*ts[Rep(SSS[i])[4]]
then print SSS[i];
end if; end for; end for;
N1212s:=N1212;
# N1212s;
T1212:=Transversal(N,N1212s);
# T1212;
for i := 1 to # T1212 do
ss := [1, 2, 1, 2]T1212[i];
cst[prodim(1, ts, ss)] := ss;
end for;
m:=0;
for i in [1 .. 672] do if cst[i] ne [ ]
then m:=m+1; end if; end for; m;
Orbits(N1212s);

N1213:=Stabiliser(N,[1,2,1,3]);
S:=[1,2,1,3];
SS:=SN;
SSS:=Setseq(SS);
for i in [1 .. # SS] do
for g in IN do if ts[1]*ts[2]*ts[1]*ts[3]
eq g*ts[Rep(SSS[i])[1]]*ts[Rep(SSS[i])[2]]
*ts[Rep(SSS[i])[3]]*ts[Rep(SSS[i])[4]]
then print SSS[i];
end if; end for; end for;
N1213s:=N1213;
# N1213s;
T1213:=Transversal(N,N1213s);

```

```

# T1213;
for i := 1 to # T1213 do
ss := [1, 2, 1, 3]T1213[i];
cst[prodim(1, ts, ss)] := ss;
end for;
m:=0;
for i in [1 .. 672] do if cst[i] ne [ ]
then m:=m+1; end if; end for; m;
Orbits(N1213s);

N1214:=Stabiliser(N,[1,2,1,4]);
S:=[1,2,1,4];
SS:=SN;
SSS:=Setseq(SS);
for i in [1 .. # SS] do
for g in IN do if ts[1]*ts[2]*ts[1]*ts[4]
eq g*ts[Rep(SSS[i])[1]]*ts[Rep(SSS[i])[2]]
*ts[Rep(SSS[i])[3]]*ts[Rep(SSS[i])[4]]
then print SSS[i];
end if; end for; end for;
N1214s:=N1214;
# N1214s;
T1214:=Transversal(N,N1214s);
# T1214;
for i := 1 to # T1214 do
ss := [1, 2, 1, 4]T1214[i];
cst[prodim(1, ts, ss)] := ss;
end for;
m:=0;
for i in [1 .. 672] do if cst[i] ne [ ]
then m:=m+1; end if; end for; m;

```



```

Orbits(N1214s);

N1215:=Stabiliser(N,[1,2,1,5]);
S:=[1,2,1,5];
SS:=SN;
SSS:=Setseq(SS);
for i in [1 .. # SS] do
for g in IN do if ts[1]*ts[2]*ts[1]*ts[5]
eq g*ts[Rep(SSS[i])[1]]*ts[Rep(SSS[i])[2]]
*ts[Rep(SSS[i])[3]]*ts[Rep(SSS[i])[4]]
then print SSS[i];
end if; end for; end for;
N1215s:=N1215;
# N1215s;
T1215:=Transversal(N,N1215s);
# T1215;
for i := 1 to # T1215 do
ss := [1, 2, 1, 5]T1215[i];
cst[prodim(1, ts, ss)] := ss;
end for;
m:=0;
for i in [1 .. 672] do if cst[i] ne [ ]
then m:=m+1; end if; end for; m;
Orbits(N1215s);

N1216:=Stabiliser(N,[1,2,1,6]);
S:=[1,2,1,6];
SS:=SN;
SSS:=Setseq(SS);
for i in [1 .. # SS] do
for g in IN do if ts[1]*ts[2]*ts[1]*ts[6]

```

```

eq g*ts[Rep(SSS[i])[1]]*ts[Rep(SSS[i])[2]]
*ts[Rep(SSS[i])[3]]*ts[Rep(SSS[i])[4]]
then print SSS[i];
end if; end for; end for;
N1216s:=N1216;
# N1216s;
T1216:=Transversal(N,N1216s);
# T1216;
for i := 1 to # T1216 do
ss := [1, 2, 1, 6]T1216[i];
cst[prodim(1, ts, ss)] := ss;
end for;
m:=0;
for i in [1 .. 672] do if cst[i] ne [ ]
then m:=m+1; end if; end for; m;
Orbits(N1216s);

N1217:=Stabiliser(N,[1,2,1,7]);
S:=[1,2,1,7];
SS:=SN;
SSS:=Setseq(SS);
for i in [1..# SS] do
for g in IN do if ts[1]*ts[2]*ts[1]*ts[7]
eq g*ts[Rep(SSS[i])[1]]*ts[Rep(SSS[i])[2]]
*ts[Rep(SSS[i])[3]]*ts[Rep(SSS[i])[4]]
then print SSS[i];
end if; end for; end for;
N1217s:=N1217;
# N1217s;
T1217:=Transversal(N,N1217s);
# T1217;

```

```

for i := 1 to # T1217 do
ss := [1, 2, 1, 7]T1217[i];
cst[prodim(1, ts, ss)] := ss;
end for;
m:=0;
for i in [1 .. 672] do if cst[i] ne [ ]
then m:=m+1; end if; end for; m;
Orbits(N1217s);

N1218:=Stabiliser(N,[1,2,1,8]);
S:=[1,2,1,8];
SS:=SN;
SSS:=Setseq(SS);
for i in [1 .. # SS] do
for g in IN do if ts[1]*ts[2]*ts[1]*ts[8]
eq g*ts[Rep(SSS[i])[1]]*ts[Rep(SSS[i])[2]]
*ts[Rep(SSS[i])[3]]*ts[Rep(SSS[i])[4]]
then print SSS[i];
end if; end for; end for;
N1218s:=N1218;
# N1218s;
T1218:=Transversal(N,N1218s);
# T1218;
for i := 1 to # T1218 do
ss := [1, 2, 1, 8]T1218[i];
cst[prodim(1, ts, ss)] := ss;
end for;
m:=0;
for i in [1 .. 672] do if cst[i] ne [ ]
then m:=m+1; end if; end for; m;
Orbits(N1218s);

```

```

N1219:=Stabiliser(N,[1,2,1,9]);
S:=[1,2,1,9];
SS:=S^N;
SSS:=Setseq(SS);
for i in [1 .. # SS] do
for g in IN do if ts[1]*ts[2]*ts[1]*ts[9]
eq g*ts[Rep(SSS[i])[1]]*ts[Rep(SSS[i])[2]]
*ts[Rep(SSS[i])[3]]*ts[Rep(SSS[i])[4]]
then print SSS[i];
end if; end for; end for;
N1219s:=N1219;
# N1219s;
T1219:=Transversal(N,N1219s);
# T1219;
for i := 1 to # T1219 do
ss := [1, 2, 1, 9]^T1219[i];
cst[prodim(1, ts, ss)] := ss;
end for;
m:=0;
for i in [1 .. 672] do if cst[i] ne [ ]
then m:=m+1; end if; end for; m;
Orbits(N1219s);

N12110:=Stabiliser(N,[1,2,1,10]);
S:=[1,2,1,10];
SS:=S^N;
SSS:=Setseq(SS);
for i in [1 .. # SS] do
for g in IN do if ts[1]*ts[2]*ts[1]*ts[10]
eq g*ts[Rep(SSS[i])[1]]*ts[Rep(SSS[i])[2]]

```

```

*ts[Rep(SSS[i])[3]]*ts[Rep(SSS[i])[4]]
then print SSS[i];
end if; end for; end for;
N12110s:=N12110;
# N12110s;
T12110:=Transversal(N,N12110s);
# T12110;
for i := 1 to # T12110 do
ss := [1, 2, 1, 10]T12110[i];
cst[prodim(1, ts, ss)] := ss;
end for;
m:=0;
for i in [1 .. 672] do if cst[i] ne [ ]
then m:=m+1; end if; end for; m;
Orbits(N12110s);

N12111:=Stabiliser(N,[1,2,1,11]);
S:=[1,2,1,11];
SS:=SN;
SSS:=Setseq(SS);
for i in [1 .. # SS] do
for g in IN do if ts[1]*ts[2]*ts[1]*ts[11]
eq g*ts[Rep(SSS[i])[1]]*ts[Rep(SSS[i])[2]]
*ts[Rep(SSS[i])[3]]*ts[Rep(SSS[i])[4]]
then print SSS[i];
end if; end for; end for;
N12111s:=N12111;
# N12111s;
T12111:=Transversal(N,N12111s);
# T12111;
for i := 1 to # T12111 do

```

```

ss := [1, 2, 1, 11]T12111[i];
cst[prodim(1, ts, ss)] := ss;
end for;
m:=0;
for i in [1 .. 672] do if cst[i] ne [ ]
then m:=m+1; end if; end for; m;
Orbits(N12111s);

N12112:=Stabiliser(N,[1,2,1,12]);
S:=[1,2,1,12];
SS:=SN;
SSS:=Setseq(SS);
for i in [1 .. # SS] do
for g in IN do if ts[1]*ts[2]*ts[1]*ts[12]
eq g*ts[Rep(SSS[i])[1]]*ts[Rep(SSS[i])[2]]
*ts[Rep(SSS[i])[3]]*ts[Rep(SSS[i])[4]]
then print SSS[i];
end if; end for; end for;
N12112s:=N12112;
# N12112s;
T12112:=Transversal(N,N12112s);
# T12112;
for i := 1 to # T12112 do
ss := [1, 2, 1, 12]T12112[i];
cst[prodim(1, ts, ss)] := ss;
end for;
m:=0;
for i in [1 .. 672] do if cst[i] ne [ ]
then m:=m+1; end if; end for; m;
Orbits(N12112s);

```

```

N12113:=Stabiliser(N,[1,2,1,13]);
S:=[1,2,1,13];
SS:=SN;
SSS:=Setseq(SS);
for i in [1 .. # SS] do
for g in IN do if ts[1]*ts[2]*ts[1]*ts[13]
eq g*ts[Rep(SSS[i])[1]]*ts[Rep(SSS[i])[2]]
*ts[Rep(SSS[i])[3]]*ts[Rep(SSS[i])[4]]
then print SSS[i];
end if; end for; end for;
N12113s:=N12113;
# N12113s;
T12113:=Transversal(N,N12113s);
# T12113;
for i := 1 to # T12113 do
ss := [1, 2, 1, 13]T12113[i];
cst[prodim(1, ts, ss)] := ss;
end for;
m:=0;
for i in [1 .. 672] do if cst[i] ne [ ]
then m:=m+1; end if; end for; m;
Orbits(N12113s);

N12114:=Stabiliser(N,[1,2,1,14]);
S:=[1,2,1,14];
SS:=SN;
SSS:=Setseq(SS);
for i in [1 .. # SS] do
for g in IN do if ts[1]*ts[2]*ts[1]*ts[14]
eq g*ts[Rep(SSS[i])[1]]*ts[Rep(SSS[i])[2]]
*ts[Rep(SSS[i])[3]]*ts[Rep(SSS[i])[4]]

```

```

then print SSS[i];
end if; end for; end for;
N12114s:=N12114;
# N12114s;
T12114:=Transversal(N,N12114s);
# T12114;
for i := 1 to # T12114 do
ss := [1, 2, 1, 14]T12114[i];
cst[prodim(1, ts, ss)] := ss;
end for;
m:=0;
for i in [1 .. 672] do if cst[i] ne [ ]
then m:=m+1; end if; end for; m;
Orbits(N12114s);

N12115:=Stabiliser(N,[1,2,1,15]);
S:=[1,2,1,15];
SS:=SN;
SSS:=Setseq(SS);
for i in [1 .. # SS] do
for g in IN do if ts[1]*ts[2]*ts[1]*ts[15]
eq g*ts[Rep(SSS[i])[1]]*ts[Rep(SSS[i])[2]]
*ts[Rep(SSS[i])[3]]*ts[Rep(SSS[i])[4]]
then print SSS[i];
end if; end for; end for;
N12115s:=N12115;
# N12115s;
T12115:=Transversal(N,N12115s);
# T12115;
for i := 1 to # T12115 do
ss := [1, 2, 1, 15]T12115[i];

```



```

cst[prodim(1, ts, ss)] := ss;
end for;
m:=0;
for i in [1 .. 672] do if cst[i] ne [ ]
then m:=m+1; end if; end for; m;
Orbits(N12115s);

N1241:=Stabiliser(N,[1,2,4,1]);
S:=[1,2,4,1];
SS:=SN;
SSS:=Setseq(SS);
for i in [1 .. # SS] do
for g in IN do if ts[1]*ts[2]*ts[4]*ts[1]
eq g*ts[Rep(SSS[i])[1]]*ts[Rep(SSS[i])[2]]
*ts[Rep(SSS[i])[3]]*ts[Rep(SSS[i])[4]]
then print SSS[i];
end if; end for; end for;
N1241s:=N1241;
# N1241s;
T1241:=Transversal(N,N1241s);
# T1241;
for i := 1 to # T1241 do
ss := [1, 2, 4, 1]T1241[i];
cst[prodim(1, ts, ss)] := ss;
end for;
m:=0;
for i in [1 .. 672] do if cst[i] ne [ ]
then m:=m+1; end if; end for; m;
Orbits(N1241s);

N1242:=Stabiliser(N,[1,2,4,2]);

```

```

S:=[1,2,4,2];
SS:=SN;
SSS:=Setseq(SS);
for i in [1 .. # SS] do
for g in IN do if ts[1]*ts[2]*ts[4]*ts[2]
eq g*ts[Rep(SSS[i])[1]]*ts[Rep(SSS[i])[2]]
*ts[Rep(SSS[i])[3]]*ts[Rep(SSS[i])[4]]
then print SSS[i];
end if; end for; end for;
N1242s:=N1242;
# N1242s;
T1242:=Transversal(N,N1242s);
# T1242;
for i := 1 to # T1242 do
ss := [1, 2, 4, 2]T1242[i];
cst[prodim(1, ts, ss)] := ss;
end for;
m:=0;
for i in [1 .. 672] do if cst[i] ne [ ]
then m:=m+1; end if; end for; m;
Orbits(N1242s);

N1243:=Stabiliser(N,[1,2,4,3]);
S:=[1,2,4,3];
SS:=SN;
SSS:=Setseq(SS);
for i in [1 .. # SS] do
for g in IN do if ts[1]*ts[2]*ts[4]*ts[3]
eq g*ts[Rep(SSS[i])[1]]*ts[Rep(SSS[i])[2]]
*ts[Rep(SSS[i])[3]]*ts[Rep(SSS[i])[4]]
then print SSS[i];

```

```

end if; end for; end for;
N1243s:=N1243;
# N1243s;
T1243:=Transversal(N,N1243s);
# T1243;
for i := 1 to # T1243 do
ss := [1, 2, 4, 3]T1243[i];
cst[prodim(1, ts, ss)] := ss;
end for;
m:=0;
for i in [1 .. 672] do if cst[i] ne [ ]
then m:=m+1; end if; end for; m;
Orbits(N1243s);

N1245:=Stabiliser(N,[1,2,4,5]);
S:=[1,2,4,5];
SS:=SN;
SSS:=Setseq(SS);
for i in [1 .. # SSS] do
for g in IN do if ts[1]*ts[2]*ts[4]*ts[5]
eq g*ts[Rep(SSS[i])[1]]*ts[Rep(SSS[i])[2]]
*ts[Rep(SSS[i])[3]]*ts[Rep(SSS[i])[4]]
then print SSS[i];
end if; end for; end for;
N1245s:=N1245;
# N1245s;
T1245:=Transversal(N,N1245s);
# T1245;
for i := 1 to # T1245 do
ss := [1, 2, 4, 5]T1245[i];
cst[prodim(1, ts, ss)] := ss;

```

```

end for;
m:=0;
for i in [1 .. 672] do if cst[i] ne [ ]
then m:=m+1; end if; end for; m;
Orbits(N1245s);

N1246:=Stabiliser(N,[1,2,4,6]);
S:=[1,2,4,6];
SS:=SN;
SSS:=Setseq(SS);
for i in [1 .. # SS] do
for g in IN do if ts[1]*ts[2]*ts[4]*ts[6]
eq g*ts[Rep(SSS[i])[1]]*ts[Rep(SSS[i])[2]]
*ts[Rep(SSS[i])[3]]*ts[Rep(SSS[i])[4]]
then print SSS[i];
end if; end for; end for;
N1246s:=N1246;
# N1246s;
T1246:=Transversal(N,N1246s);
# T1246;
for i := 1 to #T1246 do
ss := [1, 2, 4, 6]T1246[i];
cst[prodim(1, ts, ss)] := ss;
end for;
m:=0;
for i in [1 .. 672] do if cst[i] ne [ ]
then m:=m+1; end if; end for; m;
Orbits(N1246s);

N1247:=Stabiliser(N,[1,2,4,7]);
S:=[1,2,4,7];

```

```

SS:=SN;
SSS:=Setseq(SS);
for i in [1 .. # SS] do
for g in IN do if ts[1]*ts[2]*ts[4]*ts[7]
eq g*ts[Rep(SSS[i])[1]]*ts[Rep(SSS[i])[2]]
*ts[Rep(SSS[i])[3]]*ts[Rep(SSS[i])[4]]
then print SSS[i];
end if; end for; end for;
N1247s:=N1247;
#N1247s;
T1247:=Transversal(N,N1247s);
# T1247;
for i := 1 to # T1247 do
ss := [1, 2, 4, 7]T1247[i];
cst[prodim(1, ts, ss)] := ss;
end for;
m:=0;
for i in [1 .. 672] do if cst[i] ne [ ]
then m:=m+1; end if; end for; m; Orbits(N1247s);

N1248:=Stabiliser(N,[1,2,4,8]);
S:=[1,2,4,8];
SS:=SN;
SSS:=Setseq(SS);
for i in [1..# SS] do
for g in IN do if ts[1]*ts[2]*ts[4]*ts[8]
eq g*ts[Rep(SSS[i])[1]]*ts[Rep(SSS[i])[2]]
*ts[Rep(SSS[i])[3]]*ts[Rep(SSS[i])[4]]
then print SSS[i];
end if; end for; end for;
N1248s:=N1248;

```

```

# N1248s;
T1248:=Transversal(N,N1248s);
# T1248;
for i := 1 to # T1248 do
ss := [1, 2, 4, 8]T1248[i];
cst[prodim(1, ts, ss)] := ss;
end for;
m:=0;
for i in [1 .. 672] do if cst[i] ne [ ]
then m:=m+1; end if; end for; m;
Orbits(N1248s);

N1249:=Stabiliser(N,[1,2,4,9]);
S:=[1,2,4,9];
SS:=SN;
SSS:=Setseq(SS);
for i in [1 .. # SS] do
for g in IN do if ts[1]*ts[2]*ts[4]*ts[9]
eq g*ts[Rep(SSS[i])[1]]*ts[Rep(SSS[i])[2]]
*ts[Rep(SSS[i])[3]]*ts[Rep(SSS[i])[4]]
then print SSS[i];
end if; end for; end for;
N1249s:=N1249;
# N1249s;
T1249:=Transversal(N,N1249s);
# T1249;
for i := 1 to # T1249 do
ss := [1, 2, 4, 9]T1249[i];
cst[prodim(1, ts, ss)] := ss;
end for;
m:=0;

```

```

for i in [1 .. 672] do if cst[i] ne [ ]
then m:=m+1; end if; end for; m;
Orbits(N1249s);

N12410:=Stabiliser(N,[1,2,4,10]);
S:=[1,2,4,10];
SS:=SN;
SSS:=Setseq(SS);
for i in [1 .. # SS] do
for g in IN do if ts[1]*ts[2]*ts[4]*ts[10]
eq g*ts[Rep(SSS[i])[1]]*ts[Rep(SSS[i])[2]]
*ts[Rep(SSS[i])[3]]*ts[Rep(SSS[i])[4]]
then print SSS[i];
end if; end for; end for;
N12410s:=N12410;
# N12410s;
T12410:=Transversal(N,N12410s);
# T12410;
for i := 1 to # T12410 do
ss := [1, 2, 4, 10]T12410[i];
cst[prodim(1, ts, ss)] := ss;
end for;
m:=0;
for i in [1 .. 672] do if cst[i] ne [ ]
then m:=m+1; end if; end for; m;
Orbits(N12410s);

N12411:=Stabiliser(N,[1,2,4,11]);
S:=[1,2,4,11];
SS:=SN;
SSS:=Setseq(SS);

```

```

for i in [1 .. # SS] do
for g in IN do if ts[1]*ts[2]*ts[4]*ts[11]
eq g*ts[Rep(SSS[i])[1]]*ts[Rep(SSS[i])[2]]
*ts[Rep(SSS[i])[3]]*ts[Rep(SSS[i])[4]]
then print SSS[i];
end if; end for; end for;
N12411s:=N12411;
# N12411s;
T12411:=Transversal(N,N12411s);
# T12411;
for i := 1 to # T12411 do
ss := [1, 2, 4, 11]T12411[i];
cst[prodim(1, ts, ss)] := ss;
end for;
m:=0;
for i in [1 .. 672] do if cst[i] ne [ ]
then m:=m+1; end if; end for; m;
Orbits(N12411s);

N12412:=Stabiliser(N,[1,2,4,12]);
S:=[1,2,4,12];
SS:=SN;
SSS:=Setseq(SS);
for i in [1 .. # SS] do
for g in IN do if ts[1]*ts[2]*ts[4]*ts[12]
eq g*ts[Rep(SSS[i])[1]]*ts[Rep(SSS[i])[2]]
*ts[Rep(SSS[i])[3]]*ts[Rep(SSS[i])[4]]
then print SSS[i];
end if; end for; end for;
N12412s:=N12412;
# N12412s;

```



```

T12412:=Transversal(N,N12412s);
# T12412;
for i := 1 to # T12412 do
ss := [1, 2, 4, 12]T12412[i];
cst[prodim(1, ts, ss)] := ss;
end for;
m:=0;
for i in [1 .. 672] do if cst[i] ne [ ]
then m:=m+1; end if; end for; m;
Orbits(N12412s);

N12413:=Stabiliser(N,[1,2,4,13]);
S:=[1,2,4,13];
SS:=SN;
SSS:=Setseq(SS);
for i in [1 .. # SS] do
for g in IN do if ts[1]*ts[2]*ts[4]*ts[13]
eq g*ts[Rep(SSS[i])[1]]*ts[Rep(SSS[i])[2]]
*ts[Rep(SSS[i])[3]]*ts[Rep(SSS[i])[4]]
then print SSS[i];
end if; end for; end for;
N12413s:=N12413;
# N12413s;
T12413:=Transversal(N,N12413s);
# T12413;
for i := 1 to #T12413 do
ss := [1, 2, 4, 13]T12413[i];
cst[prodim(1, ts, ss)] := ss;
end for;
m:=0;
for i in [1 .. 672] do if cst[i] ne [ ]

```

```

then m:=m+1; end if; end for; m;
Orbits(N12413s);

12414:=Stabiliser(N,[1,2,4,14]);
S:=[1,2,4,14];
SS:=SN;
SSS:=Setseq(SS);
for i in [1 .. # SS] do
for g in IN do if ts[1]*ts[2]*ts[4]*ts[14]
eq g*ts[Rep(SSS[i])[1]]*ts[Rep(SSS[i])[2]]
*ts[Rep(SSS[i])[3]]*ts[Rep(SSS[i])[4]]
then print SSS[i];
end if; end for; end for;
N12414s:=N12414;
# N12414s;
T12414:=Transversal(N,N12414s);
# T12414;
for i := 1 to # T12414 do
ss := [1, 2, 4, 14]T12414[i];
cst[prod(1, ts, ss)] := ss;
end for;
m:=0;
for i in [ 1 .. 672] do if cst[i] ne [ ]
then m:=m+1; end if; end for; m;
Orbits(N12414s);

N12415:=Stabiliser(N,[1,2,4,15]);
S:=[1,2,4,15];
SS:=SN;
SSS:=Setseq(SS);
for i in [1 .. # SS] do

```

```

for g in IN do if ts[1]*ts[2]*ts[4]*ts[15]
eq g*ts[Rep(SSS[i])[1]]*ts[Rep(SSS[i])[2]]
*ts[Rep(SSS[i])[3]]*ts[Rep(SSS[i])[4]]
then print SSS[i];
end if; end for; end for;
N12415s:=N12415;
# N12415s;
T12415:=Transversal(N,N12415s);
# T12415;
for i := 1 to # T12415 do
ss := [1, 2, 4, 15]T12415[i];
cst[prodim(1, ts, ss)] := ss;
end for;
m:=0;
for i in [1 .. 672] do if cst[i] ne [ ]
then m:=m+1; end if; end for; m;
Orbits(N12415s);

N1281:=Stabiliser(N,[1,2,8,1]);
S:=[1,2,8,1];
SS:=SN;
SSS:=Setseq(SS);
for i in [1 .. # SS] do
for g in IN do if ts[1]*ts[2]*ts[8]*ts[1]
eq g*ts[Rep(SSS[i])[1]]*ts[Rep(SSS[i])[2]]
*ts[Rep(SSS[i])[3]]*ts[Rep(SSS[i])[4]]
then print SSS[i];
end if; end for; end for;
N1281s:=N1281;
# N1281s;
T1281:=Transversal(N,N1281s);

```

```

# T1281;
for i := 1 to # T1281 do
ss := [1, 2, 8, 1]T1281[i];
cst[prodim(1, ts, ss)] := ss;
end for;
m:=0;
for i in [1 .. 672] do if cst[i] ne [ ]
then m:=m+1; end if; end for; m;
Orbits(N1281s);

N1282:=Stabiliser(N,[1,2,8,2]);
S:=[1,2,8,2];
SS:=SN;
SSS:=Setseq(SS);
for i in [1 .. # SS] do
for g in IN do if ts[1]*ts[2]*ts[8]*ts[2]
eq g*ts[Rep(SSS[i])[1]]*ts[Rep(SSS[i])[2]]
*ts[Rep(SSS[i])[3]]*ts[Rep(SSS[i])[4]]
then print SSS[i];
end if; end for; end for;
N1282s:=N1282;
# N1282s;
T1282:=Transversal(N,N1282s);
# T1282;
for i := 1 to # T1282 do
ss := [1, 2, 8, 2]T1282[i];
cst[prodim(1, ts, ss)] := ss;
end for;
m:=0;
for i in [1 .. 672] do if cst[i] ne [ ]
then m:=m+1; end if; end for; m;

```

```

Orbits(N1282s);

N1283:=Stabiliser(N,[1,2,8,3]);
S:=[1,2,8,3];
SS:=SN;
SSS:=Setseq(SS);
for i in [1 .. # SS] do
for g in IN do if ts[1]*ts[2]*ts[8]*ts[3]
eq g*ts[Rep(SSS[i])[1]]*ts[Rep(SSS[i])[2]]
*ts[Rep(SSS[i])[3]]*ts[Rep(SSS[i])[4]]
then print SSS[i];
end if; end for; end for;
N1283s:=N1283;
# N1283s;
T1283:=Transversal(N,N1283s);
# T1283;
for i := 1 to # T1283 do
ss := [1, 2, 8, 3]T1283[i];
cst[prodim(1, ts, ss)] := ss;
end for;
m:=0;
for i in [1 .. 672] do if cst[i] ne [ ]
then m:=m+1; end if; end for; m;
Orbits(N1283s);

N1284:=Stabiliser(N,[1,2,8,4]);
S:=[1,2,8,4];
SS:=SN;
SSS:=Setseq(SS);
for i in [1 .. # SS] do
for g in IN do if ts[1]*ts[2]*ts[8]*ts[4]

```

```

eq g*ts[Rep(SSS[i])[1]]*ts[Rep(SSS[i])[2]]
*ts[Rep(SSS[i])[3]]*ts[Rep(SSS[i])[4]]
then print SSS[i];
end if; end for; end for;
N1284s:=N1284;
# N1284s;
T1284:=Transversal(N,N1284s);
# T1284;
for i := 1 to # T1284 do
ss := [1, 2, 8, 4]T1284[i];
cst[prodim(1, ts, ss)] := ss;
end for;
m:=0;
for i in [1 .. 672] do if cst[i] ne [ ]
then m:=m+1; end if; end for; m;
Orbits(N1284s);

N1285:=Stabiliser(N,[1,2,8,5]);
S:=[1,2,8,5];
SS:=SN;
SSS:=Setseq(SS);
for i in [1 .. # SS] do
for g in IN do if ts[1]*ts[2]*ts[8]*ts[5]
eq g*ts[Rep(SSS[i])[1]]*ts[Rep(SSS[i])[2]]
*ts[Rep(SSS[i])[3]]*ts[Rep(SSS[i])[4]]
then print SSS[i];
end if; end for; end for;
N1285s:=N1285;
# N1285s;
T1285:=Transversal(N,N1285s);
# T1285;

```

```

for i := 1 to # T1285 do
ss := [1, 2, 8, 5]T1285[i];
cst[prodim(1, ts, ss)] := ss;
end for;
m:=0;
for i in [1 .. 672] do if cst[i] ne [ ]
then m:=m+1; end if; end for; m;
Orbits(N1285s);

N1286:=Stabiliser(N,[1,2,8,6]);
S:=[1,2,8,6];
SS:=SN;
SSS:=Setseq(SS);
for i in [1 .. # SS] do
for g in IN do if ts[1]*ts[2]*ts[8]*ts[6]
eq g*ts[Rep(SSS[i])[1]]*ts[Rep(SSS[i])[2]]
*ts[Rep(SSS[i])[3]]*ts[Rep(SSS[i])[4]]
then print SSS[i];
end if; end for; end for;
N1286s:=N1286;
# N1286s;
T1286:=Transversal(N,N1286s);
# T1286;
for i := 1 to # T1286 do
ss := [1, 2, 8, 6]T1286[i];
cst[prodim(1, ts, ss)] := ss;
end for;
m:=0;
for i in [1 .. 672] do if cst[i] ne [ ]
then m:=m+1; end if; end for; m;
Orbits(N1286s);

```

```

N1287:=Stabiliser(N,[1,2,8,7]);
S:=[1,2,8,7];
SS:=S^N;
SSS:=Setseq(SS);
for i in [1 .. # SS] do
for g in IN do if ts[1]*ts[2]*ts[8]*ts[7]
eq g*ts[Rep(SSS[i])[1]]*ts[Rep(SSS[i])[2]]
*ts[Rep(SSS[i])[3]]*ts[Rep(SSS[i])[4]]
then print SSS[i];
end if; end for; end for;
N1287s:=N1287;
# N1287s;
T1287:=Transversal(N,N1287s);
# T1287;
for i := 1 to # T1287 do
ss := [1, 2, 8, 7]^T1287[i];
cst[prodim(1, ts, ss)] := ss;
end for;
m:=0;
for i in [1 .. 672] do if cst[i] ne [ ]
then m:=m+1; end if; end for; m;
Orbits(N1287s);

N1289:=Stabiliser(N,[1,2,8,9]);
S:=[1,2,8,9];
SS:=S^N;
SSS:=Setseq(SS);
for i in [1 .. # SS] do
for g in IN do if ts[1]*ts[2]*ts[8]*ts[9]
eq g*ts[Rep(SSS[i])[1]]*ts[Rep(SSS[i])[2]]

```



```

*ts[Rep(SSS[i])[3]]*ts[Rep(SSS[i])[4]]
then print SSS[i];
end if; end for; end for;
N1289s:=N1289;
# N1289s;
T1289:=Transversal(N,N1289s);
# T1289;
for i := 1 to # T1289 do
ss := [1, 2, 8, 9]T1289[i];
cst[prodim(1, ts, ss)] := ss;
end for;
m:=0;
for i in [1 .. 672] do if cst[i] ne [ ]
then m:=m+1; end if; end for; m;
Orbits(N1289s);

N12810:=Stabiliser(N,[1,2,8,10]);
S:=[1,2,8,10];
SS:=SN;
SSS:=Setseq(SS);
for i in [1 .. # SS] do
for g in IN do if ts[1]*ts[2]*ts[8]*ts[10] eq g*ts[Rep(SSS[i])[1]]*ts[Rep(SSS[i])[2]]
*ts[Rep(SSS[i])[3]]*ts[Rep(SSS[i])[4]]
then print SSS[i];
end if; end for; end for;
N12810s:=N12810;
# N12810s;
T12810:=Transversal(N,N12810s);
# T12810;
for i := 1 to # T12810 do
ss := [1, 2, 8, 10]T12810[i];

```

```

cst[prodim(1, ts, ss)] := ss;
end for;
m:=0;
for i in [1 .. 672] do if cst[i] ne [ ]
then m:=m+1; end if; end for; m;
Orbits(N12810s);

N12811:=Stabiliser(N,[1,2,8,11]);
S:=[1,2,8,11];
SS:=SN;
SSS:=Setseq(SS);
for i in [1 .. # SS] do
for g in IN do if ts[1]*ts[2]*ts[8]*ts[11]
eq g*ts[Rep(SSS[i])[1]]*ts[Rep(SSS[i])[2]]
*ts[Rep(SSS[i])[3]]*ts[Rep(SSS[i])[4]]
then print SSS[i];
end if; end for; end for;
N12811s:=N12811;
# N12811s;
T12811:=Transversal(N,N12811s);
# T12811;
for i := 1 to # T12811 do
ss := [1, 2, 8, 11]T12811[i];
cst[prodim(1, ts, ss)] := ss;
end for;
m:=0;
for i in [1 .. 672] do if cst[i] ne [ ]
then m:=m+1; end if; end for; m;
Orbits(N12811s);

N12812s:=N12812;

```

```

# N12812s;
T12812:=Transversal(N,N12812s);
# T12812;
for i := 1 to # T12812 do
ss := [1, 2, 8, 12]T12812[i];
cst[prodim(1, ts, ss)] := ss;
end for;
m:=0;
for i in [1 .. 672] do if cst[i] ne [ ]
then m:=m+1; end if; end for; m;
Orbits(N12812s);

N12813:=Stabiliser(N,[1,2,8,13]);
S:=[1,2,8,13];
SS:=SN;
SSS:=Setseq(SS);
for i in [1 .. # SS] do
for g in IN do if ts[1]*ts[2]*ts[8]*ts[13]
eq g*ts[Rep(SSS[i])[1]]*ts[Rep(SSS[i])[2]]
*ts[Rep(SSS[i])[3]]*ts[Rep(SSS[i])[4]]
then print SSS[i];
end if; end for; end for;
N12813s:=N12813;
# N12813s;
T12813:=Transversal(N,N12813s);
# T12813;
for i := 1 to # T12813 do
ss := [1, 2, 8, 13]T12813[i];
cst[prodim(1, ts, ss)] := ss;
end for;
m:=0;

```

```

for i in [1 .. 672] do if cst[i] ne [ ]
then m:=m+1; end if; end for; m;
Orbits(N12813s);

N12814:=Stabiliser(N,[1,2,8,14]);
S:=[1,2,8,14];
SS:=SN;
SSS:=Setseq(SS);
for i in [1 .. # SS] do
for g in IN do if ts[1]*ts[2]*ts[8]*ts[14]
eq g*ts[Rep(SSS[i])[1]]*ts[Rep(SSS[i])[2]]
*ts[Rep(SSS[i])[3]]*ts[Rep(SSS[i])[4]]
then print SSS[i];
end if; end for; end for;
N12814s:=N12814;
# N12814s;
T12814:=Transversal(N,N12814s);
# T12814;
for i := 1 to # T12814 do
ss := [1, 2, 8, 14]T12814[i];
cst[prodim(1, ts, ss)] := ss;
end for;
m:=0;
for i in [1 .. 672] do if cst[i] ne [ ]
then m:=m+1; end if; end for; m;
Orbits(N12814s);

N12815:=Stabiliser(N,[1,2,8,15]);
S:=[1,2,8,15];
SS:=SN;
SSS:=Setseq(SS);

```

```

for i in [1 .. # SS] do
for g in IN do if ts[1]*ts[2]*ts[8]*ts[15]
eq g*ts[Rep(SSS[i])[1]]*ts[Rep(SSS[i])[2]]
*ts[Rep(SSS[i])[3]]*ts[Rep(SSS[i])[4]]
then print SSS[i];
end if; end for; end for;
N12815s:=N12815;
# N12815s;
T12815:=Transversal(N,N12815s);
# T12815;
for i := 1 to # T12815 do
ss := [1, 2, 8, 15]T12815[i];
cst[prodim(1, ts, ss)] := ss;
end for;
m:=0;
for i in [1 .. 672] do if cst[i] ne [ ]
then m:=m+1; end if; end for; m;
Orbits(N12815s);

N1291:=Stabiliser(N,[1,2,9,1]);
S:=[1,2,9,1];
SS:=SN;
SSS:=Setseq(SS);
for i in [1 .. # SS] do
for g in IN do if ts[1]*ts[2]*ts[9]*ts[1]
eq g*ts[Rep(SSS[i])[1]]*ts[Rep(SSS[i])[2]]
*ts[Rep(SSS[i])[3]]*ts[Rep(SSS[i])[4]]
then print SSS[i];
end if; end for; end for;
N1291s:=N1291;
# N1291s;

```

```

T1291:=Transversal(N,N1291s);
# T1291;
for i := 1 to # T1291 do
ss := [1, 2, 9, 1]T1291[i];
cst[prodim(1, ts, ss)] := ss;
end for;
m:=0;
for i in [1 .. 672] do if cst[i] ne [ ]
then m:=m+1; end if; end for; m;
Orbits(N1291s);

N1292:=Stabiliser(N,[1,2,9,2]);
S:=[1,2,9,2];
SS:=SN;
SSS:=Setseq(SS);
for i in [1 .. # SS] do
for g in IN do if ts[1]*ts[2]*ts[9]*ts[2]
eq g*ts[Rep(SSS[i])[1]]*ts[Rep(SSS[i])[2]]
*ts[Rep(SSS[i])[3]]*ts[Rep(SSS[i])[4]]
then print SSS[i];
end if; end for; end for;
N1292s:=N1292;
# N1292s;
T1292:=Transversal(N,N1292s);
# T1292;
for i := 1 to # T1292 do
ss := [1, 2, 9, 2]T1292[i];
cst[prodim(1, ts, ss)] := ss;
end for;
m:=0;
for i in [1 .. 672] do if cst[i] ne [ ]

```

```

then m:=m+1; end if; end for; m;
Orbits(N1292s);

N1293:=Stabiliser(N,[1,2,9,3]);
S:=[1,2,9,3];
SS:=SN;
SSS:=Setseq(SS);
for i in [1 .. # SS] do
for g in IN do if ts[1]*ts[2]*ts[9]*ts[3]
eq g*ts[Rep(SSS[i])[1]]*ts[Rep(SSS[i])[2]] *ts[Rep(SSS[i])[3]]*ts[Rep(SSS[i])[4]]
then print SSS[i];
end if; end for; end for;
N1293s:=N1293;
# N1293s;
T1293:=Transversal(N,N1293s);
# T1293;
for i := 1 to # T1293 do
ss := [1, 2, 9, 3]T1293[i];
cst[prodim(1, ts, ss)] := ss;
end for;
m:=0;
for i in [1 .. 672] do if cst[i] ne [ ]
then m:=m+1; end if; end for; m;
Orbits(N1293s);

N1294:=Stabiliser(N,[1,2,9,4]);
S:=[1,2,9,4];
SS:=SN;
SSS:=Setseq(SS);
for i in [1 .. # SS] do
for g in IN do if ts[1]*ts[2]*ts[9]*ts[4]

```

```

eq g*ts[Rep(SSS[i])[1]]*ts[Rep(SSS[i])[2]]
*ts[Rep(SSS[i])[3]]*ts[Rep(SSS[i])[4]]
then print SSS[i];
end if; end for; end for;
N1294s:=N1294;
# N1294s;
T1294:=Transversal(N,N1294s);
# T1294;
for i := 1 to # T1294 do
ss := [1, 2, 9, 4]T1294[i];
cst[prodim(1, ts, ss)] := ss;
end for;
m:=0;
for i in [1 .. 672] do if cst[i] ne [ ]
then m:=m+1; end if; end for; m;
Orbits(N1294s);

N1295:=Stabiliser(N,[1,2,9,5]);
S:=[1,2,9,5];
SS:=SN;
SSS:=Setseq(SS);
for i in [1 .. # SS] do
for g in IN do if ts[1]*ts[2]*ts[9]*ts[5]
eq g*ts[Rep(SSS[i])[1]]*ts[Rep(SSS[i])[2]]
*ts[Rep(SSS[i])[3]]*ts[Rep(SSS[i])[4]]
then print SSS[i];
end if; end for; end for;
N1295s:=N1295;
# N1295s;
T1295:=Transversal(N,N1295s);
# T1295;

```



```

for i := 1 to # T1295 do
ss := [1, 2, 9, 5]T1295[i];
cst[prodim(1, ts, ss)] := ss;
end for;
m:=0;
for i in [1 .. 672] do if cst[i] ne [ ]
then m:=m+1; end if; end for; m;
Orbits(N1295s);

N1296:=Stabiliser(N,[1,2,9,6]);
S:=[1,2,9,6];
SS:=SN;
SSS:=Setseq(SS);
for i in [1 .. # SS] do
for g in IN do if ts[1]*ts[2]*ts[9]*ts[6]
eq g*ts[Rep(SSS[i])[1]]*ts[Rep(SSS[i])[2]]
*ts[Rep(SSS[i])[3]]*ts[Rep(SSS[i])[4]]
then print SSS[i];
end if; end for; end for;
N1296s:=N1296;
# N1296s;
T1296:=Transversal(N,N1296s);
# T1296;
for i := 1 to #T1296 do
ss := [1, 2, 9, 6]T1296[i];
cst[prodim(1, ts, ss)] := ss;
end for;
m:=0;
for i in [1 .. 672] do if cst[i] ne [ ]
then m:=m+1; end if; end for; m;
Orbits(N1296s);

```

```

N1297:=Stabiliser(N,[1,2,9,7]);
S:=[1,2,9,7];
SS:=S^N;
SSS:=Setseq(SS);
for i in [1 .. # SS] do
for g in IN do if ts[1]*ts[2]*ts[9]*ts[7]
eq g*ts[Rep(SSS[i])[1]]*ts[Rep(SSS[i])[2]]
*ts[Rep(SSS[i])[3]]*ts[Rep(SSS[i])[4]]
then print SSS[i];
end if; end for; end for;
N1297s:=N1297;
# N1297s;
T1297:=Transversal(N,N1297s);
# T1297;
for i := 1 to # T1297 do
ss := [1, 2, 9, 7]^T1297[i];
cst[prodim(1, ts, ss)] := ss;
end for;
m:=0;
for i in [1 .. 672] do if cst[i] ne [ ]
then m:=m+1; end if; end for; m;
Orbits(N1297s);

N1298:=Stabiliser(N,[1,2,9,8]);
S:=[1,2,9,8];
SS:=S^N;
SSS:=Setseq(SS);
for i in [1 .. # SS] do
for g in IN do if ts[1]*ts[2]*ts[9]*ts[8]
eq g*ts[Rep(SSS[i])[1]]*ts[Rep(SSS[i])[2]] *ts[Rep(SSS[i])[3]]*ts[Rep(SSS[i])[4]]

```

```

then print SSS[i];
end if; end for; end for;
N1298s:=N1298;
# N1298s;
T1298:=Transversal(N,N1298s);
# T1298;
for i := 1 to # T1298 do
ss := [1, 2, 9, 8]T1298[i];
cst[prodim(1, ts, ss)] := ss;
end for;
m:=0;
for i in [1 .. 672] do if cst[i] ne [ ]
then m:=m+1; end if; end for; m;
Orbits(N1298s);

N12910:=Stabiliser(N,[1,2,9,10]);
S:=[1,2,9,10];
SS:=SN;
SSS:=Setseq(SS);
for i in [1 .. # SS] do
for g in IN do if ts[1]*ts[2]*ts[9]*ts[10]
eq g*ts[Rep(SSS[i])[1]]*ts[Rep(SSS[i])[2]]
*ts[Rep(SSS[i])[3]]*ts[Rep(SSS[i])[4]]
then print SSS[i];
end if; end for; end for;
N12910s:=N12910;
# N12910s;
T12910:=Transversal(N,N12910s);
# T12910;
for i := 1 to # T12910 do
ss := [1, 2, 9, 10]T12910[i];

```

```

cst[prodim(1, ts, ss)] := ss;
end for;
m:=0;
for i in [1 .. 672] do if cst[i] ne [ ]
then m:=m+1; end if; end for; m;
Orbits(N12910s);

N12911:=Stabiliser(N,[1,2,9,11]);
S:=[1,2,9,11];
SS:=SN;
SSS:=Setseq(SS);
for i in [1 .. # SS] do
for g in IN do if ts[1]*ts[2]*ts[9]*ts[11]
eq g*ts[Rep(SSS[i])[1]]*ts[Rep(SSS[i])[2]]
*ts[Rep(SSS[i])[3]]*ts[Rep(SSS[i])[4]]
then print SSS[i];
end if; end for; end for;
N12911s:=N12911;
# N12911s;
T12911:=Transversal(N,N12911s);
# T12911;
for i := 1 to # T12911 do
ss := [1, 2, 9, 11]T12911[i];
cst[prodim(1, ts, ss)] := ss;
end for;
m:=0;
for i in [1 .. 672] do if cst[i] ne [ ]
then m:=m+1; end if; end for; m;
Orbits(N12911s);

N12912:=Stabiliser(N,[1,2,9,12]);

```

```

S:=[1,2,9,12];
SS:=SN;
SSS:=Setseq(SS);
for i in [1 .. # SS] do
for g in IN do if ts[1]*ts[2]*ts[9]*ts[12]
eq g*ts[Rep(SSS[i])[1]]*ts[Rep(SSS[i])[2]]
*ts[Rep(SSS[i])[3]]*ts[Rep(SSS[i])[4]]
then print SSS[i];
end if; end for; end for;
N12912s:=N12912;
# N12912s;
T12912:=Transversal(N,N12912s);
# T12912;
for i := 1 to # T12912 do
ss := [1, 2, 9, 12]T12912[i];
cst[prodim(1, ts, ss)] := ss;
end for;
m:=0;
for i in [1 .. 672] do if cst[i] ne [ ]
then m:=m+1; end if; end for; m;
Orbits(N12912s);

N12913:=Stabiliser(N,[1,2,9,13]);
S:=[1,2,9,13];
SS:=SN;
SSS:=Setseq(SS);
for i in [1 .. # SS] do
for g in IN do if ts[1]*ts[2]*ts[9]*ts[13]
eq g*ts[Rep(SSS[i])[1]]*ts[Rep(SSS[i])[2]]
*ts[Rep(SSS[i])[3]]*ts[Rep(SSS[i])[4]]
then print SSS[i];

```

```

end if; end for; end for;
N12913s:=N12913;
# N12913s;
T12913:=Transversal(N,N12913s);
# T12913;
for i := 1 to # T12913 do
ss := [1, 2, 9, 13]T12913[i];
cst[prodim(1, ts, ss)] := ss;
end for;
m:=0;
for i in [1 .. 672] do if cst[i] ne [ ]
then m:=m+1; end if; end for; m;
Orbits(N12913s);

N12914:=Stabiliser(N,[1,2,9,14]);
S:=[1,2,9,14];
SS:=SN;
SSS:=Setseq(SS);
for i in [1 .. # SSS] do
for g in IN do if ts[1]*ts[2]*ts[9]*ts[14]
eq g*ts[Rep(SSS[i])[1]]*ts[Rep(SSS[i])[2]]
*ts[Rep(SSS[i])[3]]*ts[Rep(SSS[i])[4]]
then print SSS[i];
end if; end for; end for;
N12914s:=N12914;
# N12914s;
T12914:=Transversal(N,N12914s);
# T12914;
for i := 1 to # T12914 do
ss := [1, 2, 9, 14]T12914[i];
cst[prodim(1, ts, ss)] := ss;

```

```

end for;
m:=0;
for i in [1 .. 672] do if cst[i] ne [ ]
then m:=m+1; end if; end for; m;
Orbits(N12914s);

N12915:=Stabiliser(N,[1,2,9,15]);
S:=[1,2,9,15];
SS:=SN;
SSS:=Setseq(SS);
for i in [1 .. # SS] do
for g in IN do if ts[1]*ts[2]*ts[9]*ts[15]
eq g*ts[Rep(SSS[i])[1]]*ts[Rep(SSS[i])[2]]
*ts[Rep(SSS[i])[3]]*ts[Rep(SSS[i])[4]]
then print SSS[i];
end if; end for; end for;
N12915s:=N12915;
# N12915s;
T12915:=Transversal(N,N12915s);
# T12915;
for i := 1 to # T12915 do
ss := [1, 2, 9, 15]T12915[i];
cst[prodim(1, ts, ss)] := ss;
end for;
m:=0;
for i in [1 .. 672] do if cst[i] ne [ ]
then m:=m+1; end if; end for; m;
Orbits(N12915s);

N12141:=Stabiliser(N,[1,2,14,1]);
S:=[1,2,14,1];

```

```

SS:=SN;
SSS:=Setseq(SS);
for i in [1 .. # SS] do
for g in IN do if ts[1]*ts[2]*ts[14]*ts[1]
eq g*ts[Rep(SSS[i])[1]]*ts[Rep(SSS[i])[2]]
*ts[Rep(SSS[i])[3]]*ts[Rep(SSS[i])[4]]
then print SSS[i];
end if; end for; end for;
N12141s:=N12141;
# N12141s;
T12141:=Transversal(N,N12141s);
# T12141;
for i := 1 to # T12141 do
ss := [1, 2, 9, 1]T1291[i];
cst[prodim(1, ts, ss)] := ss;
end for;
m:=0;
for i in [1 .. 672] do if cst[i] ne [ ]
then m:=m+1; end if; end for; m;
Orbits(N12141s);

N12142:=Stabiliser(N,[1,2,14,2]);
S:=[1,2,14,2]; SS:=SN;
SSS:=Setseq(SS);
for i in [1 .. # SS] do
for g in IN do if ts[1]*ts[2]*ts[14]*ts[2]
eq g*ts[Rep(SSS[i])[1]]*ts[Rep(SSS[i])[2]]
*ts[Rep(SSS[i])[3]]*ts[Rep(SSS[i])[4]]
then print SSS[i];
end if; end for; end for;
N12142s:=N12142;

```



```

# N12142s;
T12142:=Transversal(N,N12142s);
# T12142;
for i := 1 to #T12142 do
ss := [1, 2, 14, 2]T12142[i];
cst[prodim(1, ts, ss)] := ss;
end for;
m:=0;
for i in [1 .. 672] do if cst[i] ne [ ]
then m:=m+1; end if; end for; m;
Orbits(N12142s);

N12143:=Stabiliser(N,[1,2,14,3]);
S:=[1,2,14,3];
SS:=SN;
SSS:=Setseq(SS);
for i in [1 .. # SS] do
for g in IN do if ts[1]*ts[2]*ts[14]*ts[3]
eq g*ts[Rep(SSS[i])[1]]*ts[Rep(SSS[i])[2]]
*ts[Rep(SSS[i])[3]]*ts[Rep(SSS[i])[4]]
then print SSS[i];
end if; end for; end for;
N12143s:=N12143;
# N12143s;
T12143:=Transversal(N,N12143s);
# T12143;
for i := 1 to # T12143 do
ss := [1, 2, 14, 3]T12143[i];
cst[prodim(1, ts, ss)] := ss;
end for;
m:=0;

```

```

for i in [1 .. 672] do if cst[i] ne [ ]
then m:=m+1; end if; end for; m;
Orbits(N12143s);

N12144:=Stabiliser(N,[1,2,14,4]);
S:=[1,2,14,4];
SS:=SN;
SSS:=Setseq(SS);
for i in [1 .. # SS] do
for g in IN do if ts[1]*ts[2]*ts[14]*ts[4]
eq g*ts[Rep(SSS[i])[1]]*ts[Rep(SSS[i])[2]]
*ts[Rep(SSS[i])[3]]*ts[Rep(SSS[i])[4]]
then print SSS[i];
end if; end for; end for;
N12144s:=N12144;
# N12144s;
T12144:=Transversal(N,N12144s);
# T12144;
for i := 1 to # T12144 do
ss := [1, 2, 14, 4]T12144[i];
cst[prodim(1, ts, ss)] := ss;
end for;
m:=0;
for i in [1 .. 672] do if cst[i] ne [ ]
then m:=m+1; end if; end for; m;
Orbits(N12144s);

N12145:=Stabiliser(N,[1,2,14,5]);
S:=[1,2,14,5];
SS:=SN;
SSS:=Setseq(SS);

```

```

for i in [1 .. #SS] do
for g in IN do if ts[1]*ts[2]*ts[14]*ts[5]
eq g*ts[Rep(SSS[i])[1]]*ts[Rep(SSS[i])[2]]
*ts[Rep(SSS[i])[3]]*ts[Rep(SSS[i])[4]]
then print SSS[i];
end if; end for; end for;
N12145s:=N12145;
#N12145s;
T12145:=Transversal(N,N12145s);
# T12145;
for i := 1 to # T12145 do
ss := [1, 2, 14, 5]T12145[i];
cst[prodim(1, ts, ss)] := ss;
end for;
m:=0;
for i in [1 .. 672] do if cst[i] ne [ ]
then m:=m+1; end if; end for; m;
Orbits(N12145);

N12146:=Stabiliser(N,[1,2,14,6]);
S:=[1,2,14,6];
SS:=SN;
SSS:=Setseq(SS);
for i in [1 .. # SS] do
for g in IN do if ts[1]*ts[2]*ts[14]*ts[6]
eq g*ts[Rep(SSS[i])[1]]*ts[Rep(SSS[i])[2]]*ts[Rep(SSS[i])[3]]
*ts[Rep(SSS[i])[4]]
then print SSS[i];
end if; end for; end for;
N12146s:=N12146;
# N12146s;

```

```

T12146:=Transversal(N,N12146s);
# T12146;
for i := 1 to # T12146 do
ss := [1, 2, 14, 6]T12146[i];
cst[prodim(1, ts, ss)] := ss;
end for;
m:=0;
for i in [1 .. 672] do if cst[i] ne [ ]
then m:=m+1; end if; end for; m;
Orbits(N12146s);

N12147:=Stabiliser(N,[1,2,14,7]);
S:=[1,2,14,7];
SS:=SN;
SSS:=Setseq(SS); for i in [1 .. # SS] do
for g in IN do if ts[1]*ts[2]*ts[14]*ts[7]
eq g*ts[Rep(SSS[i])[1]]*ts[Rep(SSS[i])[2]]*ts[Rep(SSS[i])[3]]
*ts[Rep(SSS[i])[4]]
then print SSS[i];
end if; end for; end for;
N12147s:=N12147;
# N12147s;
T12147:=Transversal(N,N12147s);
# T12147;
for i := 1 to #T12147 do
ss := [1, 2, 14, 7]T12147[i];
cst[prodim(1, ts, ss)] := ss;
end for;
m:=0;
for i in [1 .. 672] do if cst[i] ne [ ]
then m:=m+1; end if; end for; m;

```

```

Orbits(N12147s);

N12148:=Stabiliser(N,[1,2,14,8]);
S:=[1,2,14,8];
SS:=SN;
SSS:=Setseq(SS);
for i in [1 .. # SS] do
for g in IN do if ts[1]*ts[2]*ts[14]*ts[8]
eq g*ts[Rep(SSS[i])[1]]*ts[Rep(SSS[i])[2]]*ts[Rep(SSS[i])[3]]
*ts[Rep(SSS[i])[4]]
then print SSS[i];
end if; end for; end for;
N12148s:=N12148;
# N12148s;
T12148:=Transversal(N,N12148s);
# T12148;
for i := 1 to # T12148 do
ss := [1, 2, 14, 8]T12148[i];
cst[prodim(1, ts, ss)] := ss;
end for;
m:=0;
for i in [1 .. 672] do if cst[i] ne [ ]
then m:=m+1; end if; end for; m;
Orbits(N12148s);

N12149:=Stabiliser(N,[1,2,14,9]);
S:=[1,2,14,9];
SS:=SN;
SSS:=Setseq(SS);
for i in [1 .. # SS] do
for g in IN do if ts[1]*ts[2]*ts[14]*ts[9]

```

```

eq g*ts[Rep(SSS[i])[1]]*ts[Rep(SSS[i])[2]]*ts[Rep(SSS[i])[3]]
*ts[Rep(SSS[i])[4]]
then print SSS[i];
end if; end for; end for;
N12149s:=N12149;
# N12149s;
T12149:=Transversal(N,N12149s);
# T12149;
for i := 1 to # T12149 do
ss := [1, 2, 14, 9]T12149[i];
cst[prodim(1, ts, ss)] := ss;
end for;
m:=0;
for i in [1 .. 672] do if cst[i] ne [ ]
then m:=m+1; end if; end for; m;
Orbits(N12149s);

N121410:=Stabiliser(N,[1,2,14,10]);
S:=[1,2,14,10];
SS:=SN;
SSS:=Setseq(SS);
for i in [1 .. # SS] do
for g in IN do if ts[1]*ts[2]*ts[14]*ts[10]
eq g*ts[Rep(SSS[i])[1]]*ts[Rep(SSS[i])[2]]*ts[Rep(SSS[i])[3]]
*ts[Rep(SSS[i])[4]]
then print SSS[i];
end if; end for; end for;
N121410s:=N121410;
# N121410s;
T121410:=Transversal(N,N121410s);
# T121410;

```

```

for i := 1 to # T121410 do
ss := [1, 2, 14, 10]T121410[i];
cst[prodim(1, ts, ss)] := ss;
end for;
m:=0;
for i in [1 .. 672] do if cst[i] ne [ ]
then m:=m+1; end if; end for; m;
Orbits(N121410s);

N121411:=Stabiliser(N,[1,2,14,11]);
S:=[1,2,14,11];
SS:=SN;
SSS:=Setseq(SS); for i in [1 .. # SS] do
for g in IN do if ts[1]*ts[2]*ts[14]*ts[11]
eq g*ts[Rep(SSS[i])[1]]*ts[Rep(SSS[i])[2]]*ts[Rep(SSS[i])[3]]
*ts[Rep(SSS[i])[4]]
then print SSS[i];
end if; end for; end for;
N121411s:=N121411;
#N121411s;
T121411:=Transversal(N,N121411s);
# T121411;
for i := 1 to # T121411 do
ss := [1, 2, 14, 11]T121411[i];
cst[prodim(1, ts, ss)] := ss;
end for;
m:=0;
for i in [1 .. 672] do if cst[i] ne [ ]
then m:=m+1; end if; end for; m;
Orbits(N121411s);

```

```

N121412:=Stabiliser(N,[1,2,14,12]);
S:=[1,2,14,12];
SS:=S^N;
SSS:=Setseq(SS);
for i in [1 .. # SS] do
for g in IN do if ts[1]*ts[2]*ts[14]*ts[12]
eq g*ts[Rep(SSS[i])[1]]*ts[Rep(SSS[i])[2]]*ts[Rep(SSS[i])[3]]
*ts[Rep(SSS[i])[4]]
then print SSS[i];
end if; end for; end for;
N121412s:=N121412;
# N121412s;
T121412:=Transversal(N,N121412s);
# T121412;
for i := 1 to # T121412 do
ss := [1, 2, 14, 12]^T121412[i];
cst[prodim(1, ts, ss)] := ss;
end for;
m:=0;
for i in [1 .. 672] do if cst[i] ne [ ]
then m:=m+1; end if; end for; m;
Orbits(N121412s);

N121413:=Stabiliser(N,[1,2,14,13]);
S:=[1,2,14,13];
SS:=S^N;
SSS:=Setseq(SS);
for i in [1 .. # SS] do
for g in IN do if ts[1]*ts[2]*ts[14]*ts[13]
eq g*ts[Rep(SSS[i])[1]]*ts[Rep(SSS[i])[2]]*ts[Rep(SSS[i])[3]]
*ts[Rep(SSS[i])[4]]

```



```

then print SSS[i];
end if; end for; end for;
N121413s:=N121413;
# N121413s;
T121413:=Transversal(N,N121413s);
# T121413;
for i := 1 to # T121413 do
ss := [1, 2, 14, 13]T121413[i];
cst[prodim(1, ts, ss)] := ss;
end for;
m:=0;
for i in [1 .. 672] do if cst[i] ne [ ]
then m:=m+1; end if; end for; m;
Orbits(N121413s);

N121415:=Stabiliser(N,[1,2,14,15]);
S:=[1,2,14,15];
SS:=SN;
SSS:=Setseq(SS);
for i in [1 .. # SS] do
for g in IN do if ts[1]*ts[2]*ts[14]*ts[15]
eq g*ts[Rep(SSS[i])[1]]*ts[Rep(SSS[i])[2]]*ts[Rep(SSS[i])[3]]
*ts[Rep(SSS[i])[4]]
then print SSS[i];
end if; end for; end for;
N121415s:=N121415;
# N121415s;
T121415:=Transversal(N,N121415s);
# T121415;
for i := 1 to # T121415 do
ss := [1, 2, 14, 15]T121415[i];

```

```

cst[prodim(1, ts, ss)] := ss;
end for;
m:=0;
for i in [1 .. 672] do if cst[i] ne [ ]
then m:=m+1; end if; end for; m;
Orbits(N121415s);

N1312:=Stabiliser(N,[1,3,1,2]);
S:=[1,3,1,2];
SS:=SN;
SSS:=Setseq(SS); for i in [1 .. # SS] do
for g in IN do if ts[1]*ts[3]*ts[1]*ts[2]
eq g*ts[Rep(SSS[i])[1]]*ts[Rep(SSS[i])[2]]*ts[Rep(SSS[i])[3]]
*ts[Rep(SSS[i])[4]]
then print SSS[i];
end if; end for; end for;
N1312s:=N1312;
# N1312s;
T1312:=Transversal(N,N1312s);
# T1312;
for i := 1 to # T1312 do
ss := [1, 3, 1, 2]T1312[i];
cst[prodim(1, ts, ss)] := ss;
end for;
m:=0;
for i in [1 .. 672] do if cst[i] ne [ ]
then m:=m+1; end if; end for; m;
Orbits(N1312s);

N1314:=Stabiliser(N,[1,3,1,4]);
S:=[1,3,1,4];

```

```

SS:=SN;
SSS:=Setseq(SS);
for i in [1 .. # SS] do
for g in IN do if ts[1]*ts[3]*ts[1]*ts[4]
eq g*ts[Rep(SSS[i])[1]]*ts[Rep(SSS[i])[2]]*ts[Rep(SSS[i])[3]]
*ts[Rep(SSS[i])[4]]
then print SSS[i];
end if; end for; end for;
N1314s:=N1314;
# N1314s;
T1314:=Transversal(N,N1314s);
# T1314;
for i := 1 to # T1314 do
ss := [1, 3, 1, 4]T1314[i];
cst[prodim(1, ts, ss)] := ss;
end for;
m:=0;
for i in [1 .. 672] do if cst[i] ne [ ]
then m:=m+1; end if; end for; m;
Orbits(N1314s);

N1316:=Stabiliser(N,[1,3,1,6]);
S:=[1,3,1,6];
SS:=SN;
SSS:=Setseq(SS);
for i in [1 .. # SS] do
for g in IN do if ts[1]*ts[3]*ts[1]*ts[6]
eq g*ts[Rep(SSS[i])[1]]*ts[Rep(SSS[i])[2]]*ts[Rep(SSS[i])[3]]
*ts[Rep(SSS[i])[4]]
then print SSS[i];
end if; end for; end for;

```

```

N1316s:=N1316;
# N1316s;
T1316:=Transversal(N,N1316s);
# T1316;
for i := 1 to # T1316 do
ss := [1, 3, 1, 6]T1316[i];
cst[prodim(1, ts, ss)] := ss;
end for;
m:=0;
for i in [1 .. 672] do if cst[i] ne []
then m:=m+1; end if; end for; m;
Orbits(N1316s);

N1317:=Stabiliser(N,[1,3,1,7]);
S:=[1,3,1,7];
SS:=SN;
SSS:=Setseq(SS);
for i in [1 .. # SS] do
for g in IN do if ts[1]*ts[3]*ts[1]*ts[7]
eq g*ts[Rep(SSS[i])[1]]*ts[Rep(SSS[i])[2]]*ts[Rep(SSS[i])[3]]
*ts[Rep(SSS[i])[4]]
then print SSS[i];
end if; end for; end for;
N1317s:=N1317;
#N1317s;
T1317:=Transversal(N,N1317s);
# T1317;
for i := 1 to # T1317 do
ss := [1, 3, 1, 7]T1317[i];
cst[prodim(1, ts, ss)] := ss;
end for;

```

```

m:=0;
for i in [1 .. 672] do if cst[i] ne [ ]
then m:=m+1; end if; end for; m;
Orbits(N1317s);

N1318:=Stabiliser(N,[1,3,1,8]);
S:=[1,3,1,8];
SS:=SN;
SSS:=Setseq(SS);
for i in [1 .. # SSS] do
for g in IN do if ts[1]*ts[3]*ts[1]*ts[8]
eq g*ts[Rep(SSS[i])[1]]*ts[Rep(SSS[i])[2]]*ts[Rep(SSS[i])[3]]
*ts[Rep(SSS[i])[4]]
then print SSS[i];
end if; end for; end for;
N1318s:=N1318;
# N1318s;
T1318:=Transversal(N,N1318s);
# T1318;
for i := 1 to # T1318 do
ss := [1, 3, 1, 8]T1318[i];
cst[prodim(1, ts, ss)] := ss;
end for;
m:=0;
for i in [1 .. 672] do if cst[i] ne [ ]
then m:=m+1; end if; end for; m;
Orbits(N1318s);

N13111:=Stabiliser(N,[1,3,1,11]);
S:=[1,3,1,11];
SS:=SN;

```

```

SSS:=Setseq(SS); for i in [1 .. # SS] do
for g in IN do if ts[1]*ts[3]*ts[1]*ts[11]
eq g*ts[Rep(SSS[i])[1]]*ts[Rep(SSS[i])[2]]*ts[Rep(SSS[i])[3]]
*ts[Rep(SSS[i])[4]]
then print SSS[i];
end if; end for; end for;
N13111s:=N13111;
# N13111s;
T13111:=Transversal(N,N13111s);
# T13111;
for i := 1 to # T13111 do
ss := [1, 3, 1, 11]T13111[i];
cst[prodim(1, ts, ss)] := ss;
end for;
m:=0;
for i in [1 .. 672] do if cst[i] ne [ ]
then m:=m+1; end if; end for; m;
Orbits(N13111s);

N1351:=Stabiliser(N,[1,3,5,1]);
S:=[1,3,5,1];
SS:=SN;
SSS:=Setseq(SS); for i in [1 .. # SS] do
for g in IN do if ts[1]*ts[3]*ts[5]*ts[1]
eq g*ts[Rep(SSS[i])[1]]*ts[Rep(SSS[i])[2]]*ts[Rep(SSS[i])[3]]
*ts[Rep(SSS[i])[4]]
then print SSS[i];
end if; end for; end for;
N1351s:=N1351;
# N1351s;
T1351:=Transversal(N,N1351s);

```

```

# T1351;
for i := 1 to # T1351 do
ss := [1, 3, 5, 1]T1351[i];
cst[prodim(1, ts, ss)] := ss;
end for;
m:=0;
for i in [1 .. 672] do if cst[i] ne [ ]
then m:=m+1; end if; end for; m;
Orbits(N1351s);

N1352:=Stabiliser(N,[1,3,5,2]);
S:=[1,3,5,2];
SS:=SN;
SSS:=Setseq(SS);
for i in [1 .. # SS] do
for g in IN do if ts[1]*ts[3]*ts[5]*ts[2]
eq g*ts[Rep(SSS[i])[1]]*ts[Rep(SSS[i])[2]]*ts[Rep(SSS[i])[3]]
*ts[Rep(SSS[i])[4]]
then print SSS[i];
end if; end for; end for;
N1352s:=N1352;
# N1352s;
T1352:=Transversal(N,N1352s);
# T1352;
for i := 1 to # T1352 do
ss := [1, 3, 5, 2]T1352[i];
cst[prodim(1, ts, ss)] := ss;
end for;
m:=0;
for i in [1 .. 672] do if cst[i] ne [ ]
then m:=m+1; end if; end for; m;

```

```

Orbits(N1352s);

N1353:=Stabiliser(N,[1,3,5,3]);
S:=[1,3,5,3];
SS:=SN;
SSS:=Setseq(SS);
for i in [1 .. # SS] do
for g in IN do if ts[1]*ts[3]*ts[5]*ts[3]
eq g*ts[Rep(SSS[i])[1]]*ts[Rep(SSS[i])[2]]*ts[Rep(SSS[i])[3]]
*ts[Rep(SSS[i])[4]]
then print SSS[i];
end if; end for; end for;
N1353s:=N1353;
# N1353s;
T1353:=Transversal(N,N1353s);
# T1353;
for i := 1 to # T1353 do
ss := [1, 3, 5, 3]T1353[i];
cst[prodim(1, ts, ss)] := ss;
end for;
m:=0;
for i in [1 .. 672] do if cst[i] ne [ ]
then m:=m+1; end if; end for; m;
Orbits(N1353s);

N1354:=Stabiliser(N,[1,3,5,4]);
S:=[1,3,5,4];
SS:=SN;
SSS:=Setseq(SS);
for i in [1 .. # SS] do
for g in IN do if ts[1]*ts[3]*ts[5]*ts[4]

```



```

eq g*ts[Rep(SSS[i])[1]]*ts[Rep(SSS[i])[2]]*ts[Rep(SSS[i])[3]]
*ts[Rep(SSS[i])[4]]
then print SSS[i];
end if; end for; end for;
N1354s:=N1354;
# N1354s;
T1354:=Transversal(N,N1354s);
# T1354;
for i := 1 to # T1354 do
ss := [1, 3, 5, 4]T1354[i];
cst[prodim(1, ts, ss)] := ss;
end for;
m:=0;
for i in [ 1 .. 672] do if cst[i] ne [ ]
then m:=m+1; end if; end for; m;
Orbits(N1354s);

N1356:=Stabiliser(N,[1,3,5,6]);
S:=[1,3,5,6];
SS:=SN;
SSS:=Setseq(SS);
for i in [1 .. # SS] do
for g in IN do if ts[1]*ts[3]*ts[5]*ts[6]
eq g*ts[Rep(SSS[i])[1]]*ts[Rep(SSS[i])[2]]*ts[Rep(SSS[i])[3]]
*ts[Rep(SSS[i])[4]]
then print SSS[i];
end if; end for; end for;
N1356s:=N1356;
# N1356s;
T1356:=Transversal(N,N1356s);
# T1356;

```

```

for i := 1 to # T1356 do
ss := [1, 3, 5, 6]T1356[i];
cst[prodim(1, ts, ss)] := ss;
end for;
m:=0;
for i in [1 .. 672] do if cst[i] ne [ ]
then m:=m+1; end if; end for; m;
Orbits(N1356s);

N1357:=Stabiliser(N,[1,3,5,7]);
S:=[1,3,5,7];
SS:SN;
SSS:=Setseq(SS);
for i in [1 .. # SS] do
for g in IN do if ts[1]*ts[3]*ts[5]*ts[7]
eq g*ts[Rep(SSS[i])[1]]*ts[Rep(SSS[i])[2]]*ts[Rep(SSS[i])[3]]
*ts[Rep(SSS[i])[4]]
then print SSS[i];
end if; end for; end for;
N1357s:=N1357;
# N1357s;
T1357:=Transversal(N,N1357s);
# T1357;
for i := 1 to # T1357 do
ss := [1, 3, 5, 7]T1357[i];
cst[prodim(1, ts, ss)] := ss;
end for;
m:=0;
for i in [1 .. 672] do if cst[i] ne [ ]
then m:=m+1; end if; end for; m;
Orbits(N1357s);

```

```

N1358:=Stabiliser(N,[1,3,5,8]);
S:=[1,3,5,8];
SS:=S^N;
SSS:=Setseq(SS);
for i in [1 .. # SS] do
for g in IN do if ts[1]*ts[3]*ts[5]*ts[8]
eq g*ts[Rep(SSS[i])[1]]*ts[Rep(SSS[i])[2]]*ts[Rep(SSS[i])[3]]
*ts[Rep(SSS[i])[4]]
then print SSS[i];
end if; end for; end for;
N1358s:=N1358;
# N1358s;
T1358:=Transversal(N,N1358s);
# T1358;
for i := 1 to # T1358 do
ss := [1, 3, 5, 8]^T1358[i];
cst[prodim(1, ts, ss)] := ss;
end for;
m:=0;
for i in [1 .. 672] do if cst[i] ne [ ]
then m:=m+1; end if; end for; m;
Orbits(N1358s);

N1359:=Stabiliser(N,[1,3,5,9]);
S:=[1,3,5,9];
SS:=S^N;
SSS:=Setseq(SS);
for i in [1 .. # SS] do
for g in IN do if ts[1]*ts[3]*ts[5]*ts[9]
eq g*ts[Rep(SSS[i])[1]]*ts[Rep(SSS[i])[2]]*ts[Rep(SSS[i])[3]]

```

```

*ts[Rep(SSS[i])[4]]
then print SSS[i];
end if; end for; end for;
N1359s:=N1359;
# N1359s;
T1359:=Transversal(N,N1359s);
# T1359;
for i := 1 to # T1359 do
ss := [1, 3, 5, 9]T1359[i];
cst[prodim(1, ts, ss)] := ss;
end for;
m:=0;
for i in [1 .. 672] do if cst[i] ne [ ]
then m:=m+1; end if; end for; m;
Orbits(N1359s);

N13510:=Stabiliser(N,[1,3,5,10]);
S:=[1,3,5,10];
SS:=SN;
SSS:=Setseq(SS); for i in [1 .. #SS] do
for g in IN do if ts[1]*ts[3]*ts[5]*ts[10]
eq g*ts[Rep(SSS[i])[1]]*ts[Rep(SSS[i])[2]]*ts[Rep(SSS[i])[3]]
*ts[Rep(SSS[i])[4]]
then print SSS[i];
end if; end for; end for;
N13510s:=N13510;
# N13510s;
T13510:=Transversal(N,N13510s);
# T13510;
for i := 1 to # T13510 do
ss := [1, 3, 5, 10]T13510[i];

```

```

cst[prodim(1, ts, ss)] := ss;
end for;
m:=0;
for i in [1 .. 672] do if cst[i] ne [ ]
then m:=m+1; end if; end for; m;
Orbits(N13510s);

N13511:=Stabiliser(N,[1,3,5,11]);
S:=[1,3,5,11];
SS:=SN;
SSS:=Setseq(SS);
for i in [1 .. # SS] do
for g in IN do if ts[1]*ts[3]*ts[5]*ts[11]
eq g*ts[Rep(SSS[i])[1]]*ts[Rep(SSS[i])[2]]*ts[Rep(SSS[i])[3]]
*ts[Rep(SSS[i])[4]]
then print SSS[i];
end if; end for; end for;
N13511s:=N13511;
# N13511s;
T13511:=Transversal(N,N13511s);
# T13511;
for i := 1 to # T13511 do
ss := [1, 3, 5, 11]T13511[i];
cst[prodim(1, ts, ss)] := ss;
end for;
m:=0;
for i in [1 .. 672] do if cst[i] ne [ ]
then m:=m+1; end if; end for; m;
Orbits(N13511s);

N13512:=Stabiliser(N,[1,3,5,12]);

```

```

S:=[1,3,5,12];
SS:=SN;
SSS:=Setseq(SS);
for i in [1 .. # SS] do
for g in IN do if ts[1]*ts[3]*ts[5]*ts[12]
eq g*ts[Rep(SSS[i])[1]]*ts[Rep(SSS[i])[2]]*ts[Rep(SSS[i])[3]]
*ts[Rep(SSS[i])[4]]
then print SSS[i];
end if; end for; end for;
N13512s:=N13512;
# N13512s;
T13512:=Transversal(N,N13512s);
# T13512;
for i := 1 to # T13512 do
ss := [1, 3, 5, 12]T13512[i];
cst[prodim(1, ts, ss)] := ss;
end for;
m:=0;
for i in [1 .. 672] do if cst[i] ne [ ]
then m:=m+1; end if; end for; m;
Orbits(N13512s);

N13513:=Stabiliser(N,[1,3,5,13]);
S:=[1,3,5,13];
SS:=SN;
SSS:=Setseq(SS);
for i in [1 .. # SS] do
for g in IN do if ts[1]*ts[3]*ts[5]*ts[13]
eq g*ts[Rep(SSS[i])[1]]*ts[Rep(SSS[i])[2]]*ts[Rep(SSS[i])[3]]
*ts[Rep(SSS[i])[4]]
then print SSS[i];

```

```

end if; end for; end for;
N13513s:=N13513;
# N13513s;
T13513:=Transversal(N,N13513s);
#T13513;
for i := 1 to # T13513 do
ss := [1, 3, 5, 13]T13513[i];
cst[prodim(1, ts, ss)] := ss;
end for;
m:=0;
for i in [1 .. 672] do if cst[i] ne [ ]
then m:=m+1; end if; end for; m;
Orbits(N13513s);

N13514:=Stabiliser(N,[1,3,5,14]);
S:=[1,3,5,14];
SS:=SN;
SSS:=Setseq(SS);
for i in [1 .. # SS] do
for g in IN do if ts[1]*ts[3]*ts[5]*ts[14]
eq g*ts[Rep(SSS[i])[1]]*ts[Rep(SSS[i])[2]]*ts[Rep(SSS[i])[3]]
*ts[Rep(SSS[i])[4]]
then print SSS[i];
end if; end for; end for;
N13514s:=N13514;
# N13514s;
T13514:=Transversal(N,N13514s);
# T13514;
for i := 1 to # T13514 do
ss := [1, 3, 5, 14]T13514[i];
cst[prodim(1, ts, ss)] := ss;

```

```

end for;
m:=0;
for i in [1 .. 672] do if cst[i] ne [ ]
then m:=m+1; end if; end for; m;
Orbits(N13514s);

N13515:=Stabiliser(N,[1,3,5,15]);
S:=[1,3,5,15];
SS:=SN;
SSS:=Setseq(SS); for i in [1 .. # SS] do
for g in IN do if ts[1]*ts[3]*ts[5]*ts[15]
eq g*ts[Rep(SSS[i])[1]]*ts[Rep(SSS[i])[2]]*ts[Rep(SSS[i])[3]]
*ts[Rep(SSS[i])[4]]
then print SSS[i];
end if; end for; end for;
N13515s:=N13515;
# N13515s;
T13515:=Transversal(N,N13515s);
# T13515;
for i := 1 to # T13515 do
ss := [1, 3, 5, 15]T13515[i];
cst[prodim(1, ts, ss)] := ss;
end for;
m:=0;
for i in [1 .. 672] do if cst[i] ne [ ]
then m:=m+1; end if; end for; m;
Orbits(N13515s);

N13101:=Stabiliser(N,[1,3,10,1]);
S:=[1,3,10,1];
SS:=SN;

```



```

SSS:=Setseq(SS);
for i in [1 .. # SS] do
for g in IN do if ts[1]*ts[3]*ts[10]*ts[1]
eq g*ts[Rep(SSS[i])[1]]*ts[Rep(SSS[i])[2]]*ts[Rep(SSS[i])[3]]
*ts[Rep(SSS[i])[4]]
then print SSS[i];
end if; end for; end for;
N13101s:=N13101;
# N13101s;
T13101:=Transversal(N,N13101s);
# T13101;
for i := 1 to # T13101 do
ss := [1, 3, 10, 1]T13101[i];
cst[prodim(1, ts, ss)] := ss;
end for;
m:=0;
for i in [1 .. 672] do if cst[i] ne [ ]
then m:=m+1; end if; end for; m;
Orbits(N13101s);

N12161:=Stabiliser(N,[1,2,1,6,1]);
S:=[1,2,1,6,1];
SS:=SN;
SSS:=Setseq(SS);
for i in [1 .. # SS] do
for g in IN do if ts[1]*ts[2]*ts[1]*ts[6]*ts[1]
eq g*ts[Rep(SSS[i])[1]]*ts[Rep(SSS[i])[2]]*ts[Rep(SSS[i])[3]]
*ts[Rep(SSS[i])[4]]*ts[Rep(SSS[i])[5]]
then print SSS[i];
end if; end for; end for;
N12161s:=N12161;

```

```

# N12161s;
T12161:=Transversal(N,N12161s);
# T12161;
for i := 1 to # T12161 do
ss := [1, 2, 1, 6, 1]T12161[i];
cst[prodim(1, ts, ss)] := ss;
end for;
m:=0;
for i in [1 .. 672] do if cst[i] ne [ ]
then m:=m+1; end if; end for; m;
Orbits(N12161s);

N12162:=Stabiliser(N,[1,2,1,6,2]);
S:=[1,2,1,6,2];
SS:=SN;
SSS:=Setseq(SS);
for i in [1 .. # SS] do
for g in IN do if ts[1]*ts[2]*ts[1]*ts[6]*ts[2]
eq g*ts[Rep(SSS[i])[1]]*ts[Rep(SSS[i])[2]]*ts[Rep(SSS[i])[3]]
*ts[Rep(SSS[i])[4]]*ts[Rep(SSS[i])[5]]
then print SSS[i];
end if; end for; end for;
N12162s:=N12162;
# N12162s;
T12162:=Transversal(N,N12162s);
# T12162;
for i := 1 to # T12162 do
ss := [1, 2, 1, 6, 2]T12162[i];
cst[prodim(1, ts, ss)] := ss;
end for;
m:=0;

```

```

for i in [1 .. 672] do if cst[i] ne [ ]
then m:=m+1; end if; end for; m;
Orbits(N12162s);

N12163:=Stabiliser(N,[1,2,1,6,3]);
S:=[1,2,1,6,3];
SS:=SN;
SSS:=Setseq(SS); for i in [1 .. # SS] do
for g in IN do if ts[1]*ts[2]*ts[1]*ts[6]*ts[3]
eq g*ts[Rep(SSS[i])[1]]*ts[Rep(SSS[i])[2]]*ts[Rep(SSS[i])[3]]
*ts[Rep(SSS[i])[4]]*ts[Rep(SSS[i])[5]]
then print SSS[i];
end if; end for; end for;
N12163s:=N12163;
# N12163s;
T12163:=Transversal(N,N12163s);
# T12163;
for i := 1 to # T12163 do
ss := [1, 2, 1, 6, 3]T12163[i];
cst[prod(1, ts, ss)] := ss;
end for;
m:=0;
for i in [1 .. 672] do if cst[i] ne [ ]
then m:=m+1; end if; end for; m;
Orbits(N12163s);

N12164:=Stabiliser(N,[1,2,1,6,4]);
S:=[1,2,1,6,4];
SS:=SN;
SSS:=Setseq(SS);
for i in [1 .. # SS] do

```

```

for g in IN do if ts[1]*ts[2]*ts[1]*ts[6]*ts[4]
eq g*ts[Rep(SSS[i])[1]]*ts[Rep(SSS[i])[2]]*ts[Rep(SSS[i])[3]]
*ts[Rep(SSS[i])[4]]*ts[Rep(SSS[i])[5]]
then print SSS[i];
end if; end for; end for;
N12164s:=N12164;
# N12164s;
T12164:=Transversal(N,N12164s);
# T12164;
for i := 1 to # T12164 do
ss := [1, 2, 1, 6, 4]T12164[i];
cst[prodim(1, ts, ss)] := ss;
end for;
m:=0;
for i in [1 .. 672] do if cst[i] ne [ ]
then m:=m+1; end if; end for; m;
Orbits(N12164s);

N12165:=Stabiliser(N,[1,2,1,6,5]);
S:=[1,2,1,6,5];
SS:=SN;
SSS:=Setseq(SS);
for i in [1 .. # SS] do for g in IN do if ts[1]*ts[2]*ts[1]*ts[6]*ts[5]
eq g*ts[Rep(SSS[i])[1]]*ts[Rep(SSS[i])[2]]*ts[Rep(SSS[i])[3]]
*ts[Rep(SSS[i])[4]]*ts[Rep(SSS[i])[5]]
then print SSS[i];
end if; end for; end for;
N12165s:=N12165;
# N12165s;
T12165:=Transversal(N,N12165s);
# T12165;

```

```

for i := 1 to # T12165 do
ss := [1, 2, 1, 6, 5]T12165[i];
cst[prodim(1, ts, ss)] := ss;
end for;
m:=0;
for i in [1 .. 672] do if cst[i] ne [ ]
then m:=m+1; end if; end for; m;
Orbits(N12165s);

N12167:=Stabiliser(N,[1,2,1,6,7]);
S:=[1,2,1,6,7];
SS:=SN;
SSS:=Setseq(SS); for i in [1 .. # SS] do
for g in IN do if ts[1]*ts[2]*ts[1]*ts[6]*ts[7]
eq g*ts[Rep(SSS[i])[1]]*ts[Rep(SSS[i])[2]]*ts[Rep(SSS[i])[3]]
*ts[Rep(SSS[i])[4]]*ts[Rep(SSS[i])[5]]
then print SSS[i];
end if; end for; end for;
N12167s:=N12167;
# N12167s;
T12167:=Transversal(N,N12167s);
# T12167;
for i := 1 to # T12167 do
ss := [1, 2, 1, 6, 7]T12167[i];
cst[prodim(1, ts, ss)] := ss;
end for;
m:=0;
for i in [1 .. 672] do if cst[i] ne [ ]
then m:=m+1; end if; end for; m;
Orbits(N12167s);

```

```

N12168:=Stabiliser(N,[1,2,1,6,8]);
S:=[1,2,1,6,8];
SS:=S^N;
SSS:=Setseq(SS); for i in [1 .. # SS] do
for g in IN do if ts[1]*ts[2]*ts[1]*ts[6]*ts[8]
eq g*ts[Rep(SSS[i])[1]]*ts[Rep(SSS[i])[2]]*ts[Rep(SSS[i])[3]]
*ts[Rep(SSS[i])[4]]*ts[Rep(SSS[i])[5]]
then print SSS[i];
end if; end for; end for;
N12168s:=N12168;
# N12168s;
T12168:=Transversal(N,N12168s);
# T12168;
for i := 1 to # T12168 do
ss := [1, 2, 1, 6, 8]^{T12168[i]};
cst[prodim(1, ts, ss)] := ss;
end for;
m:=0;
for i in [1 .. 672] do if cst[i] ne [ ]
then m:=m+1; end if; end for; m;
Orbits(N12168s);

N12169:=Stabiliser(N,[1,2,1,6,9]);
S:=[1,2,1,6,9];
SS:=S^N;
SSS:=Setseq(SS);
for i in [1 .. # SS] do
for g in IN do if ts[1]*ts[2]*ts[1]*ts[6]*ts[9]
eq g*ts[Rep(SSS[i])[1]]*ts[Rep(SSS[i])[2]]*ts[Rep(SSS[i])[3]]
*ts[Rep(SSS[i])[4]]*ts[Rep(SSS[i])[5]]
then print SSS[i];

```

```

end if; end for; end for;
N12169s:=N12169;
# N12169s;
T12169:=Transversal(N,N12169s);
# T12169;
for i := 1 to # T12169 do
ss := [1, 2, 1, 6, 9]T12169[i];
cst[prodim(1, ts, ss)] := ss;
end for;
m:=0;
for i in [1 .. 672] do if cst[i] ne [ ]
then m:=m+1; end if; end for; m;
Orbits(N12169s);

N121610:=Stabiliser(N,[1,2,1,6,10]);
S:=[1,2,1,6,10];
SS:=SN;
SSS:=Setseq(SS);
for i in [1 .. # SSS] do
for g in IN do if ts[1]*ts[2]*ts[1]*ts[6]*ts[10]
eq g*ts[Rep(SSS[i])[1]]*ts[Rep(SSS[i])[2]]*ts[Rep(SSS[i])[3]]
*ts[Rep(SSS[i])[4]]*ts[Rep(SSS[i])[5]]
then print SSS[i];
end if; end for; end for;
N121610s:=N121610;
# N121610s;
T121610:=Transversal(N,N121610s);
# T121610;
for i := 1 to # T121610 do
ss := [1, 2, 1, 6, 10]T121610[i];
cst[prodim(1, ts, ss)] := ss;

```

```

end for;
m:=0;
for i in [1 .. 672] do if cst[i] ne [ ]
then m:=m+1; end if; end for; m;
Orbits(N121610s);

N121611:=Stabiliser(N,[1,2,1,6,11]);
S:=[1,2,1,6,11];
SS:=SN;
SSS:=Setseq(SS);
for i in [1 .. # SS] do
for g in IN do if ts[1]*ts[2]*ts[1]*ts[6]*ts[11]
eq g*ts[Rep(SSS[i])[1]]*ts[Rep(SSS[i])[2]]*ts[Rep(SSS[i])[3]]
*ts[Rep(SSS[i])[4]]*ts[Rep(SSS[i])[5]]
then print SSS[i];
end if; end for; end for;
N121611s:=N121611;
# N121611s;
T121611:=Transversal(N,N121611s);
# T121611;
for i := 1 to # T121611 do
ss := [1, 2, 1, 6, 11]T121611[i];
cst[prodim(1, ts, ss)] := ss;
end for;
m:=0;
for i in [1 .. 672] do if cst[i] ne [ ]
then m:=m+1; end if; end for; m;
Orbits(N121611s);

N121612:=Stabiliser(N,[1,2,1,6,12]);
S:=[1,2,1,6,12];

```



```

SS:=SN;
SSS:=Setseq(SS);
for i in [1 .. # SS] do
for g in IN do if ts[1]*ts[2]*ts[1]*ts[6]*ts[12]
eq g*ts[Rep(SSS[i])[1]]*ts[Rep(SSS[i])[2]]*ts[Rep(SSS[i])[3]]
*ts[Rep(SSS[i])[4]]*ts[Rep(SSS[i])[5]]
then print SSS[i];
end if; end for; end for;
N121612s:=N121612;
# N121612s;
T121612:=Transversal(N,N121612s);
# T121612;
for i := 1 to # T121612 do
ss := [1, 2, 1, 6, 12]T121612[i];
cst[prodim(1, ts, ss)] := ss;
end for;
m:=0;
for i in [1 .. 672] do if cst[i] ne [ ]
then m:=m+1; end if; end for; m;
Orbits(N121612s);

N121613:=Stabiliser(N,[1,2,1,6,13]);
S:=[1,2,1,6,13];
SS:=SN;
SSS:=Setseq(SS);
for i in [1 .. # SS] do
for g in IN do if ts[1]*ts[2]*ts[1]*ts[6]*ts[13]
eq g*ts[Rep(SSS[i])[1]]*ts[Rep(SSS[i])[2]]*ts[Rep(SSS[i])[3]]
*ts[Rep(SSS[i])[4]]*ts[Rep(SSS[i])[5]]
then print SSS[i];
end if; end for; end for;

```

```

N121613s:=N121613;
# N121613s;
T121613:=Transversal(N,N121613s);
# T121613;
for i := 1 to # T121613 do
ss := [1, 2, 1, 6, 13]T121613[i];
cst[prodim(1, ts, ss)] := ss;
end for;
m:=0;
for i in [1 .. 672] do if cst[i] ne [ ]
then m:=m+1; end if; end for; m;
Orbits(N121613s);

N121614:=Stabiliser(N,[1,2,1,6,14]);
S:=[1,2,1,6,14];
SS:=SN;
SSS:=Setseq(SS);
for i in [1 .. # SS] do
for g in IN do if ts[1]*ts[2]*ts[1]*ts[6]*ts[14]
eq g*ts[Rep(SSS[i])[1]]*ts[Rep(SSS[i])[2]]*ts[Rep(SSS[i])[3]]
*ts[Rep(SSS[i])[4]]*ts[Rep(SSS[i])[5]]
then print SSS[i];
end if; end for; end for;
N121614s:=N121614;
# N121614s;
T121614:=Transversal(N,N121614s);
# T121614;
for i := 1 to # T121614 do
ss := [1, 2, 1, 6, 14]T121614[i];
cst[prodim(1, ts, ss)] := ss;
end for;

```

```

m:=0;
for i in [1 .. 672] do if cst[i] ne [ ]
then m:=m+1; end if; end for; m;
Orbits(N121614s);

N121615:=Stabiliser(N,[1,2,1,6,15]);
S:=[1,2,1,6,15];
SS:=SN;
SSS:=Setseq(SS); for i in [1 .. # SS] do
for g in IN do if ts[1]*ts[2]*ts[1]*ts[6]*ts[15]
eq g*ts[Rep(SSS[i])[1]]*ts[Rep(SSS[i])[2]]*ts[Rep(SSS[i])[3]]
*ts[Rep(SSS[i])[4]]*ts[Rep(SSS[i])[5]]
then print SSS[i];
end if; end for; end for;
N121615s:=N121615;
# N121615s;
T121615:=Transversal(N,N121615s);
# T121615;
for i := 1 to #T121615 do
ss := [1, 2, 1, 6, 15]T121615[i];
cst[prodim(1, ts, ss)] := ss;
end for;
m:=0;
for i in [1 .. 672] do if cst[i] ne [ ]
then m:=m+1; end if; end for; m;
Orbits(N121615s);

N124141:=Stabiliser(N,[1,2,4,14,1]);
S:=[1,2,4,14,1];
SS:=SN;
SSS:=Setseq(SS); for i in [1 .. # SS] do

```

```

for g in IN do if ts[1]*ts[2]*ts[4]*ts[14]*ts[1]
eq g*ts[Rep(SSS[i])[1]]*ts[Rep(SSS[i])[2]]*ts[Rep(SSS[i])[3]]
*ts[Rep(SSS[i])[4]]*ts[Rep(SSS[i])[5]]
then print SSS[i];
end if; end for; end for;
N124141s:=N124141;
# N124141s; T124141:=Transversal(N,N124141s);
# T124141;
for i := 1 to # T124141 do
ss := [1, 2, 4, 14, 1]T124141[i];
cst[prodim(1, ts, ss)] := ss;
end for;
m:=0;
for i in [1 .. 672] do if cst[i] ne [ ]
then m:=m+1; end if; end for; m;
Orbits(N124141s);

N124142:=Stabiliser(N,[1,2,4,14,2]);
S:=[1,2,4,14,2];
SS:=SN;
SSS:=Setseq(SS);
for i in [1 .. # SS] do
for g in IN do if ts[1]*ts[2]*ts[4]*ts[14]*ts[2]
eq g*ts[Rep(SSS[i])[1]]*ts[Rep(SSS[i])[2]]*ts[Rep(SSS[i])[3]]
*ts[Rep(SSS[i])[4]]*ts[Rep(SSS[i])[5]]
then print SSS[i];
end if; end for; end for;
N124142s:=N124142;
# N124142s;
T124142:=Transversal(N,N124142s);
# T124142;

```

```

for i := 1 to #T124142 do
ss := [1, 2, 4, 14, 2]T124142[i];
cst[prodim(1, ts, ss)] := ss;
end for;
m:=0;
for i in [1 .. 672] do if cst[i] ne [ ]
then m:=m+1; end if; end for; m;
Orbits(N124142);

N124143:=Stabiliser(N,[1,2,4,14,3]);
S:=[1,2,4,14,3];
SS:=SN;
SSS:=Setseq(SS);
for i in [1 .. # SS] do
for g in IN do if ts[1]*ts[2]*ts[4]*ts[14]*ts[3]
eq g*ts[Rep(SSS[i])[1]]*ts[Rep(SSS[i])[2]]*ts[Rep(SSS[i])[3]]
*ts[Rep(SSS[i])[4]]*ts[Rep(SSS[i])[5]]
then print SSS[i];
end if; end for; end for;
N124143s:=N124143;
# N124143s;
T124143:=Transversal(N,N124143s);
# T124143;
for i := 1 to # T124143 do
ss := [1, 2, 4, 14, 3]T124143[i];
cst[prodim(1, ts, ss)] := ss;
end for;
m:=0;
for i in [1 .. 672] do if cst[i] ne [ ]
then m:=m+1; end if; end for; m;
Orbits(N124143s);

```

```

N124144:=Stabiliser(N,[1,2,4,14,4]);
S:=[1,2,4,14,4];
SS:=S^N;
SSS:=Setseq(SS); for i in [1 .. # SS] do
for g in IN do if ts[1]*ts[2]*ts[4]*ts[14]*ts[4]
eq g*ts[Rep(SSS[i])[1]]*ts[Rep(SSS[i])[2]]*ts[Rep(SSS[i])[3]]
*ts[Rep(SSS[i])[4]]*ts[Rep(SSS[i])[5]]
then print SSS[i];
end if; end for; end for;
N124144s:=N124144;
# N124144s;
T124144:=Transversal(N,N124144s);
# T124144;
for i := 1 to # T124144 do
ss := [1, 2, 4, 14, 4]^T124144[i];
cst[prodim(1, ts, ss)] := ss;
end for;
m:=0;
for i in [1 .. 672] do if cst[i] ne [ ]
then m:=m+1; end if; end for; m;
Orbits(N124144s);

```

```

N124145:=Stabiliser(N,[1,2,4,14,5]);
S:=[1,2,4,14,5];
SS:=S^N;
SSS:=Setseq(SS);
for i in [1 .. # SS] do
for g in IN do if ts[1]*ts[2]*ts[4]*ts[14]*ts[5]
eq g*ts[Rep(SSS[i])[1]]*ts[Rep(SSS[i])[2]]*ts[Rep(SSS[i])[3]]
*ts[Rep(SSS[i])[4]]*ts[Rep(SSS[i])[5]]

```

```

then print SSS[i];
end if; end for; end for;
N124145s:=N124145;
# N124145s;
T124145:=Transversal(N,N124145s);
# T124145;
for i := 1 to # T124145 do
ss := [1, 2, 4, 14, 5]T124145[i];
cst[prodim(1, ts, ss)] := ss;
end for;
m:=0;
for i in [1 .. 672] do if cst[i] ne [ ]
then m:=m+1; end if; end for; m;
Orbits(N124145s);

N124146:=Stabiliser(N,[1,2,4,14,6]);
S:=[1,2,4,14,6];
SS:=SN;
SSS:=Setseq(SS);
for i in [1 .. # SS] do
for g in IN do if ts[1]*ts[2]*ts[4]*ts[14]*ts[6]
eq g*ts[Rep(SSS[i])[1]]*ts[Rep(SSS[i])[2]]*ts[Rep(SSS[i])[3]]
*ts[Rep(SSS[i])[4]]*ts[Rep(SSS[i])[5]]
then print SSS[i];
end if; end for; end for;
N124146s:=N124146;
# N124146s;
T124146:=Transversal(N,N124146s);
# T124146;
for i := 1 to # T124146 do
ss := [1, 2, 4, 14, 6]T124146[i];

```

```

cst[prodim(1, ts, ss)] := ss;
end for;
m:=0;
for i in [1 .. 672] do if cst[i] ne [ ]
then m:=m+1; end if; end for; m;
Orbits(N124146s);

N124147:=Stabiliser(N,[1,2,4,14,7]);
S:=[1,2,4,14,7];
SS:=SN;
SSS:=Setseq(SS);
for i in [1 .. # SS] do
for g in IN do if ts[1]*ts[2]*ts[4]*ts[14]*ts[7]
eq g*ts[Rep(SSS[i])[1]]*ts[Rep(SSS[i])[2]]*ts[Rep(SSS[i])[3]]
*ts[Rep(SSS[i])[4]]*ts[Rep(SSS[i])[5]]
then print SSS[i];
end if; end for; end for;
N124147s:=N124147;
# N124147s;
T124147:=Transversal(N,N124147s);
# T124147;
for i := 1 to # T124147 do
ss := [1, 2, 4, 14, 7]T124147[i];
cst[prodim(1, ts, ss)] := ss;
end for;
m:=0;
for i in [1 .. 672] do if cst[i] ne [ ]
then m:=m+1; end if; end for; m;
Orbits(N124147s);

N124148:=Stabiliser(N,[1,2,4,14,8]);

```



```

S:=[1,2,4,14,8];
SS:=SN;
SSS:=Setseq(SS);
for i in [1 .. # SS] do
for g in IN do if ts[1]*ts[2]*ts[4]*ts[14]*ts[8]
eq g*ts[Rep(SSS[i])[1]]*ts[Rep(SSS[i])[2]]*ts[Rep(SSS[i])[3]]
*ts[Rep(SSS[i])[4]]*ts[Rep(SSS[i])[5]]
then print SSS[i];
end if; end for; end for;
N124148s:=N124148;
# N124148s;
T124148:=Transversal(N,N124148s);
# T124148;
for i := 1 to # T124148 do
ss := [1, 2, 4, 14, 8]T124148[i];
cst[prodim(1, ts, ss)] := ss;
end for;
m:=0;
for i in [1 .. 672] do if cst[i] ne [ ]
then m:=m+1; end if; end for; m;
Orbits(N124148s);

N124149:=Stabiliser(N,[1,2,4,14,9]);
S:=[1,2,4,14,9];
SS:=SN;
SSS:=Setseq(SS);
for i in [1 .. # SS] do
for g in IN do if ts[1]*ts[2]*ts[4]*ts[14]*ts[9]
eq g*ts[Rep(SSS[i])[1]]*ts[Rep(SSS[i])[2]]*ts[Rep(SSS[i])[3]]
*ts[Rep(SSS[i])[4]]*ts[Rep(SSS[i])[5]]
then print SSS[i];

```

```

end if; end for; end for;
N124149s:=N124149;
# N124149s;
T124149:=Transversal(N,N124149s);
# T124149;
for i := 1 to # T124149 do
ss := [1, 2, 4, 14, 9]T124149[i];
cst[prodim(1, ts, ss)] := ss;
end for;
m:=0;
for i in [1 .. 672] do if cst[i] ne [ ]
then m:=m+1; end if; end for; m;
Orbits(N124149s);

N1241410:=Stabiliser(N,[1,2,4,14,10]);
S:=[1,2,4,14,10];
SS:=SN;
SSS:=Setseq(SS);
for i in [1 .. # SSS] do
for g in IN do if ts[1]*ts[2]*ts[4]*ts[14]*ts[10]
eq g*ts[Rep(SSS[i])[1]]*ts[Rep(SSS[i])[2]]*ts[Rep(SSS[i])[3]]
*ts[Rep(SSS[i])[4]]*ts[Rep(SSS[i])[5]]
then print SSS[i];
end if; end for; end for;
N1241410s:=N1241410;
# N1241410s;
T1241410:=Transversal(N,N1241410s);
# T1241410;
for i := 1 to # T1241410 do
ss := [1, 2, 4, 14, 10]T1241410[i];
cst[prodim(1, ts, ss)] := ss;

```

```

end for;
m:=0;
for i in [1 .. 672] do if cst[i] ne [ ]
then m:=m+1; end if; end for; m;
Orbits(N1241410s);

N1241411:=Stabiliser(N,[1,2,4,14,11]);
S:=[1,2,4,14,11];
SS:=SN;
SSS:=Setseq(SS);
for i in [1 .. # SS] do
for g in IN do if ts[1]*ts[2]*ts[4]*ts[14]*ts[11]
eq g*ts[Rep(SSS[i])[1]]*ts[Rep(SSS[i])[2]]*ts[Rep(SSS[i])[3]]
*ts[Rep(SSS[i])[4]]*ts[Rep(SSS[i])[5]]
then print SSS[i];
end if; end for; end for;
N1241411s:=N1241411;
# N1241411s;
T1241411:=Transversal(N,N1241411s);
# T1241411;
for i := 1 to # T1241411 do
ss := [1, 2, 4, 14, 11]T1241411[i];
cst[prodim(1, ts, ss)] := ss;
end for;
m:=0;
for i in [1 .. 672] do if cst[i] ne [ ]
then m:=m+1; end if; end for; m;
Orbits(N1241411s);

N1241412:=Stabiliser(N,[1,2,4,14,12]);
S:=[1,2,4,14,12];

```

```

SS:=SN;
SSS:=Setseq(SS);
for i in [1 .. # SS] do
for g in IN do if ts[1]*ts[2]*ts[4]*ts[14]*ts[12]
eq g*ts[Rep(SSS[i])[1]]*ts[Rep(SSS[i])[2]]*ts[Rep(SSS[i])[3]]
*ts[Rep(SSS[i])[4]]*ts[Rep(SSS[i])[5]]
then print SSS[i];
end if; end for; end for;
N1241412s:=N1241412;
# N1241412s;
T1241412:=Transversal(N,N1241412s);
# T1241412;
for i := 1 to # T1241412 do
ss := [1, 2, 4, 14, 12]T1241412[i];
cst[prodim(1, ts, ss)] := ss;
end for;
m:=0;
for i in [1 .. 672] do if cst[i] ne [ ]
then m:=m+1; end if; end for; m;
Orbits(N1241412s);

N1241413:=Stabiliser(N,[1,2,4,14,13]);
S:=[1,2,4,14,13];
SS:=SN;
SSS:=Setseq(SS);
for i in [1 .. # SS] do
for g in IN do if ts[1]*ts[2]*ts[4]*ts[14]*ts[13]
eq g*ts[Rep(SSS[i])[1]]*ts[Rep(SSS[i])[2]]*ts[Rep(SSS[i])[3]]
*ts[Rep(SSS[i])[4]]*ts[Rep(SSS[i])[5]]
then print SSS[i];
end if; end for; end for;

```

```

N1241413s:=N1241413;
# N1241413s;
T1241413:=Transversal(N,N1241413s);
# T1241413;
for i := 1 to # T1241413 do
ss := [1, 2, 4, 14, 13]T1241413[i];
cst[prodim(1, ts, ss)] := ss;
end for;
m:=0;
for i in [1 .. 672] do if cst[i] ne [ ]
then m:=m+1; end if; end for; m;
Orbits(N1241413s);

N1241415:=Stabiliser(N,[1,2,4,14,15]);
S:=[1,2,4,14,15];
SS:=SN;
SSS:=Setseq(SS);
for i in [1 .. # SS] do
for g in IN do if ts[1]*ts[2]*ts[4]*ts[14]*ts[15]
eq g*ts[Rep(SSS[i])[1]]*ts[Rep(SSS[i])[2]]*ts[Rep(SSS[i])[3]]
*ts[Rep(SSS[i])[4]]*ts[Rep(SSS[i])[5]]
then print SSS[i];
end if; end for; end for;
N1241415s:=N1241415;
# N1241415s;
T1241415:=Transversal(N,N1241415s);
# T1241415;
for i := 1 to # T1241415 do
ss := [1, 2, 4, 14, 15]T1241415[i];
cst[prodim(1, ts, ss)] := ss;
end for;

```

```

m:=0;
for i in [1 .. 672] do if cst[i] ne [ ]
then m:=m+1; end if; end for; m;
Orbits(N1241415s);

N129151:=Stabiliser(N,[1,2,9,15,1]);
S:=[1,2,9,15,1];
SS:=SN;
SSS:=Setseq(SS);
for i in [1 .. # SS] do
for g in IN do if ts[1]*ts[2]*ts[9]*ts[15]*ts[1]
eq g*ts[Rep(SSS[i])[1]]*ts[Rep(SSS[i])[2]]*ts[Rep(SSS[i])[3]]
*ts[Rep(SSS[i])[4]]*ts[Rep(SSS[i])[5]]
then print SSS[i];
end if; end for; end for;
N129151s:=N129151;
# N129151s;
T129151:=Transversal(N,N129151s);
# T129151;
for i := 1 to # T129151 do
ss := [1, 2, 9, 15, 1]T129151[i];
cst[prodim(1, ts, ss)] := ss;
end for;
m:=0;
for i in [1 .. 672] do if cst[i] ne [ ]
then m:=m+1; end if; end for; m;
Orbits(N129151s);

N129152:=Stabiliser(N,[1,2,9,15,2]);
S:=[1,2,9,15,2];
SS:=SN;

```

```

SSS:=Setseq(SS);
for i in [1 .. # SS] do
for g in IN do if ts[1]*ts[2]*ts[9]*ts[15]*ts[2]
eq g*ts[Rep(SSS[i])[1]]*ts[Rep(SSS[i])[2]]*ts[Rep(SSS[i])[3]]
*ts[Rep(SSS[i])[4]]*ts[Rep(SSS[i])[5]]
then print SSS[i];
end if; end for; end for;
N129152s:=N129152;
# N129152s;
T129152:=Transversal(N,N129152s);
# T129152;
for i := 1 to # T129152 do
ss := [1, 2, 9, 15, 2]T129152[i];
cst[prodim(1, ts, ss)] := ss;
end for;
m:=0;
for i in [1 .. 672] do if cst[i] ne [ ]
then m:=m+1; end if; end for; m;
Orbits(N129152s);

N129153:=Stabiliser(N,[1,2,9,15,3]);
S:=[1,2,9,15,3];
SS:=SN;
SSS:=Setseq(SS);
for i in [1 .. # SS] do
for g in IN do if ts[1]*ts[2]*ts[9]*ts[15]*ts[3]
eq g*ts[Rep(SSS[i])[1]]*ts[Rep(SSS[i])[2]]*ts[Rep(SSS[i])[3]]
*ts[Rep(SSS[i])[4]]*ts[Rep(SSS[i])[5]]
then print SSS[i];
end if; end for; end for;
N129153s:=N129153;

```

```

# N129153s;
T129153:=Transversal(N,N129153s);
# T129153;
for i := 1 to # T129153 do
ss := [1, 2, 9, 15, 3]T129153[i];
cst[prodim(1, ts, ss)] := ss;
end for;
m:=0;
for i in [1 .. 672] do if cst[i] ne [ ]
then m:=m+1; end if; end for; m;
Orbits(N129153s);

N129154:=Stabiliser(N,[1,2,9,15,4]);
S:=[1,2,9,15,4];
SS:=SN;
SSS:=Setseq(SS);
for i in [1 .. # SS] do
for g in IN do if ts[1]*ts[2]*ts[9]*ts[15]*ts[4]
eq g*ts[Rep(SSS[i])[1]]*ts[Rep(SSS[i])[2]]*ts[Rep(SSS[i])[3]]
*ts[Rep(SSS[i])[4]]*ts[Rep(SSS[i])[5]]
then print SSS[i];
end if; end for; end for;
N129154s:=N129154;
# N129154s;
T129154:=Transversal(N,N129154s);
# T129154;
for i := 1 to # T129154 do
ss := [1, 2, 9, 15, 4]T129154[i];
cst[prodim(1, ts, ss)] := ss;
end for;
m:=0;

```



```

for i in [1 .. 672] do if cst[i] ne [ ]
then m:=m+1; end if; end for; m;
Orbits(N129154s);

N1291510:=Stabiliser(N,[1,2,9,15,10]);
S:=[1,2,9,15,10];
SS:=SN;
SSS:=Setseq(SS);
for i in [1 .. # SS] do
for g in IN do if ts[1]*ts[2]*ts[9]*ts[15]*ts[10]
eq g*ts[Rep(SSS[i])[1]]*ts[Rep(SSS[i])[2]]*ts[Rep(SSS[i])[3]]
*ts[Rep(SSS[i])[4]]*ts[Rep(SSS[i])[5]]
then print SSS[i];
end if; end for; end for;
N1291510s:=N1291510;
# N1291510s;
T1291510:=Transversal(N,N1291510s);
# T1291510;
for i := 1 to # T1291510 do
ss := [1, 2, 9, 15, 10]T1291510[i];
cst[prodim(1, ts, ss)] := ss;
end for;
m:=0;
for i in [1 .. 672] do if cst[i] ne [ ]
then m:=m+1; end if; end for; m;
Orbits(N1291510s);

N1291513:=Stabiliser(N,[1,2,9,15,13]);
S:=[1,2,9,15,13];
SS:=SN;
SSS:=Setseq(SS);

```

```

for i in [1 .. # SS] do
fodo if ts[1]*ts[2]*ts[9]*ts[15]*ts[13]
eq g*ts[Rep(SSS[i])[1]]*ts[Rep(SSS[i])[2]]*ts[Rep(SSS[i])[3]]
*ts[Rep(SSS[i])[4]]*ts[Rep(SSS[i])[5]]
then print SSS[i];
end if; end for; end for;
N1291513s:=N1291513;
# N1291513s;
T1291513:=Transversal(N,N1291513s);
# T1291513;
for i := 1 to # T1291513 do
ss := [1, 2, 9, 15, 13]T1291513[i];
cst[prodim(1, ts, ss)] := ss;
end for;
m:=0;
for i in [1 .. 672] do if cst[i] ne [ ]
then m:=m+1; end if; end for; m;
Orbits(N1291513s);

N131111:=Stabiliser(N,[1,3,1,11,1]);
S:=[1,3,1,11,1];
SS:=SN;
SSS:=Setseq(SS);
for i in [1 .. # SS] do
for g in IN do if ts[1]*ts[3]*ts[1]*ts[11]*ts[1]
eq g*ts[Rep(SSS[i])[1]]*ts[Rep(SSS[i])[2]]*ts[Rep(SSS[i])[3]]
*ts[Rep(SSS[i])[4]]*ts[Rep(SSS[i])[5]]
then print SSS[i];
end if; end for; end for;
N131111s:=N131111;
# N131111s;

```

```

T131111:=Transversal(N,N131111s);
# T131111;
for i := 1 to # T131111 do
ss := [1, 3, 1, 11, 1]T131111[i];
cst[prodim(1, ts, ss)] := ss; end for;
m:=0;
for i in [1 .. 672] do if cst[i] ne [ ]
then m:=m+1; end if; end for; m;
Orbits(N131111s);

N135111:=Stabiliser(N,[1,3,5,11,1]);
S:=[1,3,5,11,1];
SS:=SN;
SSS:=Setseq(SS);
for i in [1 .. # SS] do
for g in IN do if ts[1]*ts[3]*ts[5]*ts[11]*ts[1]
eq g*ts[Rep(SSS[i])[1]]*ts[Rep(SSS[i])[2]]*ts[Rep(SSS[i])[3]]
*ts[Rep(SSS[i])[4]]*ts[Rep(SSS[i])[5]]
then print SSS[i];
end if; end for; end for;
N135111s:=N135111;
# N135111s;
T135111:=Transversal(N,N135111s);
# T135111;
for i := 1 to # T135111 do
ss := [1, 3, 5, 11, 1]T135111[i];
cst[prodim(1, ts, ss)] := ss;
end for;
m:=0;
for i in [1 .. 672] do if cst[i] ne [ ]
then m:=m+1; end if; end for; m;

```

```

Orbits(N135111s);

N135112:=Stabiliser(N,[1,3,5,11,2]);
S:=[1,3,5,11,2];
SS:=SN;
SSS:=Setseq(SS);
for i in [1 .. # SS] do
for g in IN do if ts[1]*ts[3]*ts[5]*ts[11]*ts[2]
eq g*ts[Rep(SSS[i])[1]]*ts[Rep(SSS[i])[2]]*ts[Rep(SSS[i])[3]]
*ts[Rep(SSS[i])[4]]*ts[Rep(SSS[i])[5]]
then print SSS[i];
end if; end for; end for;
N135112s:=N135112;
# N135112s;
T135112:=Transversal(N,N135112s);
# T135112;
for i := 1 to # T135112 do
ss := [1, 3, 5, 11, 2]T135112[i];
cst[prodim(1, ts, ss)] := ss;
end for;
m:=0;
for i in [1 .. 672] do if cst[i] ne [ ]
then m:=m+1; end if; end for; m;
Orbits(N135112s);

N135114:=Stabiliser(N,[1,3,5,11,4]);
S:=[1,3,5,11,4];
SS:=SN;
SSS:=Setseq(SS);
for i in [1 .. # SS] do
for g in IN do if ts[1]*ts[3]*ts[5]*ts[11]*ts[4]

```

```

eq g*ts[Rep(SSS[i])[1]]*ts[Rep(SSS[i])[2]]*ts[Rep(SSS[i])[3]]
*ts[Rep(SSS[i])[4]]*ts[Rep(SSS[i])[5]]
then print SSS[i];
end if; end for; end for;
N135114s:=N135114;
# N135114s;
T135114:=Transversal(N,N135114s);
# T135114;
for i := 1 to # T135114 do
ss := [1, 3, 5, 11, 4]T135114[i];
cst[prodim(1, ts, ss)] := ss;
end for;
m:=0;
for i in [1 .. 672] do if cst[i] ne [ ]
then m:=m+1; end if; end for; m;
Orbits(N135114s);

N1351114:=Stabiliser(N,[1,3,5,11,14]);
S:=[1,3,5,11,14];
SS:=SN;
SSS:=Setseq(SS); for i in [1.. # SS] do
for g in IN do if ts[1]*ts[3]*ts[5]*ts[11]*ts[14]
eq g*ts[Rep(SSS[i])[1]]*ts[Rep(SSS[i])[2]]*ts[Rep(SSS[i])[3]]
*ts[Rep(SSS[i])[4]]*ts[Rep(SSS[i])[5]]
then print SSS[i];
end if; end for; end for;
N1351114s:=N1351114;
# N1351114s;
T1351114:=Transversal(N,N1351114s);
# T1351114;
for i := 1 to # T1351114 do

```

```

ss := [1, 3, 5, 11, 14]T1351114[i];
cst[prodim(1, ts, ss)] := ss;
end for;
m:=0;
for i in [1 .. 672] do if cst[i] ne [ ]
then m:=m+1; end if; end for; m;
Orbits(N1351114s);

N1351115:=Stabiliser(N,[1,3,5,11,15]);
S:=[1,3,5,11,15];
SS:=SN;
SSS:=Setseq(SS);
for i in [1 .. # SS] do
for g in IN do if ts[1]*ts[3]*ts[5]*ts[11]*ts[15]
eq g*ts[Rep(SSS[i])[1]]*ts[Rep(SSS[i])[2]]*ts[Rep(SSS[i])[3]]
*ts[Rep(SSS[i])[4]]*ts[Rep(SSS[i])[5]]
then print SSS[i];
end if; end for; end for;
N1351115s:=N1351115;
# N1351115s;
T1351115:=Transversal(N,N1351115s);
# T1351115;
for i := 1 to # T1351115 do
ss := [1, 3, 5, 11, 15]T1351115[i];
cst[prodim(1, ts, ss)] := ss;
end for;
m:=0;
for i in [1 .. 672] do if cst[i] ne [ ]
then m:=m+1; end if; end for; m;
Orbits(N1351115s);

```

Appendix C

Magma Work for

$$(10 \times 10) : ((3 \times 4) : 2)$$

```

S:=Sym(15);
xx:=S!(1, 2, 6, 3, 8, 14, 10, 7, 12, 11, 15, 13, 5, 9, 4);
yy:=S!(2, 7, 8, 9)(3, 10, 5, 11)(4, 12, 13, 6);
N:=sub< S|xx,yy >;
# N;
Stabiliser(N,1);
G< x,y,t >:= Group< x,y,t|y^4, y^-1 * x^-2 * y * x^-1, t^2, (t,y), (y^-1 * x^-1 * t)^4 >;
# G;
f,G1,k:=CosetAction(G,sub< G|x,y >); IN:=sub< G1|f(x), f(y) >;
CompositionFactors(G1);
# DoubleCosets(G,sub< G|x,y >, sub< G|x,y >);
DoubleCosets(G,sub< G|x,y >, sub< G|x,y >);
NN< a,b >:= Group< a,b|b^4, b^-1 * a^-2 * b * a^-1 >; Sch:=SchreierSystem(NN,sub<
NN|Id(NN) >);
ArrayP:=[Id(N): i in [1 .. 60]];
for i in [2 .. 60] do
P:=[Id(N): l in [1 .. # Sch[i]]];
for j in [1..# Sch[i]] do

```

```

if Eltseq(Sch[i])[j] eq 1 then P[j]:=xx; end if;
if Eltseq(Sch[i])[j] eq -1 then P[j]:=xx-1; end if;
if Eltseq(Sch[i])[j] eq 2 then P[j]:=yy; end if;
if Eltseq(Sch[i])[j] eq -2 then P[j]:=yy-1; end if;
end for;
PP:=Id(N);
for k in [1 .. # P] do
PP:=PP*P[k]; end for;
ArrayP[i]:=PP
; end for;
for i in [1 .. 60] do if ArrayP[i] eq N!(2, 7, 8, 9)(3, 10, 5, 11)(4, 12, 13, 6)
then Sch[i];
end if; end for;
prodim := function(pt, Q, I)
v:=pt;
for i in I do
v:=v(Q[i]);
end for;
return v;
end function;

ts := [ Id(G1): i in [1 .. 15] ];
ts[1]:=f(t); ts[2]:=f(tx); ts[3]:=f(t(x3));
ts[4]:=f(t(x14)); ts[5]:=f(t(x12));
ts[6]:=f(t(x2));ts[7]:=f(t(x7));
ts[8]:=f(t(x4)); ts[9]:=f(t(x13));
ts[10]:=f(t(x6)); ts[11]:=f(t(x9));
ts[12]:=f(t(x8));ts[13]:=f(t(x11));
ts[14]:=f(t(x5)); ts[15]:=f(t(x10));

cst:=[null : i in [1 .. Index(G,sub< G|x, y >)]]

```



```

where null is [Integers( ) | ];
for i := 1 to 15 do
cst[prodim(1, ts, [i])]:= [i];
end for;
m:=0;
for i in [1 .. 40] do if cst[i] ne [ ]
then m:=m+1; end if; end for; m;

N1:=Stabiliser(N,1);
S:=[1];
SS:=SN;
SSS:=Setseq(SS);
for i in [1 .. # SS] do
for g in IN do if ts[1]
eq g*ts[Rep(SSS[i])[1]]
then print SSS[i];
end if; end for; end for;
N1s:=N1;
# N1s;
T1:=Transversal(N,N1s);
# T1;
Orbits(N1s);

N114:=Stabiliser(N,[1,14]);
S:=[1,14];
SS:=SN;
SSS:=Setseq(SS);
for i in [1 .. # SS] do
for g in IN do if ts[1]*ts[14]
eq g*ts[Rep(SSS[i])[1]]*ts[Rep(SSS[i])[2]]
then print SSS[i];

```

```

end if; end for; end for;
N114s:=N114;
# N114s;
T114:=Transversal(N,N114s);
# T114;
for i := 1 to 15 do
cst[prodim(1, ts, [i])]:=i];
end for;
m:=0;
for i in [1..40] do if cst[i] ne [ ]
then m:=m+1; end if; end for; m;
Orbits(N114s);
for m,n in IN do if ts[1]*ts[14] eq m * (ts[1])n
then m,n; end if; end for;

      for i in [1 .. 30] do i, cst[i]; end for;

N115:=Stabiliser(N,[1,15]);
S:=[1,15];
SS:=SN;
SSS:=Setseq(SS);
for i in [1 .. # SS] do
for g in IN do if ts[1]*ts[15]
eq g*ts[Rep(SSS[i])[1]]*ts[Rep(SSS[i])[2]]
then print SSS[i];
end if; end for; end for;
N115s:=N115;
# N115s;
T115:=Transversal(N,N115s);
# T115;
for i := 1 to # T115 do

```

```

ss := [1, 15]T115[i];
cst[prodim(1, ts, ss)] := ss;
end for;
m:=0;
for i in [1..40] do if cst[i] ne [ ]
then m:=m+1; end if; end for; m;
Orbits(N115s);
for m,n in IN do if ts[1]*ts[15] eq m * (ts[1] * ts[14])n
then m,n; end if; end for;

N12:=Stabiliser(N,[1,2]);
S:=[1,2];
SS:=SN;
SSS:=Setseq(SS);
for i in [1 .. # SS] do
for g in IN do if ts[1]*ts[2]
eq g*ts[Rep(SSS[i])[1]]*ts[Rep(SSS[i])[2]]
then print SSS[i];
end if; end for; end for;
N12s:=N12;
# N12s;
T12:=Transversal(N,N12s);
# T12;
for i := 1 to # T12 do
ss := [1, 2]T12[i];
cst[prodim(1, ts, ss)] := ss;
end for;
m:=0;
for i in [1..40] do if cst[i] ne [ ]
then m:=m+1; end if; end for; m;

```

```

N13:=Stabiliser(N,[1,3]);
S:=[1,3];
SS:=S^N;
SSS:=Setseq(SS);
for i in [1 .. # SS] do
for g in IN do if ts[1]*ts[3]
eq g*ts[Rep(SSS[i])[1]]*ts[Rep(SSS[i])[2]]
then print SSS[i];
end if; end for; end for;
N13s:=N13;
# N13s;
T13:=Transversal(N,N13s);
# T13;
for i := 1 to # T13 do
ss := [1, 3]^{T13[i]};
cst[prodim(1, ts, ss)] := ss;
end for;
m:=0;
for i in [1 .. 40] do if cst[i] ne [ ]
then m:=m+1; end if; end for; m;
Orbits(N13s);

N14:=Stabiliser(N,[1,4]);
S:=[1,4];
SS:=S^N;
SSS:=Setseq(SS);
for i in [1 .. # SS] do
for g in IN do if ts[1]*ts[4]
eq g*ts[Rep(SSS[i])[1]]*ts[Rep(SSS[i])[2]]
then print SSS[i];
end if; end for; end for;

```

```

N14s:=N14;
# N14s;
T14:=Transversal(N,N14s);
# T14;
for i := 1 to # T14 do
ss := [1, 4]T14[i];
cst[prodim(1, ts, ss)] := ss;
end for;
m:=0;
for i in [1 .. 40] do if cst[i] ne [ ]
then m:=m+1; end if; end for; m;
Orbits(N14s);

N1141:=Stabiliser(N,[1,14,1]);
S:=[1,14,1];
SS:=SN;
SSS:=Setseq(SS);
for i in [1 .. # SS] do
for g in IN do if ts[1]*ts[14]*ts[1]
eq g*ts[Rep(SSS[i])[1]]*ts[Rep(SSS[i])[2]]*ts[Rep(SSS[i])[3]]
then print SSS[i];
end if; end for; end for;
N1141s:=N1141;
# N1141s;
T1141:=Transversal(N,N1141s);
# T1141;
for i := 1 to # T1141 do
ss := [1, 14, 1]T1141[i];
cst[prodim(1, ts, ss)] := ss;
end for;
m:=0;

```

```

for i in [1 .. 40] do if cst[i] ne [ ]
then m:=m+1; end if; end for; m;
Orbits(N1141s);

N1142:=Stabiliser(N,[1,14,2]);
S:=[1,14,2];
SS:=SN;
SSS:=Setseq(SS);
for i in [1 .. # SS] do
for g in IN do if ts[1]*ts[14]*ts[2]
eq g*ts[Rep(SSS[i])[1]]*ts[Rep(SSS[i])[2]]*ts[Rep(SSS[i])[3]]
then print SSS[i];
end if; end for; end for;
N1142s:=N1142;
# N1142s;
T1142:=Transversal(N,N1142s);
# T1142;
for i := 1 to # T1142 do
ss := [1, 14, 2]T1142[i];
cst[prodim(1, ts, ss)] := ss;
end for;
m:=0;
for i in [1 .. 40] do if cst[i] ne [ ]
then m:=m+1; end if; end for; m;
Orbits(N1142s);

N121:=Stabiliser(N,[1,2,1]);
S:=[1,2,1];
SS:=SN;
SSS:=Setseq(SS);
for i in [1 .. # SS] do

```

```

for g in IN do if ts[1]*ts[2]*ts[1]
eq g*ts[Rep(SSS[i])[1]]*ts[Rep(SSS[i])[2]]*ts[Rep(SSS[i])[3]]
then print SSS[i];
end if; end for; end for;
N121s:=N121;
# N121s;
T121:=Transversal(N,N121s);
# T121;
for i := 1 to # T121 do
ss := [1, 2, 1]T121[i];
cst[prodim(1, ts, ss)] := ss;
end for;
m:=0;
for i in [1 .. 40] do if cst[i] ne [ ]
then m:=m+1; end if; end for; m;
Orbits(N121s);

N123:=Stabiliser(N,[1,2,3]);
S:=[1,2,3];
SS:=SN;
SSS:=Setseq(SS);
for i in [1 .. # SS] do
for g in IN do if ts[1]*ts[2]*ts[3]
eq g*ts[Rep(SSS[i])[1]]*ts[Rep(SSS[i])[2]]*ts[Rep(SSS[i])[3]]
then print SSS[i];
end if; end for; end for;
N123s:=N123;
# N123s;
T123:=Transversal(N,N123s);
# T123;
for i := 1 to # T123 do

```

```

ss := [1, 2, 3]T123[i];
cst[prodim(1, ts, ss)] := ss;
end for;
m:=0;
for i in [1 .. 40] do if cst[i] ne [ ]
then m:=m+1; end if; end for; m;
Orbits(N123s);

N124:=Stabiliser(N,[1,2,4]);
S:=[1,2,4];
SS:=SN;
SSS:=Setseq(SS);
for i in [1 .. # SS] do
for g in IN do if ts[1]*ts[2]*ts[4]
eq g*ts[Rep(SSS[i])[1]]*ts[Rep(SSS[i])[2]]*ts[Rep(SSS[i])[3]]
then print SSS[i];
end if; end for; end for;
N124s:=N124;
# N124s;
T124:=Transversal(N,N124s);
# T124;
for i := 1 to # T124 do
ss := [1, 2, 4]T124[i];
cst[prodim(1, ts, ss)] := ss;
end for;
m:=0;
for i in [1 .. 40] do if cst[i] ne [ ]
then m:=m+1; end if; end for; m;
Orbits(N124s);

N125:=Stabiliser(N,[1,2,5]);

```



```

S:=[1,2,5];
SS:=SN;
SSS:=Setseq(SS);
for i in [1 .. # SS] do
for g in IN do if ts[1]*ts[2]*ts[5]
eq g*ts[Rep(SSS[i])[1]]*ts[Rep(SSS[i])[2]]*ts[Rep(SSS[i])[3]]
then print SSS[i];
end if; end for; end for;
N125s:=N125;
# N125s;
T125:=Transversal(N,N125s);
# T125;
for i := 1 to # T125 do
ss := [1, 2, 5]T125[i];
cst[prodim(1, ts, ss)] := ss;
end for;
m:=0;
for i in [1 .. 40] do if cst[i] ne [ ]
then m:=m+1; end if; end for; m;
Orbits(N125s);

N126:=Stabiliser(N,[1,2,6]);
S:=[1,2,6];
SS:=SN;
SSS:=Setseq(SS);
for i in [1 .. #SS] do
for g in IN do if ts[1]*ts[2]*ts[6]
eq g*ts[Rep(SSS[i])[1]]*ts[Rep(SSS[i])[2]]*ts[Rep(SSS[i])[3]]
then print SSS[i];
end if; end for; end for;
N126s:=N126;

```

```

# N126s;
T126:=Transversal(N,N126s);
# T126;
for i := 1 to # T126 do
ss := [1, 2, 6]T126[i];
cst[prodim(1, ts, ss)] := ss;
end for;
m:=0;
for i in [1 .. 40] do if cst[i] ne [ ]
then m:=m+1; end if; end for; m;
Orbits(N126s);

N127:=Stabiliser(N,[1,2,7]);
S:=[1,2,7];
SS:=SN;
SSS:=Setseq(SS);
for i in [1 .. # SS] do
for g in IN do if ts[1]*ts[2]*ts[7]
eq g*ts[Rep(SSS[i])[1]]*ts[Rep(SSS[i])[2]]*ts[Rep(SSS[i])[3]]
then print SSS[i];
end if; end for; end for;
N127s:=N127;
# N127s;
T127:=Transversal(N,N127s);
# T127;
for i := 1 to # T127;
cst[prodim(1, ts, ss)] := ss;
end for;
m:=0;
for i in [1..40] do if cst[i] ne [ ]
then m:=m+1; end if; end for; m;

```

```

Orbits(N127s);

N128:=Stabiliser(N,[1,2,8]);
S:=[1,2,8];
SS:=SN;
SSS:=Setseq(SS);
for i in [1 .. # SS] do
for g in IN do if ts[1]*ts[2]*ts[8]
eq g*ts[Rep(SSS[i])[1]]*ts[Rep(SSS[i])[2]]*ts[Rep(SSS[i])[3]]
then print SSS[i];
end if; end for; end for;
N128s:=N128;
# N128s;
T128:=Transversal(N,N128s);
# T128;
for i := 1 to # T128 do
ss := [1, 2, 8]T128[i];
cst[prodim(1, ts, ss)] := ss;
end for;
m:=0;
for i in [1 .. 40] do if cst[i] ne [ ]
then m:=m+1; end if; end for; m;
Orbits(N128s);

N129:=Stabiliser(N,[1,2,9]);
S:=[1,2,9];
SS:=SN;
SSS:=Setseq(SS);
for i in [1 .. # SS] do
for g in IN do if ts[1]*ts[2]*ts[9]
eq g*ts[Rep(SSS[i])[1]]*ts[Rep(SSS[i])[2]]*ts[Rep(SSS[i])[3]]

```

```

then print SSS[i];
end if; end for; end for;
N129s:=N129;
# N129s;
T129:=Transversal(N,N129s);
# T129;
for i := 1 to # T129 do
ss := [1, 2, 9]T129[i];
cst[prodim(1, ts, ss)] := ss;
end for;
m:=0;
for i in [1..40] do if cst[i] ne [ ]
then m:=m+1; end if; end for; m;
Orbits(N129s);

N1210:=Stabiliser(N,[1,2,10]);
S:=[1,2,10];
SS:=SN;
SSS:=Setseq(SS);
for i in [1 .. # SS] do
for g in IN do if ts[1]*ts[2]*ts[10]
eq g*ts[Rep(SSS[i])[1]]*ts[Rep(SSS[i])[2]]*ts[Rep(SSS[i])[3]]
then print SSS[i];
end if; end for; end for;
N1210s:=N1210;
# N1210s;
T1210:=Transversal(N,N1210s);
# T1210;
for i := 1 to # T1210 do
ss := [1, 2, 10]T1210[i];
cst[prodim(1, ts, ss)] := ss;

```

```

end for;
m:=0;
for i in [ 1.. 40] do if cst[i] ne [ ]
then m:=m+1; end if; end for; m;
Orbits(N1210s);

N1211:=Stabiliser(N,[1,2,11]);
S:=[1,2,11];
SS:=SN;
SSS:=Setseq(SS);
for i in [1 .. # SS] do for g in IN do if ts[1]*ts[2]*ts[11]
eq g*ts[Rep(SSS[i])[1]]*ts[Rep(SSS[i])[2]]*ts[Rep(SSS[i])[3]]
then print SSS[i];
end if; end for; end for;
N1211s:=N1211;
# N1211s;
T1211:=Transversal(N,N1211s);
#T1211;
for i := 1 to # T1211 do
ss := [1, 2, 11]T1211[i];
cst[prodim(1, ts, ss)] := ss;
end for;
m:=0;
for i in [1 .. 40] do if cst[i] ne [ ]
then m:=m+1; end if; end for; m;
Orbits(N1211s);

N1212:=Stabiliser(N,[1,2,12]);
S:=[1,2,12];
SS:=SN;
SSS:=Setseq(SS);

```

```

for i in [1 .. # SS] do
for g in IN do if ts[1]*ts[2]*ts[12]
eq g*ts[Rep(SSS[i])[1]]*ts[Rep(SSS[i])[2]]*ts[Rep(SSS[i])[3]]
then print SSS[i];
end if; end for; end for;
N1212s:=N1212;
# N1212s;
T1212:=Transversal(N,N1212s);
# T1212;
for i := 1 to # T1212 do
ss := [1, 2, 12]T1212[i];
cst[prodim(1, ts, ss)] := ss;
end for;
m:=0;
for i in [1 .. 40] do if cst[i] ne [ ]
then m:=m+1; end if; end for; m;
Orbits(N1212s);

N1213:=Stabiliser(N,[1,2,13]);
S:=[1,2,13];
SS:=SN;
SSS:=Setseq(SS);
for i in [1 .. # SS] do
for g in IN do if ts[1]*ts[2]*ts[13]
eq g*ts[Rep(SSS[i])[1]]*ts[Rep(SSS[i])[2]]*ts[Rep(SSS[i])[3]]
then print SSS[i];
end if; end for; end for;
N1213s:=N1213;
# N1213s;
T1213:=Transversal(N,N1213s);
# T1213;

```

```

for i := 1 to # T1213 do
ss := [1, 2, 13]T1213[i];
cst[prodim(1, ts, ss)] := ss;
end for;
m:=0;
for i in [1 .. 40] do if cst[i] ne [ ]
then m:=m+1; end if; end for; m;
Orbits(N1213s);

N1214:=Stabiliser(N,[1,2,14]);
S:=[1,2,14];
SS:=SN;
SSS:=Setseq(SS);
for i in [1 .. # SS] do
for g in IN do if ts[1]*ts[2]*ts[14]
eq g*ts[Rep(SSS[i])[1]]*ts[Rep(SSS[i])[2]]*ts[Rep(SSS[i])[3]]
then print SSS[i];
end if; end for; end for;
N1214s:=N1214;
# N1214s;
T1214:=Transversal(N,N1214s);
# T1214;
for i := 1 to #T1214 do
ss := [1, 2, 14]T1214[i];
cst[prodim(1, ts, ss)] := ss;
end for;
m:=0;
for i in [1 .. 40] do if cst[i] ne [ ]
then m:=m+1; end if; end for; m;
Orbits(N1214s);

```

```

N1215:=Stabiliser(N,[1,2,15]);
S:=[1,2,15];
SS:=S^N;
SSS:=Setseq(SS);
for i in [1 .. #SS] do
for g in IN do if ts[1]*ts[2]*ts[15]
eq g*ts[Rep(SSS[i])[1]]*ts[Rep(SSS[i])[2]]*ts[Rep(SSS[i])[3]]
then print SSS[i];
end if; end for; end for;
N1215s:=N1215;
# N1215s;
T1215:=Transversal(N,N1215s);
# T1215;
for i := 1 to # T1215 do
ss := [1, 2, 15]^{T1215[i]};
cst[prodim(1, ts, ss)] := ss;
end for;
m:=0;
for i in [1 .. 40] do if cst[i] ne [ ]
then m:=m+1; end if; end for; m;
Orbits(N1215s);

N131:=Stabiliser(N,[1,3,1]);
S:=[1,3,1];
SS:=S^N;
SSS:=Setseq(SS);
for i in [1 .. # SS] do
for g in IN do if ts[1]*ts[3]*ts[1]
eq g*ts[Rep(SSS[i])[1]]*ts[Rep(SSS[i])[2]]*ts[Rep(SSS[i])[3]]
then print SSS[i];
end if; end for; end for;

```



```

N131s:=N131;
# N131s;
T131:=Transversal(N,N131s);
# T131;
for i := 1 to # T131 do
ss := [1, 3, 1]T131[i];
cst[prodim(1, ts, ss)] := ss;
end for;
m:=0;
for i in [1 .. 40] do if cst[i] ne [ ]
then m:=m+1; end if; end for; m;
Orbits(N131s);

N132:=Stabiliser(N,[1,3,2]);
S:=[1,3,2];
SS:=SN;
SSS:=Setseq(SS);
for i in [1 .. # SS] do
for g in IN do if ts[1]*ts[3]*ts[2]
eq g*ts[Rep(SSS[i])[1]]*ts[Rep(SSS[i])[2]]*ts[Rep(SSS[i])[3]]
then print SSS[i];
end if; end for; end for;
N132s:=N132;
# N132s;
T132:=Transversal(N,N132s);
# T132;
for i := 1 to # T132 do
ss := [1, 3, 2]T132[i];
cst[prodim(1, ts, ss)] := ss;
m:=0;
for i in [1 .. 40] do if cst[i] ne [ ]

```

```

then m:=m+1; end if; end for; m;
Orbits(N132s);

N134:=Stabiliser(N,[1,3,4]);
S:=[1,3,4];
SS:=SN;
SSS:=Setseq(SS);
for i in [1 .. # SS] do
for g in IN do if ts[1]*ts[3]*ts[4]
eq g*ts[Rep(SSS[i])[1]]*ts[Rep(SSS[i])[2]]*ts[Rep(SSS[i])[3]]
then print SSS[i];
end if; end for; end for;
N134s:=N134;
# N134s;
T134:=Transversal(N,N134s);
# T134;
for i := 1 to # T134 do
ss := [1, 3, 4]T134[i];
cst[prodim(1, ts, ss)] := ss;
end for;
m:=0;
for i in [ 1.. 40] do if cst[i] ne [ ]
then m:=m+1; end if; end for; m;
Orbits(N134s);

N135:=Stabiliser(N,[1,3,5]);
S:=[1,3,5];
SS:=SN;
SSS:=Setseq(SS);
for i in [1 .. # SS] do
for g in IN do if ts[1]*ts[3]*ts[5]

```

```

eq g*ts[Rep(SSS[i])[1]]*ts[Rep(SSS[i])[2]]*ts[Rep(SSS[i])[3]]
then print SSS[i];
end if; end for; end for;
N135s:=N135;
# N135s;
T135:=Transversal(N,N135s);
# T135;
for i := 1 to # T135 do
ss := [1, 3, 5]T135[i];
cst[prodim(1, ts, ss)] := ss;
end for;
m:=0;
for i in [1 .. 40] do if cst[i] ne [ ]
then m:=m+1; end if; end for; m;
Orbits(N135s);

N136:=Stabiliser(N,[1,3,6]);
S:=[1,3,6];
SS:=SN;
SSS:=Setseq(SS);
for i in [1 .. # SS] do
for g in IN do if ts[1]*ts[3]*ts[6]
eq g*ts[Rep(SSS[i])[1]]*ts[Rep(SSS[i])[2]]*ts[Rep(SSS[i])[3]]
then print SSS[i];
end if; end for; end for;
N136s:=N136;
# N136s;
T136:=Transversal(N,N136s);
# T136;
for i := 1 to # T136 do
ss := [1, 3, 6]T136[i];

```

```

cst[prodim(1, ts, ss)] := ss;
end for;
m:=0;
for i in [1 .. 40] do if cst[i] ne [ ]
then m:=m+1; end if; end for; m;
Orbits(N136s);

N137:=Stabiliser(N,[1,3,7]);
S:=[1,3,7];
SS:=SN;
SSS:=Setseq(SS);
for i in [1 .. # SS] do
for g in IN do if ts[1]*ts[3]*ts[7]
eq g*ts[Rep(SSS[i])[1]]*ts[Rep(SSS[i])[2]]*ts[Rep(SSS[i])[3]]
then print SSS[i];
end if; end for; end for;
T127:=Transversal(N,N127s);
# T127;
for i := 1 to # T127 do
ss := [1, 2, 7]T127[i];
cst[prodim(1, ts, ss)] := ss;
end for;
m:=0;
for i in [1 .. 40] do if cst[i] ne [ ]
then m:=m+1; end if; end for; m;
Orbits(N137s);

N138:=Stabiliser(N,[1,3,8]);
S:=[1,3,8];
SS:=SN;
SSS:=Setseq(SS);

```

```

for i in [1 .. # SS] do
for g in IN do if ts[1]*ts[3]*ts[8]
eq g*ts[Rep(SSS[i])[1]]*ts[Rep(SSS[i])[2]]*ts[Rep(SSS[i])[3]]
then print SSS[i];
end if; end for; end for;
N138s:=N138;
# N138s;
T138:=Transversal(N,N138s);
# T138;
for i := 1 to # T138 do
ss := [1, 3, 8]T138[i];
cst[prodim(1, ts, ss)] := ss;
end for;
m:=0;
for i in [1 .. 40] do if cst[i] ne [ ]
then m:=m+1; end if; end for; m;
Orbits(N138s);

N139:=Stabiliser(N,[1,3,9]);
S:=[1,3,9];
SS:=SN;
SSS:=Setseq(SS);
for i in [1 .. # SS] do
for g in IN do if ts[1]*ts[3]*ts[9]
eq g*ts[Rep(SSS[i])[1]]*ts[Rep(SSS[i])[2]]*ts[Rep(SSS[i])[3]]
then print SSS[i];
end if; end for; end for;
N139s:=N139;
# N139s;
T139:=Transversal(N,N139s);
# T139;

```

```

for i := 1 to # T139 do
ss := [1, 3, 9]T139[i];
cst[prodim(1, ts, ss)] := ss;
end for;
m:=0;
for i in [1 .. 40] do if cst[i] ne [ ]
then m:=m+1; end if; end for; m;
Orbits(N139s);

N1310:=Stabiliser(N,[1,3,10]);
S:=[1,3,10];
SS:=SN;
SSS:=Setseq(SS);
for i in [1 .. # SS] do
for g in IN do if ts[1]*ts[3]*ts[10]
eq g*ts[Rep(SSS[i])[1]]*ts[Rep(SSS[i])[2]]*ts[Rep(SSS[i])[3]]
then print SSS[i];
end if; end for; end for;
N1310s:=N1310;
# N1310s;
T1310:=Transversal(N,N1310s);
# T1310;
for i := 1 to # T1310 do
ss := [1, 3, 10]T1310[i];
cst[prodim(1, ts, ss)] := ss;
end for;
m:=0;
for i in [1 .. 40] do if cst[i] ne [ ]
then m:=m+1; end if; end for; m;
Orbits(N1310s);

```

```

N1311:=Stabiliser(N,[1,3,11]);
S:=[1,3,11];
SS:=SN;
SSS:=Setseq(SS);
for i in [1 .. # SS] do
for g in IN do if ts[1]*ts[3]*ts[11]
eq g*ts[Rep(SSS[i])[1]]*ts[Rep(SSS[i])[2]]*ts[Rep(SSS[i])[3]]
then print SSS[i];
end if; end for; end for;
N1311s:=N1311;
# N1311s;
T1311:=Transversal(N,N1311s);
# T1311;
for i := 1 to # T1311 do
ss := [1, 3, 11]T1311[i];
cst[prodim(1, ts, ss)] := ss;
end for;
m:=0;
for i in [1 .. 40] do if cst[i] ne [ ]
then m:=m+1; end if; end for; m;
Orbits(N1311s);

N1312:=Stabiliser(N,[1,3,12]);
S:=[1,3,12];
SS:=SN;
SSS:=Setseq(SS);
for i in [1 .. # SS] do
for g in IN do if ts[1]*ts[3]*ts[12]
eq g*ts[Rep(SSS[i])[1]]*ts[Rep(SSS[i])[2]]*ts[Rep(SSS[i])[3]]
then print SSS[i];
end if; end for; end for;

```

```

N1312s:=N1312;
# N1312s;
T1312:=Transversal(N,N1312s);
# T1312;
for i := 1 to # T1312 do
ss :=[1, 3, 12]T1312[i];
cst[prodim(1, ts, ss)] := ss;
end for;
m:=0;
for i in [1 .. 40] do if cst[i] ne [ ]
then m:=m+1; end if; end for; m;
Orbits(N1312s);

N1313:=Stabiliser(N,[1,3,13]);
S:=[1,3,13];
SS:=SN;
SSS:=Setseq(SS);
for i in [1 .. # SS] do
for g in IN do if ts[1]*ts[3]*ts[13]
eq g*ts[Rep(SSS[i])[1]]*ts[Rep(SSS[i])[2]]*ts[Rep(SSS[i])[3]]
then print SSS[i];
end if; end for; end for;
N1313s:=N1313;
# N1313s;
T1313:=Transversal(N,N1313s);
# T1313;
for i := 1 to # T1313 do
ss := [1, 3, 13][i];
cst[prodim(1, ts, ss)] := ss;
end for;
m:=0;

```



```

for i in [1 .. 40] do if cst[i] ne [ ]
then m:=m+1; end if; end for; m;
Orbits(N1313s);

N1314:=Stabiliser(N,[1,3,14]);
S:=[1,3,14];
SS:=SN;
SSS:=Setseq(SS);
for i in [1 .. # SS] do
for g in IN do if ts[1]*ts[3]*ts[14]
eq g*ts[Rep(SSS[i])[1]]*ts[Rep(SSS[i])[2]]*ts[Rep(SSS[i])[3]]
then print SSS[i];
end if; end for; end for;
N1314s:=N1314;
# N1314s;
T1314:=Transversal(N,N1314s);
# T1314;
for i := 1 to # T1314 do
ss := [1, 3, 14]T1314[i];
cst[prod(1, ts, ss)] := ss;
end for;
m:=0;
for i in [1 .. 40] do if cst[i] ne [ ]
then m:=m+1; end if; end for; m;
Orbits(N1314s);

N1315:=Stabiliser(N,[1,3,15]);
S:=[1,3,15];
SS:=SN;
SSS:=Setseq(SS);
for i in [1 .. # SS] do

```

```

for g in IN do if ts[1]*ts[3]*ts[15]
eq g*ts[Rep(SSS[i])[1]]*ts[Rep(SSS[i])[2]]*ts[Rep(SSS[i])[3]]
then print SSS[i];
end if; end for; end for;
N1315s:=N1315;
# N1315s;
T1315:=Transversal(N,N1315s);
# T1315;
for i := 1 to # T1315 do
ss := [1, 3, 15]T1315[i];
cst[prodim(1, ts, ss)] := ss;
end for;
m:=0;
for i in [1 .. 40] do if cst[i] ne [ ]
then m:=m+1; end if; end for; m;
Orbits(N1315s);

N114114:=Stabiliser(N,[1,14,1,14]);
S:=[1,14,1,14];
SS:=SN;
SSS:=Setseq(SS);
for i in [1 .. # SS] do
for g in IN do if ts[1]*ts[14]*ts[1]*ts[14]
eq g*ts[Rep(SSS[i])[1]]*ts[Rep(SSS[i])[2]]*ts[Rep(SSS[i])[3]]
*ts[Rep(SSS[i])[4]]
then print SSS[i];
end if; end for; end for;
N114114s:=N114114;
# N114114s;
T114114:=Transversal(N,N114114s);
# T114114;

```

```

for i := 1 to # T114114 do
ss := [1, 14, 1, 14]T114114[i];
cst[prodim(1, ts, ss)] := ss;
end for;
m:=0;
for i in [1 .. 40] do if cst[i] ne [ ]
then m:=m+1; end if; end for; m;
Orbits(N114114s);

N114115:=Stabiliser(N,[1,14,1,15]);
S:=[1,14,1,15];
SS:=SN;
SSS:=Setseq(SS);
for i in [1 .. # SS] do
for g in IN do
if ts[1]*ts[14]*ts[1]*ts[15]
eq g*ts[Rep(SSS[i])[1]]*ts[Rep(SSS[i])[2]]*ts[Rep(SSS[i])[3]]
*ts[Rep(SSS[i])[4]]
then print SSS[i];
end if; end for; end for;
N114115s:=N114115;
# N114115s;
T114115:=Transversal(N,N114115s);
# T114115;
for i := 1 to # T114115 do
ss := [1, 14, 1, 15]T114115[i];
cst[prodim(1, ts, ss)] := ss;
end for;
m:=0;
for i in [1 .. 40] do if cst[i] ne [ ]
then m:=m+1; end if; end for; m;

```

```

Orbits(N114115s);

N11412:=Stabiliser(N,[1,14,1,2]);
S:=[1,14,1,2];
SS:=SN;
SSS:=Setseq(SS);
for i in [1 .. #SS] do
for g in IN do if ts[1]*ts[14]*ts[1]*ts[2]
eq g*ts[Rep(SSS[i])[1]]*ts[Rep(SSS[i])[2]] *ts[Rep(SSS[i])[3]]*ts[Rep(SSS[i])[4]]
then print SSS[i];
end if; end for; end for;
N11412s:=N11412;
# N11412s;
T11412:=Transversal(N,N11412s);
# T11412;
for i := 1 to # T11412 do
ss := [1, 14, 1, 2]T11412[i];
cst[prodim(1, ts, ss)] := ss;
end for;
m:=0;
for i in [1 .. 40] do if cst[i] ne [ ]
then m:=m+1; end if; end for; m;
Orbits(N11412s);

N11413:=Stabiliser(N,[1,14,1,3]);
S:=[1,14,1,3];
SS:=SN;
SSS:=Setseq(SS);
for i in [1 .. # SS] do
for g in IN do if ts[1]*ts[14]*ts[1]*ts[3]
eq g*ts[Rep(SSS[i])[1]]*ts[Rep(SSS[i])[2]] *ts[Rep(SSS[i])[3]]*ts[Rep(SSS[i])[4]]

```

```

then print SSS[i];
end if; end for; end for;
N11413s:=N11413;
# N11413s;
T11413:=Transversal(N,N11413s);
# T11413;
for i := 1 to # T11413 do
ss := [1, 14, 1, 3]T11413[i];
cst[prodim(1, ts, ss)] := ss;
end for;
m:=0;
for i in [1 .. 40] do if cst[i] ne [ ]
then m:=m+1; end if; end for; m;
Orbits(N11413s);

N11414:=Stabiliser(N,[1,14,1,4]);
S:=[1,14,1,4];
SS:=SN;
SSS:=Setseq(SS);
for i in [1 .. # SS] do
for g in IN do if ts[1]*ts[14]*ts[1]*ts[4]
eq g*ts[Rep(SSS[i])[1]]*ts[Rep(SSS[i])[2]] *ts[Rep(SSS[i])[3]]*ts[Rep(SSS[i])[4]]
then print SSS[i];
end if; end for; end for;
N11414s:=N11414;
# N11414s;
T11414:=Transversal(N,N11414s);
# T11414;
for i := 1 to # T11414 do
ss := [1, 14, 1, 4]T11414[i];
cst[prodim(1, ts, ss)] := ss;

```

```
end for;  
m:=0;  
for i in [1 .. 40] do if cst[i] ne [ ]  
then m:=m+1; end if; end for; m;  
Orbits(N11414s);
```

Appendix D

Magma Work for $Sym(15)$

```

S:=Sym(15);
xx := S!(1, 2, 6, 3, 8, 14, 10, 7,
12, 11, 15, 13, 5, 9, 4);
yy := S!(2, 7, 8, 9)(3, 10, 5, 11)
(4, 12, 13, 6);
N:=sub< S|xx,yy >;
# N;
G< x,y,t > := Group< x,y,t|y4,y-1*x-2*y*x-1,t2,(t,y),(y-1*x-1*t)4,(x2*
t)4 >;
# G;
f,G1,k := CosetAction(G,sub< G|x,y >);
IN := sub< G1|f(x),f(y) >;
CompositionFactors(G1);
# DoubleCosets(G,sub< G|x,y >,sub< G|x,y >);
DoubleCosets(G,sub< G|x,y >, sub< G|x,y >);
NN|a,b| := Group< a,b|b4,b-1*a-2*b*a-1 >;
Sch:=SchreierSystem(NN,sub|NN—Id(NN)|);
ArrayP := [Id(N): i in [1 .. 60]];
for i in [2 .. 60] do
P:=[Id(N): l in [1..# Sch[i]]];

```

```

for j in [1..# Sch[i]] do
if Eltseq(Sch[i])[j] eq 1 then P[j]:=xx; end if;
if Eltseq(Sch[i])[j] eq -1 then P[j]:=xx-1; end if;
if Eltseq(Sch[i])[j] eq 2 then P[j]:=yy; end if;
if Eltseq(Sch[i])[j] eq -2 then P[j]:=yy-1; end if;
end for;
PP:=Id(N);
for k in [1..# P] do
PP:=PP*P[k]; end for;
ArrayP[i]:=PP;
end for;
for i in [1..60] do if ArrayP[i] eq
N!(2, 7, 8, 9)(3, 10, 5, 11)(4, 12, 13, 6)
then Sch[i];
end if; end for;
prodim := function(pt, Q, I)
v:=pt;
for i in I do
v:=v(Q[i];
end for;
return v;
end function;
ts := [ Id(G1): i in [1 .. 15] ]; ts[1]:=f(t); ts[2]:=f(tx); ts[3]:=f(tx3);
ts[4]:=f(tx14); ts[5]:=f(tx12);
ts[6]:=f(tx2);ts[7]:=f(tx7);
ts[8]:=f(tx4); ts[9]:=f(tx13);
ts[10]:=f(tx6); ts[11]:=f(tx9);
ts[12]:=f(tx8);ts[13]:=f(tx11);
ts[14]:=f(tx5); ts[15]:=f(tx10);
cst := [null : i in [1 .. Index(G,sub< G|x, y >))]
where null is [Integers( ) | ];

```



```

for i := 1 to 15 do
cst[prodim(1, ts, [i])]:= [i];
end for;
m:=0; for i in [1 .. 8] do if cst[i] ne [ ]
then m:=m+1; end if; end for; m;

N1:=Stabiliser(N,1);
S:=[1];
SS:=SN;
SSS:=Setseq(SS);
for i in [1 .. # SS] do
for g in IN do if ts[1]
eq g*ts[Rep(SS[i])[1]]
then print SSS[i];
end if; end for; end for;
N1s:=N1;
# N1s;
T1:=Transversal(N,N1s);
# T1;
for i := 1 to 15 do
cst[prodim(1, ts, [i])]:= [i];
end for;
m:=0; for i in [1 .. 8] do if cst[i] ne [ ]
then m:=m+1; end if; end for; m;
T1 := Transversal(N,N1s);
for i := 1 to # T1 do
SS := [1]T1[i];
cst[prodim(1, ts, SS)] := SS;
end for;
m:=0;
for i in [1 .. 8] do if cst[i] ne [ ] then m:=m+1;

```

```

end if; end for; m;
Orbits(N1s);

N12:=Stabiliser(N,[1,2]);
S:=[1,2];
SS:=SN;
SSS:=Setseq(SS);
for i in [1 .. # SS] do
for g in IN do if ts[1]*ts[2]
eq g*ts[Rep(SSS[i])[1]]*ts[Rep(SSS[i])[2]]
then print SSS[i];
end if; end for; end for;
N12s:=N12;
# N12s;
T12:=Transversal(N,N12s);
# T12;
for i := 1 to # T12 do
ss := [1, 2]T12[i];
cst[prodim(1, ts, ss)] := ss;
end for;
m:=0; for i in [1 .. 8] do if cst[i] ne [ ]
then m:=m+1; end if; end for; m;
Orbits(N12s);

N14:=Stabiliser(N,[1,4]);
S:=[1,4];
SS:=SN;
SSS:=Setseq(SS);
for i in [1 .. # SS] do
for g in IN do if ts[1]*ts[4]
eq g*ts[Rep(SSS[i])[1]]*ts[Rep(SSS[i])[2]]

```

```

then print SSS[i];
end if; end for; end for;
N14s:=N14;
# N14s;
T14:=Transversal(N,N14s);
# T14;
for i := 1 to # T14 do
ss := [1, 4]T14[i];
cst[prodim(1, ts, ss)] := ss;
end for;
m:=0; for i in [1 .. 8] do if cst[i] ne [ ]
then m:=m+1; end if; end for; m;

N121:=Stabiliser(N,[1,2,1]);
S:=[1,2,1];
SS:=SN;
SSS:=Setseq(SS);
for i in [1 .. # SS] do
for g in IN do if ts[1]*ts[2]*ts[1]
eq g*ts[Rep(SSS[i])[1]]*ts[Rep(SSS[i])[2]]
*ts[Rep(SSS[i])[3]]
then print SSS[i];
end if; end for; end for;
N121s:=N121;
# N121s;
T121:=Transversal(N,N121s);
# T121;
for i := 1 to # T121 do
ss := [1, 2, 1]T121[i];
cst[prodim(1, ts, ss)] := ss;
end for;

```

```

m:=0;
for i in [1 .. 8] do if cst[i] ne [ ]
then m:=m+1; end if; end for; m;
Orbits(N121s);

N124:=Stabiliser(N,[1,2,4]);
S:=[1,2,4];
SS:=SN;
SSS:=Setseq(SS);
for i in [1 .. # SS] do
for g in IN do if ts[1]*ts[2]*ts[4]
eq g*ts[Rep(SSS[i])[1]]*ts[Rep(SSS[i])[2]]
*ts[Rep(SSS[i])[3]]
then print SSS[i];
end if; end for; end for;
N124s:=N124;
# N124s;
T124:=Transversal(N,N124s);
# T124;
Orbits(N124s);

```

Appendix E

Magma Work for S_6

```

S:=Sym(5);
xx:=S!(1, 2, 4, 5, 3);
yy:=S!(2, 4, 3, 5);
N:=sub< S|xx, yy >;
# N;
G< x, y, t > := Group< x, y, t|y4, x-5, y-1 * x-2 * y * x-1, t2, (t, y), (y-1 * x-1 *
t)5, (x2 * t)6 >;
# G;
f,G1,k:=CosetAction(G,sub< G|x, y >);
IN:=sub< G1|f(x), f(y) >;
CompositionFactors(G1);
# DoubleCosets(G,sub< G|x, y >,sub< G|x, y >);
DoubleCosets(G,sub< G|x, y >, sub< G|x, y >);
NN< a, b > := Group< a, b|b4, a-5, b-1 * a-2 * b * a-1 >;
Sch:=SchreierSystem(NN,sub< NN|Id(NN) >);
ArrayP:=[Id(N): i in [1..20]];
for i in [2 .. 20] do
P:=[Id(N): l in [1..# Sch[i]]];
for j in [1..# Sch[i]] do
if Eltseq(Sch[i])[j] eq 1 then P[j]:=xx; end if;

```

```

if Eltseq(Sch[i])[j] eq -1 then P[j]:=xx-1; end if;
if Eltseq(Sch[i])[j] eq 2 then P[j]:=yy; end if;
if Eltseq(Sch[i])[j] eq -2 then P[j]:=yy-1; end if;
end for;
PP:=Id(N);
for k in [1..# P] do
PP:=PP*P[k]; end for;
ArrayP[i]:=PP;
end for;
for i in [1 .. 20] do if ArrayP[i]
eq N! (2, 4, 3, 5)
then Sch[i];
end if; end for;
prodim := function(pt, Q, I)
v:=pt;
for i in I do
v:=v(Q[i]);
end for;
return v;
end function;
ts := [ Id(G1): i in [1 .. 5] ];
ts[1]:=f(t); ts[2]:=f(tx); ts[3]:=f(t(x4)); ts[4]:=f(t(x2)); ts[5]:=f(t(x3));
cst:=[null : i in [1 .. Index(G,sub< G|x, y >)]]
where null is [Integers( ) | ];
for i := 1 to 5 do
cst[prodim(1, ts, [i])]:=i];
end for;
m:=0; for i in [1 .. 36] do if cst[i] ne [ ]
then m:=m+1; end if; end for; m;

N1:=Stabiliser(N,[1]);

```

```

S:=[1];
SS:=SN;
SSS:=Setseq(SS);
for i in [1 .. # SS] do
for g in IN do
if ts[1] eq g*ts[Rep(SSS[i])[1]]
then print SSS[i];
end if; end for; end for;
N1s:=N1;
# N1s;
T1:=Transversal(N,N1s);
# T1;
for i := 1 to # T1 do
ss := [1]T1[i];
cst[prodim(1, ts, ss)] := ss;
end for;
m:=0;for i in [1 .. 36] do if cst[i] ne [ ]
then m:=m+1; end if; end for; m;
Orbits(N1s);

N12:=Stabiliser(N,[1,2]);
S:=[1,2];
SS:=SN;
SSS:=Setseq(SS);
for i in [1 .. # SS] do
for g in IN do if ts[1]*ts[2]
eq g*ts[Rep(SSS[i])[1]]*ts[Rep(SSS[i])[2]]
then print SSS[i];
end if; end for; end for;
N12s:=N12;
# N12s;

```

```

T12:=Transversal(N,N12s);
# T12;
for i := 1 to # T12 do
ss := [1, 2]T12[i];
cst[prodim(1, ts, ss)] := ss;
end for;
m:=0;
for i in [1 .. 36] do if cst[i] ne [ ]
then m:=m+1; end if; end for; m;
Orbits(N12s);
N121:=Stabiliser(N,[1,2,1]);
S:=[1,2,1];
SS:=SN;
SSS:=Setseq(SS);
for i in [1 .. # SS] do
for g in IN do if ts[1]*ts[2]*ts[1]
eq g*ts[Rep(SSS[i])[1]]*ts[Rep(SSS[i])[2]]
*ts[Rep(SSS[i])[3]]
then print SSS[i];
end if; end for; end for;
N121s:=N121;
# N121s;
T121:=Transversal(N,N121s);
# T121;
for i := 1 to # T121 do
ss := [1, 2, 1]T121[i];
cst[prodim(1, ts, ss)] := ss;
end for;
m:=0;
for i in [1 .. 36] do if cst[i] ne [ ]
then m:=m+1; end if; end for; m;

```



```

Orbits(N121s);

N123:=Stabiliser(N,[1,2,3]);
S:=[1,2,3]; SS:=S^N;
SSS:=Setseq(SS);
for i in [1 .. # SS] do
for g in IN do if ts[1]*ts[2]*ts[3]
eq g*ts[Rep(SSS[i])[1]]*ts[Rep(SSS[i])[2]]
*ts[Rep(SSS[i])[3]]
then print SSS[i];
end if; end for; end for;
N123s:=N123;
# N123s;
T123:=Transversal(N,N123s);
# T123;
for i := 1 to # T123 do
ss := [1, 2, 3]^T123[i];
cst[prodim(1, ts, ss)] := ss;
end for;
m:=0;
for i in [1 .. 36] do if cst[i] ne [ ]
then m:=m+1; end if; end for; m;
Orbits(N123s);

N124:=Stabiliser(N,[1,2,4]);
S:=[1,2,4];
SS:=S^N;
SSS:=Setseq(SS);
for i in [1 .. # SS] do
for g in IN do if ts[1]*ts[2]*ts[4]
eq g*ts[Rep(SSS[i])[1]]*ts[Rep(SSS[i])[2]]

```

```

*ts[Rep(SSS[i])[3]]
then print SSS[i];
end if; end for; end for;
N124s:=N124;
# N124s;
T124:=Transversal(N,N124s);
# T124;
for i := 1 to # T124 do
ss := [1, 2, 4]T124[i];
cst[prodim(1, ts, ss)] := ss;
end for;
m:=0;
for i in [1 .. 36] do if cst[i] ne [ ]
then m:=m+1; end if; end for; m;
Orbits(N124s);

N125:=Stabiliser(N,[1,2,5]);
S:=[1,2,5];
SS:=SN;
SSS:=Setseq(SS);
for i in [1 .. # SS] do
for g in IN do if ts[1]*ts[2]*ts[5]
eq g*ts[Rep(SSS[i])[1]]*ts[Rep(SSS[i])[2]]
*ts[Rep(SSS[i])[3]]
then print SSS[i];
end if; end for; end for;
N125s:=N125;
# N125s;
T125:=Transversal(N,N125s);
# T125;
T125:=Transversal(N,N125s);

```

```

for i := 1 to # T125 do
ss := [1, 2, 5]T125[i];
cst[prodim(1, ts, ss)] := ss;
end for;
m:=0;
for i in [1 .. 36] do if cst[i] ne [ ]
then m:=m+1; end if; end for; m;
Orbits(N125s);

N1215:=Stabiliser(N,[1,2,1,5]);
S:=[1,2,1,5];
SS:=SN;
SSS:=Setseq(SS);
for i in [1 .. # SS] do
for g in IN do if ts[1]*ts[2]*ts[1]*ts[5]
eq g*ts[Rep(SSS[i])[1]]*ts[Rep(SSS[i])[2]]
*ts[Rep(SSS[i])[3]]*ts[Rep(SSS[i])[4]]
then print SSS[i];
end if; end for; end for;
N1215s:=N1215;
# N1215s;
T1215:=Transversal(N,N1215s);
# T1215;
for i := 1 to # T1215 do ss := [1, 2, 1, 5]T1215[i];
cst[prodim(1, ts, ss)] := ss;
end for;
m:=0;
for i in [1 .. 36] do if cst[i] ne [ ]
then m:=m+1; end if; end for; m;
Orbits(N1215s);

```

```

N1245:=Stabiliser(N,[1,2,4,5]);
S:=[1,2,4,5];
SS:=SN;
SSS:=Setseq(SS);
for i in [1 .. # SS] do
for g in IN do if ts[1]*ts[2]*ts[4]*ts[5]
eq g*ts[Rep(SSS[i])[1]]*ts[Rep(SSS[i])[2]]
*ts[Rep(SSS[i])[3]]*ts[Rep(SSS[i])[4]]
then print SSS[i];
end if; end for; end for;
N1245s:=N1245;
# N1245s;
T1245:=Transversal(N,N1245s);
# T1245;
for i := 1 to # T1245 do ss := [1, 2, 4, 5]T1245[i];
cst[prodim(1, ts, ss)] := ss;
end for;
m:=0;
for i in [1 .. 36] do if cst[i] ne [ ]
then m:=m+1; end if; end for; m;
Orbits(N1245s);

```

Bibliography

- [Cur07] R.T. Curtis *Symmetric Generation of Groups: With Applications to many of the Sporadic Simple Finite Groups.*, Cambridge University Press, 2007.
- [DM96] John D. Dixon and B. Mortimer. *Permutation Groups.*, Springer, 1996.
- [Isa76] M. Isaacs *Character Theory of Finite Groups*, Dover Publication, 1976.
- [Rot95] Joseph J Rotman. *An Introduction to the Theory of Groups.*, Springer, 1995.
- [Tra13] Jesse Graham Train. *Enumeration and symmetric presentations of groups, with music theory applications.*, Master's thesis, CSUSB, June 2013.
- [Why06] Sophie Whyte. *Symmetric Generation: Permutation Images and Irreducible Monomial Representations.*, PhD thesis, University of Birmingham, September 2006.
- [WWI] R Wilson, P Walsh, and Suleiman I. *ATLAS of Finite Group Representations - V3*, <http://brauer.maths.qmul.ac.uk/Atlas/v3/>.
- [Wik] Wikipedia. *Schur multiplier.*, https://en.wikipedia.org/wiki/Schur_multiplier.
- [CB] J. Cannon and W. Bosma. *Handbook of magma functions.*, <https://www.google.com>.